



VERTICAL VENGEANCE™ COASTER



WARNING:

CHOKING HAZARD - Small parts.
Not for children under 3 years.



AVERTISSEMENT:

DANGER D'ÉTOUFFEMENT - Pièces de petite taille.
Ne pas donner aux enfants de moins de 3 ans.



10+

1376 pcs/pzs/pzas

50080/22808

VERTICAL VENGEANCE™ COASTER

Build this real working roller coaster that towers over 5 feet (1.6m) tall, complete with 33 feet (10.06m) of spine twisting track. A motorized chain lift carries the cars to the top. Then, watch the cars race to the bottom with real coaster sounds and screams!

WHAT'S INSIDE?

IMPORTANT STUFF FOR PARENTS & KIDS	3
BATTERY INFORMATION	3
K'NEX BUILDING BASICS	4
PARTS COUNT	5
VERTICAL VENGEANCE (ADVANCED BUILD)	6
TROUBLESHOOTING	73
ALTERNATE COASTER (INTERMEDIATE BUILD)	76
FRENCH	114
SPANISH	115
GERMAN	116
DUTCH	117
ITALIAN	118
PORTUGUESE	119



IMPORTANT STUFF FOR PARENTS & KIDS

Keep these instructions in a handy location. They contain important safety information.

Read all warnings and instructions before you start to build and operate the model.

WARNING: CHOKING HAZARD - Small parts. Not for Children under 3 years.

WARNING: This is a Class 1 LED Product.

CAUTION: Keep hands, face, hair and clothing away from all moving parts.

CAUTION: Hair entanglement may result if hair comes in contact with moving parts of motor. Adult supervision is required.

CAUTION: Do not use Sound Module close to ear! Misuse may cause damage to hearing.

Helpful Tips:

- Adult building help is recommended.
- Share the K'NEX experience with your child and make building with K'NEX a family fun adventure.
- Don't rush! Take your time to enjoy the building process.
- Try to face your model in the same direction as shown in the instructions while you build.
- Product and colors may vary.
- For additional building help go to the K'NEX web site: www.knex.com/tips

BATTERY INFORMATION

CAUTION:

- Be sure to insert the batteries correctly and always follow the toy and battery manufacturers' instructions.
- Do not mix old and new batteries or alkaline, standard (carbon-zinc) or rechargeable (nickel-cadmium) batteries. Only batteries of the same or equivalent type recommended should be used.
- Always remove weak or dead batteries from the product; do not short-circuit supply terminals.
- Insert batteries with correct polarity (+/-) as shown.

Important Tips:

- Alkaline batteries are recommended.
- Rechargeable batteries are not recommended.
- Remove rechargeable batteries from toy before charging; they must be charged only under adult supervision.
- Non-rechargeable batteries must not be recharged.
- Keep components free of dust; do not immerse or use in water.
- Do not dispose of batteries in a fire; they could leak or explode and cause injury.
- Remove all batteries if the toy will not be used for a long period of time.
- Do not put Rods smaller than 2 inches in any openings of the motor; they will damage the motor, and cannot be removed.

How to Insert and Reomove Batteries:

- **MOTOR:** Use a small Phillips head screwdriver to loosen the screw. Insert 2 fresh AA batteries (LR6) into the compartment with the correct polarity (+/-) as shown.

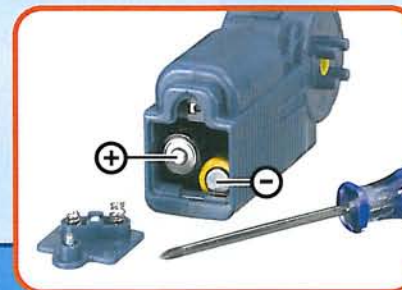

Sound Module:

- Install all batteries in the Sound Module before you start building.
- Sound Module requires 3 AAA (or LR03) batteries. Alkaline batteries are recommended.
- Use a small Phillips head screwdriver to open the Sound Module. Insert 3 fresh AAA batteries (LR03), inside the compartment with correct polarity (+/-).



- Sound Module may not work properly in direct sunlight.
- Sound Module's sensor detects the Car's motion. Make sure the sensor is aligned with and facing the Reflective Sticker. Push the gray button on the side to activate sound. The Sound Module will shut off after 10 minutes. Push the button again to reactivate the sound.

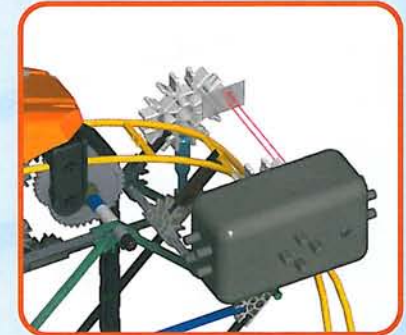



BUILDING BASICS



"Hi! I'm your K'NEX Building Buddy. When you see me in the instructions, you'll want to pay close attention to the details being pointed out."

Ready, Set, Build

To begin your model, find the **1** and follow the numbers. Each piece has its own shape and color. Just look at the pictures, find the pieces in your set that match and then connect them together. Try to face your model in the same direction as the instructions while you build.

Moving On

Faded colors show you that this section is already built. You'll want to connect the new section to the place where the arrows are pointing. The new pieces you add and the place where they connect will be in full color.

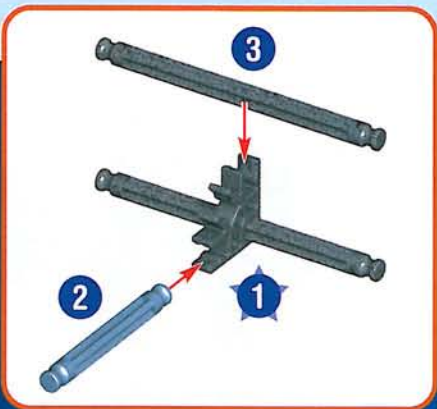

Connectors

There are blue and silver Connectors with special long slots. They slide together as you see in the pictures. Push these parts together until you hear a "click."

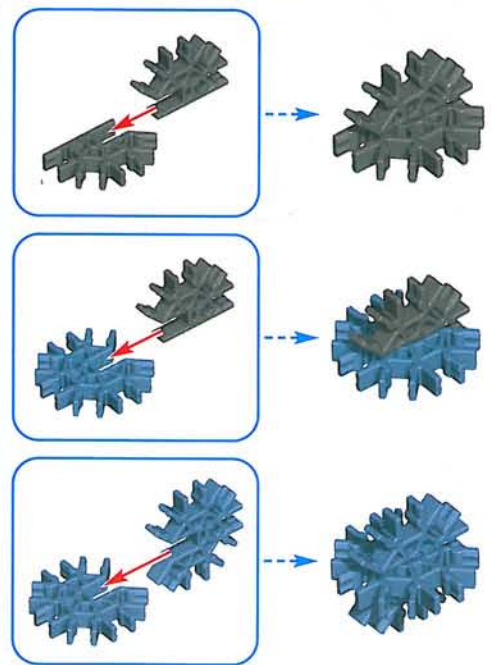

Spacers

There are 3 different kinds of Spacers in the set. Be sure to use the right color and count them carefully.

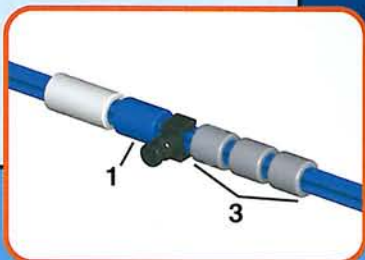

Chain Links

Important: attach all the Chain Links in the same direction.

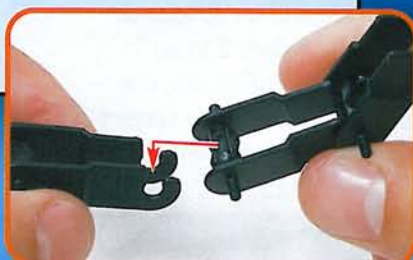

Gears

To engage the Gear, push the tan Lock into the holes on the Gear. Note the position of the Gear and the direction of the teeth. Make sure the teeth on both of the Gears mesh together.

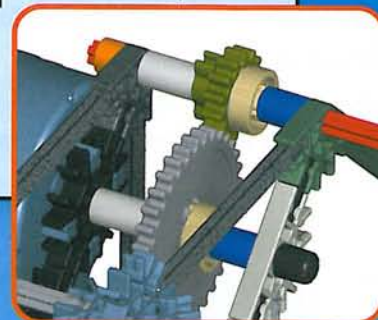



Parts Count

Before you start building, be sure to compare the parts in your set with the parts listed here.

If anything is missing, check out the back cover of this instructions booklet for how to contact us.

We're here to help!

FCC Statements:

This device complies with Part 15 of the FCC Rules. Operation is subject to the following two conditions:

1. This device may not cause harmful interference and
2. This device must accept any interference received, including interference that may cause undesired operation.

This model is tested to comply with FCC standards - FOR HOME OR OFFICE USE.

This equipment has been tested and found to comply with the limits for a Class B digital device, pursuant to part 15 of the FCC Rules. These limits are designed to provide reasonable protection against harmful interference in a residential installation. This equipment generates, uses and can radiate radio frequency energy, and, if not installed and used in accordance with the instructions, may cause harmful interference to radio communications. However, there is no guarantee that interference will not occur in a particular installation. If this equipment does cause harmful interference to radio or television reception, which can be determined by turning the equipment off and on, the user is

encouraged to try to correct the interference by one or more of the following measures: (1) Reorient or relocate the receiving antenna. (2) Increase the separation between the equipment and receiver. (3) Consult the dealer or an experienced radio/TV technician. This Class B digital apparatus complies with Canadian ICES-003.

Our Warranty (US and Canada)

K'NEX Industries warrants the VERTICAL VENGEANCE set to be free of manufacturing defects in material and workmanship for a period of 90 days from the date of purchase. If, within the period of warranty, any part proves to have such defect, it will be replaced or repaired at our option at no charge.

K'NEX will not be responsible for damage and/or abuse to your VERTICAL VENGEANCE set, and such will not be covered by this warranty. Also, K'NEX will not be responsible for damage caused by defective or old batteries. Old or damaged batteries can leak and corrode metals.

K'NEX's sole and exclusive liability for defects in materials and workmanship shall be limited to repair or replacement by our Consumer Services Department, and K'NEX shall not be liable of incidental, consequential, contingent damages, except in those states that do not allow this exclusion or limitation. This warranty gives you specific legal rights. You may have other rights which vary from state to state.

VERTICAL VENGEANCE: (ADVANCED BUILD)

TOWER 1

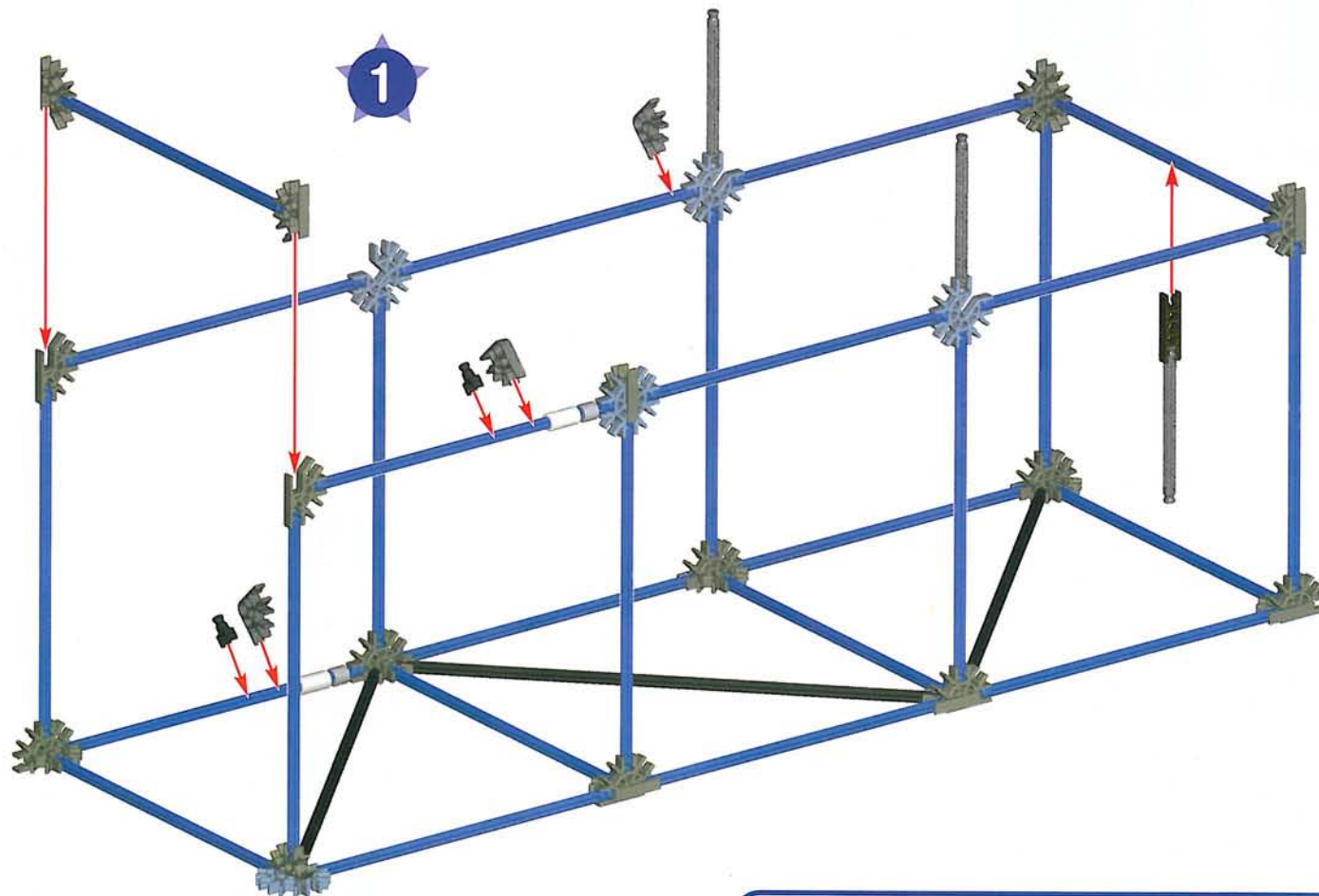
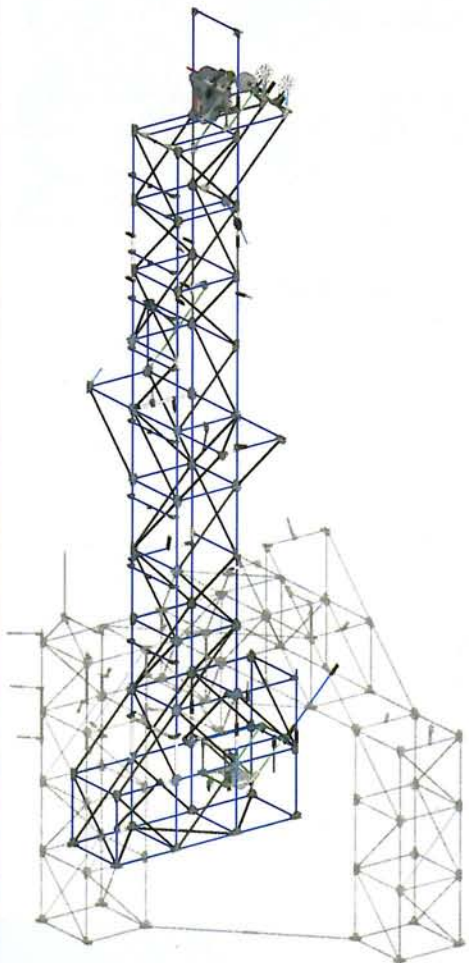

- (ENG) Be sure to position the blue and silver Connectors exactly as shown.
- (F) Veille à placer les connecteurs bleu et argent exactement comme l'indique le schéma.
- (E) Asegúrate de que colocas los conectores azules y plateados exactamente como se muestran.
- (D) Befestige die blauen und silbernen Verbindungsstücke genau so wie auf der Abbildung gezeigt.
- (NL) Verzeker je ervan om de blauwe en zilveren koppelstukken precies aan te brengen zoals afgebeeld.
- (I) Posiziona i connettori blu e argento esattamente come illustrato.
- (P) Certifcate de que posicionas os Conectores azul e prata exactamente conforme indicado.

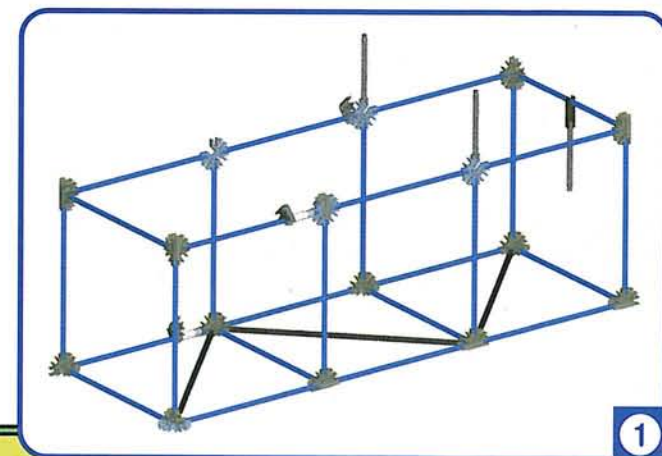

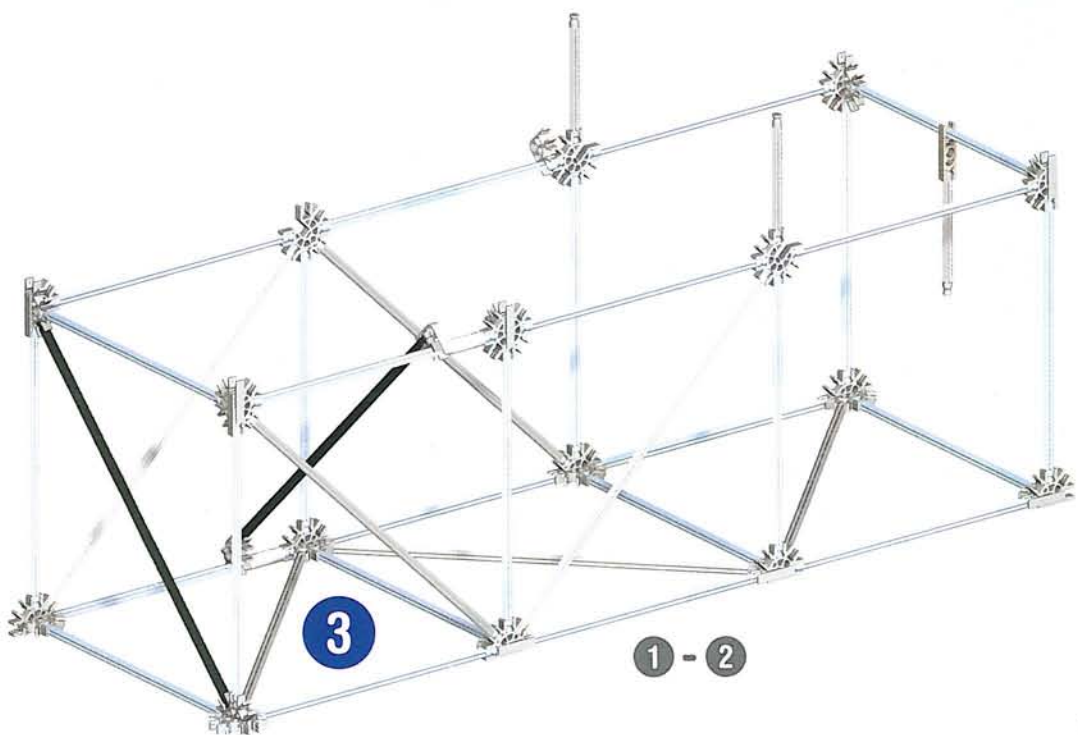
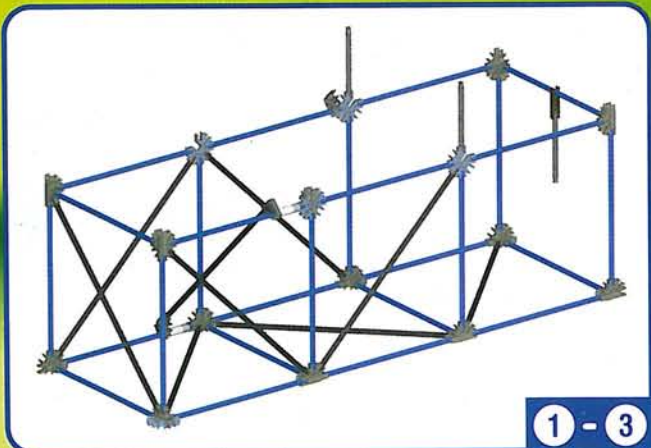
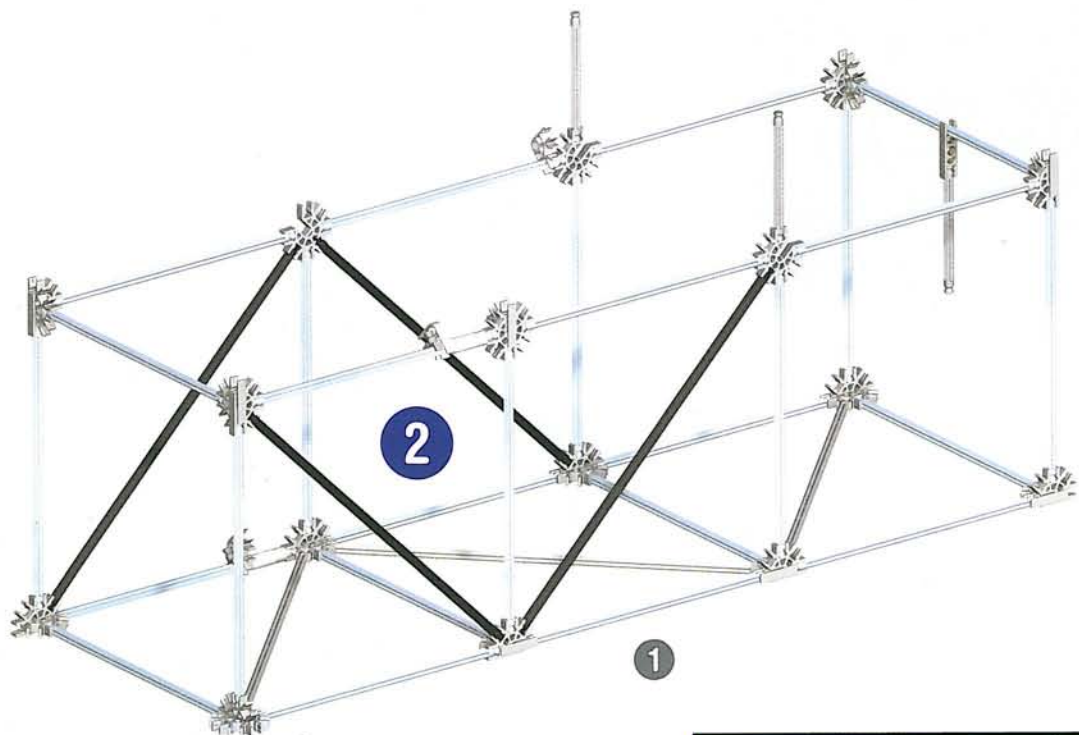

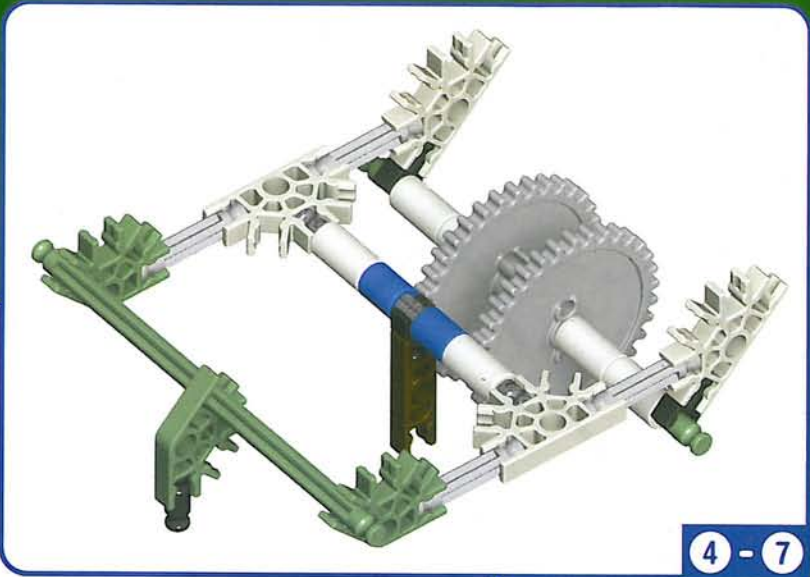
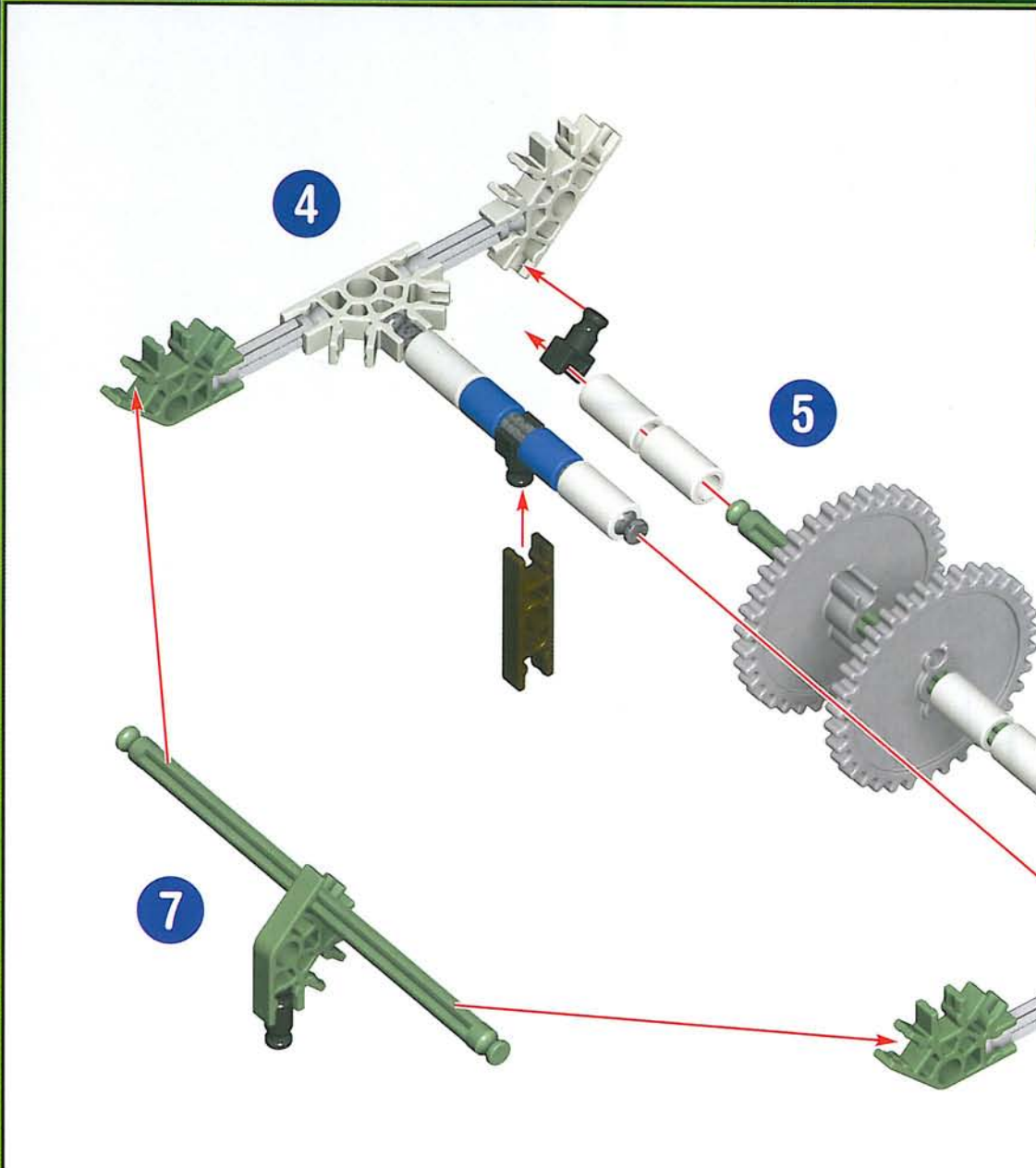

4-7

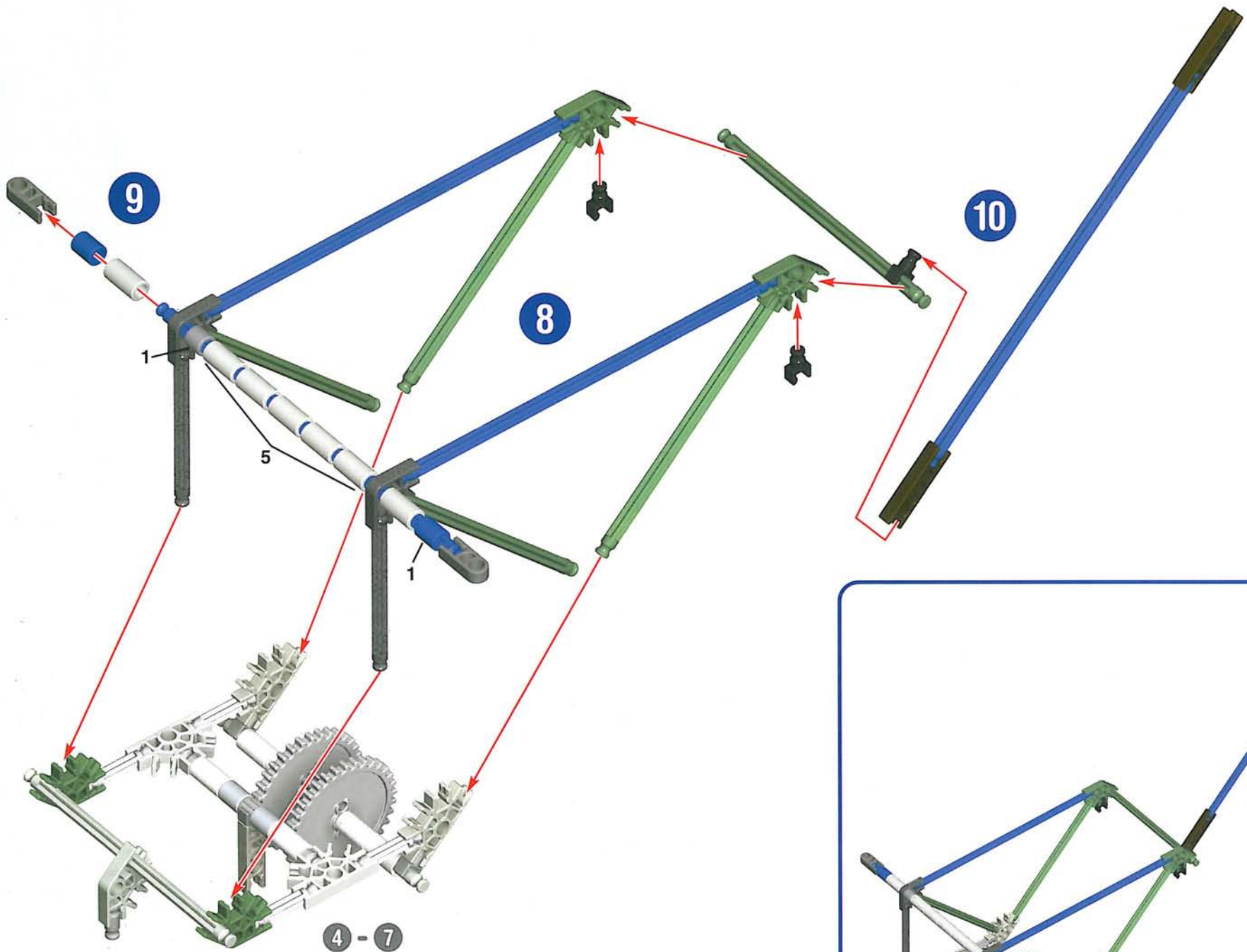

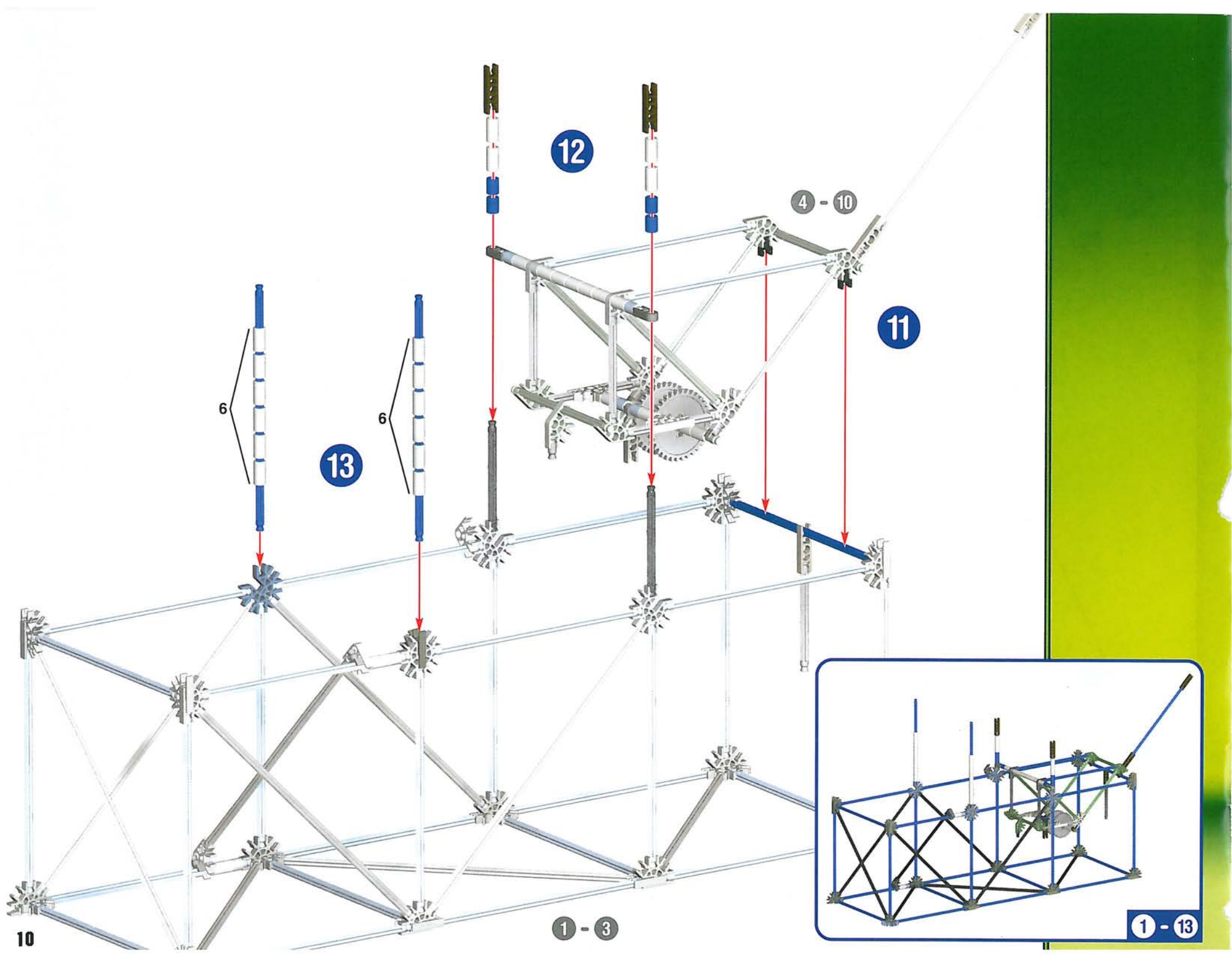

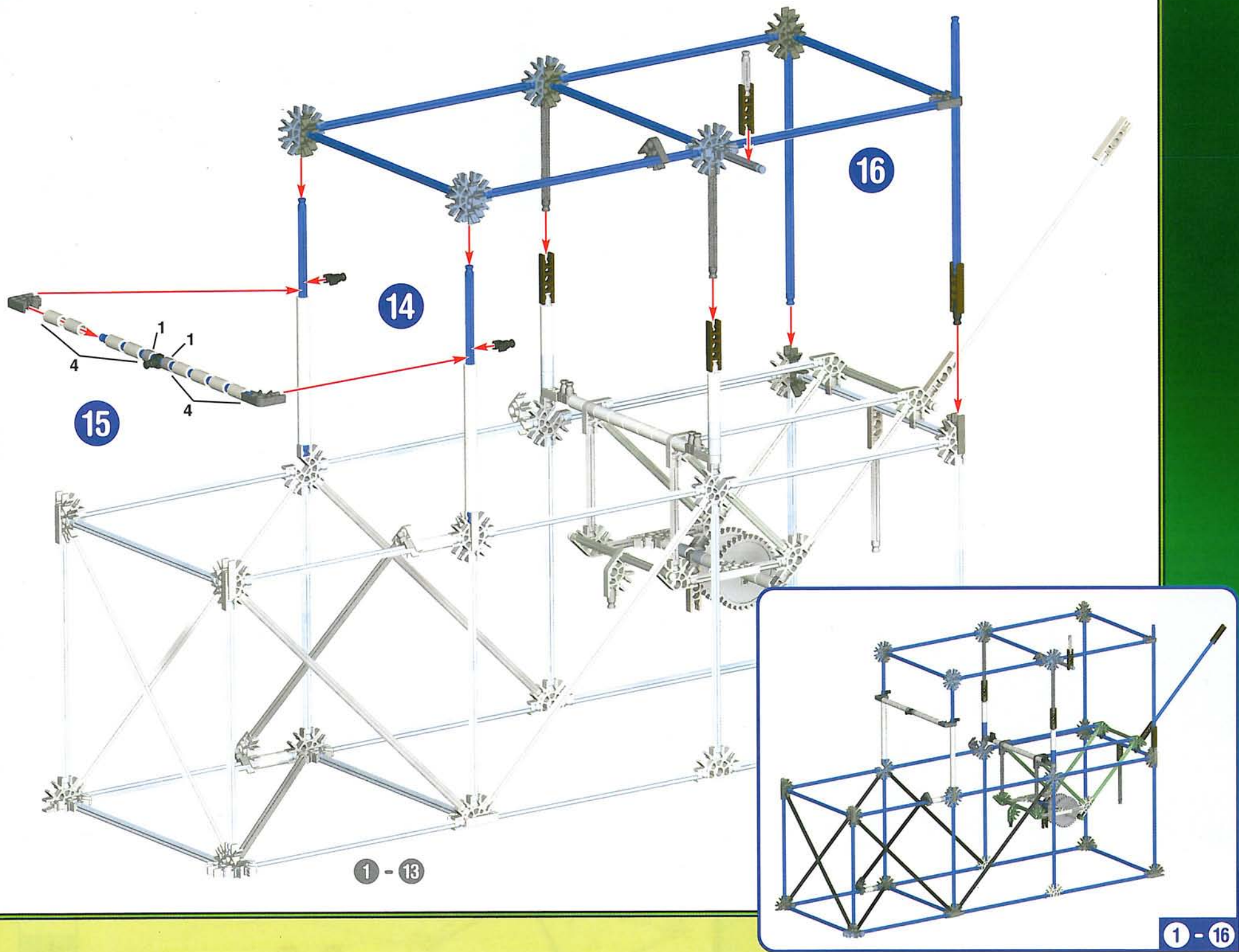

1 - 13

16

14

15

1 - 16

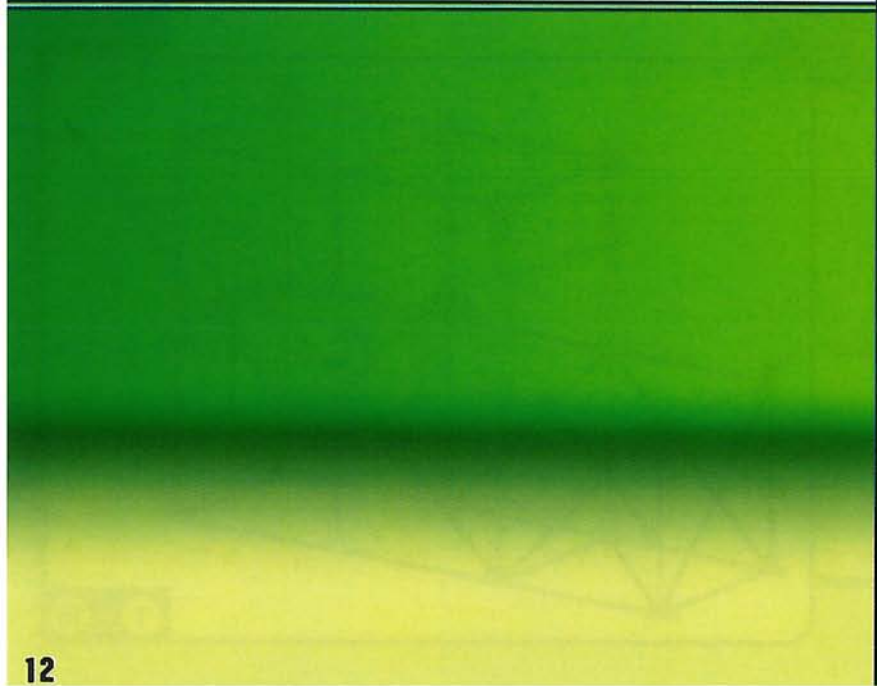
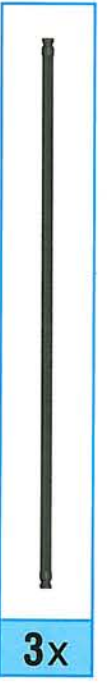
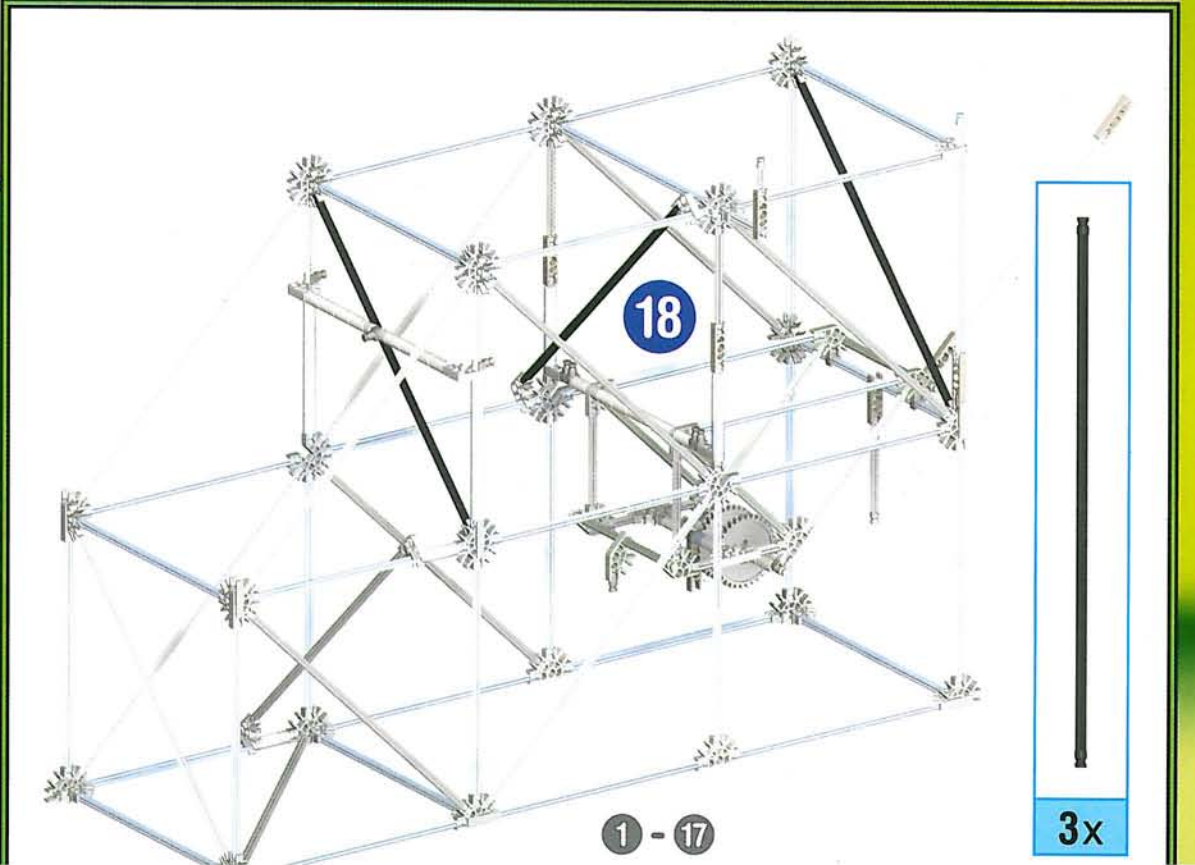
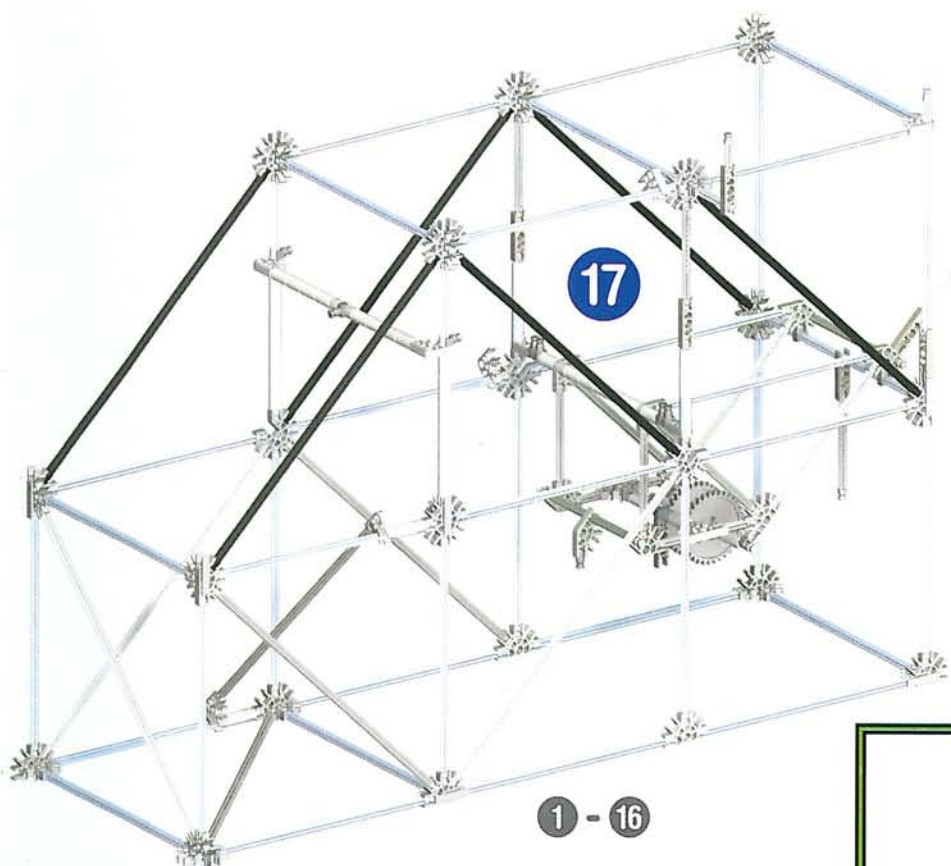

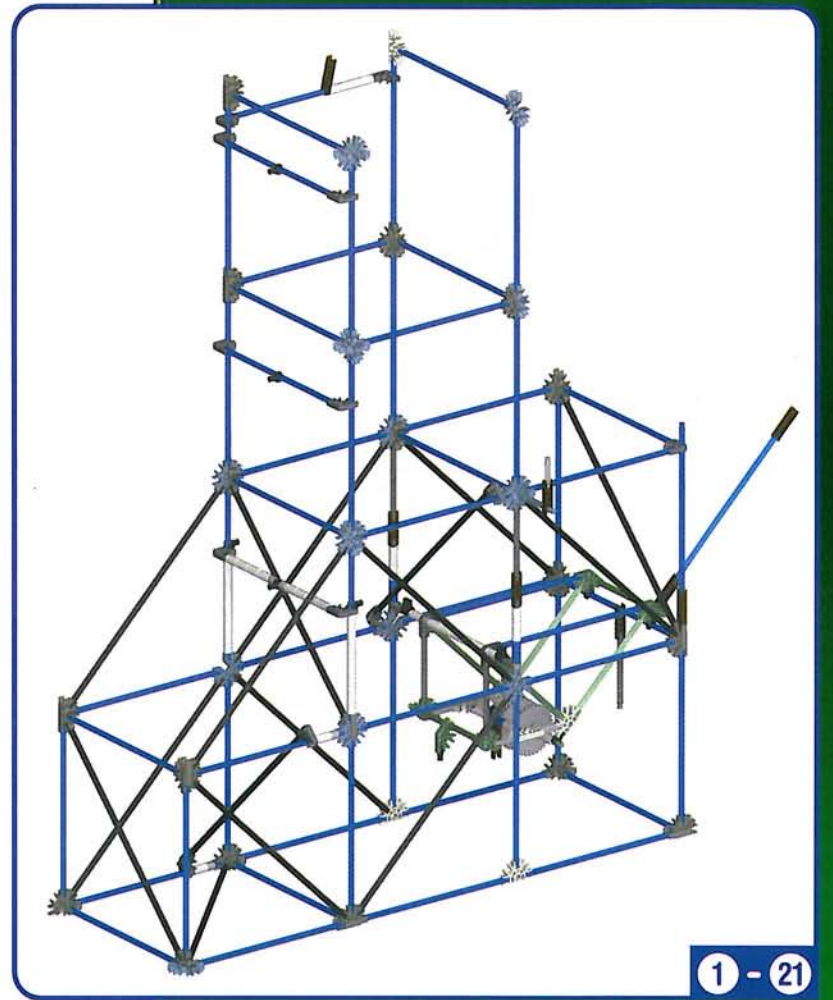
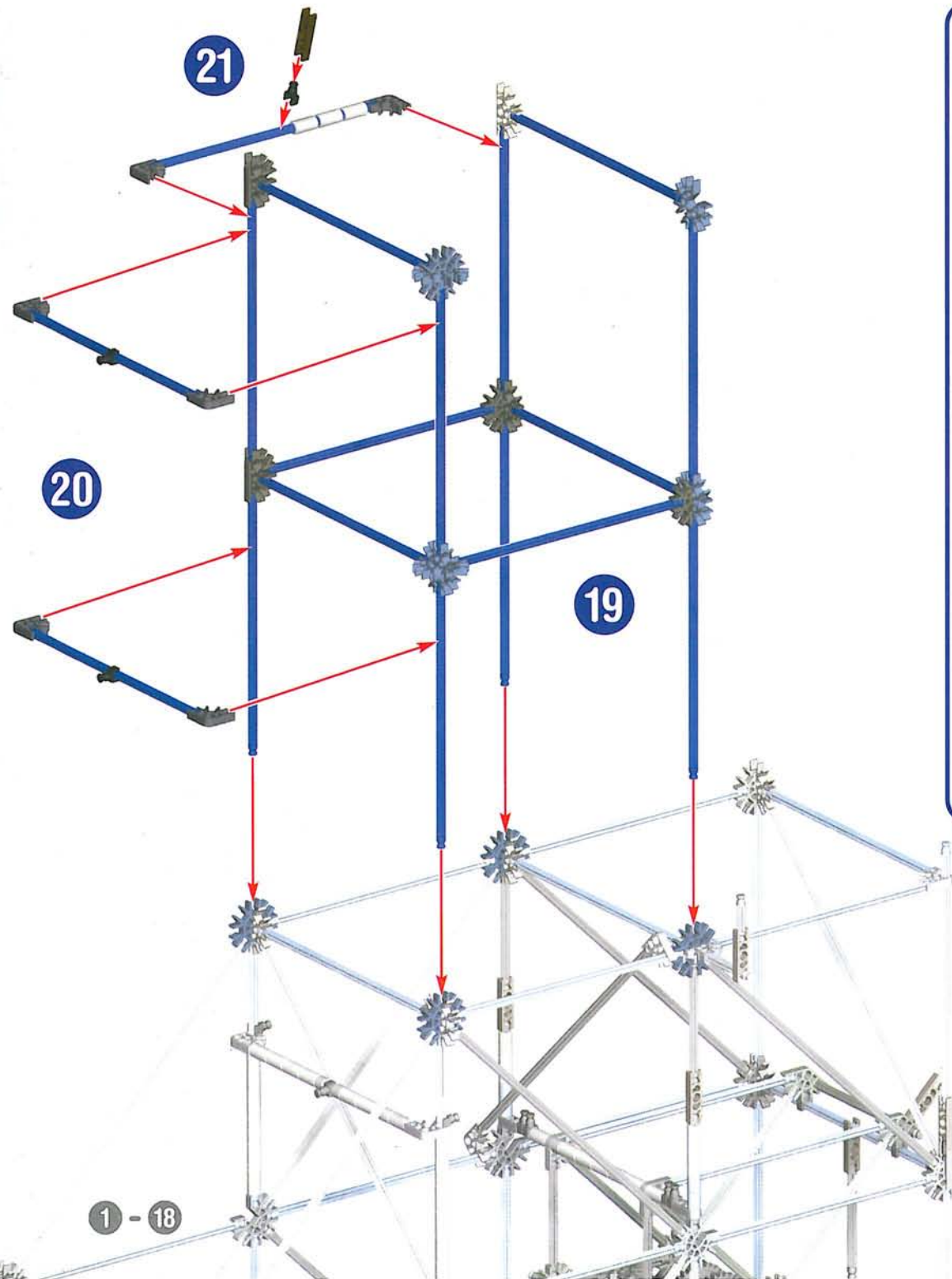

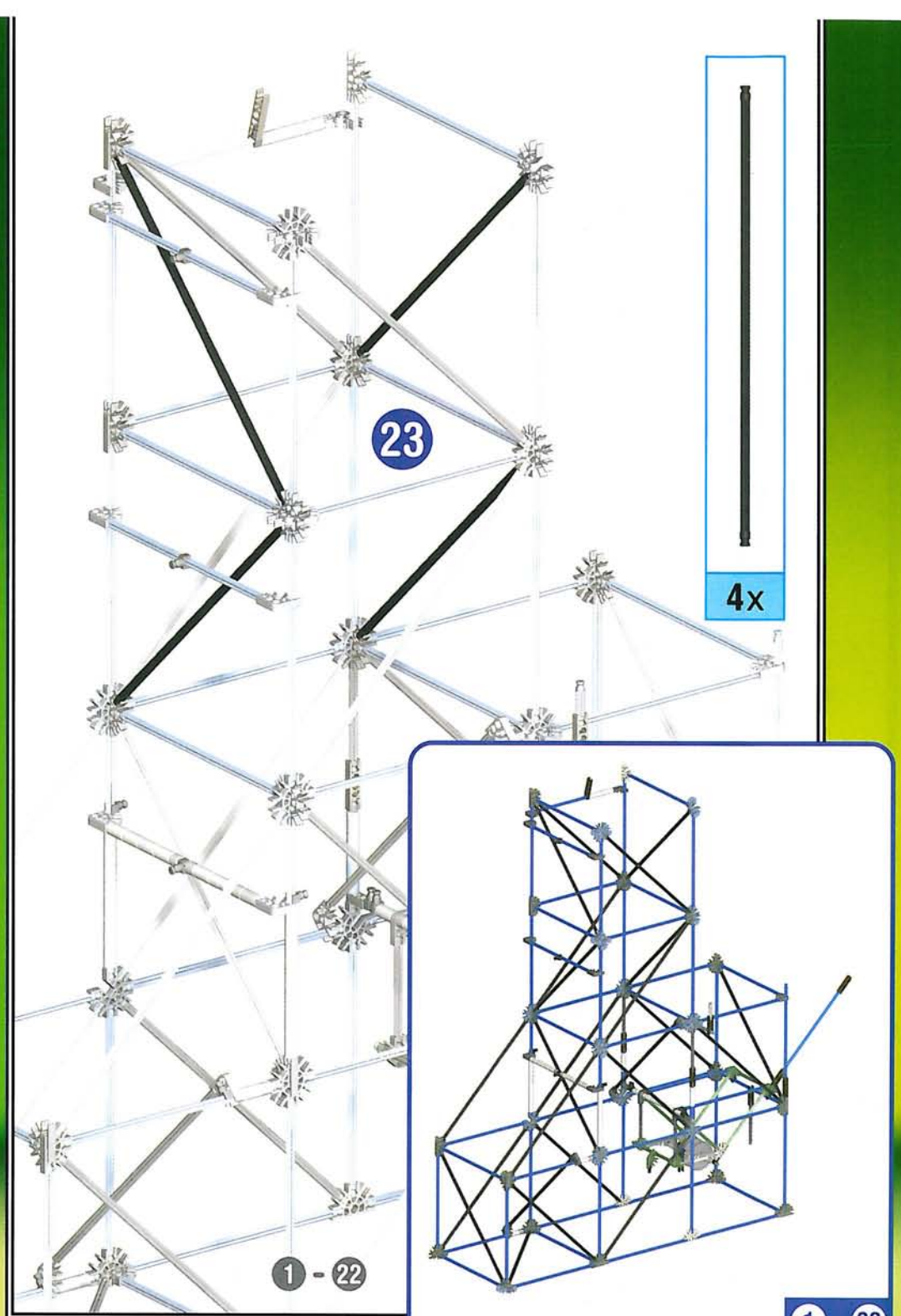
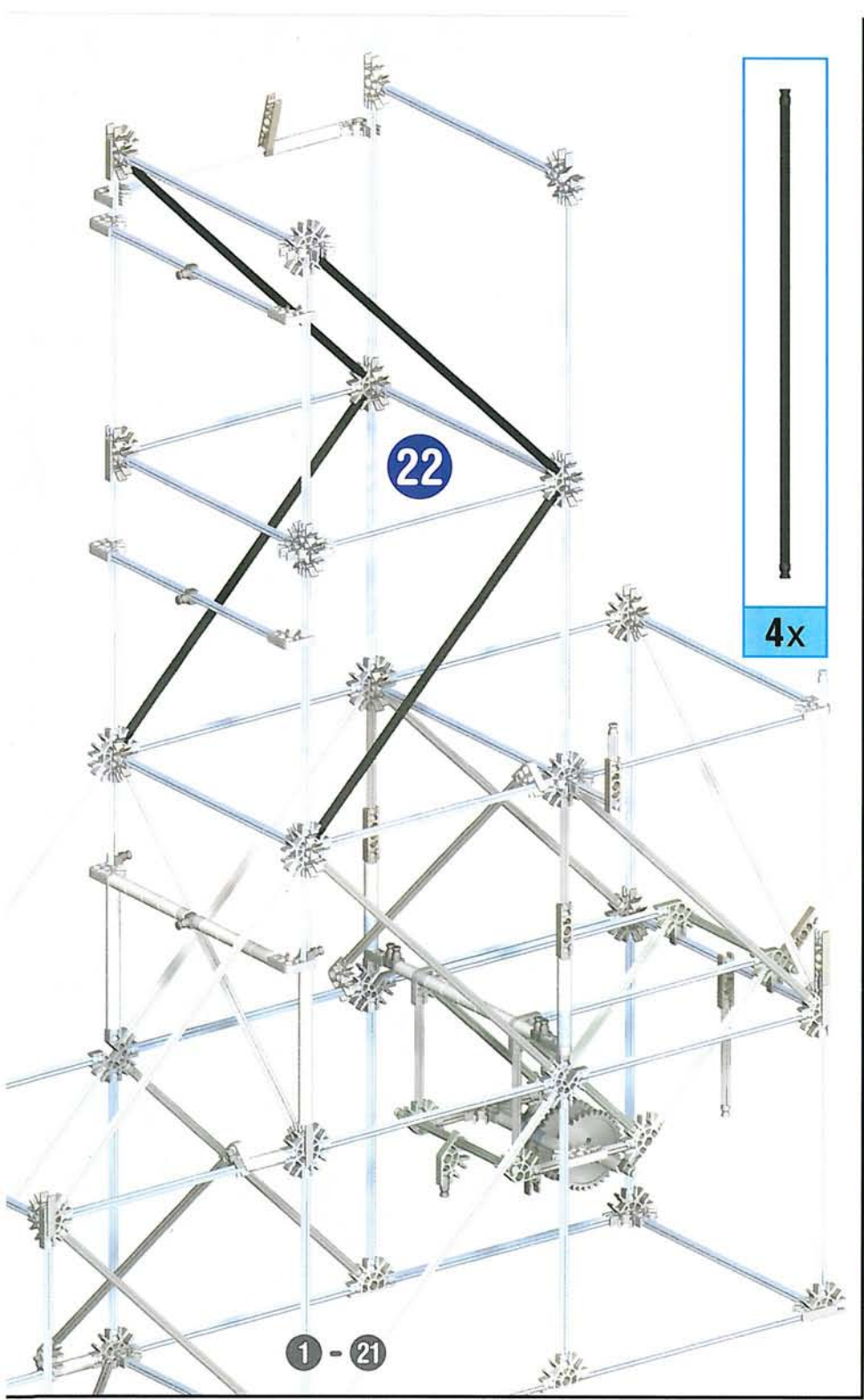

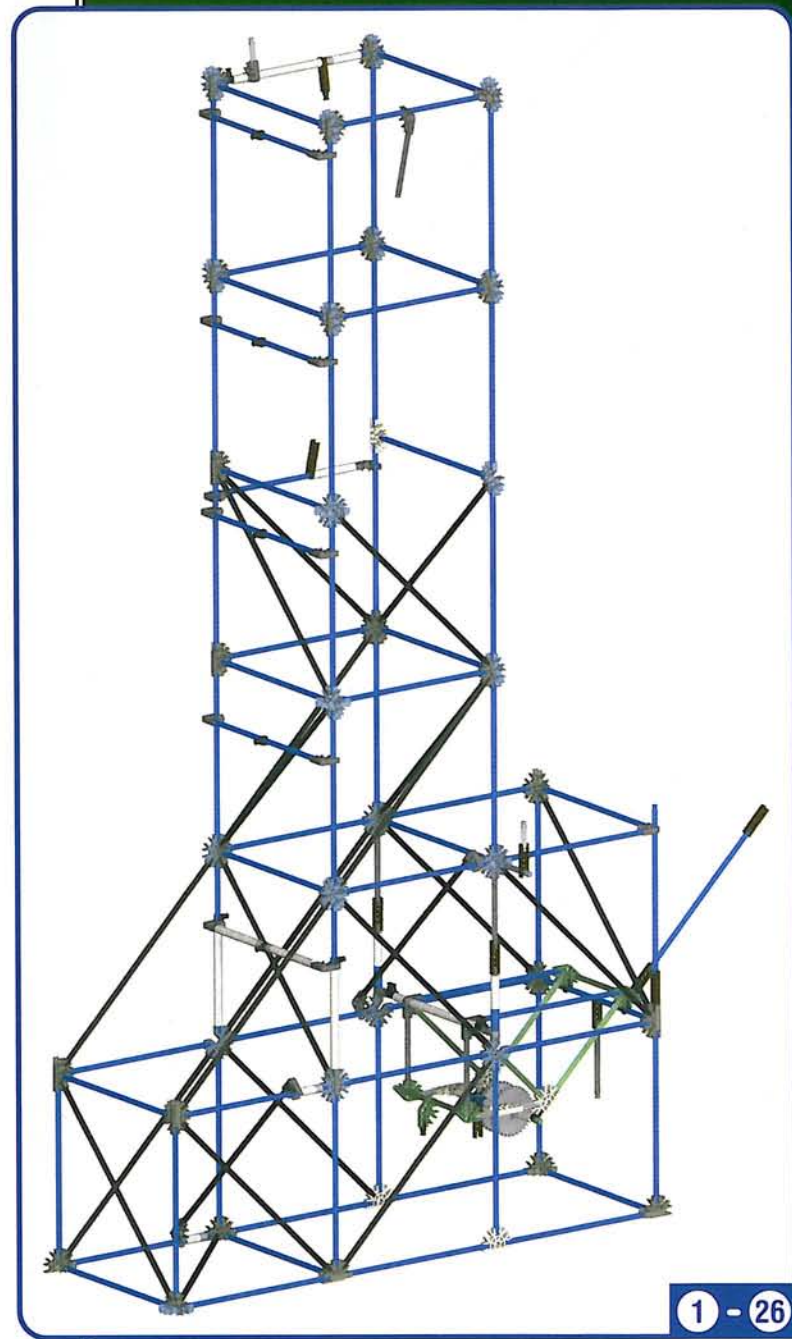
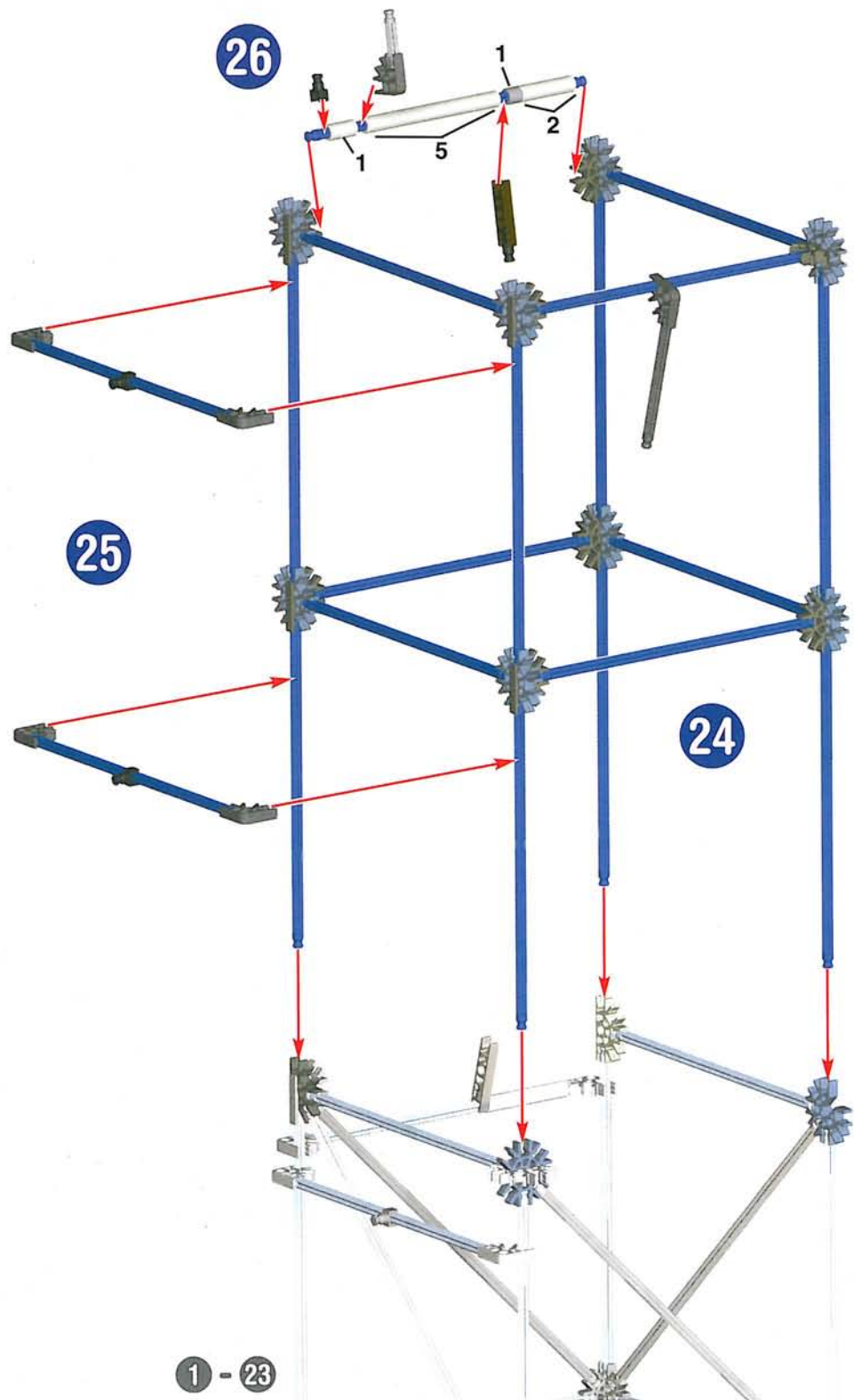

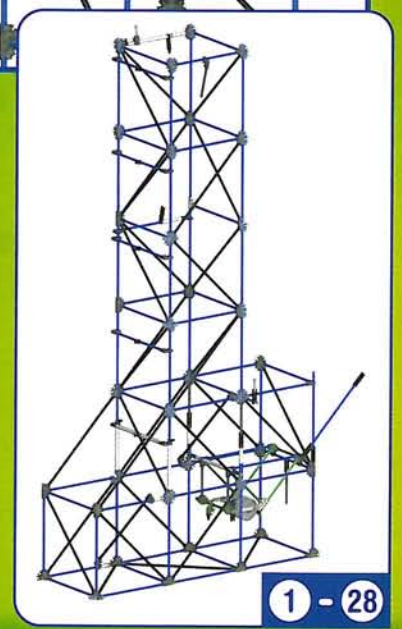
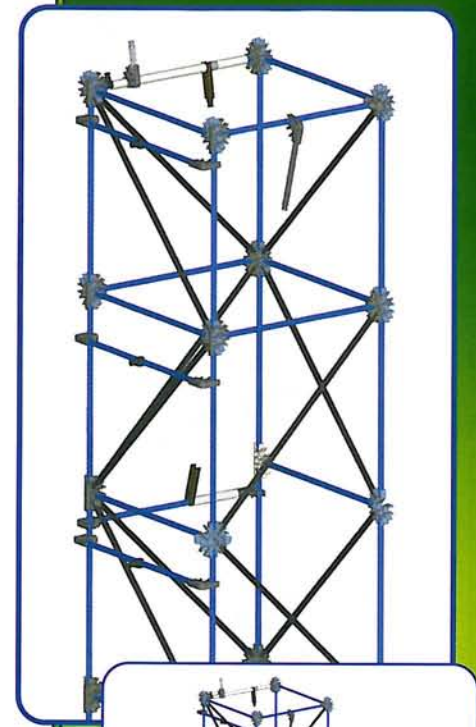
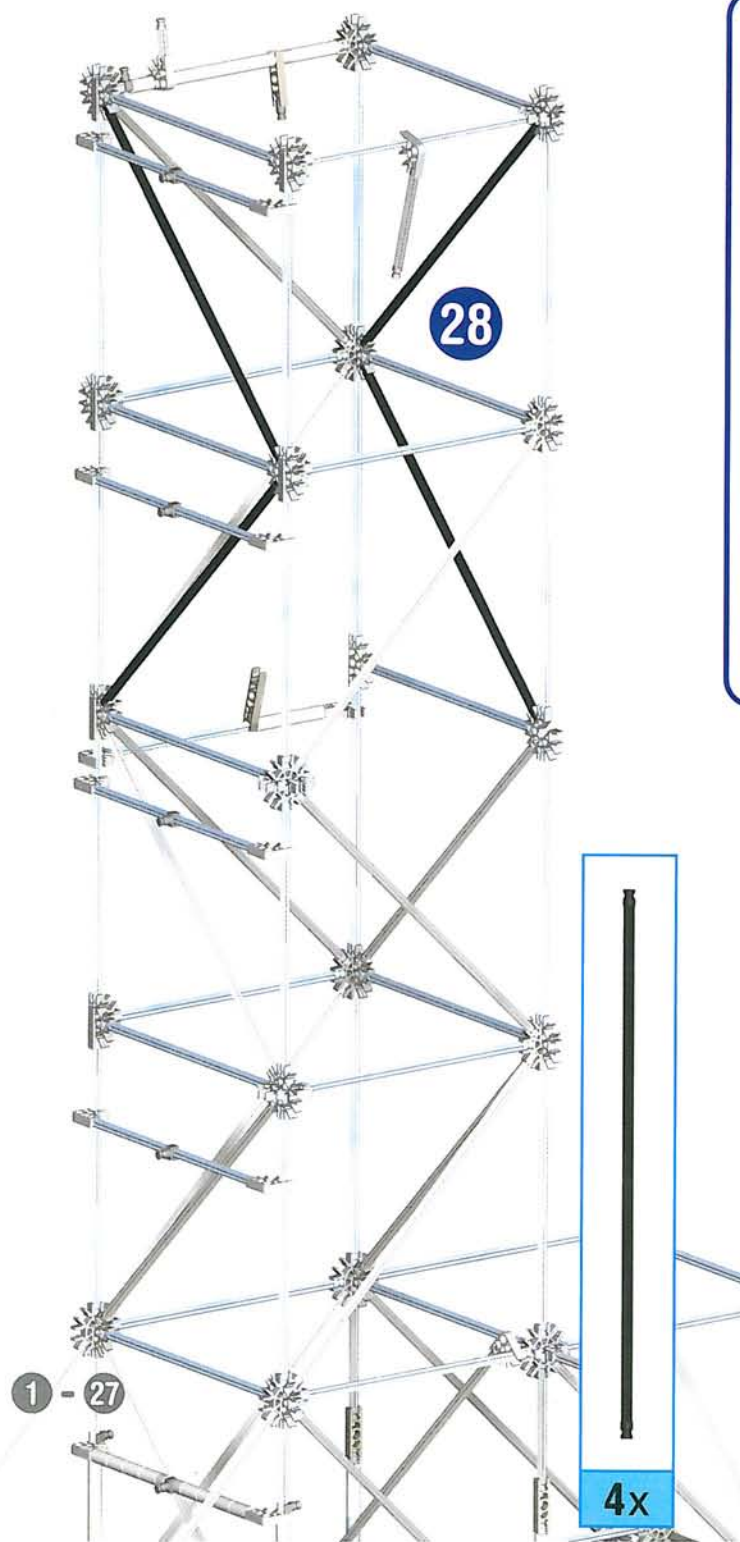
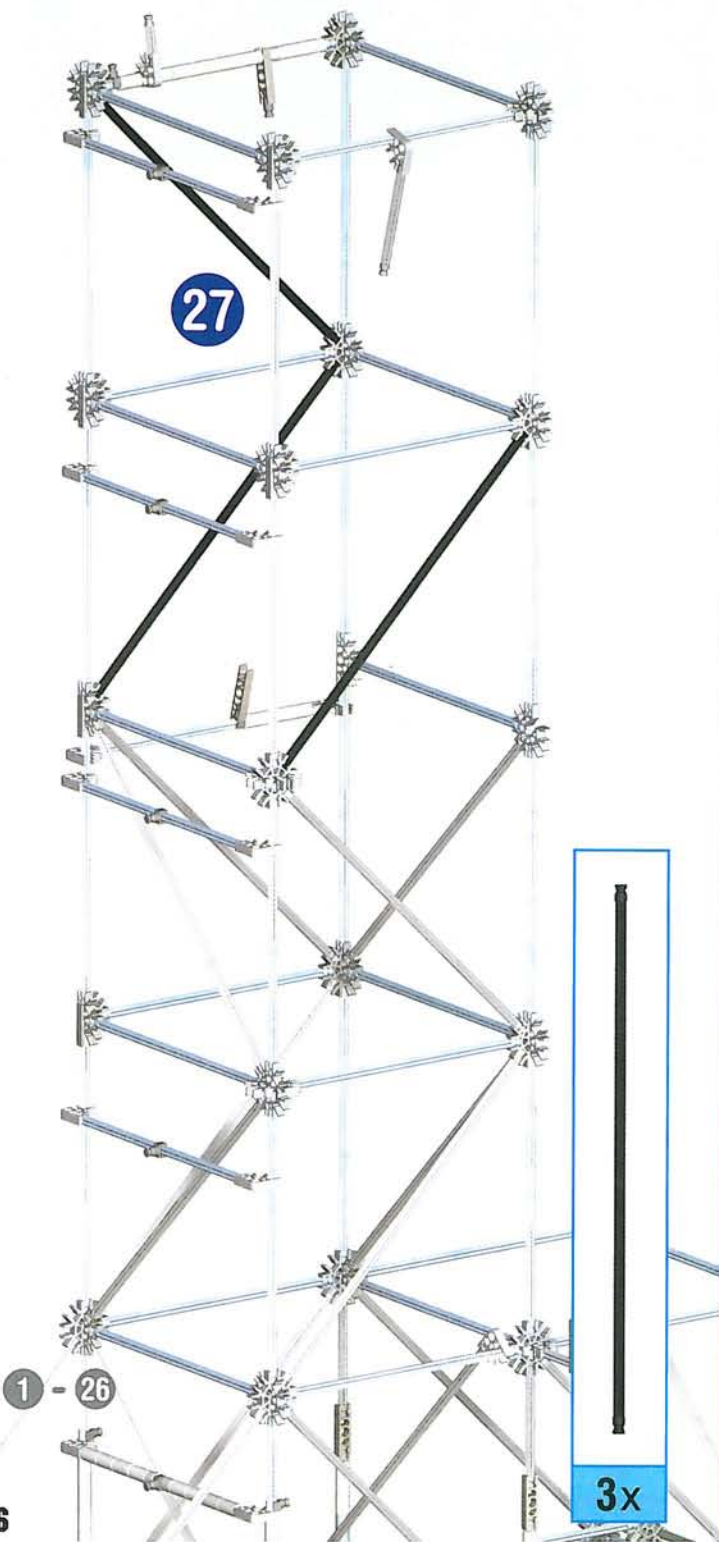

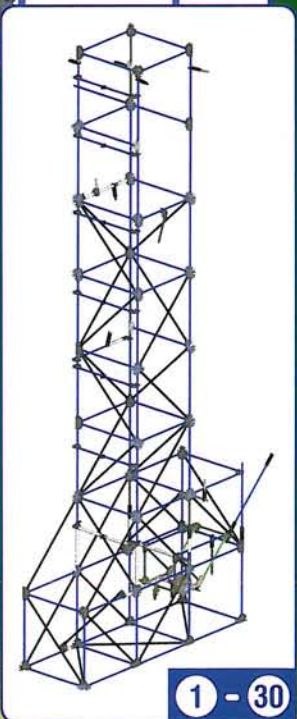
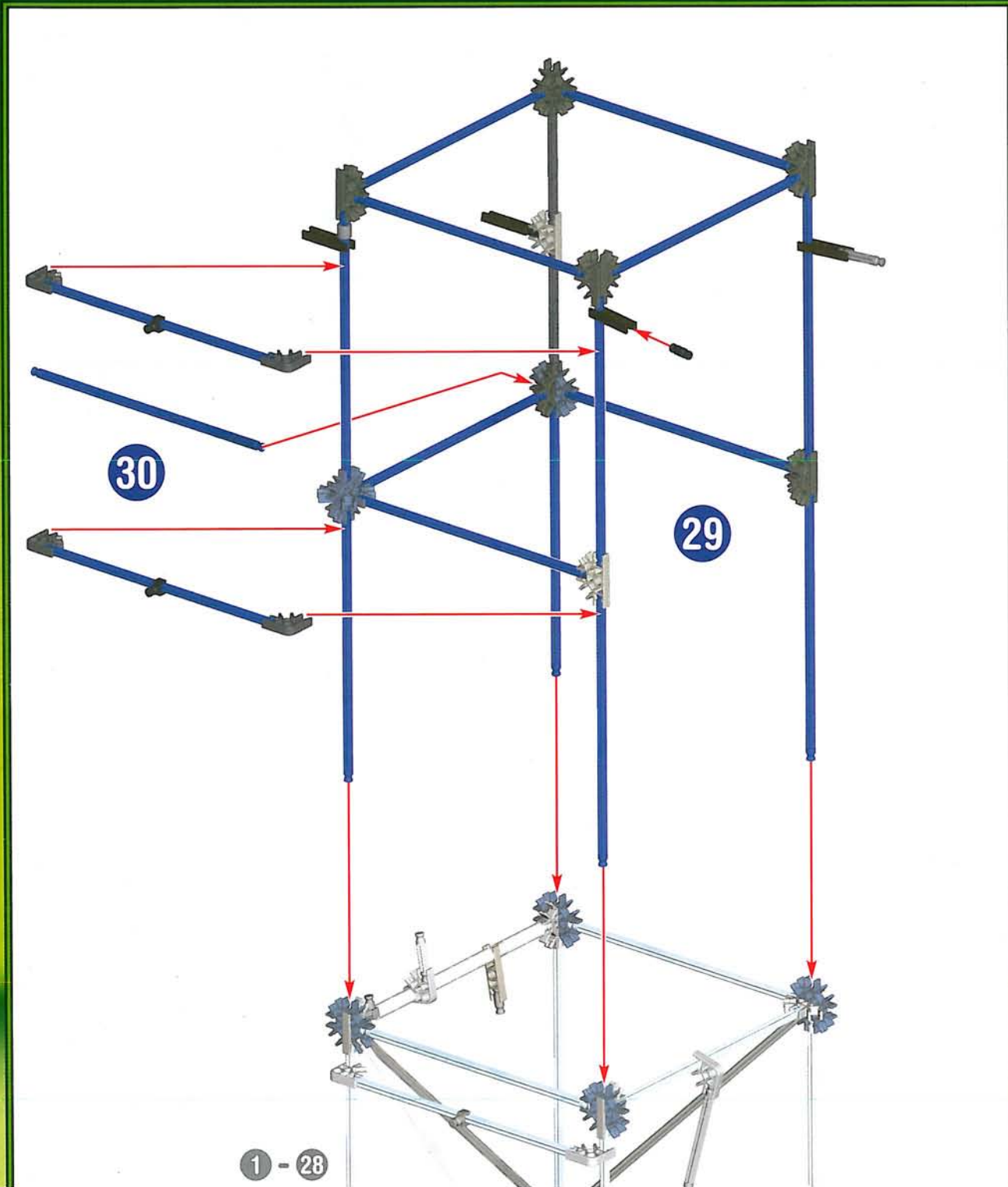

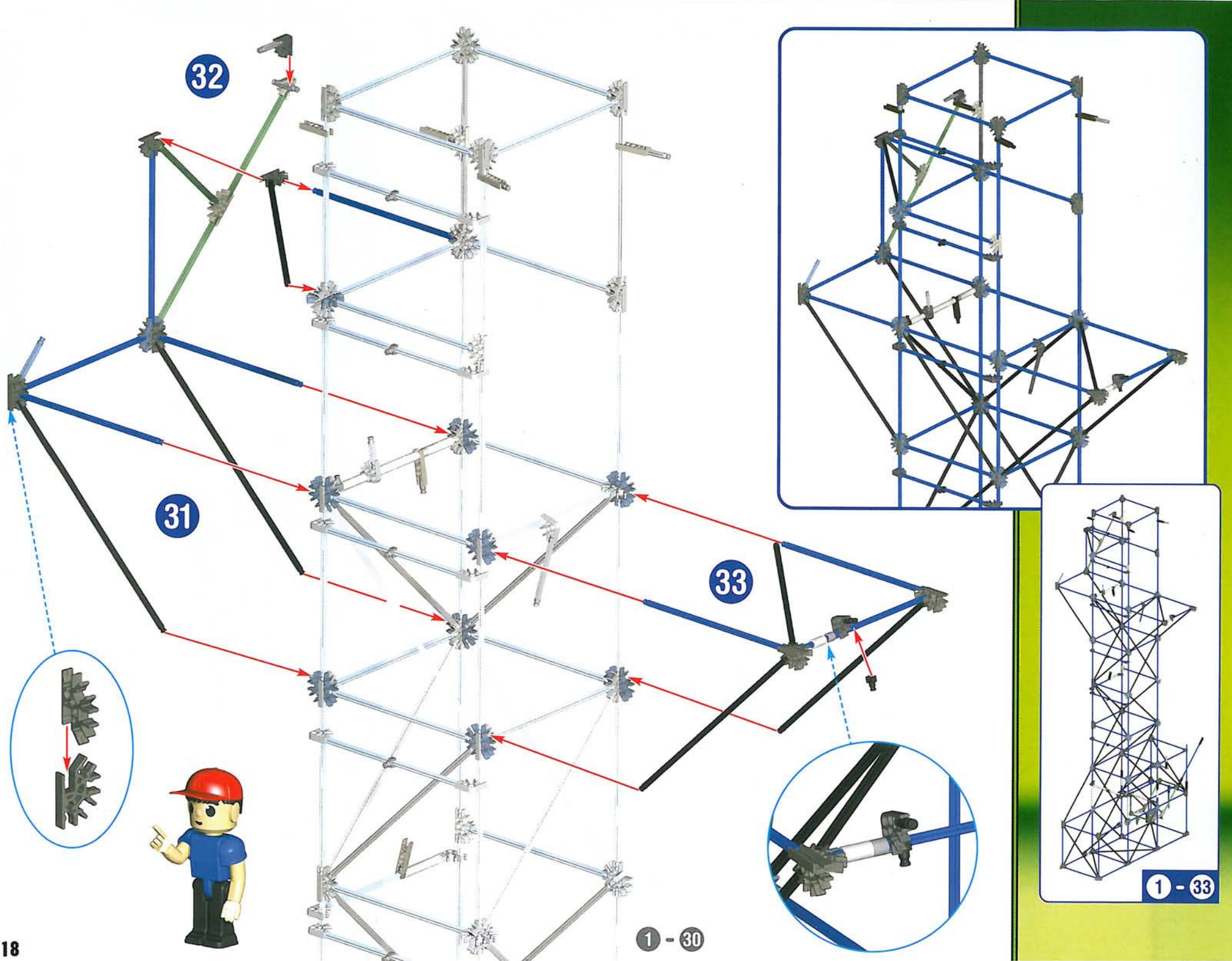

32

31

33

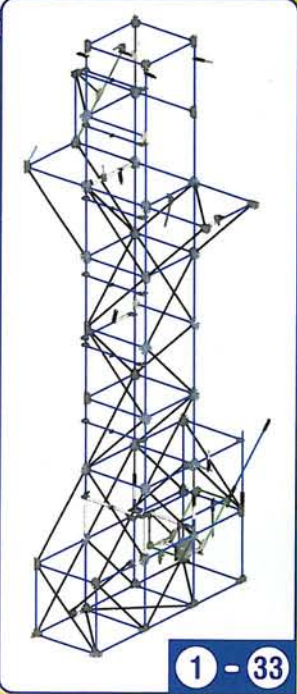
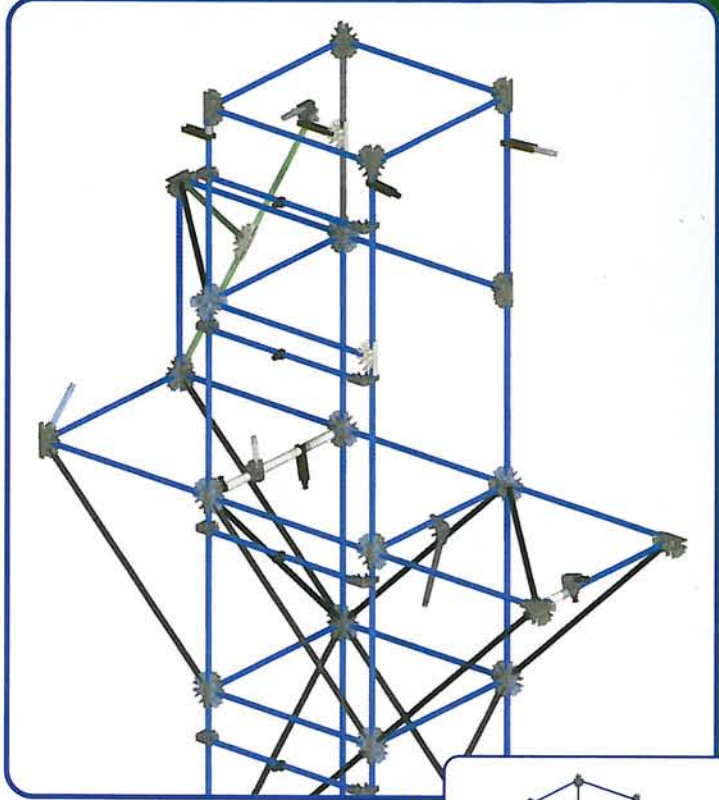

1 - 33

1 - 30

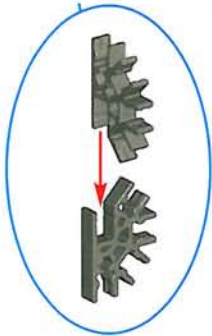

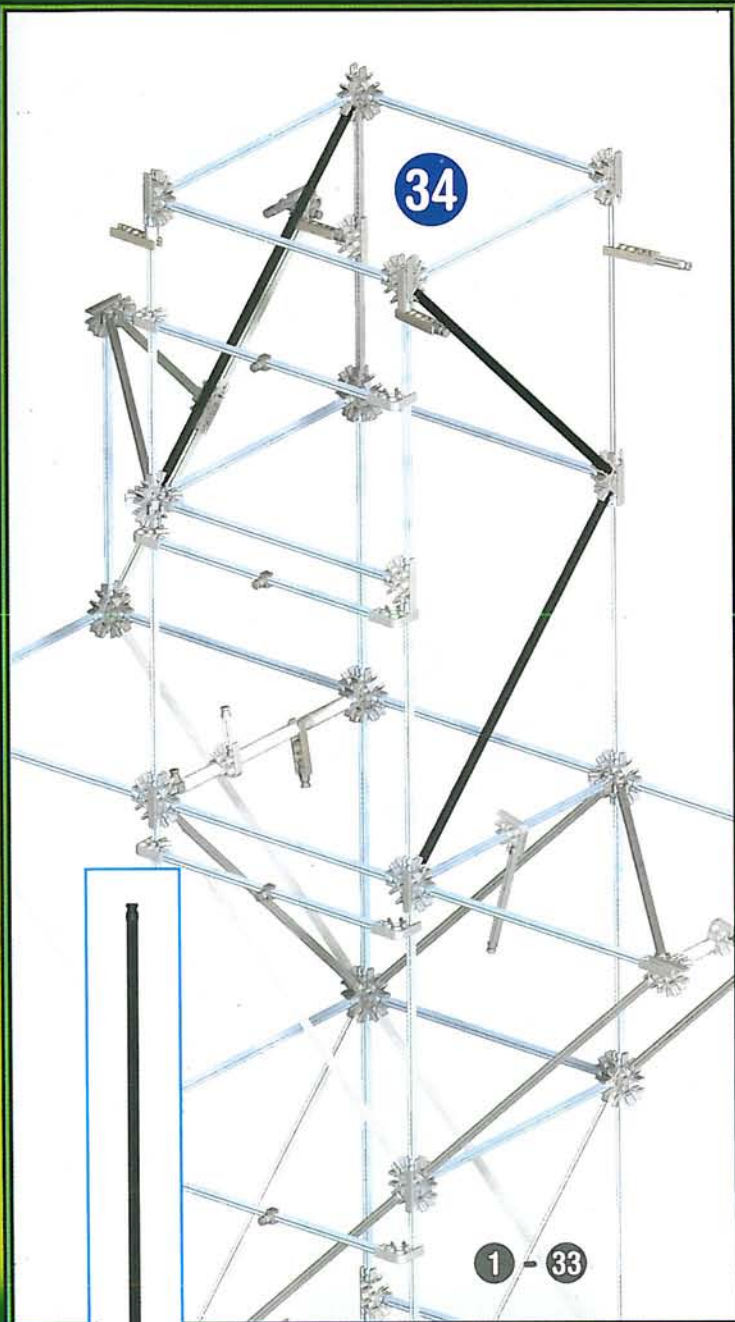

3x

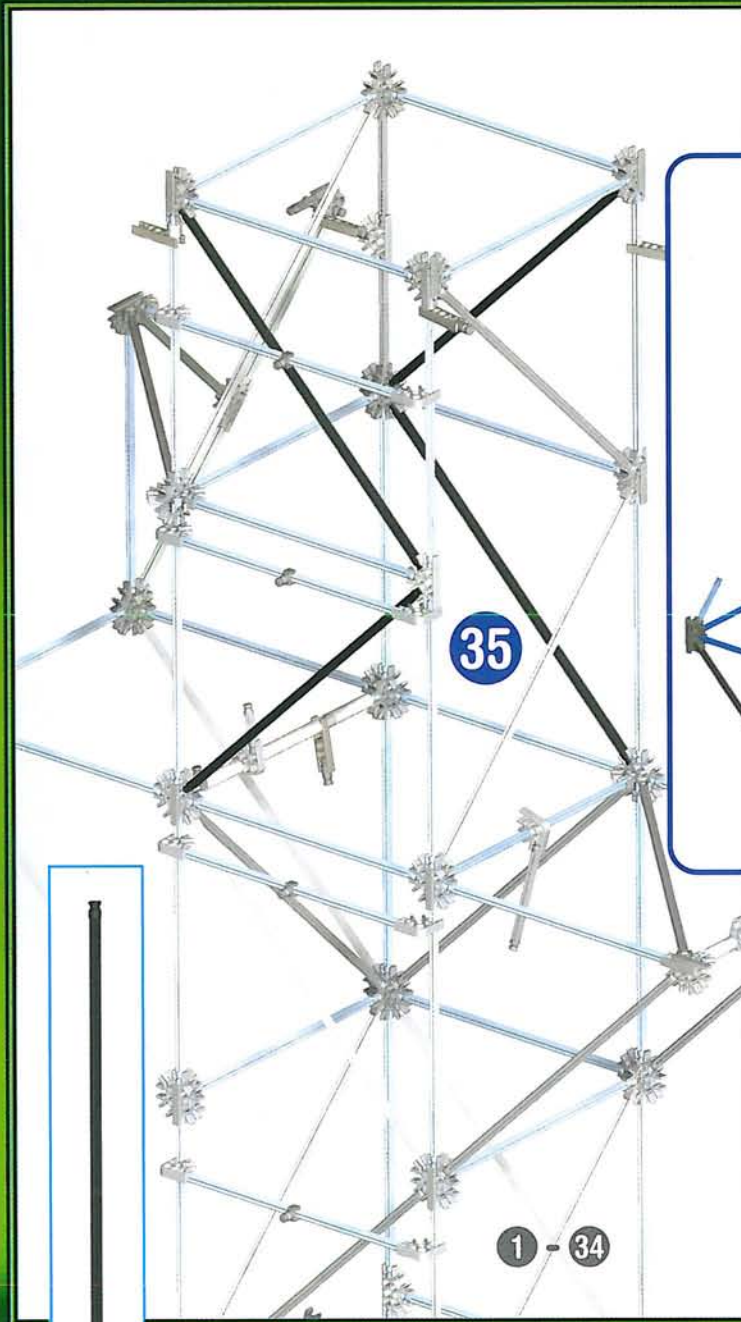

4x

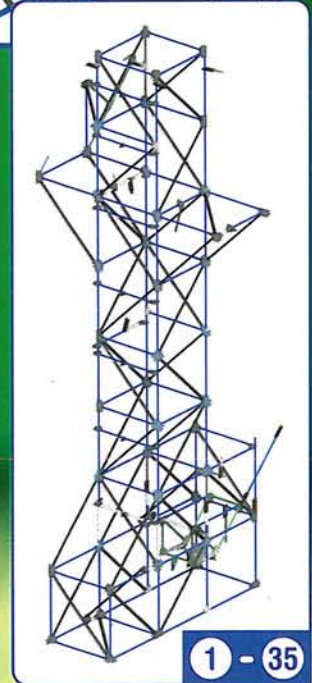
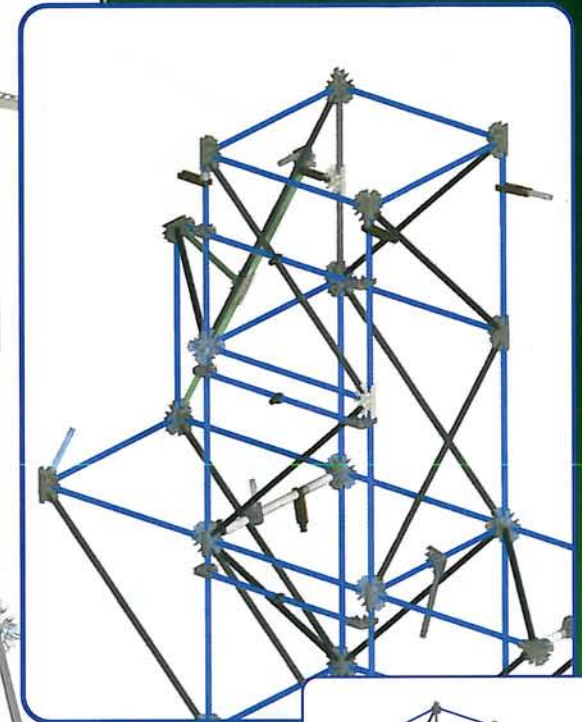

1 - 35

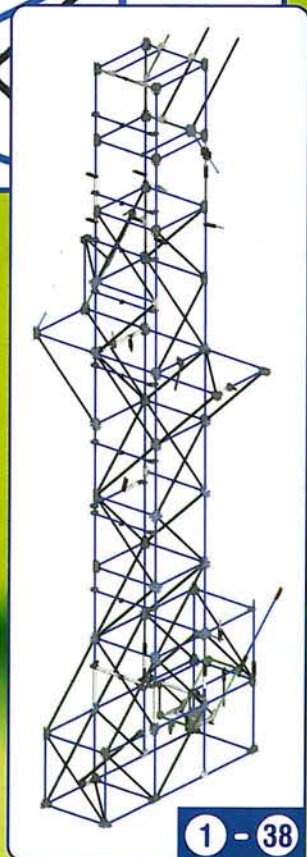
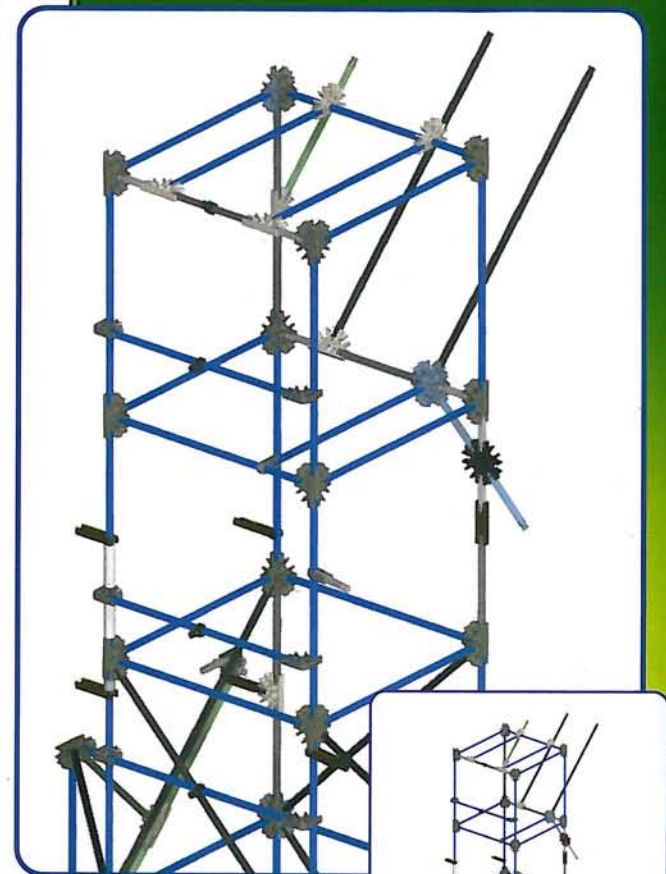
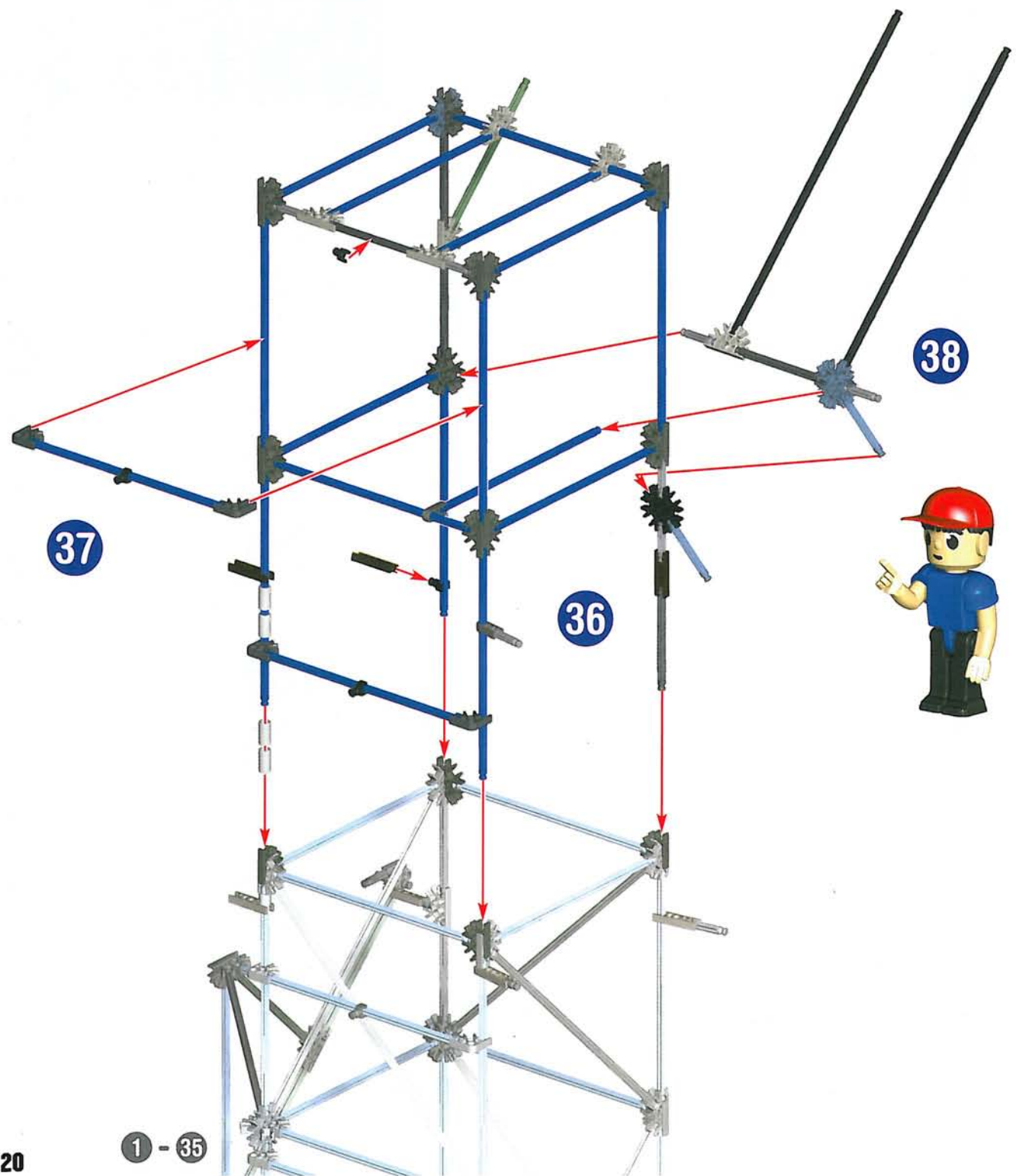

1 - 35

1 - 38

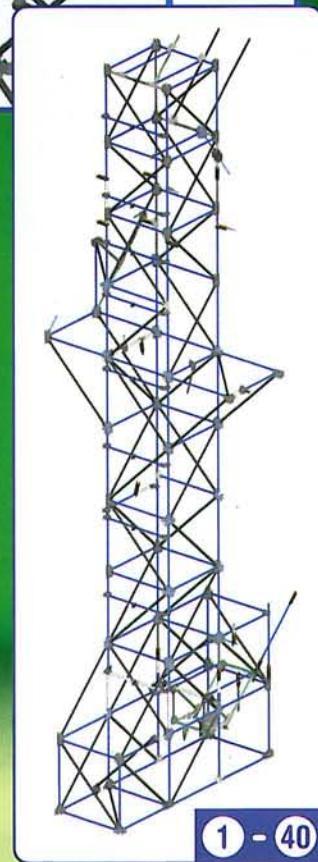
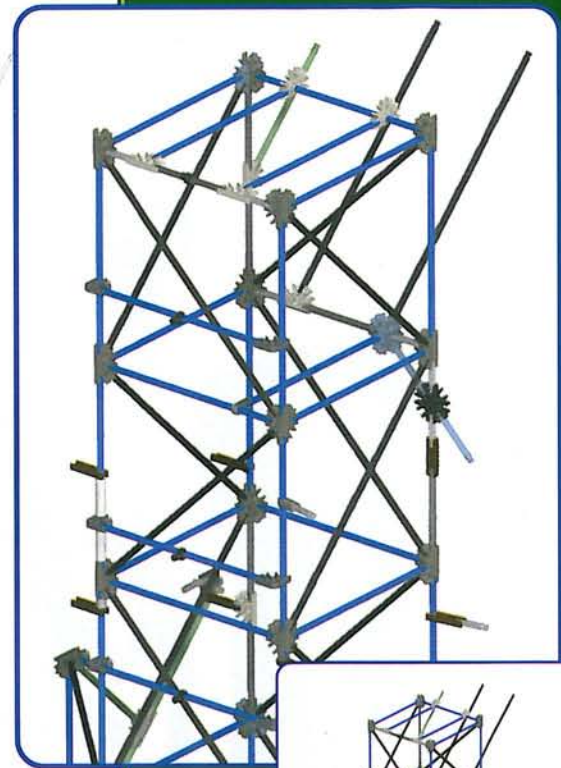
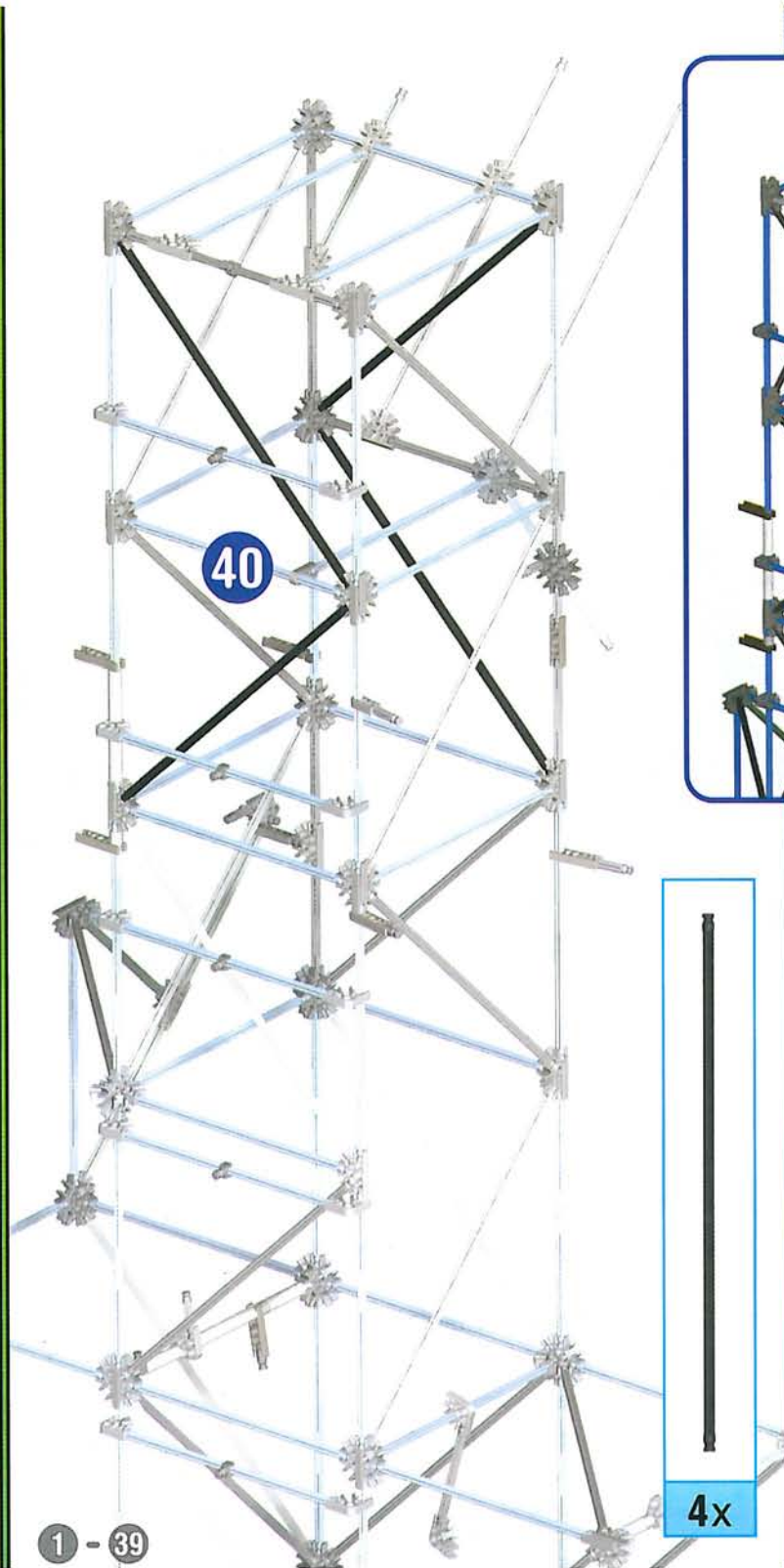
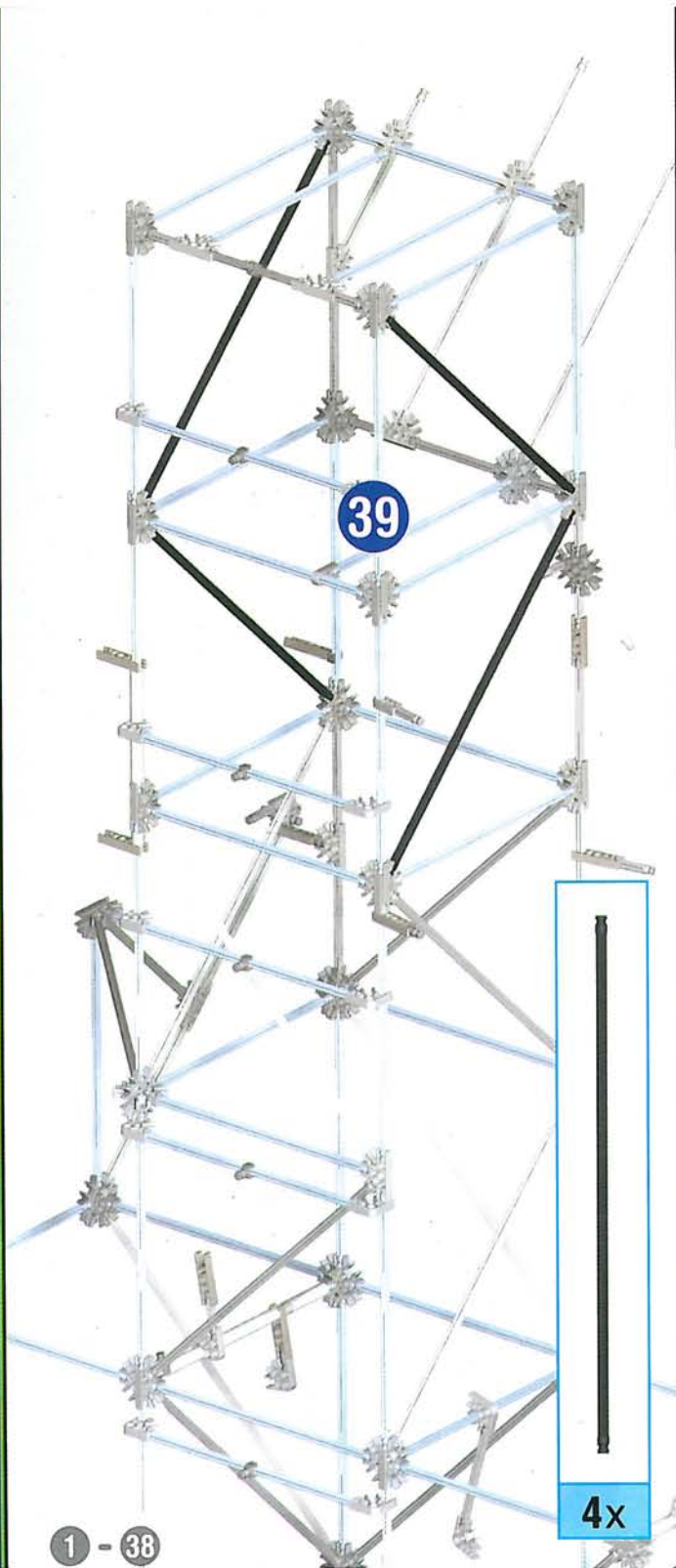

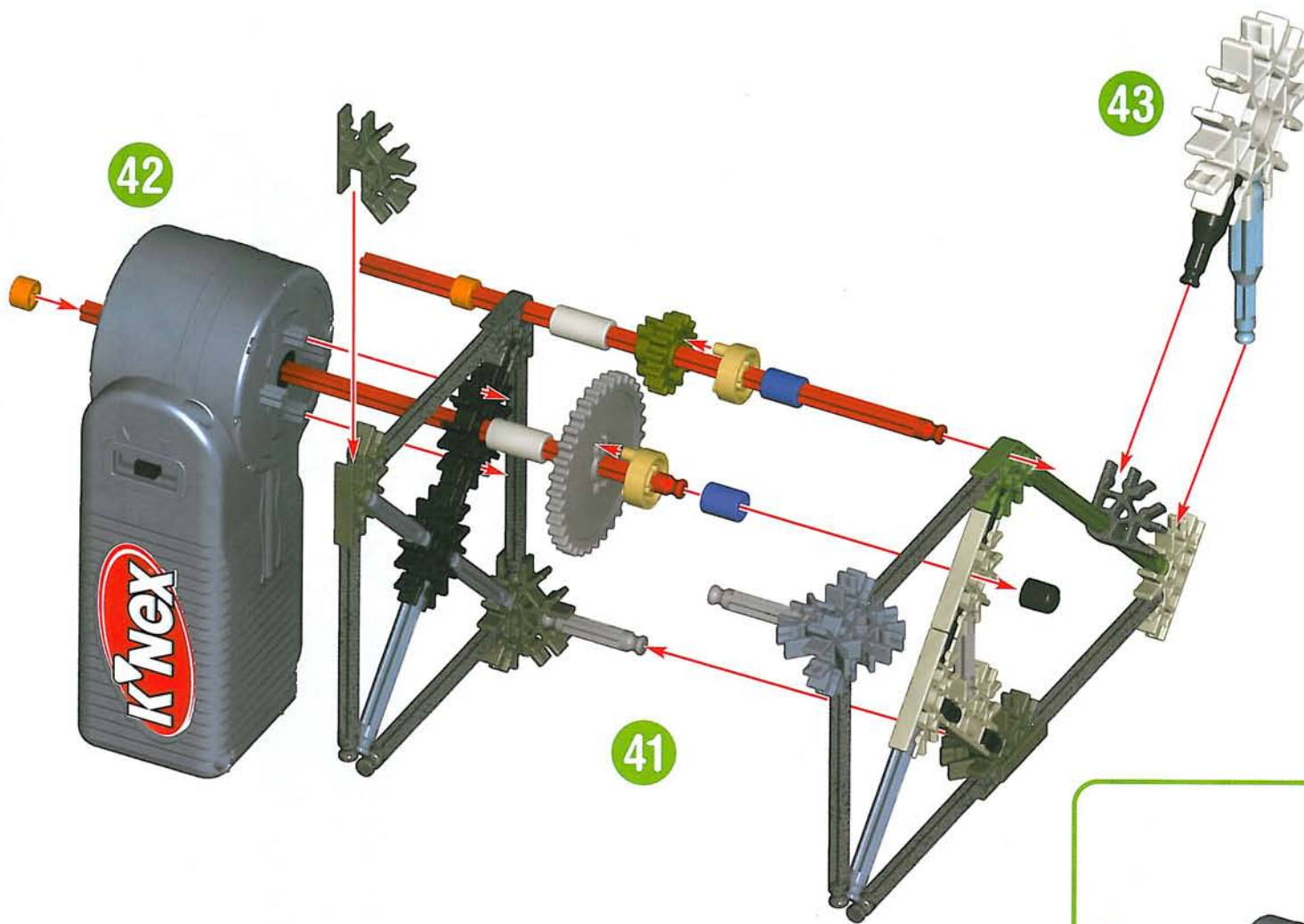

- (ENG) Make sure the gears mesh.
- (F) Vérifie que les engrenages s'enclenchent bien les uns dans les autres.
- (E) Asegúrate de que los engranajes concuerdan.
- (D) Vergewissere dich, dass die Zahnräder ineinander greifen.
- (NL) Verzeker je ervan dat de tandwielen in mekaar passen.
- (I) Assicurarsi gli ingranaggi ingranano.
- (P) Assegure-se de que malha de engrenagens.



- (ENG) Did you install 2 AA (or LR6) batteries in the Motor?
- (F) Est-ce que tu as installé 2 piles AA (ou LR6) dans le moteur ?
- (E) ¿Instalaste dos pilas AA (o LR6) en el Motor?
- (D) Heb je 2 AA (of LR6) batterijen gestoken in de motor?
- (NL) Heb je er 2 AA (of LR6) batterijen ingestoken?
- (I) Hai installato 2 batterie AA (o LR6) nel motore?
- (P) Foram instaladas as pilhas 2 AA (ou LR6) no Motor?



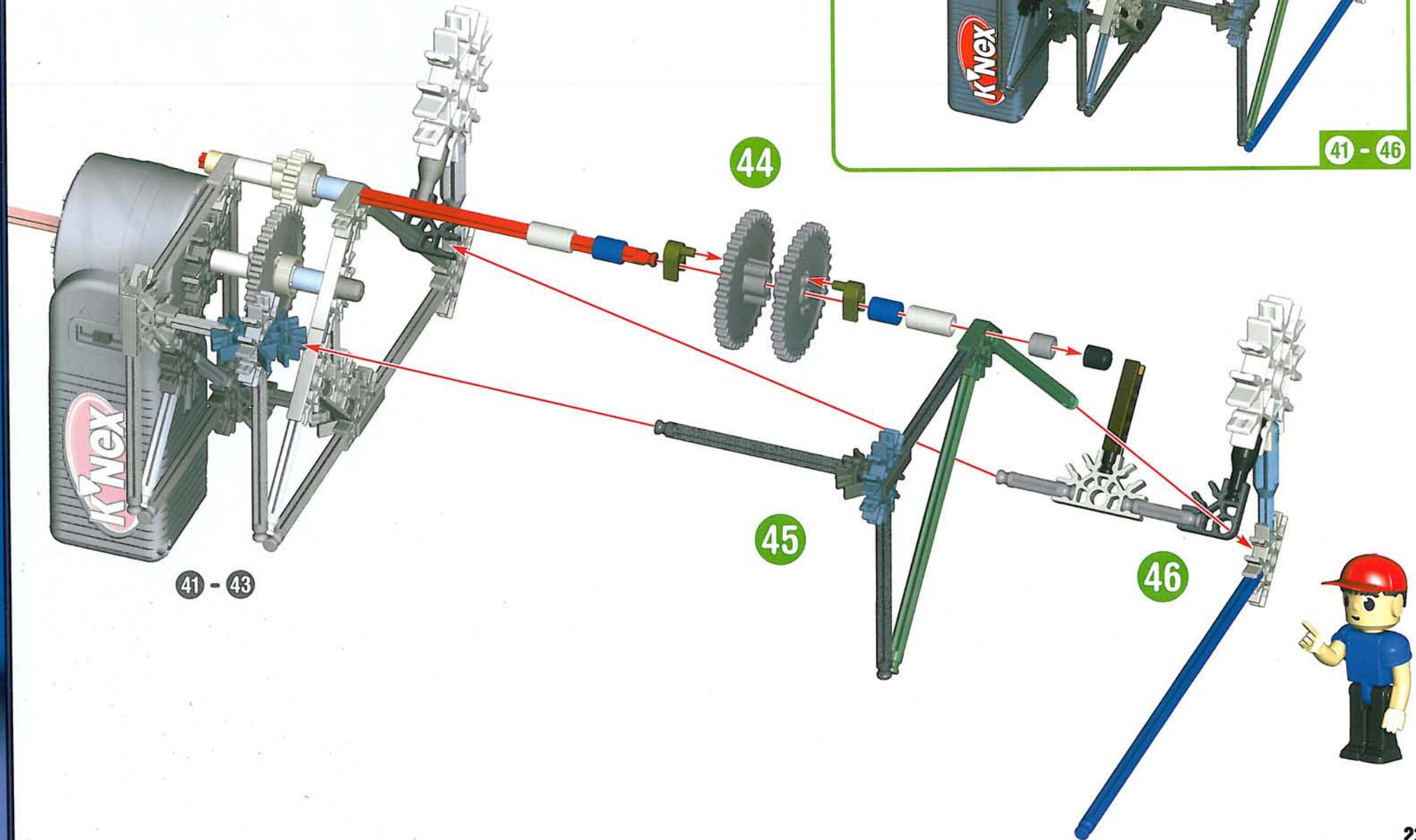

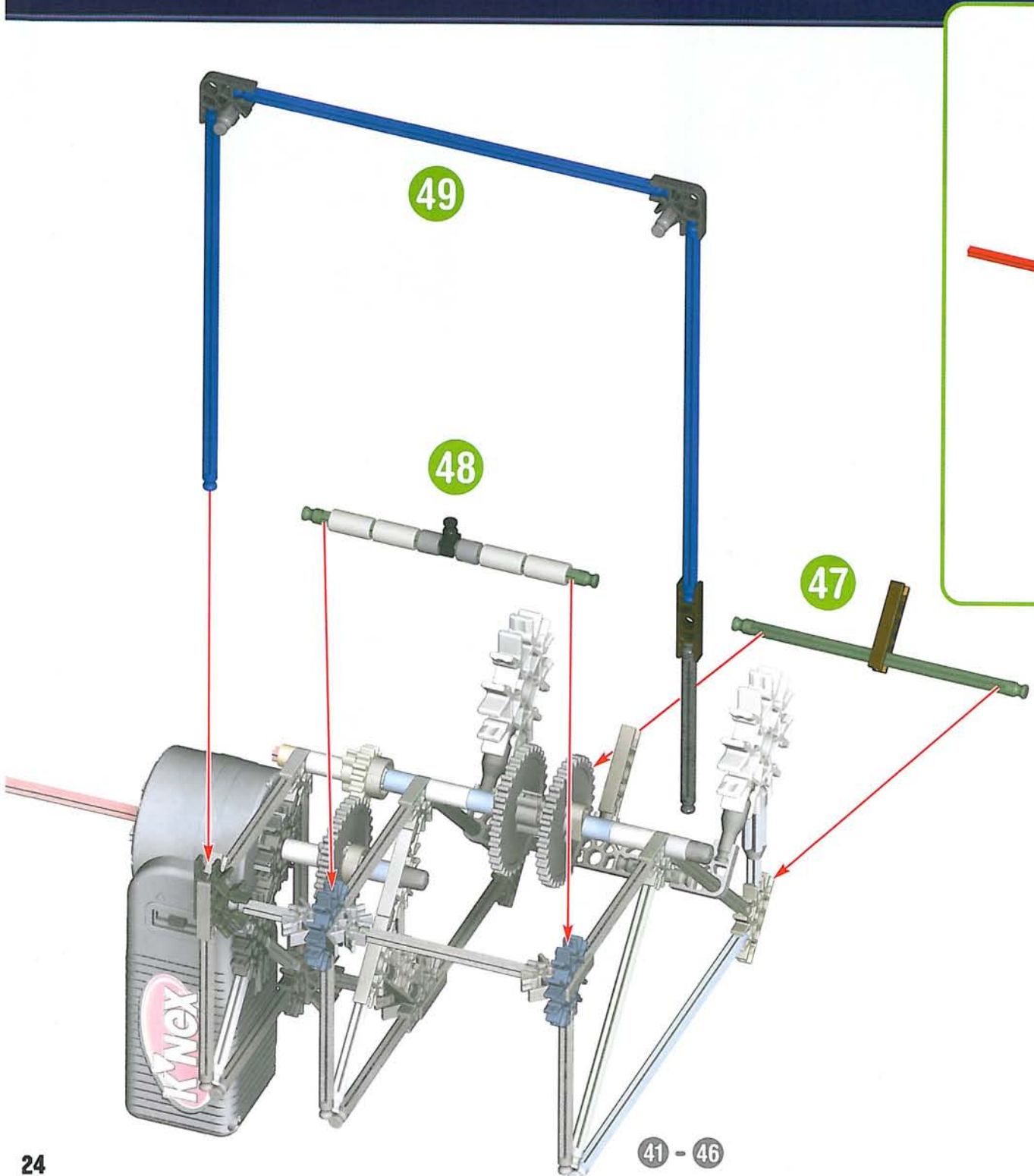

41 - 49

41 - 46

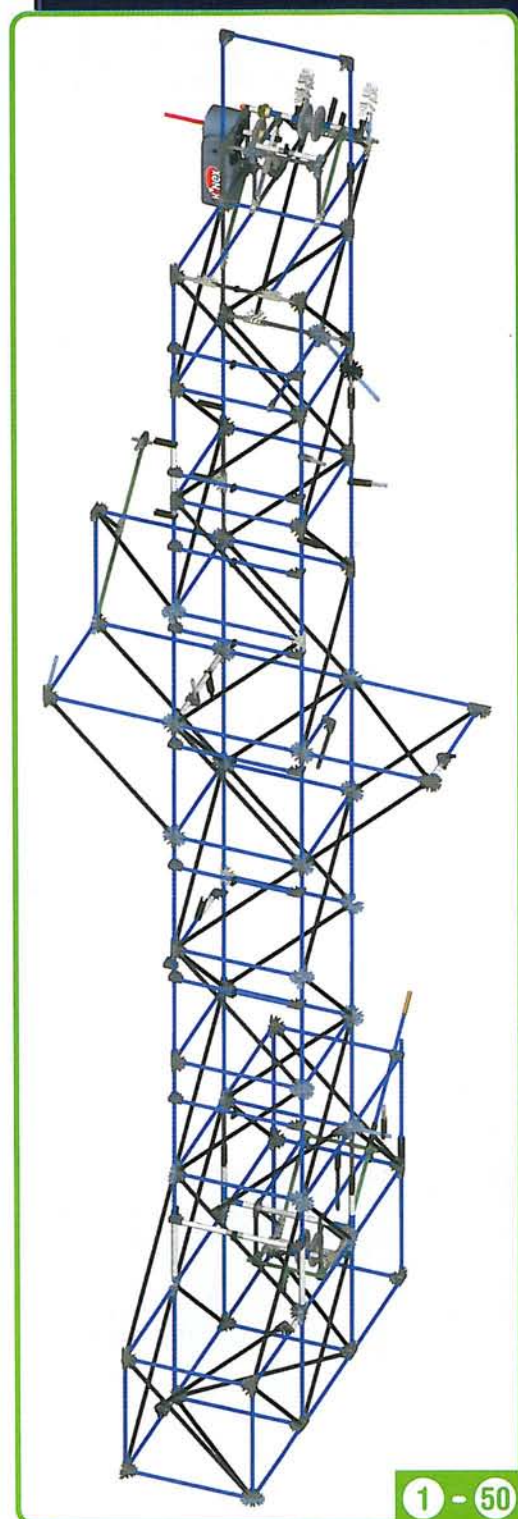
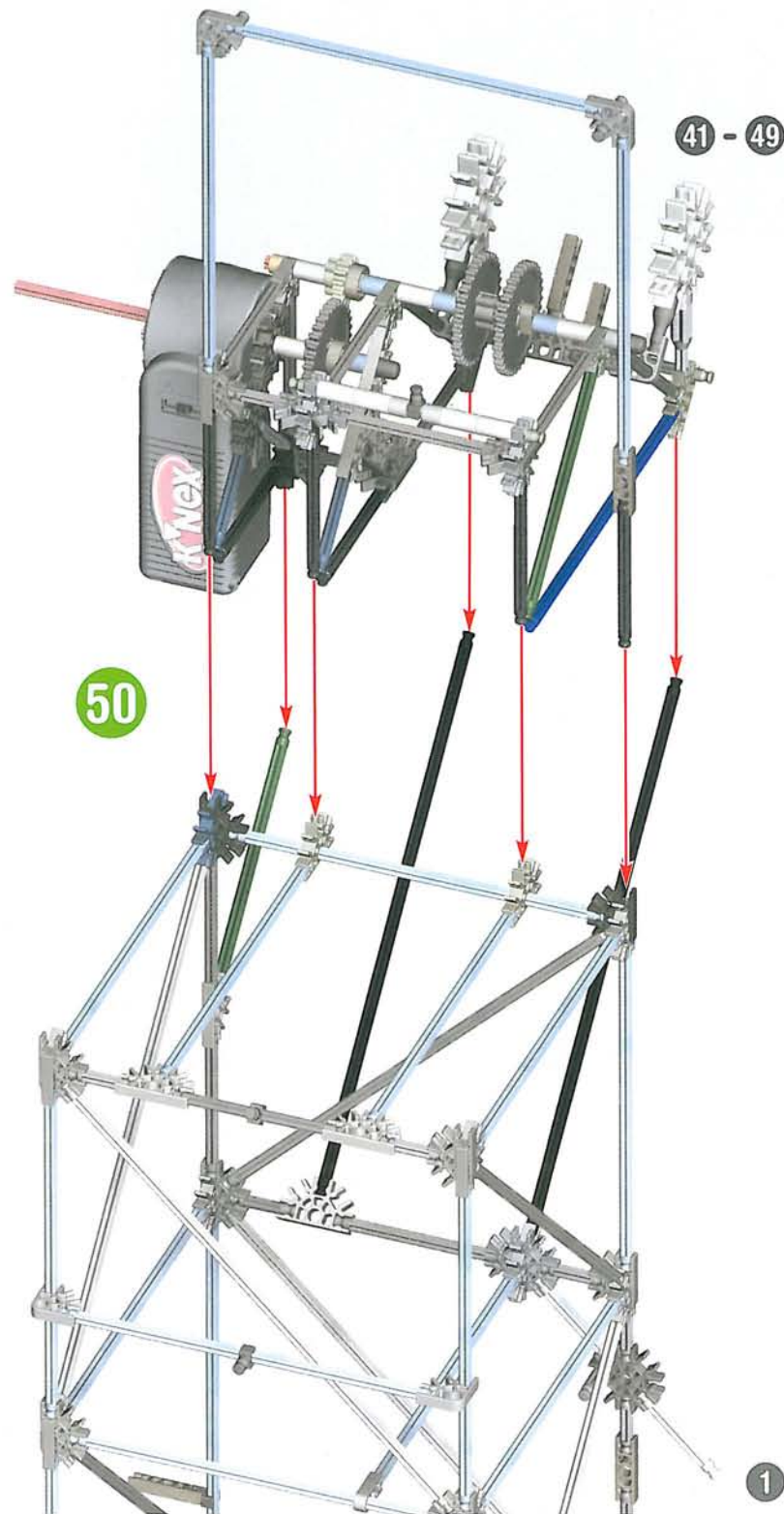

VERTICAL VENGEANCE: (ADVANCED BUILD)

TOWER 2

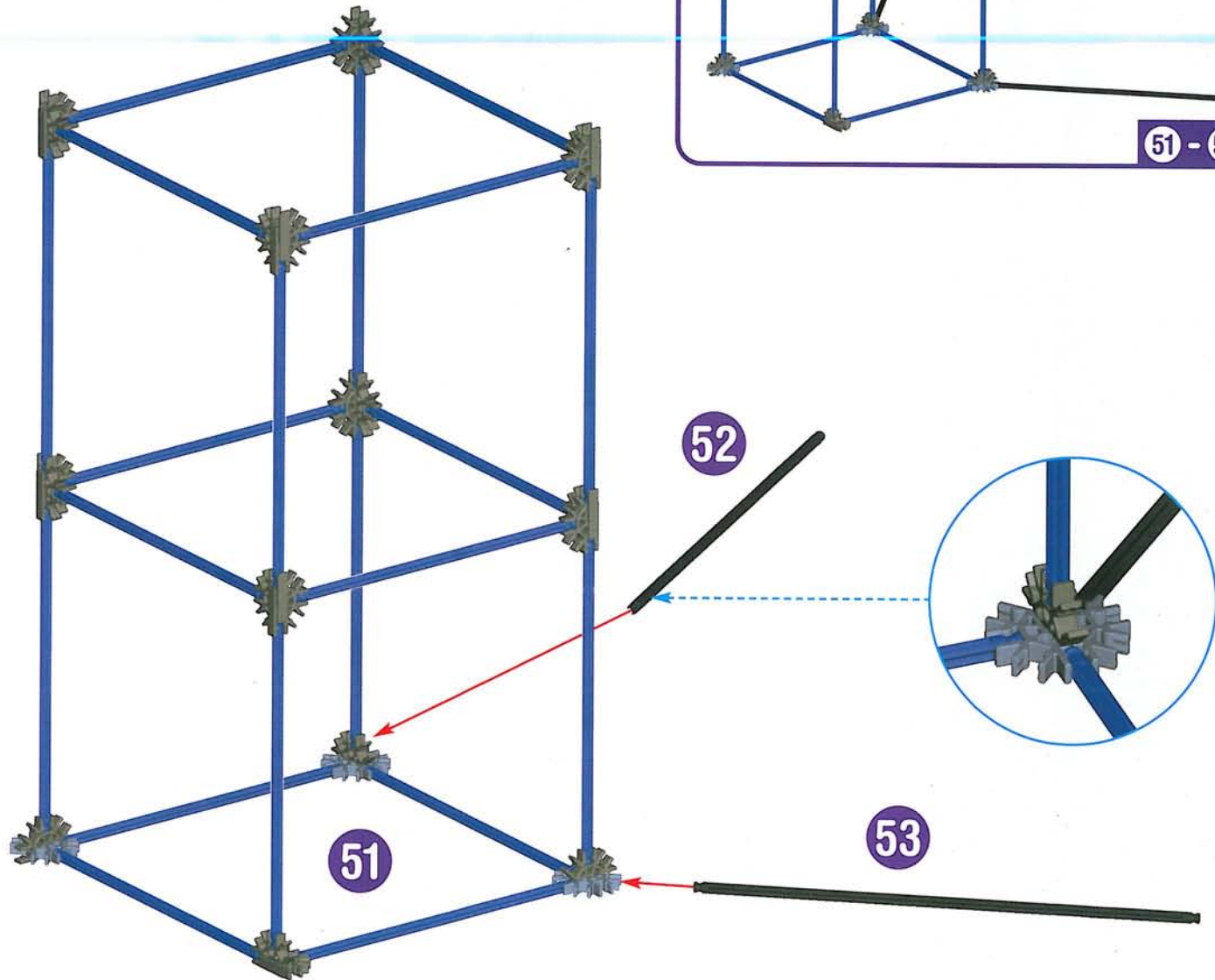
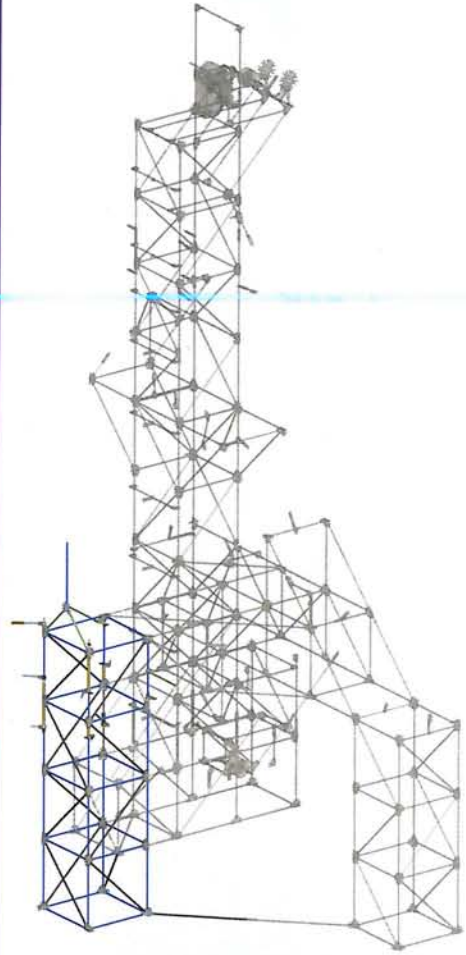

51 - 53

52

51

53



4x

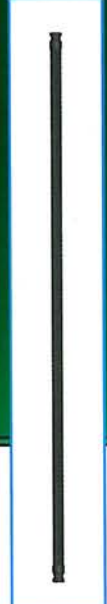
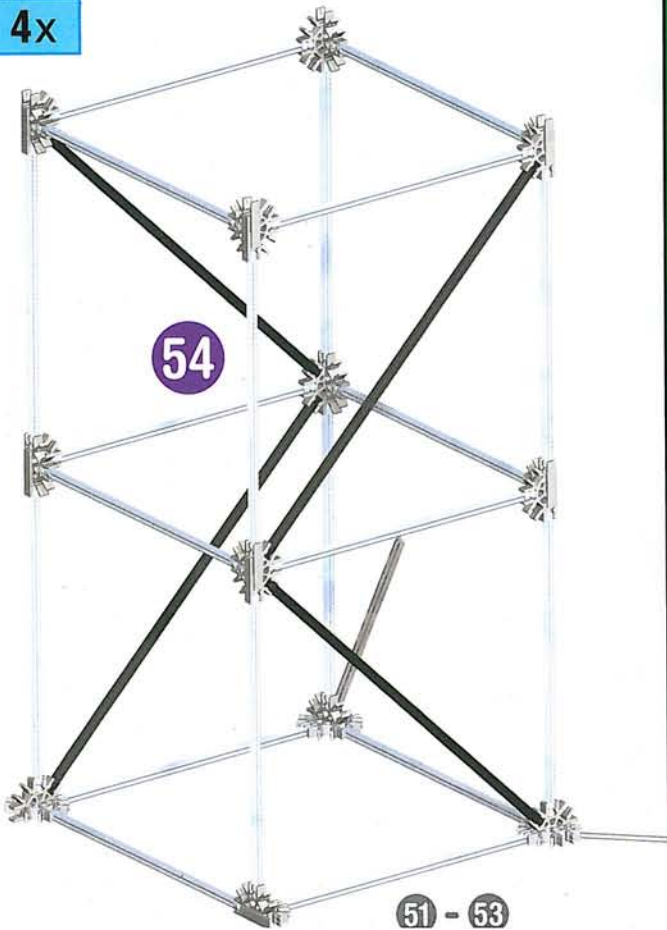

2x

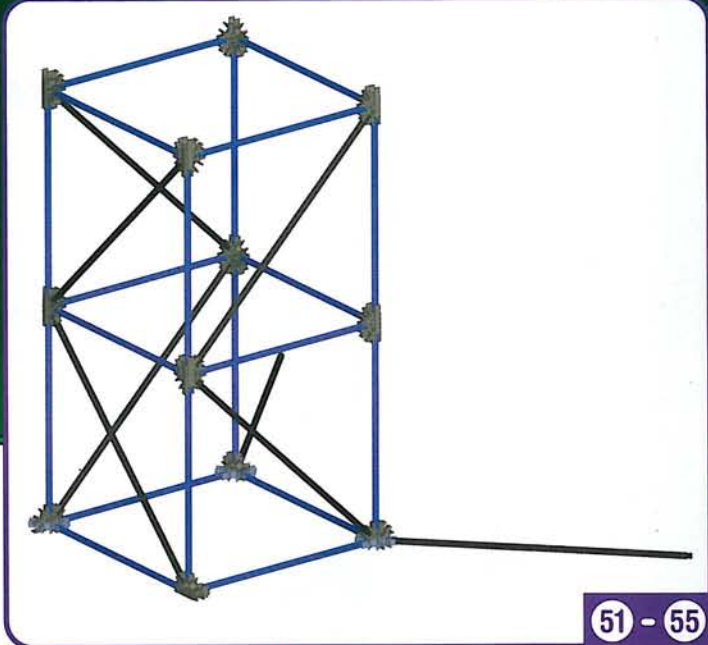

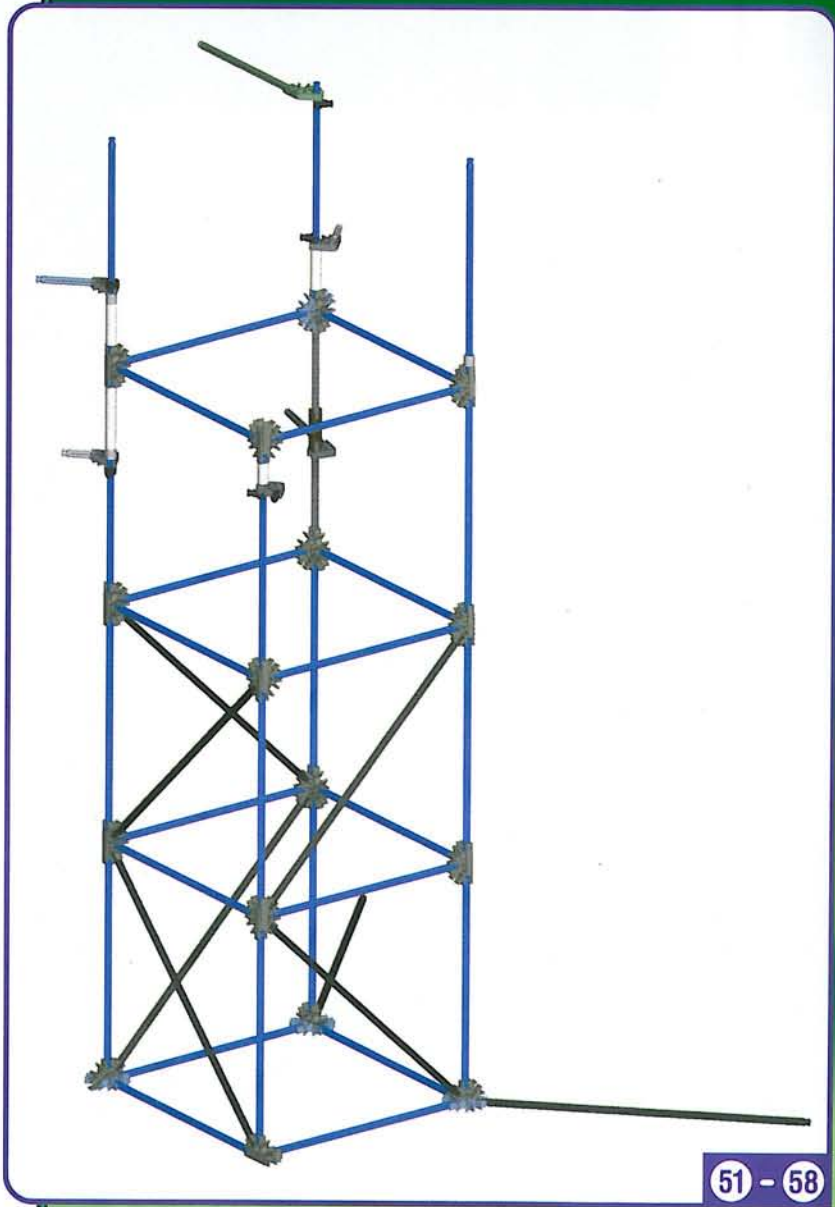
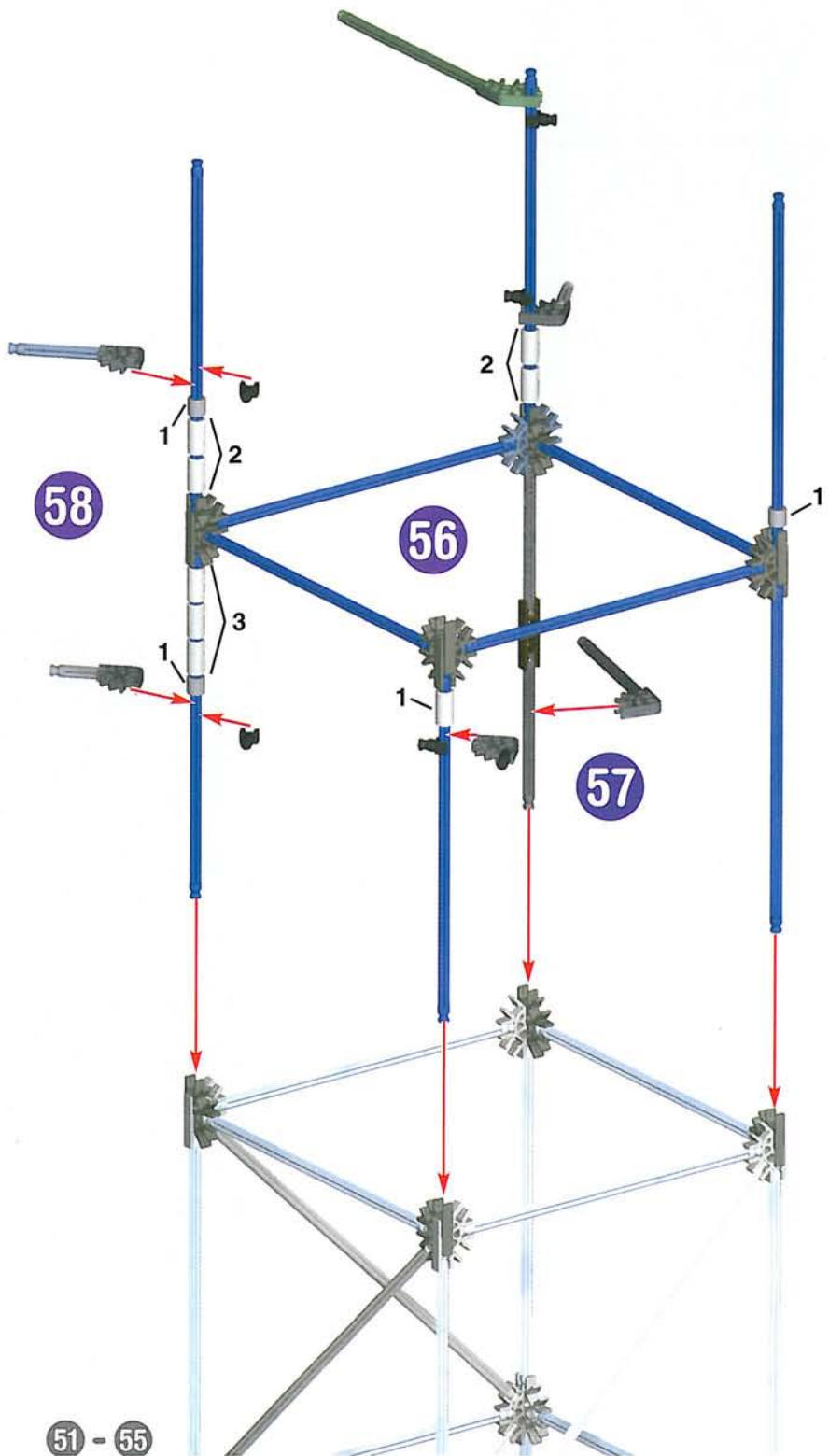

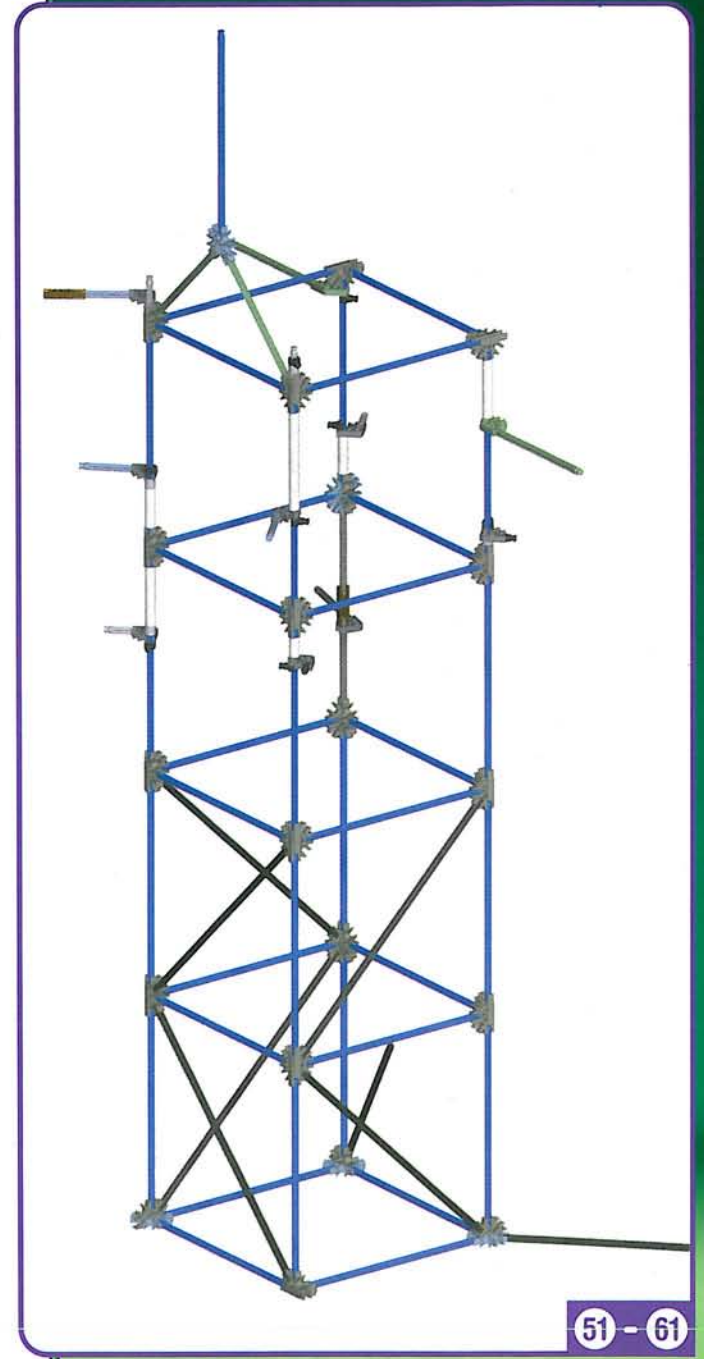
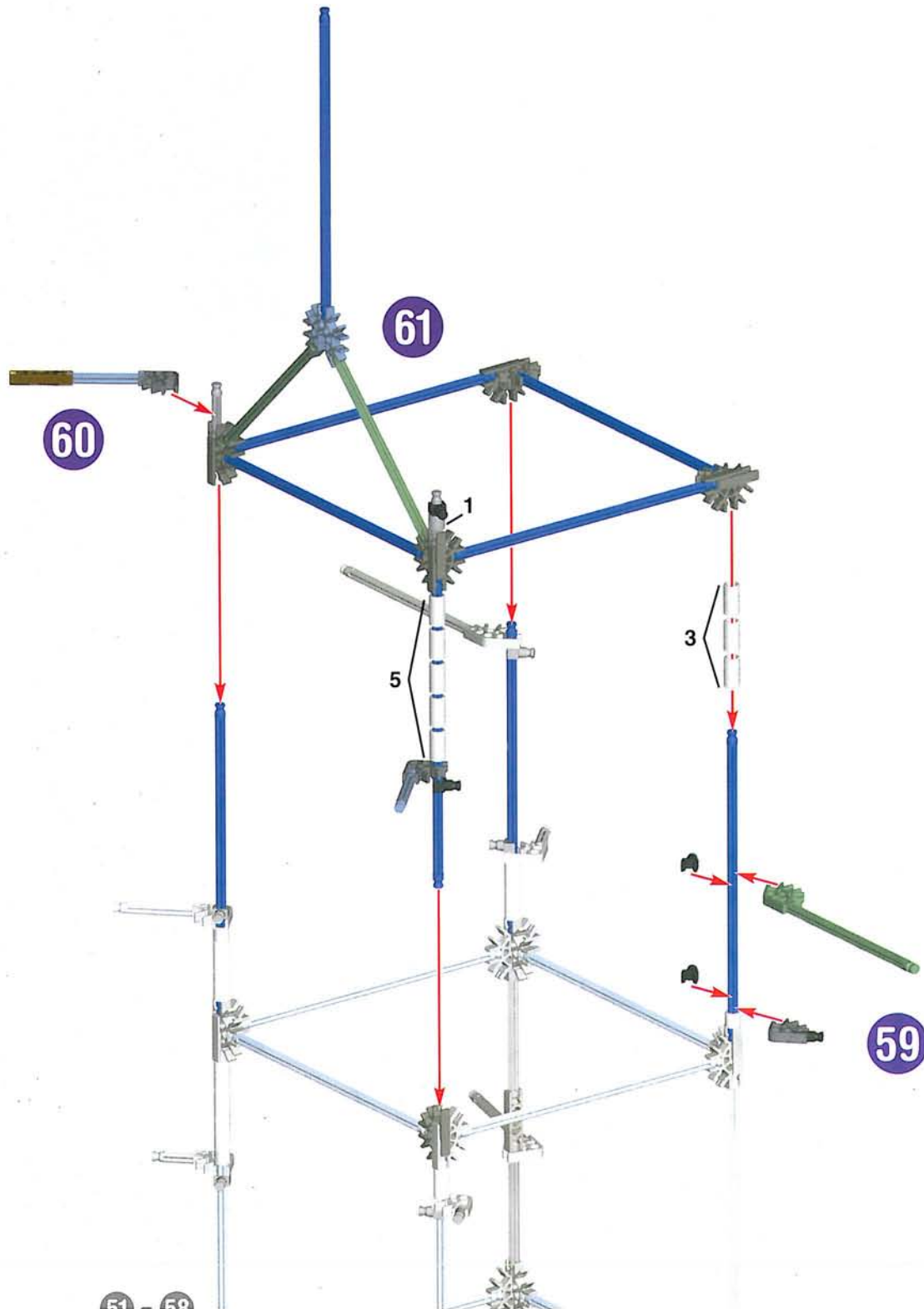

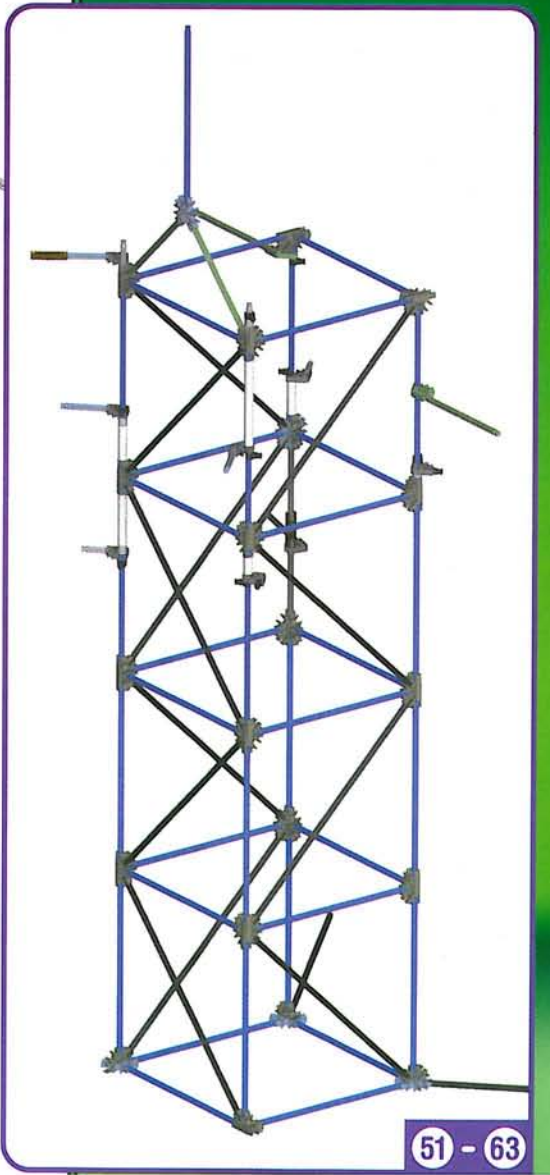
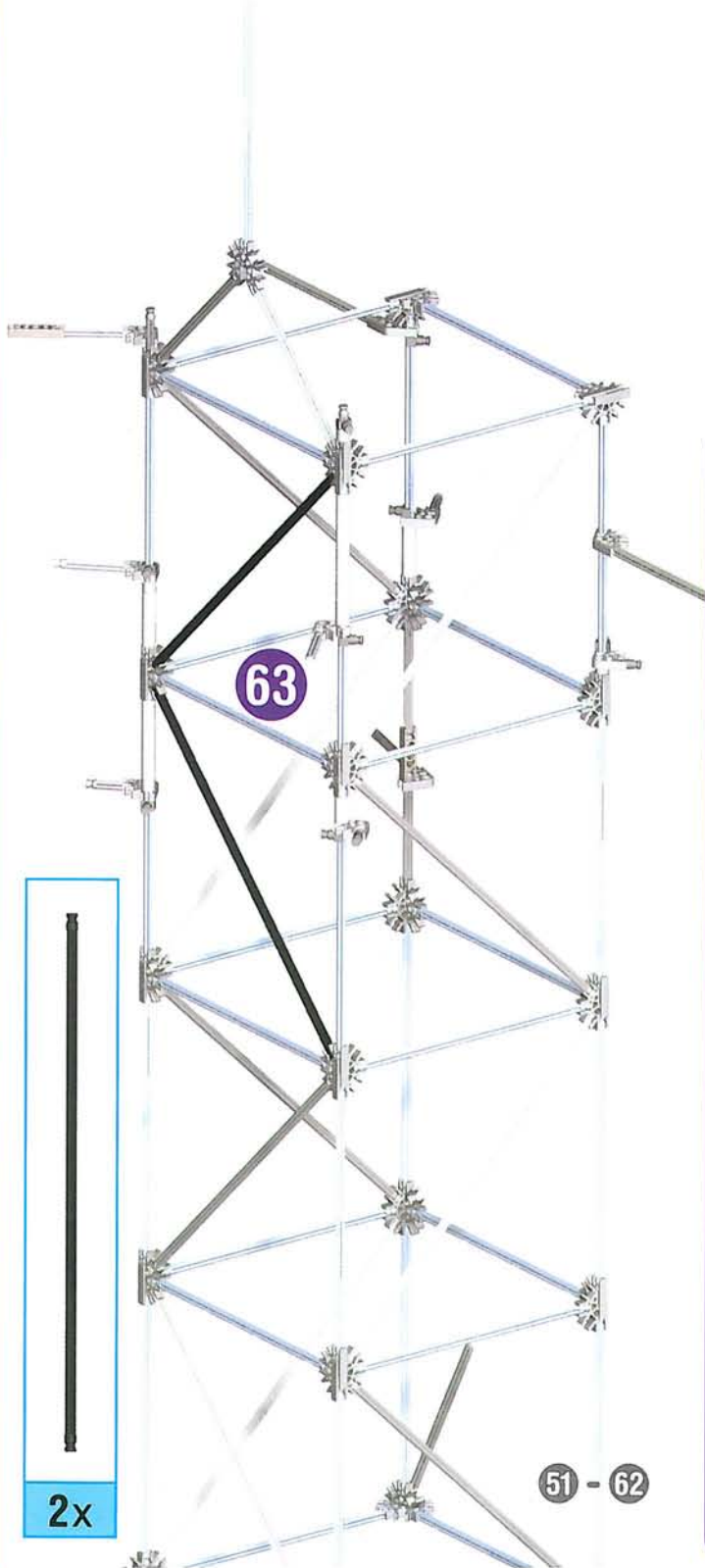
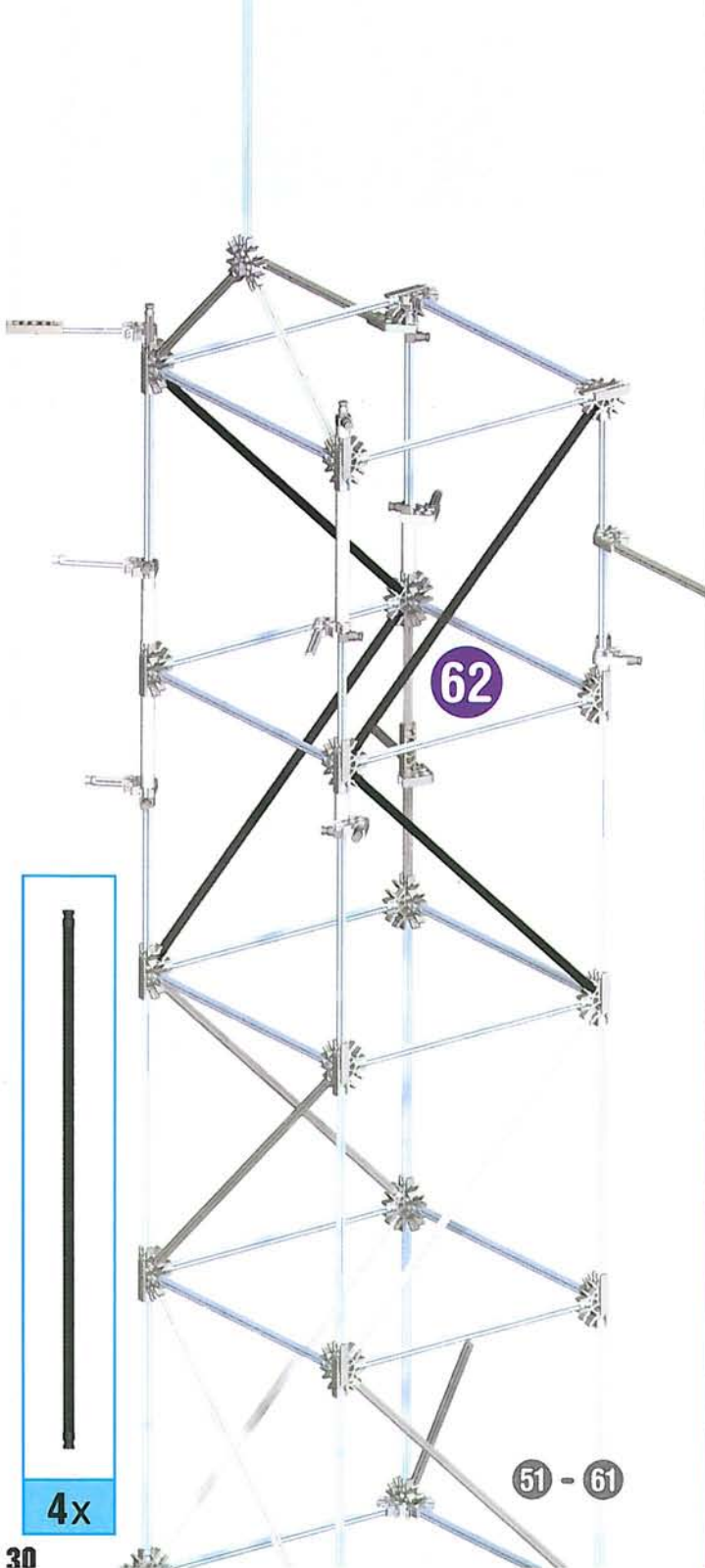

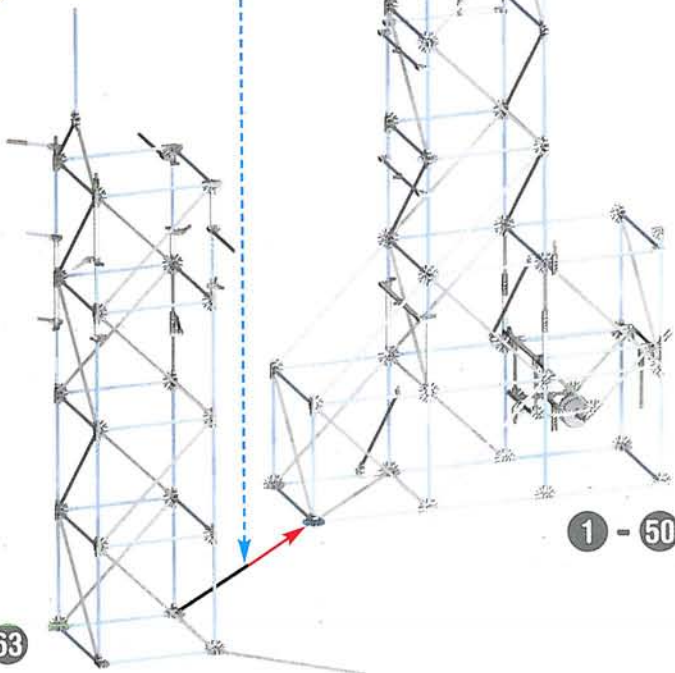
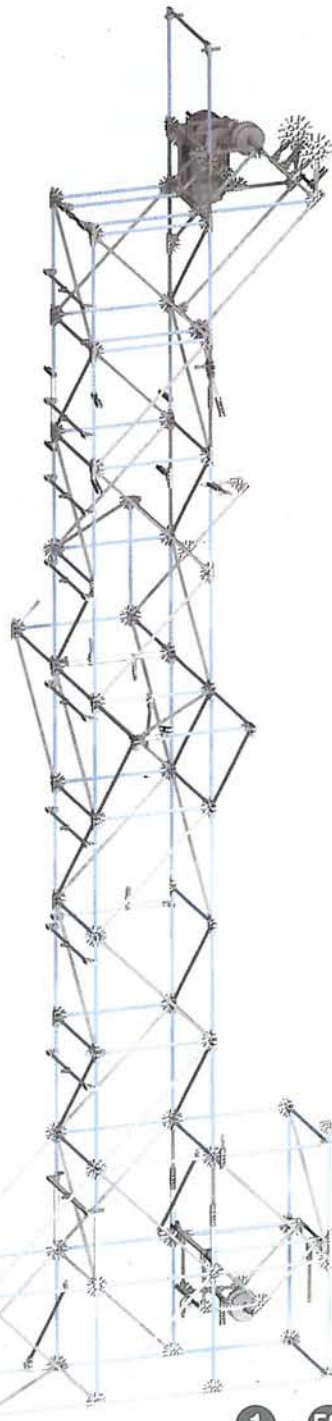
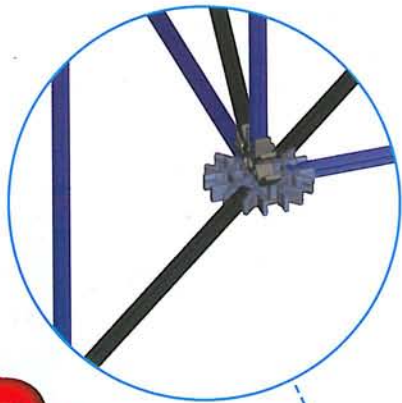

1 - 50

51 - 63

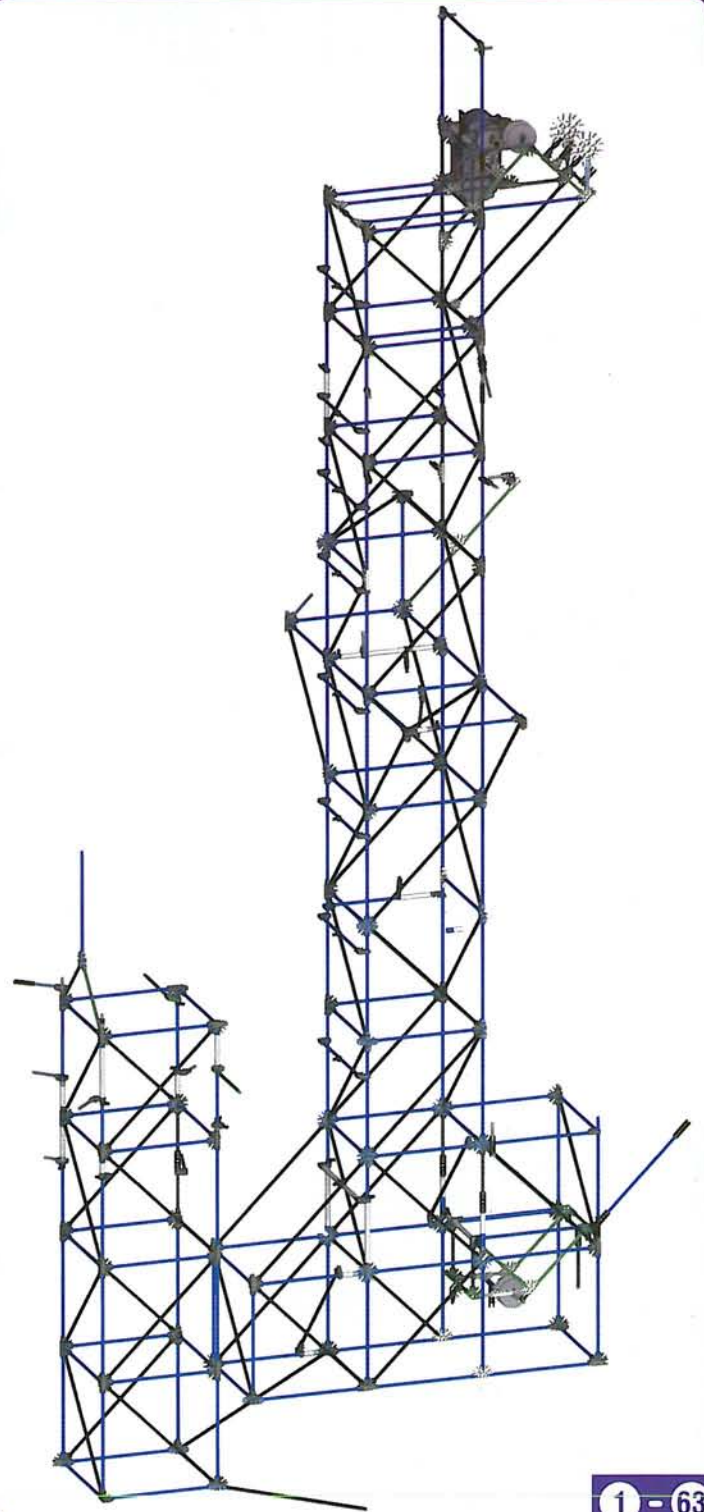

1 - 63

VERTICAL VENGEANCE: (ADVANCED BUILD)

MIDDLE

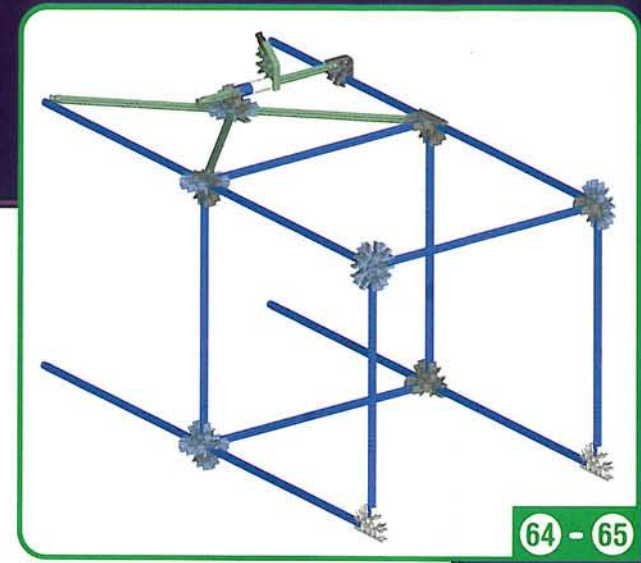
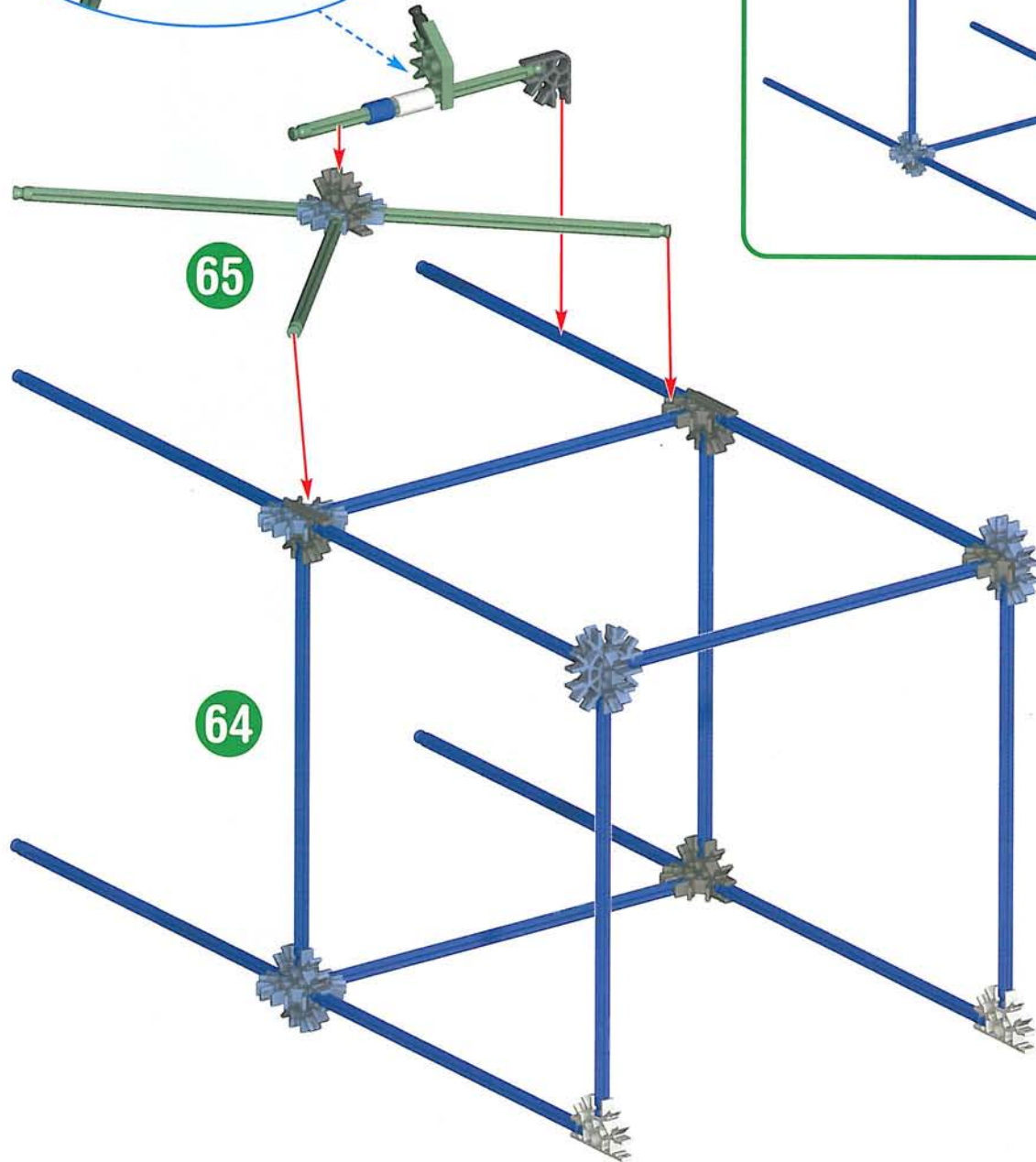
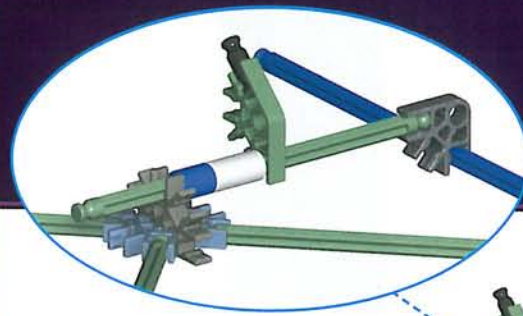
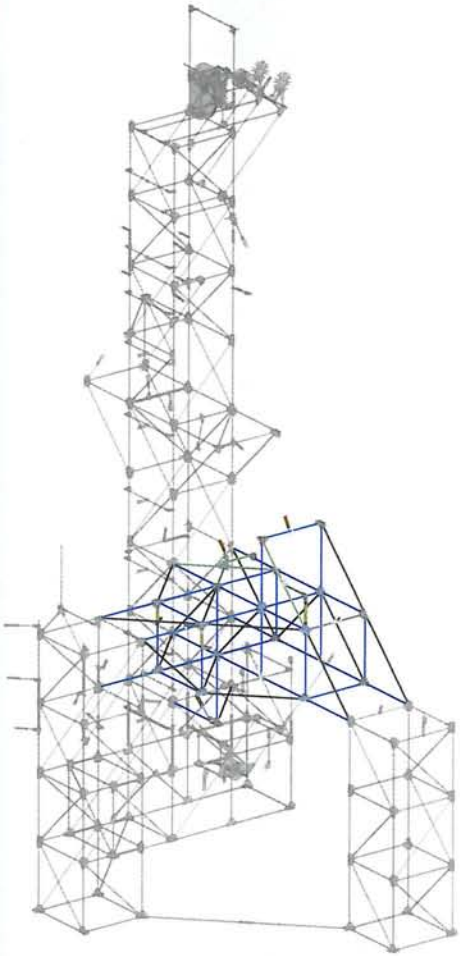

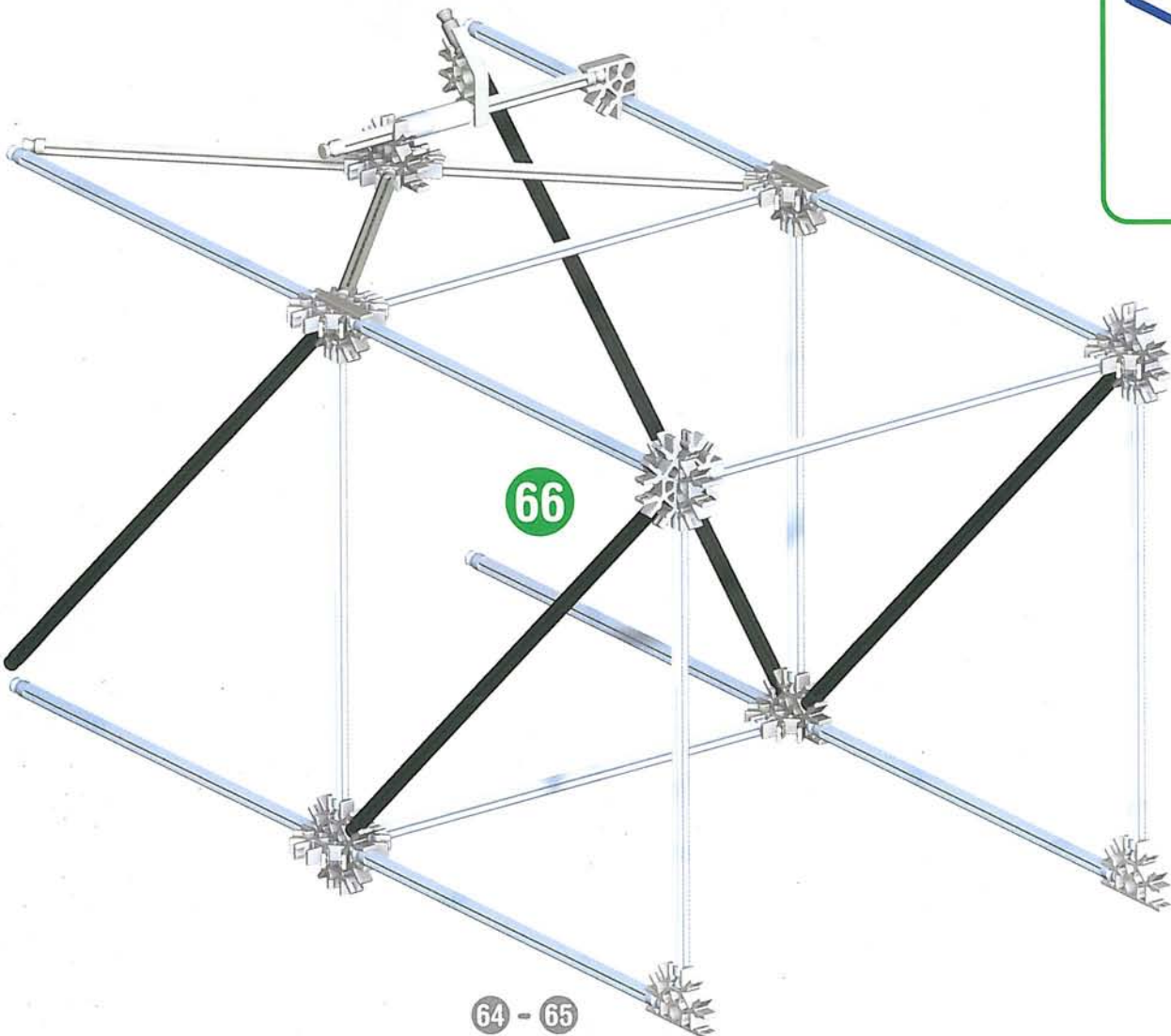
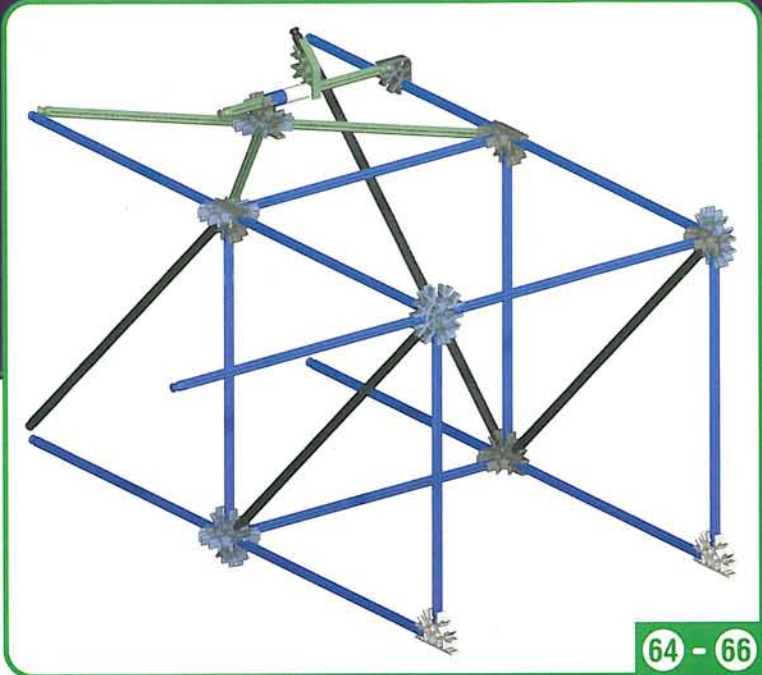

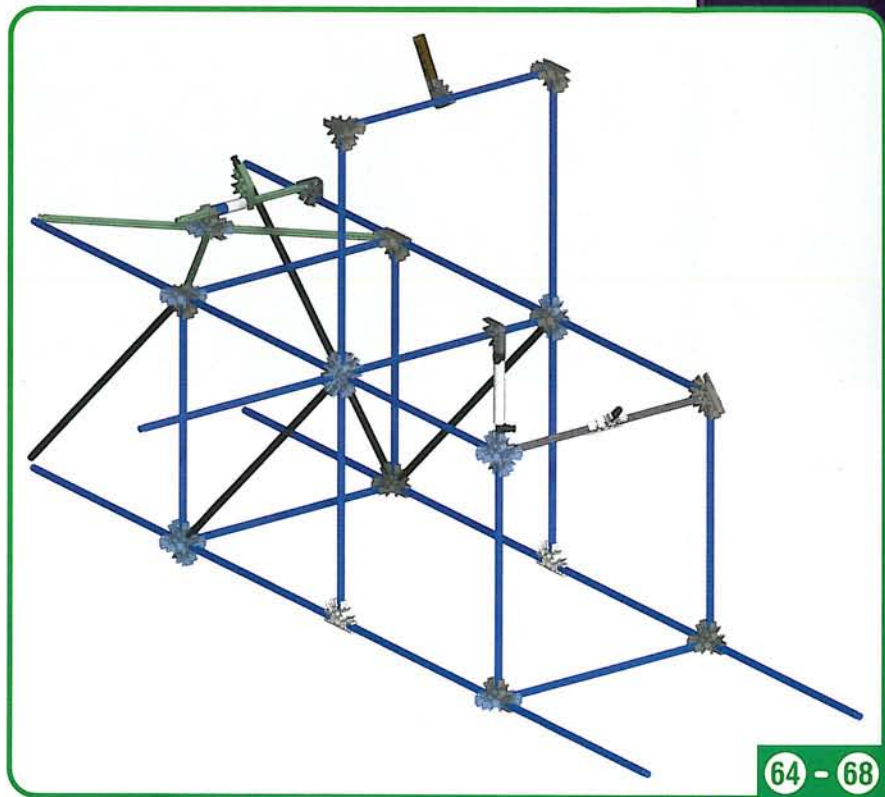
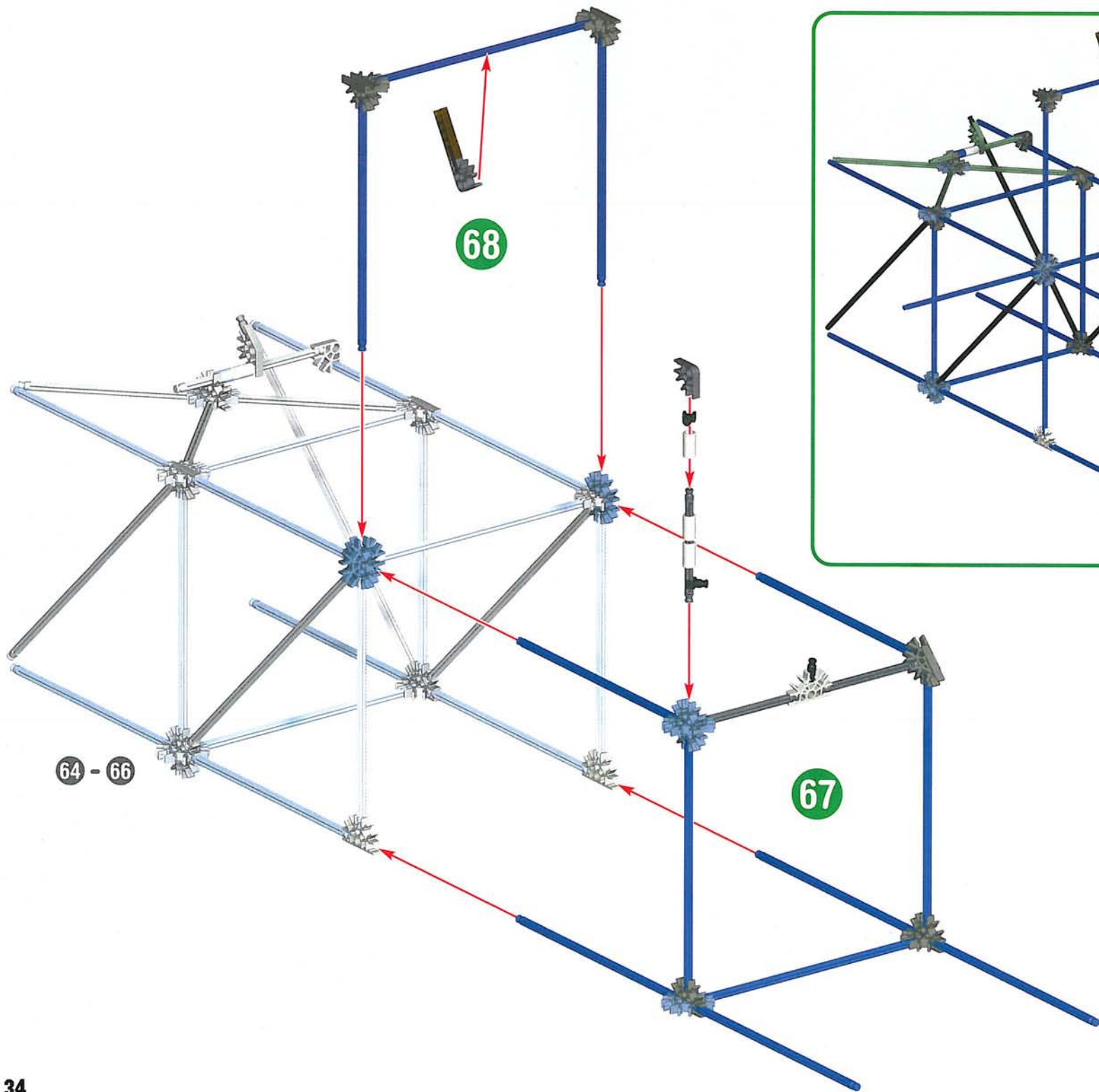

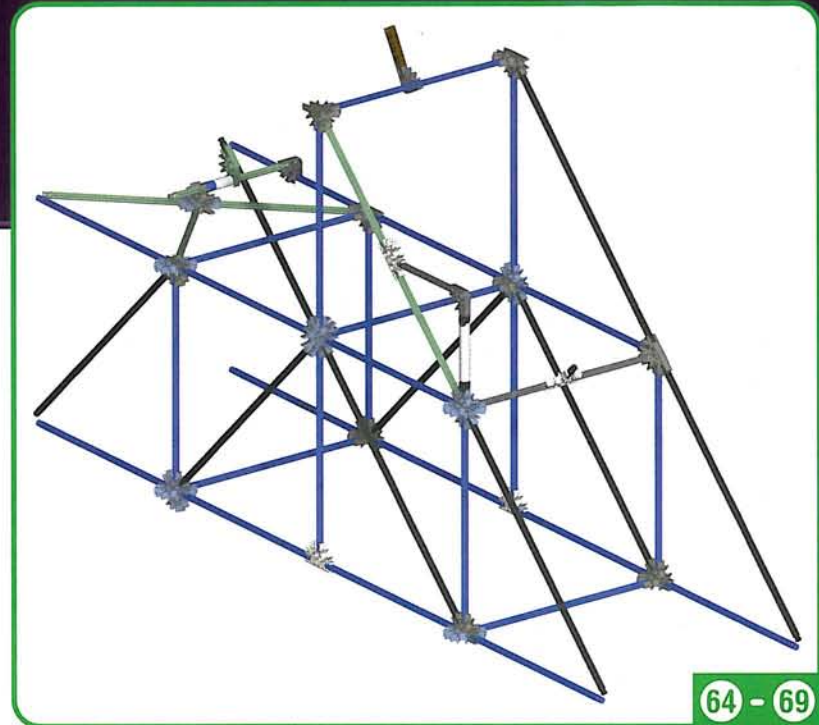

64 - 69

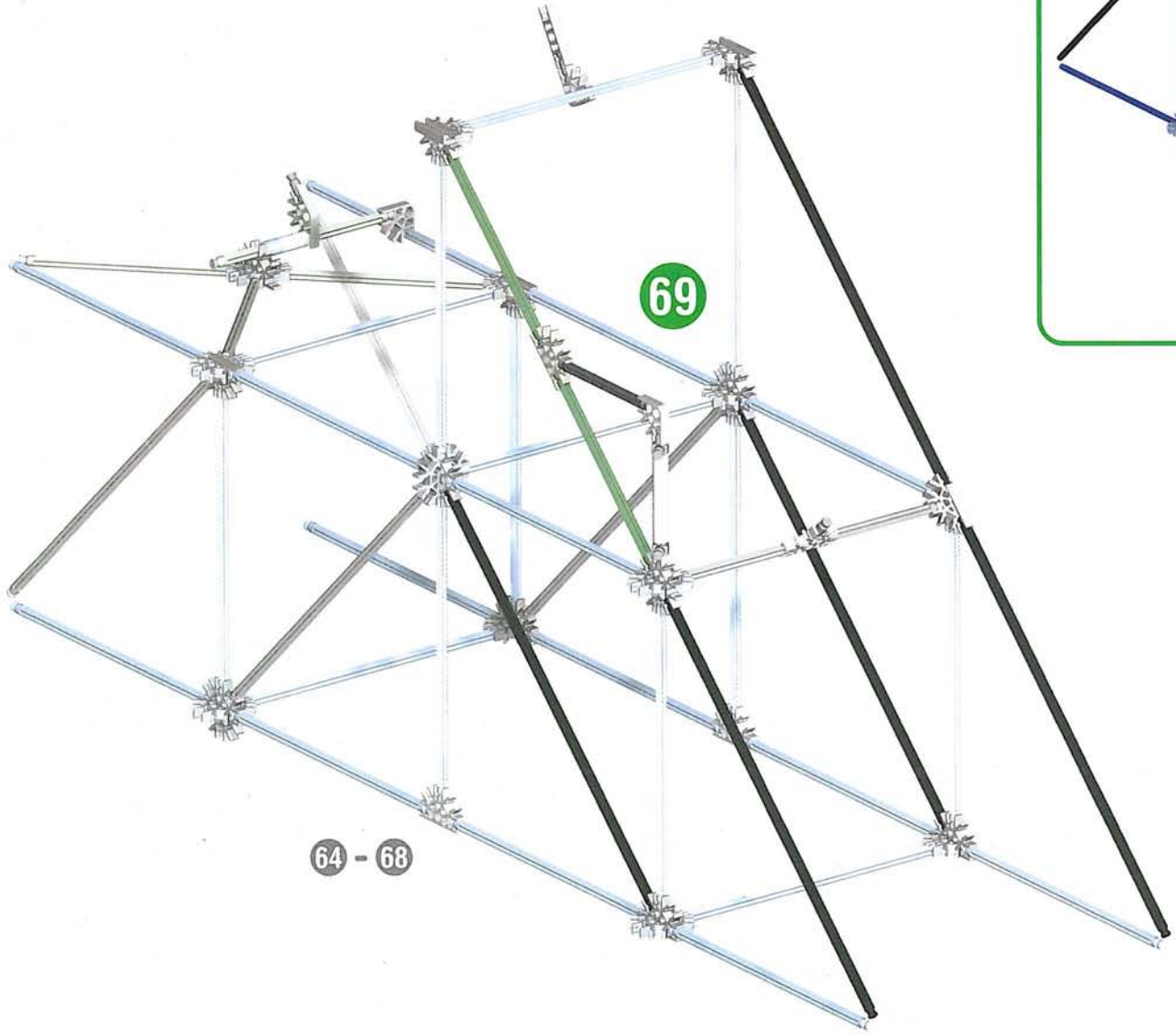

64 - 68

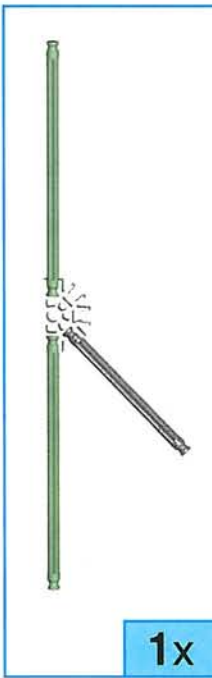

1x



5x

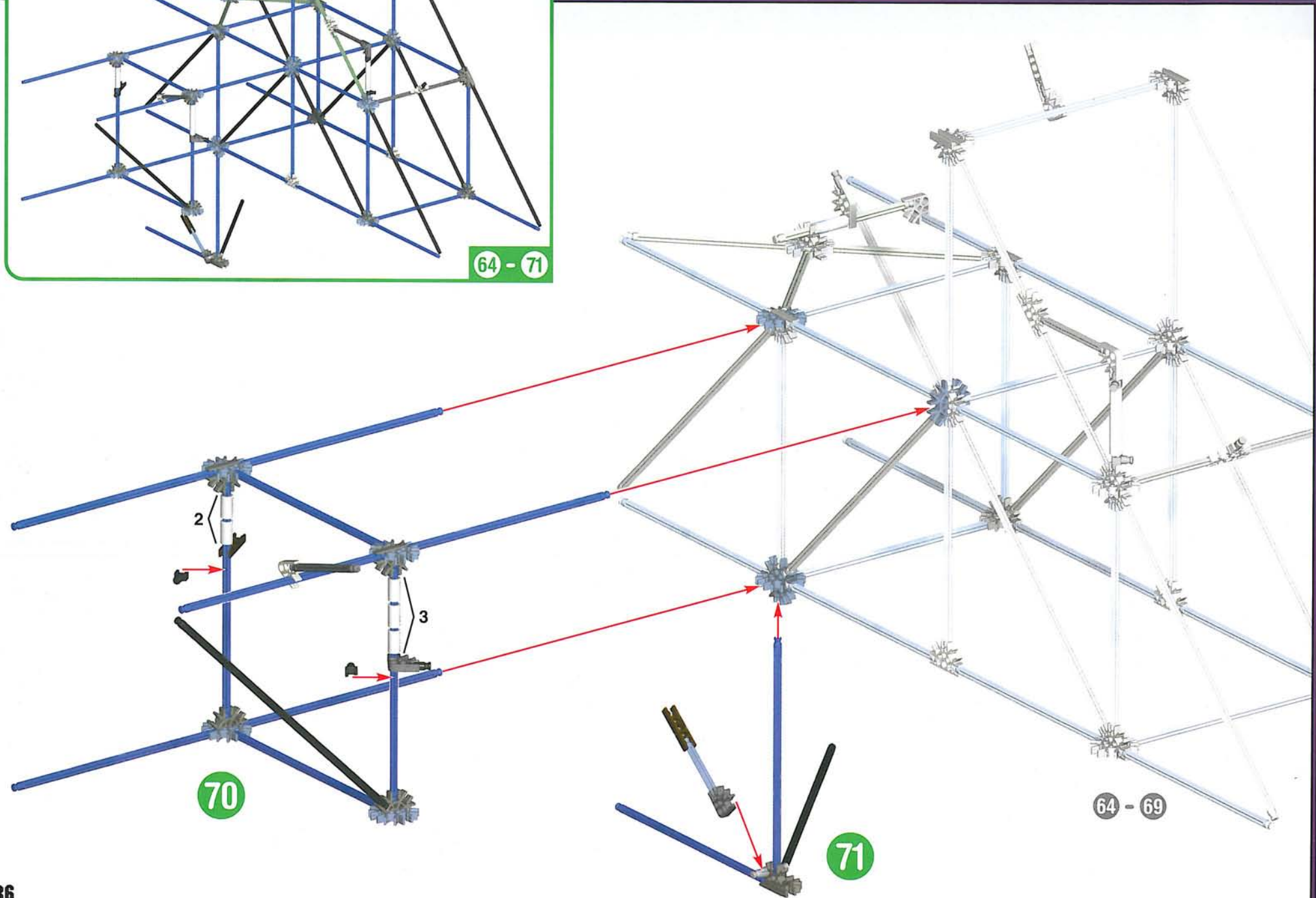
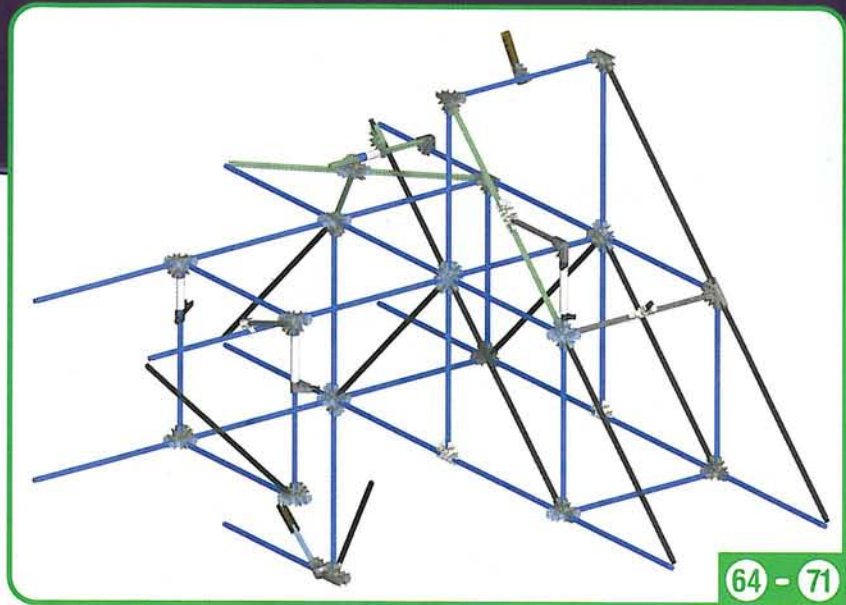

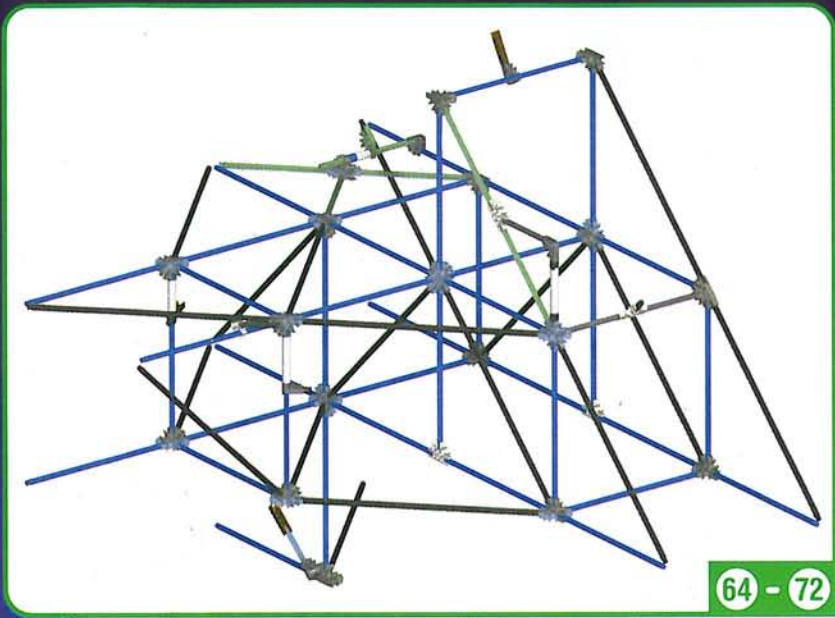

64 - 72

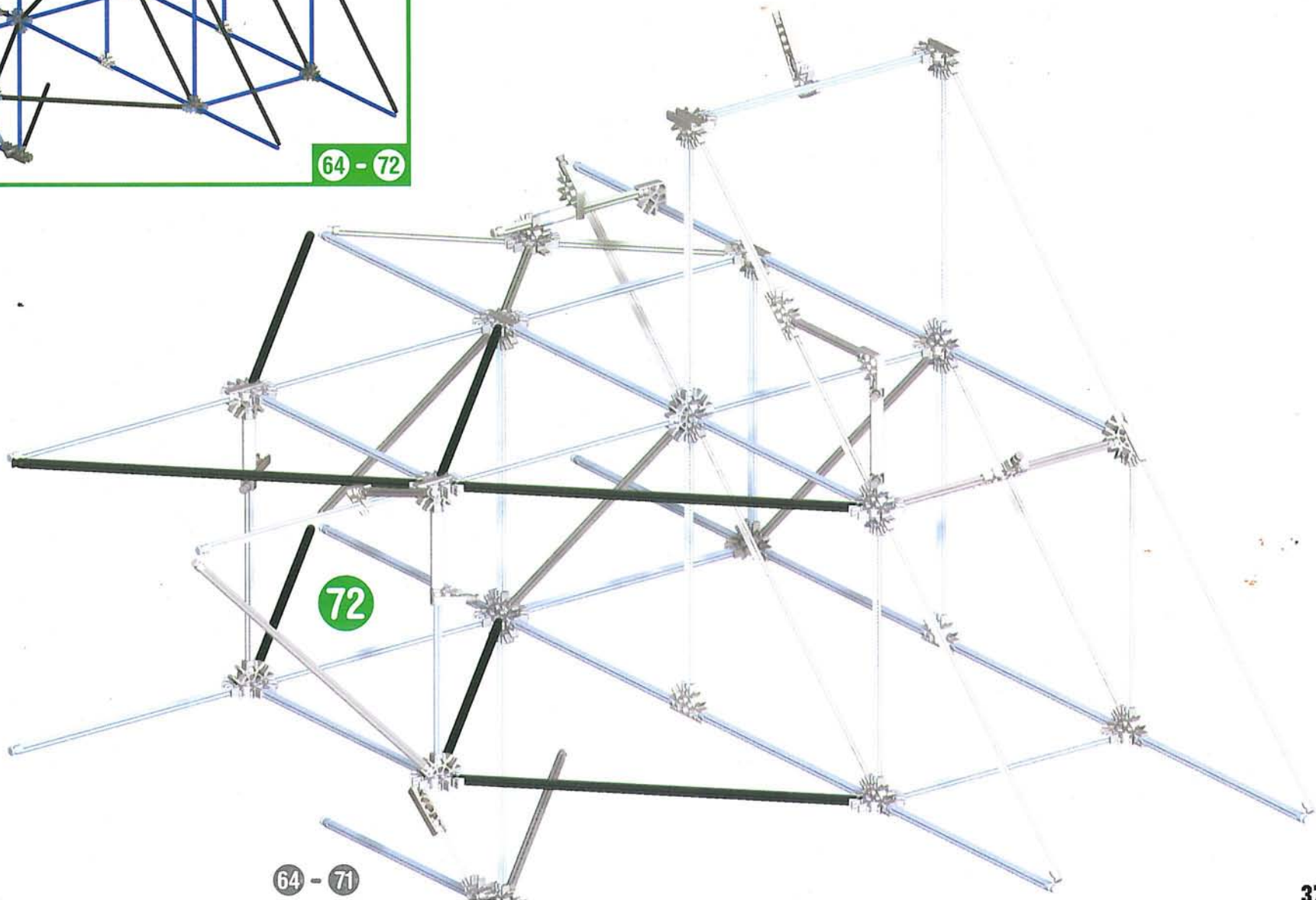

72

64 - 71



7x

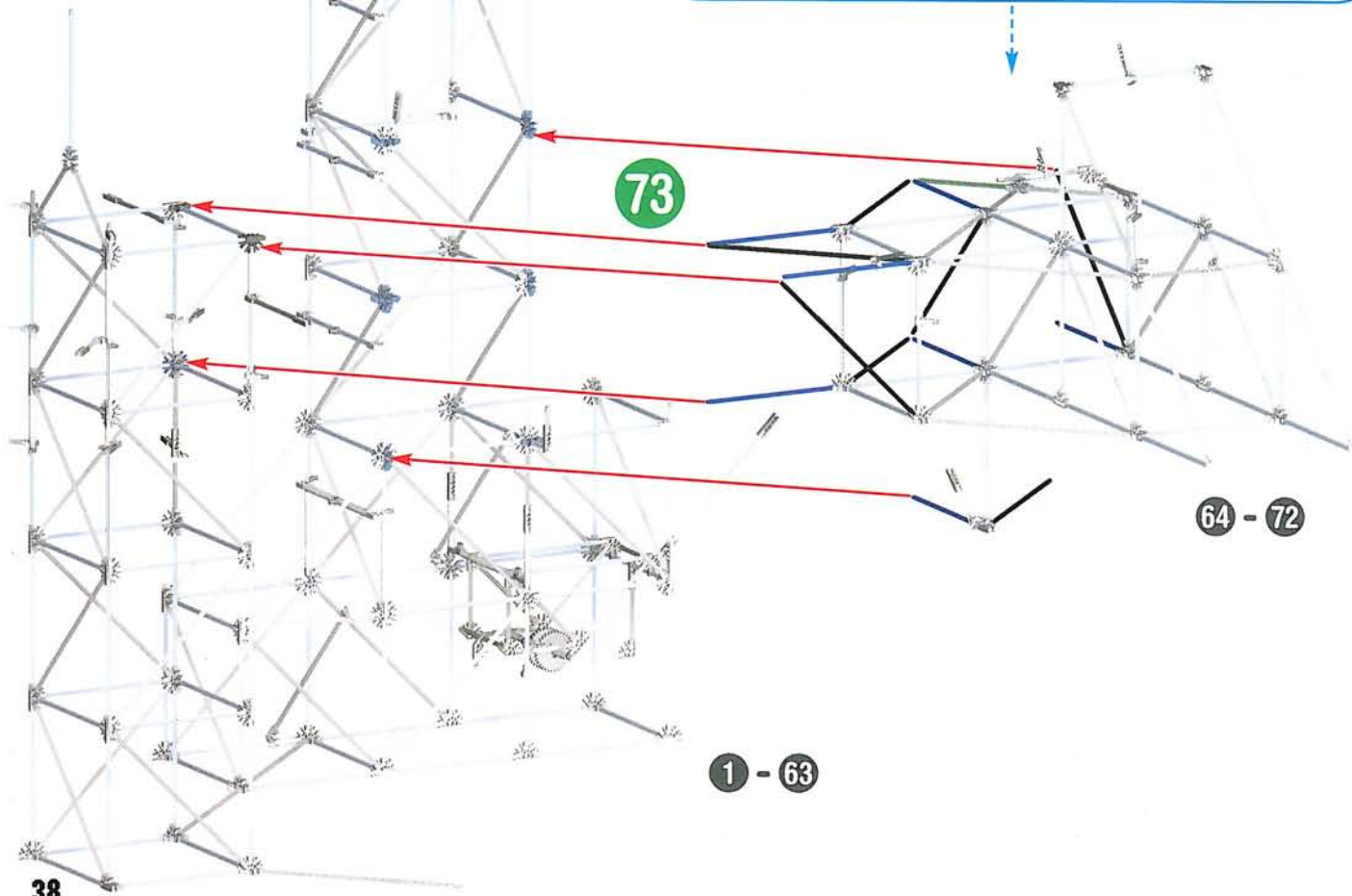
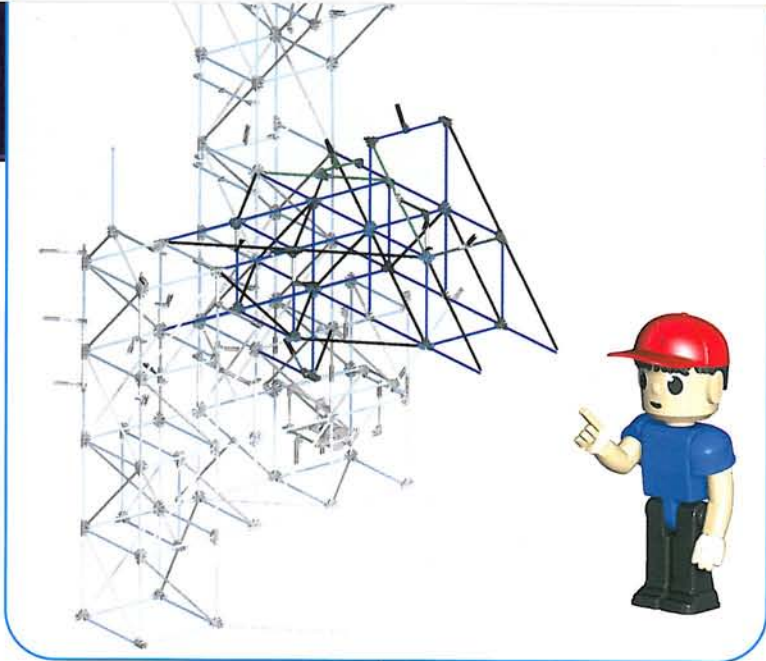
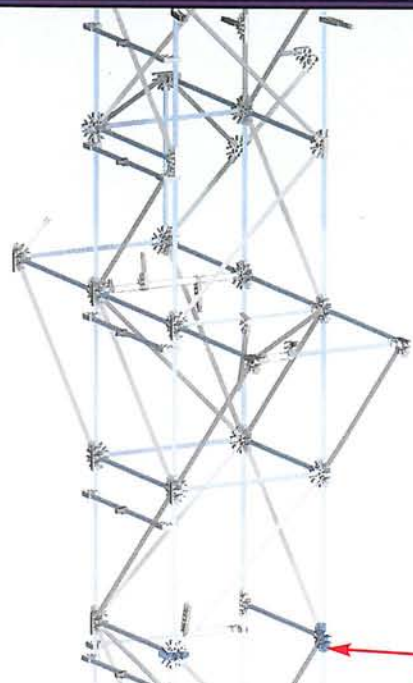

73

64 - 72

1 - 63

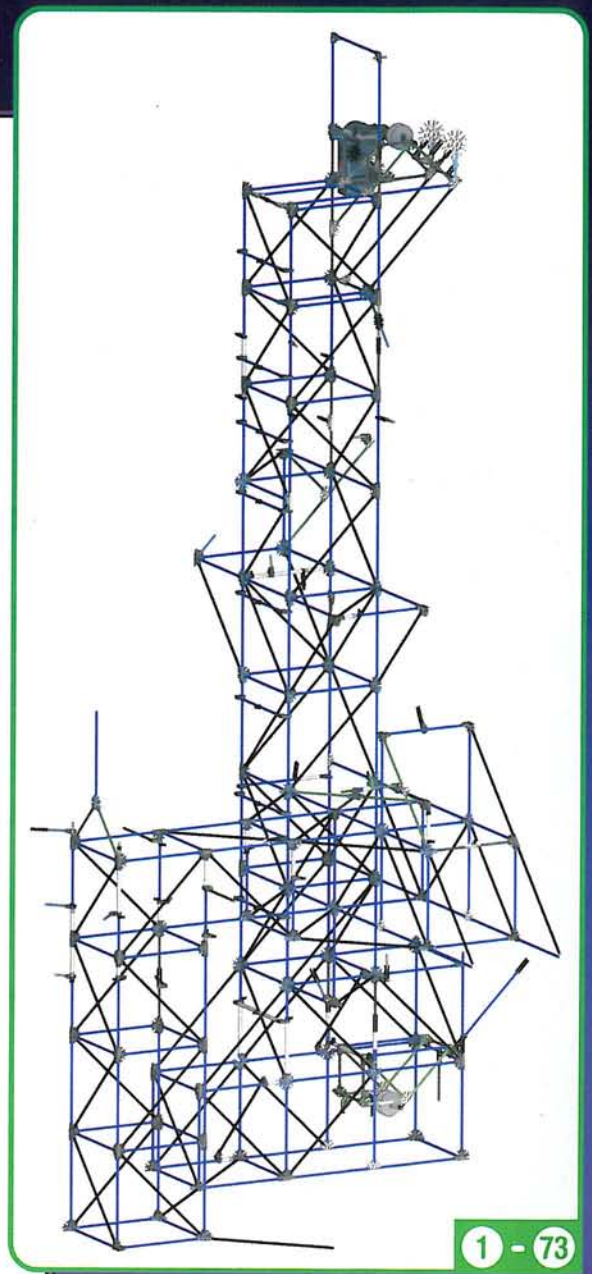

1 - 73

VERTICAL VENGEANCE: (ADVANCED BUILD)

TOWER 3

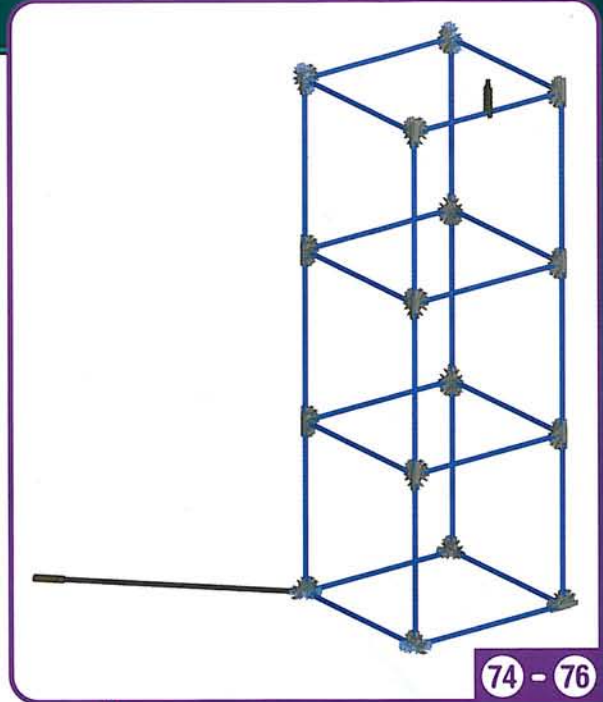
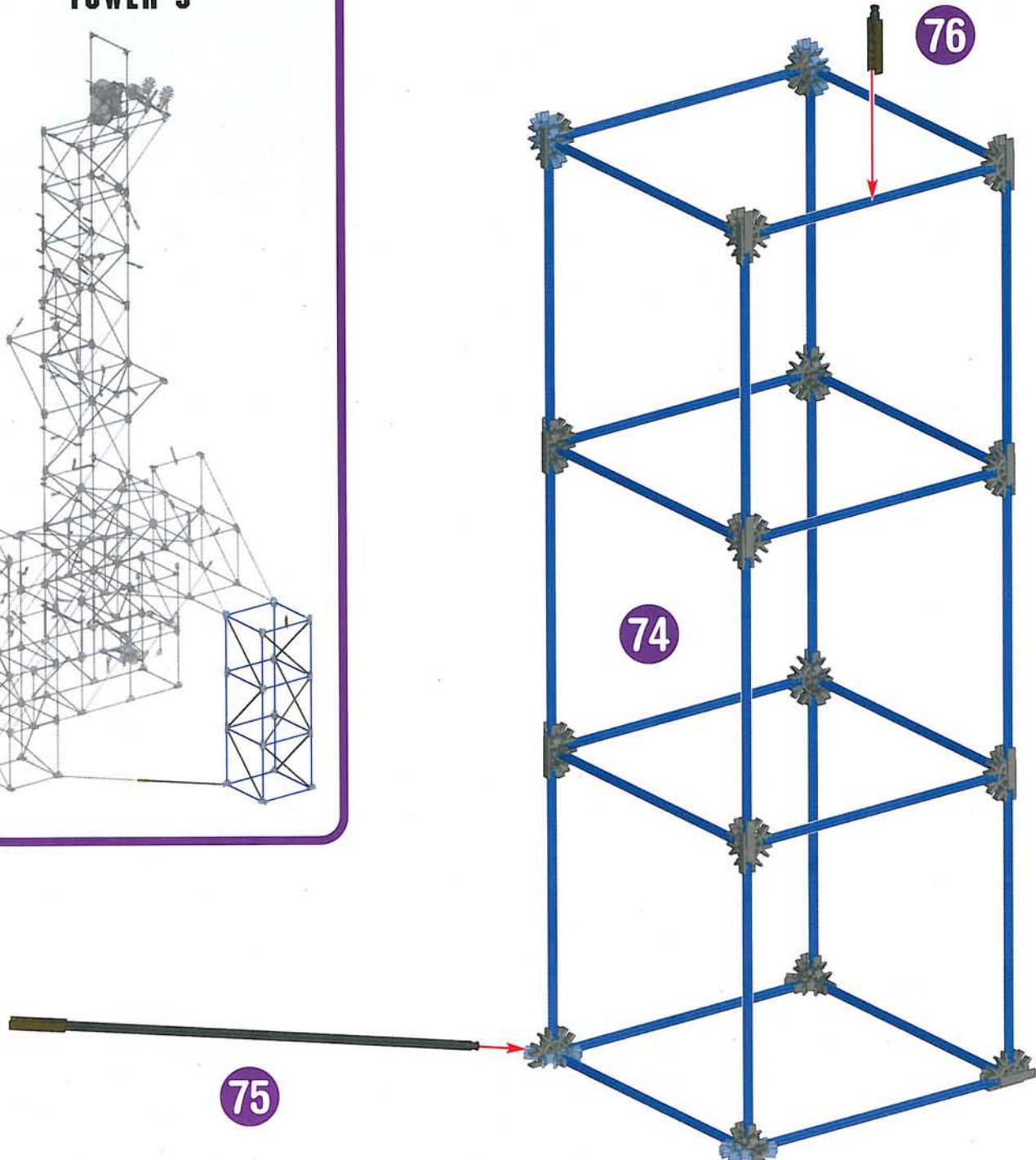
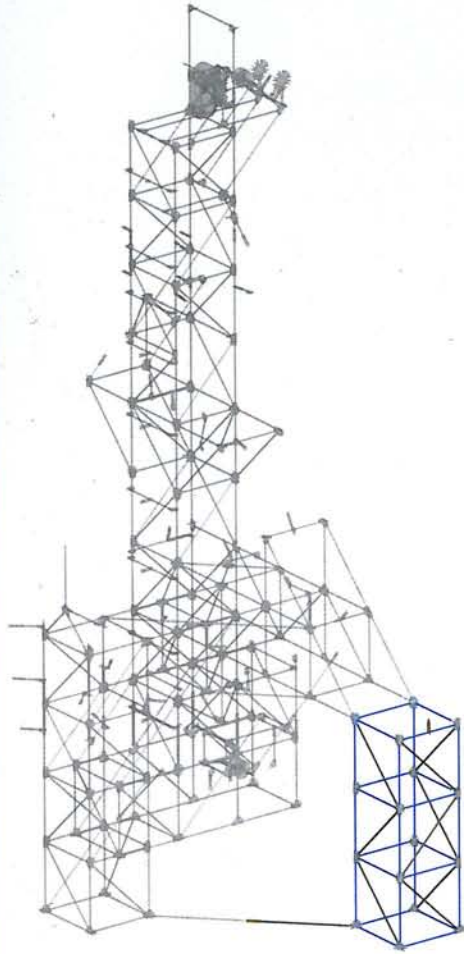

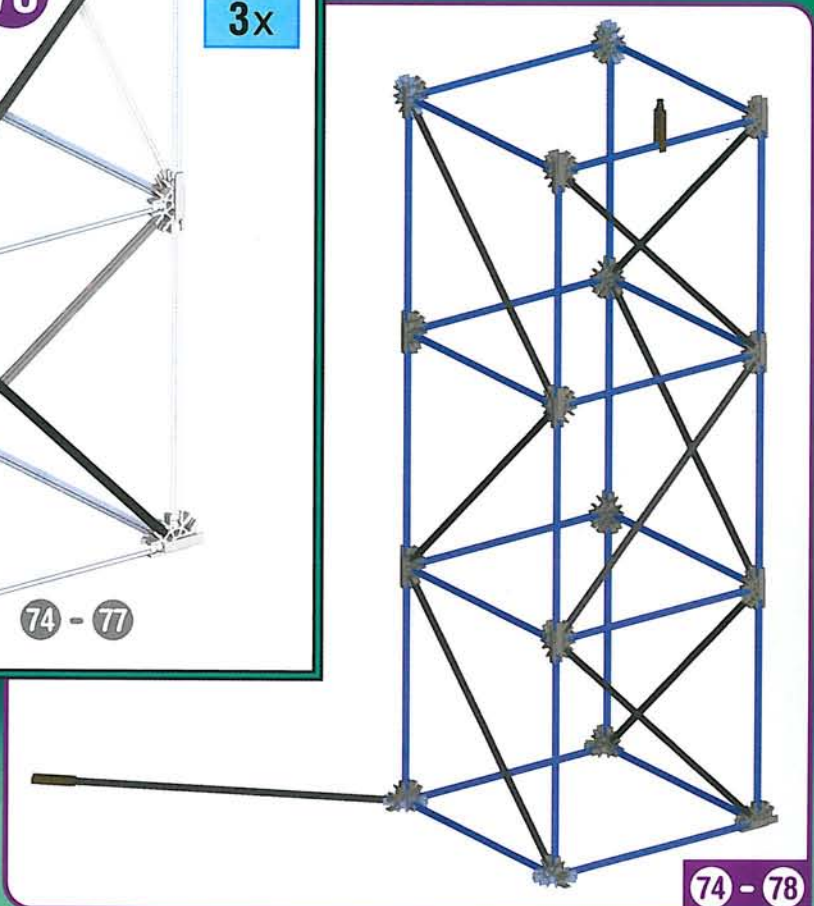
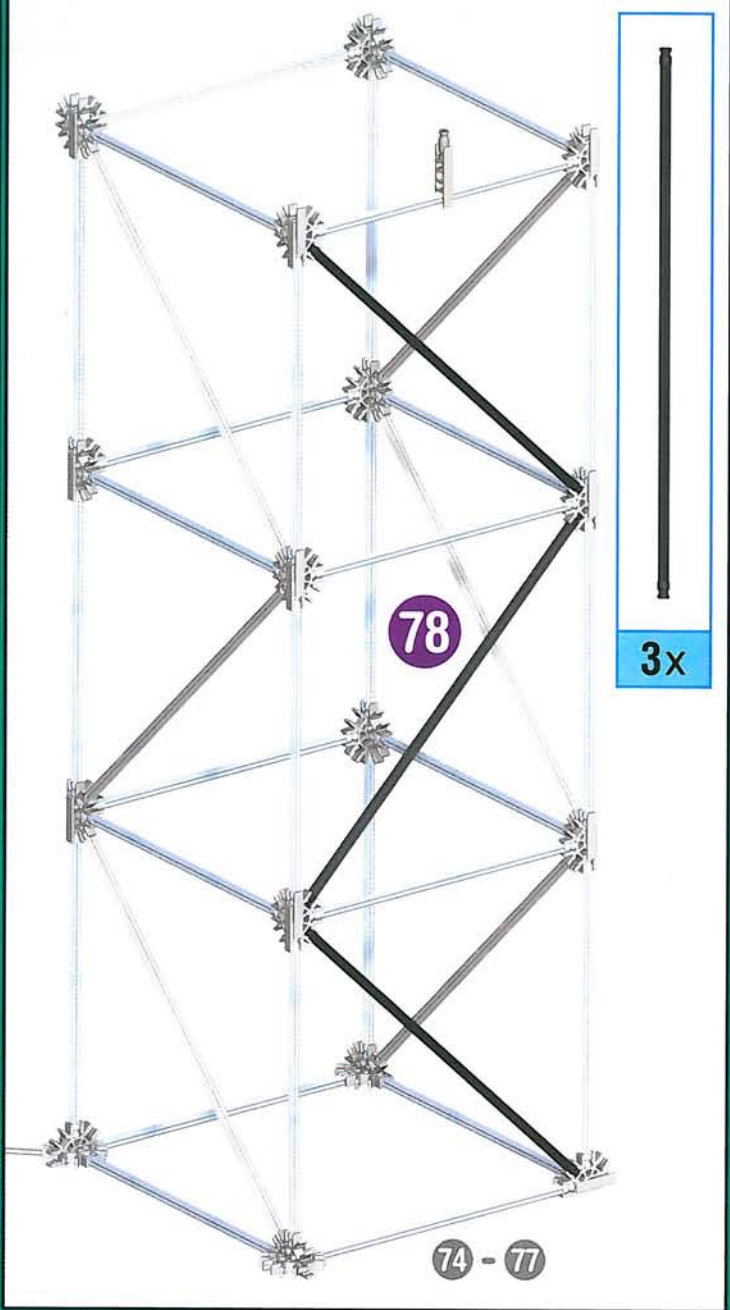
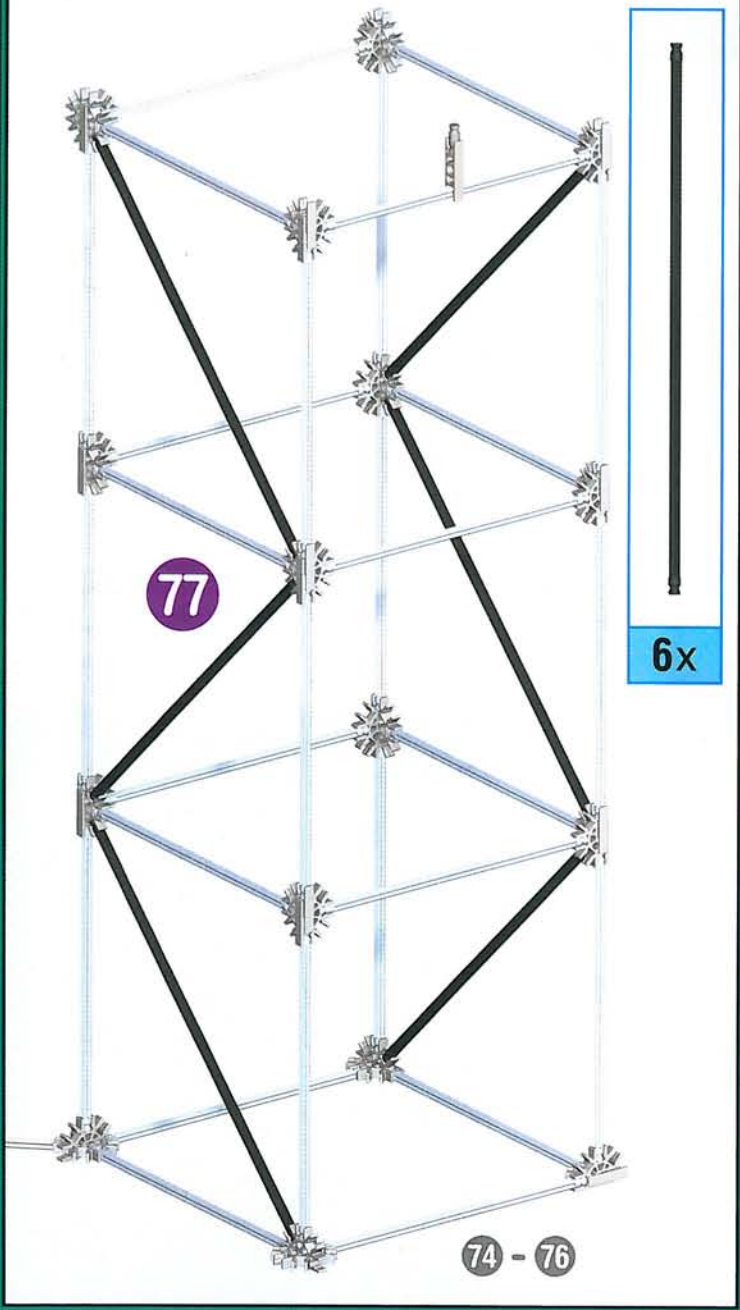

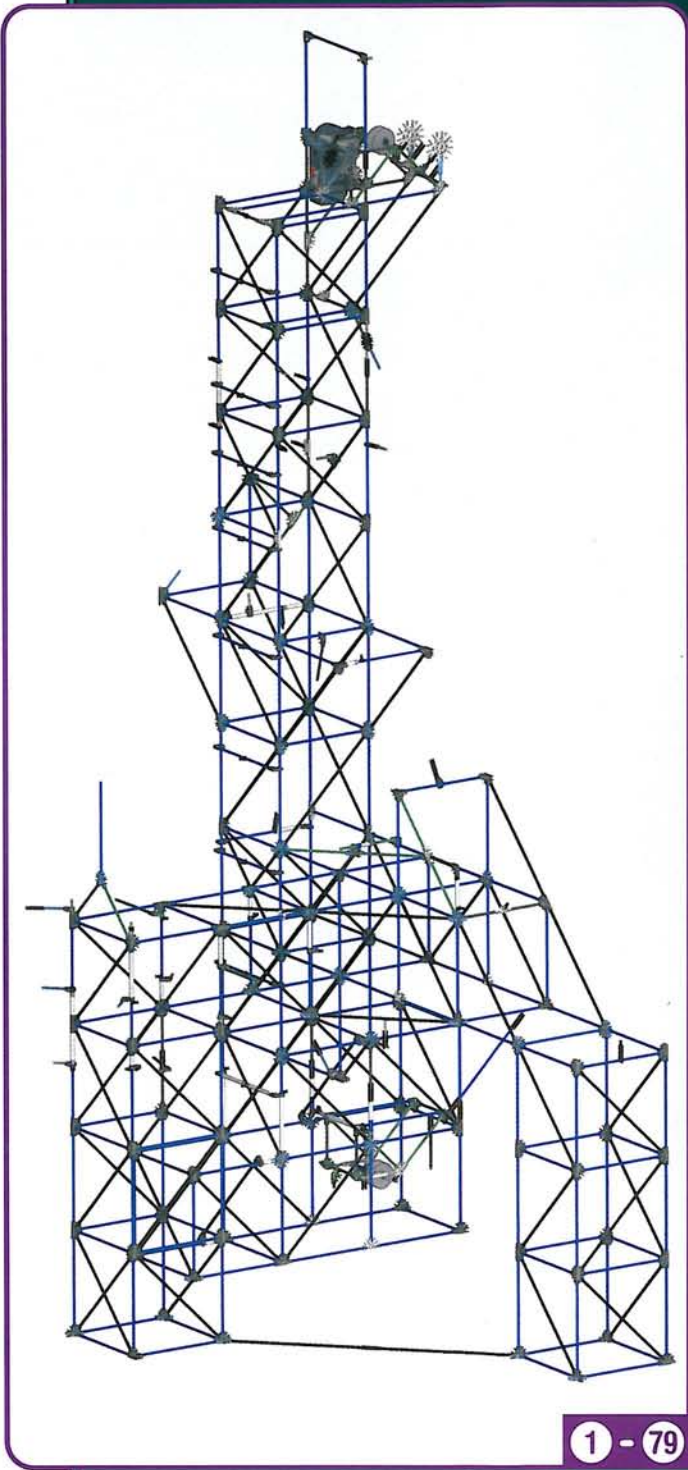
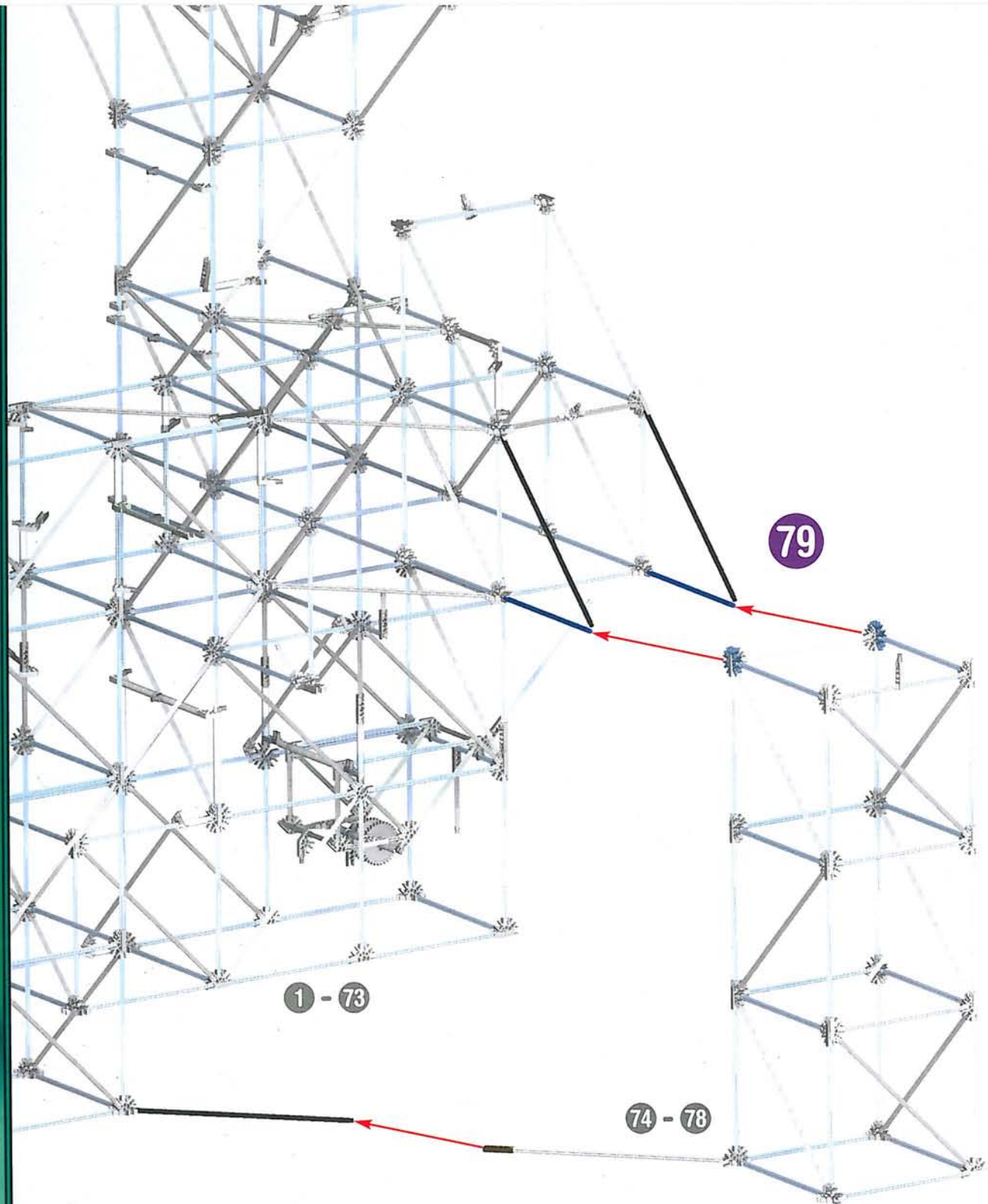

Track Tips:

1. There is a top and bottom side to the Track. Always connect the Track top side to top side throughout the build.

2. To connect the Track pieces, line up the metal pins and push until they are tight.

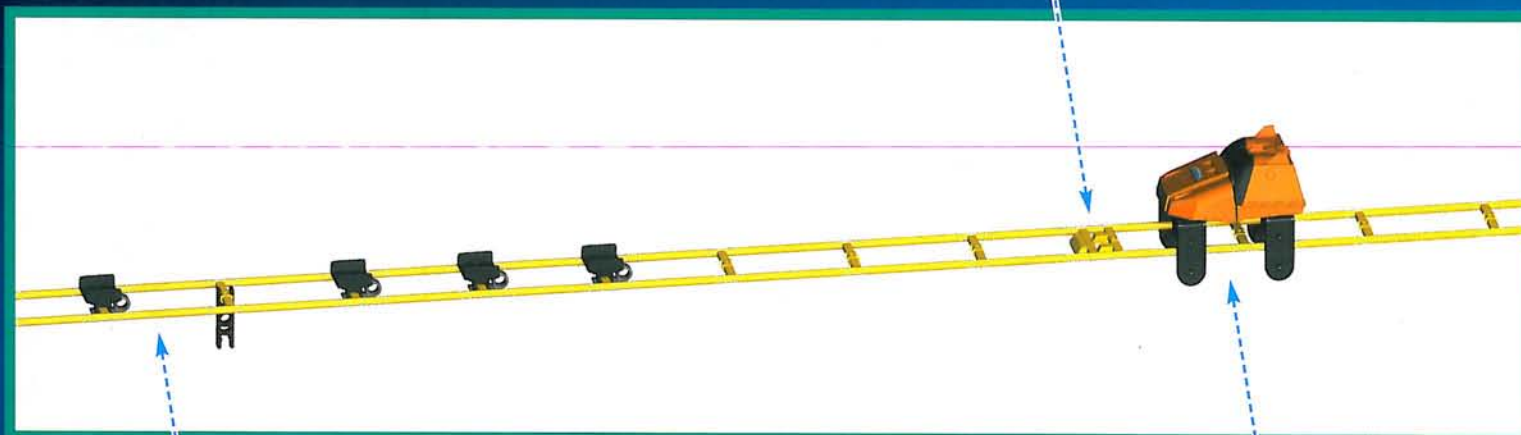
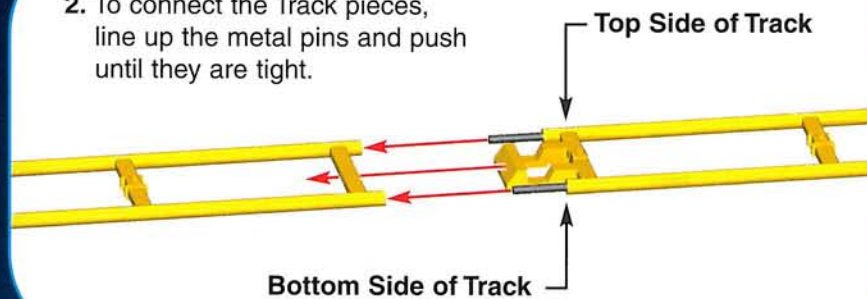

3. Attach the black Chain Guides to the top of the Track and attach the Connectors to the bottom of the Track exactly as shown. Push the Connectors on firmly until they "click".

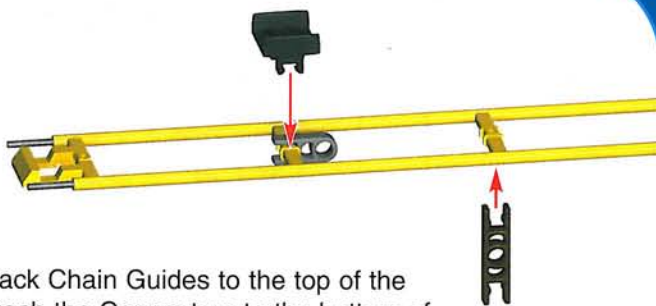

4. The Cars run on the top of the Track. To attach the Cars, slide them onto an open end of the Track.

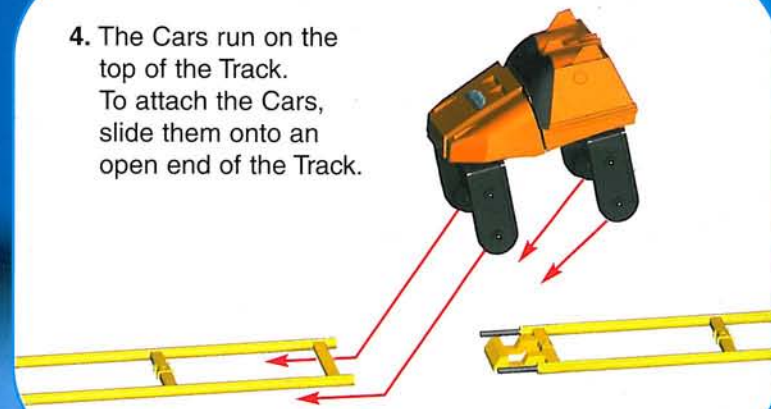

VERTICAL VENGEANCE: (ADVANCED BUILD)

ATTACH TRACK

Front View

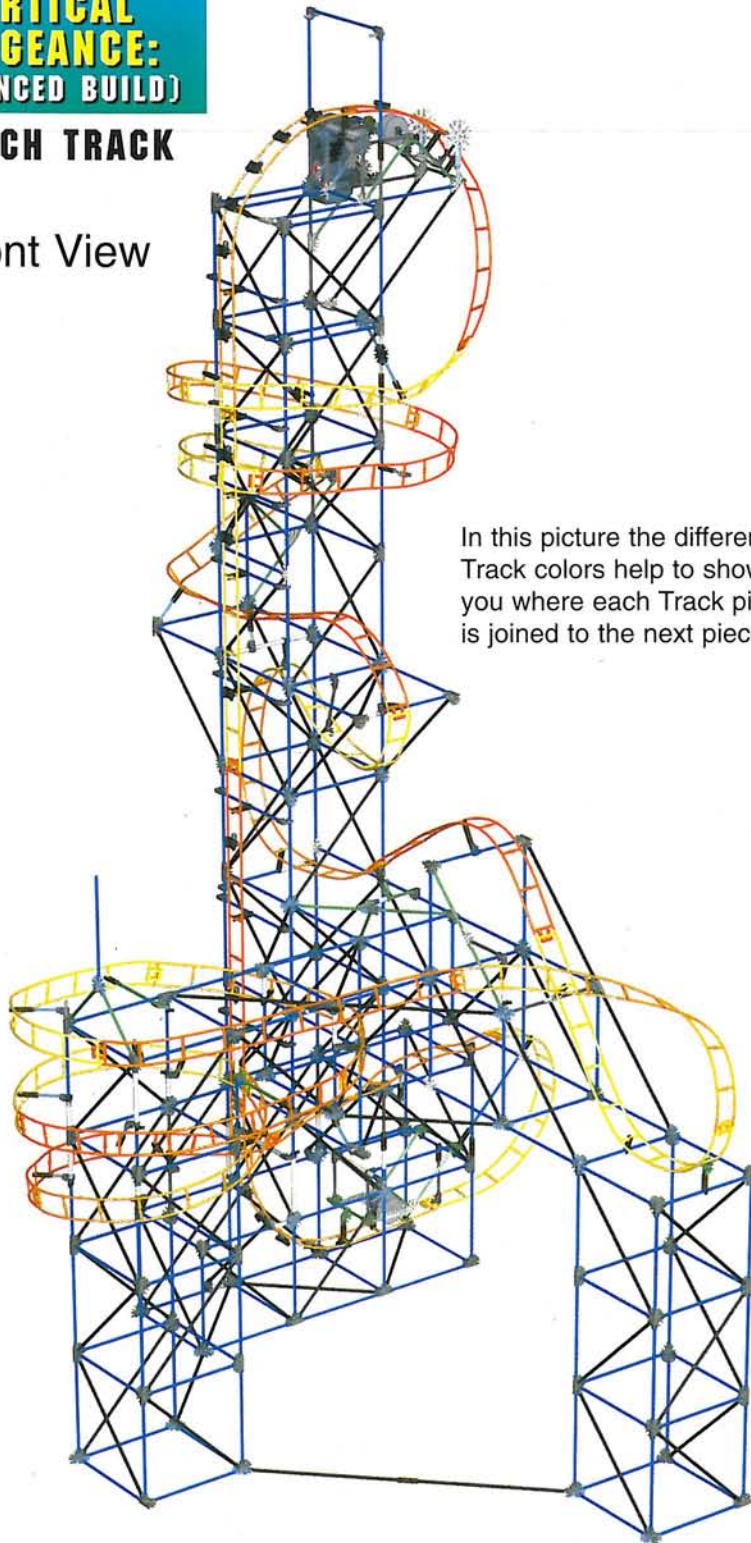

In this picture the different Track colors help to show you where each Track piece is joined to the next piece.

F Conseils pour le circuit :

1. Il y a un côté supérieur et un côté inférieur pour le circuit. Connecte toujours le côté supérieur du circuit contre le côté supérieur tout au long de la construction.
2. Les voitures roulent sur la partie supérieure du circuit. Pour fixer les voitures, pince légèrement le circuit et fixe les roues dessus.
3. Fixe les guides de chaîne à la partie supérieure du circuit. Fixe les connecteurs à la partie inférieure du circuit exactement comme l'indique le schéma. Pousse bien les connecteurs jusqu'à ce qu'ils « cliquent ».
4. Pour connecter les tronçons du circuit, aligne les chevilles en métal et pousse jusqu'à ce qu'elles soient bien serrées.

E Consejos para armar las Pistas:

1. En la Pista hay un lado superior y un lado inferior. Al construir, conecta siempre la Pista de lado superior a lado superior.
2. Los coches corren en el lado superior de la Pista. Para sujetar los Coches, aprieta la Pista levemente y engancha las ruedas en la Pista.
3. Sujeta las Guías de Cadena al lado superior de la Pista. Sujeta los Conectores en el lado inferior de la Pista, exactamente como se muestra. Empuja los Conectores hacia adentro hasta que oigas un « clic ».
4. Para conectar las piezas de la Pista, pon en línea los broches de metal y empujalos hasta que queden apretados.

D Tipps für die Schienen:

1. Jedes Schienenstück hat eine Ober- und eine Unterseite. Die einzelnen Schienenstücke müssen immer mit der Oberseite nach oben zeigen, wenn sie miteinander verbunden werden.
2. Die Wagen fahren auf der Oberseite der Schienen. Die Wagen werden aufgesetzt, indem die Schienen leicht zusammengedrückt und die Räder dann in die Schiene eingehängt werden.
3. Befestige die Kettenführungen auf der Oberseite der Schienen. Befestige die Verbindungsstücke an der Unterseite der Schienenstücke, und zwar genau wie in der Abbildung gezeigt. Drücke die Verbindungsstücke richtig fest, bis sie mit einem „Klick“ einrasten.
4. Befestige die Schienenstücke miteinander, indem die Metallstifte der Schienenstücke aufeinander ausgerichtet sein. Drücke sie so fest, dass sie fest sitzen.

NL Spoortips:

1. Het spoor heeft een bovenkant en een onderkant. Maak steeds de bovenkant van het spoor vast aan de bovenkant tijdens de opbouw.
2. De wagens lopen op de bovenkant van het spoor. Om de wagens vast te maken, knijp lichtjes aan het spoor en haak de wielen op het spoor vast.
3. Maak de kettinggidsen vast bovenaan het spoor. Maak de koppelstukken vast aan de onderkant van het spoor precies zoals afgebeeld. Druk de koppelstukken goed erin tot ze “klikken”.
4. Om de spoorstukken aan mekaar vast te maken, stel de metalen pinnen op in een rij en druk ze in tot ze vast zitten.

I Punte delle rotaie:

1. Ci sono una parte superiore e una parte inferiore della rotaia. Collega sempre la rotaia parte superiore a parte superiore in tutta la costruzione.
2. Le carrozze scorrono sulla parte superiore della rotaia. Per attaccare le carrozze, premi la rotaia leggermente e aggancia le ruote sulla rotaia.
3. Attacca le guide a catena sulla parte superiore della rotaia. Collega i connettori sulla base della rotaia esattamente come illustrato. Premi i connettori saldamente fino a che si fissano con uno scatto.
4. Per collegare i pezzi della rotaia, allinea i perni di metallo e spingi fino a che si agganciano saldamente.

P Sugestões para a Pista:

1. A Pista tem uma face superior e uma face inferior. Liga sempre a face superior da Pista à face superior durante a montagem.
2. As Carruagens deslocam-se sobre a Pista. Para prenderes as Carruagens, comprime ligeiramente a Pista e encaixa as rodas na Pista.
3. Prende as Guias de Corrente ao topo da Pista. Liga os Conectores à base da Pista exactamente como demonstrado. Faz avançar os Conectores firmemente até “encaixarem” com um estalido.
4. Para ligares as peças da Pista, alinha os pinos metálicos e empurra-os até ficarem bem firmes.

Left Side View

In these pictures the different Track colors help to show you where each Track piece is joined to the next piece.

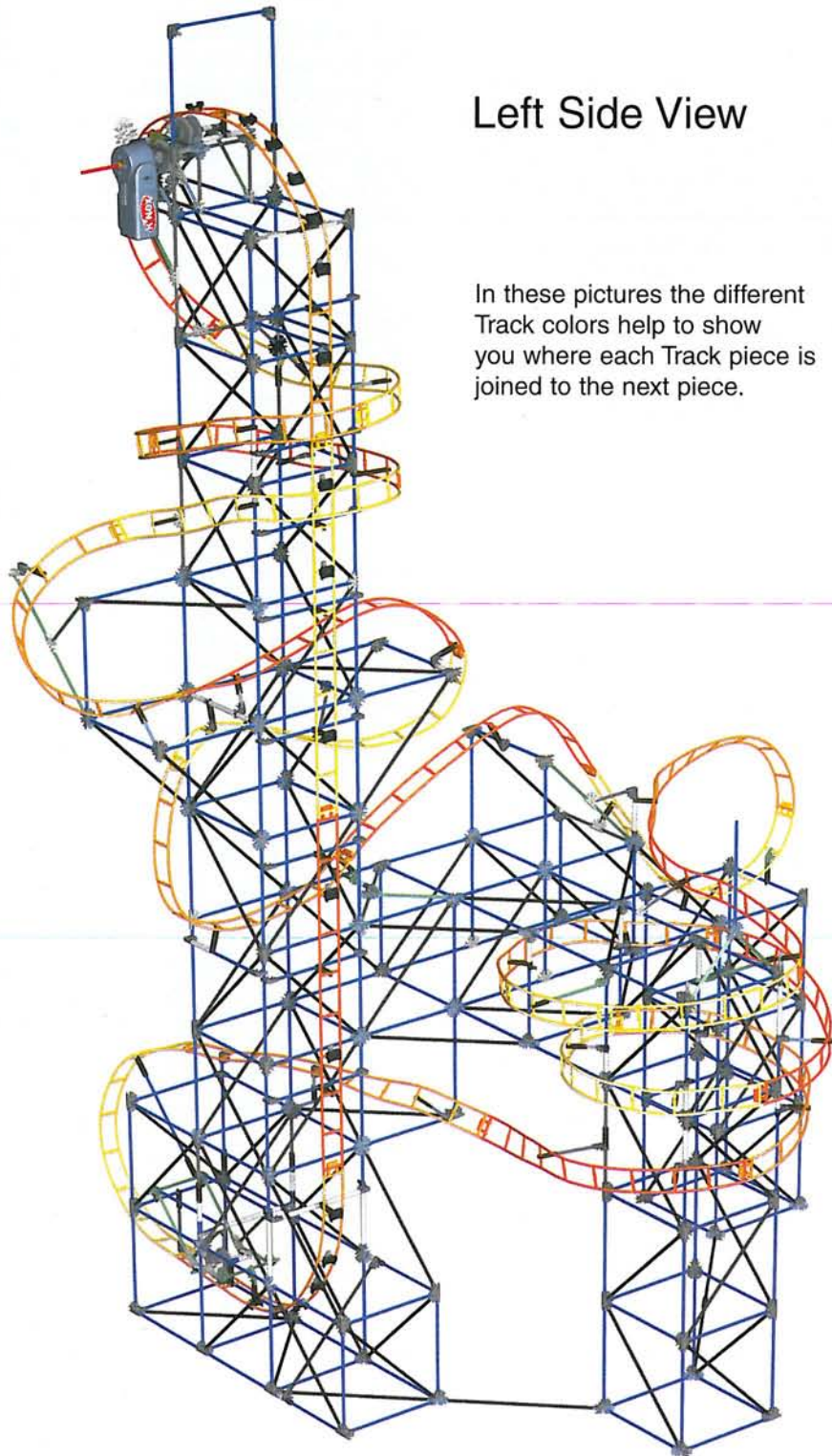

Right Side View

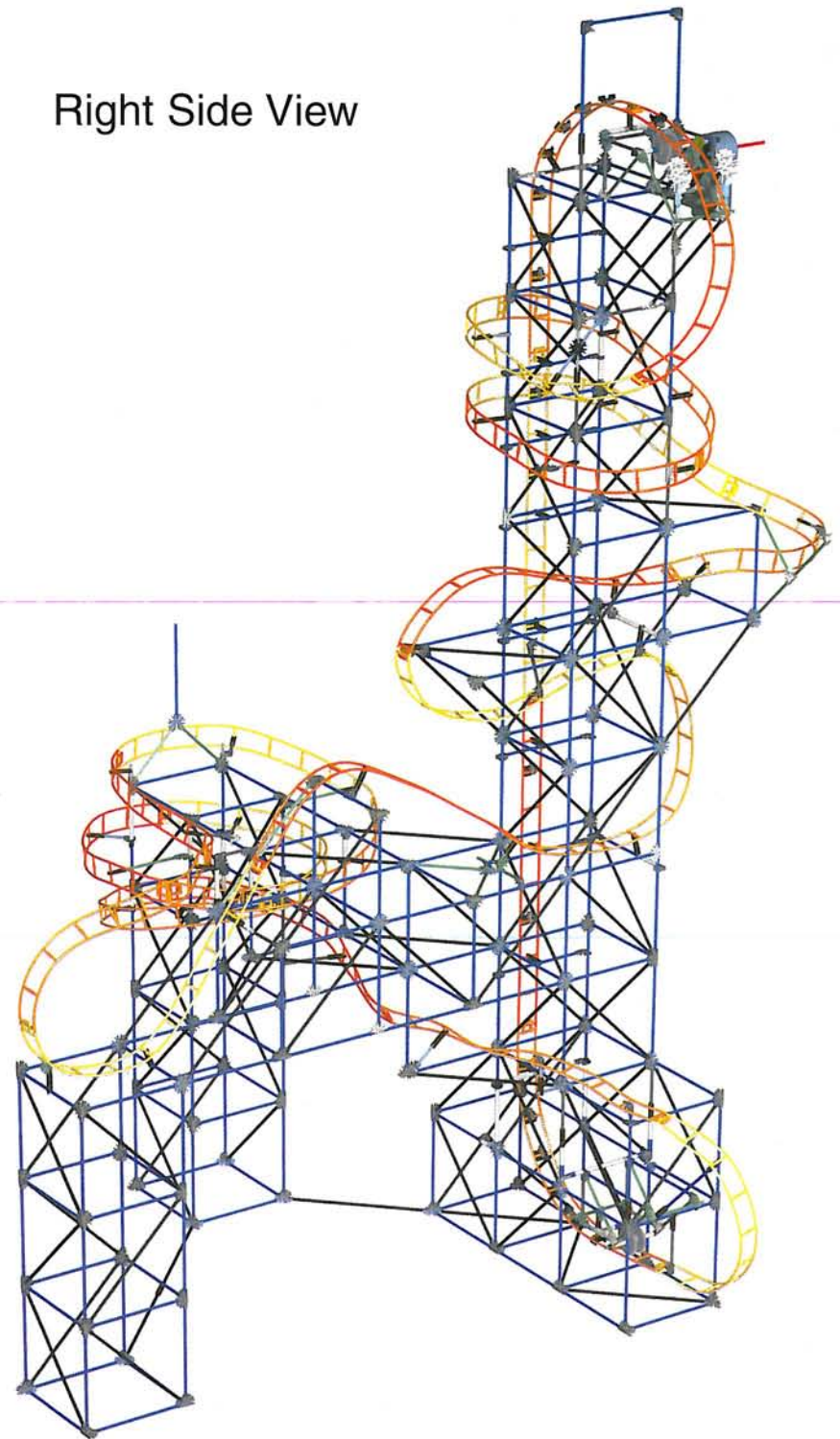

80

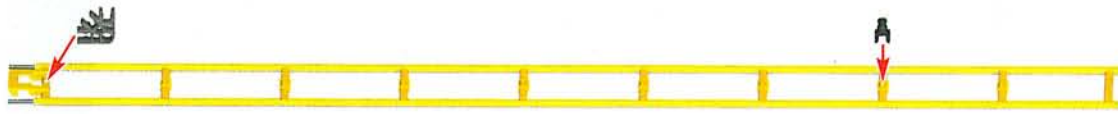

81

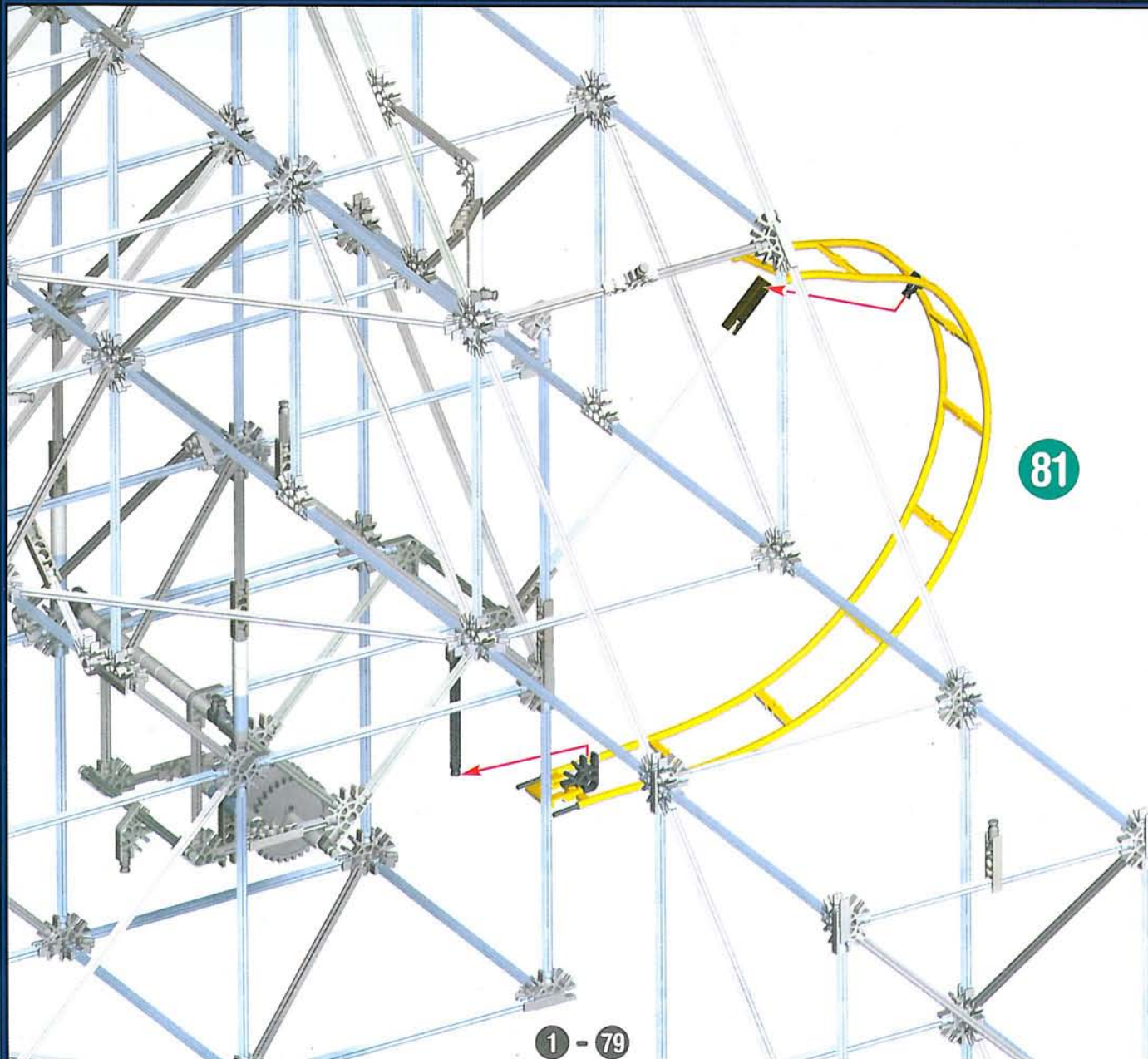

1 - 79

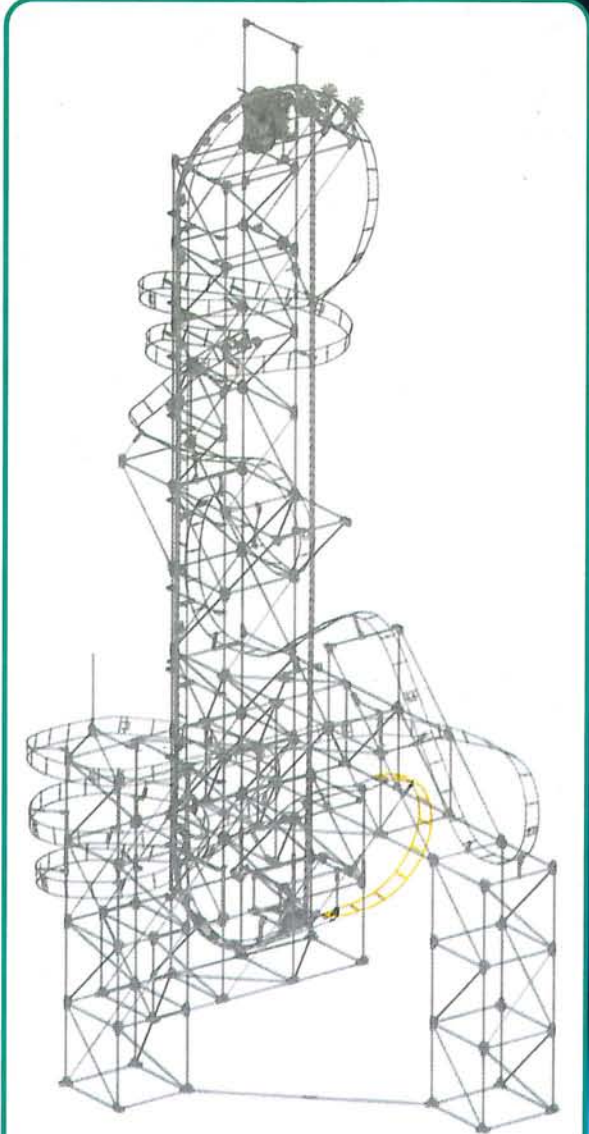

1 - 81

82

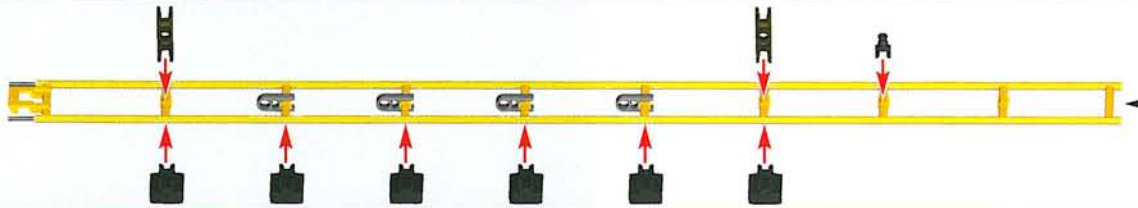

Always join this end of the Track to the previous Track piece first, then connect the rest of the Track to the tower.

83

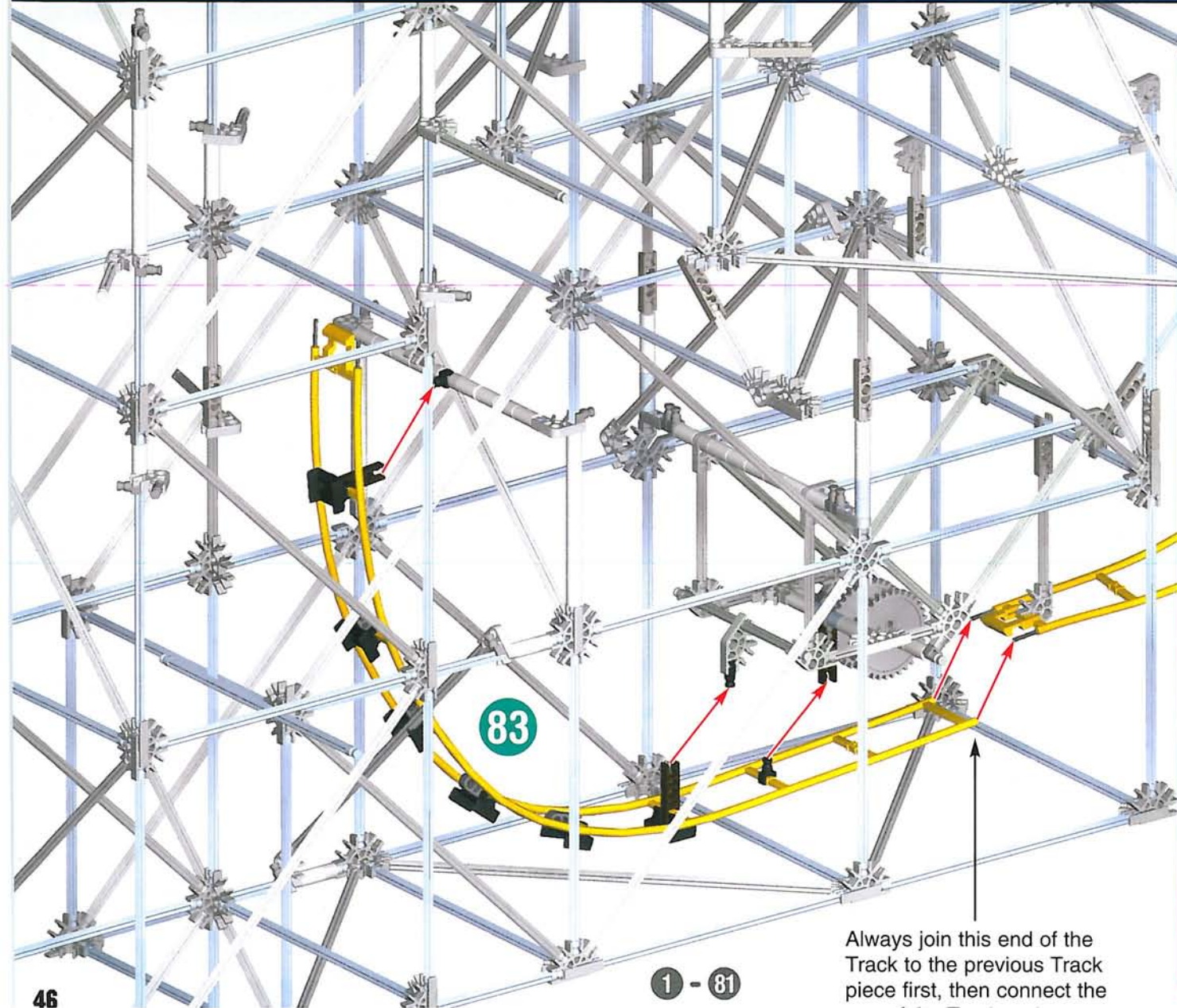

1 - 81

Always join this end of the Track to the previous Track piece first, then connect the

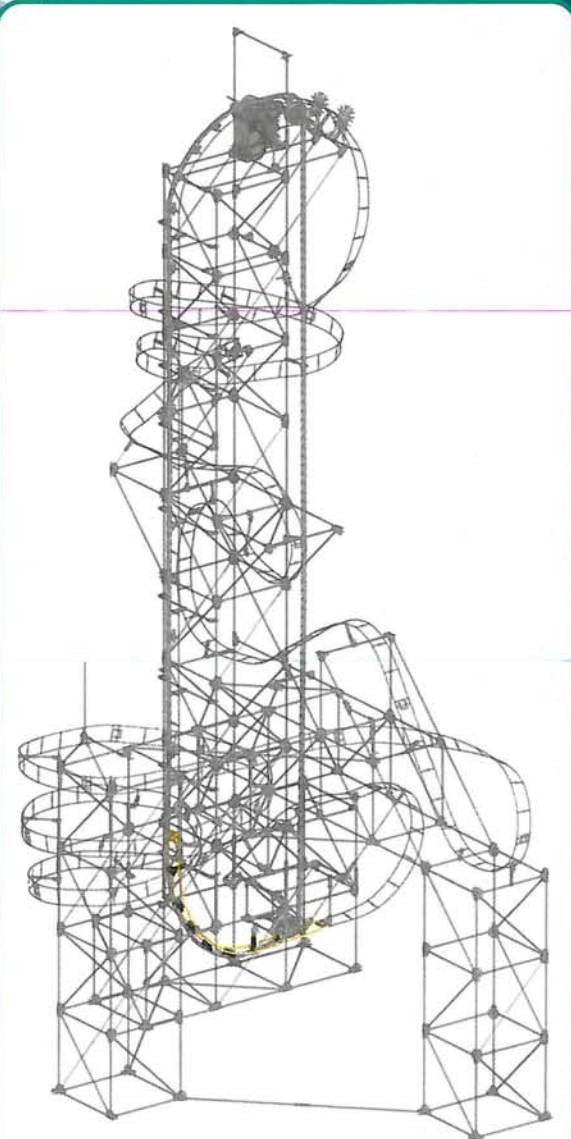

1 - 83

84

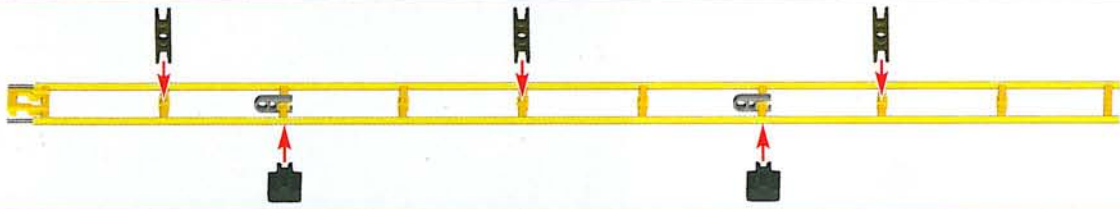

85

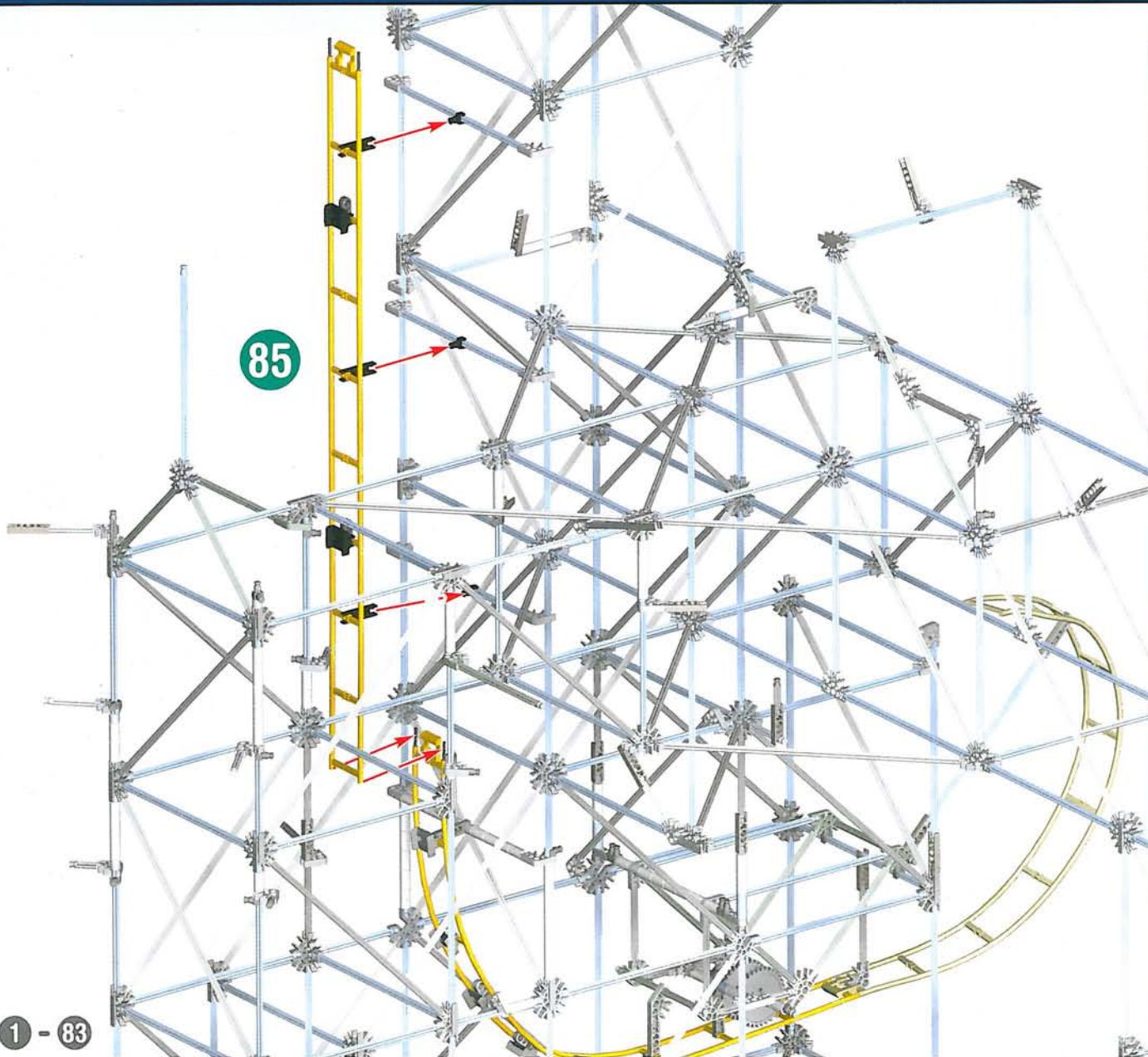

1 - 83

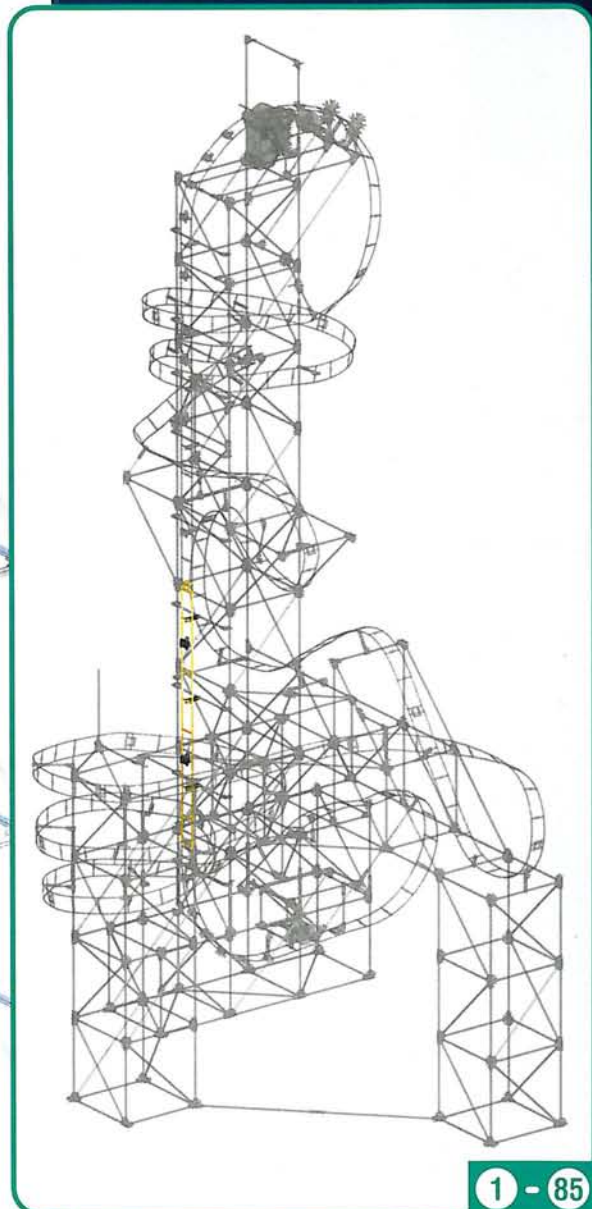

1 - 85

86

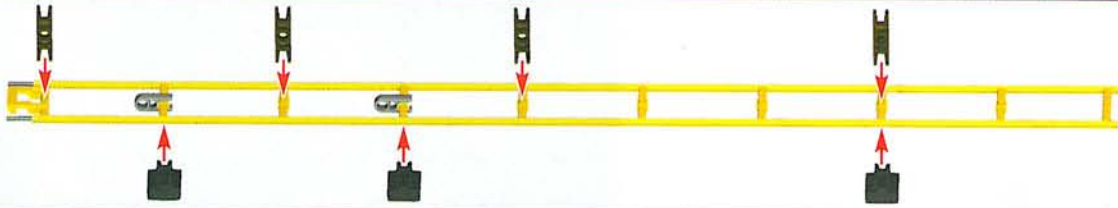

87

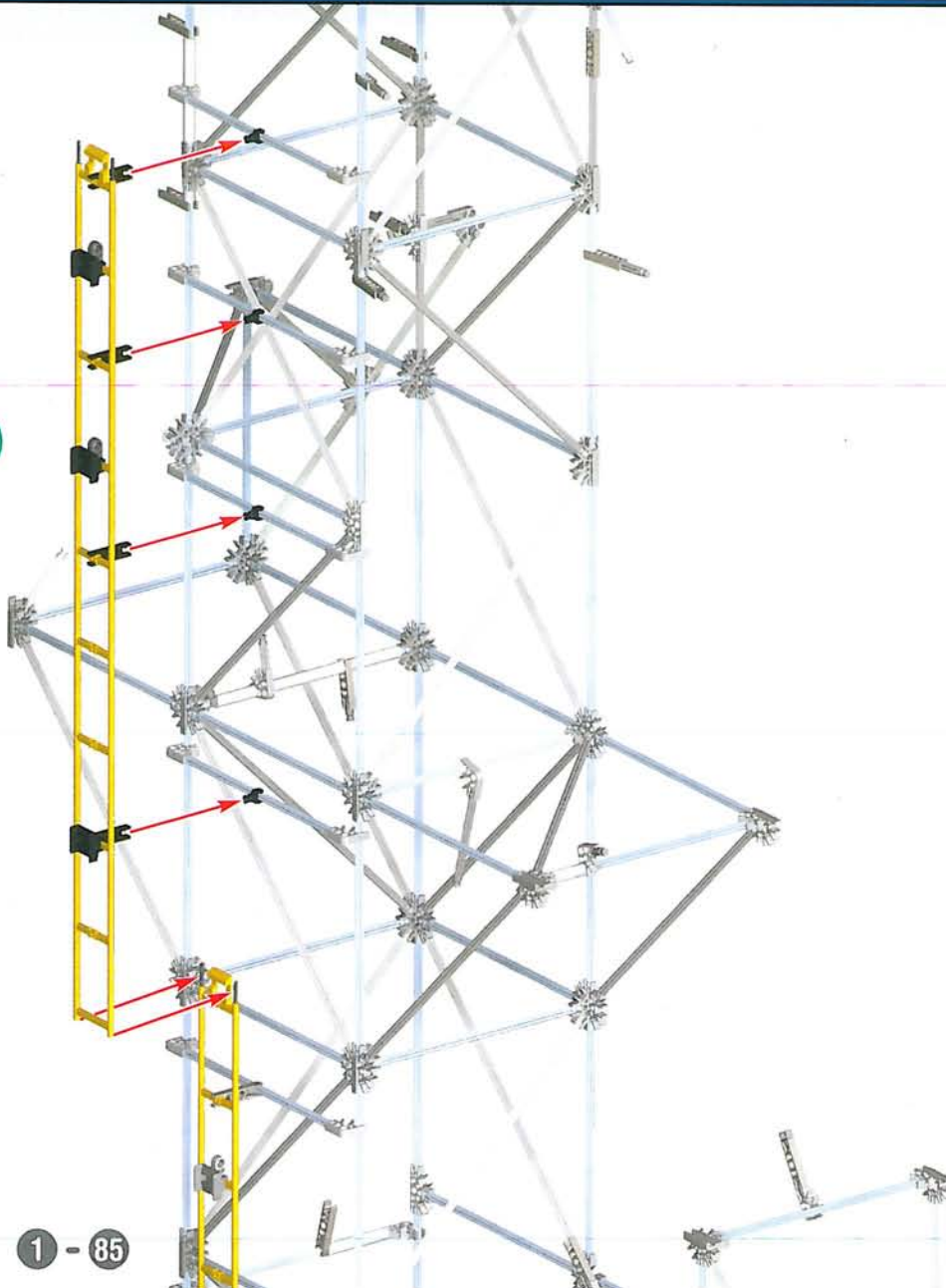

1 - 85

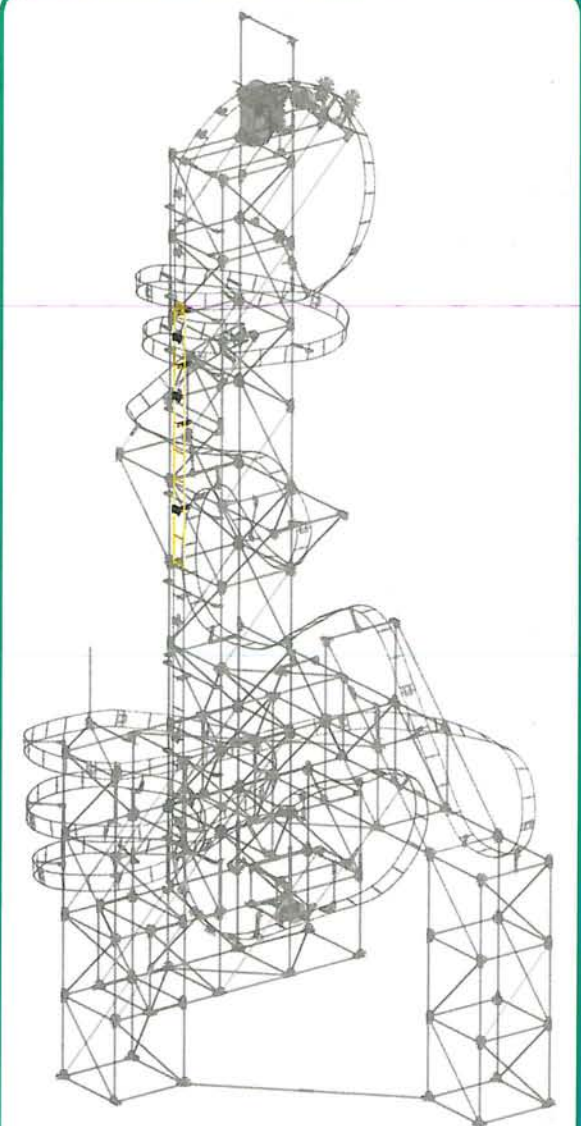

1 - 87

88

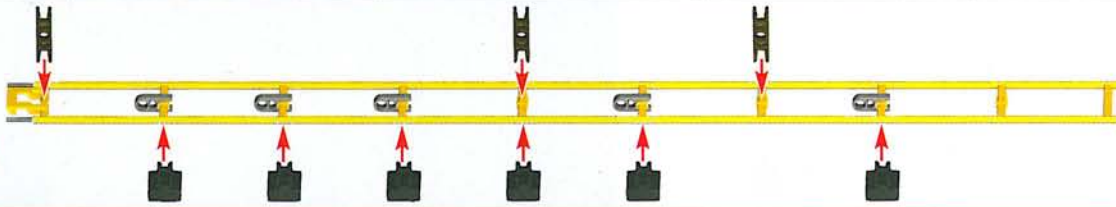

89

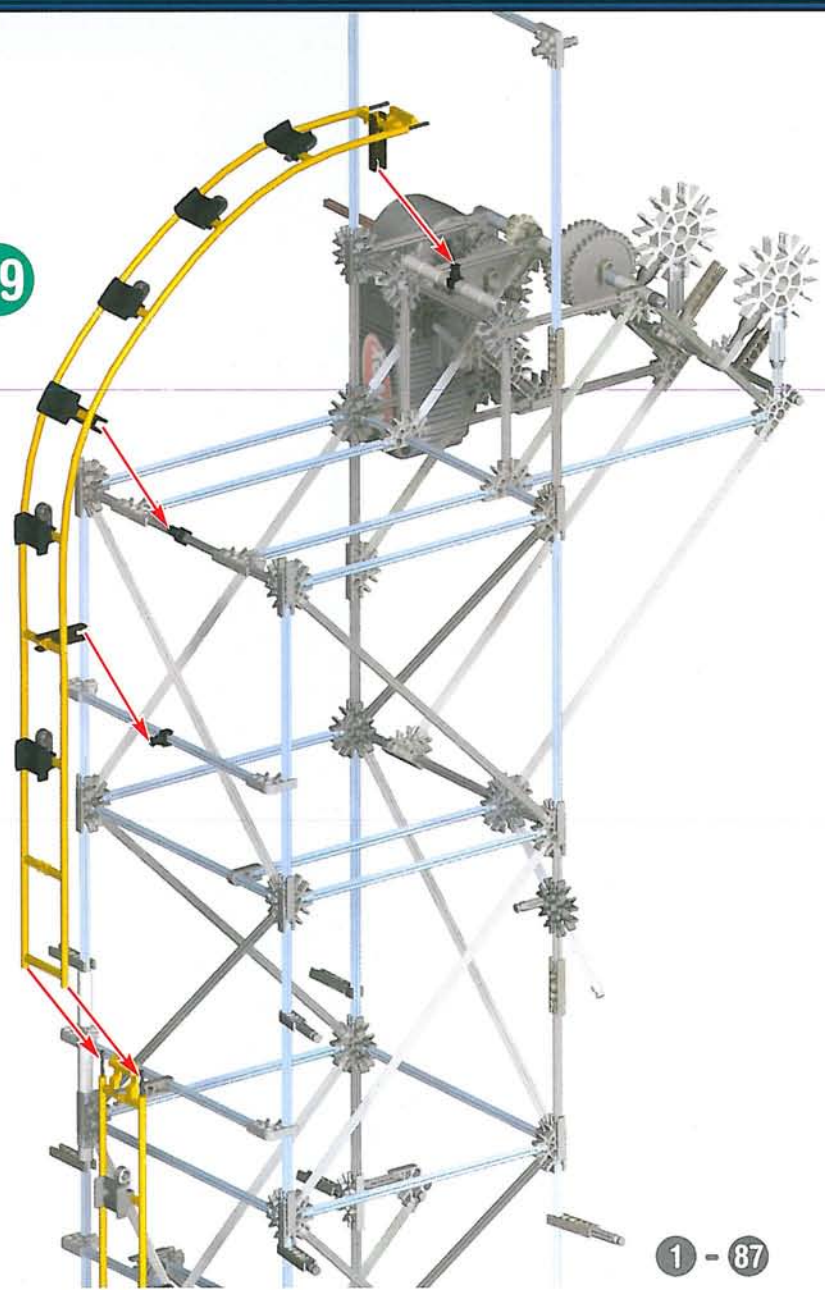

1 - 87

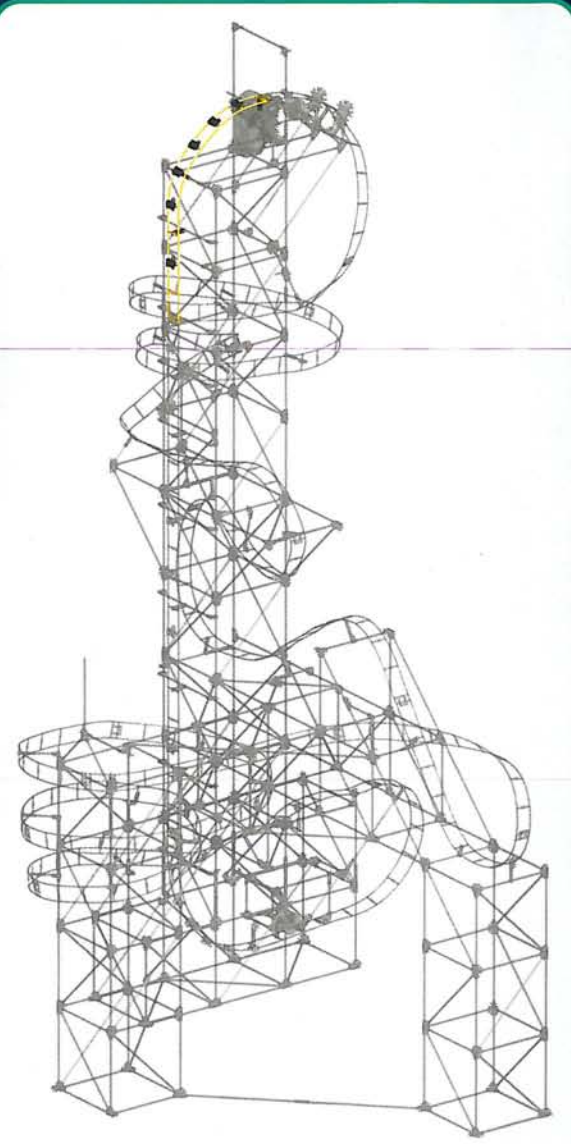

1 - 89

90

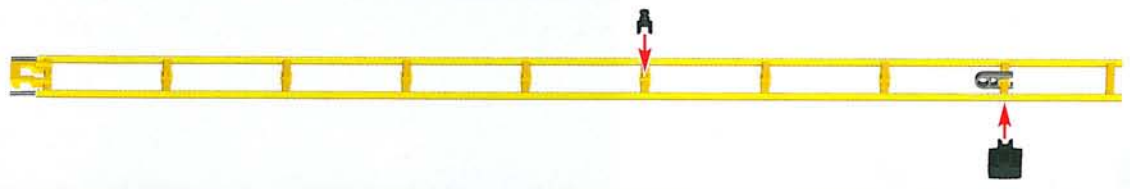

91

1 - 89

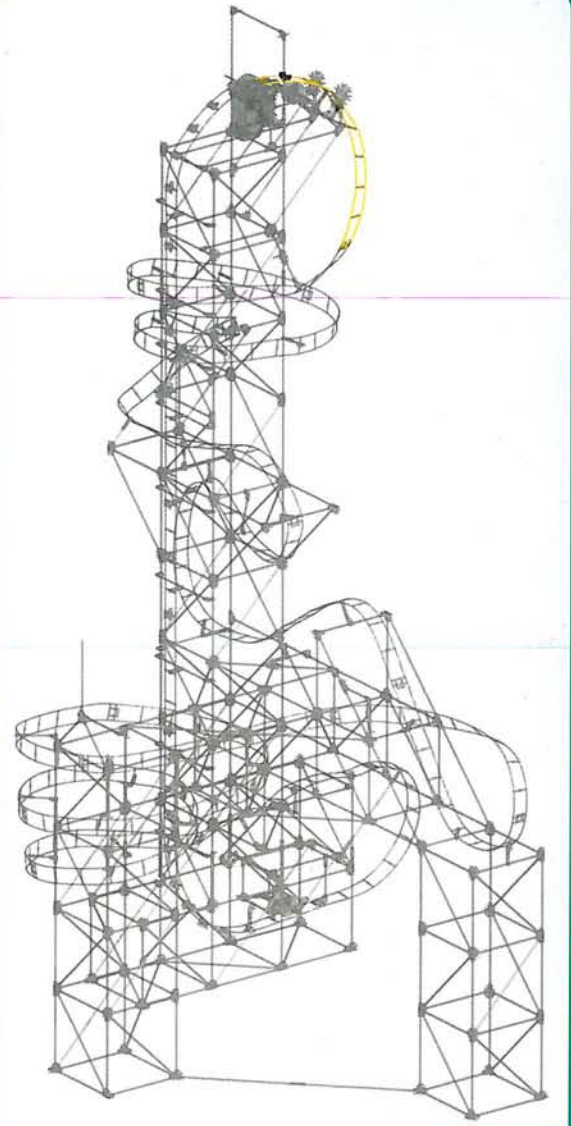

1 - 91

92

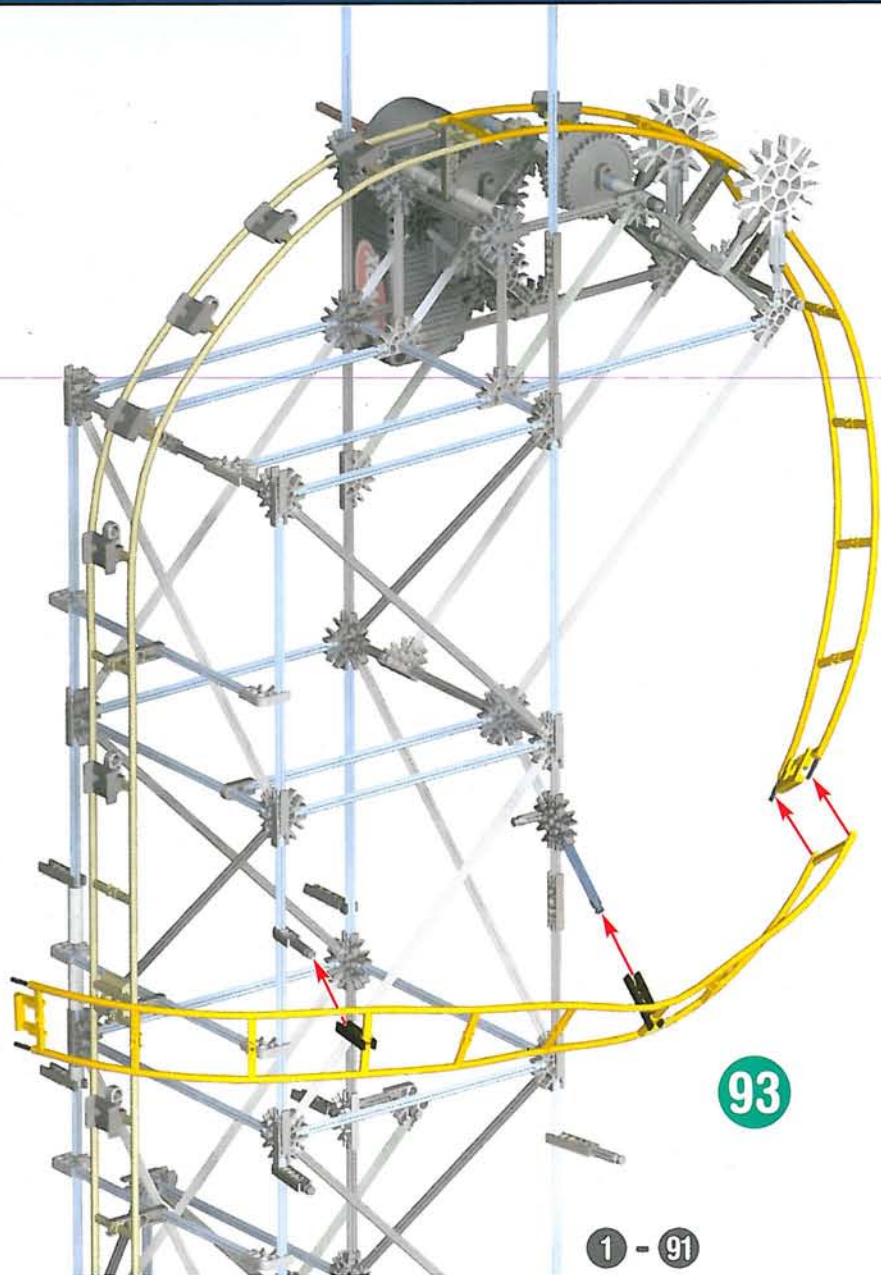

93

1 - 91

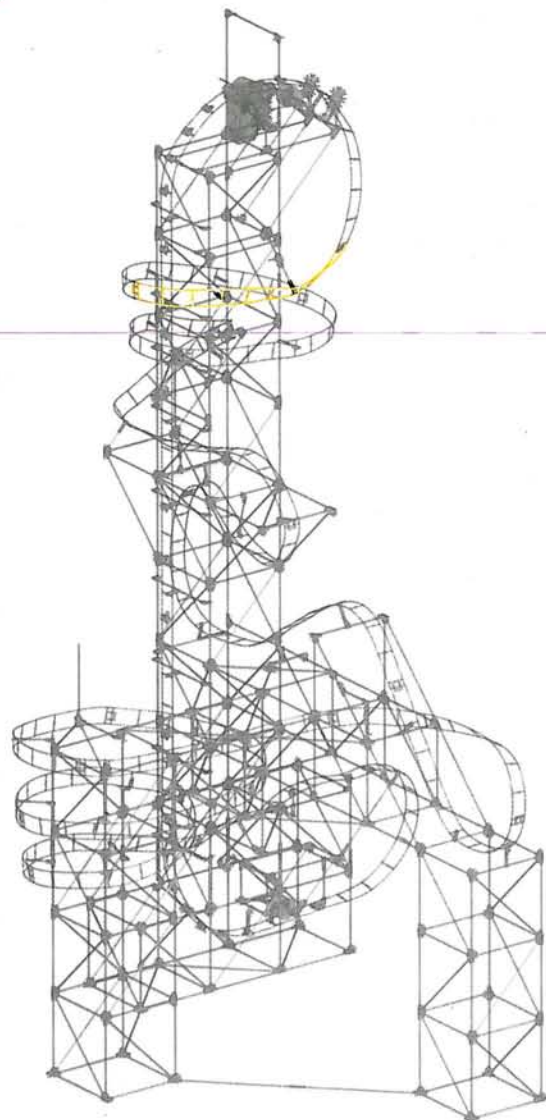

1 - 93

94

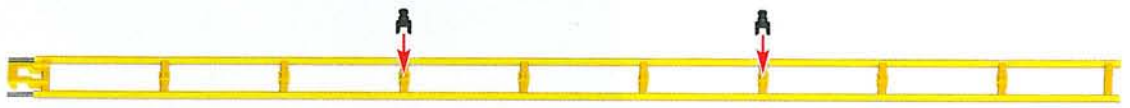

95

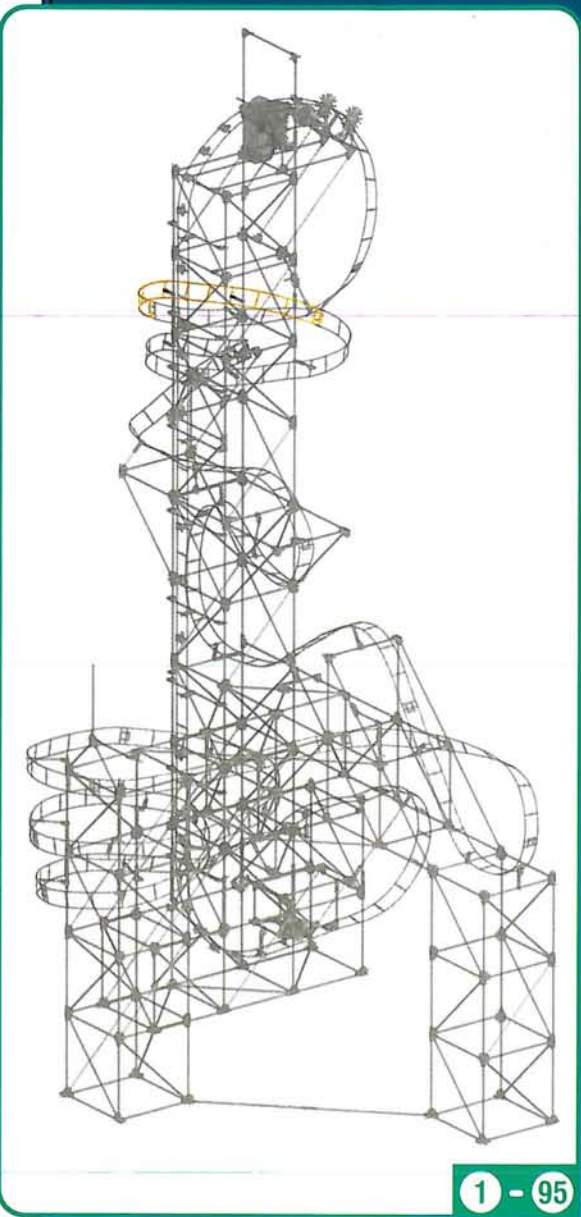
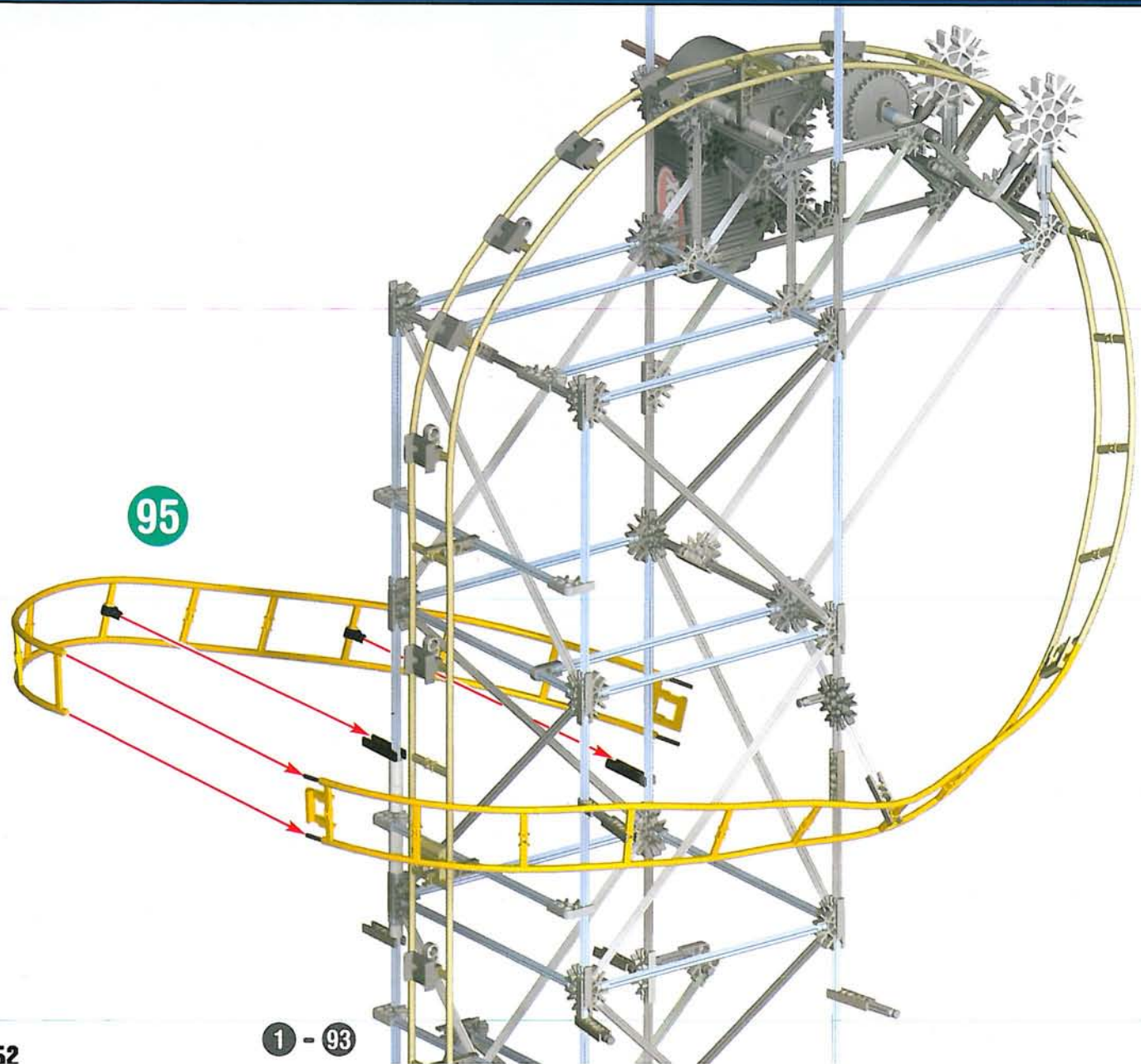

96

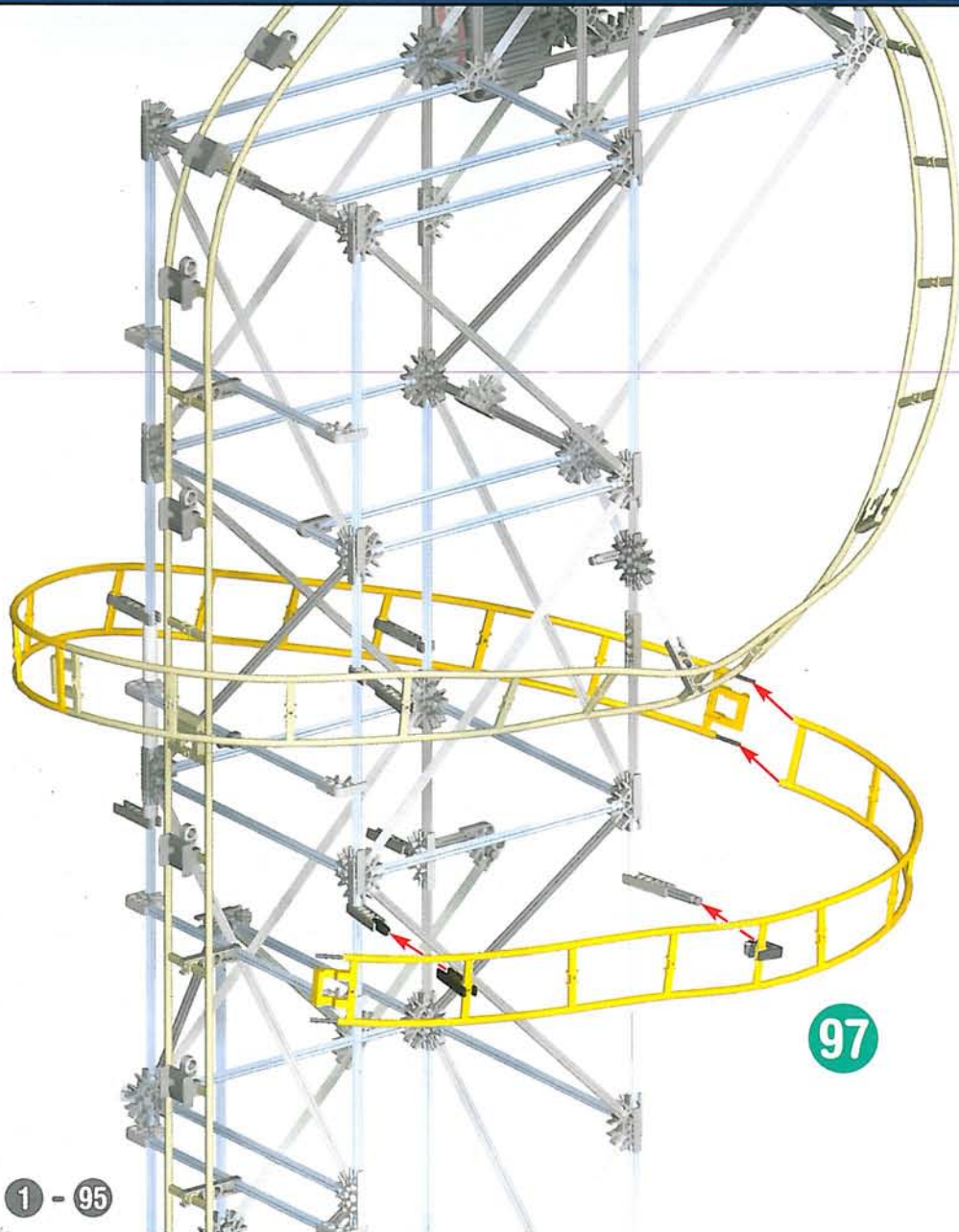
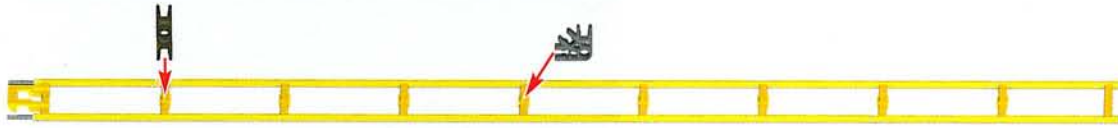

97

1 - 95

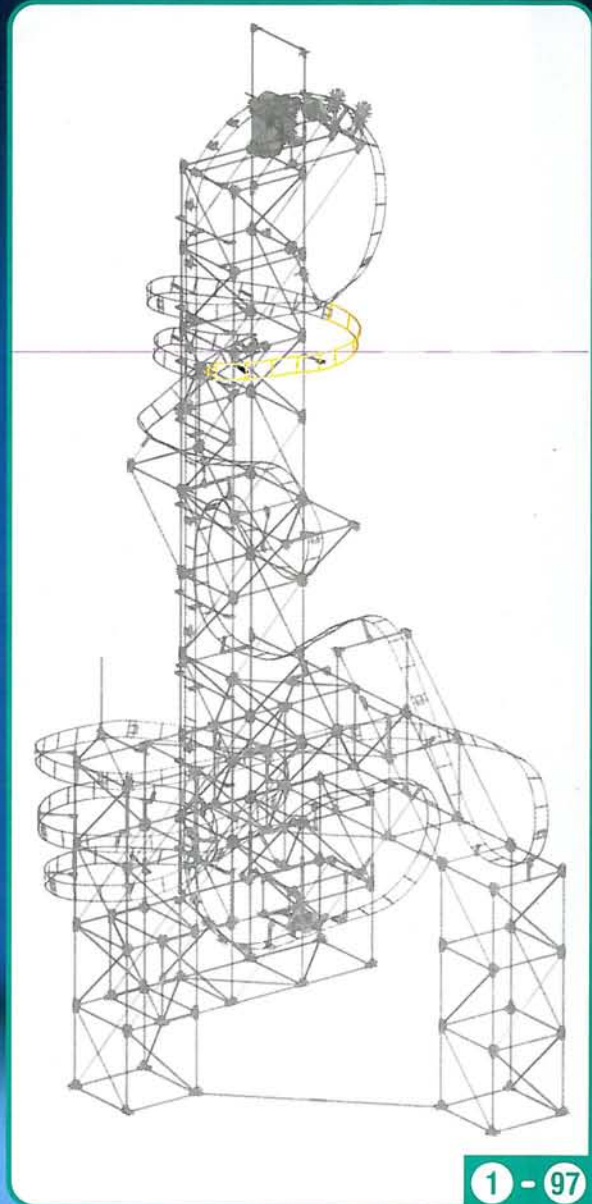

1 - 97

98

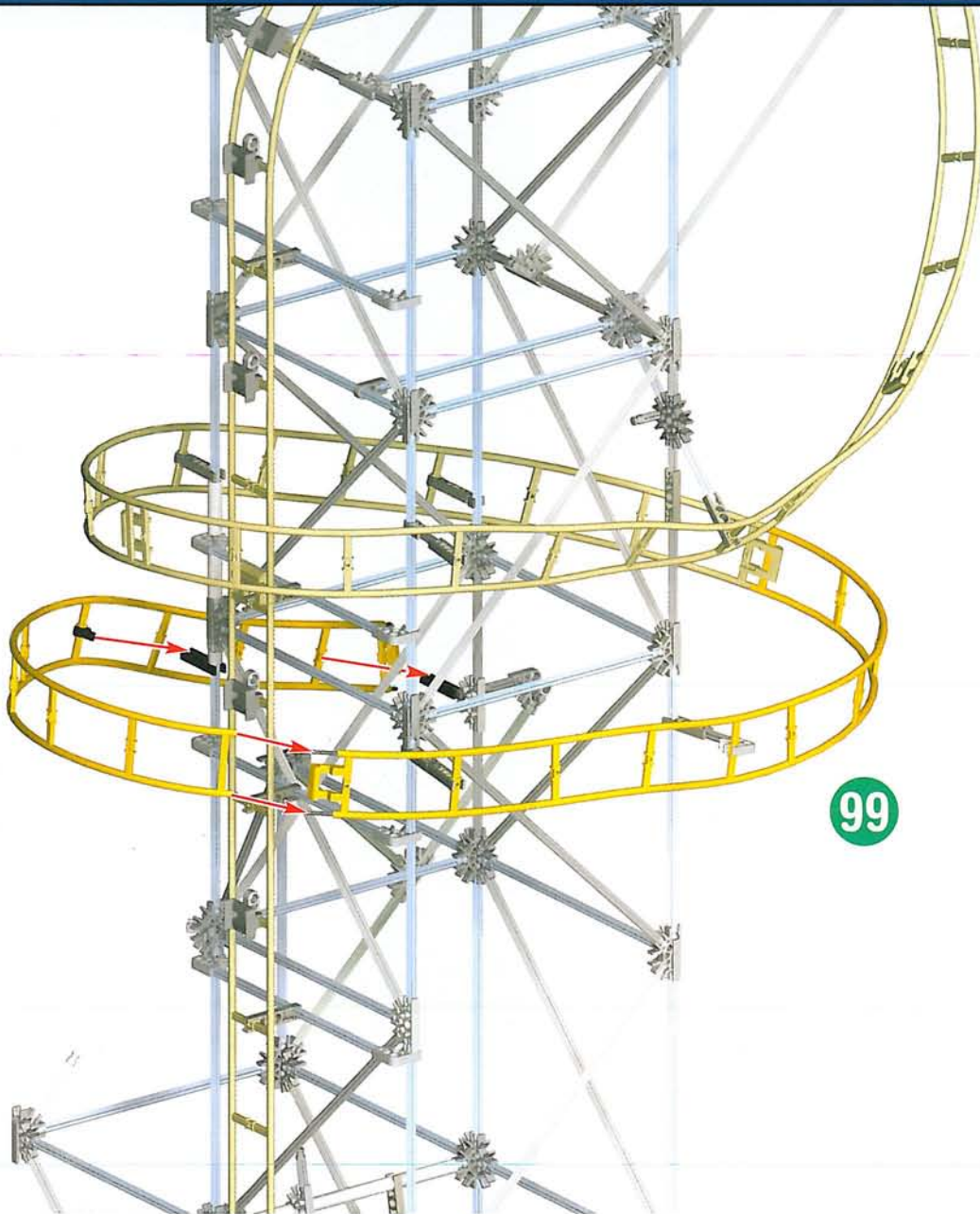
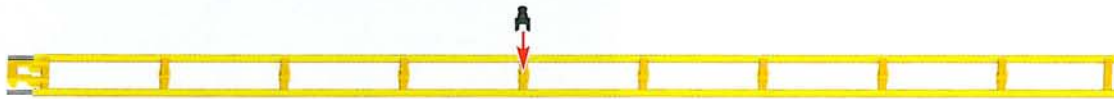

99

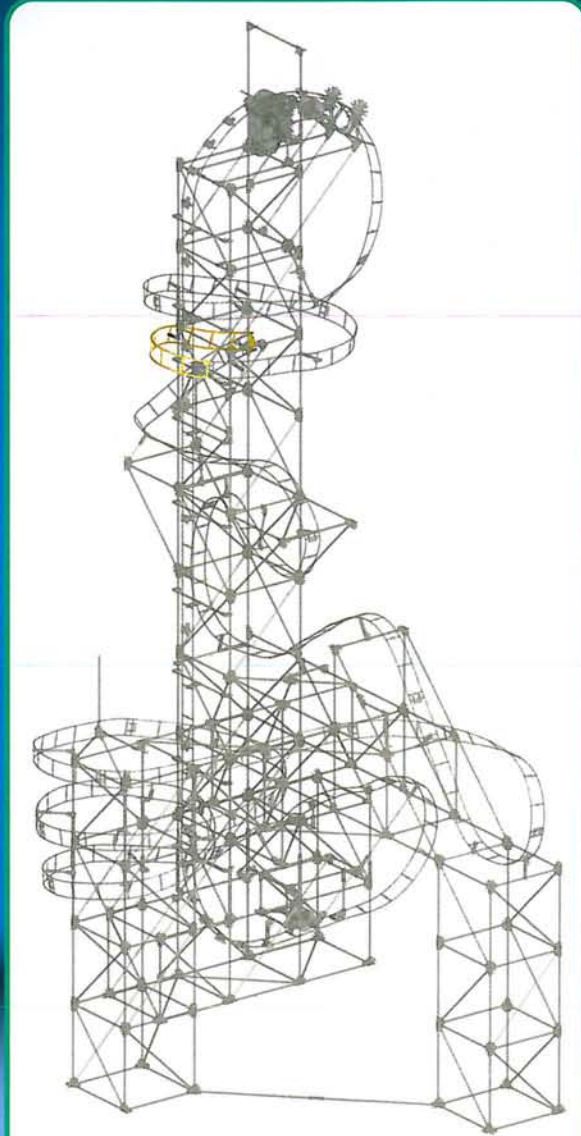

1 - 99

100



101

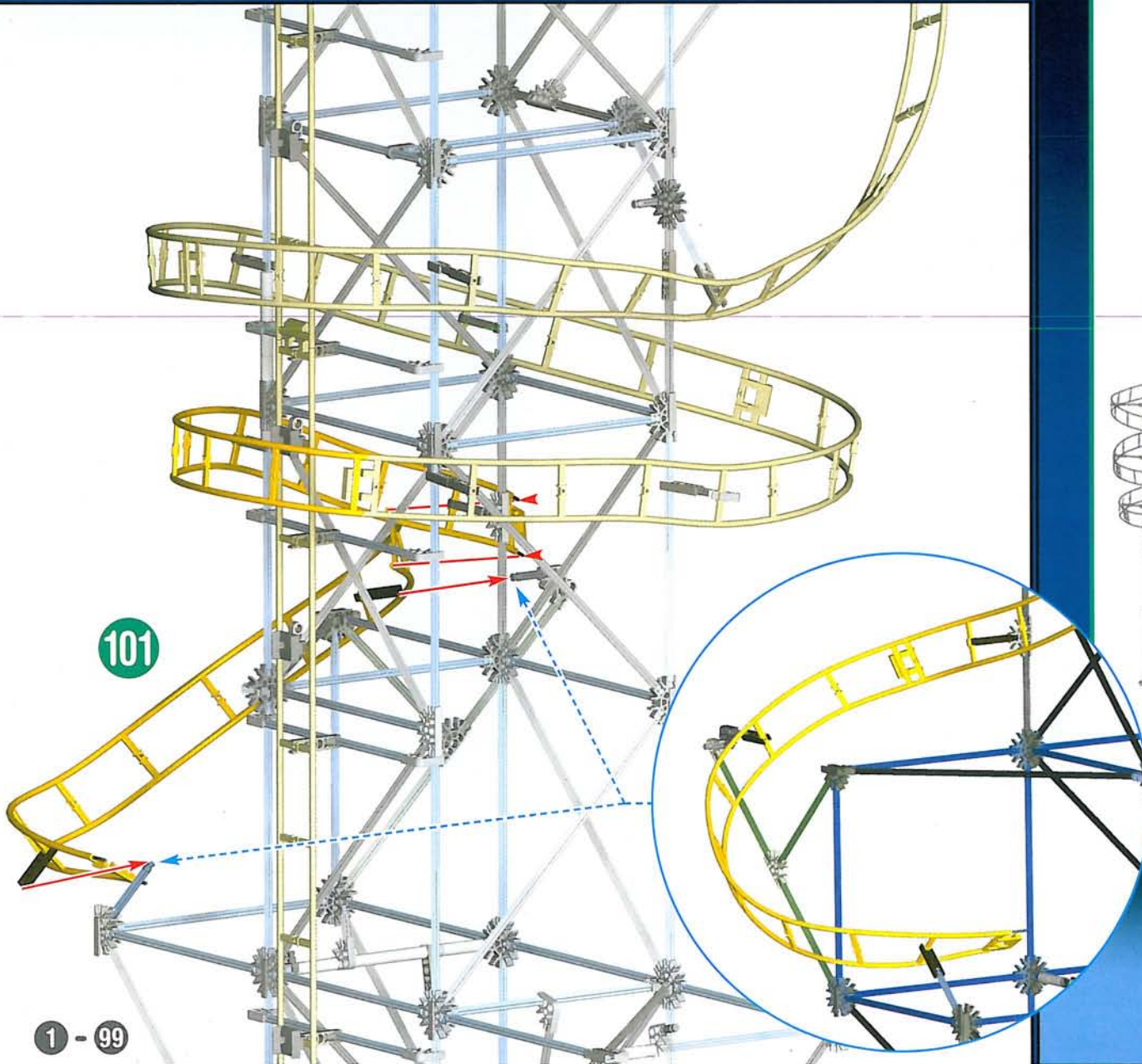

1 - 99

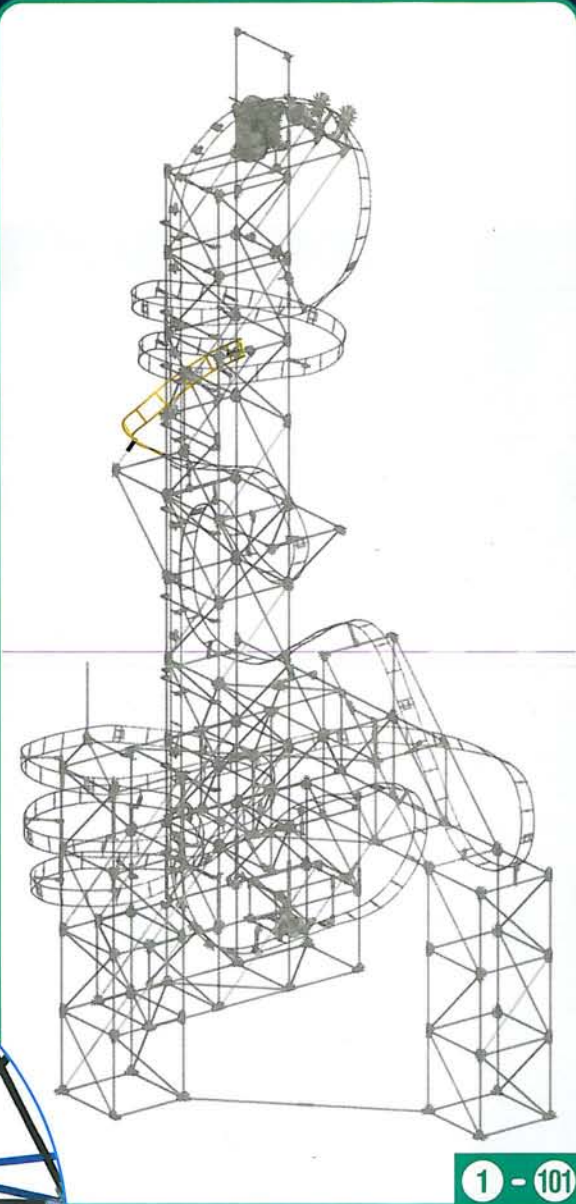

1 - 101

102

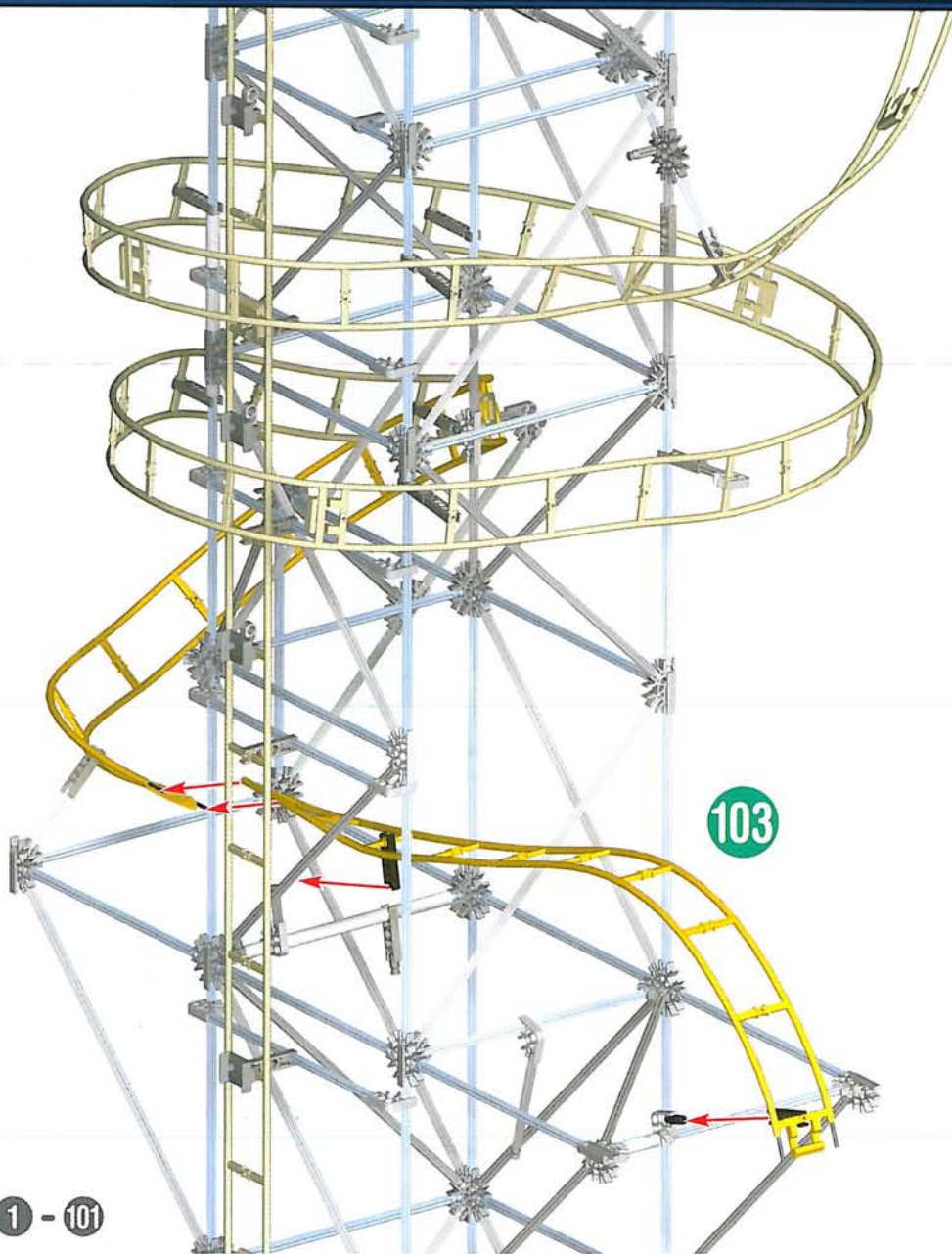

103

1 - 101

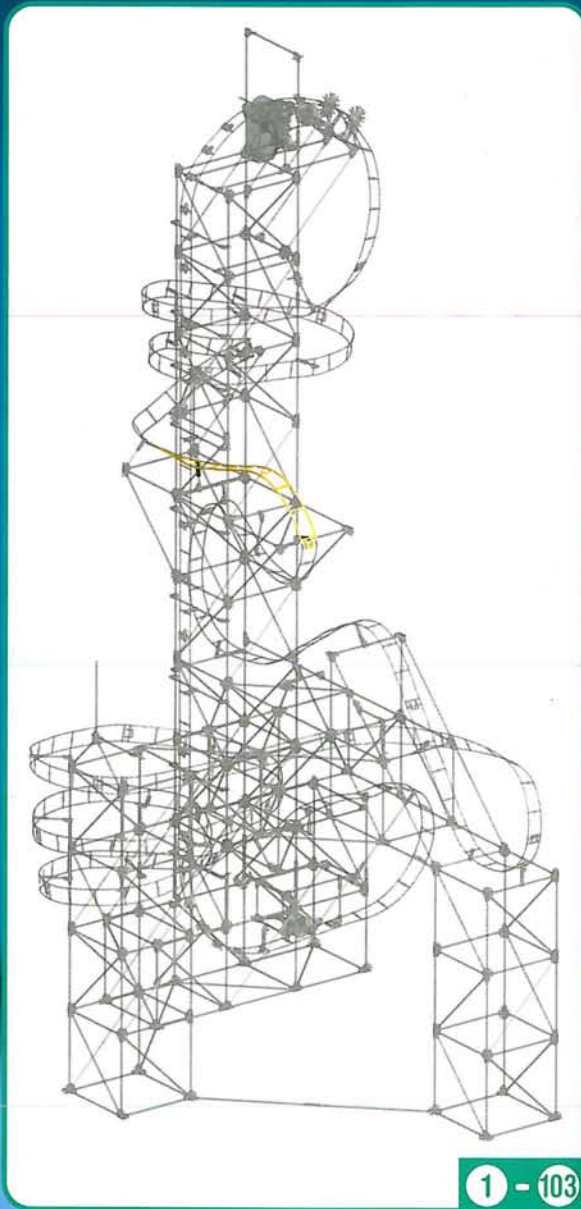

1 - 103

104

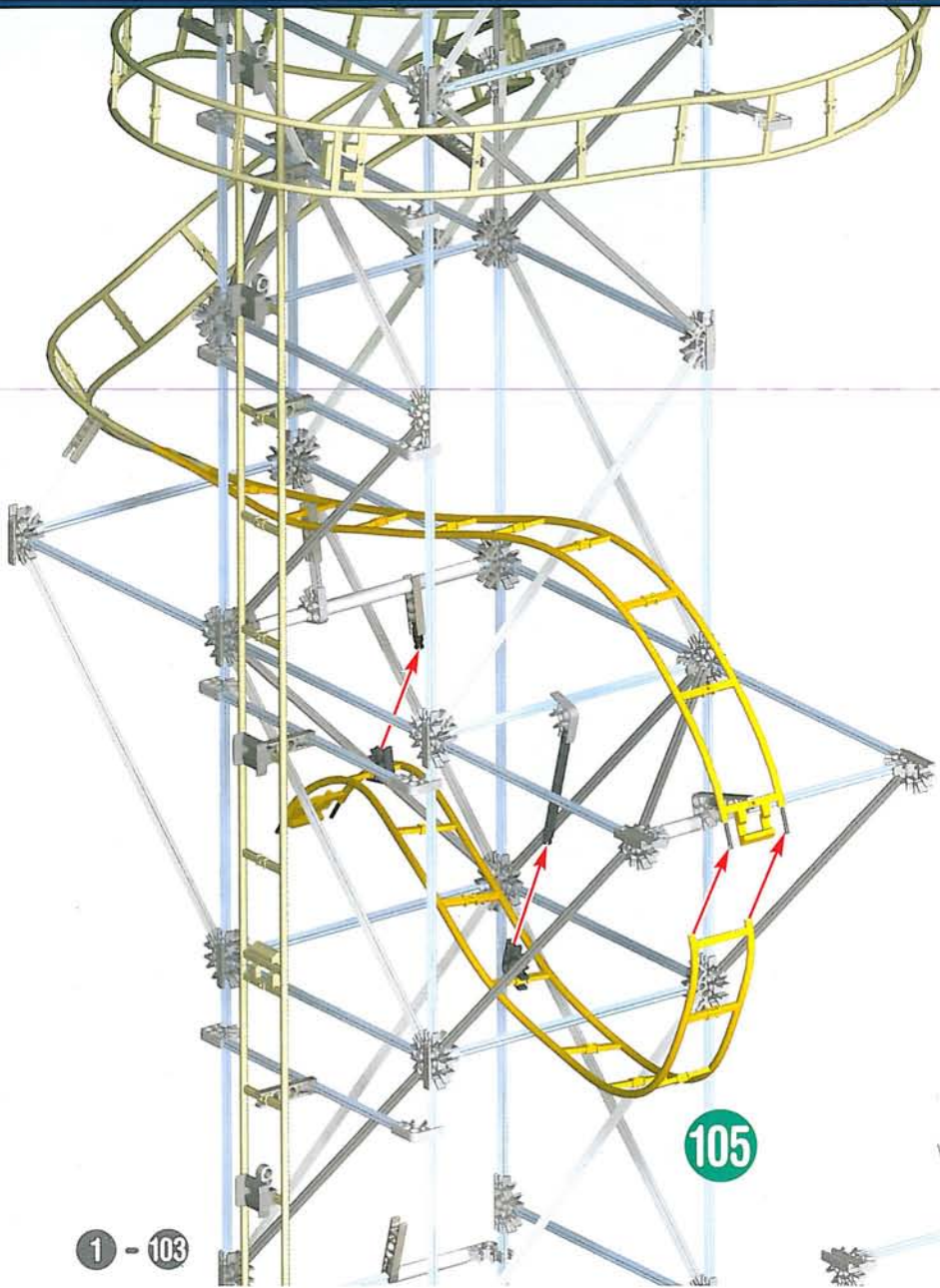
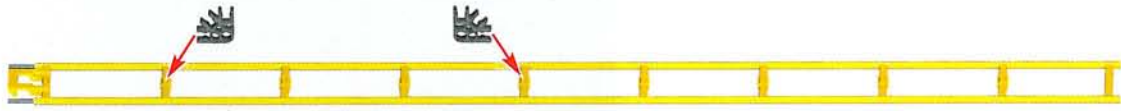

105

1 - 103

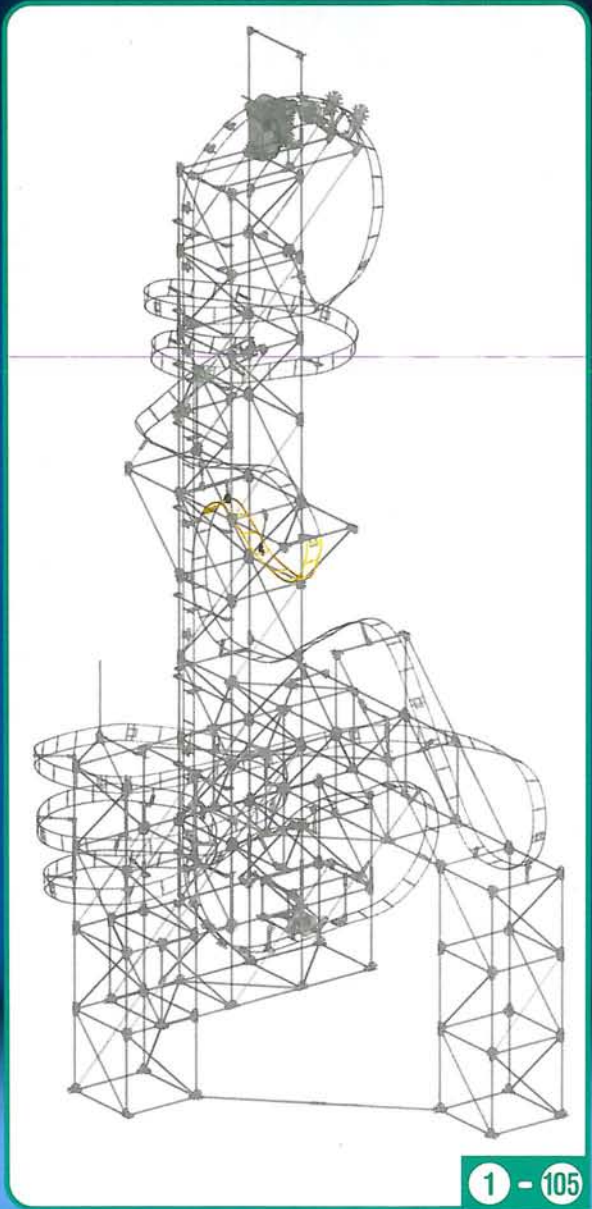

1 - 105

106

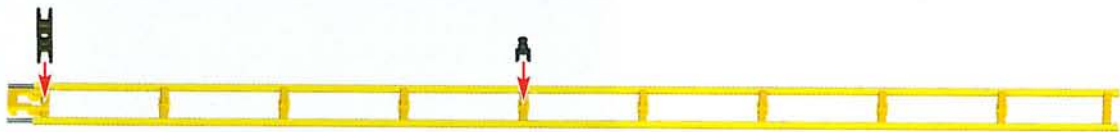

107

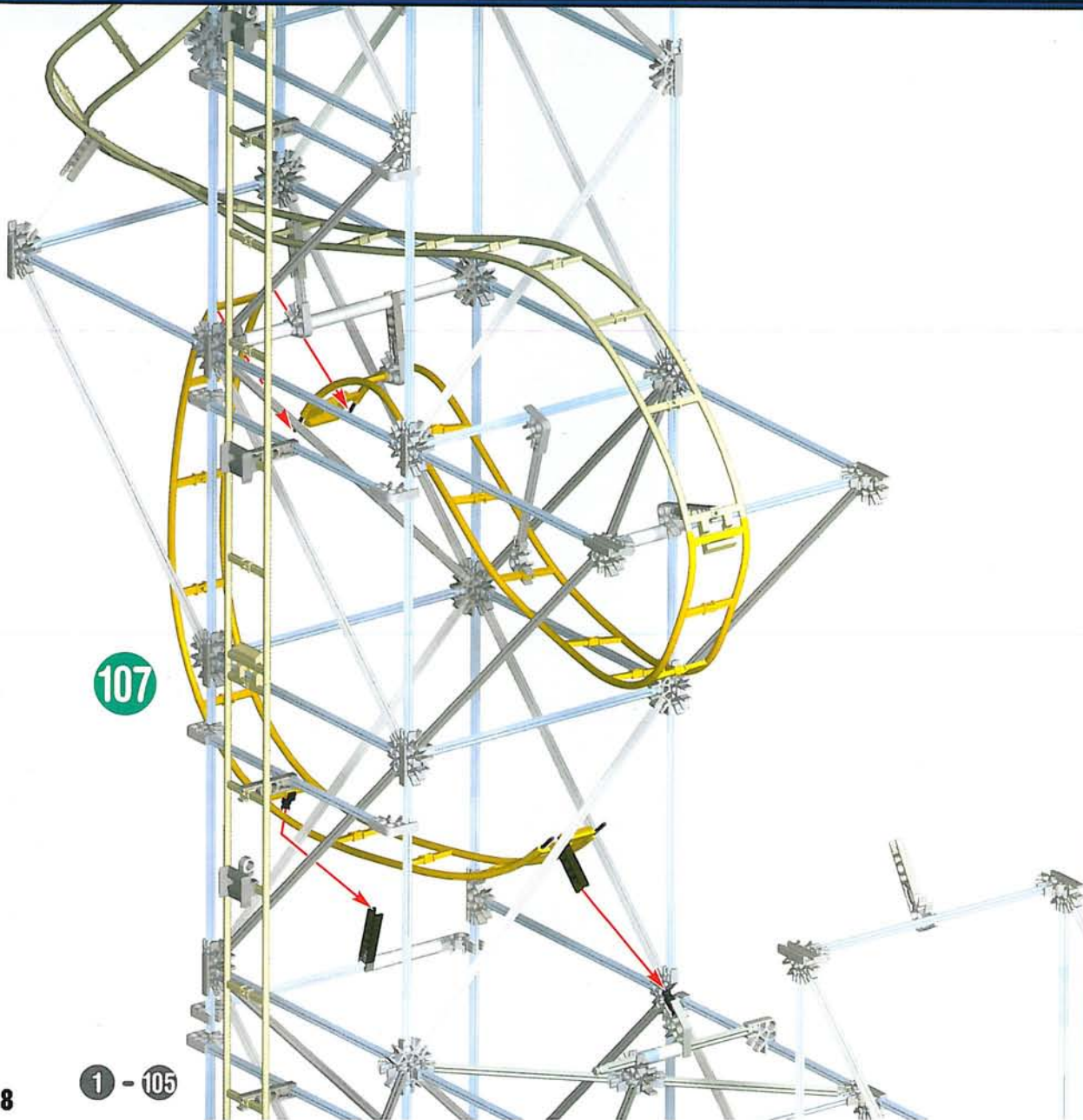

1 - 105

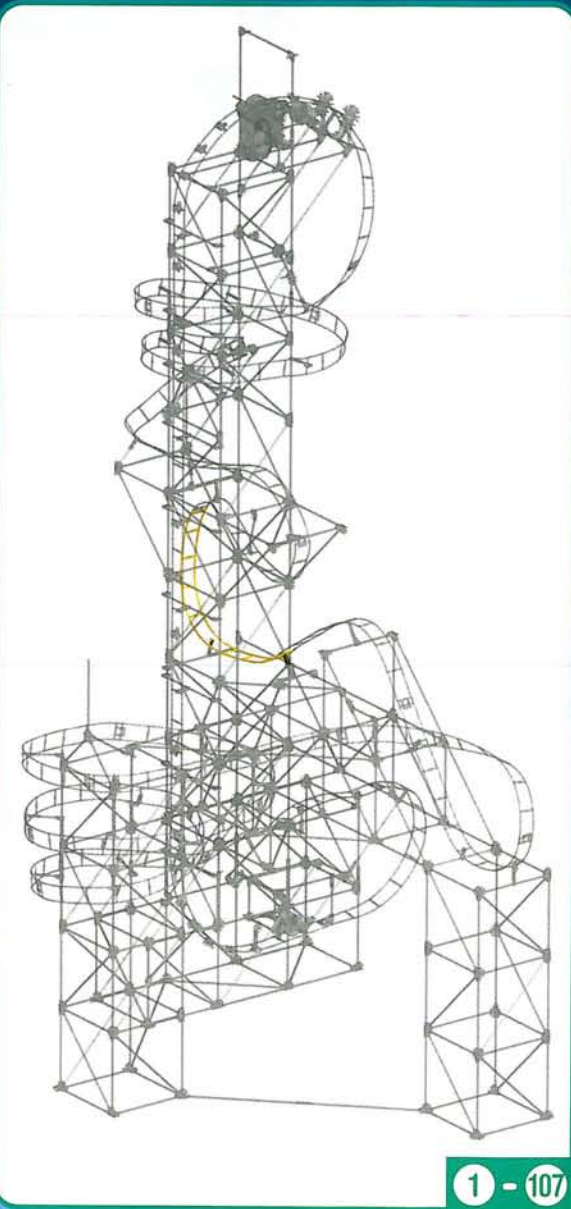

1 - 107

108

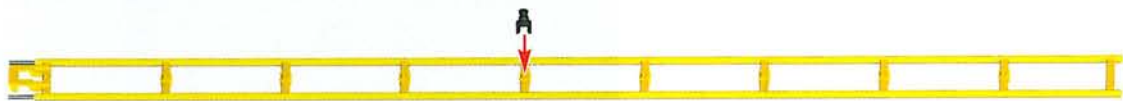

109

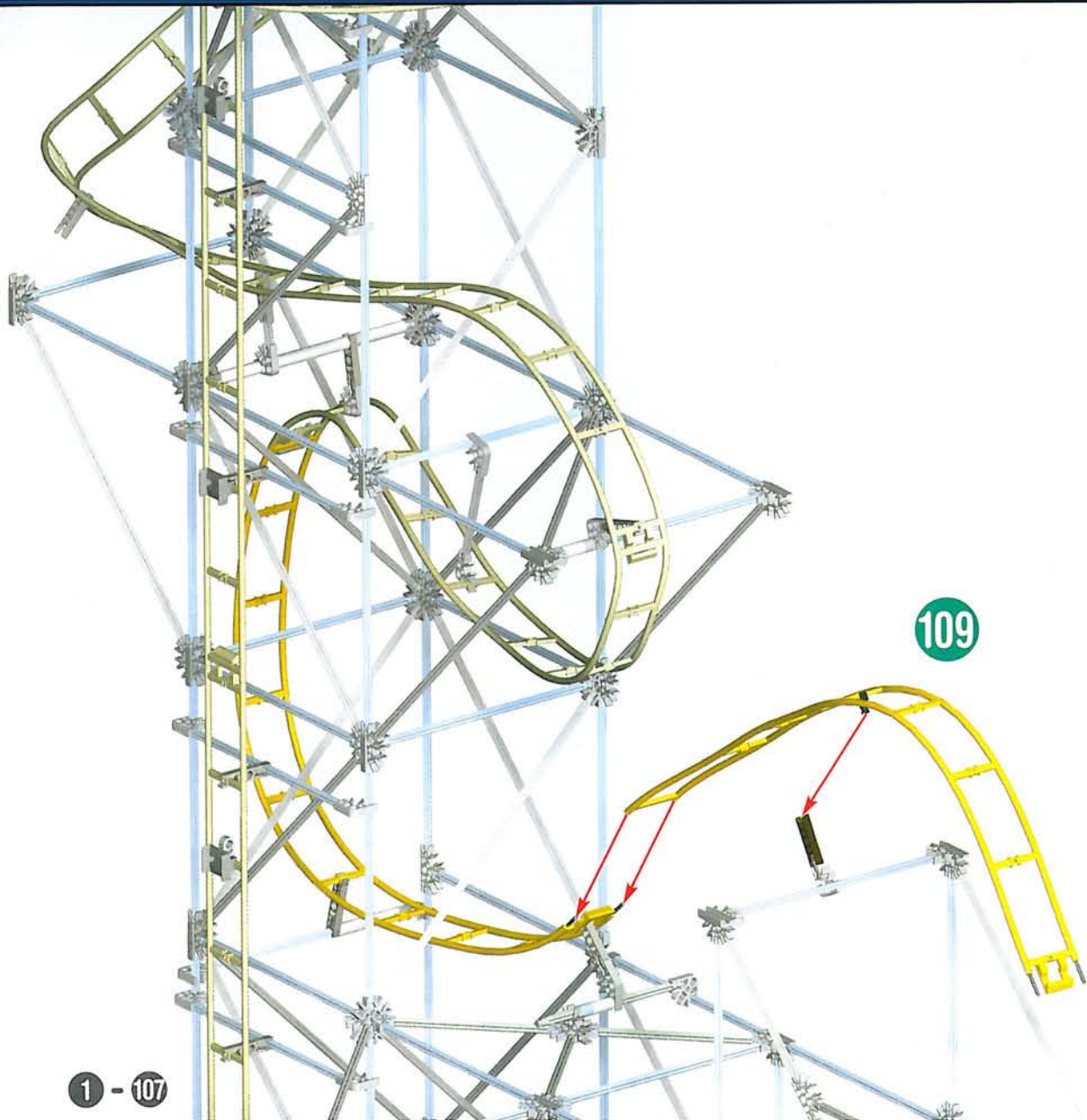

1 - 107

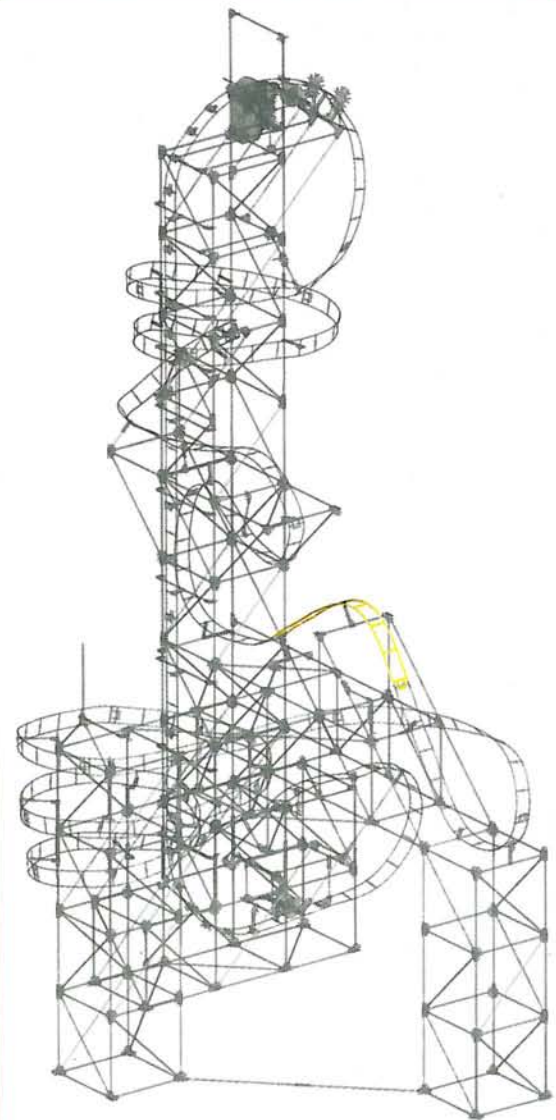

1 - 109

110

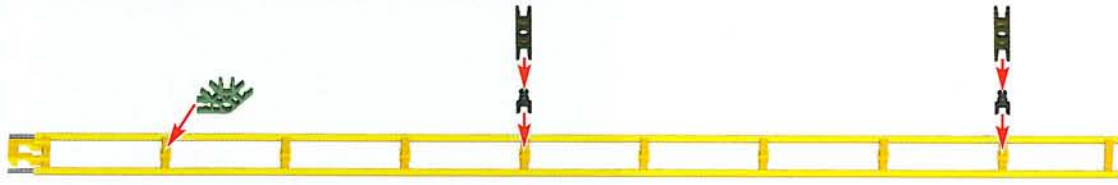

111

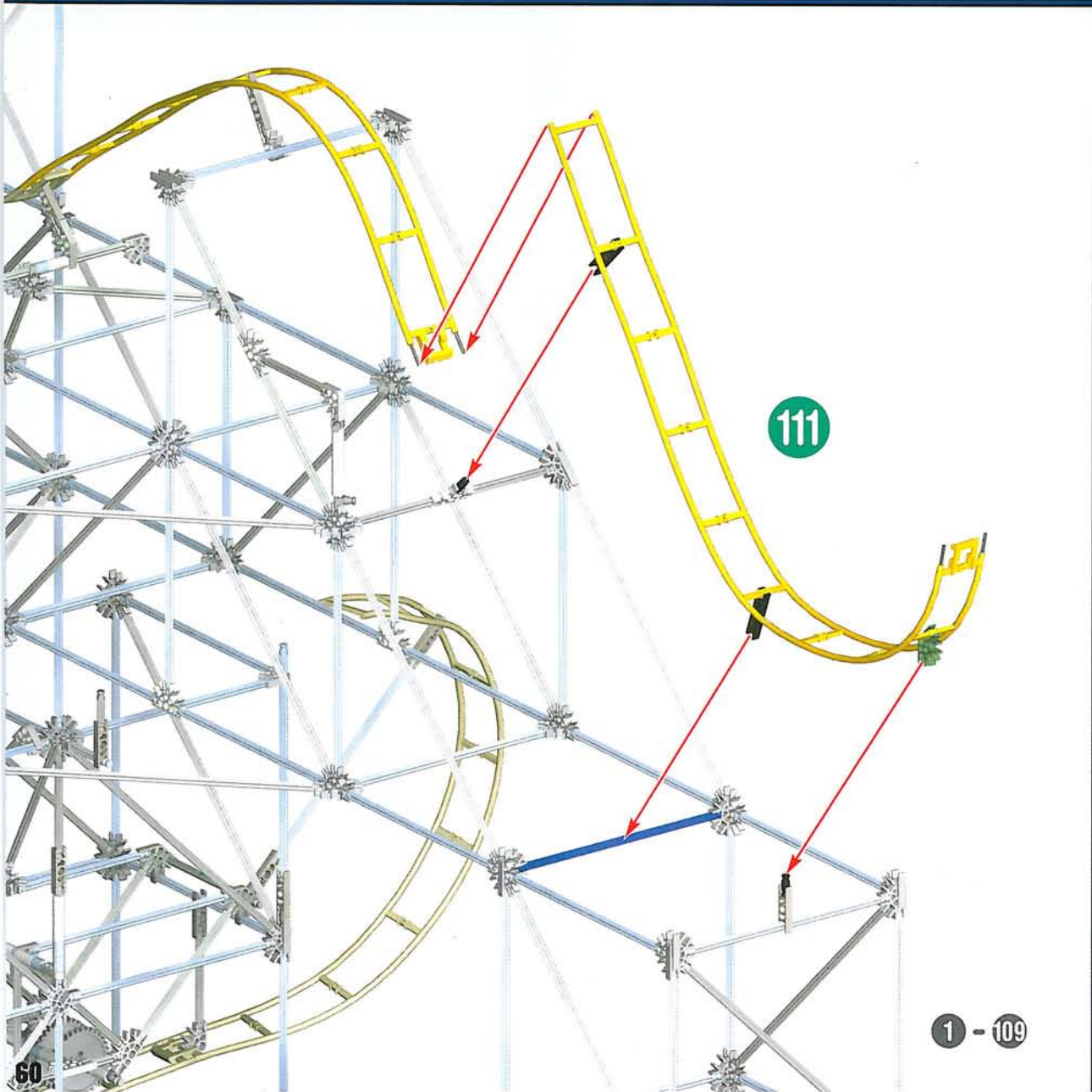

1 - 109

60

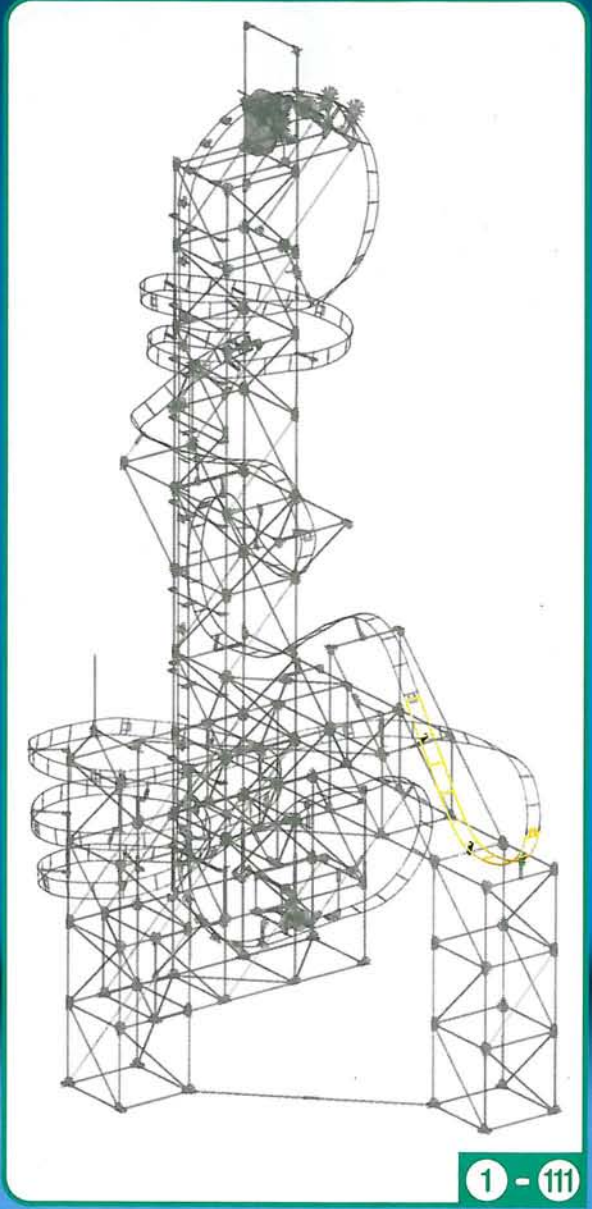

1 - 111

112

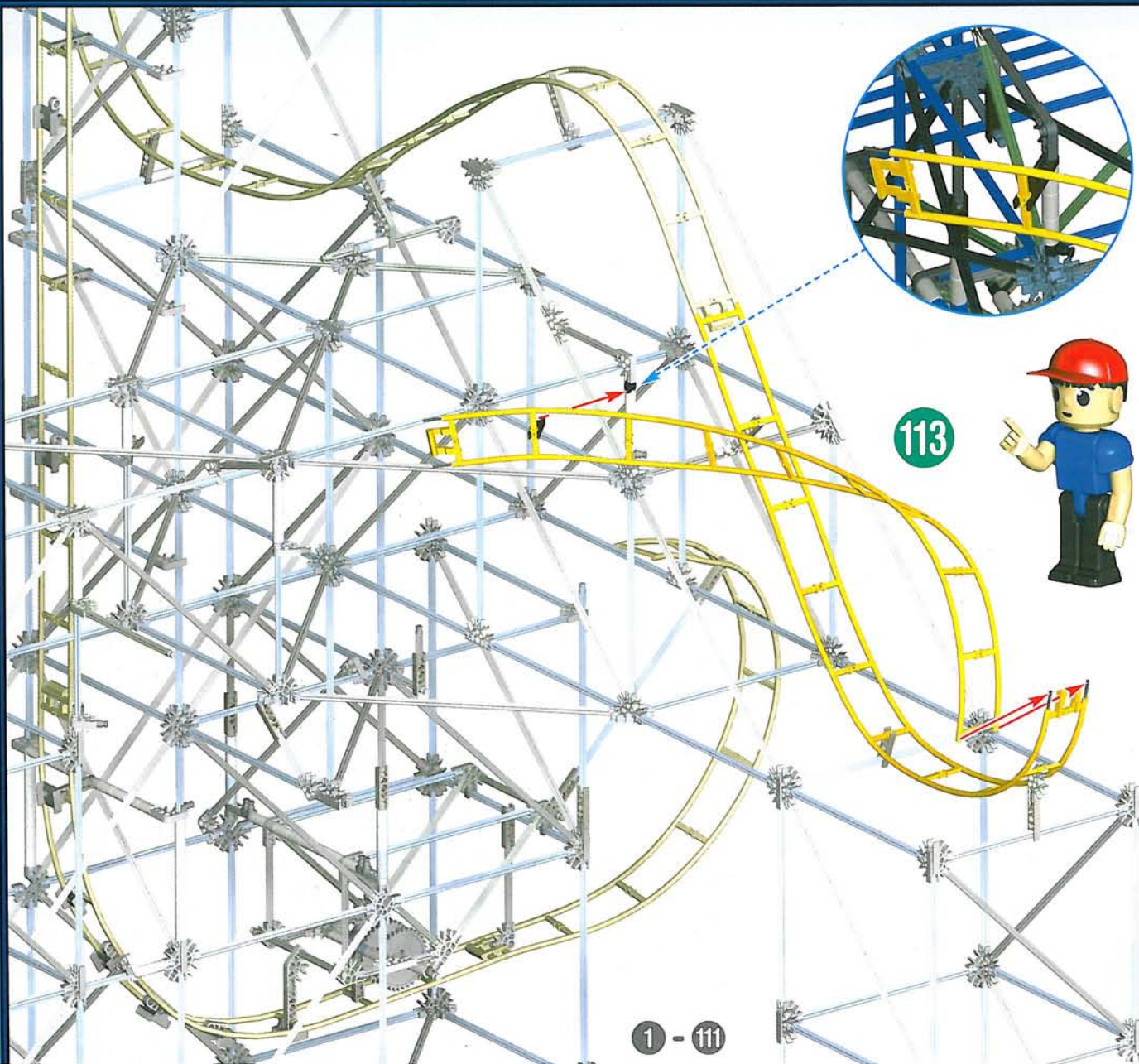
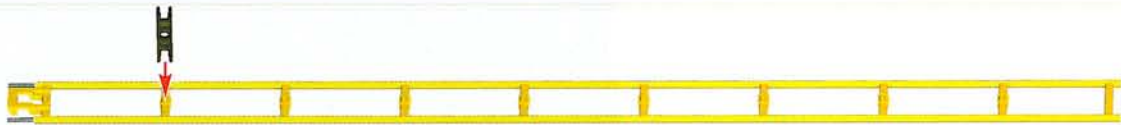

113

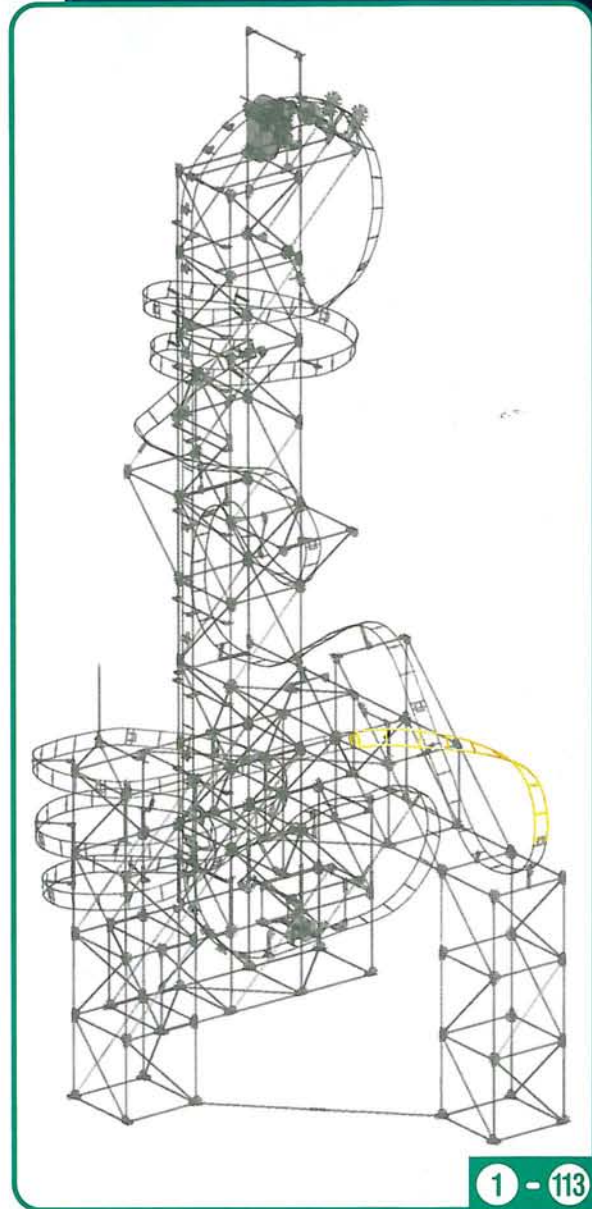

1 - 113

1 - 111

114

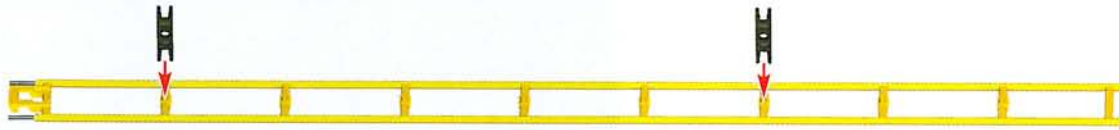

115

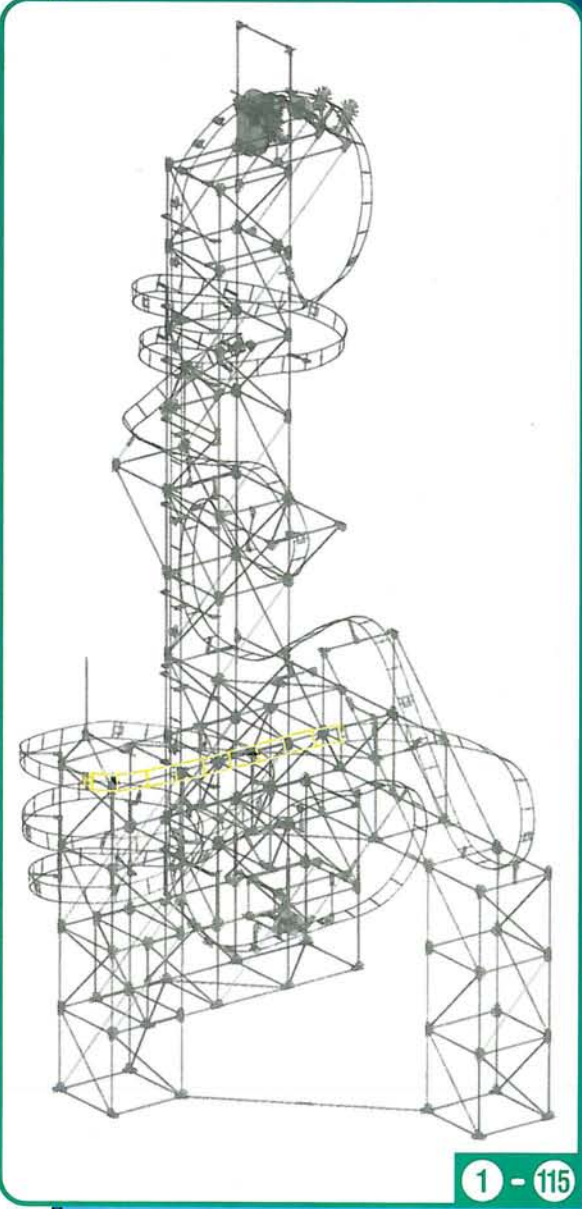
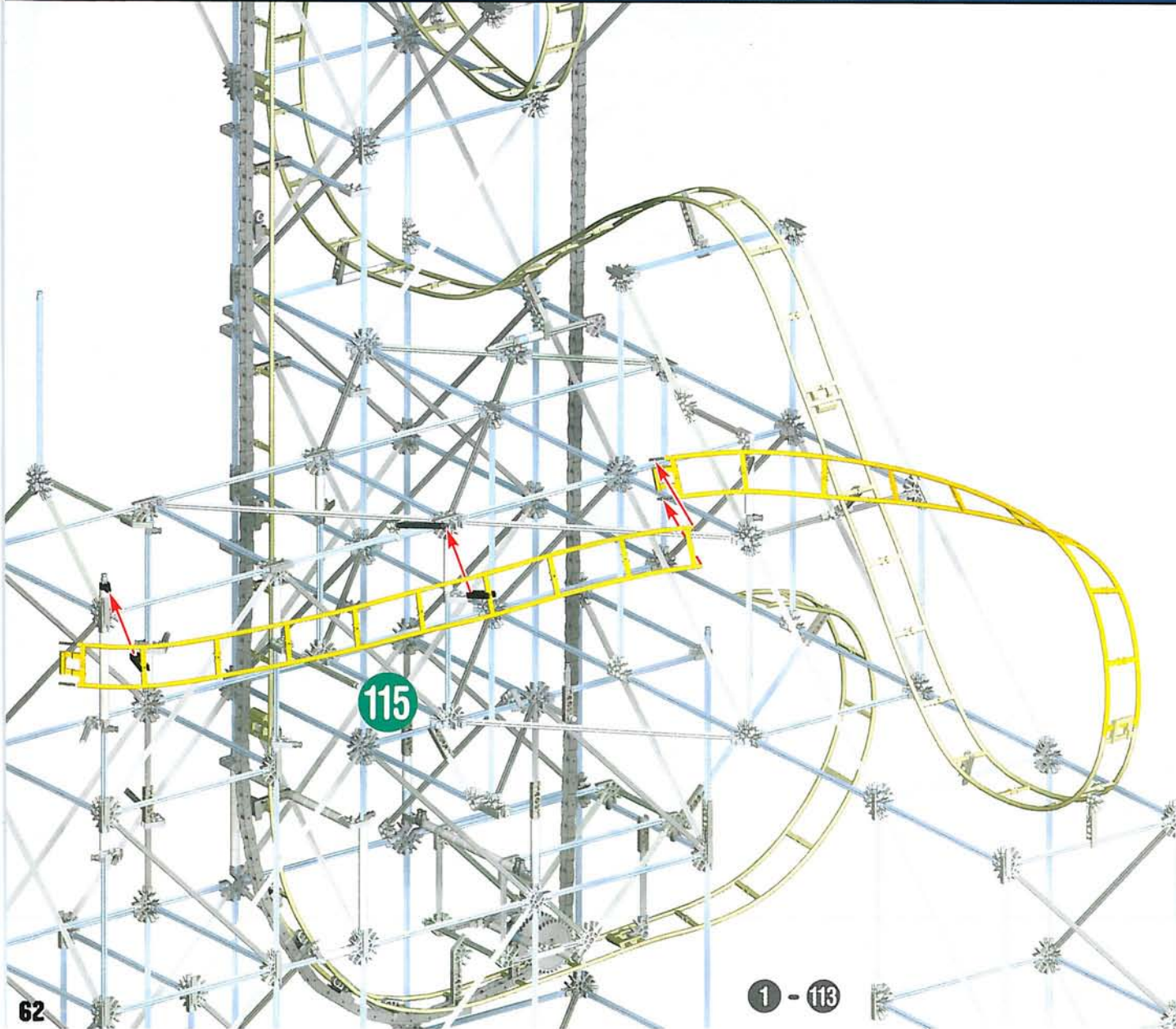

116

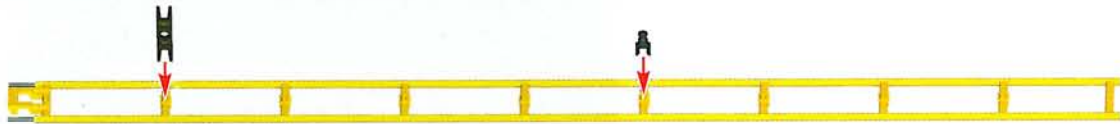

117



1 - 115

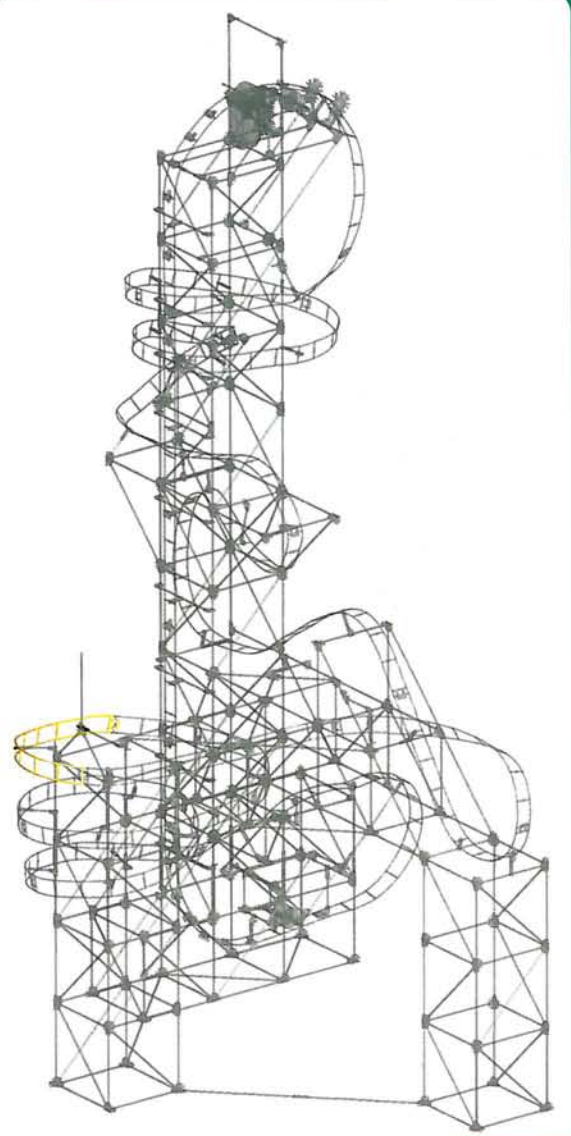

1 - 117

118



119

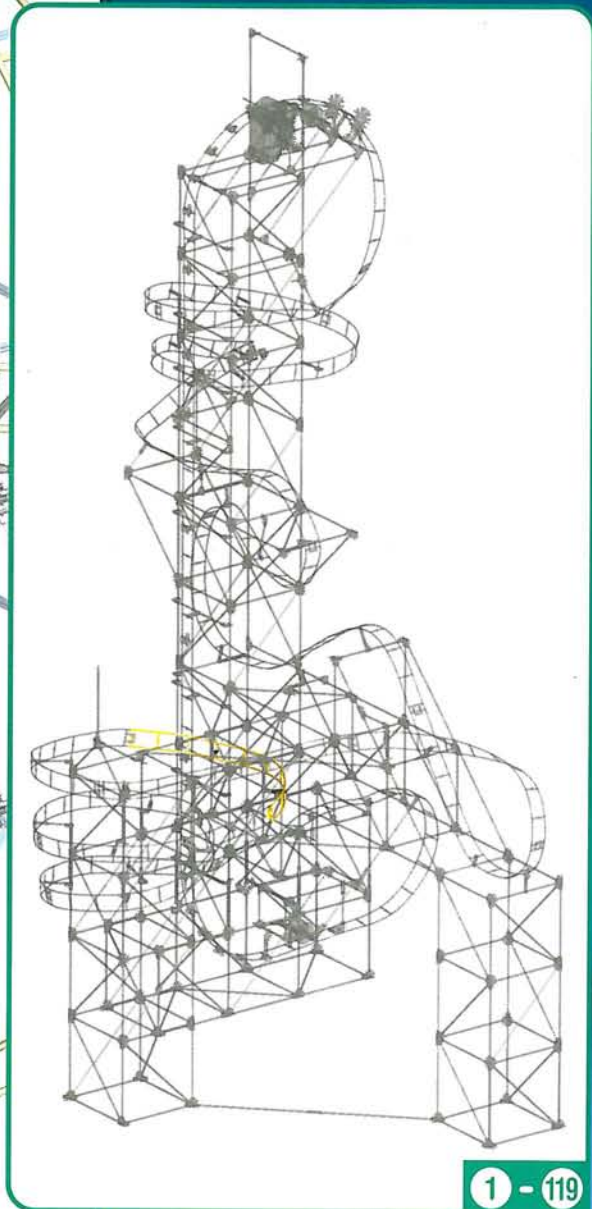
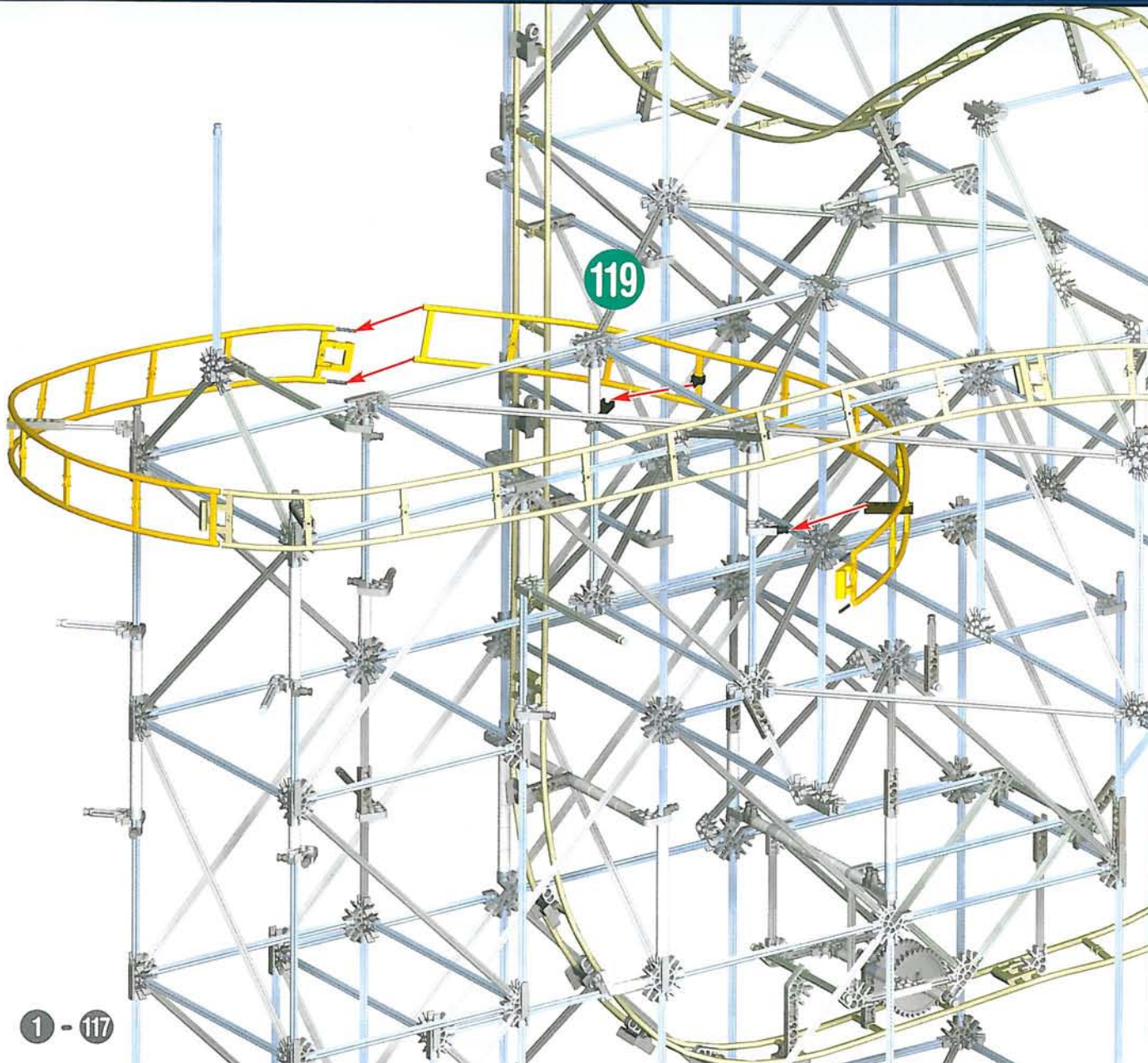

120

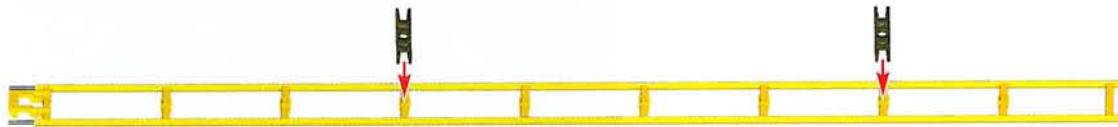

121

1 - 119

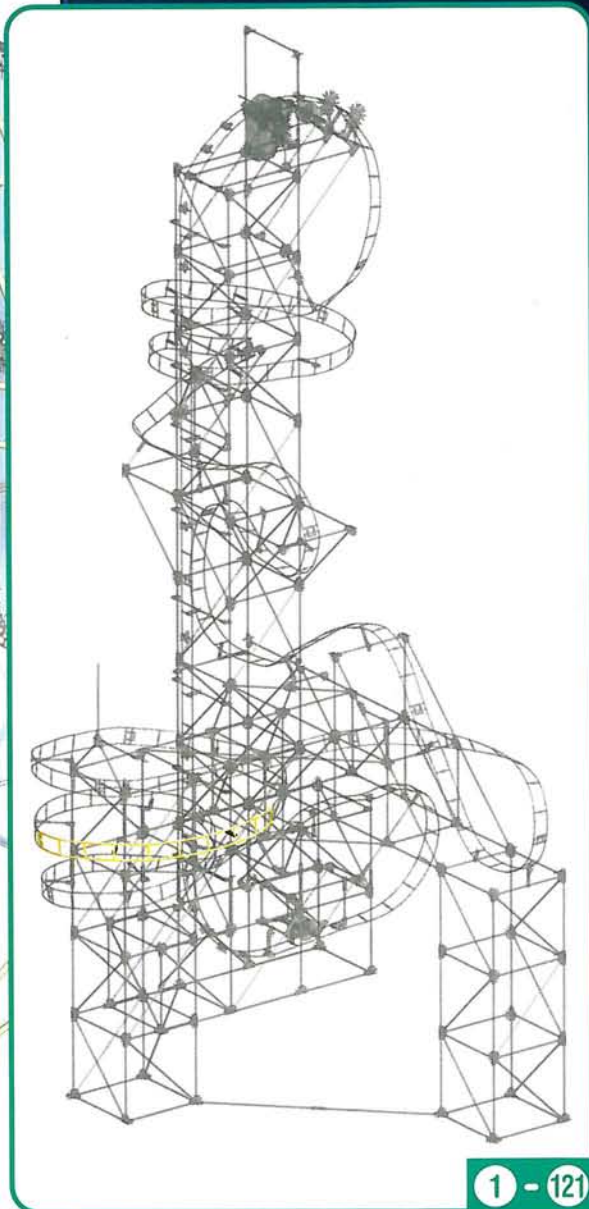

1 - 121

122

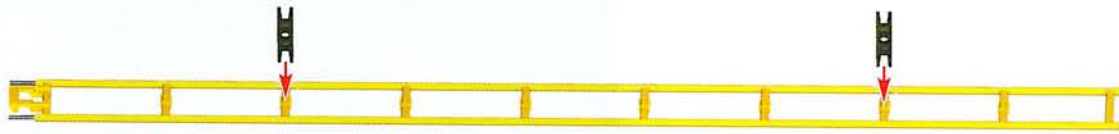

123

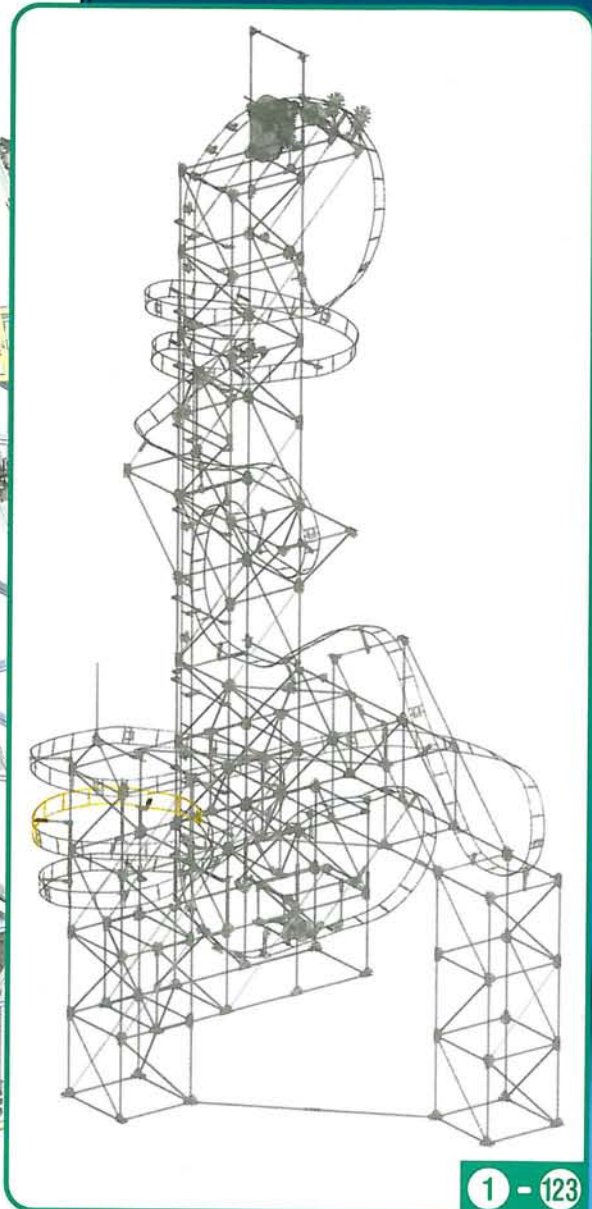

1 - 123

124

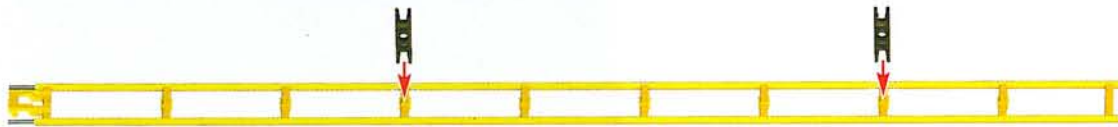

125

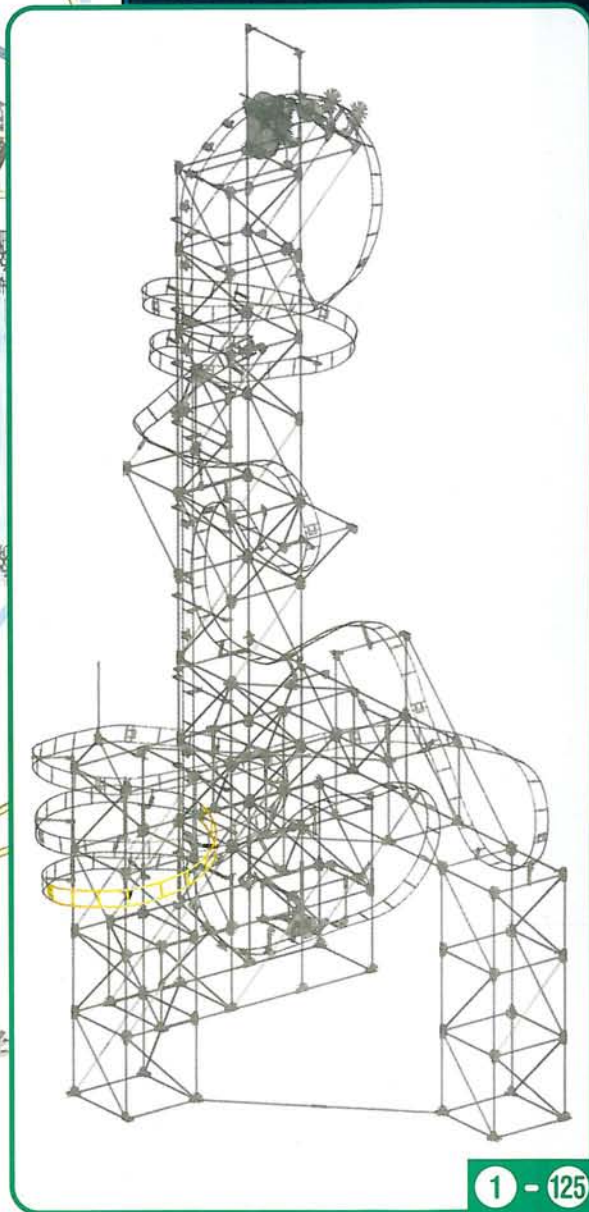

1 - 125

1 - 123

126

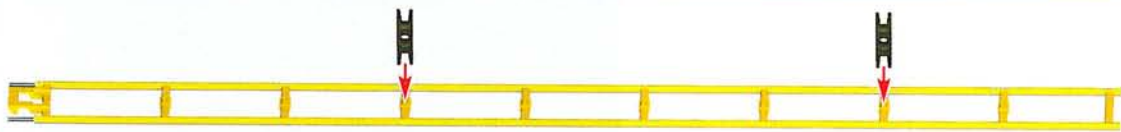

127

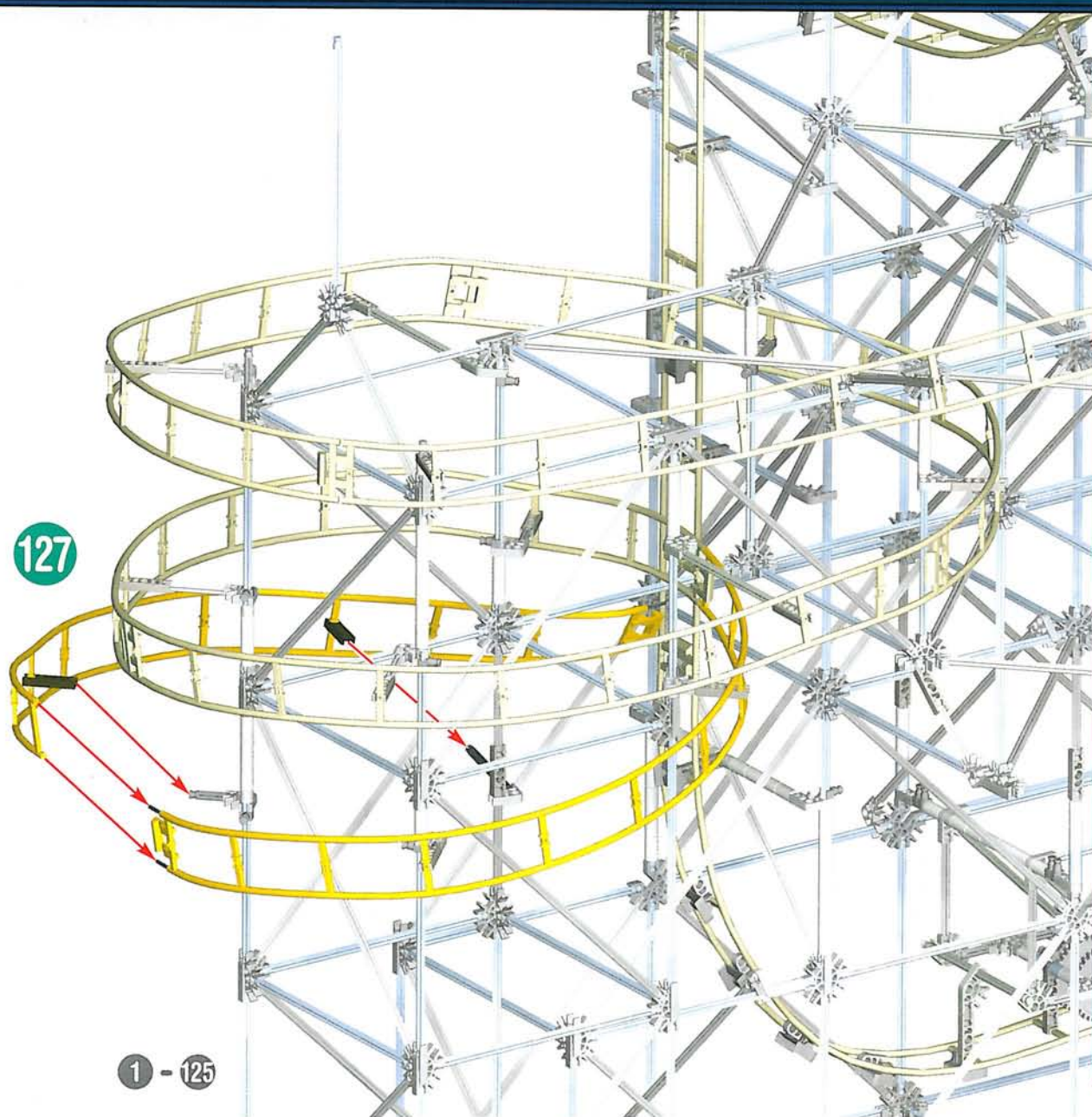

1 - 125

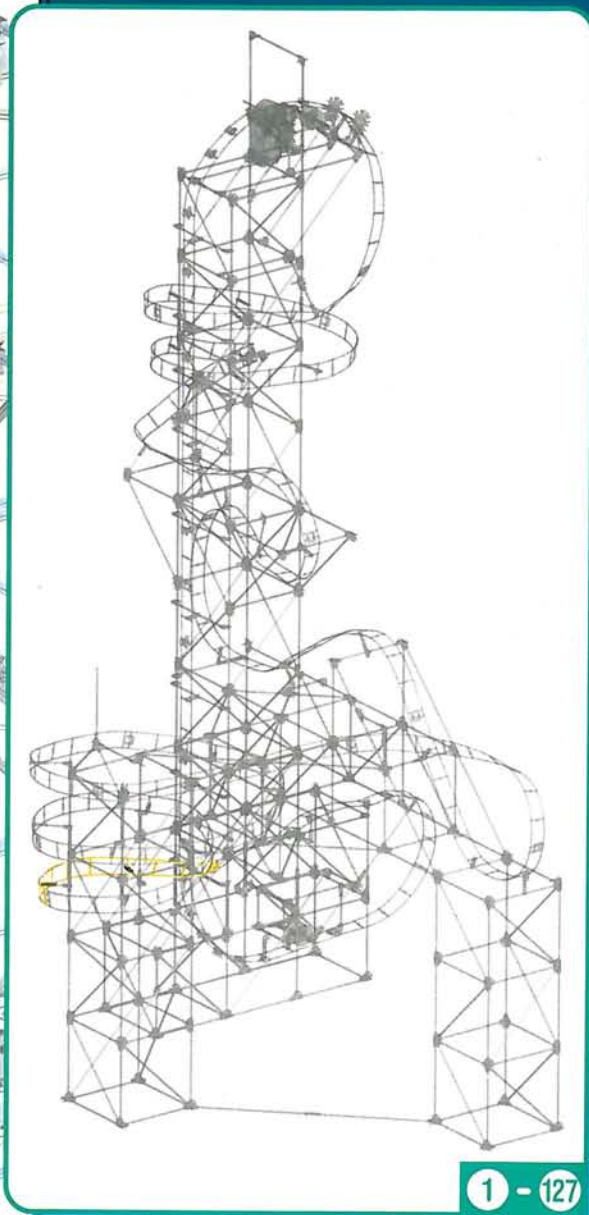

1 - 127

128

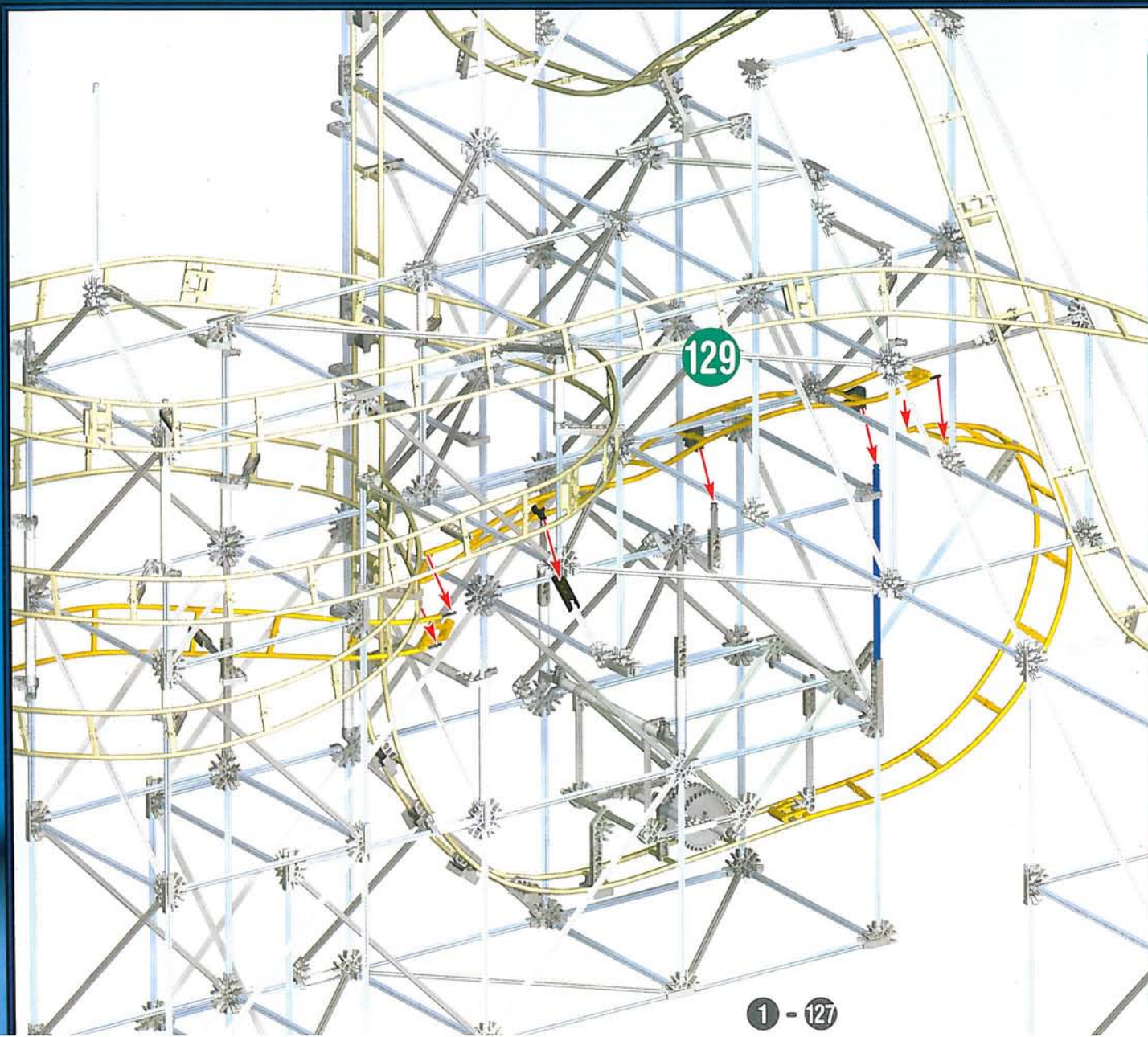
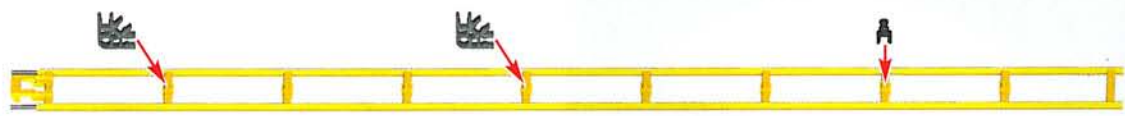

129

1 - 127

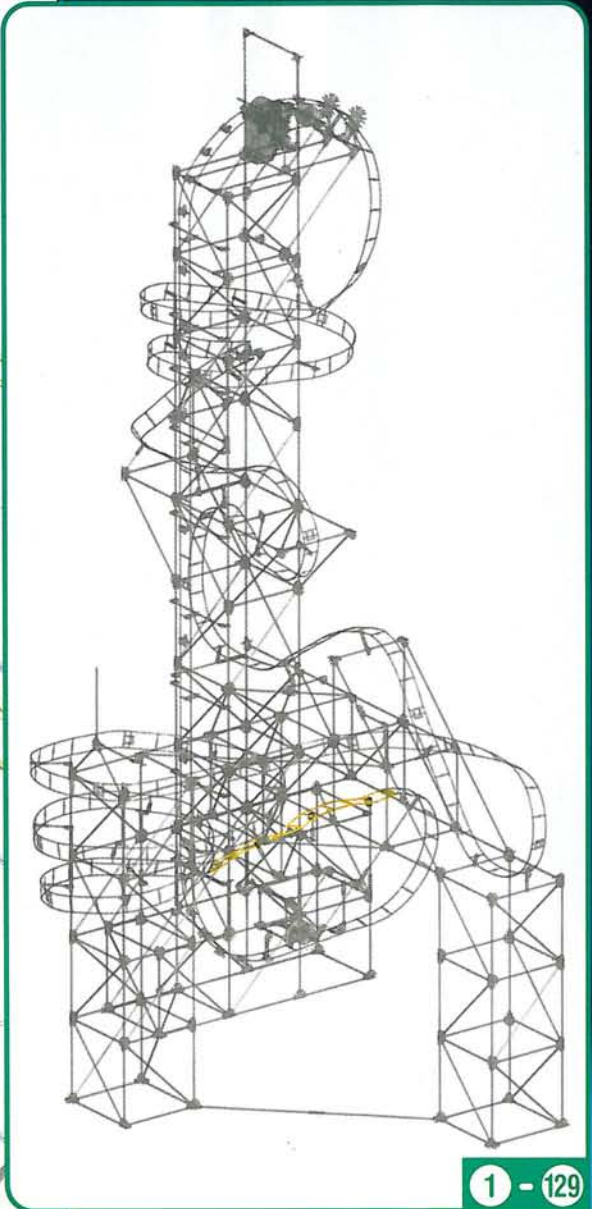

1 - 129

130



20x

131



1x

 10x

 11x

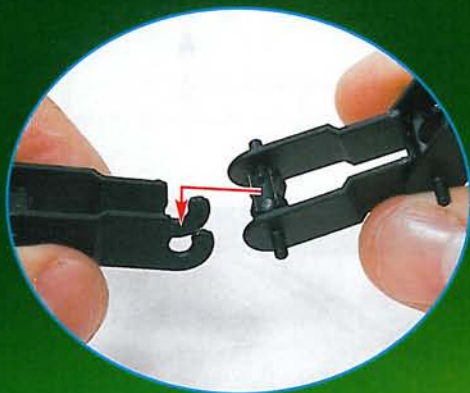

- (ENG) IMPORTANT: Attach all the Chain Links in the same direction.
- (F) IMPORTANT : Attache les chaînons dans le même sens.
- (E) IMPORTANTE: Conecta los Eslabones de la Cadena en la misma dirección.
- (D) WICHTIG: Befestige die Kettenglieder immer in die gleiche Richtung.
- (NL) BELANGRIJK: Maak de ketenschakels vast in dexelfde richting.
- (I) IMPORTANTE: Collegare le maglie della catena nella stessa direzione.
- (P) IMPORTANTE: Prende os Elos da Corrente seguindo a mesma direcção.

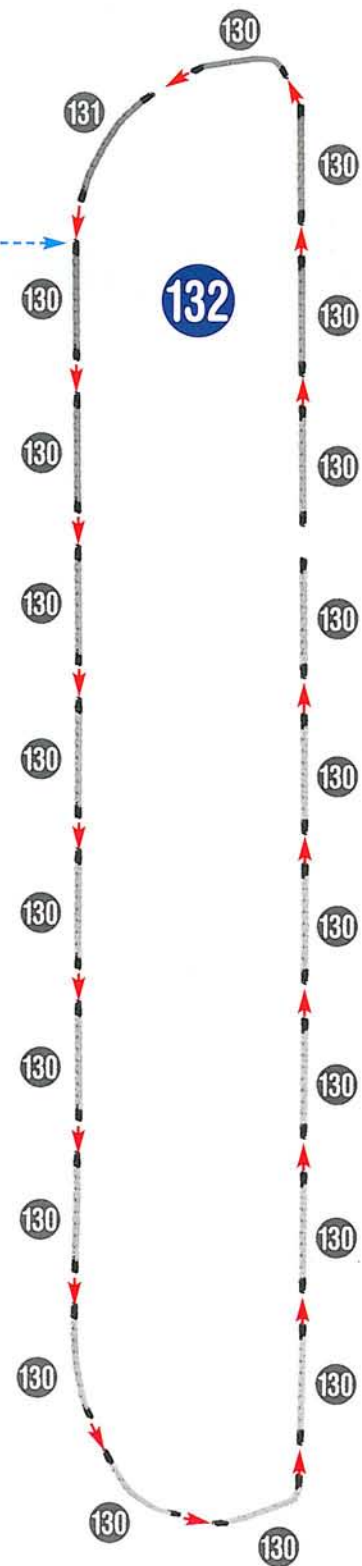



133

ENG The Chain must pass between the 2 gray Gears at the top and bottom of the tower. Make sure the Chain rides on the black Chain Guides.

F La chaîne doit passer entre les engrenages. Veille à ce que la chaîne soit bien alignée sur les guides de chaîne.

E La Cadena debe pasar entre los Engranajes. Asegúrate de que la cadena esté debidamente montada en las Guías de Cadena.

D Die Kette muss wischen dem Getriebe. Achte darauf, dass die Kette auf den Kettenführungen verläuft.

NL De keten moet tussen de versnellingsmechanismen. Verzeker je ervan dat de ketting op kettinggidsen loopt.

I La catena deve passare fra gli ingranaggi. Accertati che la catena giri sulle guide a catena.

P A Corrente dever passar entre as Engrenagens. Assegura-te de que a Corrente é montada nas respectivas Guias.

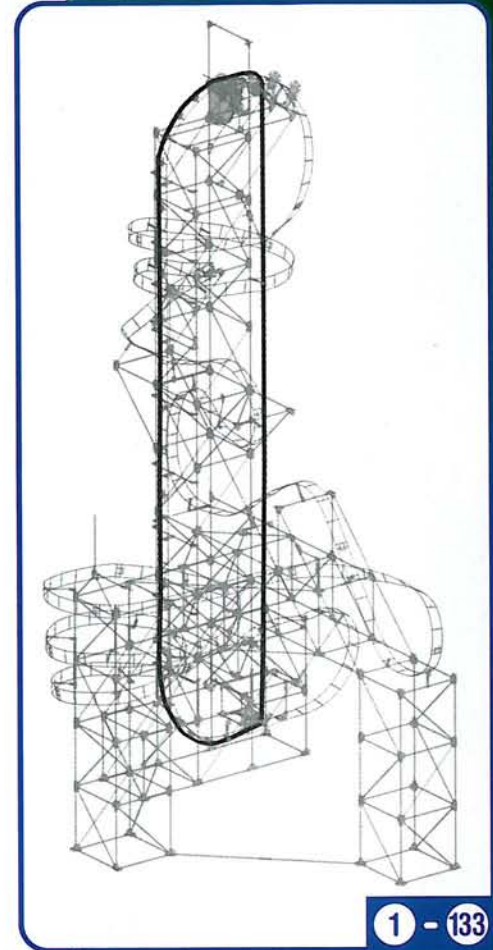
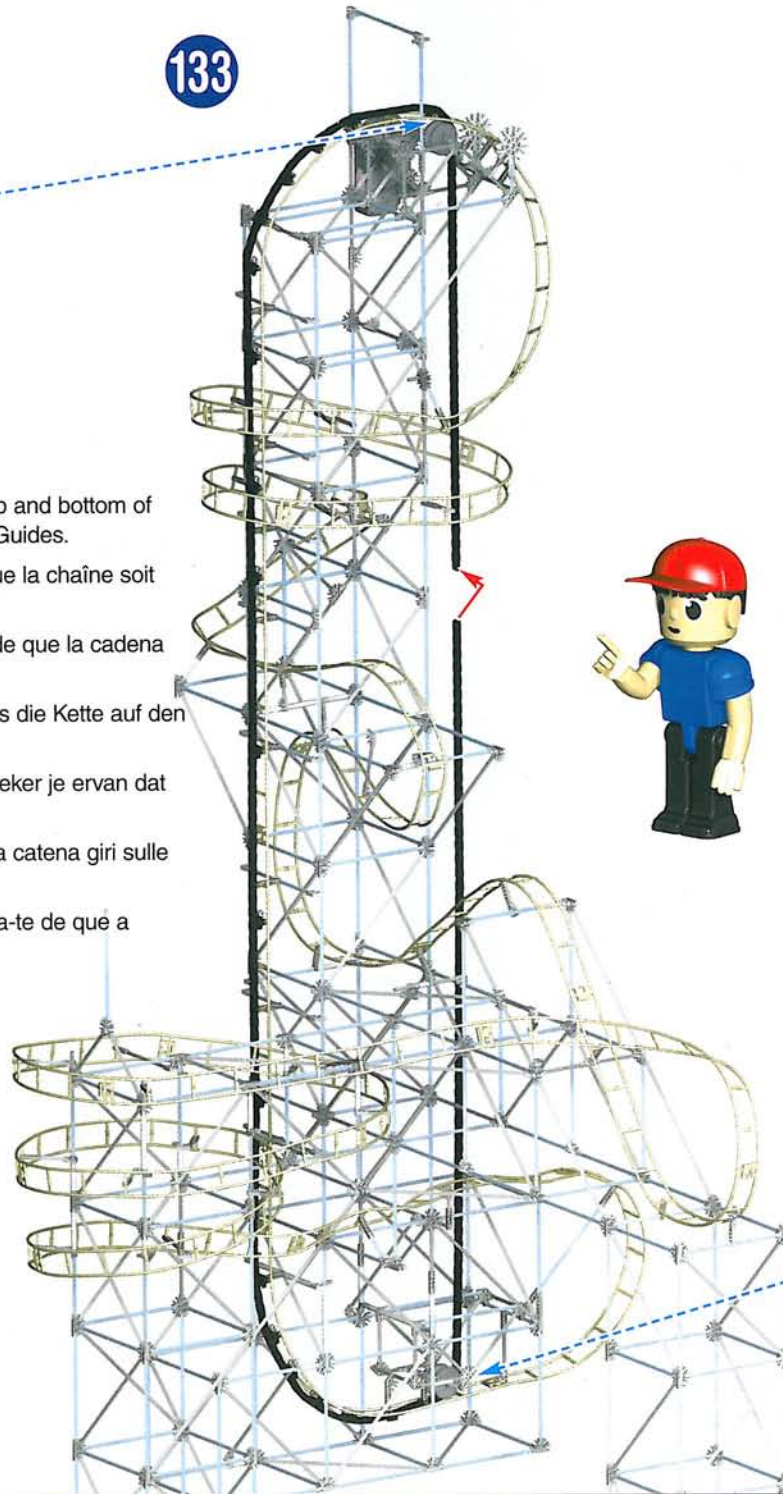
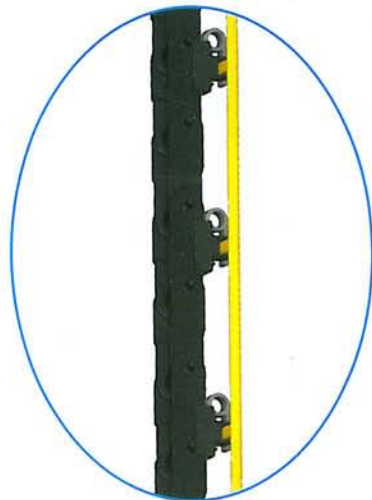

1 - 133



1 - 132

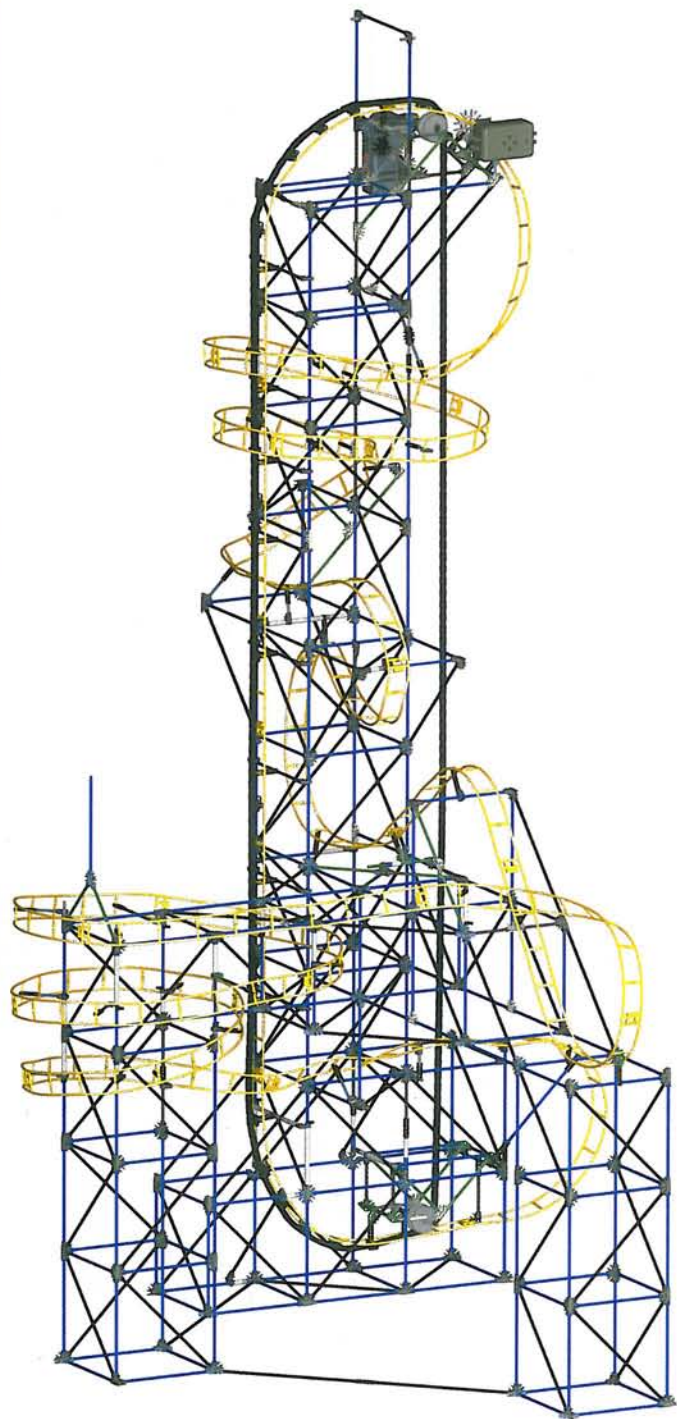

- The Sound Module may not work properly in direct sunlight.
- The Sound Module's sensor detects the Car's motion.
- Make sure the sensor is aligned with and facing the Reflective Sticker.
- Push the gray button on the side to activate sound. The Sound Module will shut off after 10 minutes. Push the button again to reactivate the sound.

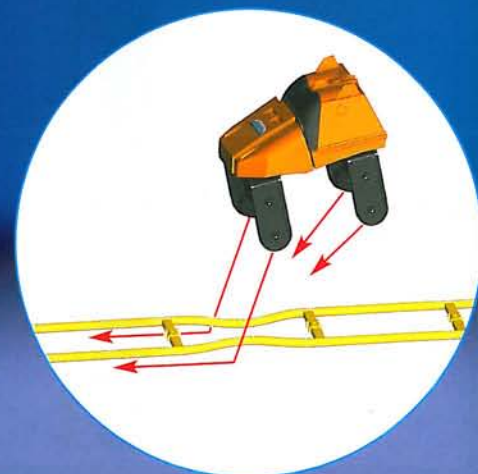
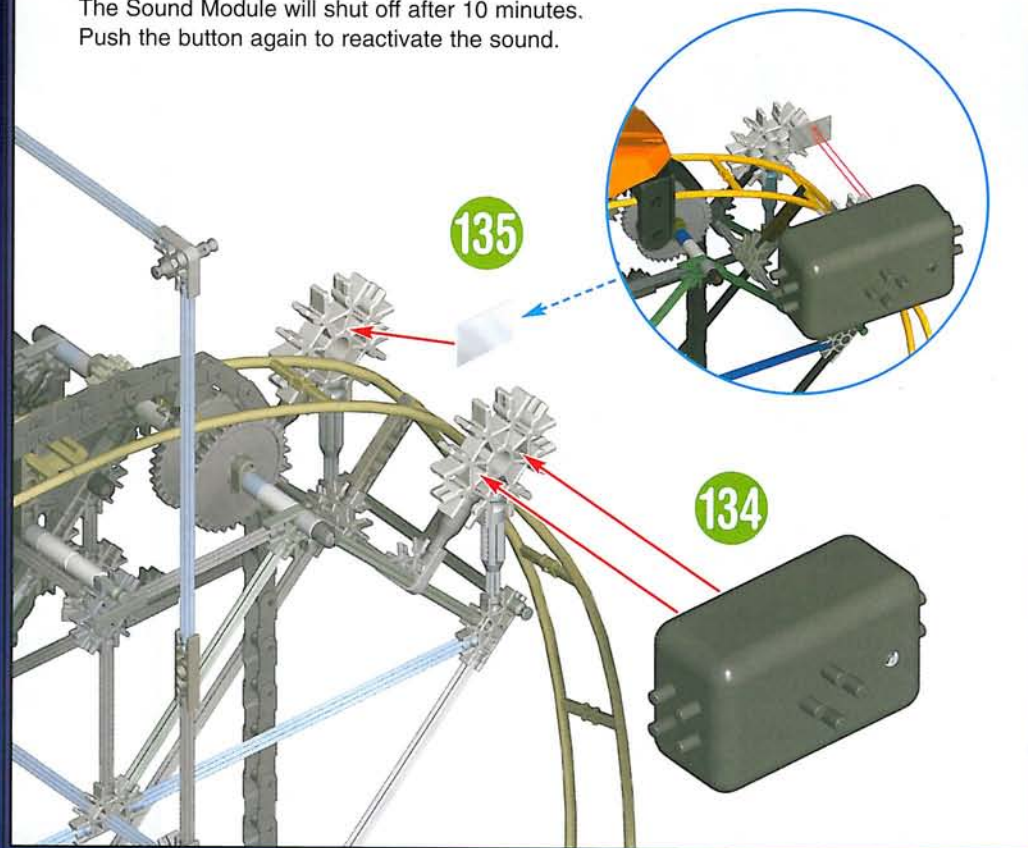

ENG To attach the Cars, squeeze the Track slightly and hook the wheels on the Track. If Cars get stuck on the way down. Make sure the Car is not hitting any K'NEX parts. Are the Track pieces connected properly? Adjust the Track to eliminate any flat spots on the Track.

F Pour fixer les voitures, pince légèrement le circuit et fixe les roues dessus. Si des voitures restent coincées au cours de la descente. Vérifie que la voiture ne heurte pas des pièces K'NEX. Est-ce que les pièces du circuit sont connectées comme il faut ? Est-ce que la voiture est fixée au circuit comme il faut ? Ajuste le circuit de façon à y éliminer des endroits plats.

E Para sujetar los Coches, aprieta la Pista levemente y engancha las ruedas en la Pista. Si los coches quedan atascados mientras van hacia abajo. Asegúrate de que el coche no esté golpeando ninguna de las piezas K'NEX. ¿Las piezas de la Pista están conectadas correctamente? Ajusta la Pista para eliminar cualquier lugar plano que le encuentres.

D Die Wagen werden aufgesetzt, indem die Schienen leicht zusammengedrückt und die Räder dann in die Schiene eingehängt werden. Falls die Wagen bei der Abfahrt stecken bleiben. Überprüfe ob der Wagen gegen einzelne Bauteile stößt. Sind die Schienenstücke richtig miteinander verbunden? Ändere den Schienenverlauf so, dass die Wagen immer genügend Schwung haben.

NL Om de wagens vast te maken, knijp lichtjes aan het spoor en haak de wielen op het spoor vast. Wanneer wagens vastlopen tijdens de daling. Verzeker je ervan dat de wagen tegen geen K'NEX onderdelen aanloopt. Zijn de spoorstukken behoorlijk verbonden? Adjusteer het spoor om platte stukken op het spoor te verwijderen.

I Accertati che la catena giri sulle guide a catena. Se le carrozze si arrestano durante la discesa. Controlla che la carrozza non abbia colpito qualche altra parte K'NEX. I pezzi della rotaia sono collegati correttamente? Regola la rotaia per eliminare qualsiasi parte piatta sulla stessa.

P Assegura-te de que a Corrente é montada nas respectivas Guias. Se as Carruagens ficarem encravadas na descida. Assegura-te de que a Carruagem não está a chocar contra outras peças K'NEX. As peças da Pista estão ligadas correctamente? Ajusta a Pista para eliminares qualquer ponto plano na Pista.

TIPS & TROUBLESHOOTING

If Motor and/or Sound Module are not working:

- Check to see if you have fresh batteries and that they are installed correctly.
- If it is still not working, call our Consumer Hotline at 1-800-KID-KNEX (USA and Canada only). See the back cover for other ways to contact K'NEX Industries, Inc.

If Cars get stuck on the way down:

- Is the model built correctly?
- Make sure the Car is not hitting any K'NEX parts.
- Are the Track pieces connected properly?
- Is the Car attached to the Track correctly?
- Adjust the Track to eliminate any flat spots on the Track.

Need additional building help?

- Go to the K'NEX web site: www.knex.com/tips

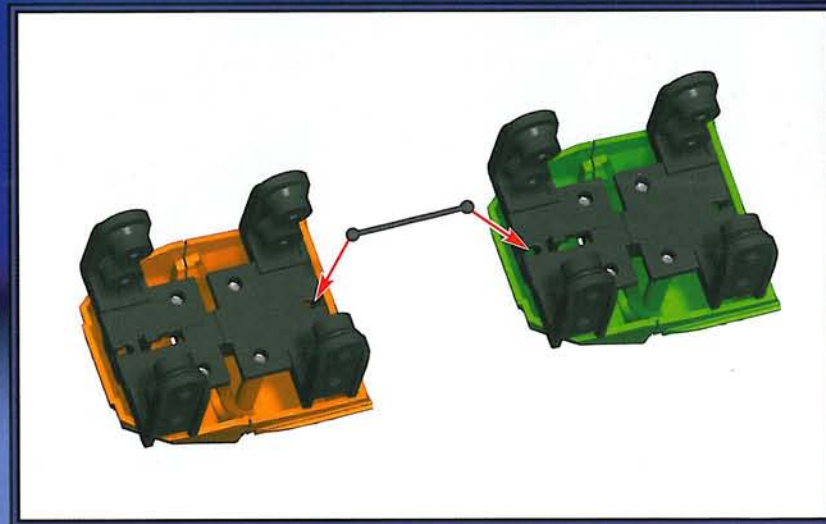



137

10x



141

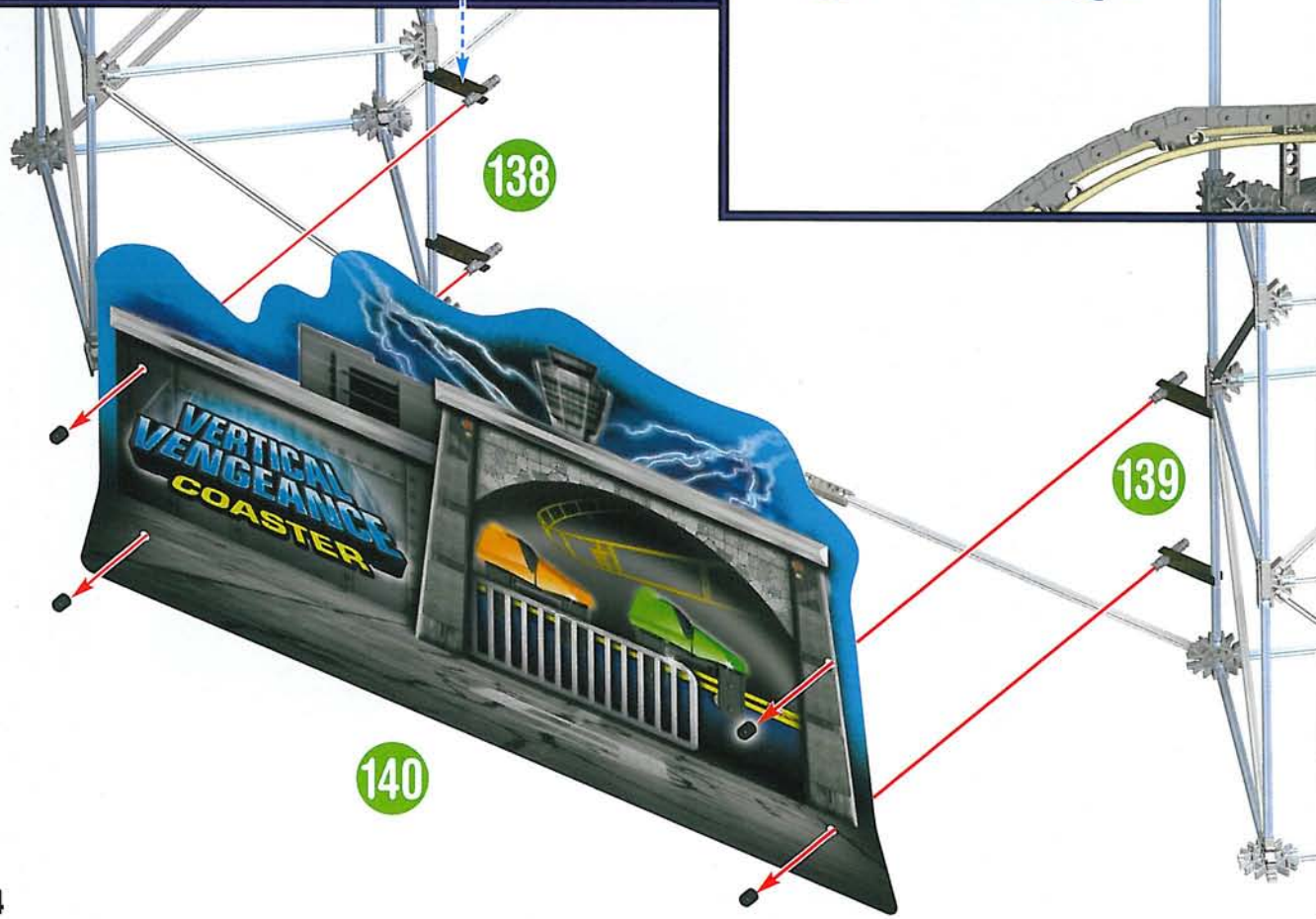

138

139

140



142

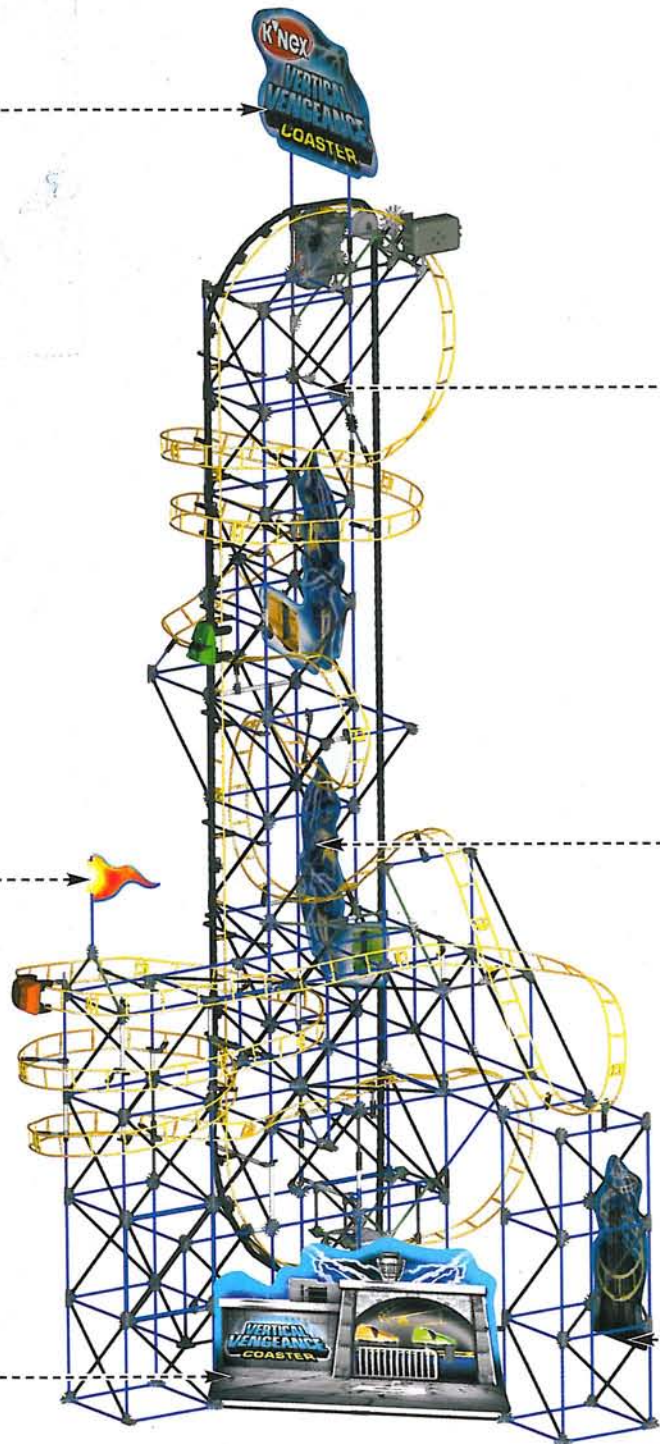

1 - 142

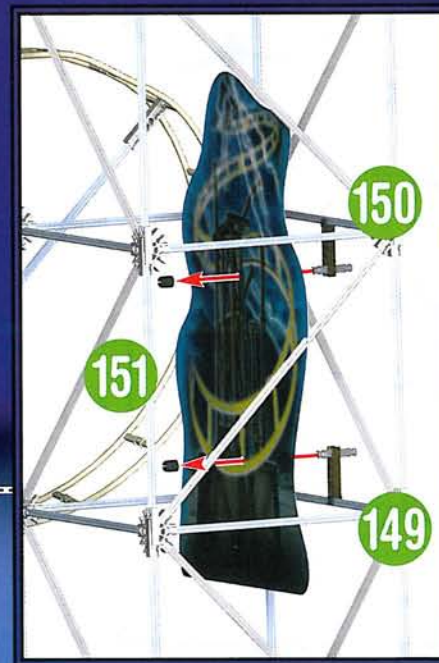
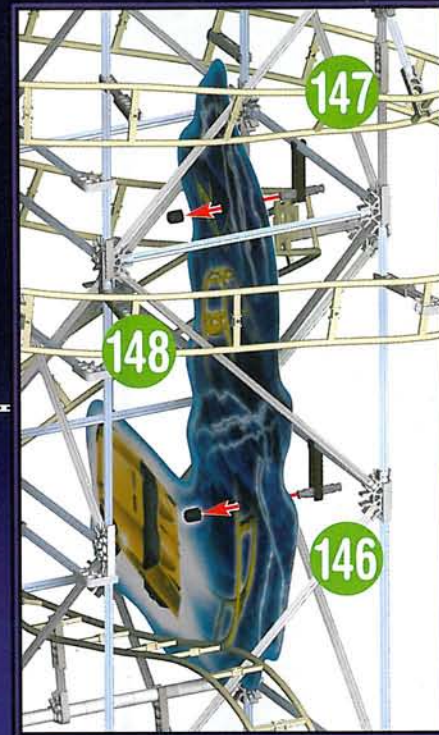
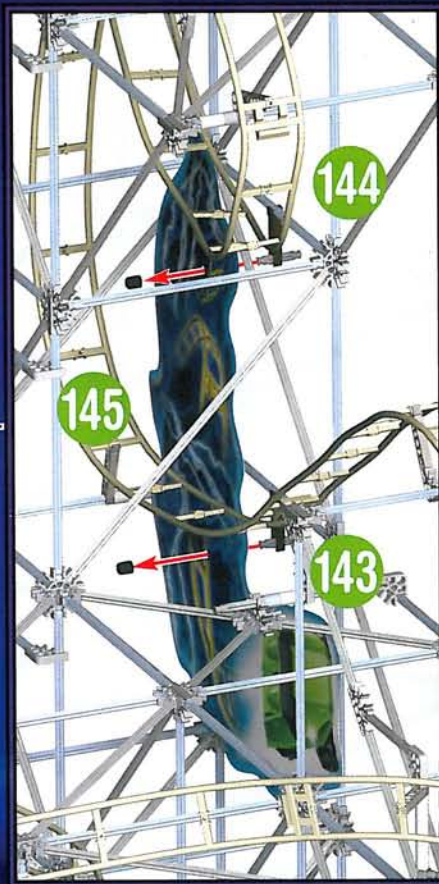

ALTERNATE COASTER: (INTERMEDIATE BUILD)

TOWER 1

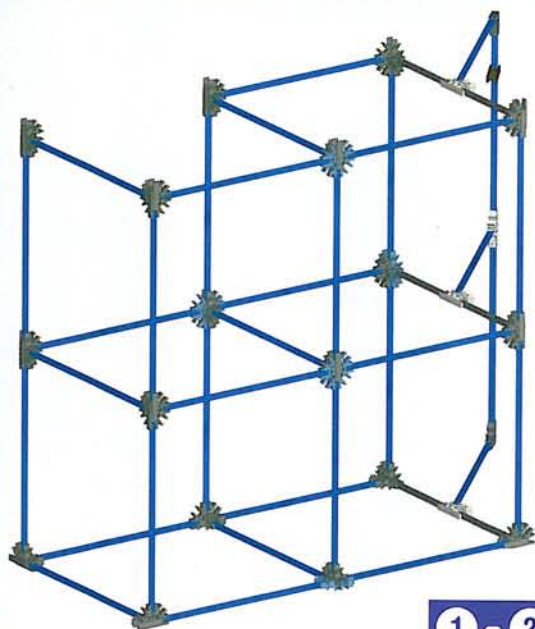
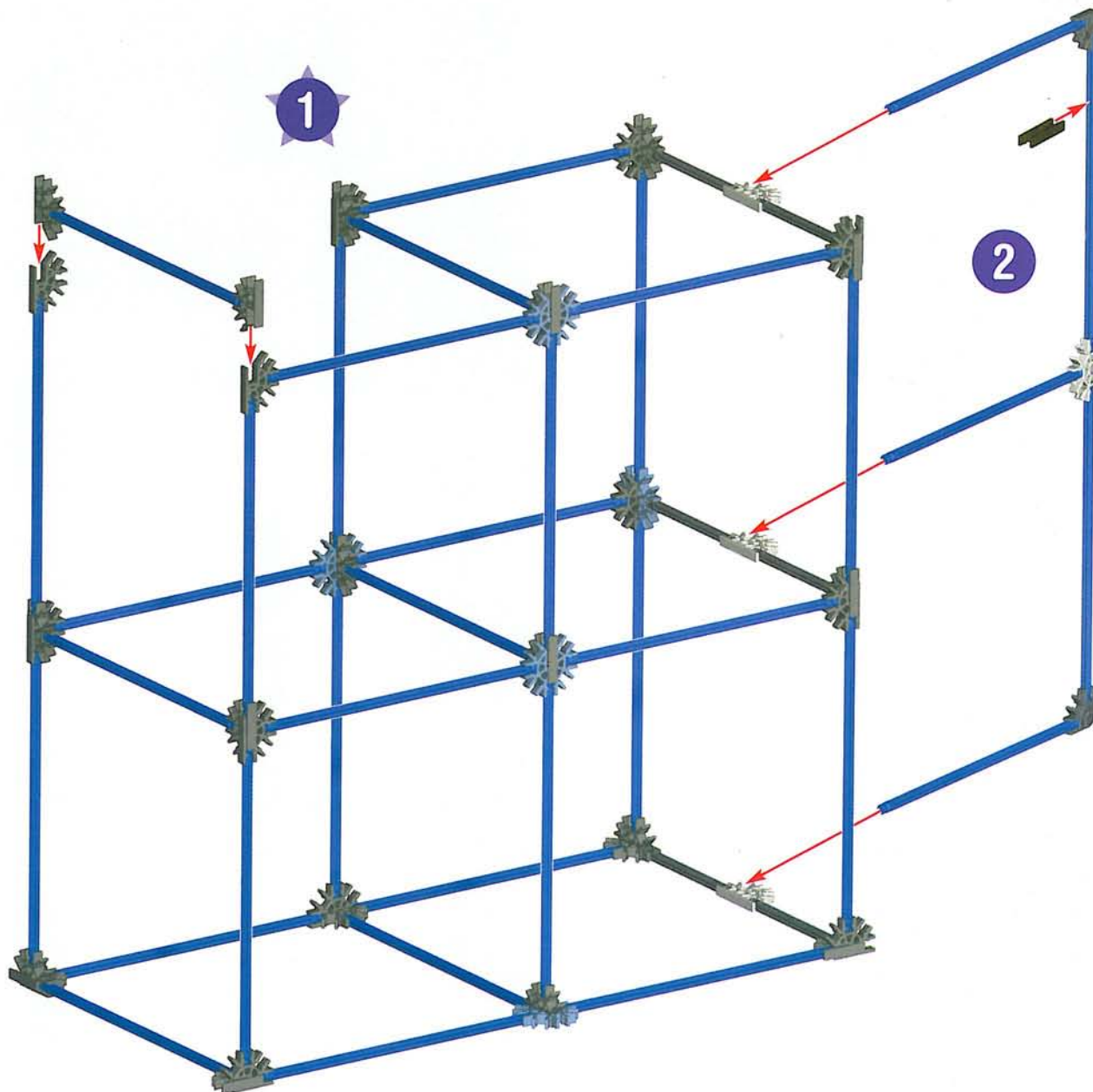
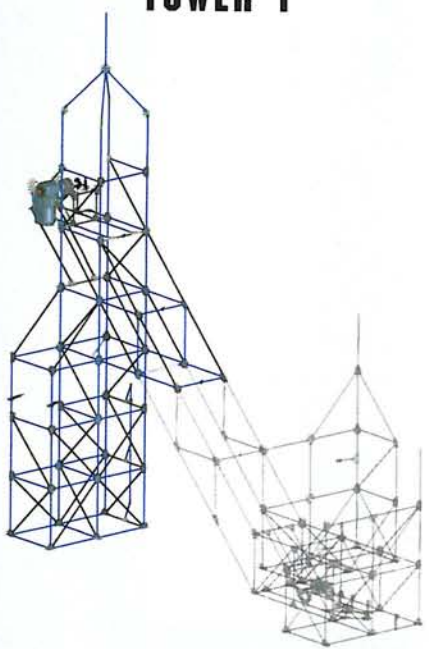

1 - 2

- (ENG) Be sure to position the blue and silver Connectors exactly as shown.
- (F) Veille à placer les connecteurs bleu et argent exactement comme l'indique le schéma.
- (E) Asegúrate de que colocas los conectores azules y plateados exactamente como se muestran.
- (D) Befestige die blauen und silbernen Verbindungsstücke genau so wie auf der Abbildung gezeigt.
- (NL) Verzeker je ervan om de blauwe en zilveren koppelstukken precies aan te brengen zoals afgebeeld.
- (I) Posiziona i connettori blu e argento esattamente come illustrato.
- (P) Certificare de que posicionas os Conectores azul e prata exactamente conforme indicado.

6x

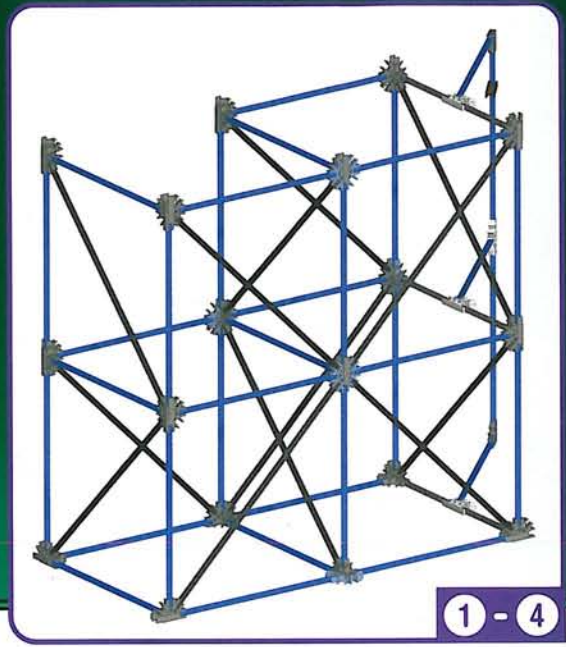
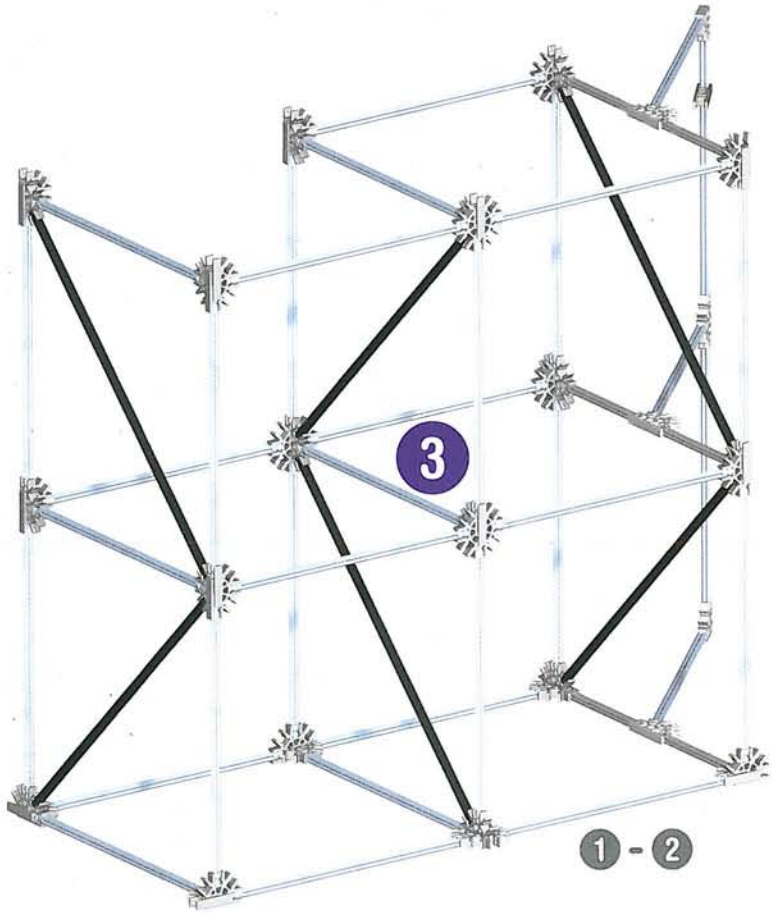

7x

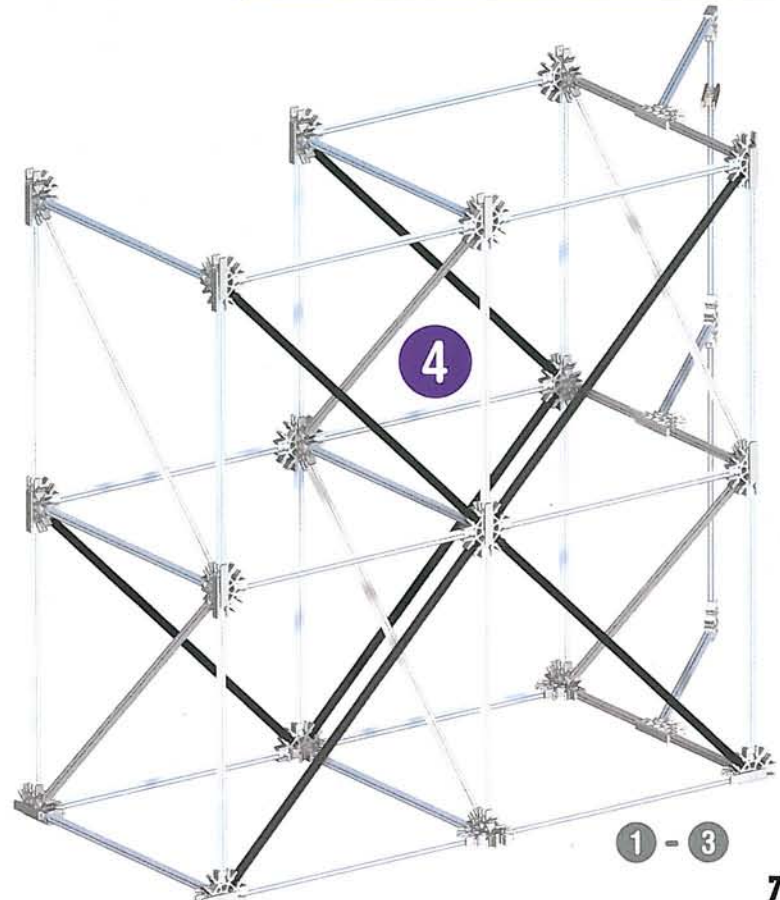

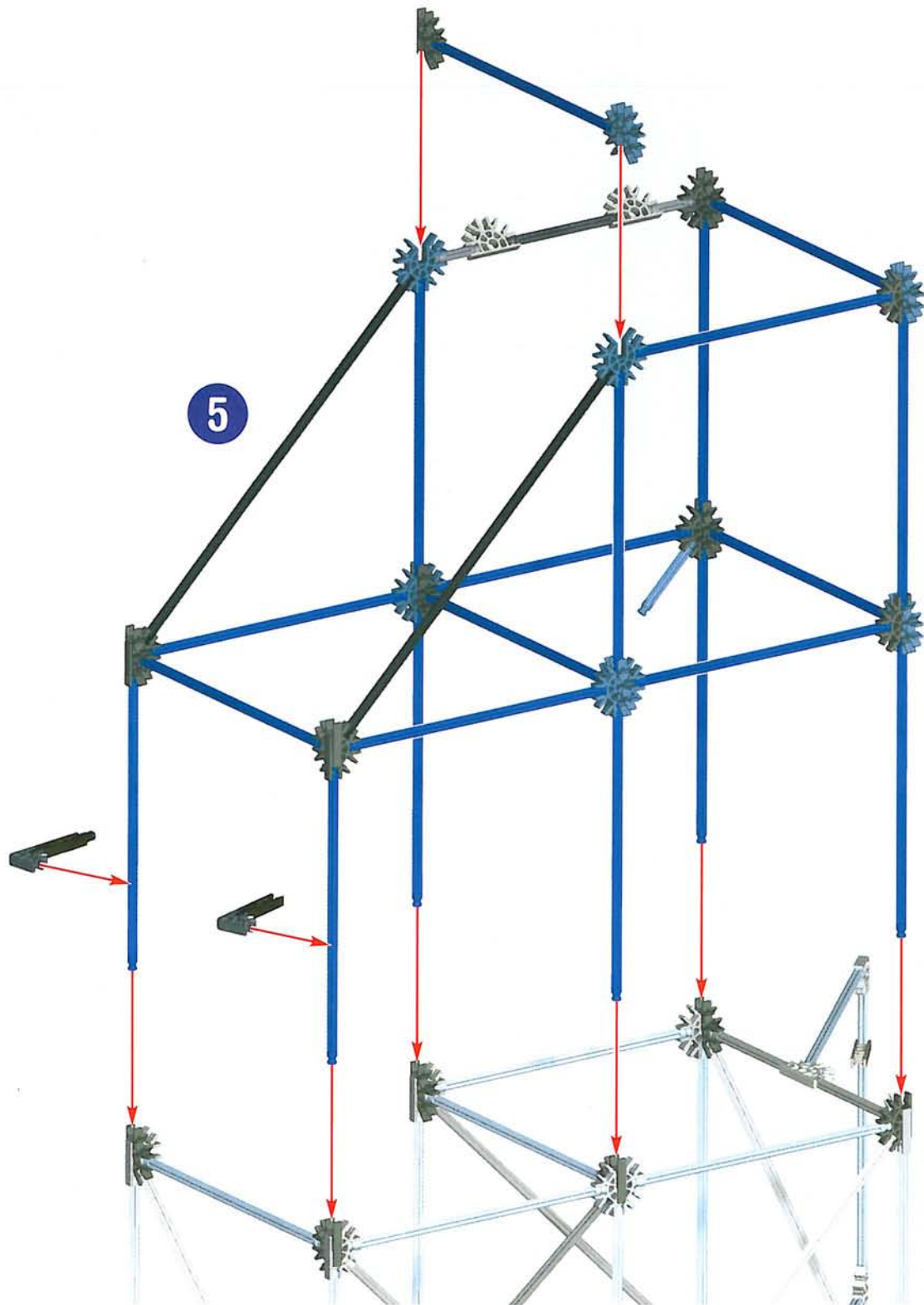

5

1 - 4

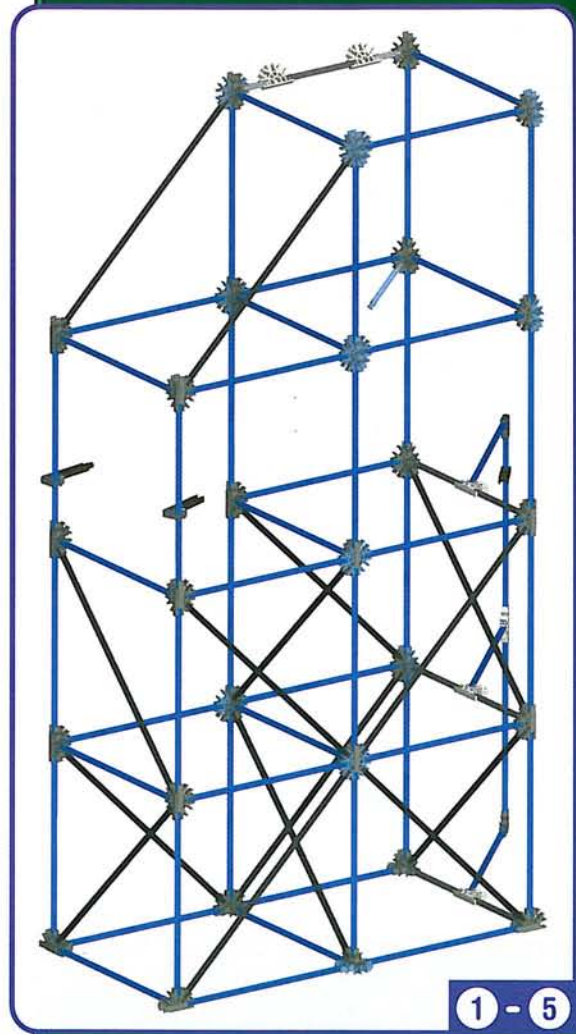

1 - 5

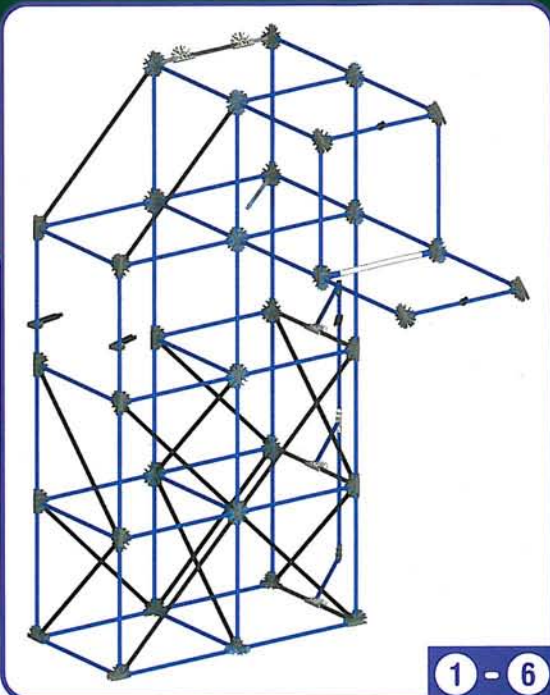
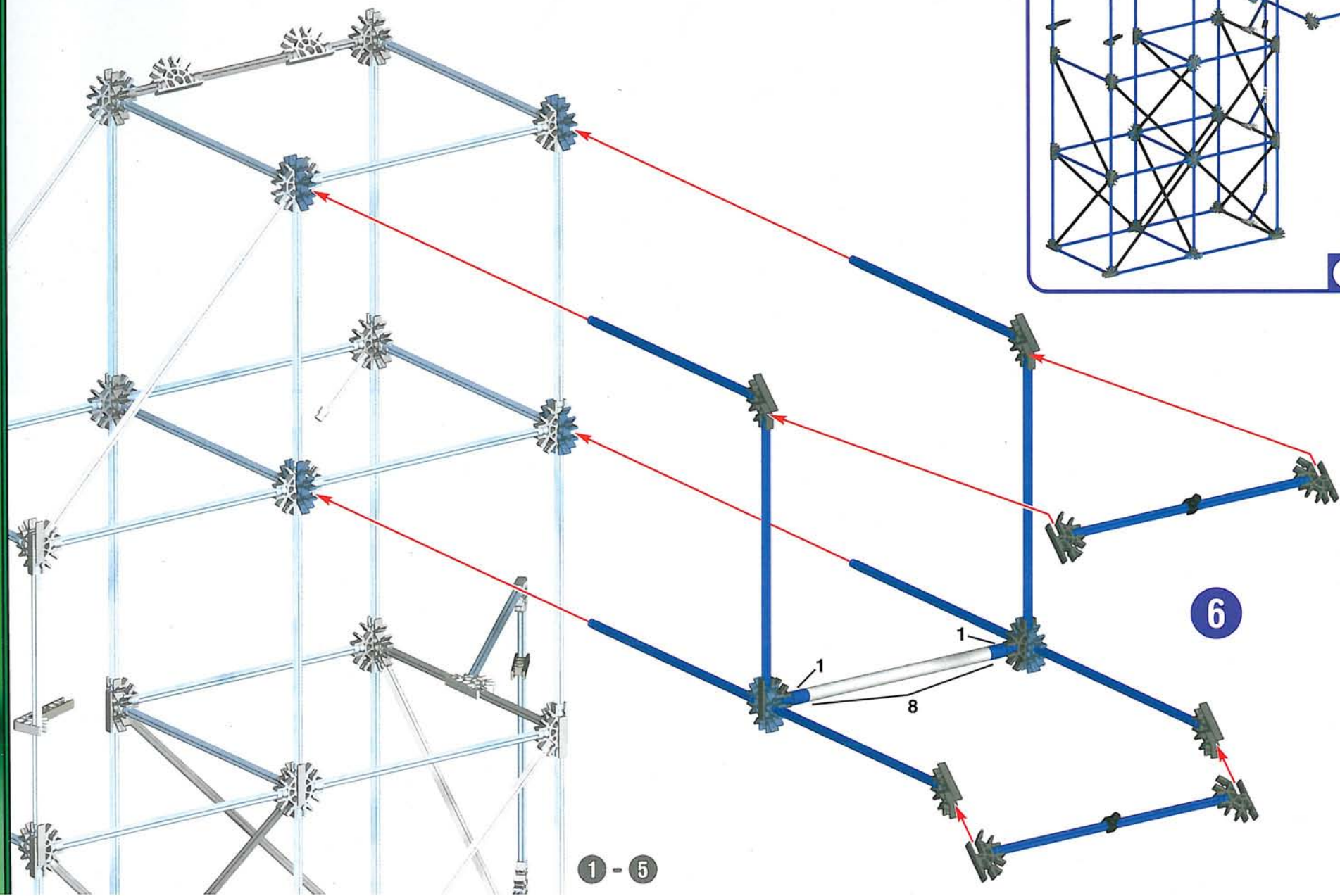

6

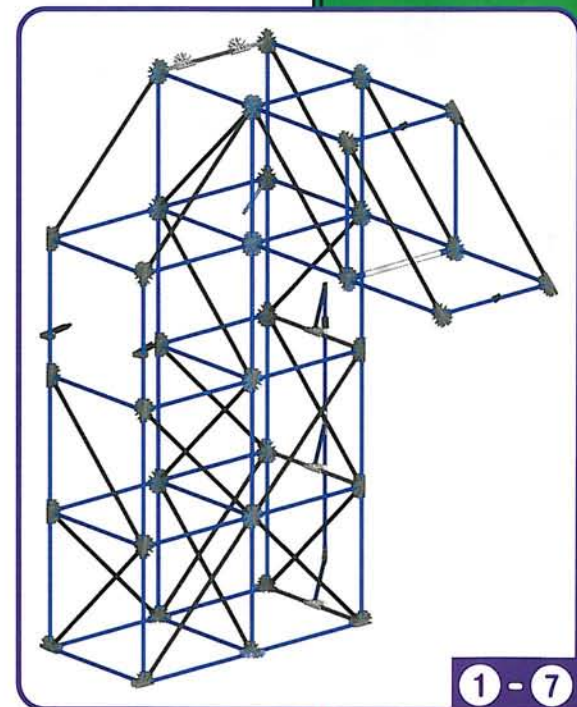
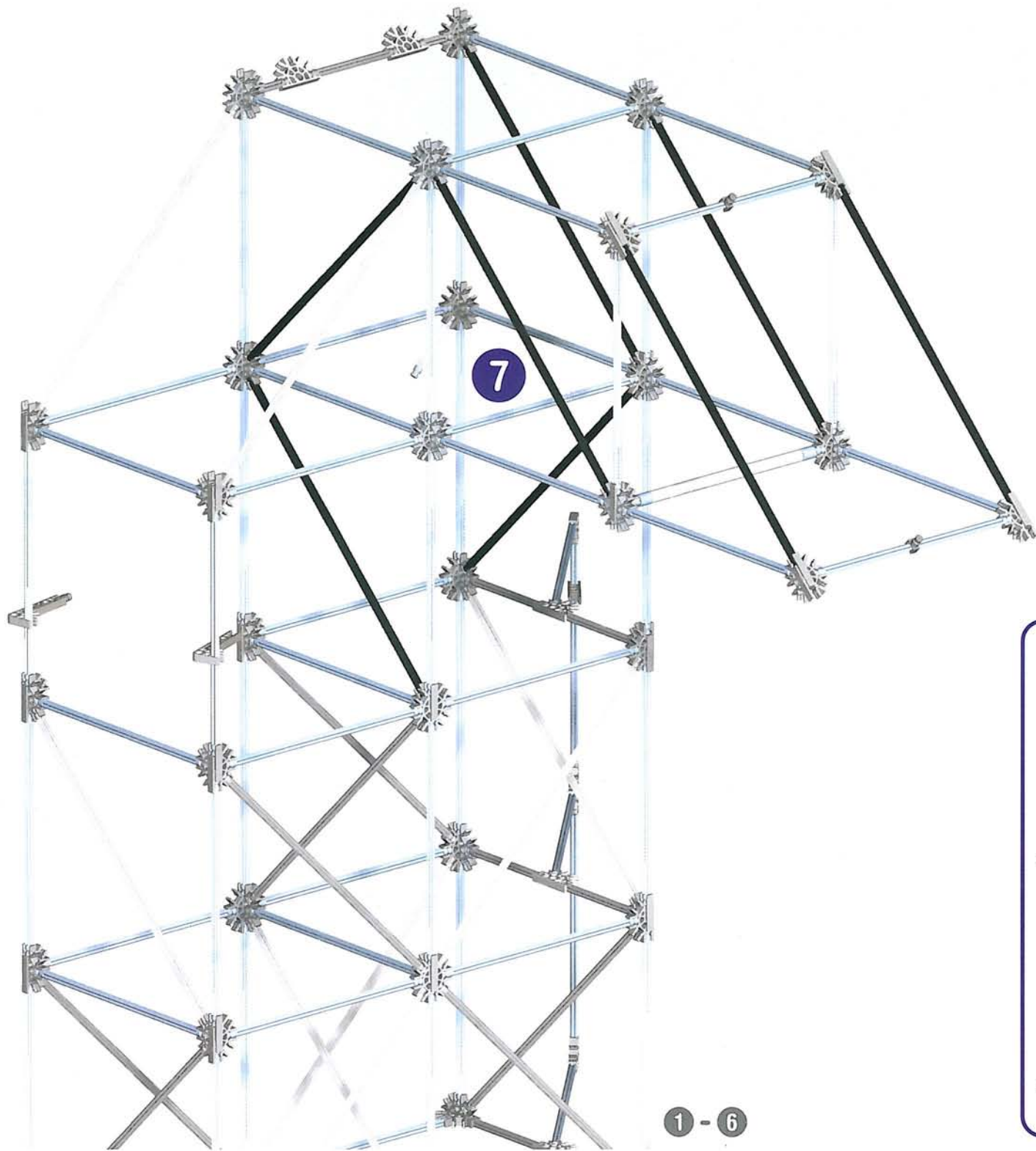

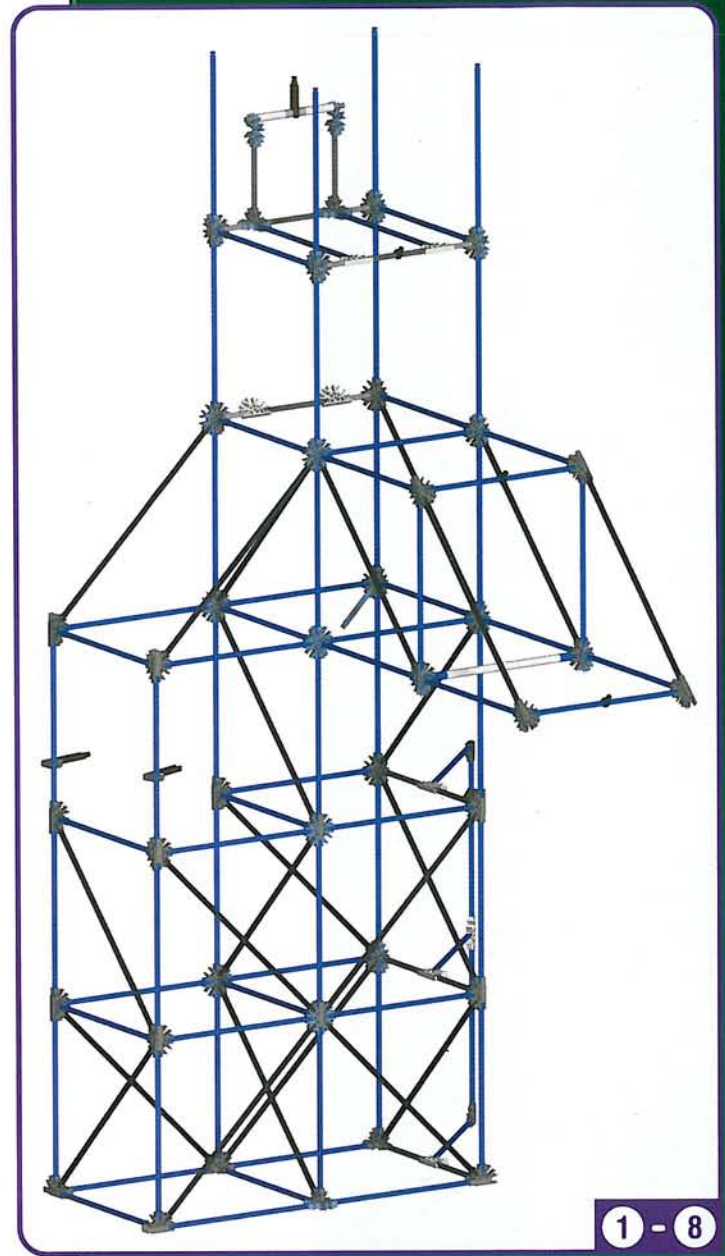
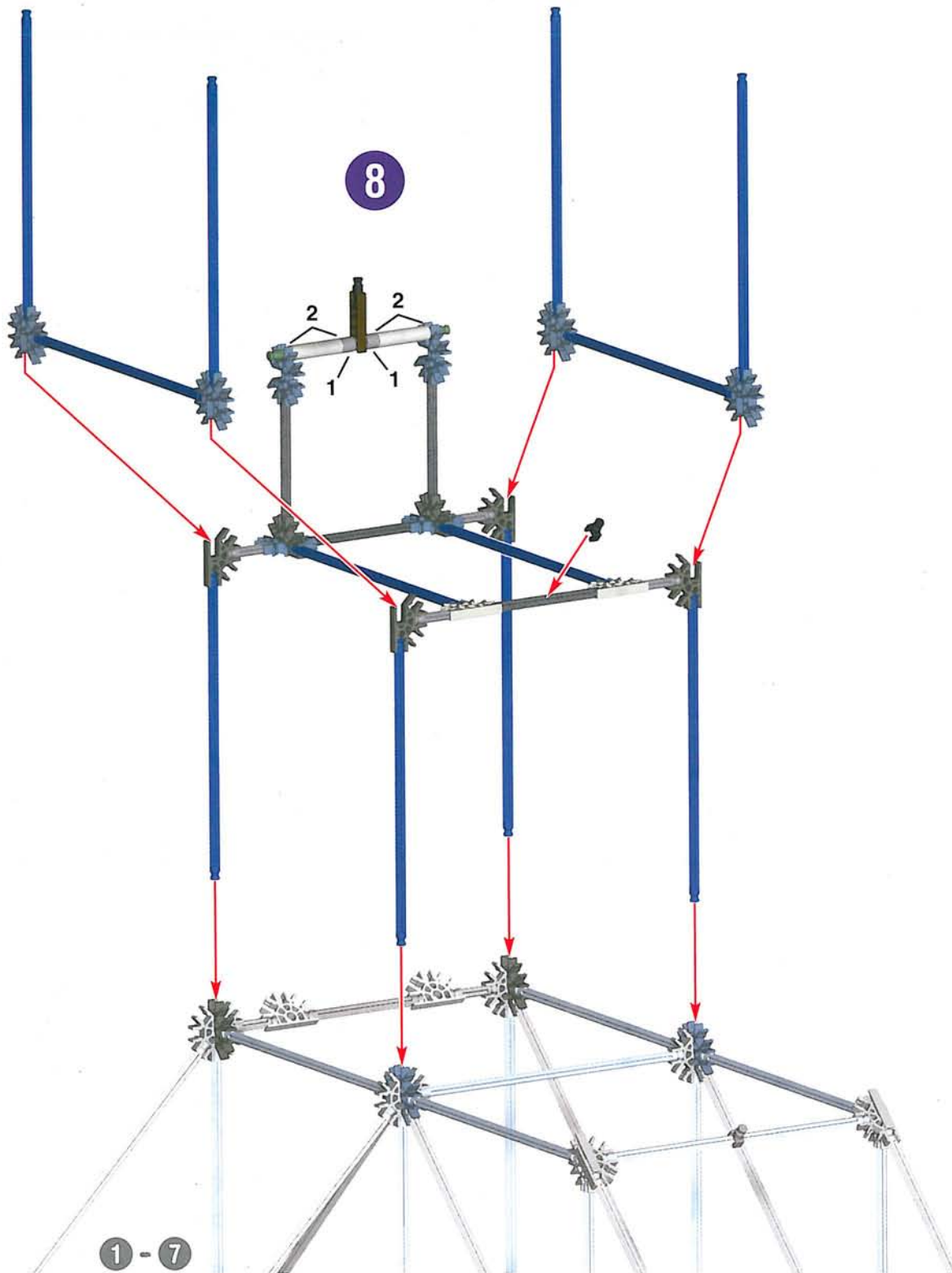

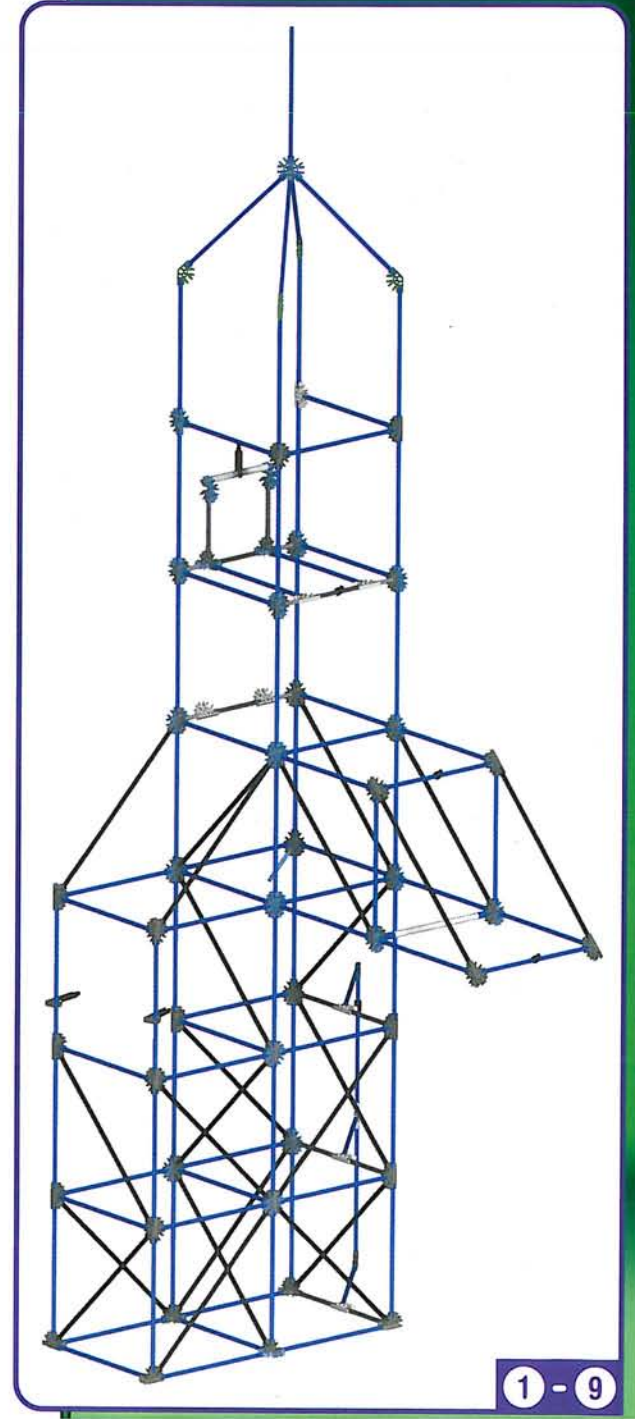
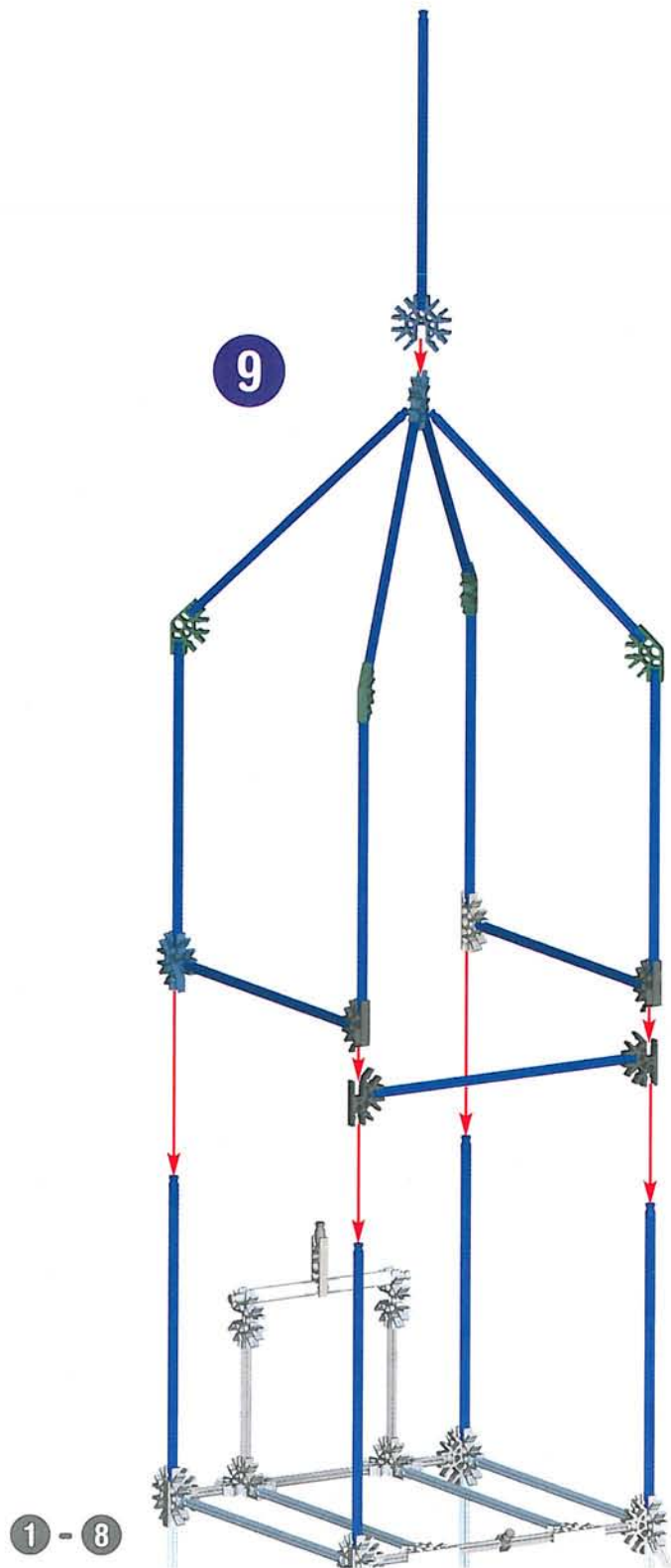

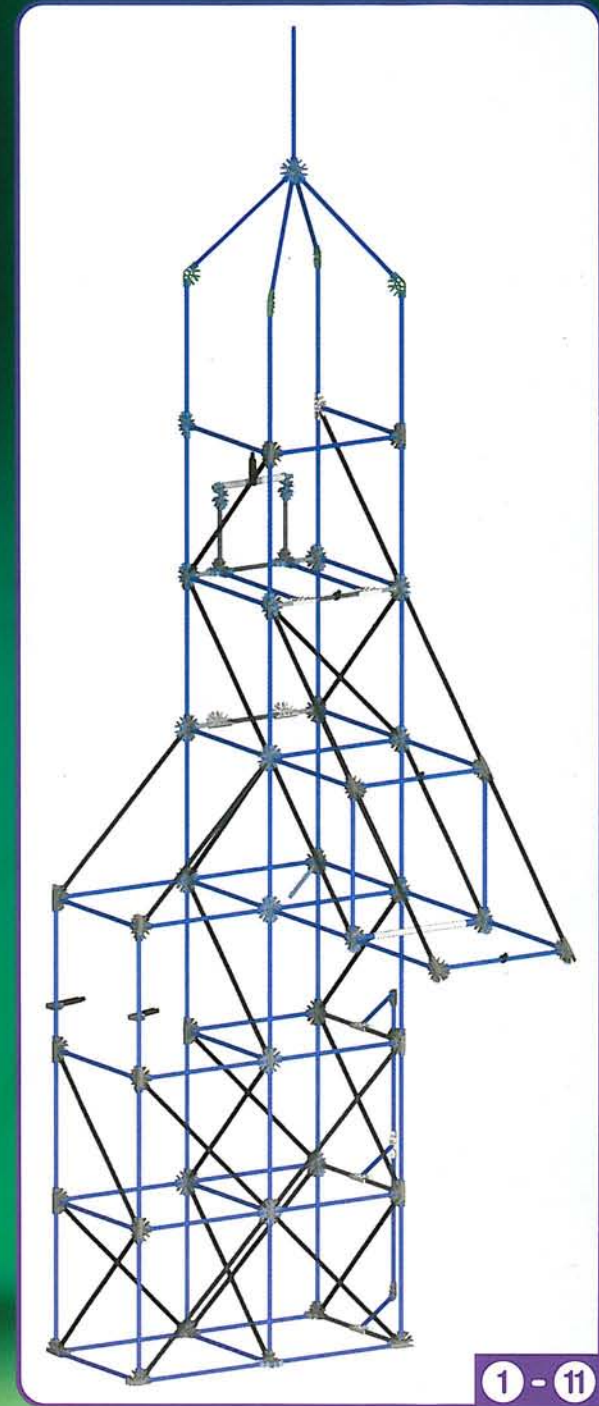
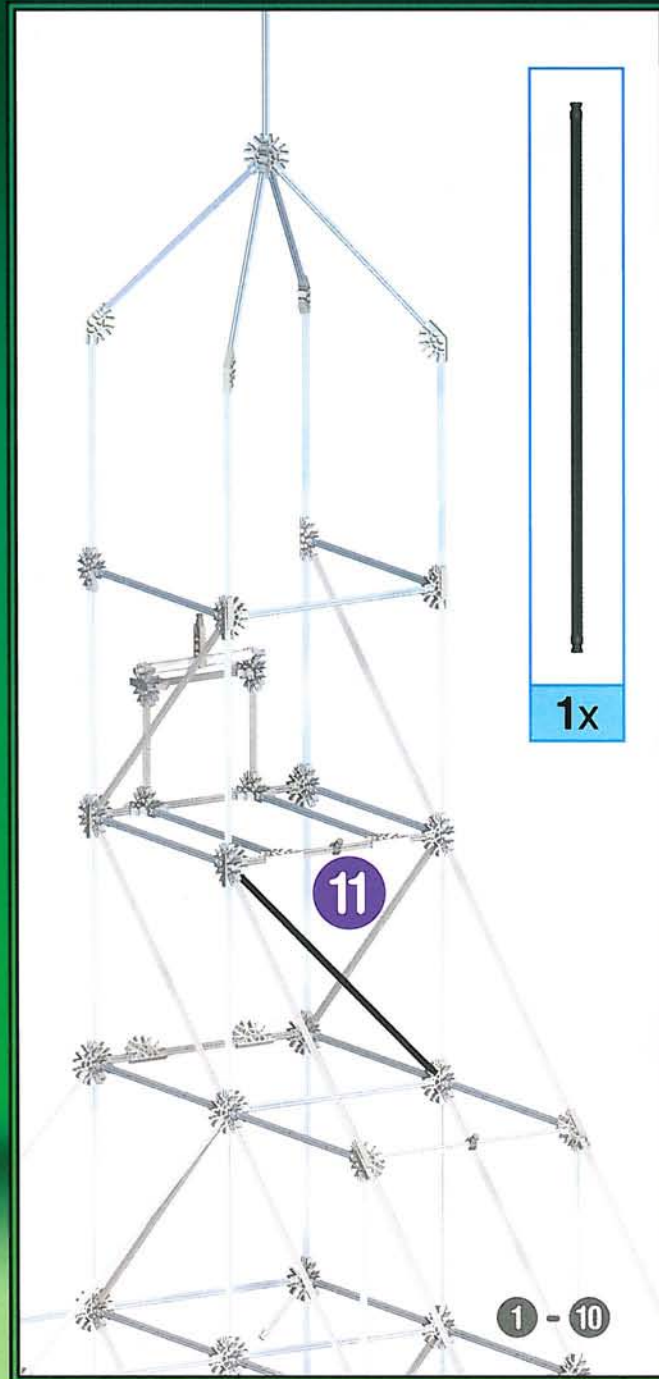
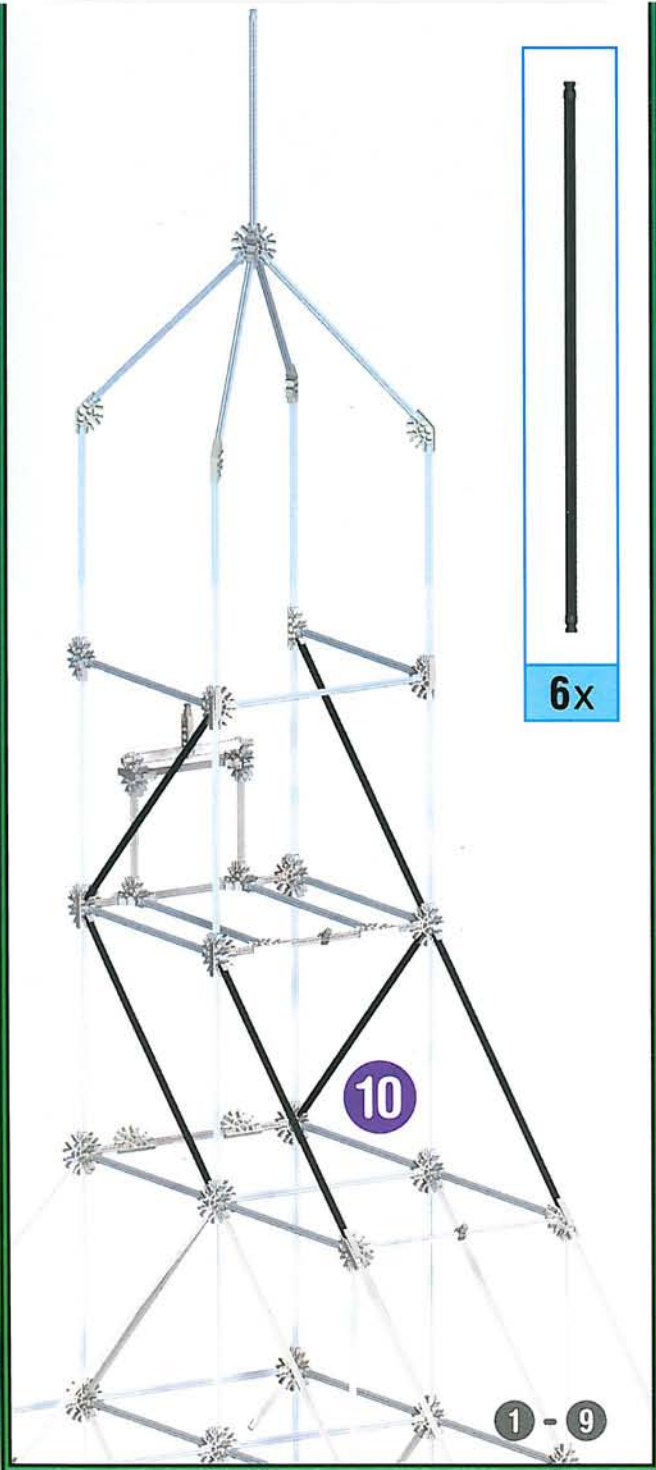

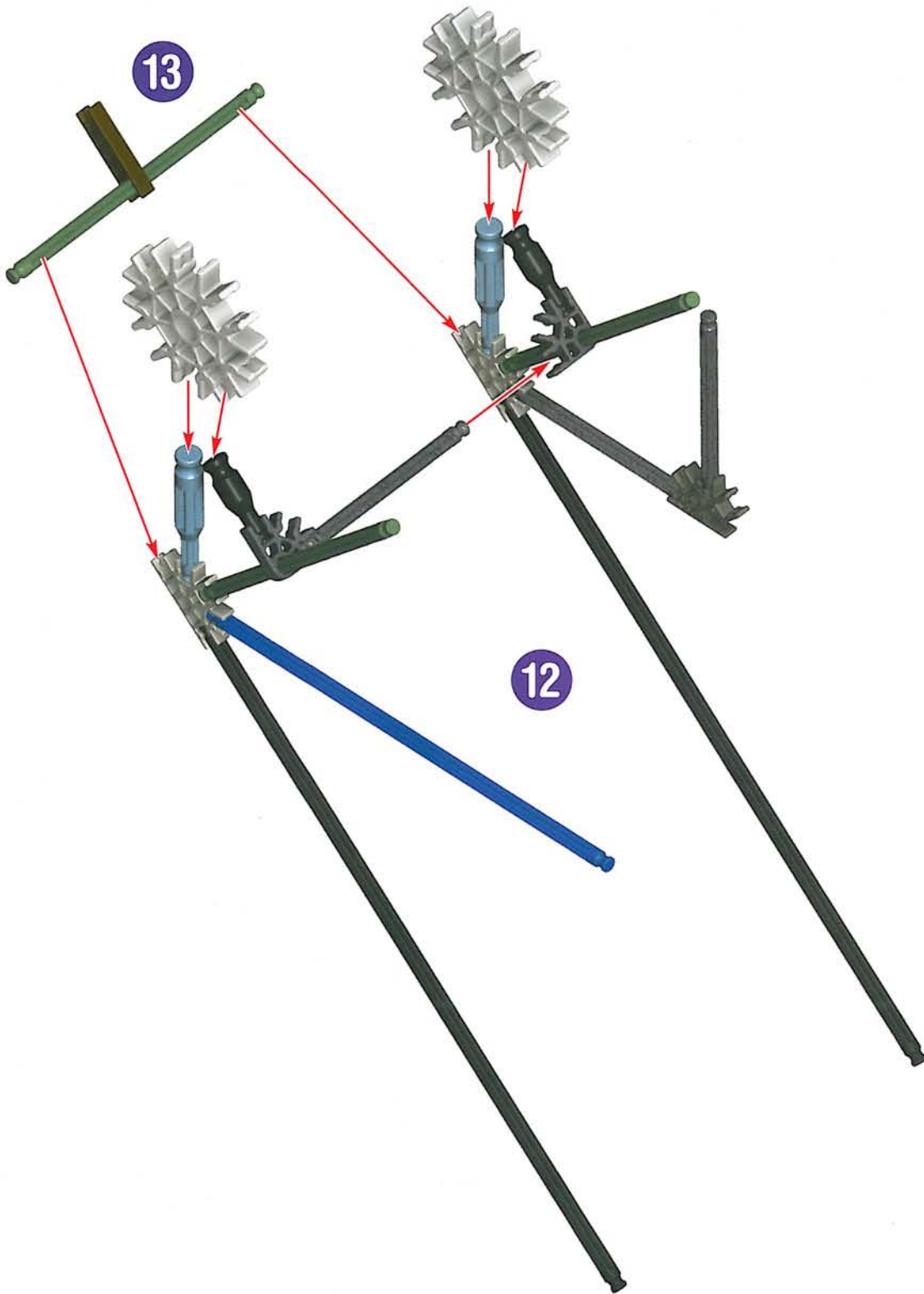

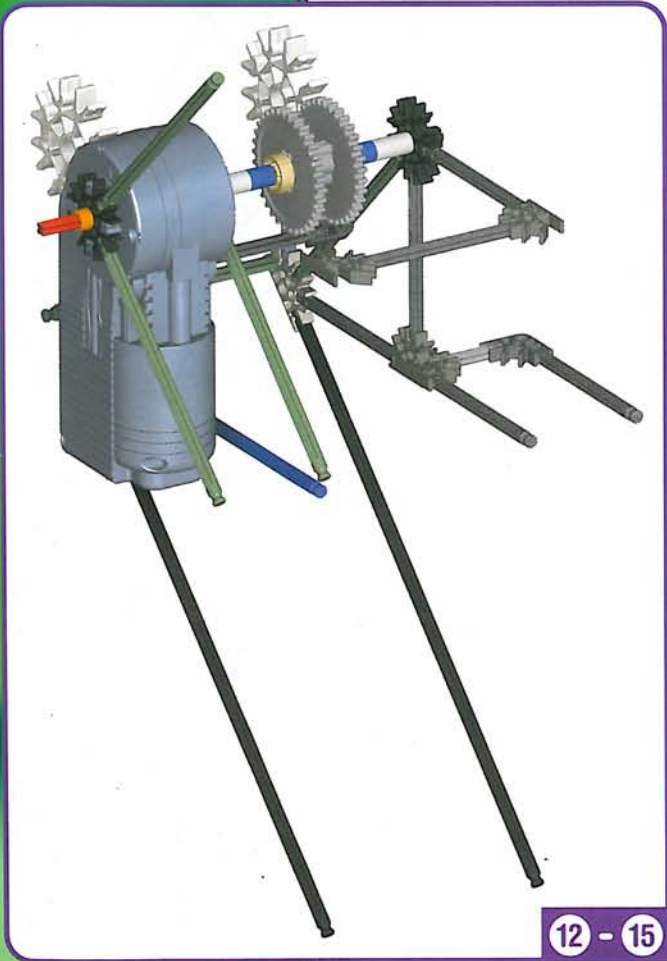
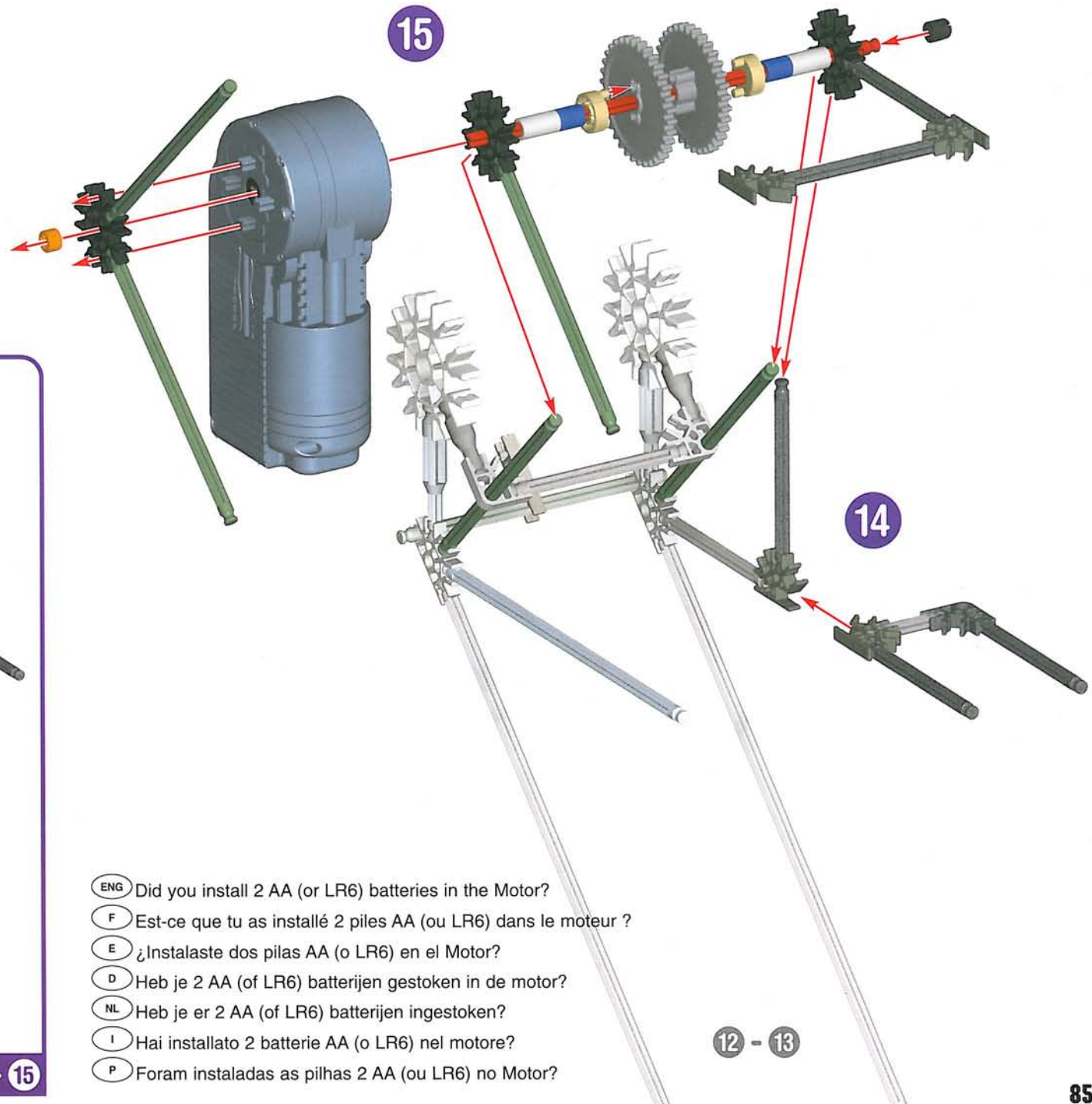

- (ENG) Did you install 2 AA (or LR6) batteries in the Motor?
- (F) Est-ce que tu as installé 2 piles AA (ou LR6) dans le moteur ?
- (E) ¿Instalaste dos pilas AA (o LR6) en el Motor?
- (D) Heb je 2 AA (of LR6) batterijen gestoken in de motor?
- (NL) Heb je er 2 AA (of LR6) batterijen ingestoken?
- (I) Hai installato 2 batterie AA (o LR6) nel motore?
- (P) Foram instaladas as pilhas 2 AA (ou LR6) no Motor?

12 - 13

16

12 - 15

1 - 11

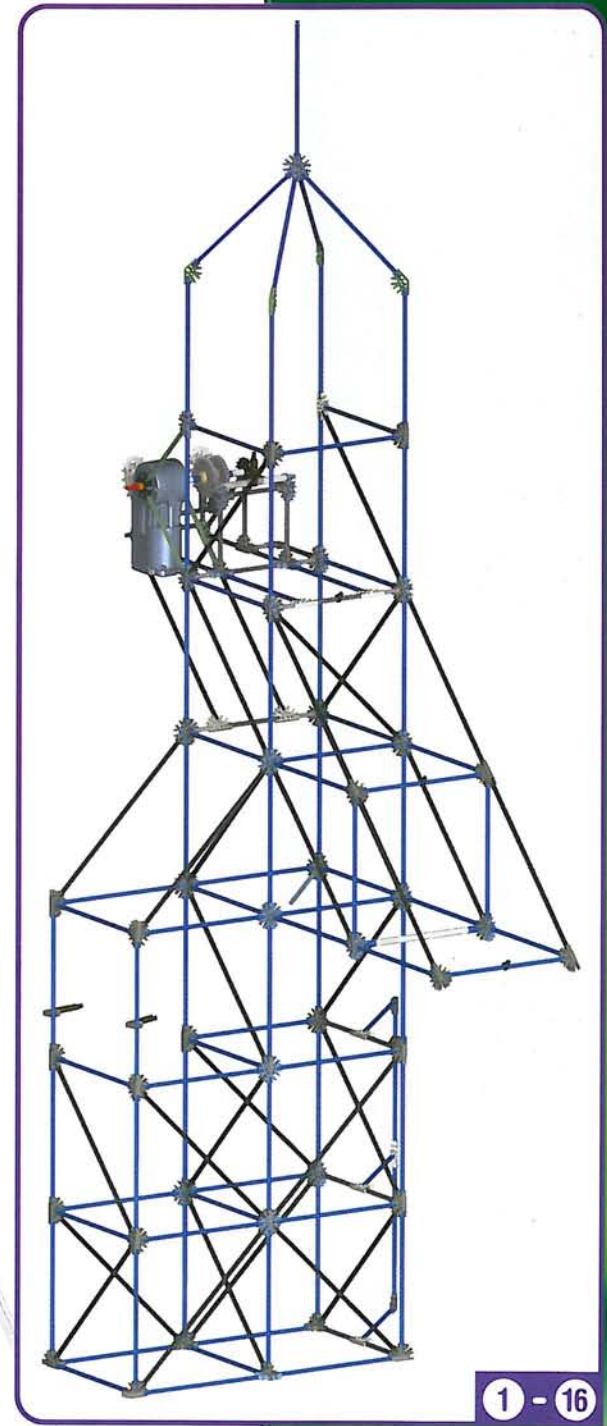
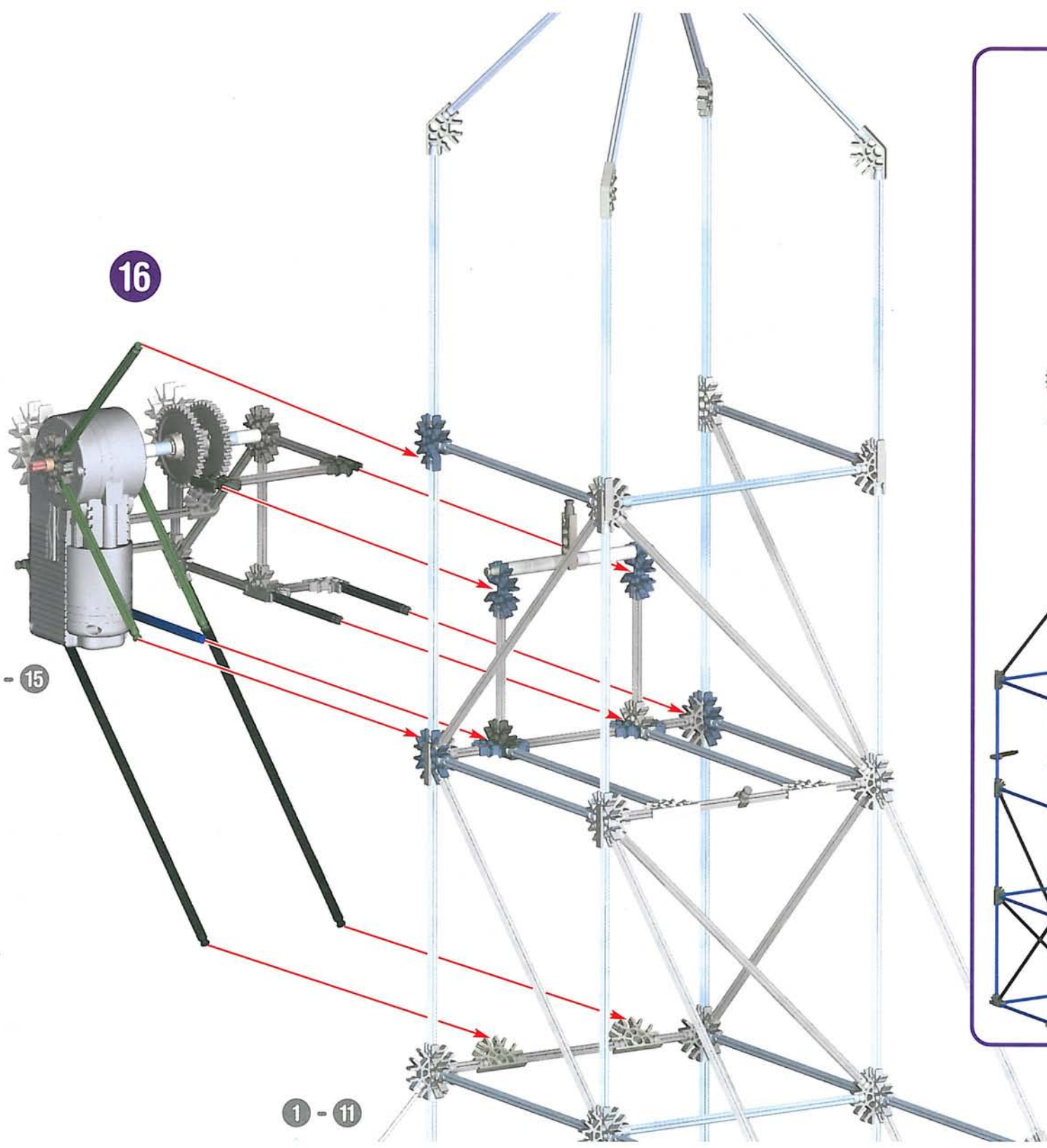

1 - 16

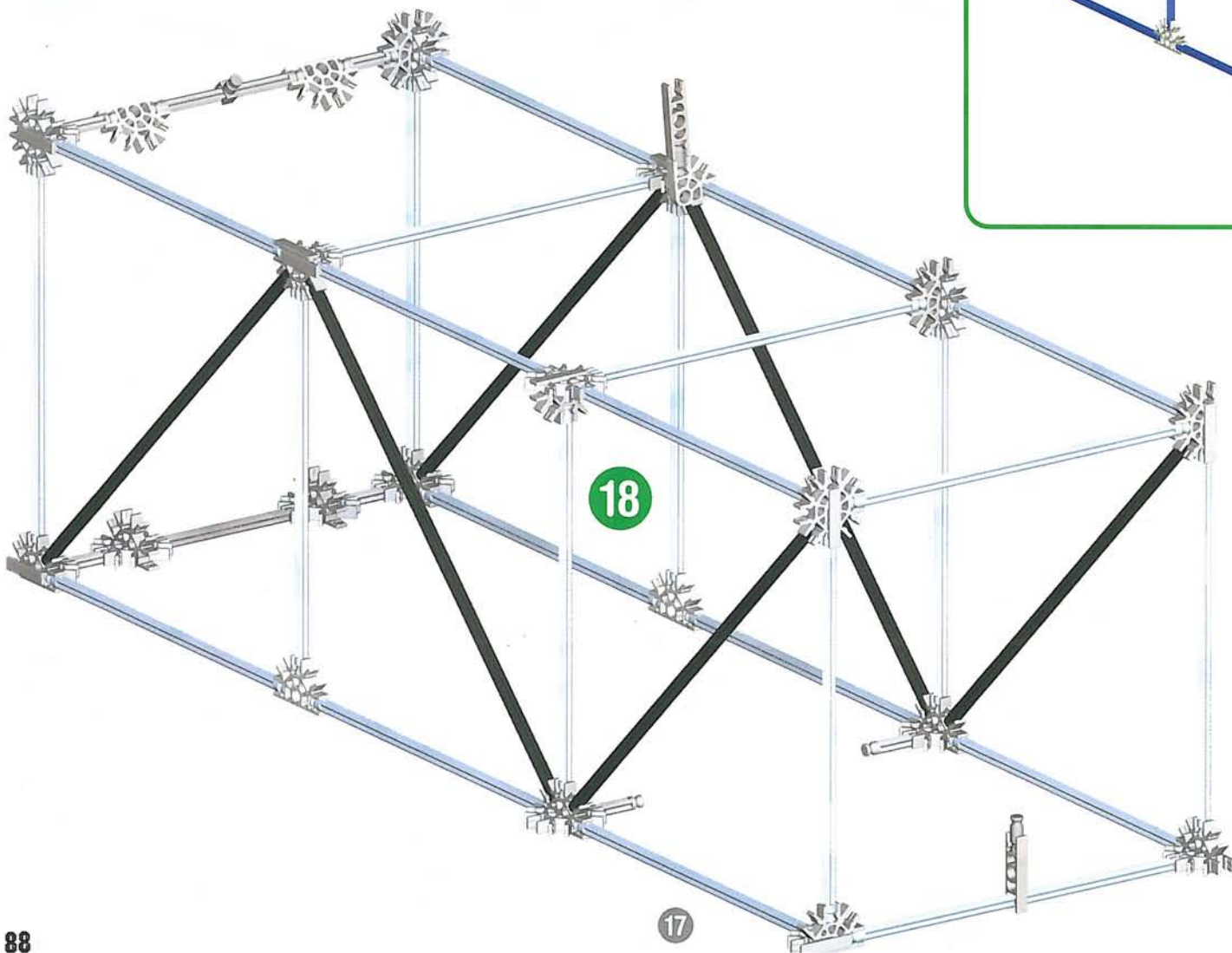
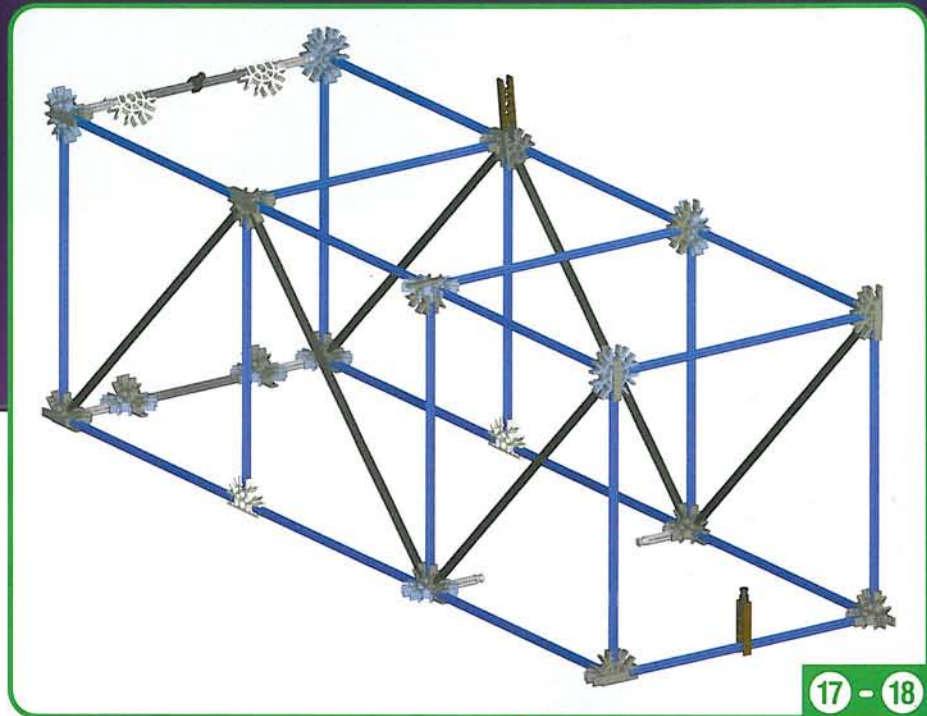

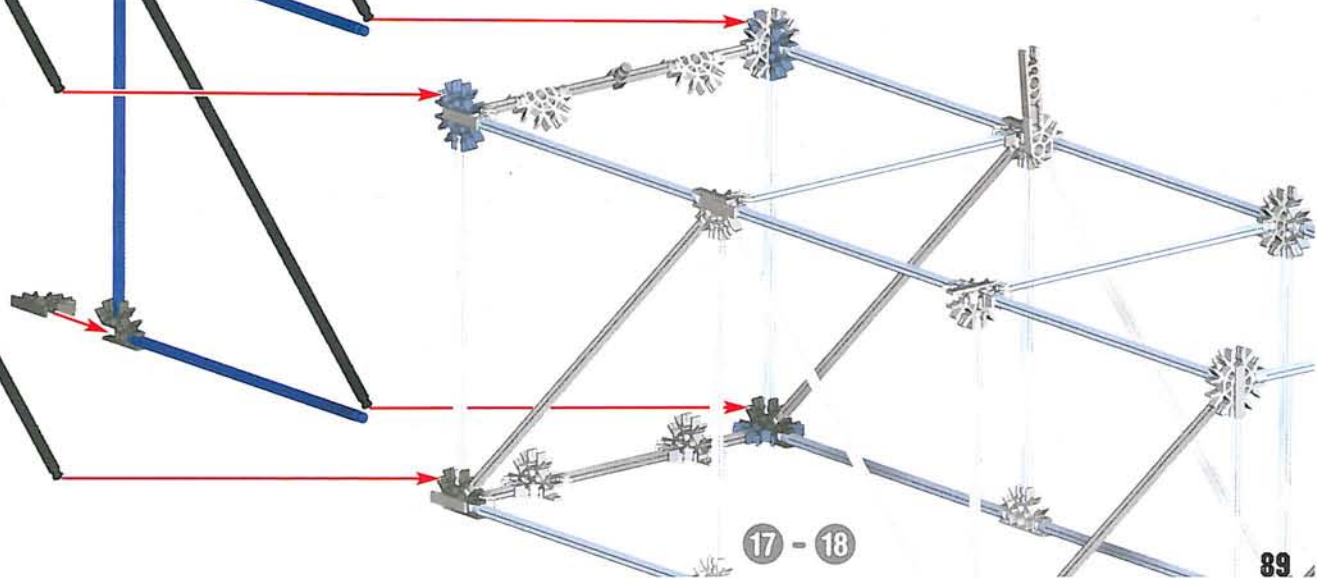
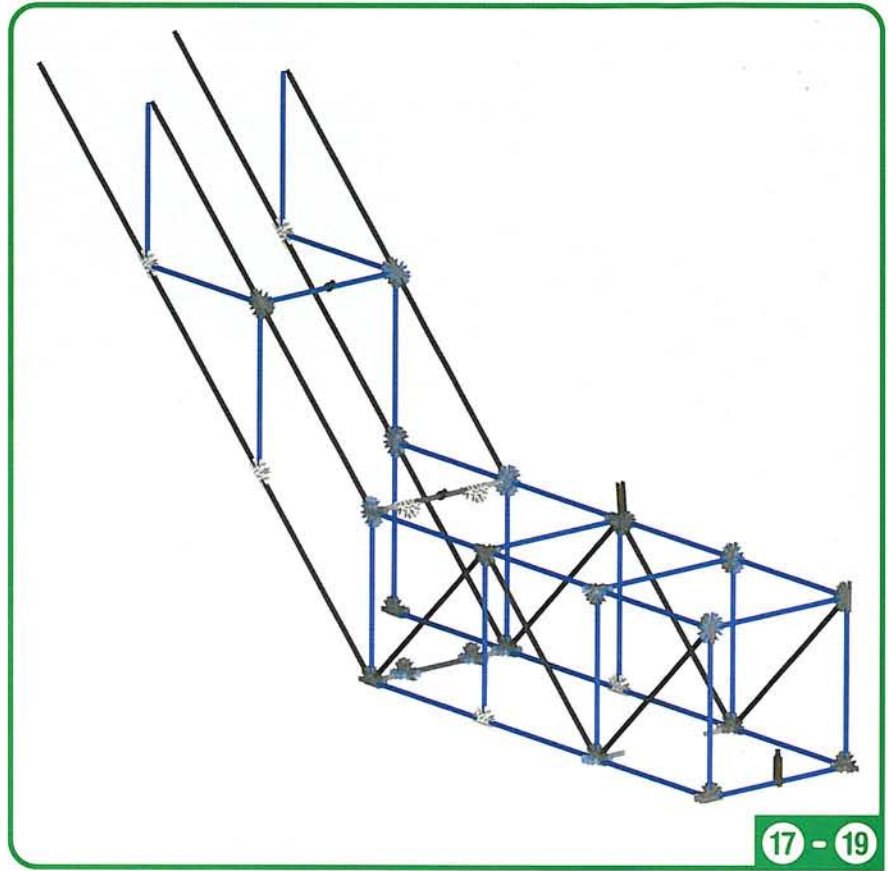
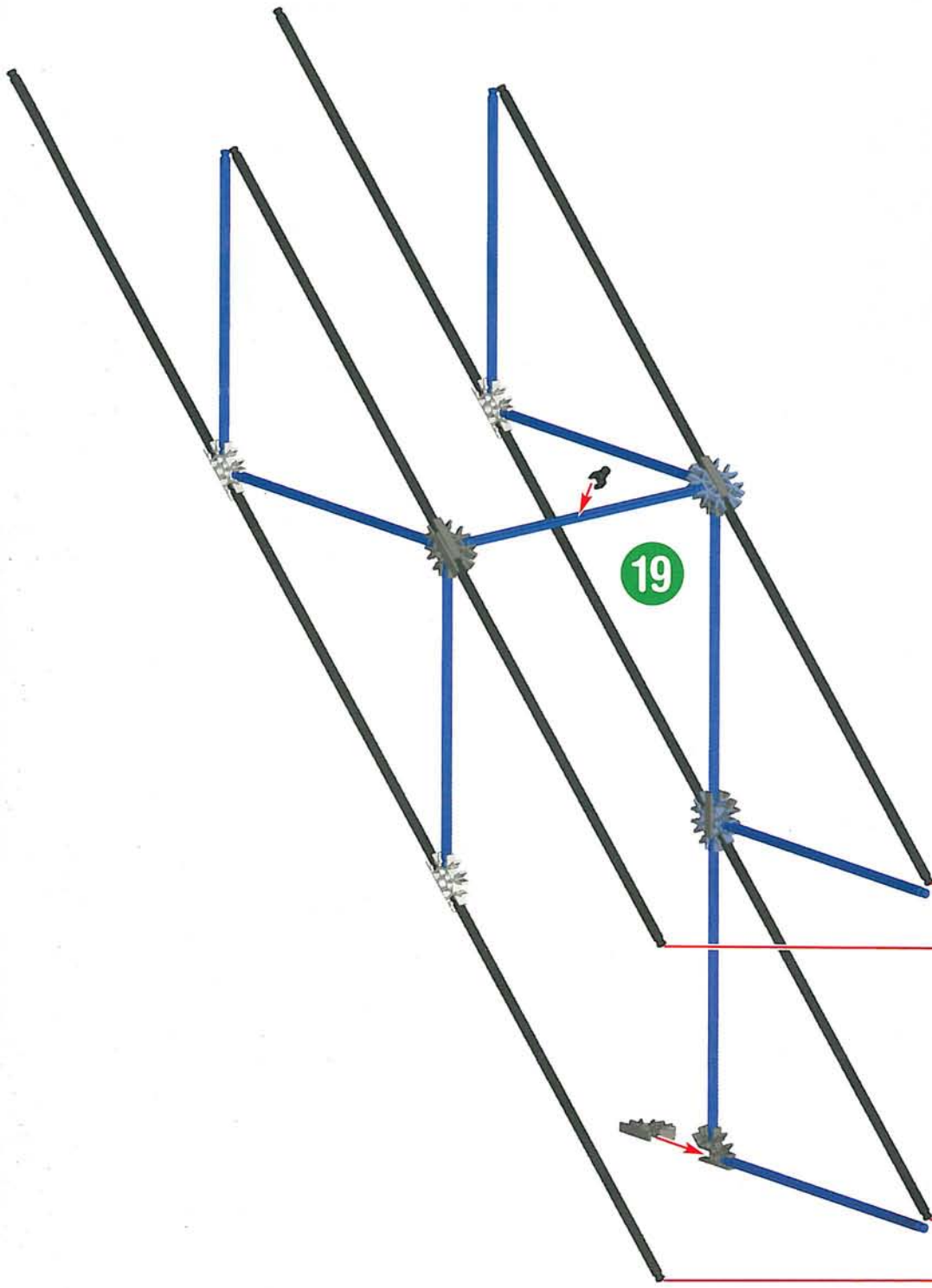

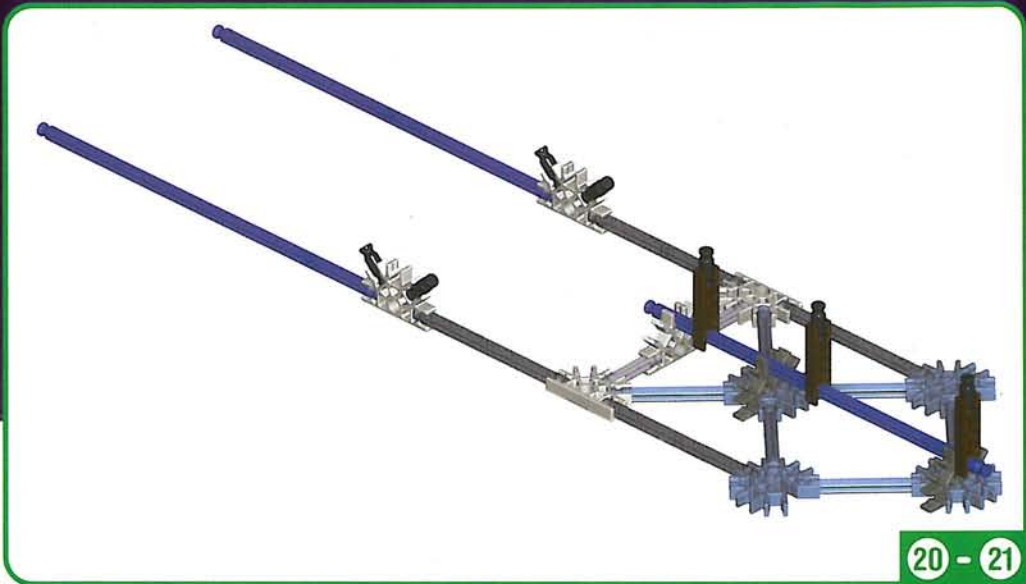

20 - 21

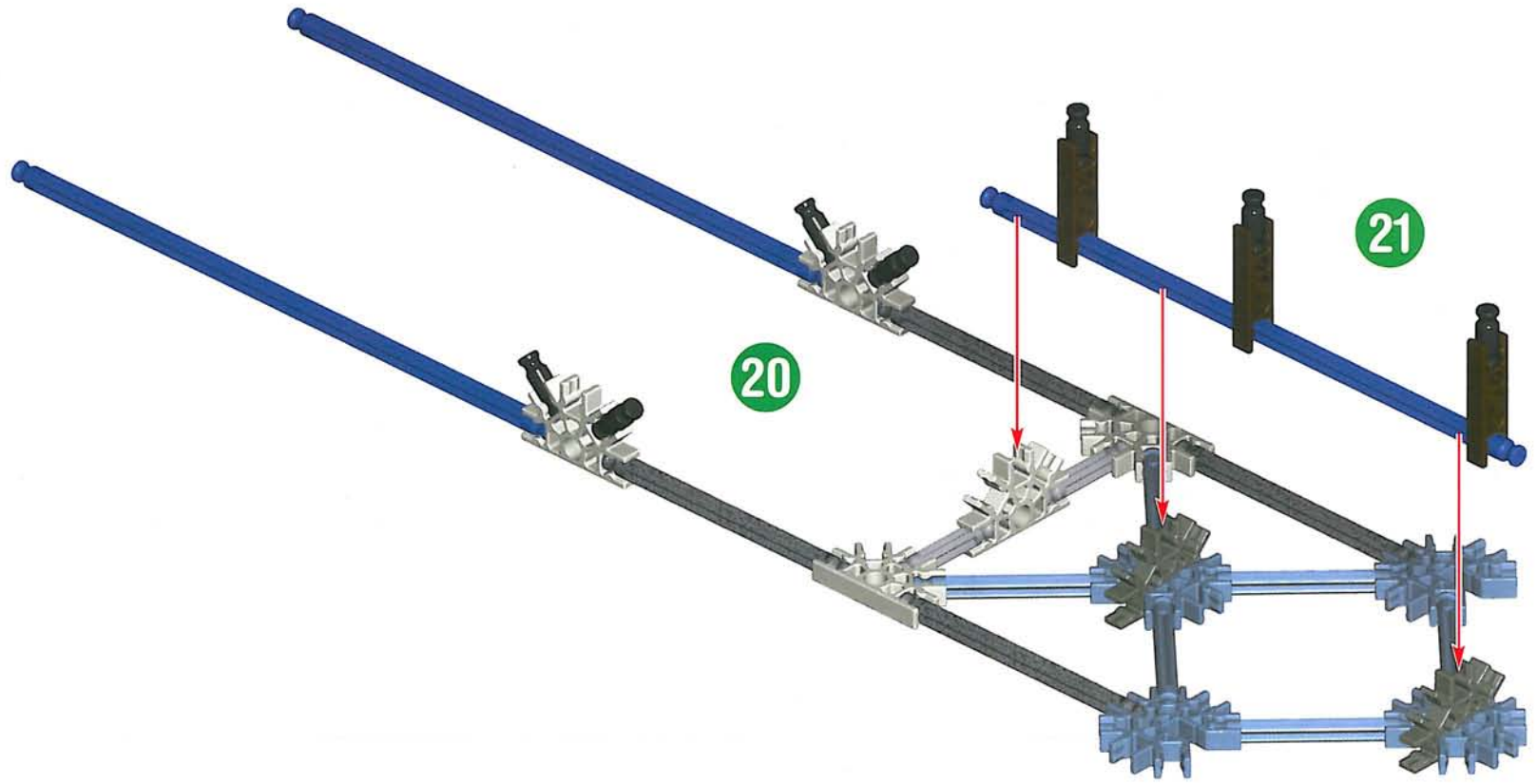

20

21

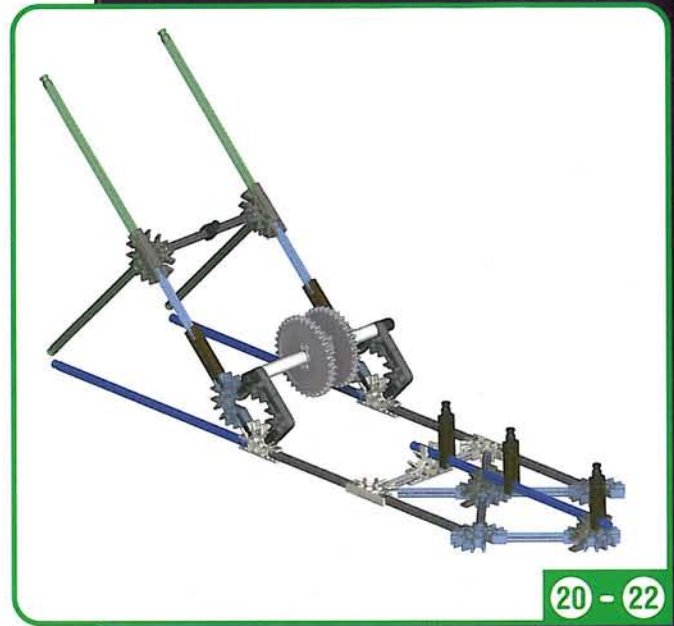
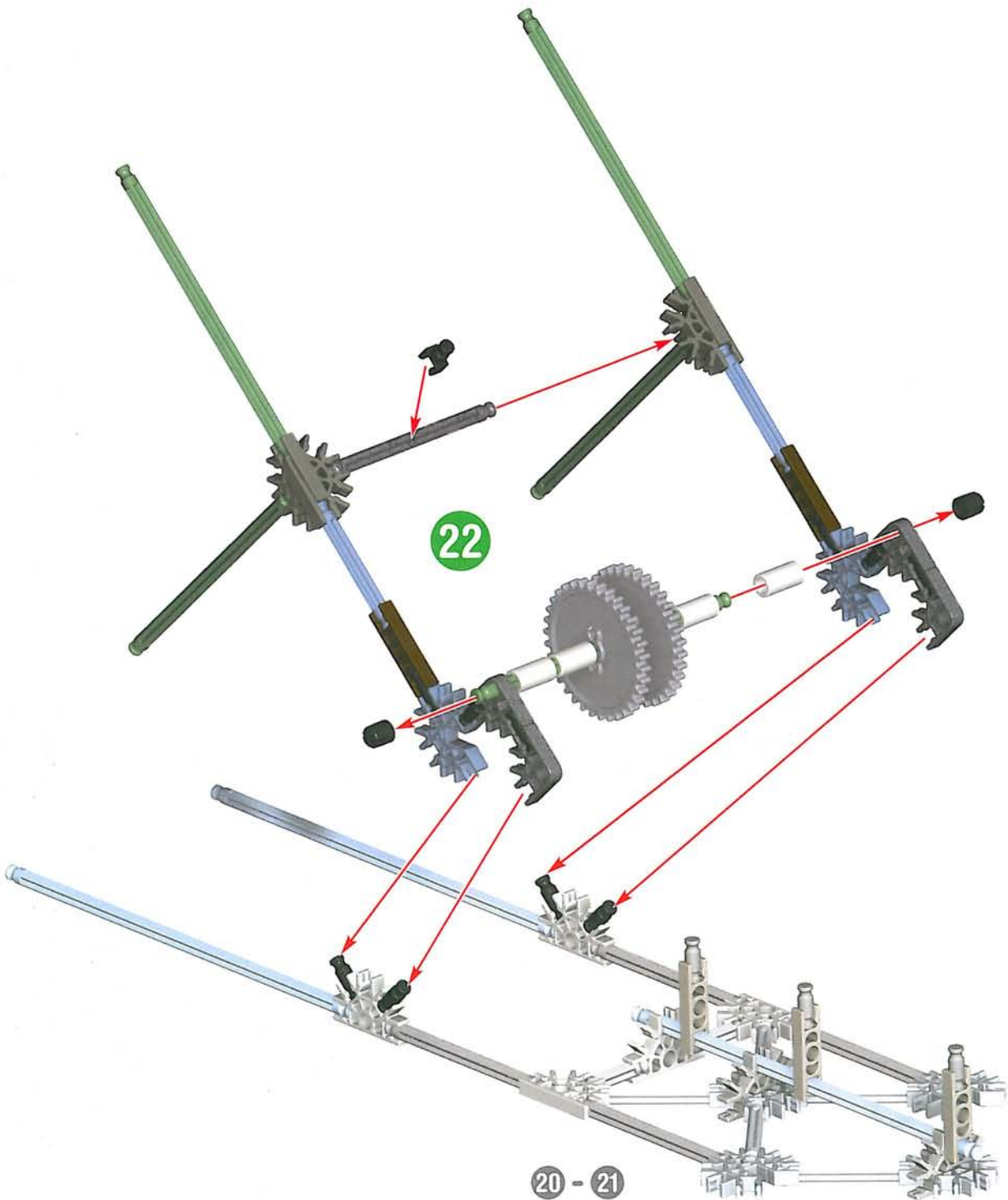

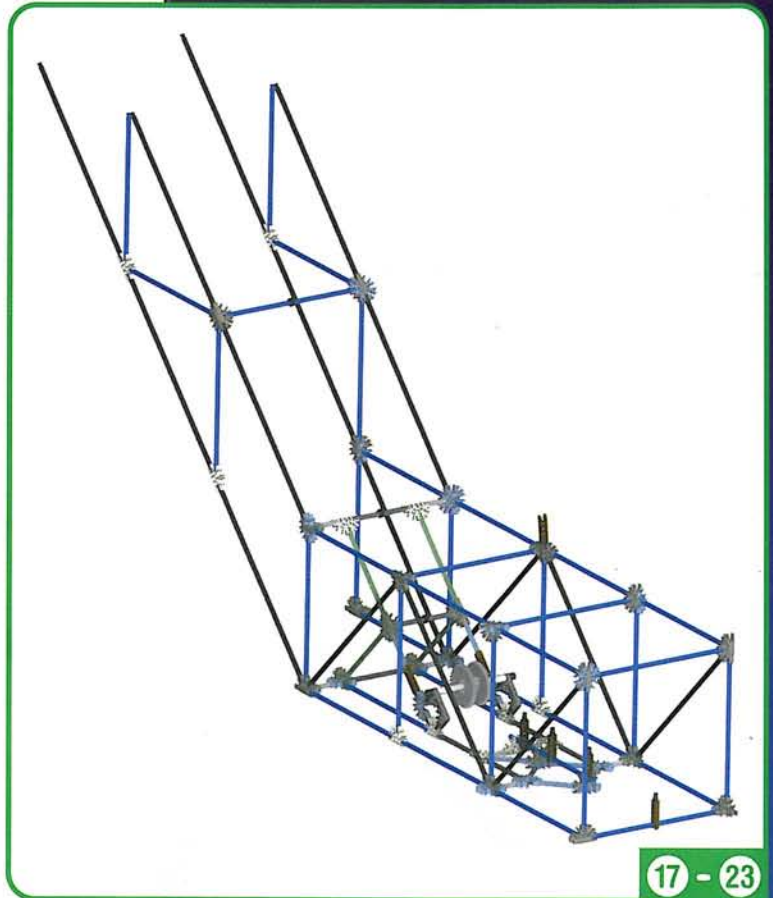
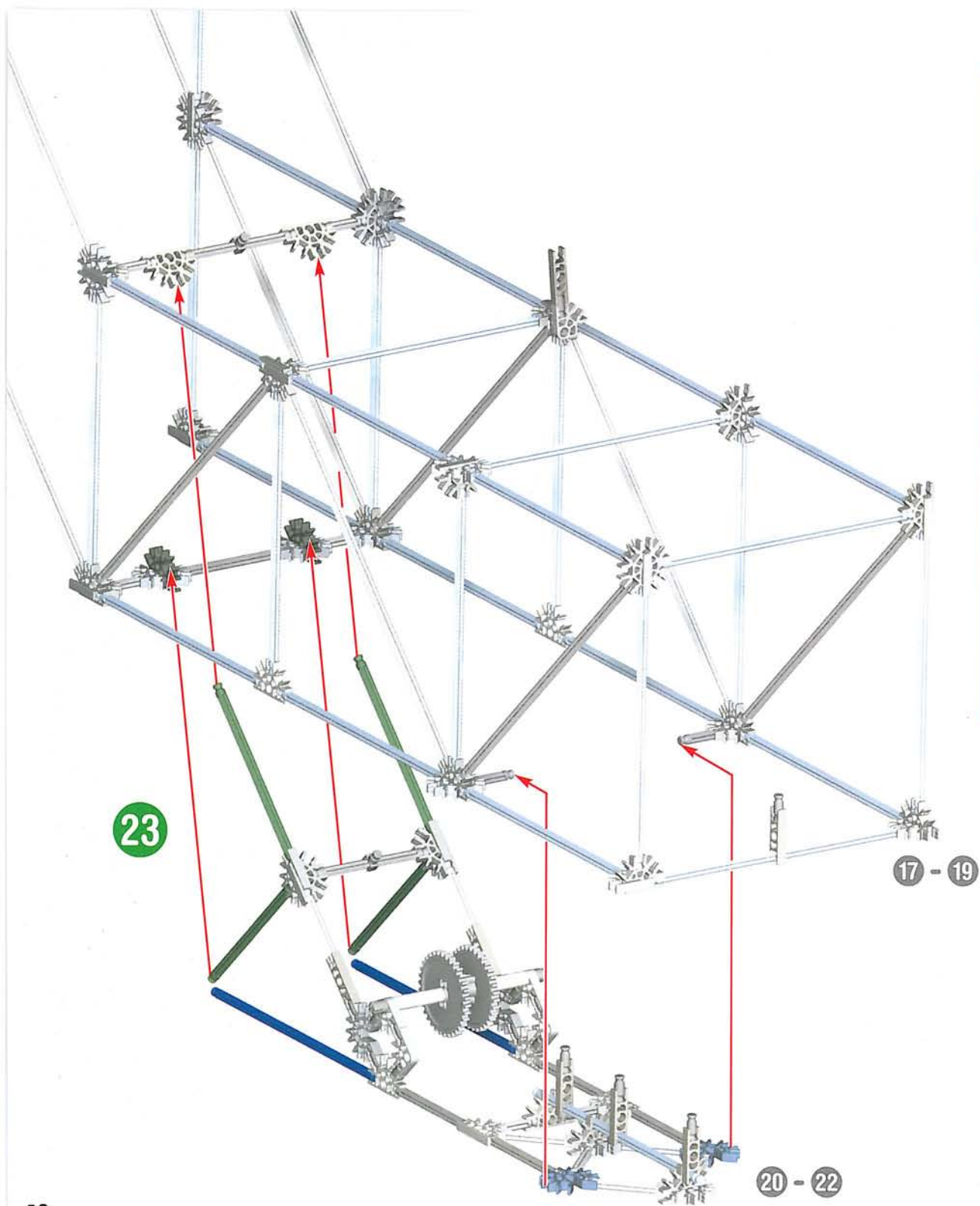

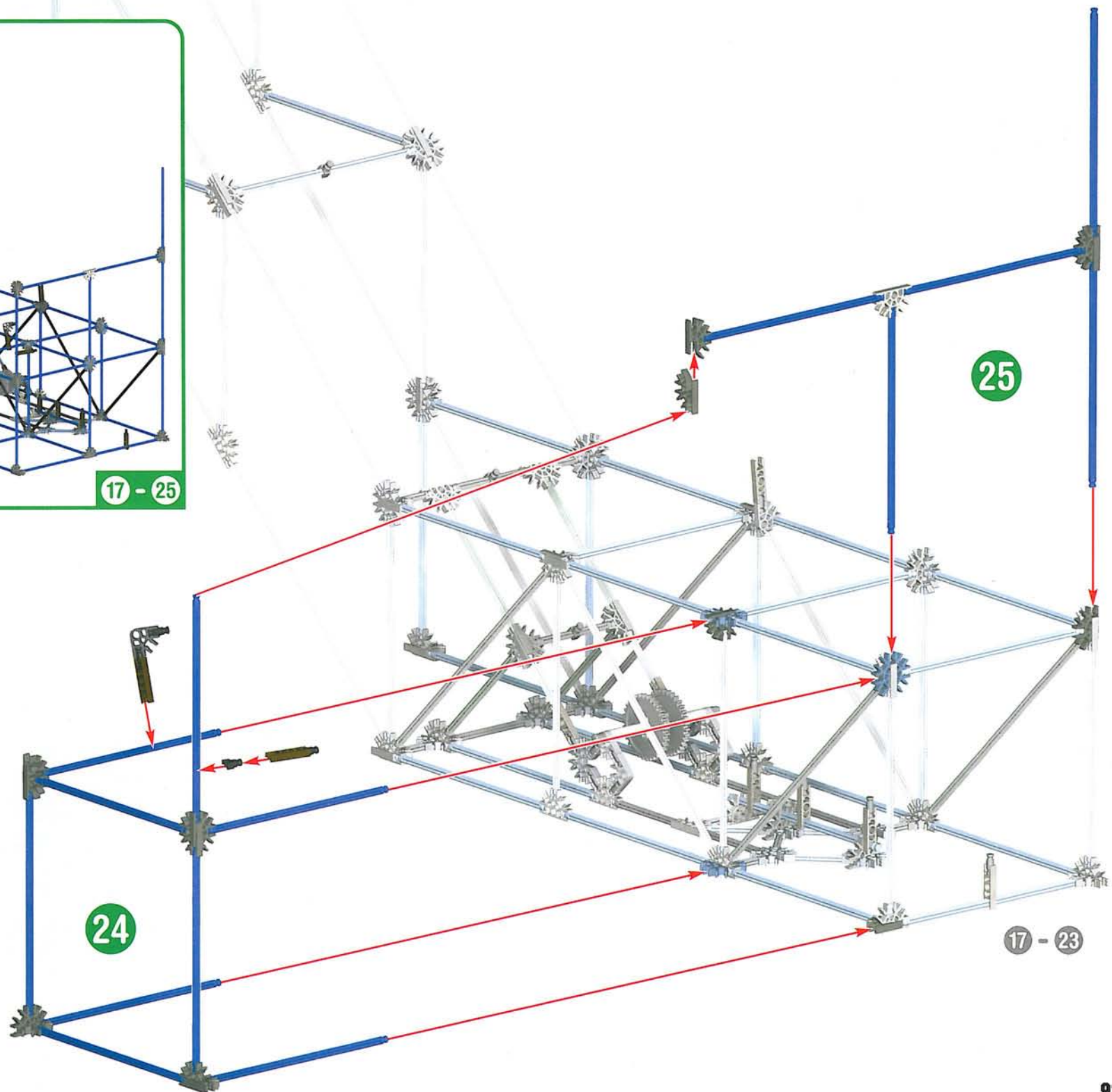
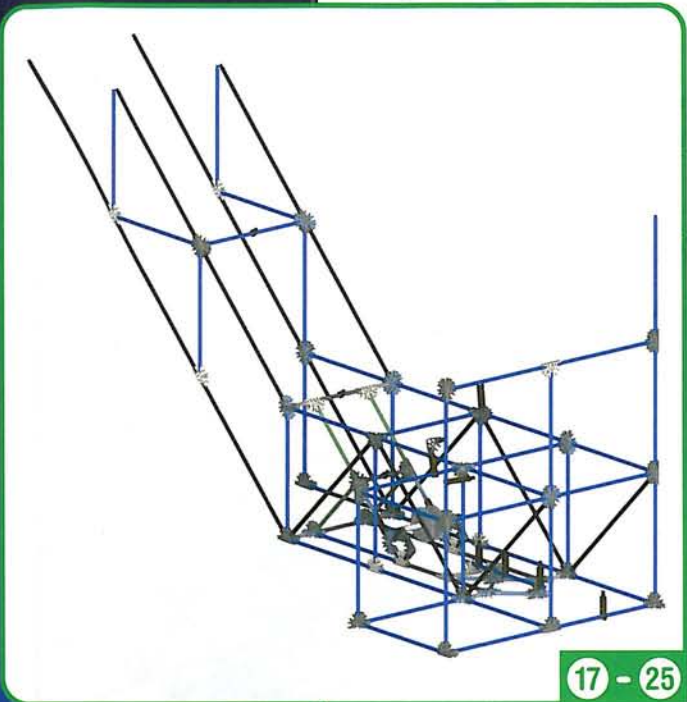

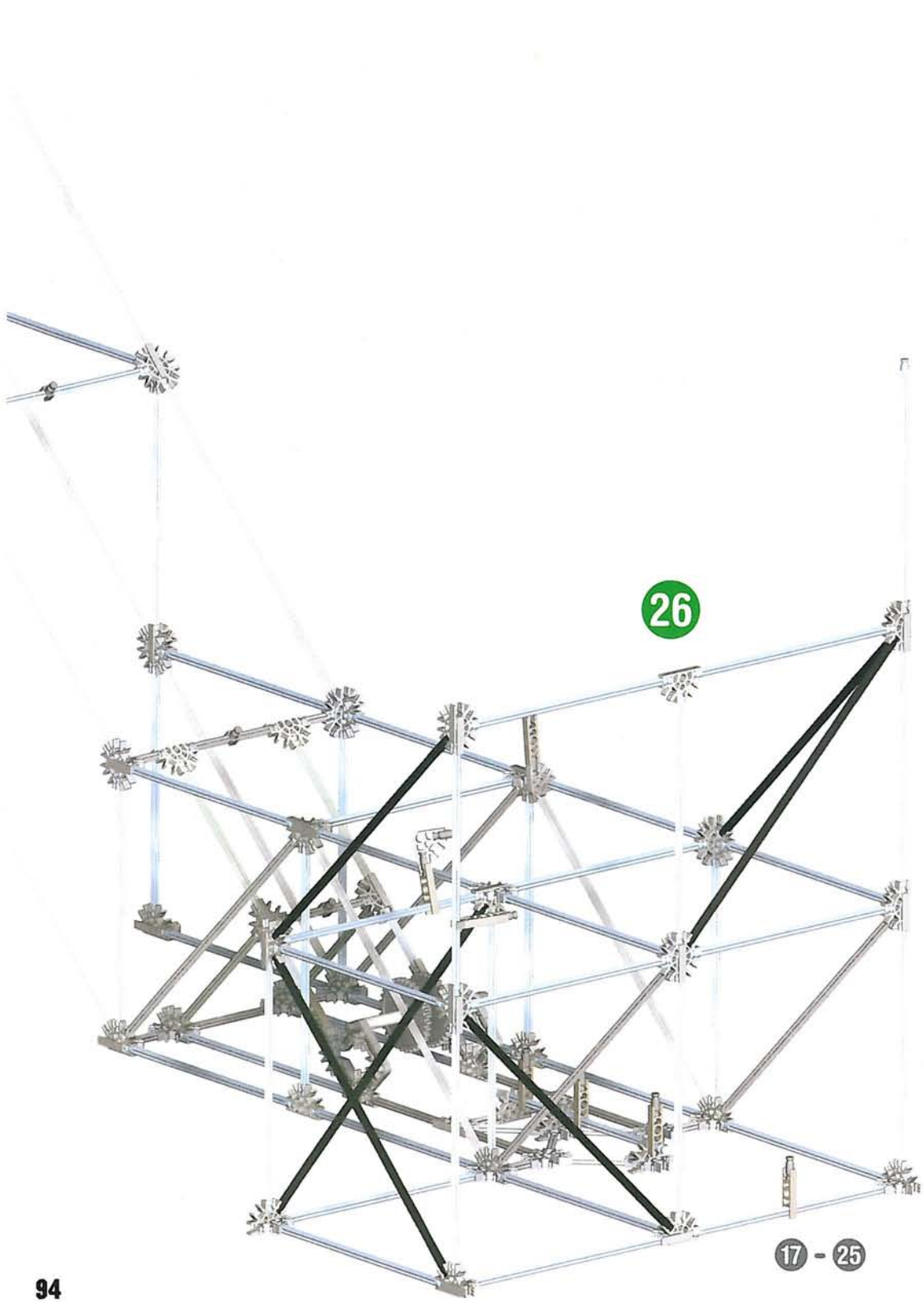

26

17 - 25

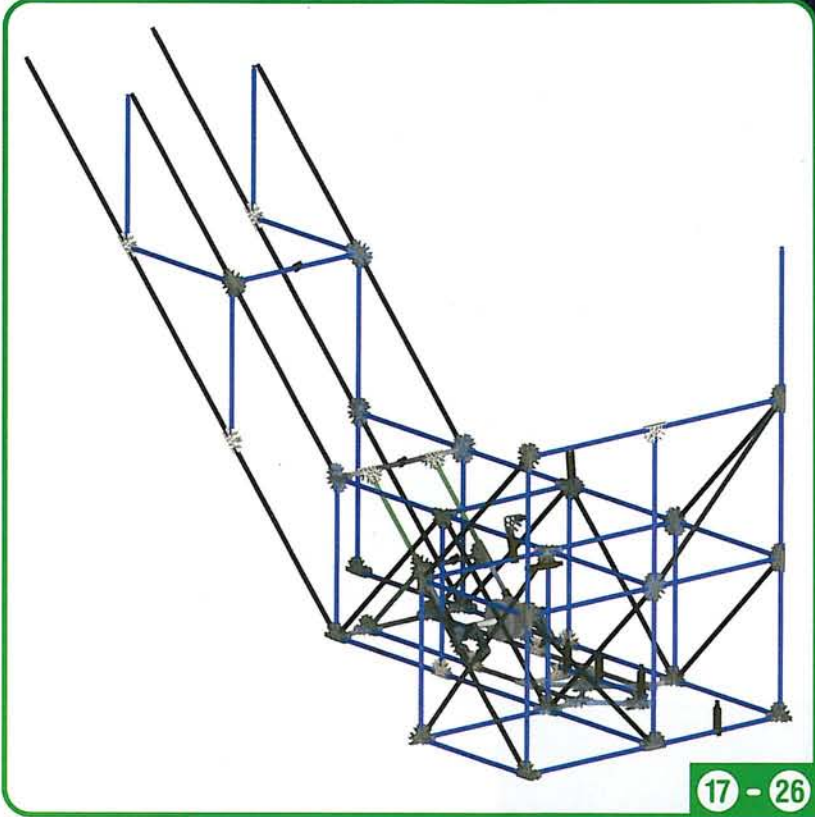

17 - 26

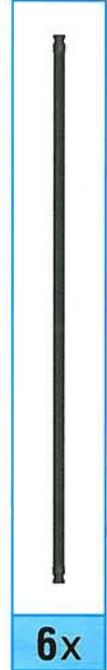

6x

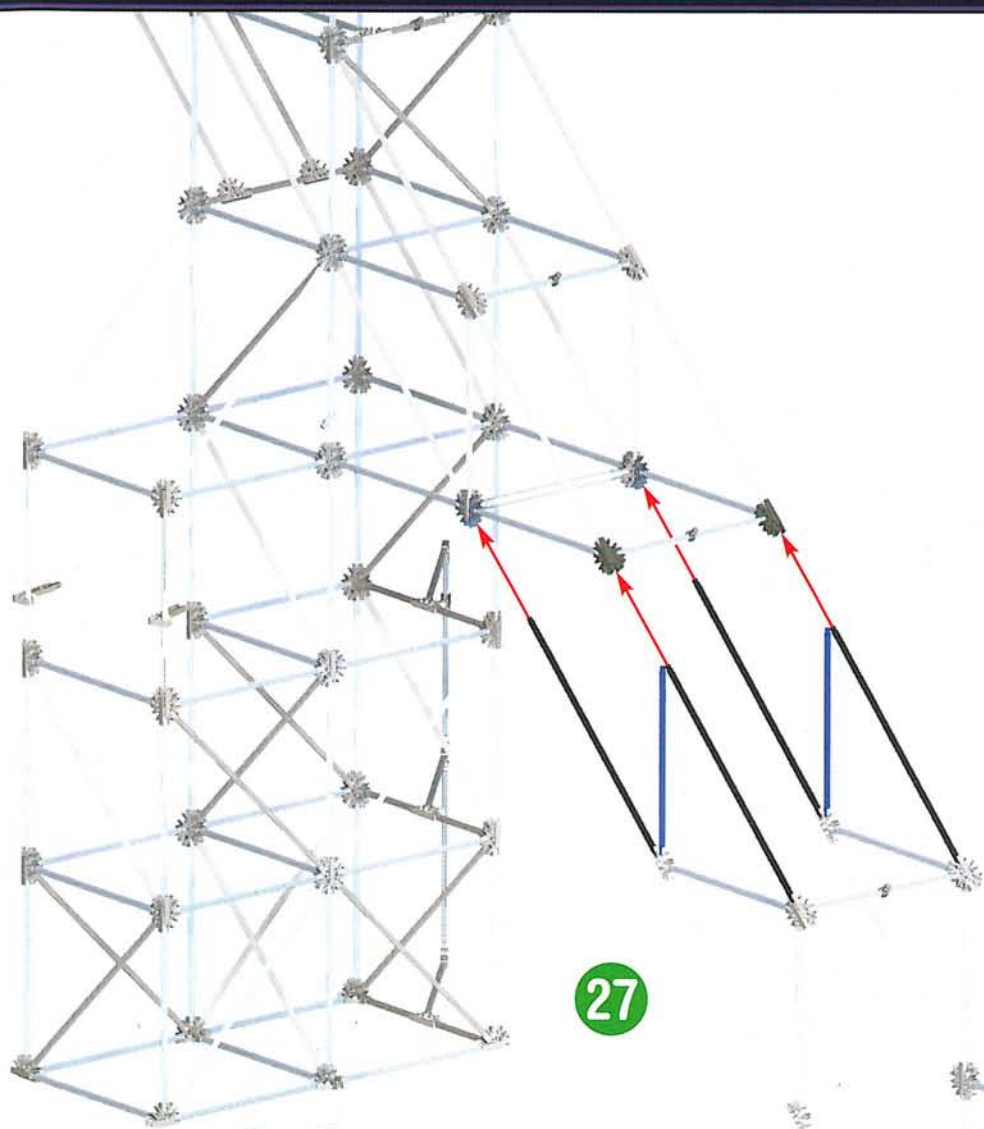

1 - 16

27

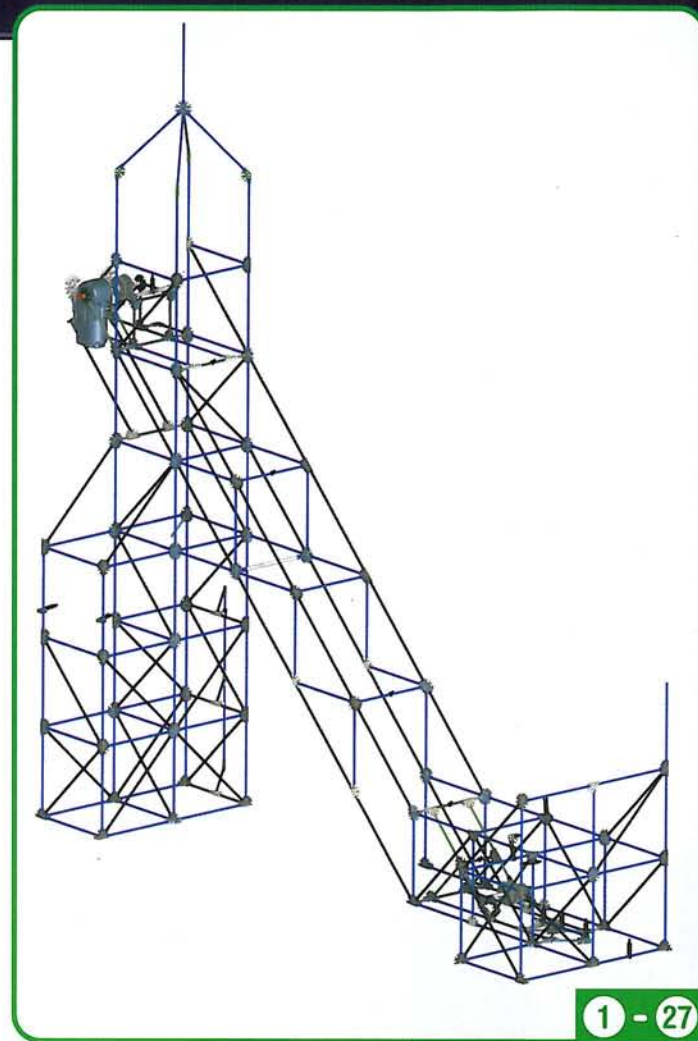

1 - 27

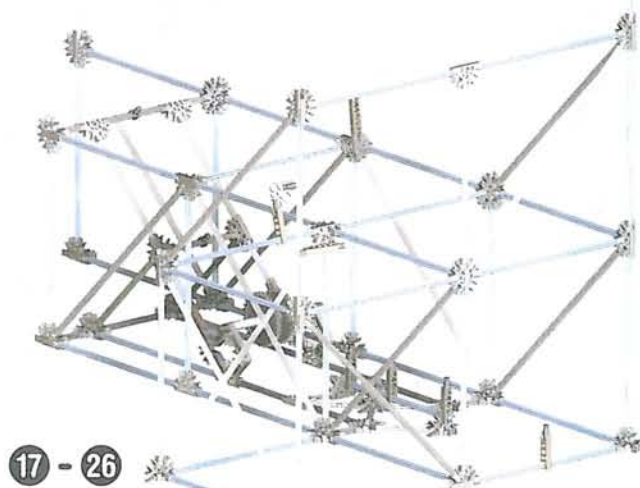

17 - 26

ALTERNATE COASTER:
(INTERMEDIATE BUILD)

TOWER 3

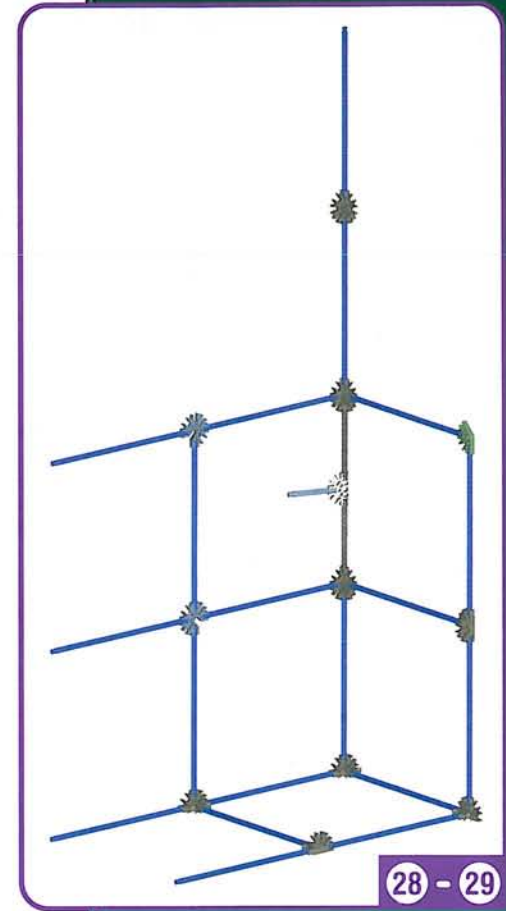
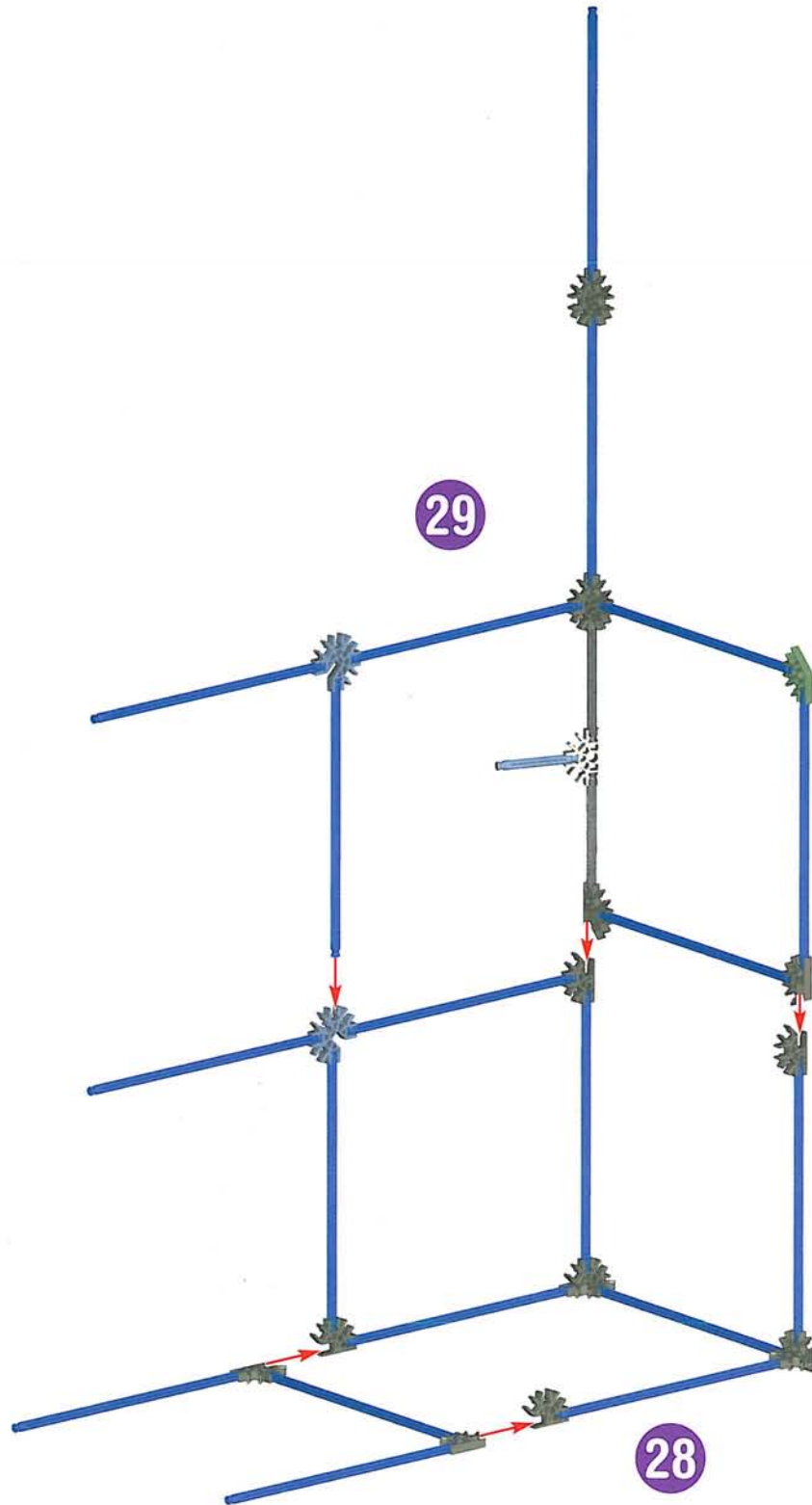
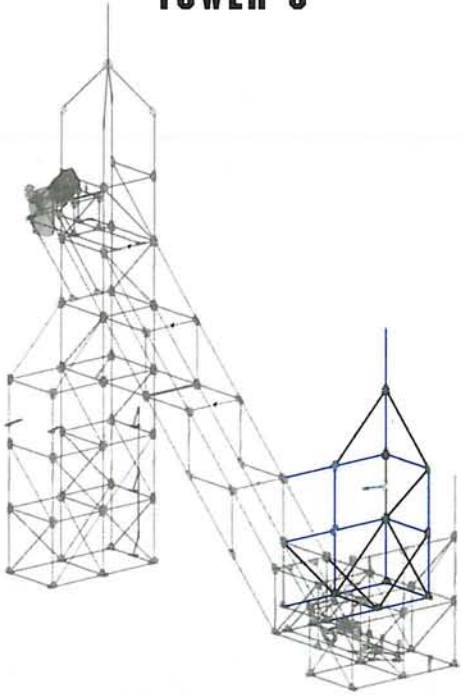



5x

30

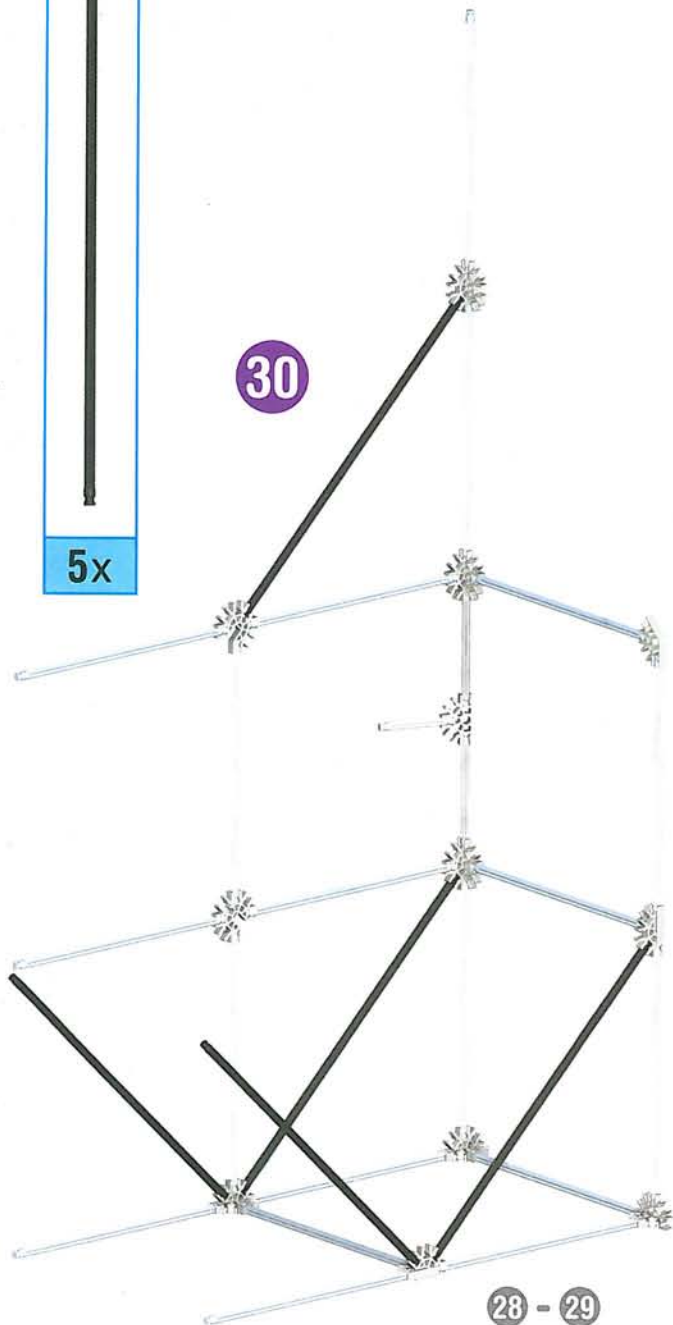

28 - 29

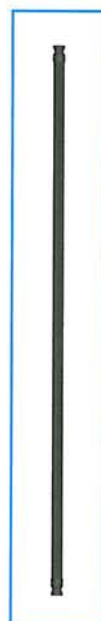

3x

31

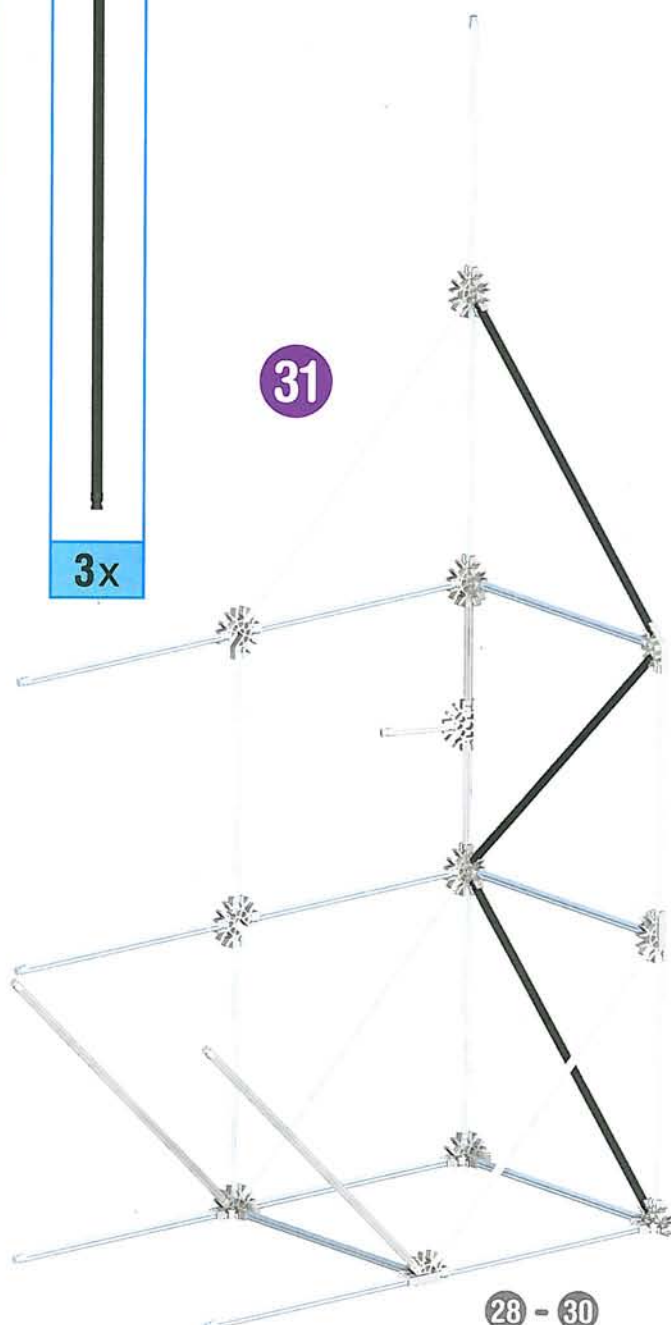

28 - 30

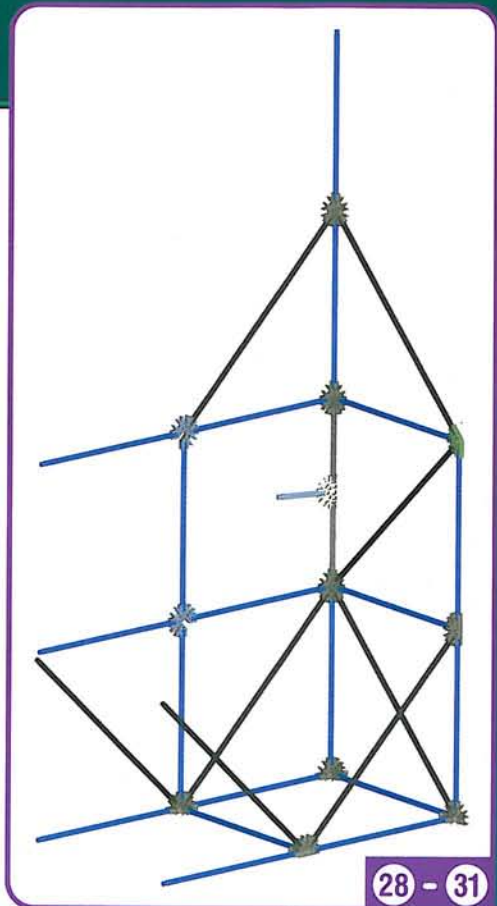

28 - 31

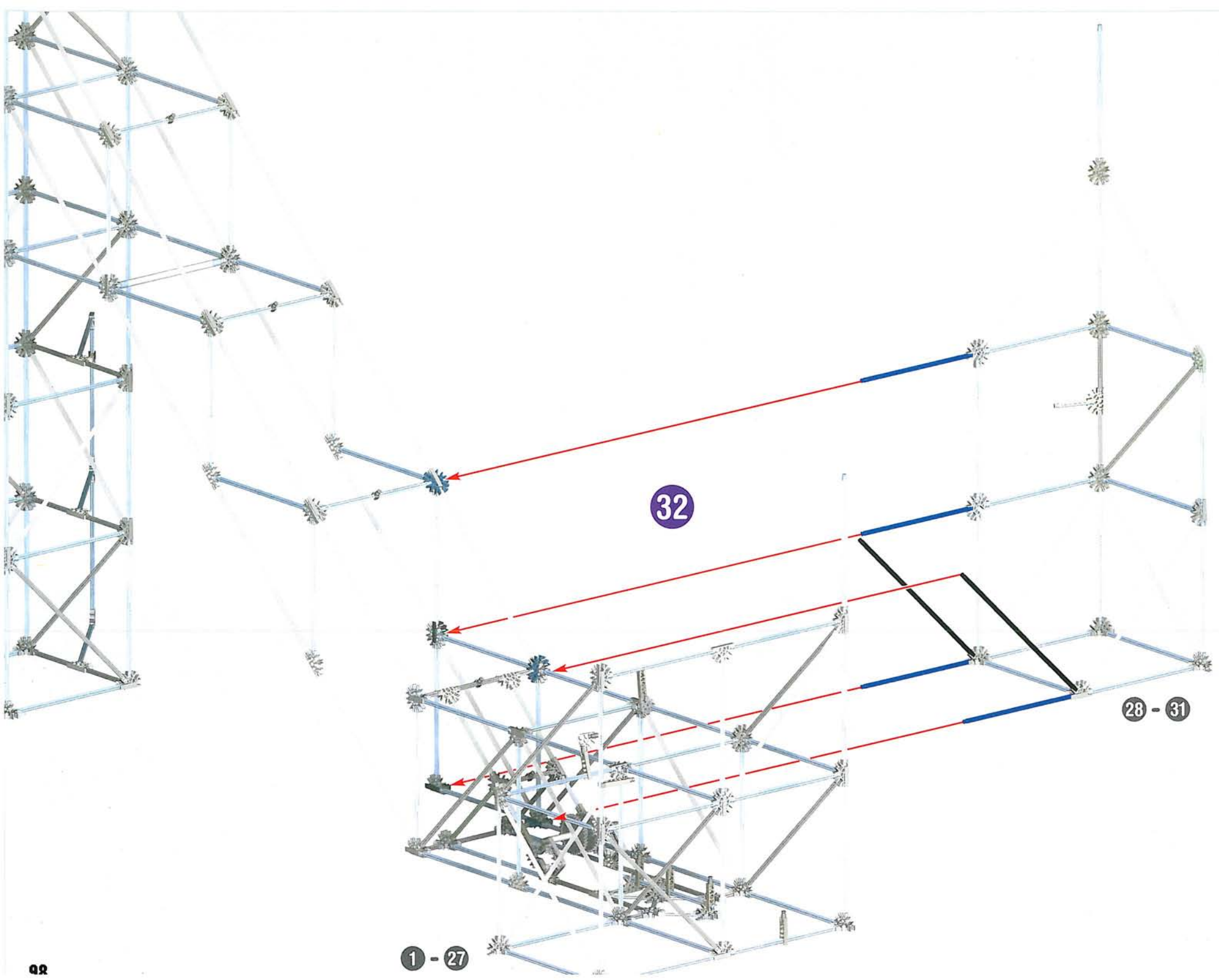

33

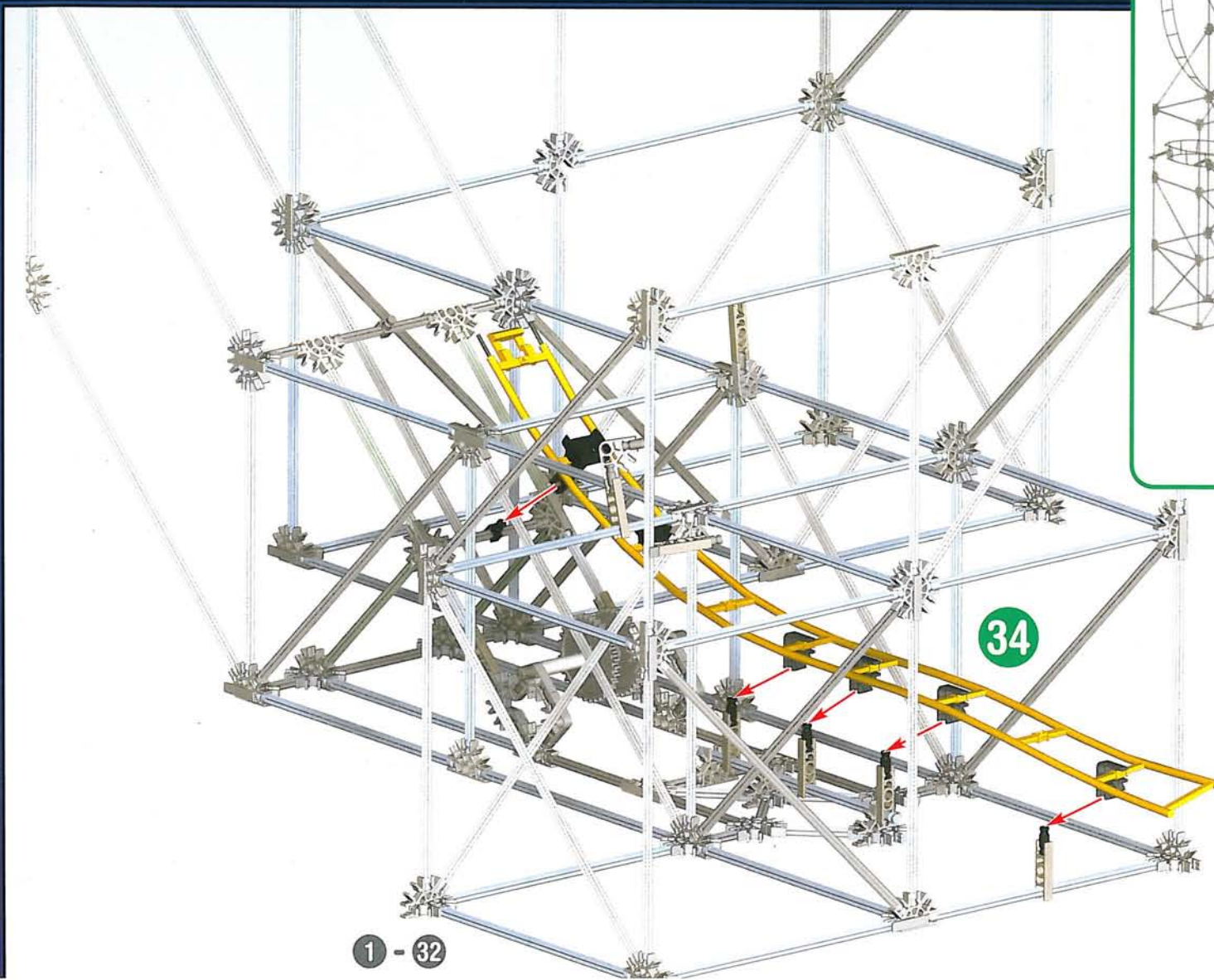
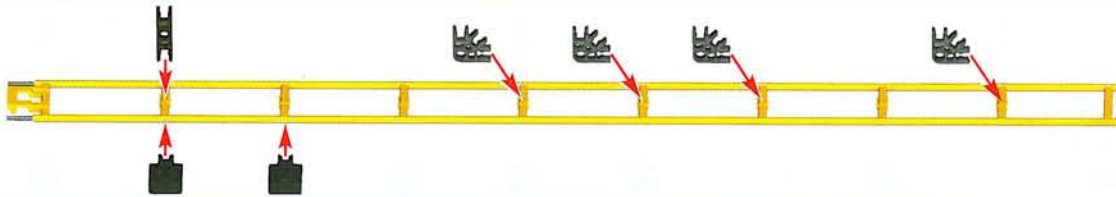

34

1 - 32

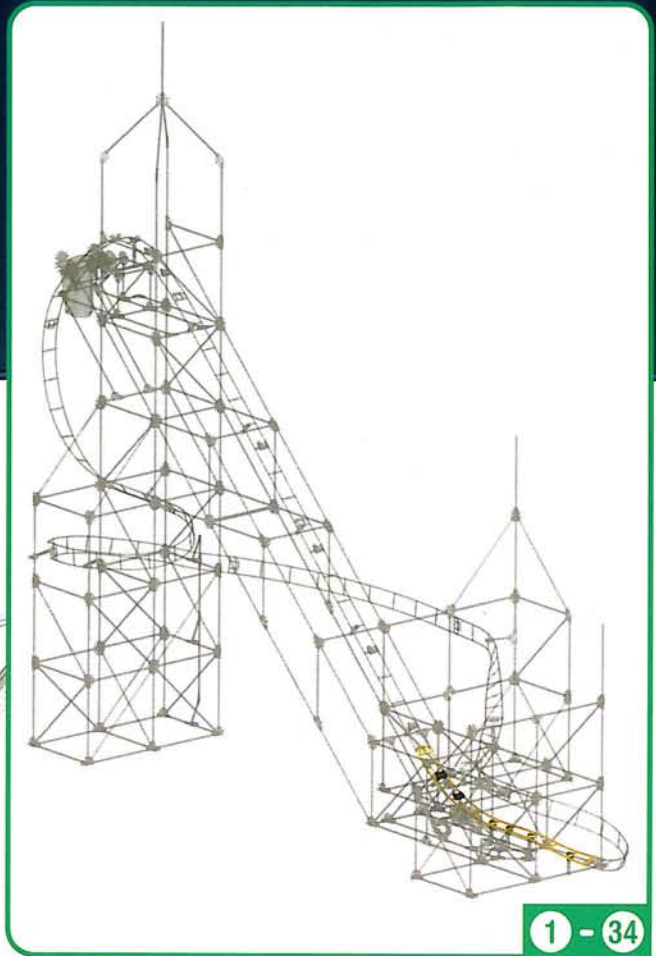

1 - 34

Track Tips:

1. There is a top and bottom side to the Track. Always connect the Track top side to top side throughout the build.
2. Go to page 42 for more helpful Track tips.

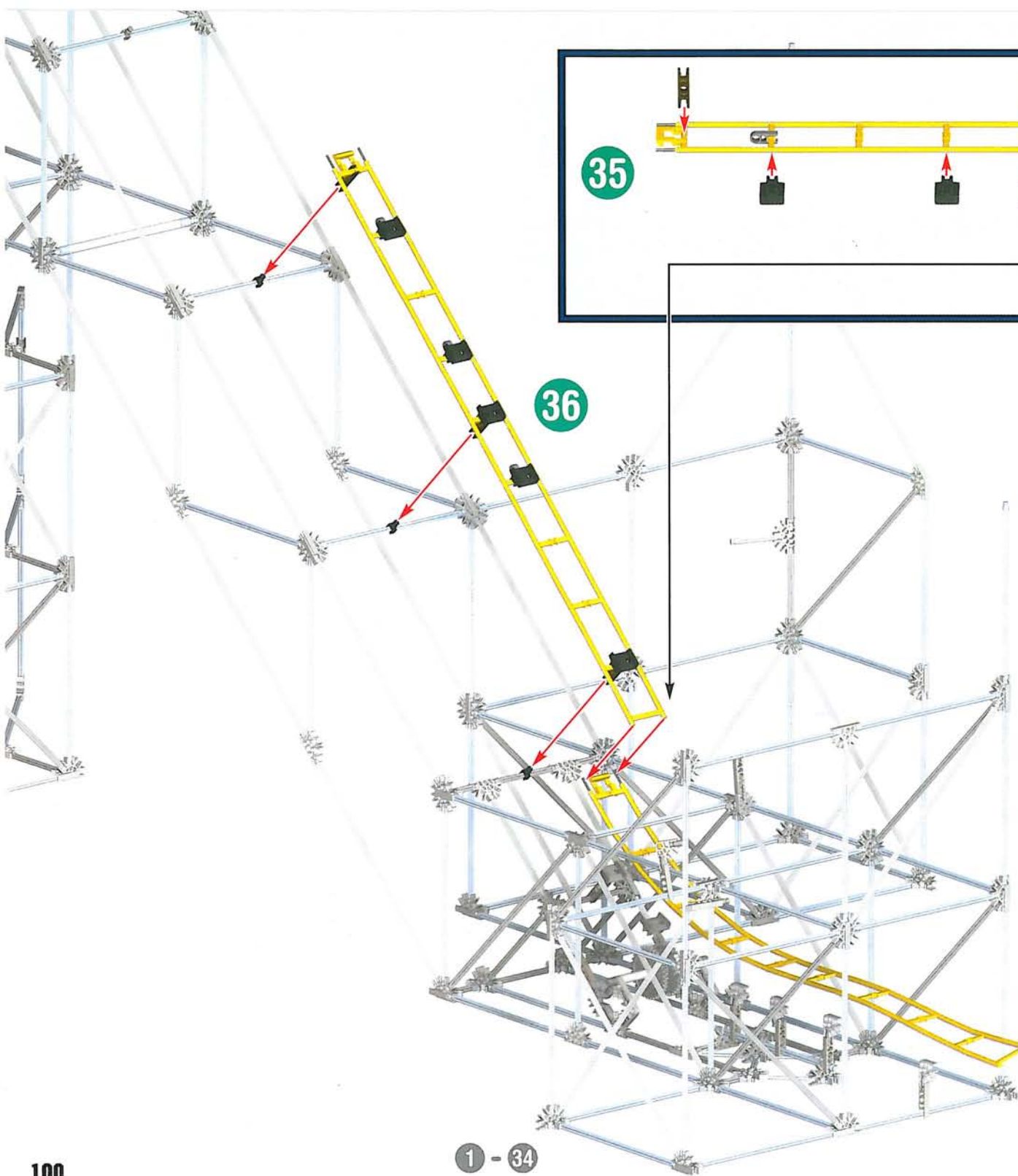

35

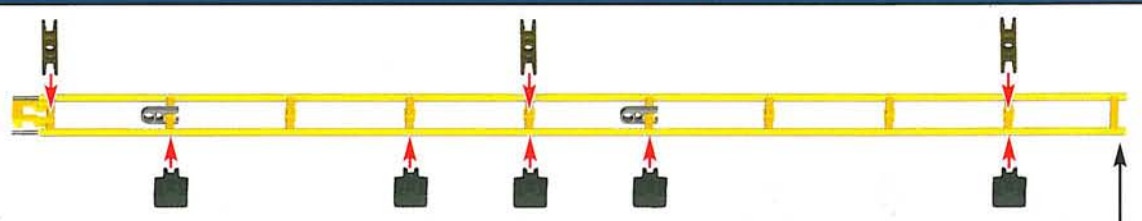

Always join this end of the Track to the previous Track piece first, then connect the rest of the Track to the tower.

36

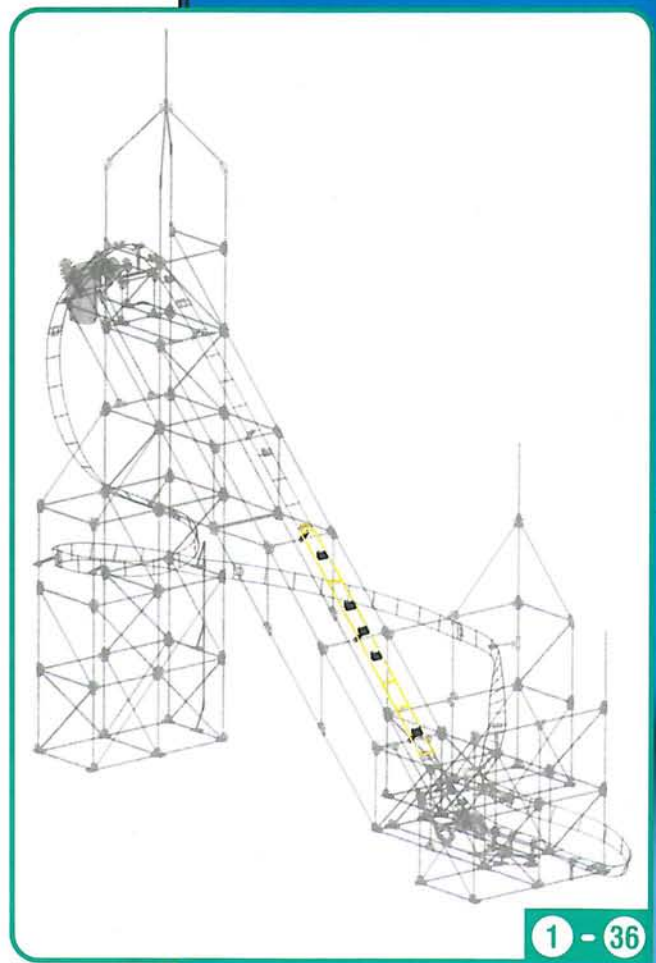

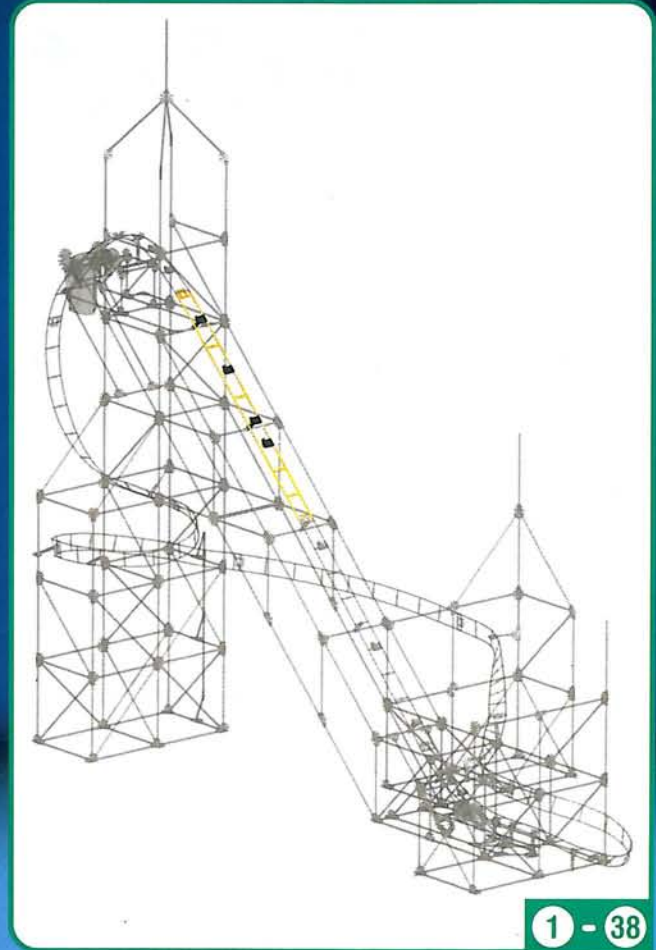
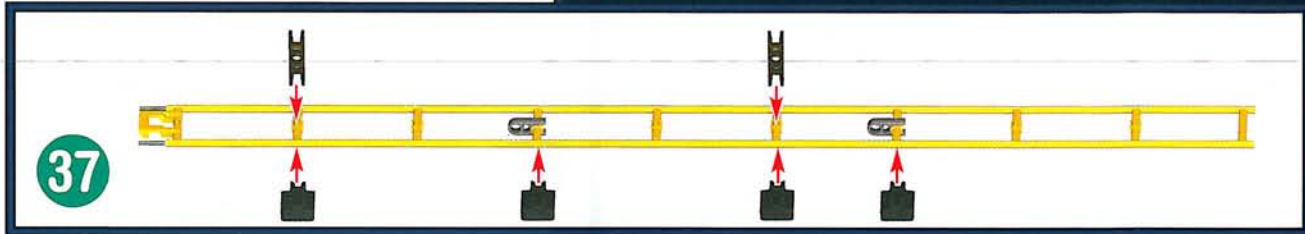
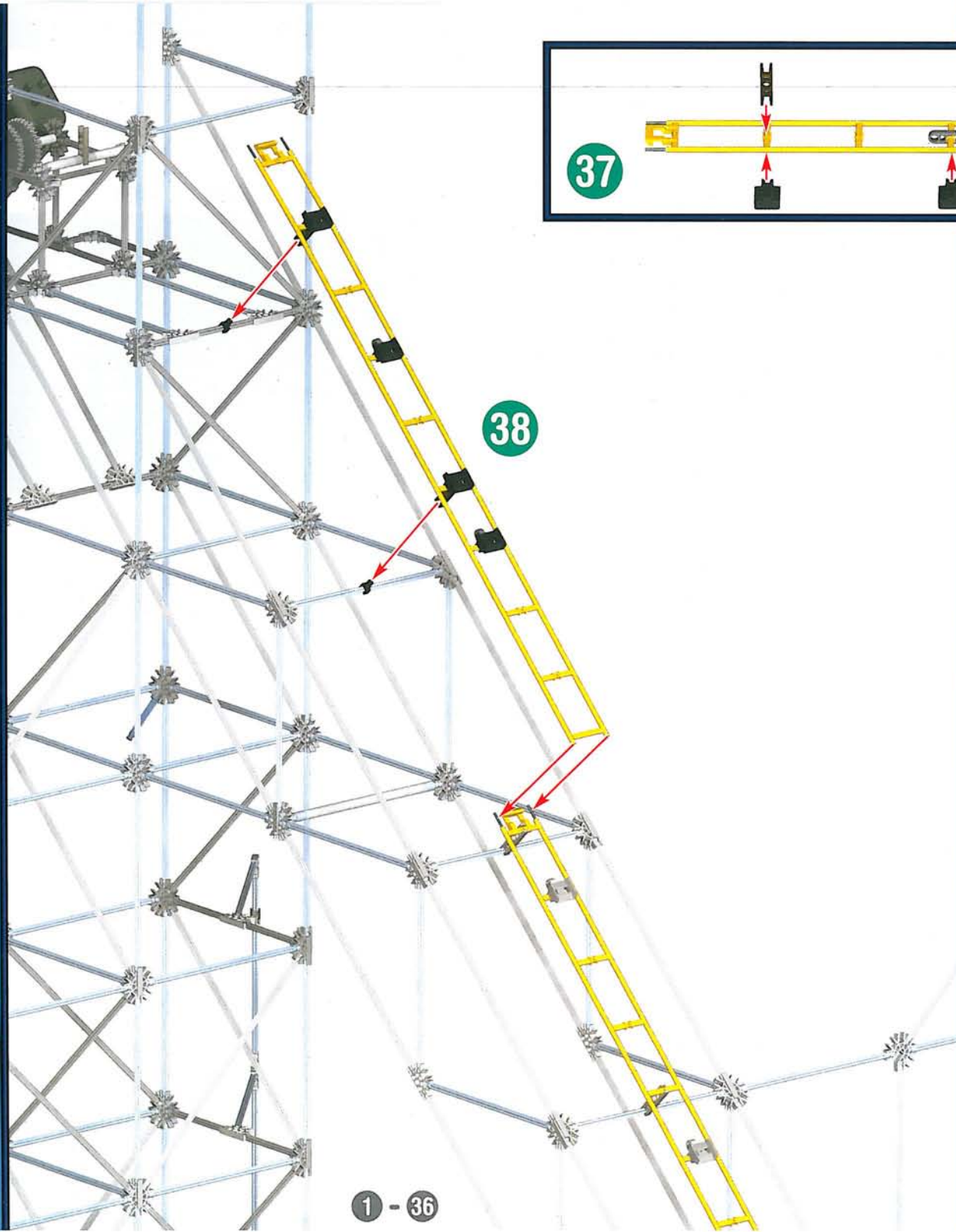

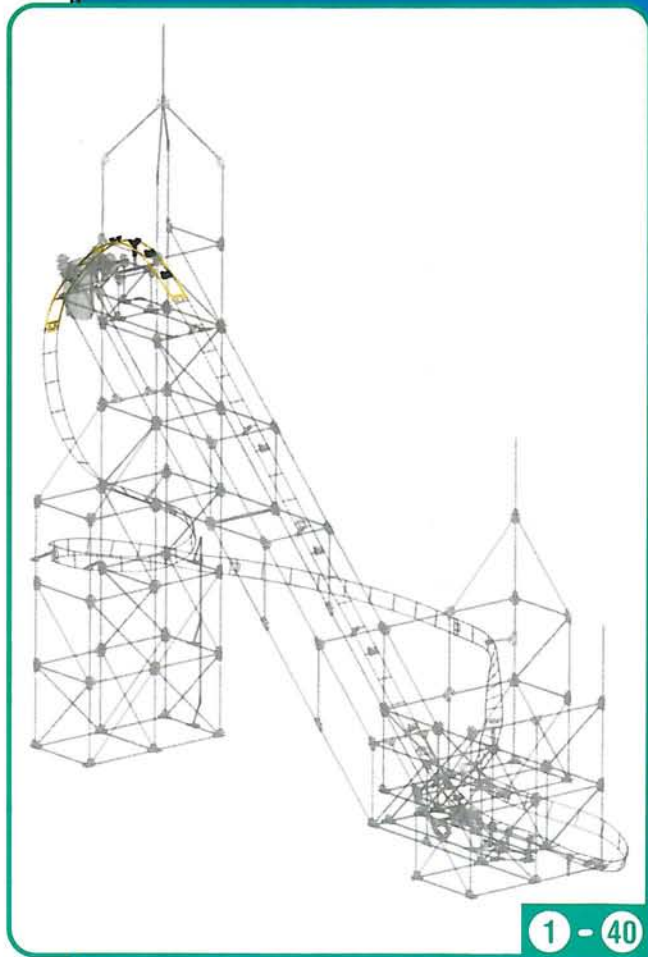
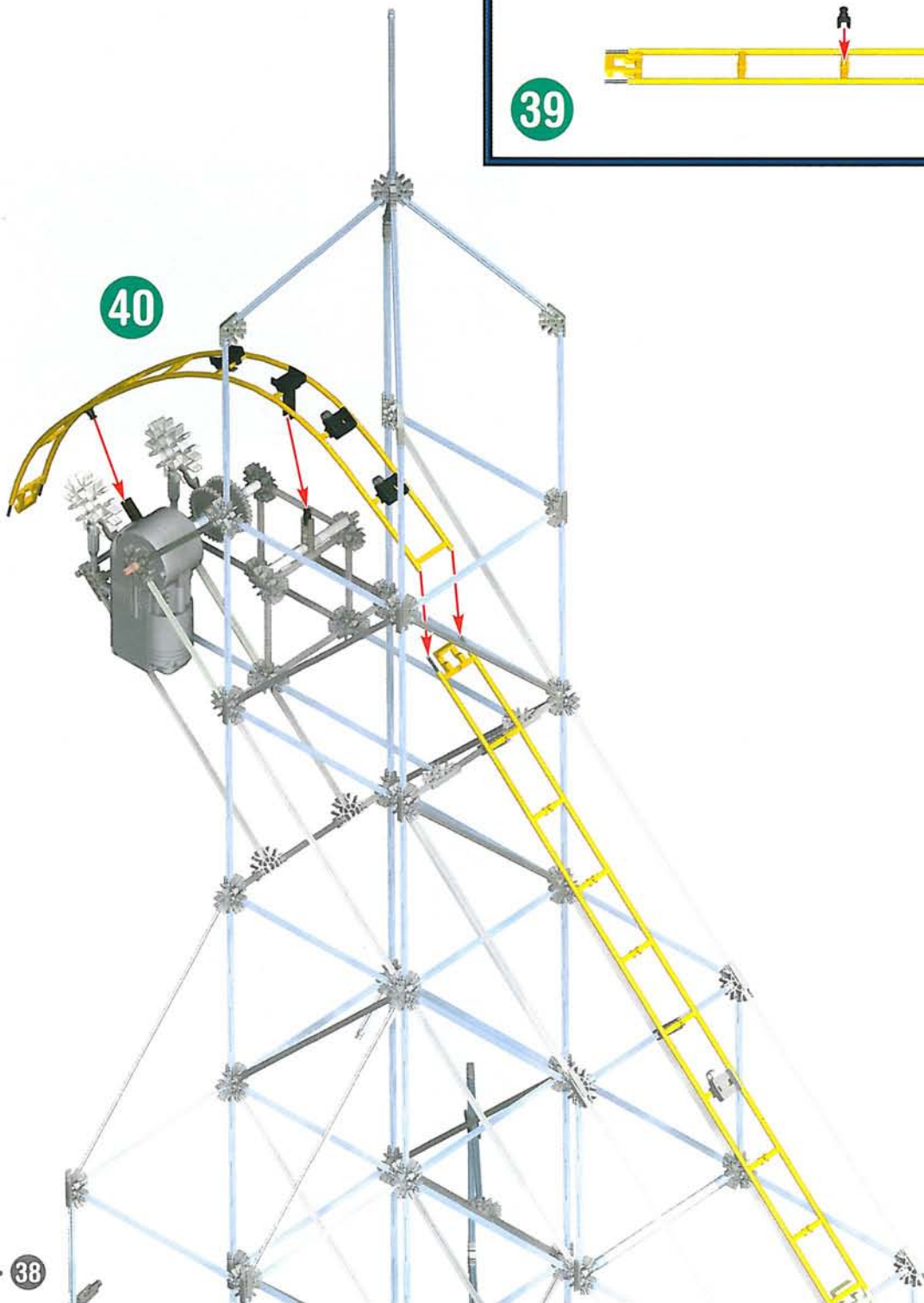
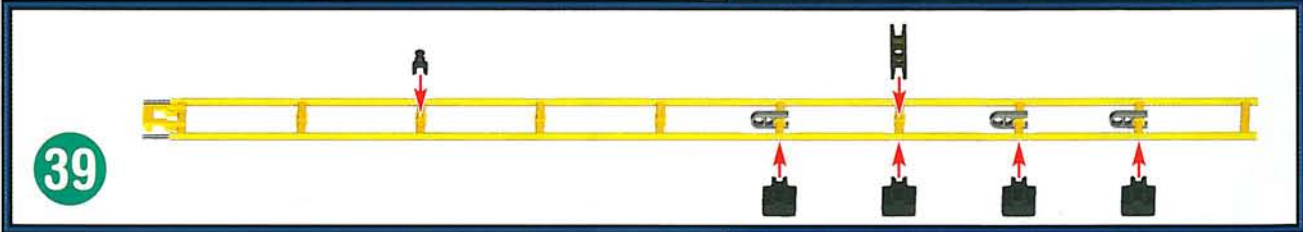

41

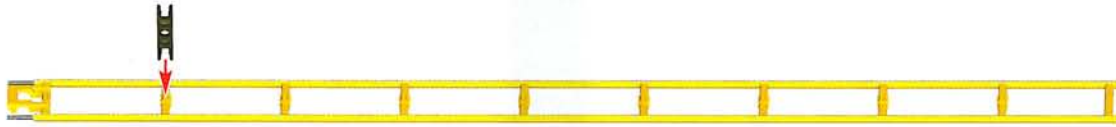

42

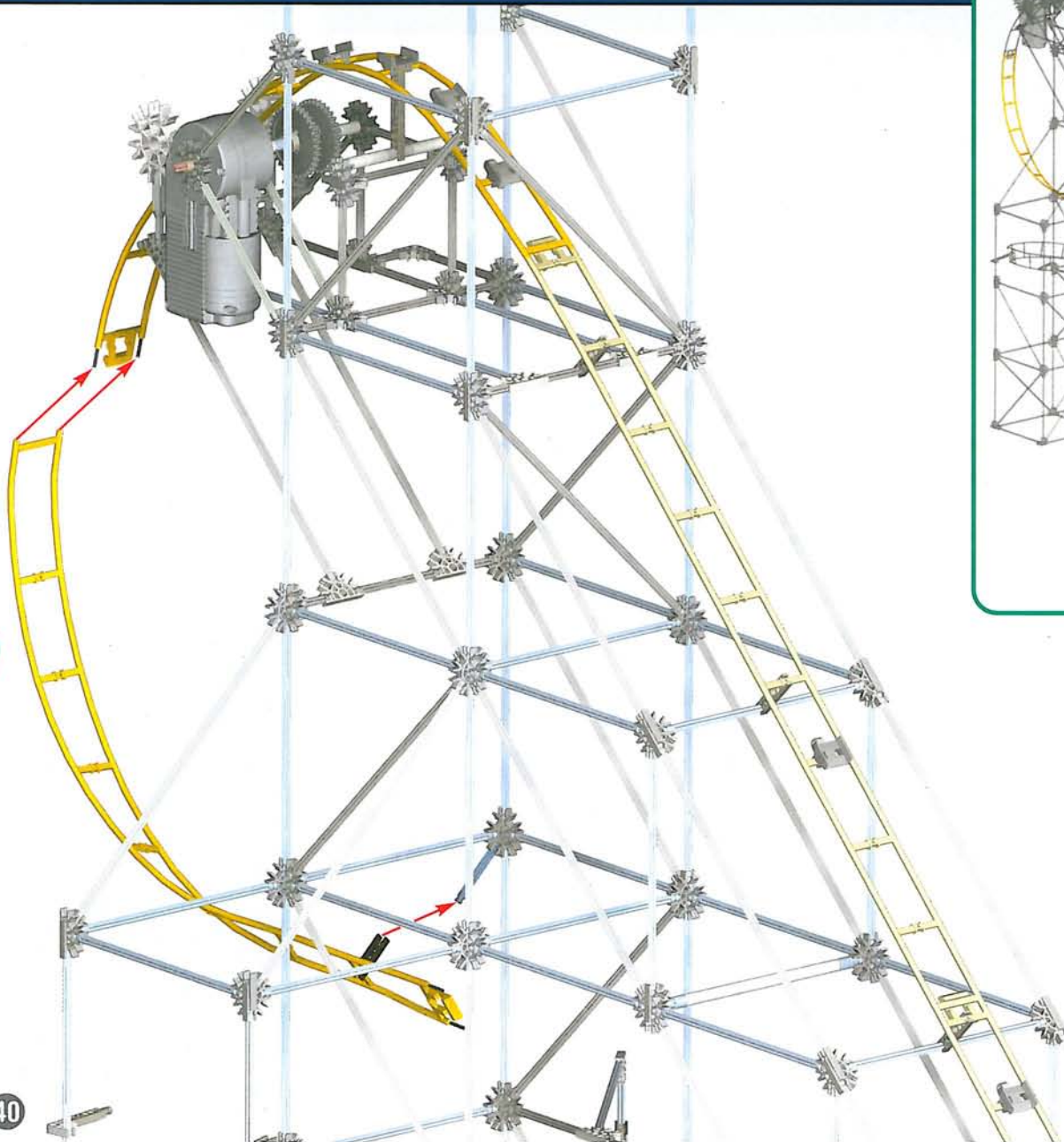

1 - 40

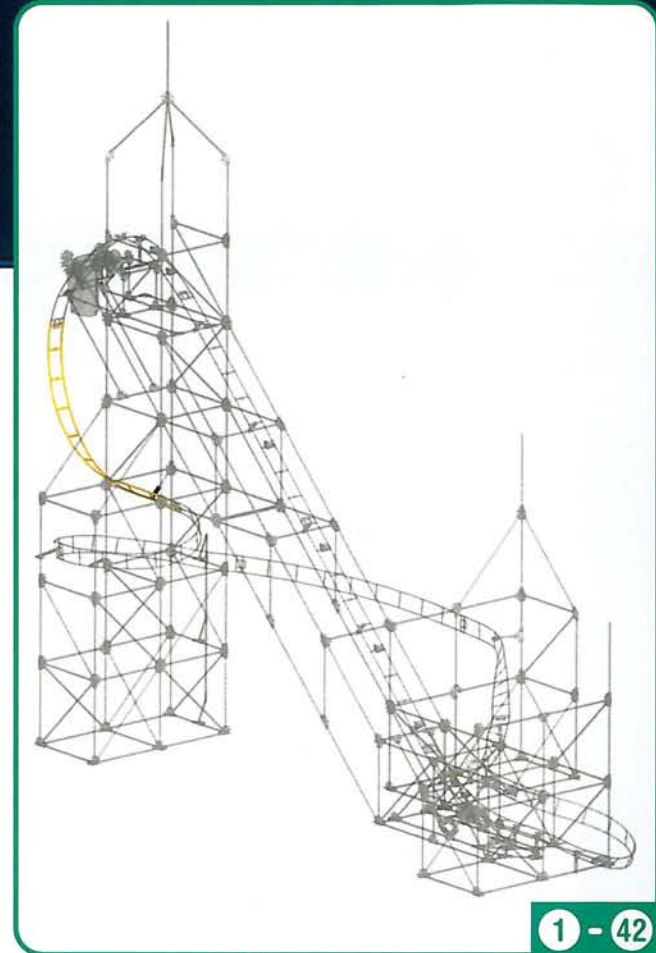

1 - 42

43

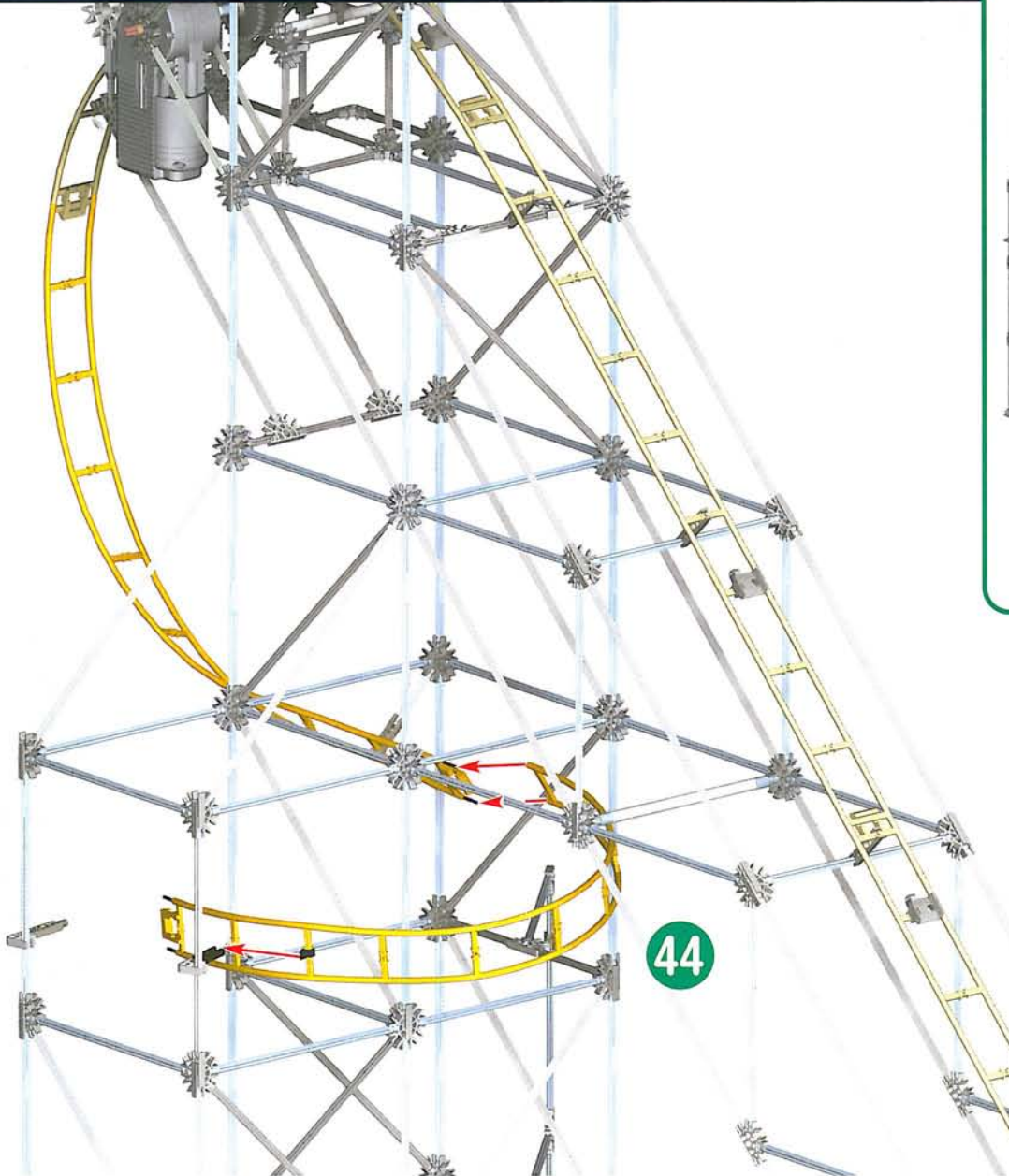
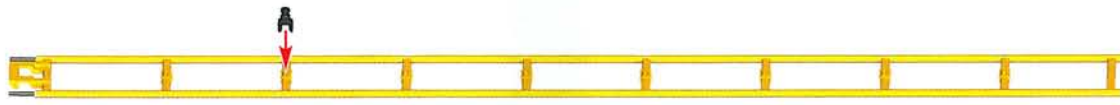

1 - 42

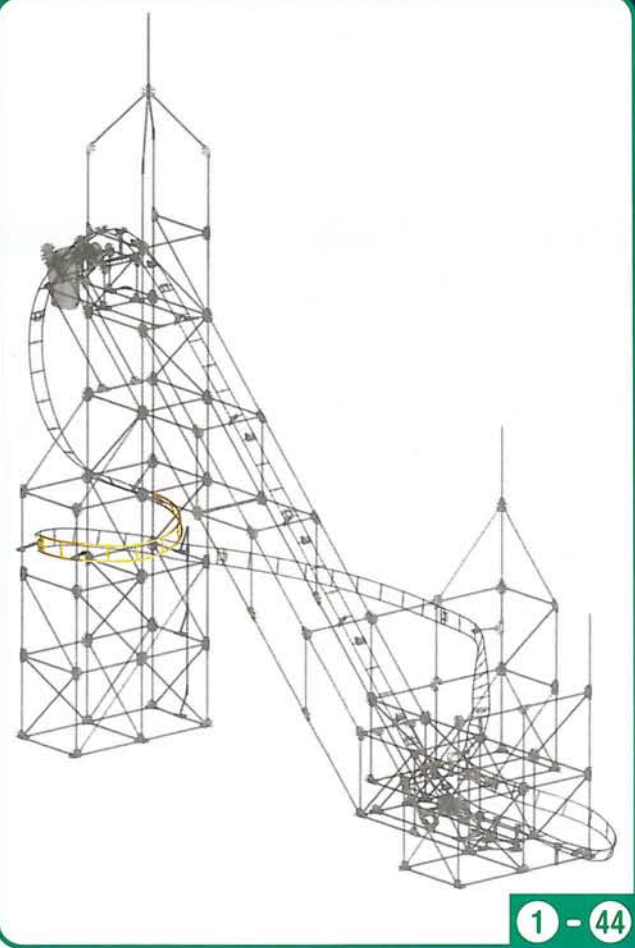

1 - 44

45



46

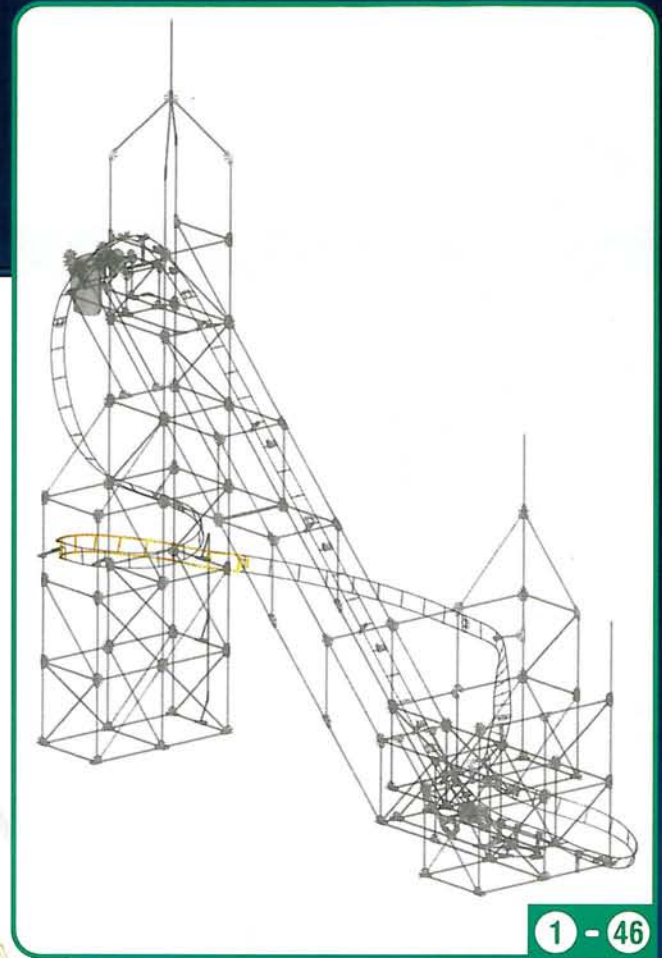
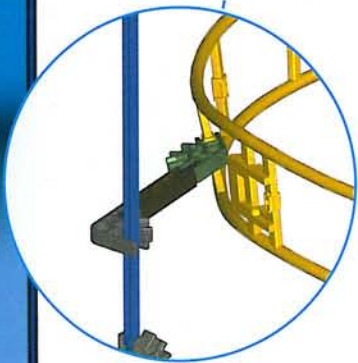
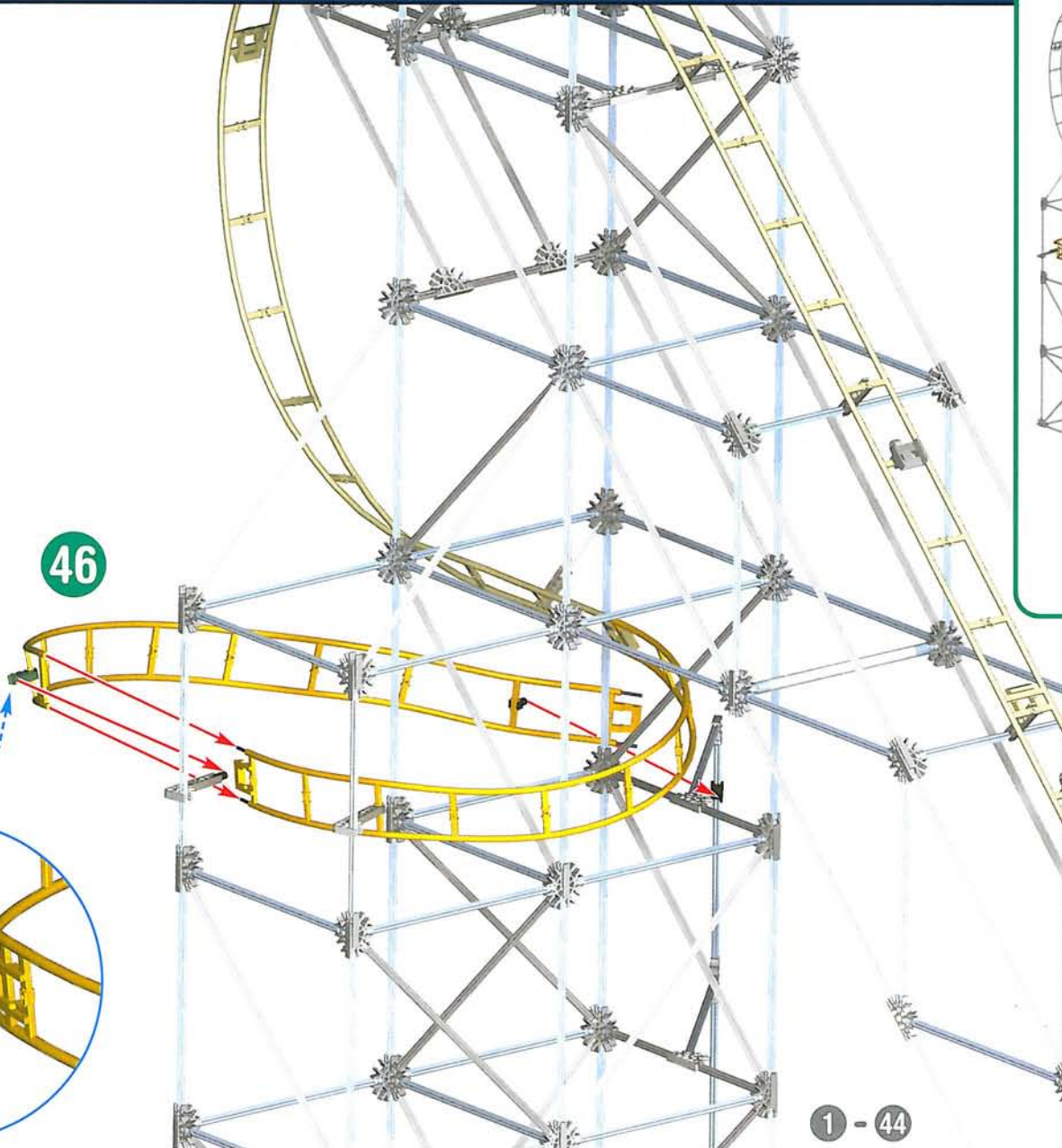

1 - 46

1 - 44

47

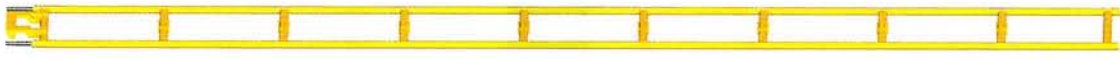

48

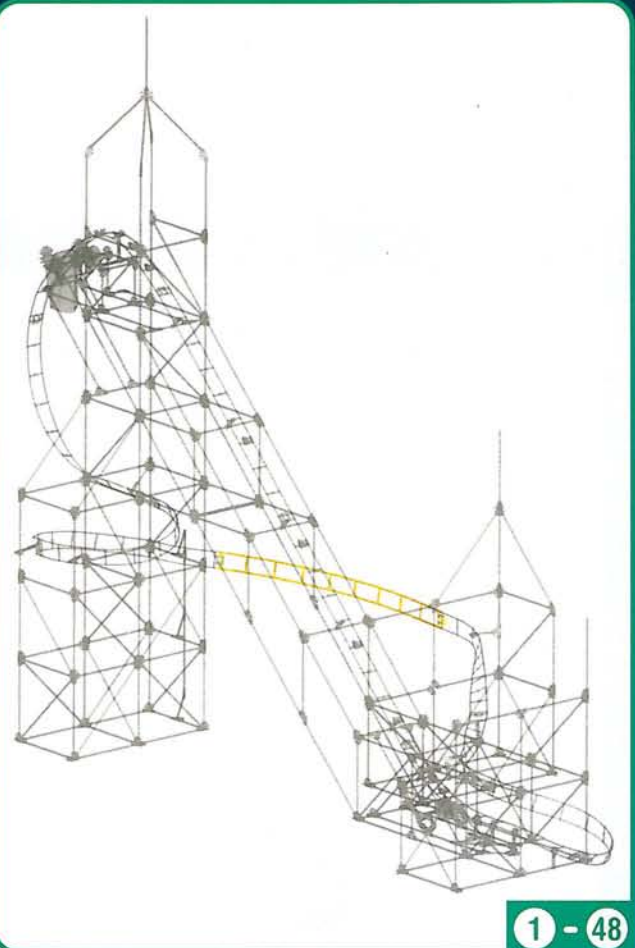
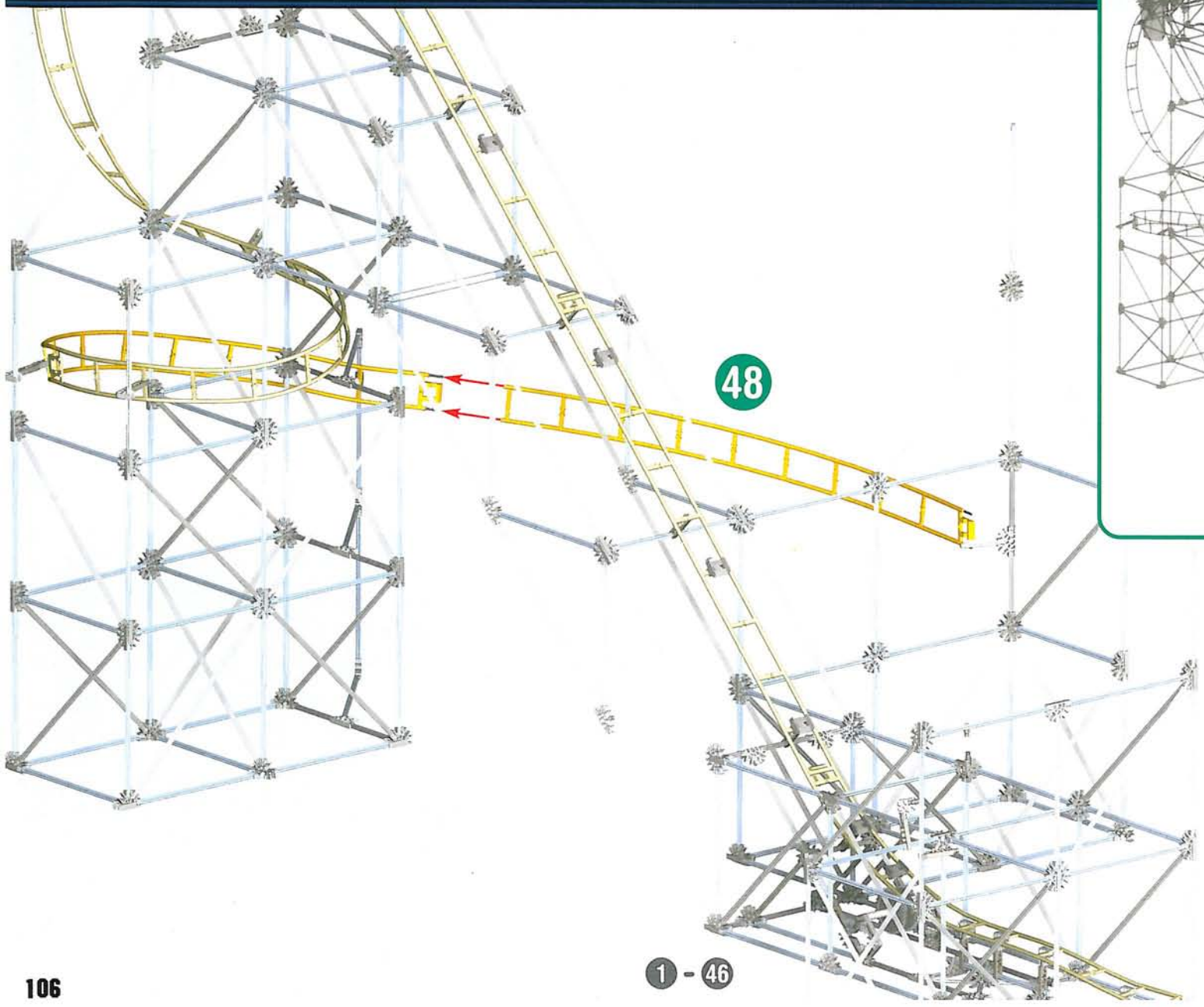

1 - 48

1 - 46

49

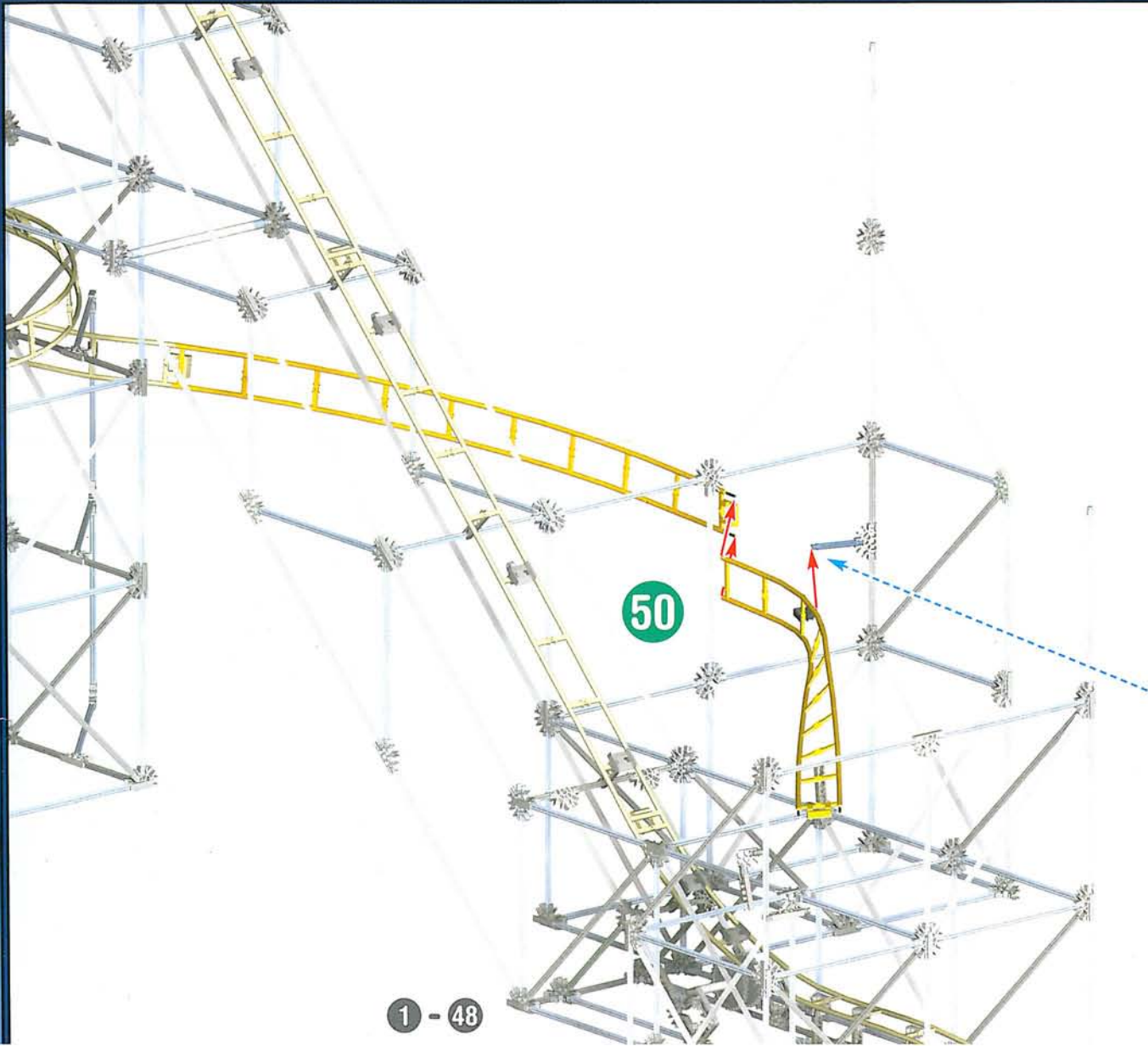
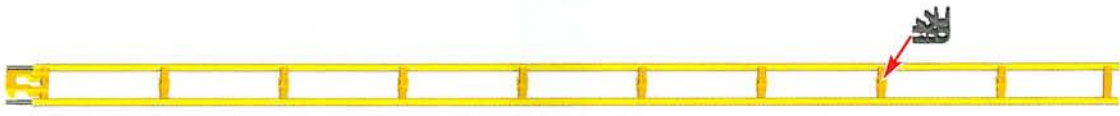

50

1 - 48

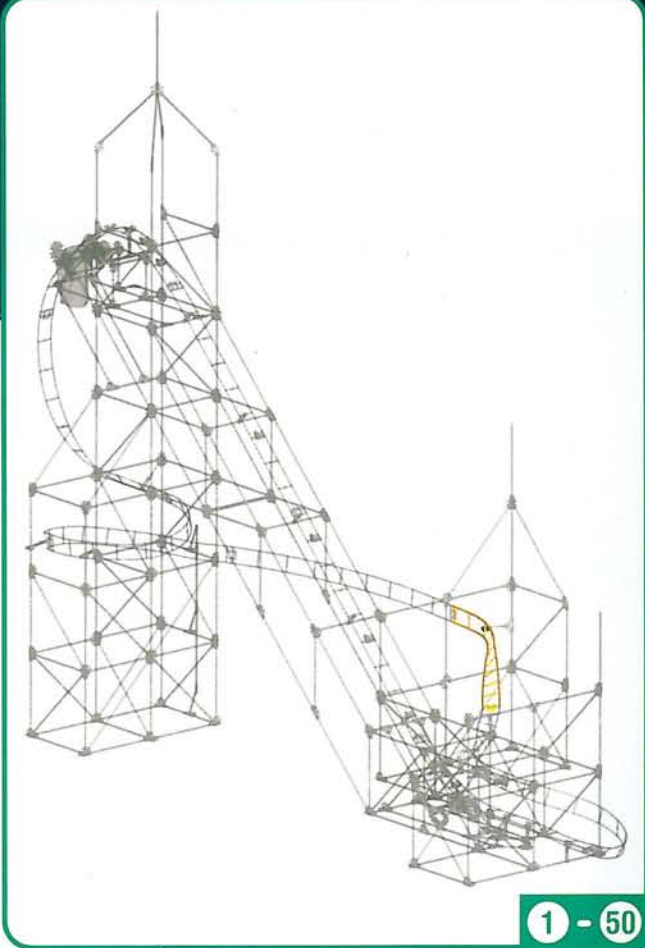

1 - 50

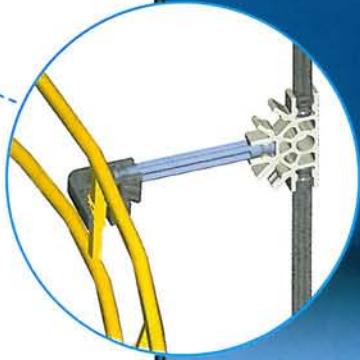

51

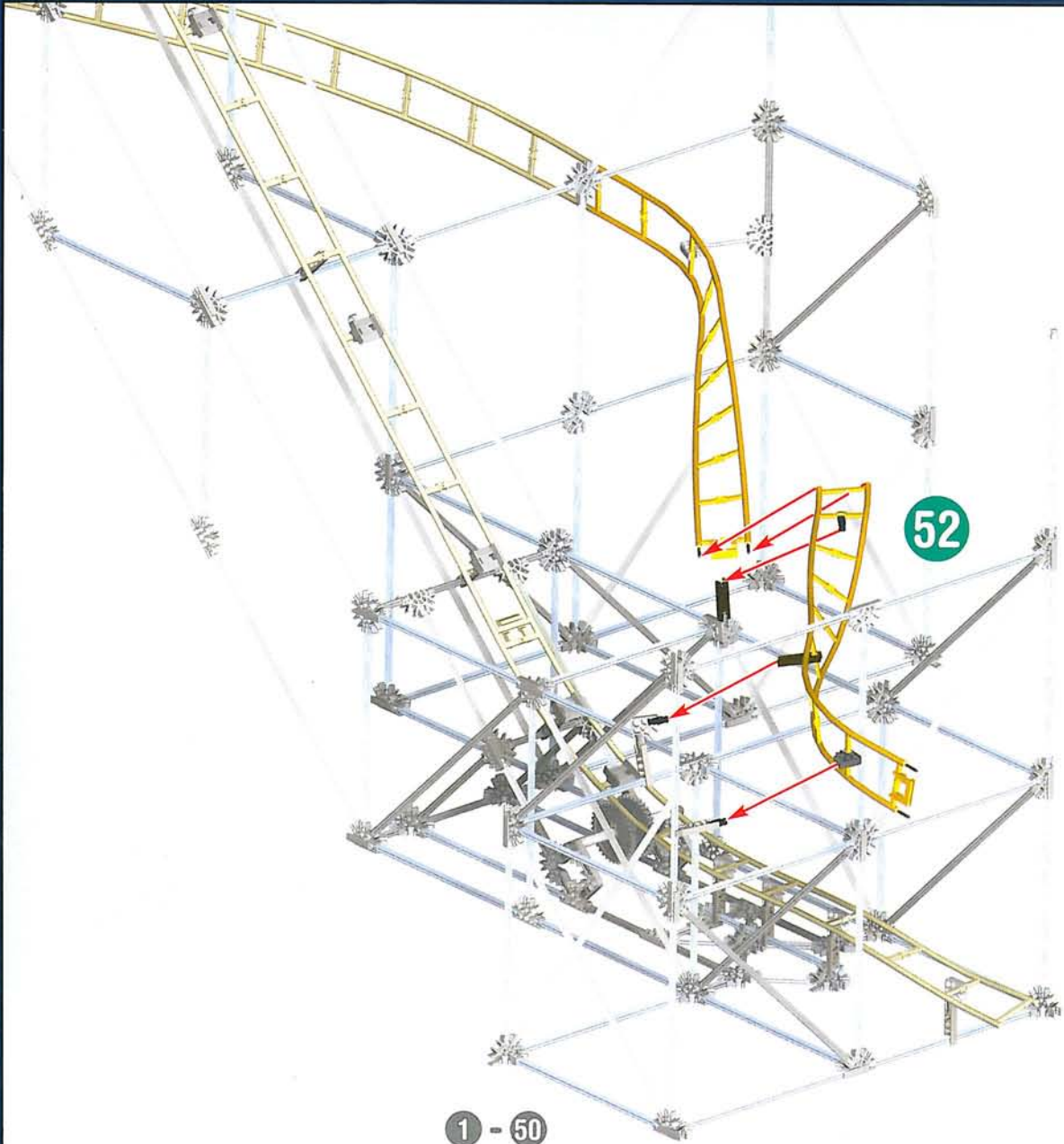
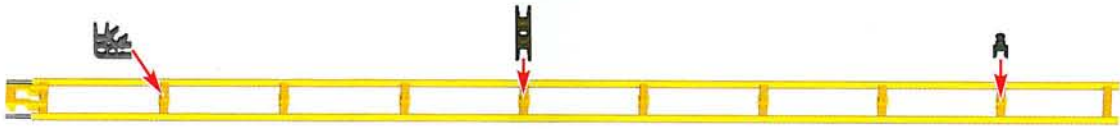

52

1 - 50

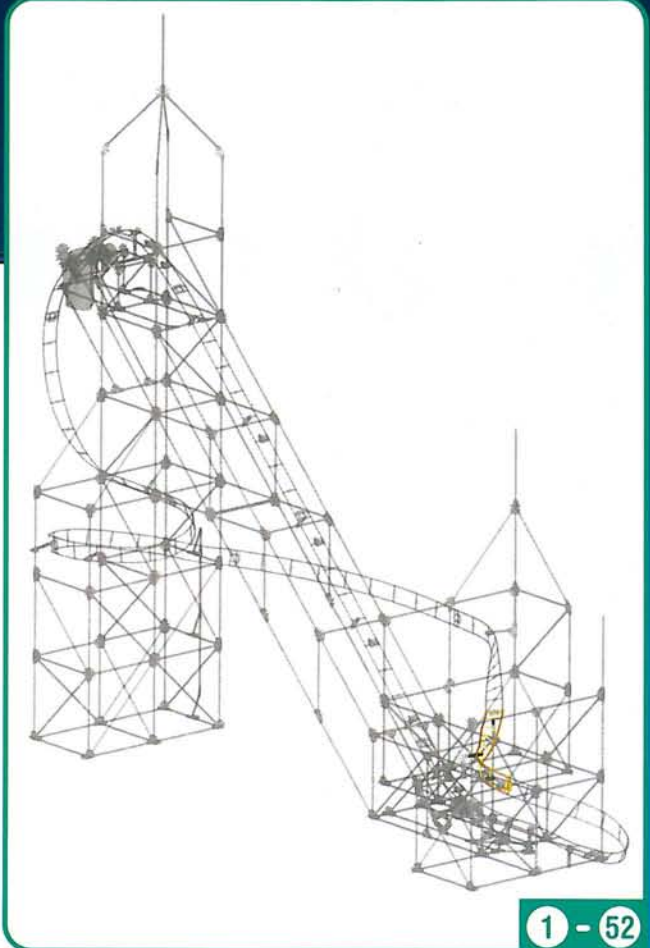

1 - 52

53

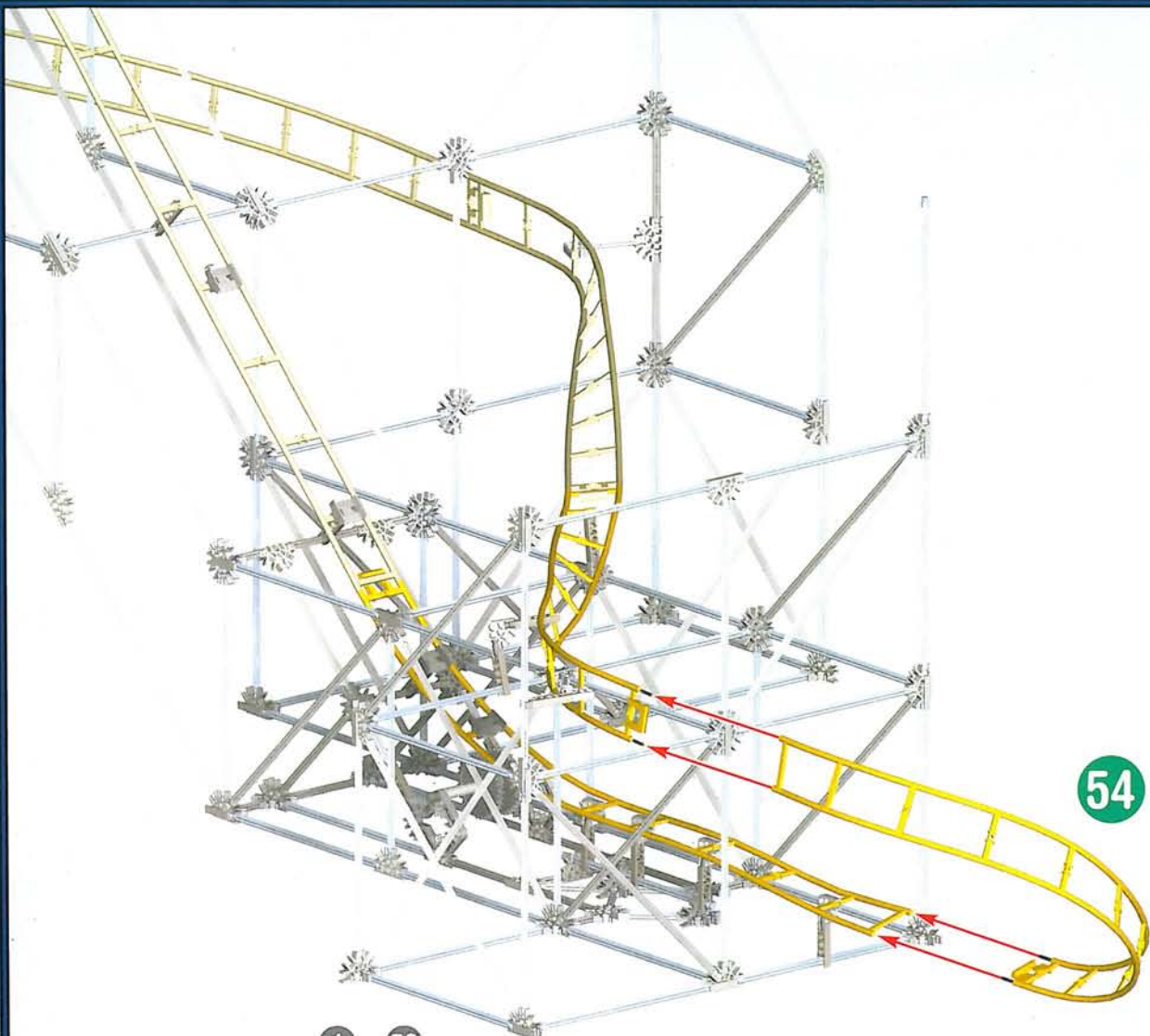

1 - 52

54

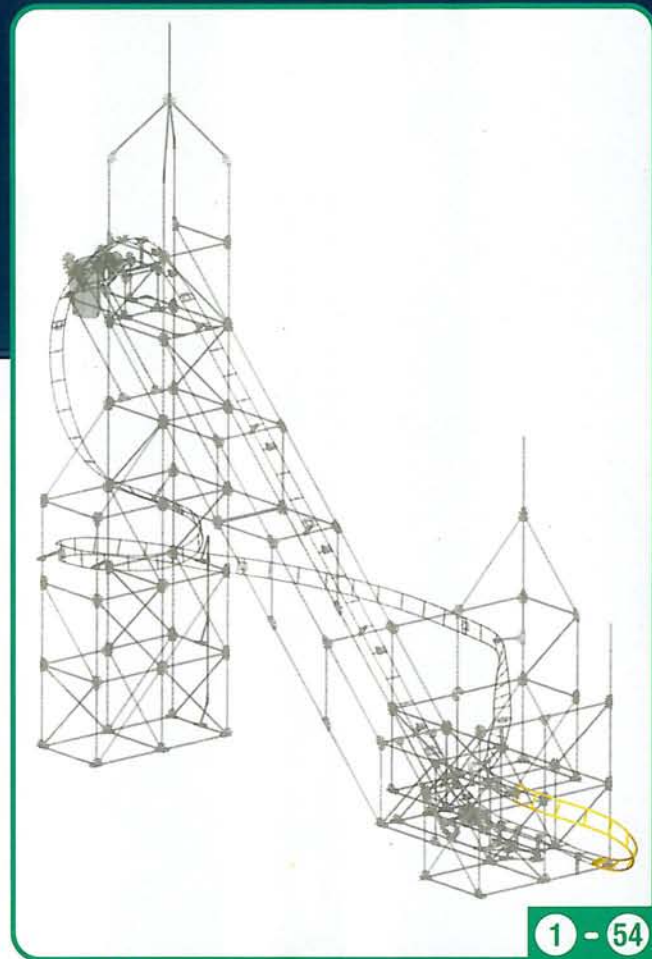

1 - 54

55



14x

56



2x



10x

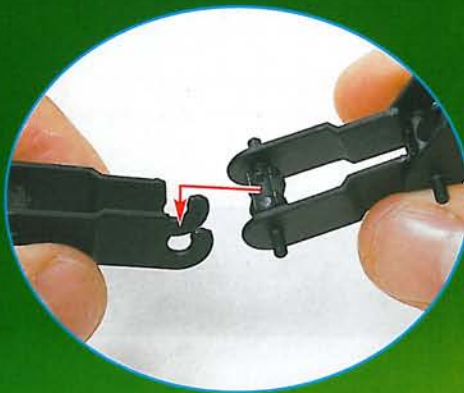

ENG IMPORTANT: Attach all the Chain Links in the same direction.

F IMPORTANT : Attache les chaînons dans le même sens.

E IMPORTANTE: Conecta los Eslabones de la Cadena en la misma dirección.

D WICHTIG: Befestige die Kettenglieder immer in die gleiche Richtung.

NL BELANGRIJK: Maak de ketenschakels vast in dexelfde richting.

I IMPORTANTE: Collegare le maglie della catena nella stessa direzione.

P IMPORTANTE: Prende os Elos da Corrente seguindo a mesma direcção.



12x

57

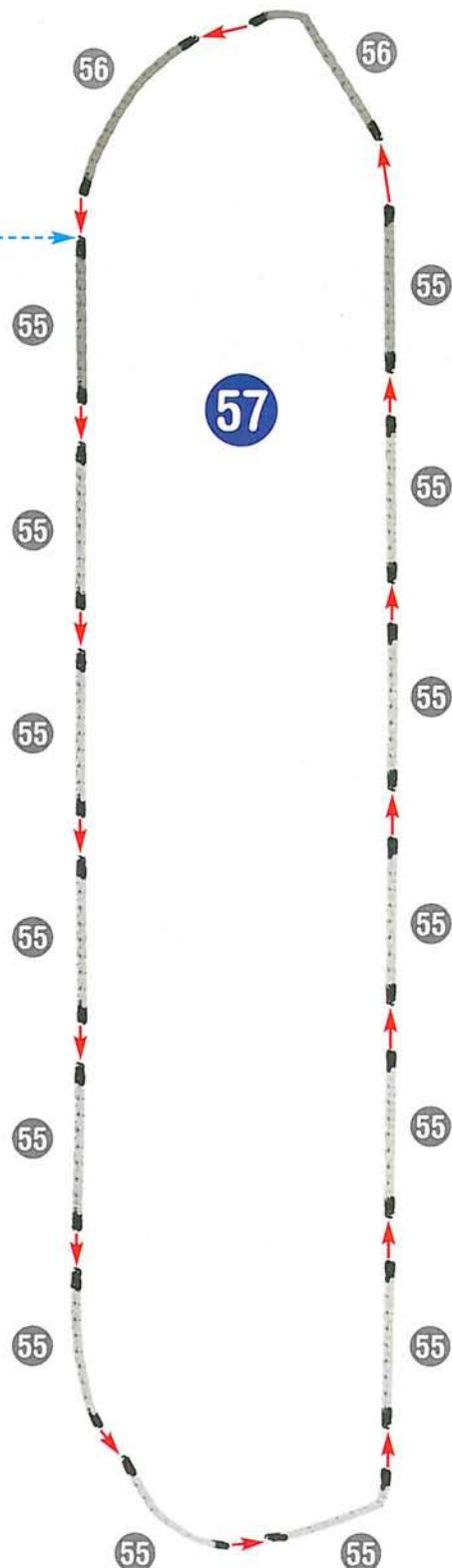



- (ENG) Chain must pass between the 2 gray Gears at the top and bottom of the coaster.
Make sure the Chain rides on the black Chain Guides.
- (F) La chaîne doit passer entre les engrenages. Veille à ce que la chaîne soit bien alignée sur les guides de chaîne.
- (E) La Cadena debe pasar entre los Engranajes. Asegúrate de que la cadena esté debidamente montada en las Guías de Cadena.
- (D) Die Kette muss wischen dem Getriebe. Achte darauf, dass die Kette auf den Kettenführungen verläuft.
- (NL) De keten moet tussen de versnellingsmechanismen. Verzeker je ervan dat de ketting op kettinggidsen loopt.
- (I) La catena deve passare fra gli ingranaggi. Accertati che la catena giri sulle guide a catena.
- (P) A Corrente dever passar entre as Engrenagens. Assegura-te de que a Corrente é montada nas respectivas Guías.

58

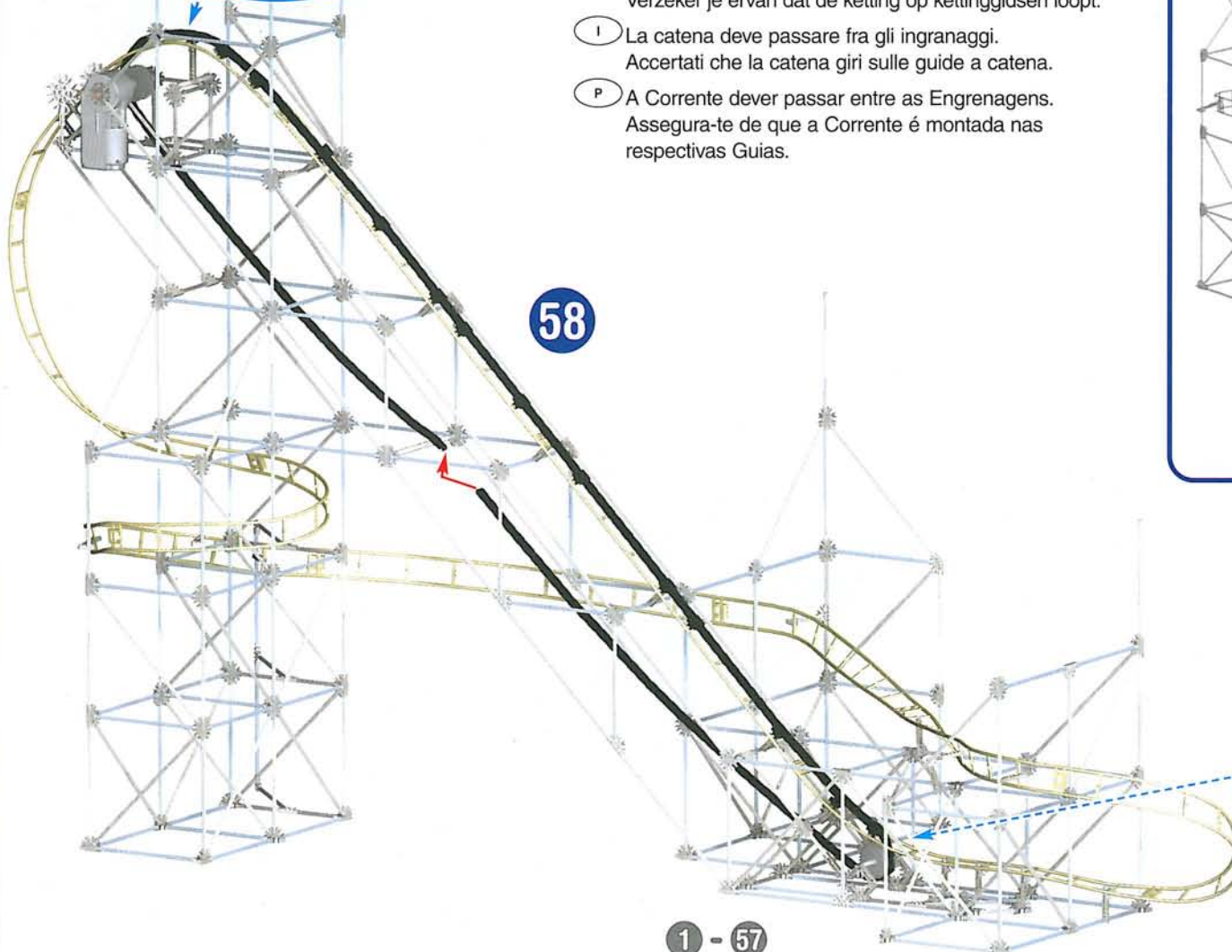

1 - 57

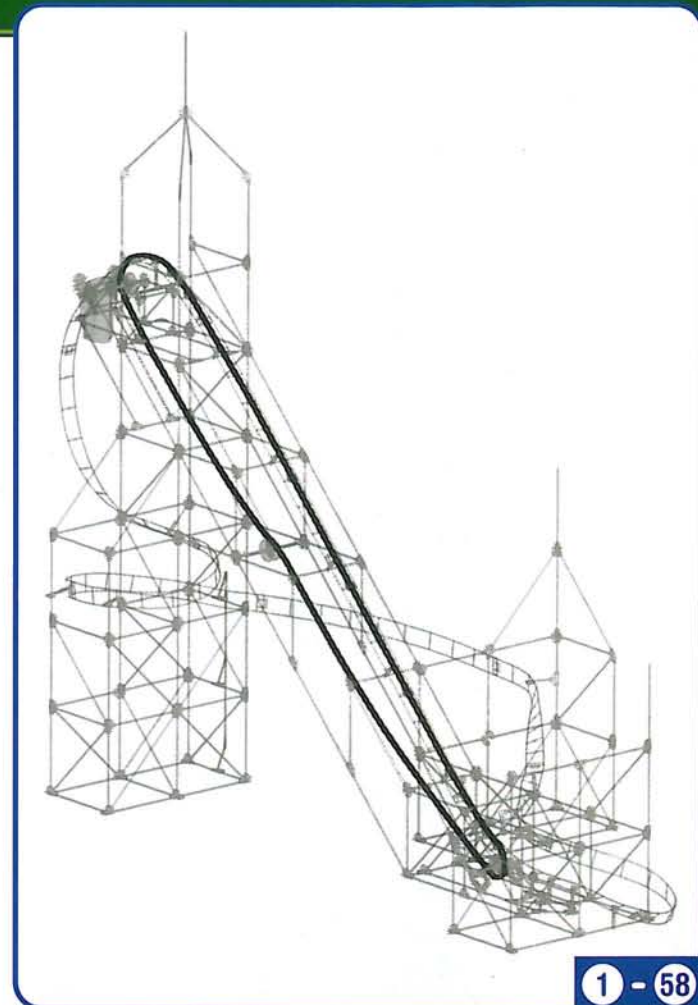

1 - 58



- The Sound Module may not work properly in direct sunlight.
- The Sound Module's sensor detects the Car's motion.
- Make sure the sensor is aligned with and facing the Reflective Sticker.
- Push the gray button on the side to activate sound. The Sound Module will shut off after 10 minutes. Push the button again to reactivate the sound.

- The Cars run on the top of the Track. To attach the Cars, slide them onto an open end of the Track.

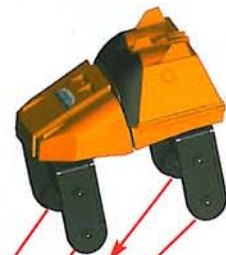

60



59



1 - 58



61

1 - 60

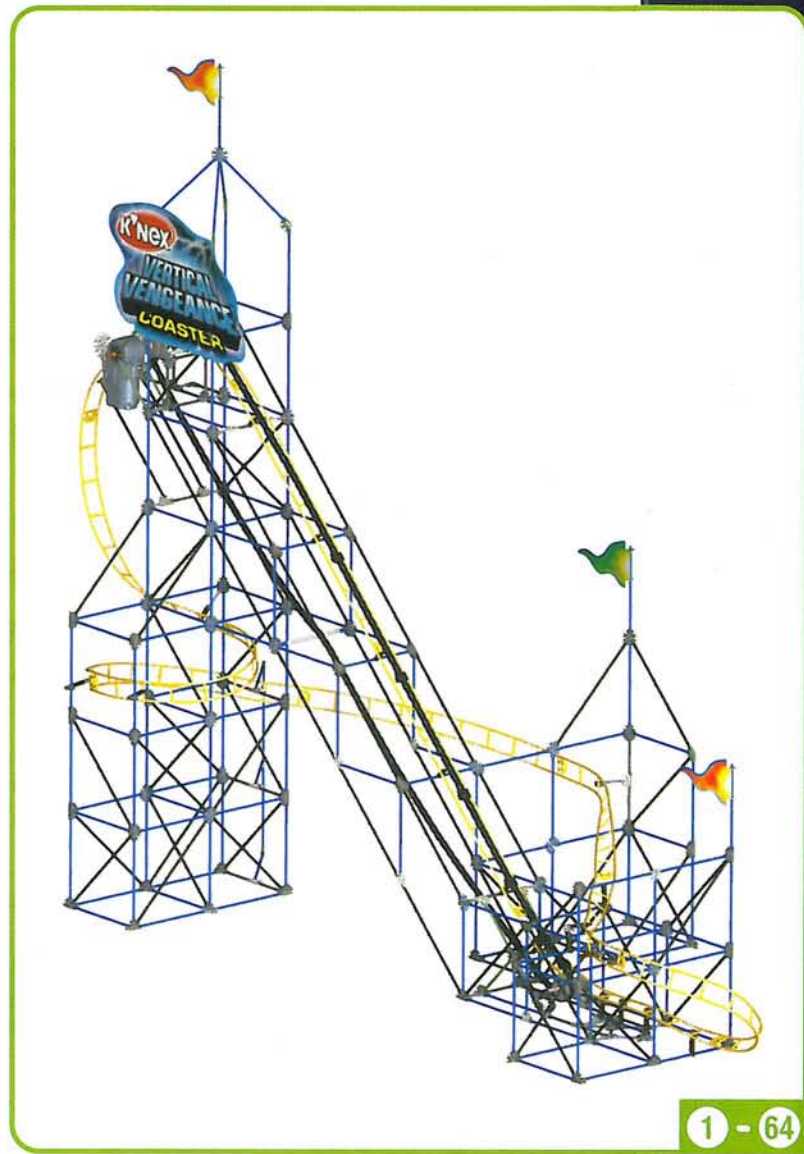
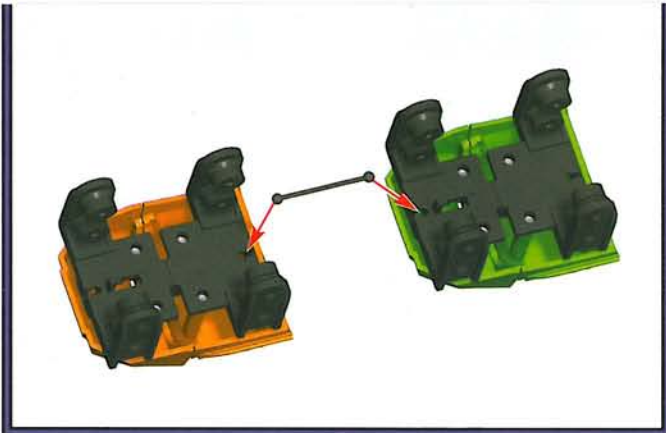
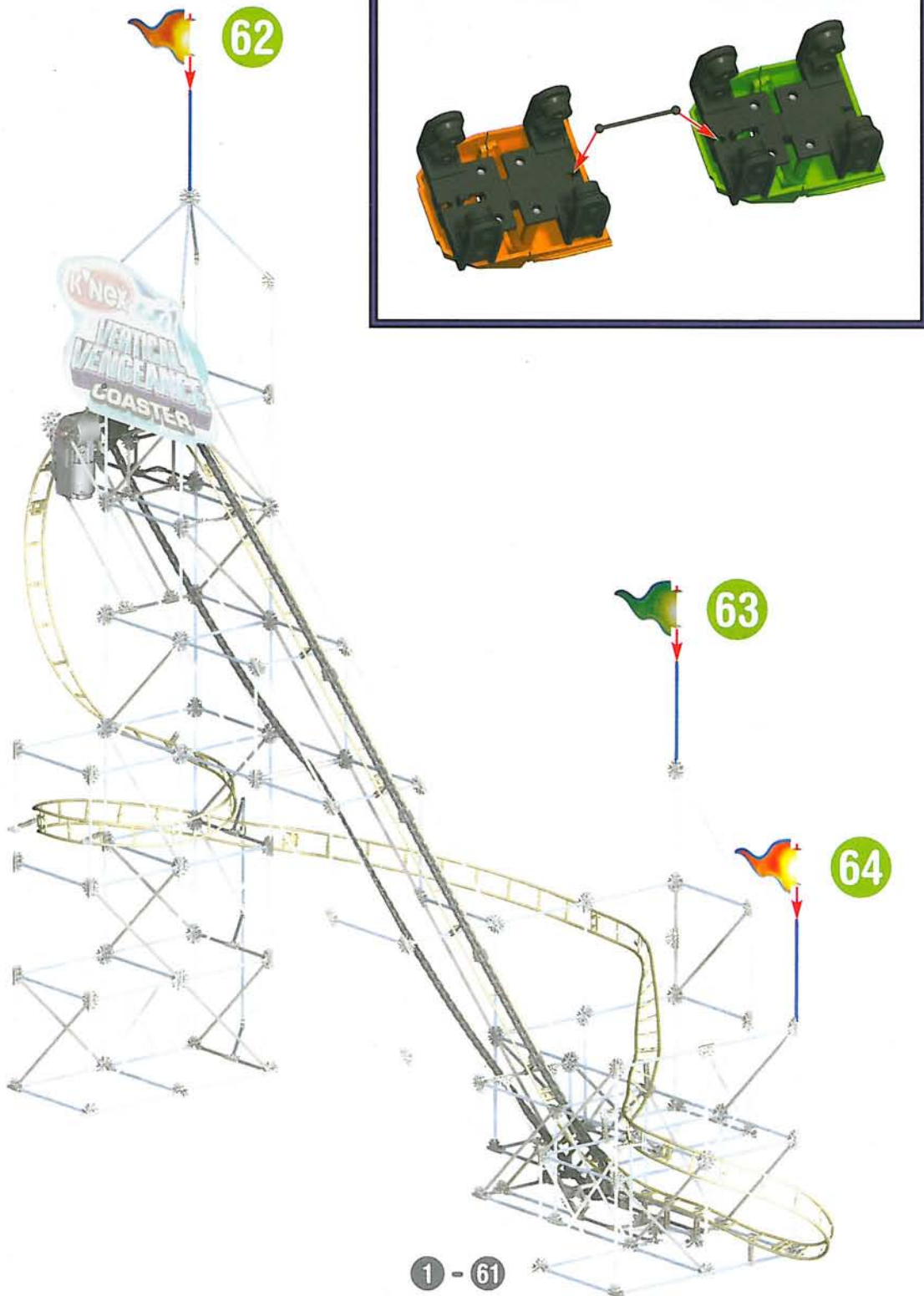

For TIPS & TROUBLESHOOTING

- Go to page 73:

Need additional building help?

- Go to the K'NEX web site:
www.knex.com/tips

(Page 2)

Construis un véritable circuit de montagnes russes qui fonctionnent pour de vrai et font 1,3 mètre de hauteur avec 10,06 mètres de circuit virevoltant. Une chaîne motorisée élève les voitures jusqu'au sommet. Regarde ensuite les voitures dégringoler vers le bas avec de véritables effets sonores de montagnes russes sans oublier les cris d'effroi !

(Page 3)

Informations importantes pour les parents et les enfants

Garde ces instructions à portée de la main. Elles comportent d'importantes informations de sécurité.

Lis tous les avertissements et les instructions avant de commencer le montage et l'exploitation du modèle.

AVERTISSEMENT : DANGER D'ÉTOUFFEMENT - Petites pièces. Ne convient pas aux enfants de moins de 3 ans.

AVERTISSEMENT : Ce produit est un produit LED de Classification 1.

ATTENTION : Garde les cheveux, les doigts, la figure et les vêtements à l'écart de toutes les pièces mobiles.

ATTENTION : Si les cheveux de l'enfant entrent en contact avec les éléments mobiles du jouet, ils risquent de s'y coincer. La supervision d'un adulte est impérative.

ATTENTION : N'utilise pas le module sonore près des oreilles. L'abus peut causer l'endommagement de l'ouïe.

- Partage l'expérience K'NEX avec ton enfant et fais du montage K'NEX un agréable projet de famille.
- Prends ton temps lors du montage. Ne te presse pas.
- L'aide d'un adulte est recommandée.
- Essaie de situer ton modèle dans le même sens que les instructions durant le montage.
- Le produit et les couleurs peuvent varier.

Informations Pile

ATTENTION :

- S'assurer d'installer les piles correctement et de suivre toujours les directives des fabricants du jouet et des piles.
- Ne pas mélanger des piles neuves avec des piles usées. Ne pas mélanger des piles alcalines avec des piles standard (Leclanché), ou des piles rechargeables (au nickel-cadmium). Il convient d'utiliser uniquement des piles du type recommandé ou d'un type équivalent.
- Retirer toujours les piles faibles ou mortes du produit ; ne pas faire court-circuiter les terminaux.
- Installer les piles en respectant la polarité (+/-) comme l'indique le schéma.

Conseils importants :

- Les piles alcalines sont recommandées.
- Il est déconseillé d'utiliser des piles rechargeables.
- Retirer les piles rechargeables du jouet avant de les recharger ; elles doivent être chargées exclusivement en présence d'un adulte.
- Les piles qui ne sont pas rechargeables ne doivent pas être rechargées.
- Veiller à ce que les éléments restent à l'abri de la poussière ; ne pas les plonger dans l'eau ; ne pas utiliser dans l'eau.
- Ne pas jeter les piles dans le feu ; elles risqueraient de fuir ou d'exploser et d'entraîner des blessures.
- Retirer toutes les piles si le jouet restera inutilisé pendant longtemps.
- Ne mettez pas les petites tiges dans les trous du moteur, elles endommageraient le moteur et il n'est pas possible de les enlever.

Comment mettre et retirer des piles

- Installe les piles dans le moteur et le module sonore avant le montage.

Moteur :

- Utilise un petit tournevis à tête cruciforme pour ouvrir le moteur. Insère les 2 piles AA neuves (ou LR6) à l'intérieur du compartiment selon la polarité correcte (+/-)

Module Sonore :

- Utilise un petit tournevis à tête cruciforme pour ouvrir le module sonore. Insère les 3 piles AAA neuves (ou LR03) à l'intérieur du compartiment selon la polarité correcte (+/-)
- Le module sonore risque ne pas marcher s'il est exposé aux rayons directs du soleil.
- Le capteur du module sonore détecte le mouvement. Assure-toi que le capteur se trouve face aux montagnes russes et à l'étiquette réfléchissante. Appuie sur le bouton noir se trouvant sur le côté pour l'activer. Le module sonore s'éteindra après 10 minutes. Appuie de nouveau sur le bouton pour le remettre en marche.

(Page 4)

Notions de base K'NEX pour le montage

"Bonjour! Je suis ton camarade de montage K'NEX. Lorsque tu me vois dans les instructions, fais très attention aux détails indiqués."

Prêt à monter

Pour commencer ton modèle, trouve le 1 et suis les chiffres. Chaque pièce a sa propre forme et sa propre couleur. Il suffit de regarder les illustrations pour retrouver les pièces correspondantes dans le jeu et de les connecter ensemble.

Suite

Les couleurs dégradées indiquent que cette section est déjà montée. Tu dois connecter la section suivante à l'endroit indiqué par les flèches. Les nouvelles pièces ajoutées auront une couleur vive.

Connecteurs

Il y a des connecteurs bleus et argentés comportant de longues fentes. Ils s'ajustent l'un dans l'autre comme l'indique l'illustration. Pousse ces pièces ensemble jusqu'à ce que tu entendes un "clic".

Entretoises

Dans ton modèle, il y a des endroits où il faudra ajouter des entretoises bleues et argentées. Assure-toi d'utiliser la couleur correcte et compte-les soigneusement.

(Page 5)

Notre garantie (US et Canada)

K'NEX Industries garantit pendant 90 jours, à compter de la date d'achat, que la VERTICAL VENGEANCE est dépourvue de tout vice de fabrication, au plan des matériaux et de la qualité de l'exécution. Si, pendant la période de garantie, une pièce s'avère défectueuse, elle sera remplacée ou réparée, nous en déciderons, gratuitement.

K'NEX n'assume aucune responsabilité en cas de dommage et/ou d'abus de votre VERTICAL VENGEANCE, et la garantie ne couvre pas de tels dégâts. K'NEX n'assumera pas non plus la responsabilité de dommage entraîné par des piles défectueuses ou trop vieilles. Des piles trop vieilles ou abîmées peuvent en effet fuir et corroder les métaux.

(Page 73)

Conseils & dépannage

Si le moteur ou le module son ne marche pas :

- Vérifie que tu as des piles neuves et qu'elles sont installées correctement.
- Si ça ne marche toujours pas, appelle notre ligne d'assistance à la clientèle à 1-800-KID-KNEX (USA et Canada uniquement). Regarde au verso pour d'autres moyens de contacter K'NEX Industries, Inc.

Si des voitures restent coincées au cours de la descente :

- Est-ce que le modèle est construit comme il faut ?
- Vérifie que la voiture ne heurte pas des pièces K'NEX.
- Est-ce que les pièces du circuit sont connectées comme il faut ?
- Est-ce que la voiture est fixée au circuit comme il faut ?
- Ajuste le circuit de façon à y éliminer des endroits plats.

(Página 2)

Construye una verdadera montaña rusa que llega a una altura de 1,3 m con 10,06 m de pista serpentina. Un elevador motorizado lleva los coches hacia arriba. ¡Luego mira los coches correr hacia abajo con verdadero sonido de montaña rusa y gritos!

(Página 3)

Información importante para los padres y niños

Guarda estas instrucciones en un sitio conveniente. Contienen información importante de seguridad.

Lee todas las advertencias e instrucciones antes de comenzar a construir y operar este modelo.

ADVERTENCIA: PELIGRO DE ASFIXIA - Piezas pequeñas. No es para niños menores de 3 años.

ADVERTENCIA: Este es un producto de Clase 1 con diodo electrolumínico.

PRECAUCIÓN: Mantén el cabello, los dedos, la cara y la ropa alejada de las piezas móviles.

PRECAUCIÓN: Si el cabello del niño entra en contacto con las partes en movimiento del juguete, puede quedar enredado. Se requiere la supervisión por un adulto.

PRECAUCIÓN: ¡No uses el Módulo de Sonido cerca del oído! El uso indebido puede producir daño al oído.

- Compartan la experiencia K'NEX con su niño y hagan que la construcción con K'NEX sea una divertida aventura de toda la familia.
- Dedicar tiempo a disfrutar el proceso de construcción. ¡No te apresures!
- Se recomienda la ayuda de un adulto.
- Mientras construyes, trata de colocar tu modelo en la misma dirección que se muestra en las instrucciones.
- El producto y los colores pueden variar.

Información acerca de las pilas

PRECAUCIÓN:

- Como con todas las pilas pequeñas, las pilas que se usan en este juguete se deben tener lejos del alcance de los niños, quienes todavía están en edad de ponerse cosas en la boca. Si estas pilas son tragadas, inmediatamente vea a un médico.
- Asegúrese de insertar las pilas correctamente y de siempre seguir las instrucciones del fabricante del juguete y de las pilas.
- No mezcle pilas viejas con nuevas, ni pilas alcalinas, estándar (carbón-cinc) o recargables (níquel-cadmio). Se debe usar solamente pilas del mismo tipo, o las que se recomienden como equivalentes.
- Siempre retire las pilas débiles o gastadas del producto; no forme cortocircuito en los puntos de intercambio.
- Inserte las pilas de acuerdo con los esquemas de polaridad (+/-).

Consejos importantes:

- Se recomiendan las pilas alcalinas.
- No se recomiendan las pilas recargables.
- Retire las pilas recargables del juguete antes de cargarlas; éstas deben ser cargadas solamente bajo la supervisión de un adulto.
- No se debe recargar las pilas que no son recargables.
- Mantenga los componentes sin polvo; no sumerja ni use en agua.
- No deseche las pilas en el fuego ya que pueden tener fugas, explotar y causar lesiones personales.
- Retire todas las pilas si el juguete no se usará por mucho tiempo.
- No meta las vainas pequeñas en los orificios del motor ya que dañarían el motor y no se podrían sacar.

Cómo insertar y quitar las pilas

- Instala todas las pilas en el Motor y el Módulo de Sonido antes de construir.

Motor:

- Usa un pequeño destornillador de estrella para abrir el Motor. Coloca 2 pilas AA (o LR6) nuevas dentro del compartimento con la polaridad correcta (+/-).

Módulo de Sonido:

- Usa un pequeño destornillador de estrella para abrir el Módulo de Sonido. Coloca 3 pilas AAA (o LR03) nuevas dentro del compartimento con la polaridad correcta (+/-).
- El Módulo de Sonido quizás no trabaje correctamente bajo la luz solar directa.
- El sensor del Módulo de Sonido detecta el movimiento. Cerciórate de que el sensor apunte hacia el carro y la Calcomanía Reflector. Para activarlo, aprieta el botón negro del lado. El Módulo de Sonido se apagará después de 10 minutos. Aprieta nuevamente el botón para activarlo.

(Página 4)

Consejos básicos de construcción de K'NEX

“¡Hola! Soy tu compañero en la construcción. Cuando me veas en las instrucciones, presta mucha atención a los detalles que se señalan.”

Todo listo, comienza a construir

Para comenzar tu modelo, busca el 1 y sigue los números. Cada pieza tiene su propia forma y color. Simplemente mira los dibujos, busca las piezas correspondientes en tu juego y después conéctalas.

Continúa

Los colores desteñidos muestran que esta sección ya está construida. Conecta las nuevas secciones en los lugares señalados por las flechas. Las nuevas piezas que agregues estarán en colores vivos.

Conectores

Hay conectores azules y plateados con ranuras largas especiales. Se enganchan deslizándose como ves en los dibujos. Conecta estas piezas empujándolas hasta que oigas “clic”.

Espaciadores

Hay lugares en tu modelo donde tendrás que agregar Espaciadores azules y plateados. Cerciórate de usar el color correcto y cuéntalos con cuidado.

(Página 73)

Consejos y solución de problemas

Si el Motor o el Módulo del Sonido no funcionan:

- Comprueba si tienes pilas nuevas y si están instaladas correctamente.
- Si aún así no trabaja, llama a nuestra Línea de Servicio al Cliente al 1-800-KID-KNEX (EE.UU. y Canadá solamente). Mira en la cubierta de atrás para otras formas de comunicarte con K'NEX Industries, Inc.

Si los coches quedan atascados mientras van hacia abajo:

- ¿El modelo está construido correctamente?
- Asegúrate de que el coche no esté golpeando ninguna de las piezas K'NEX.
- ¿Las piezas de la Pista están conectadas correctamente?
- ¿El coche está sujetado a la Pista correctamente?
- Ajusta la Pista para eliminar cualquier lugar plano que le encuentres.

(Seite 2)

Du kannst eine richtig funktionierende Achterbahn bauen, die 1,3 m hoch ist und eine kurvenreiche Strecke von 10 m hat. Ein Motor betriebener Kettenaufzug befördert die Wagen nach oben. Wenn du die Wagen nach unten brausen lässt, ertönt richtiger Sound und richtiges Schreien!

(Seite 3)

Was Eltern und Kinder unbedingt wissen sollten

Halte diese Anleitungen stets griffbereit. Sie enthalten alle wichtigen Sicherheitshinweise.

Lies bitte alle Warnhinweise und Anleitungen, bevor du mit dem Bauen und Spielen beginnst.

WARNUNG: ERSTICKUNGSGEFAHR - Vorsicht Kleinteile! Nicht für Kinder unter 3 Jahren geeignet.

WARNUNG: Dieses Spielzeug ist ein LED-Produkt der Klasse 1.

VORSICHT: Haare, Finger, Gesicht und Kleidungsstücke nicht mit beweglichen Teilen in Berührung kommen lassen.

VORSICHT: Die Haare des Kindes können in Kontakt mit bewegenden Teilen des Spielzeugs kommen und sich verfangen. Aufsicht durch Erwachsene ist erforderlich.

VORSICHT: Das Sound Modul auf keinen Fall ans Ohr oder in die Nähe des Ohrs halten! Bei falscher Anwendung kann es zu Gehörschäden kommen.

- Helfen Sie Ihrem Kind beim Bauen mit K'NEX und machen Sie aus diesem Bauprojekt ein Abenteuer mit Spaß und guter Laune für die gesamte Familie.
- Das Zusammenbauen macht Spaß, also nehmen Sie sich Zeit und hetzen Sie nicht!
- Am besten ist es, wenn Erwachsene dir dabei helfen.
- Versuche, dein Modell beim Zusammenbauen so zu orientieren, dass es in die gleiche Richtung weist, wie es in den Anleitungen beschrieben und gezeigt wird.
- Die Produkte und Farben unterscheiden sich eventuell von denen auf den Abbildungen.

Informationen zu den Batterien

VORSICHT:

- Wie alle anderen kleinen Batterien sollten auch die in diesem Spielzeug verwendeten Batterien aus der Reichweite kleiner Kinder, die noch dazu neigen, Kleinteile in den Mund zu stecken, ferngehalten werden. Nach Verschlucken sofort einen Arzt konsultieren.
- Achte darauf dass die Batterien korrekt eingelegt werden und folge den Anweisungen der Spielzeug- und Batteriefabrikanten.
- Mische keine alten und neuen Batterien oder alkaline Batterien, Standardbatterien (Kohle-Zink) oder wiederaufladbare Batterien (Nickel-Cadmium). Verwende nur Batterien des gleichen Typs oder des empfohlenen äquivalenten Typs.
- Leere oder verbrauchte Batterien aus dem Spielzeug entfernen; darauf achten, dass die Pole der Batterie nicht kurzgeschlossen werden.
- Beim Einlegen der Batterien auf die korrekte Polarität (+/-), wie dargestellt, achten.

Wichtige Tipps:

- Alkaline Batterien werden empfohlen.
- Wiederaufladbare Batterien sind nicht empfohlen.
- Bei Verwendung von wiederaufladbaren Batterien müssen diese aus dem Spielzeug entfernt werden, bevor sie wieder aufgeladen werden; das Wiederaufladen darf nur unter Aufsicht eines Erwachsenen stattfinden.
- Nichtwiederaufladbare Batterien dürfen nicht wieder aufgeladen werden.
- Die Komponenten von Staub freihalten; nicht in Wasser tauchen.
- Zu entsorgende Batterien nicht ins Feuer werfen; sie können auslaufen oder explodieren und Körperverletzungen verursachen.
- Wenn das Spielzeug längere Zeit nicht verwendet werden soll, alle Batterien entfernen.
- In keine der Öffnungen des Motor kleine Stangen einsetzen; sie beschädigen den Motor un-

können nicht entfernt werden.

Anweisungen zum Einlegen und Entfernen der Batterien

- Bevor mit dem Bauen begonnen werden kann, müssen alle Batterien in den Motor eingelegt und das Sound Modul installiert werden.

Motor:

- Das Batteriefach des Motor mit einem kleinen Kreuzschraubenzieher aufschrauben und 2 frische Batterien der Baugröße AA (oder LR6) einlegen, wobei auf den richtigen Polanschluss (+/-) zu achten ist.

Sound Modul:

- Das Batteriefach des Sound Moduls mit einem kleinen Kreuzschraubenzieher aufschrauben und 3 frische Batterien der Baugröße AAA (oder LR03) einlegen, wobei auf den richtigen Polanschluss (+/-) zu achten ist.
- Das Sound Modul funktioniert eventuell nicht einwandfrei, wenn es der direkten Sonnenbestrahlung ausgesetzt ist.
- Der Sensor des Sound Moduls reagiert auf Bewegung. Er muss deshalb die Richtung Berg- und Talbahn und den reflektierenden Aufkleber anpeilen. Mit Druck auf den schwarzen Knopf auf der Seite des Sensors kannst du ihn aktivieren. Das Sound Modul schaltet sich nach 10 Minuten automatisch aus. Um es wieder zu aktivieren, wird wieder auf den schwarzen Knopf gedrückt.

(Seite 4)

Grundlegende Bauanleitungen für K'NEX

"Hallo, ich bin dein K'NEX-Bauhelfer. Also aufgepasst, wenn ich in den Anleitungen aufkreuze! Denn dann heisst es, dass alle Anweisungen genauestens zu befolgen sind."

Auf die Plätze, fertig, los! Das Bauen beginnt

Um mit dem Bauen deines Modells zu beginnen, suche die Nummer 1 und folge den laufenden Nummern. Jedes Teil hat seine eigene Form und Farbe. Schau dir einfach die Abbildungen an, such die Teile in deinem Bausatz, die so aussehen wie das, was du auf der Abbildung siehst und steck sie ineinander.

Und weiter geht's

Blasse Farben weisen darauf hin, dass dieser Streckenabschnitt bereits zusammengebaut ist. Der neue Streckenabschnitt wird dort befestigt, worauf die Pfeile deuten. Die neuen Teile, die du anbaust, sind knallbunt angezeigt.

Steckanschlüsse

Blaue und silberfarbene Steckanschlüsse haben besonders lange Schlitze. Wie du auf der Abbildung sehen kannst, lassen sie sich ineinander schieben. Achte beim Aneinanderfügen dieser Teile darauf, dass du ein Klickgeräusch hörst. Erst dann sind die Teile fest miteinander verbunden.

Abstand Halten

An bestimmten Stellen in deinem Modell musst du Abstandshalter, sogenannte Spacer, einbauen. Diese Abstandshalter sind blau und silberfarben. Achte darauf, dass du die richtige Farbe wählst und dass du die richtige Anzahl davon verwendest.

(Seite 73)

Tipps und Fehlerbehebungen

Falls der Motor oder das Soundmodul nicht funktionieren:

- Überprüfe, ob die Batterien voll sind und richtig eingelegt sind.
- Falls es immer noch nicht funktioniert, kannst du innerhalb der USA und Kanadas unsere Hotline anrufen (Tel. 1-800-KID-KNEX). Auf der Rückseite dieser Anleitung findest du – weitere Möglichkeiten, K'NEX Industries, Inc. zu kontaktieren.

Falls die Wagen bei der Abfahrt stecken bleiben:

- Ist das Modell richtig zusammengebaut?
- Überprüfe, ob der Wagen gegen einzelne Bauteile stößt.
- Sind die Schienenstücke richtig miteinander verbunden?
- Sitzt der Wagen richtig auf den Schienen?
- Ändere den Schienenverlauf so, dass die Wagen immer genügend Schwung haben.

(Bladzijde 2)

Bouw een echt werkende roetsjbaan van meer dan 1,3 m hoog, volledig met een 10,06 m lang kronkelend spoor. Een kettinglift met motor brengt de wagens naar boven. Kijk dan hoe de wagens naar beneden duiken met echte roetsjbaangeluiden en – geschreeuw !

(Bladzijde 3)

Belangrijke gegevens voor ouders en kinderen

Bewaar deze aanwijzingen op een gemakkelijk bereikbare plaats. Ze bevatten belangrijke veiligheidsgegevens.

Gelieve alle waarschuwingen en aanwijzingen te lezen vóór je het model begint op te bouwen en te gebruiken.

WAARSCHUWING: VERSTIKKINGSGEVAAR - Kleine onderdelen. Niet geschikt voor kinderen onder 3 jaar.

WAARSCHUWING: Dit is een LED-product van de 1 categorie.

OPGEPAST: Hou het haar, de vingers, het gezicht en kledij verwijderd van alle bewegende onderdelen.

OPGEPAST Als het haar van het kind in aanraking komt met bewegende onderdelen van het speelgoed kan het haar verstrikt raken. Toezicht van een volwassene is vereist.

OPGEPAST: Gebruik de geluidsmodule niet kort bij je oren. Ongepast gebruik ervan kan je gehoor beschadigen.

- Deel de K'NEX ondervinding met je kind en maak van het bouwen met K'NEX een aangenaam familieavontuur.
- Neem je tijd tijdens het bouwen en monteren. Spoed je niet!
- Bijstand van een volwassene wordt aanbevolen.
- Tracht je model in dezelfde richting te plaatsen als de aanwijzingen terwijl je bouwt en monteert.
- Produkt en kleuren kunnen afwijken.

Batterijgegevens

OPGEPAST:

- Zoals het geval is voor alle kleine batterijen, moeten de batterijen voor dit speelgoed buiten het bereik gehouden worden van kleine kinderen die nog steeds voorwerpen in de mond steken. Ingeval een batterij wordt ingeslikt, neem onmiddellijk contact op met een dokter.
- Verzeker je ervan dat de batterijen er op de juiste manier in te steken en volg steeds de aanduidingen van de speelgoed- en batterijenfabrikanten.
- Meng geen oude en nieuwe batterijen of alkalische, gewone (koolstof-zink) of herlaadbare (nikkel-cadmium) batterijen met mekaar. Uitsluitend batterijen van dezelfde of van een aanbevolen equivalent soort dienen gebruikt te worden.
- Verwijder steeds uitgeputte of ontladen batterijen uit het produkt; veroorzaak geen kortsluiting van de voedingspolen.
- Steek de batterijen erin volgens de juiste polariteit (+/-) zoals afgebeeld.

Belangrijke tips

- Alkalische batterijen worden aanbevolen.
- Herlaadbare batterijen worden niet aanbevolen.
- Verwijder herlaadbare batterijen uit het speelgoed alvorens ze te herladen; ze moeten slechts herladen worden onder het toezicht van een volwassene.
- Niet-herlaadbare batterijen mogen niet herladen worden.
- Bescherm onderdelen tegen stof; dompel ze niet of gebruik ze niet in water.
- Werp de batterijen niet in het vuur; ze zouden kunnen lekken of ontploffen en verwondingen veroorzaken.
- Verwijder alle batterijen wanneer het speelgoed gedurende lange tijd niet gebruikt zal worden.

- Plaats staafjes in de openingen van het motor, zij zouden de motor beschadigen en kunnen niet worden verwijderd.

Insteken en verwijderen van batterijen

- Installeer alle batterijen in de Motor en in de geluidsmodule vóór je begint te bouwen.

Motor:

- Gebruik een kleine schroevendraaier met kruiskop om de Motor te openen. Steek 2 nieuwe AA (of LR6) batterijen in de batterijenruimte volgens de gepaste polariteit (+/-).

Geluidsmodule:

- Gebruik een kleine schroevendraaier met kruiskop om de geluidsmodule te openen. Steek 3 nieuwe AAA (of LR03) batterijen in de batterijenruimte volgens de gepaste polariteit (+/-).
- De geluidsmodule werkt eventueel niet wanneer ze is blootgesteld aan rechtstreekse zonnelicht.
- De sensor van de geluidsmodule merkt beweging op. Verzeker je ervan dat de sensor gericht is naar de roetsjbaan en naar de weerkaatsende sticker. Druk op de zwarte knop op de kant om de module aan te zetten. De geluidsmodule zal zich na 10 minuten stilzetten. Druk op de knop om ze terug aan te zetten.

(Bladzijde 4)

Basisstappen voor K'NEX bouwen

“Hoi! Ik ben je K'NEX bouwvriend. Wanneer je me in de aanwijzingen ziet, gelieve volledige aandacht te geven aan de details die worden aangeduid.”

Klaar om te bouwen

Om met je model te beginnen, vind eerst het nummer 1 en volg de nummers. Elk stuk heeft zijn eigen vorm en kleur. Kijk gewoonweg naar de afbeeldingen, vind de overeenstemmende stukken terug in je geheel en maak ze aan mekaar vast.

Verder nog

De vervaagde kleuren duiden aan dat dit deel reeds is opgebouwd. Gelieve het nieuwe deel vast te koppelen op de plaats aangeduid door de pijlen. De nieuwe delen die je toevoegt verschijnen in volle kleur.

Connecteurs

Il y a des connecteurs bleus et zilveren comportant de longues fentes. Ils s'ajustent l'un dans l'autre comme l'indique l'illustration. Pousse ces pièces ensemble jusqu'à ce que tu entendes un "clic".

Tussenstukken

In je model zijn er plaatsen waar blauwe en zilveren tussenstukken moeten toegevoegd worden. Verzeker je ervan de juiste kleur te gebruiken en tel ze zorgvuldig.

(Bladzijde 73)

Tips & Oplossen van problemen

Wanneer de motor- of klankmodule niet werkt:

- Kijk na dat je nieuwe batterijen hebt en dat ze er behoorlijk zijn aangebracht.
- Werkt het nog steeds niet, bel dan de Klantendienst Hotline op aan het nummer 1-800-KID-KNEX (uitsluitend in de VS en Canada). Kijk naar het achterblad voor andere manieren om contact op te nemen met K'NEX Industries, Inc.

Wanneer wagens vastlopen tijdens de daling:

- Is het model behoorlijk opgebouwd?
- Verzeker je ervan dat de wagen tegen geen K'NEX onderdelen aanloopt.
- Zijn de spoorstukken behoorlijk verbonden?
- Is de wagen behoorlijk aan het spoor verbonden?
- Ajusteer het spoor om platte stukken op het spoor te verwijderen.

(Pagina 2)

Costruisci delle vere e proprie montagne russe che raggiungono 1,3 metri di altezza, complete di 10, 06 metri di rotaia serpeggiante e piena di curve. Un montacarichi a catena motorizzato porta le carrozze sulla cima. Quindi osserva le carrozze correre fino alla base con suoni da vere montagne russe e grida!

(Pagina 3)

Informazioni importanti per bambini e genitori

Tenere queste istruzioni a portata di mano. Contengono importanti informazioni di sicurezza.

Leggere tutte le avvertenze e le istruzioni prima di iniziare a costruire il modello e di farlo funzionare.

AVVERTENZA: PERICOLO DI SOFFOCAMENTO - Piccole parti. Non adatto a bambini di età inferiore ai 3 anni.

AVVERTENZA: Questo è un prodotto di classe 1 LED.

ATTENZIONE: Tenere i capelli, le dita, il viso e i vestiti lontano da tutte le parti in movimento.

ATTENZIONE: I capelli del bambino potrebbero impigliarsi se vengono a contatto con le parti del giocattolo in movimento. È richiesta la supervisione di un adulto.

ATTENZIONE: Non usare il modulo del suono vicino alle orecchie! Un uso improprio potrebbe causare danni all'udito.

- Condividi l'esperienza di K'NEX con tuo figlio e rendi la costruzione con K'NEX un divertimento per tutta la famiglia.
- Prendi il tempo necessario per divertirti durante il processo di costruzione. Non ti affrettare!
- Si raccomanda l'aiuto di un adulto.
- Orienta il tuo modello nella stessa direzione indicata nelle istruzioni.
- Il prodotto e i colori possono variare.

Informazioni sulle batterie

ATTENZIONE:

- Come per tutte le batterie piccole, le batterie utilizzate in questo giocattolo devono essere tenute lontano dalla portata dei bambini piccoli, che mettono ancora oggetti in bocca.
- Accertarsi di inserire le batterie correttamente e seguire sempre le istruzioni del produttore delle batterie e del giocattolo.
- Non mettere insieme batterie nuove e vecchie o alcaline, standard (carbonio-zinco) e ricaricabili (nichel-cadmio). Usare sempre batterie raccomandate dello stesso tipo o di tipo equivalente.
- Rimuovere sempre batterie quasi scariche o completamente scariche dal prodotto; non causare corto circuito ai terminali di alimentazione.
- Inserire le batterie con la polarità corretta (+/-) come illustrato.

Consigli importanti

- Si raccomanda l'uso di batterie alcaline.
- Non si raccomanda l'uso di batterie ricaricabili.
- Rimuovere le batterie ricaricabili dal giocattolo prima della carica: devono essere caricate solo sotto la supervisione di un adulto.
- Le batterie non ricaricabili non devono essere ricaricate.
- Mantenere i componenti privi di polvere; non immergere o usare in acqua.
- Non gettare le batterie nel fuoco, poiché potrebbero perdere o esplodere e causare lesioni.
- Rimuovere tutte le batterie se il giocattolo non verrà usato per un lungo periodo di tempo.

- Non inserire aste più corte di 5,1 cm (2 pollici) nei fori del motore, in quanto danneggerebbero il motore e non possono essere rimosse.

Come inserire e rimuovere le batterie

Motore:

- Usare un piccolo giravite a stella per allentare la vite e quindi rimuovere lo sportello delle batterie. Inserire 2 batterie a bottone nuove LR6 nell'alloggiamento delle batterie con la polarità corretta (+/-).

Modulo del Suono:

- Usare un piccolo giravite a stella per allentare la vite e quindi rimuovere lo sportello delle batterie. Inserire 3 batterie a bottone nuove LR03 nell'alloggiamento delle batterie con la polarità corretta (+/-).

(Pagina 4)

Istruzioni di base per costruire con K'NEX

"Ciao, sono il tuo amico costruttore K'NEX. Quando lei me vede nelle istruzioni, lei vorrà pagare l'attenzione vicina all'essere di dettagli ha evidenziato."

Pronti, Partenza, Via alla costruzione

Per iniziare il modello, cerca il numero 1 e segui i numeri. Ogni pezzo ha una sua forma e un suo colore. Guarda la figura, trova i pezzi corrispondenti nel set e mettili insieme. Cerca di tenere il modello nella stessa direzione della figura e in tal modo sarà più semplice attaccare i pezzi nei posti giusti.

Andiamo avanti

I colori spenti ti dicono che questa sezione è già stata costruita. Dovrai collegare la nuova sezione al punto indicato dalla punta della freccia. Questo pezzo avrà un colore brillante.

Connettori

È molto importante posizionare i connettori blu e argento in una specifica direzione. Presta molta attenzione alle istruzioni e posiziona i connettori orizzontalmente o verticalmente proprio come illustrato. Spingi con forza fino ad udire un clic.

Spaziatori

Ci sono punti nel tuo modello a cui dovrai aggiungere spaziatori blu e argento. Accertati di contarli attentamente.

(Pagina 73)

Suggerimenti e risoluzione dei problemi

Se il motore o il modulo del suono non funzionano:

- Controlla che le batterie siano nuove e che siano installate correttamente.
- Se ancora non dovesse funzionare, chiama il numero di assistenza ai clienti 1-800-KID-KNEX (USA e Canada soltanto). Vedi il retro della scatola per trovare altri modi di contattare K'NEX Industries, Inc.

Se le carrozze si arrestano durante la discesa:

- Il modello è costruito correttamente?
- Controlla che la carrozza non abbia colpito qualche altra parte K'NEX.
- I pezzi della rotaia sono collegati correttamente?
- La carrozza è collegata alla rotaia correttamente?
- Regola la rotaia per eliminare qualsiasi parte piatta sulla stessa.

(Página 2)

Constrói uma montanha-russa verdadeiramente funcional que se eleva a uma altura superior a 1,3 m, juntamente com 10,06 m de pista retorcida e sinuosa. O elevador de corrente motorizada leva as carruagens até ao topo. Seguidamente, observa como as carruagens se deslocam a grande velocidade até à base emitindo os autênticos sons e gritos de uma montanha-russa!

(Página 3)

Coisas importantes para os Pais e os Miúdos

Mantenha estas instruções num local de fácil acesso, pois contêm informações importantes de segurança.

Lê as instruções e advertências antes de começares a construir e a operar o modelo.

AVISO: PERIGO DE SUFOCAÇÃO - Peças pequenas. Não se destina a crianças com menos de 3 anos de idade.

AVISO: Isto é uma classe 1 produto LED.

CUIDADO: Mantém o cabelo, os dedos, a cara e a roupa afastados de todas as peças móveis.

CUIDADO: O cabelo da criança pode ficar emaranhado se entrar em contacto com as peças móveis do brinquedo. É necessária a vigilância de adultos.

CUIDADO: Não use o módulo de som próximo dos ouvidos! O uso incorrecto pode causar danos na audição.

- Compartilhe da experiência K'NEX com os miúdos e faça com que o processo de construção com K'NEX se torne numa aventura entre família.
- Não te precipites para assim poderes desfrutar do processo de construção. Não o faças à pressa!
- Recomenda-se a ajuda de um adulto.
- Tenta fazer com que o teu modelo esteja virado exactamente na mesma direcção indicada nas instruções.
- Tanto o produto como as respectivas cores podem variar.

Informações sobre as pilhas

Cuidado:

- Como acontece com toda as pilhas pequenas, as pilhas usadas neste brinquedo devem ser mantidas fora do alcance de crianças pequenas, que estejam ainda em idade de pôr objectos na boca. No caso destas pilhas terem sido engolidas, consulte imediatamente um médico.
- Certifique-se de que introduz as pilhas correctamente e siga sempre as instruções do fabricante da bateria e do brinquedo.
- Não combine pilhas usadas com pilhas novas, pilhas alcalinas, padrão (carbono-zinco) ou pilhas recarregáveis (níquel-cádmio). Deverão ser usadas apenas pilhas do mesmo tipo ou equivalentes ao tipo recomendado.
- Retire sempre as pilhas fracas ou gastas do produto; não provoque um curto-circuito nos terminais de alimentação.
- Introduza as pilhas com a polaridade correcta (+/-), conforme se mostra.

Conselhos importantes

- Recomenda se o uso de pilhas alcalinas.
- Não se recomenda o uso de pilhas recarregáveis.
- Retire as pilhas recarregáveis do brinquedo antes de as carregar; estas pilhas devem ser recarregadas apenas sob vigilância de adultos.
- As pilhas não recarregáveis não devem ser carregadas.
- Mantenha os componentes livres de poeiras; não mergulhe em água nem use água.

- Não elimine as pilhas queimando-as; estas podem apresentar fugas ou explodir causando lesões.
- Retire todas as pilhas do brinquedo se não tencionar usá-lo durante um longo período de tempo.
- Não coloque varetas de tamanho inferior a 5,1 cm (2 pol.) em nenhuma abertura do motor; as varetas causarão danos no motor e não podem ser removidas.

Como inserir e remover as pilhas

Motor:

- Use uma pequena chave de parafusos de cabeça Phillips para soltar o parafuso e retirar a porta do compartimento da pilha. Introduza 2 pilhas de célula tipo relógio novas LR6 em cada divisória, posicionadas com a polaridade correcta (+/-).

Módulo de Som:

- Use uma pequena chave de parafusos de cabeça Phillips para soltar o parafuso e retirar a porta do compartimento da pilha. Introduza 3 pilhas de célula tipo relógio novas LR03 em cada divisória, posicionadas com a polaridade correcta (+/-).

(Página 4)

Pontos básicos para a construção K'NEX

"Olá! Eu sou o teu companheiro que te vai ajudar a montar o teu K'NEX. Quando você me vê nas instruções, você querará pagar atenção próxima aos detalhes terá que sinalar."

Estás pronto? Começa pois a construir

Para começar o teu modelo, procura o 1 e segue os números. Cada peça tem a sua própria forma definida e cor. Basta simplesmente olhares para a ilustração, procurar as peças do teu jogo correspondentes às que estás a ver e, em seguida, conectar umas nas outras. Enquanto estás a montar as peças, tenta manter o teu modelo na mesma direcção, conforme mostrado na ilustração, para assim ligares as peças correctamente.

Continuando

As cores desbotadas indicam que esta secção já está montada. Passarás então a fazer a conexão da nova secção no local indicado pelas setas. Esta peça terá uma cor viva.

Conectores

É muito importante que posicione os conectores azuis e cor de prateados numa direcção específica. Presta muita atenção às instruções e coloca estes conectores horizontal ou verticalmente, exactamente conforme se mostra nas ilustrações. Junta as partes simultaneamente e com firmeza até ouvires um "estalido".

Espaçadores

Existirão certos pontos no teu modelo que necessitam a colocação de espaçadores azuis e prateados. Assegura-te que os contas cuidadosamente.

(Página 73)

Sugestões e Resolução de Problemas

Se o Motor ou o Módulo de Som não funcionar:

- Verifica se as pilhas são novas e se estão instaladas correctamente.
- Caso continuem sem funcionar, contacta a Linha Directa de Atendimento ao Consumidor através do número 1-800-KID-KNEX (apenas nos EUA e no Canadá). Consulta a contra capa para mais informações sobre como contactares a K'NEX Industries, Inc.

Se as Carruagens ficarem encravadas na descida:

- O modelo foi construído correctamente?
- Assegura-te de que a Carruagem não está a chocar contra outras peças K'NEX.
- As peças da Pista estão ligadas correctamente?
- A Carruagem está presa à Pista correctamente?
- Ajusta a Pista para eliminares qualquer ponto plano na Pista.



VERTICAL VENGEANCE™ COASTER

Product and colors may vary.
Models can be built one at a time.
Le produit et les couleurs peuvent varier.
La plupart des modèles ne peuvent être
construits que un à un.
El producto y los colores podrán variar.
La mayoría de los modelos se puede construir
uno a la vez.

Conforms to the Requirements of ASTM
Standard Consumer Safety Specification on
Toy Safety, F963-03.
Conforme aux spécifications de sécurité du
consommateur sur la sécurité des jouets de
la norme ASTM F963-03.
Cumple con los requisitos de la Norma F963-03,
[Especificación para consumidores sobre la
seguridad de juguetes], de la ASTM.

Manufactured under U.S. Patents
Fabriqué sous brevets américains 5,061,219;
5,137,486; 5,199,919; 5,346,420; 5,350,331;
5,368,514; 5,421,762; 5,423,707; 5,427,559;
D383,509; D388,475; D389,203; D391,843;
D392,555; D403,722; 5,913,706; 6,089,941.
Other U.S. and foreign patents pending.
Autres brevets américains
et étrangers en instance.

©2006 K'NEX Industries, Inc.
P.O. Box 700
Hatfield, PA 19440-0700



406436.11-V2-05/06



US 1-800-KID-KNEX USA/Canada only (English only)

GB 00800-22427276 UK/Ireland only

**Customer Service outside the USA, CAN, GBR
please contact local distributor.
Distributor information can be found at:
<http://www.knex.com/contact/international.php>**



**US Consumer Services
K'NEX Industries, Inc.
P.O. Box 700
Hatfield, PA 19440-0700**



email@knex.com



**GB K'NEX
Newport Consumer Services
Hasbro UK Ltd., Caswell Way
Newport, Gwent NP9 0YH**

