

K'NEX®

Imagine • Build • Play®

9+

SUPER CYCLONE COASTER™



**2.7ft
.82m**



675pc/pza/pç

51957



EN CONTENTS

K'NEX Building Basics	4
Parts List	5
SUPER CYCLONE COASTER™	6
Track Building Tips	28
Tips & Troubleshooting.	46
Building Idea.	47

Go to **K'NEX.COM**
for instruction updates

Important stuff for Parents & Kids

Keep these instructions in a handy location. They contain important safety information. Read all warnings and instructions before you start to build and operate the model.

⚠ WARNING: CHOKING HAZARD - Small parts. Not for children under 3 years.

CAUTION: Keep hands, face, hair and clothing away from all moving parts.

CAUTION: Be careful not to tip the model over. Model should be placed on a flat and hard surface.

- Share the K'NEX experience with your child and make building with K'NEX a family fun adventure.
- Take your time to enjoy the building process. Don't rush!
- While you're building make sure you face your model in the same direction as the pictures show in the instructions.
- Product and colors may vary.

ES CONTENIDOS

Esenciales de construcción K'NEX.	4
Lista de Piezas	5
SUPER CYCLONE COASTER™	6
Consejos para armar la pista	28
Consejos y solución de problemas	46
Ideas de armado.	47

Vaya a **K'NEX.COM** para
actualizaciones de instrucción

Cosas importantes para padres y niños

Guarde estas instrucciones en un lugar accesible. Contienen información importante de seguridad.

Lea todas las advertencias e instrucciones antes de comenzar a armar y operar el modelo.

⚠ ADVERTENCIA: RIESGO DE ASFIXIA, piezas pequeñas. Diseñado para niños mayores de 3 años de edad.

PRECAUCIÓN: Mantenga las manos, la cara, el pelo y la ropa lejos de las partes que se muevan.

PRECAUCIÓN: Tenga cuidado de no volcar el modelo. El modelo se debe colocar en una superficie plana y dura.

- Comparta la experiencia K'NEX con su hijo y haga de la construcción con K'NEX una divertida aventura familiar.
- Tome su tiempo y disfrute el proceso de construcción. ¡No se apresure!
- Mientras construye, asegúrese de colocar su modelo en la misma dirección que en las imágenes que se muestran en las instrucciones.
- El producto y los colores pueden variar.

PT ÍNDICES

Peças básicas do K'NEX.	4
Lista de Peças	5
SUPER CYCLONE COASTER™	6
Dicas para a montagem dos trilhos	28
Dicas e resolução de problemas.	46
Ideias para outras montagens	47

Visite **K'NEX.COM** para
obter atualizações das instruções

Informações importantes para pais e filhos

Guarde este folheto em um lugar seguro, pois ele contém informações importantes de segurança.

Leia todas as advertências e instruções antes de começar a construir e operar o modelo.

⚠ ADVERTÊNCIA: PERIGO DE ASFIXIA – Peças pequenas. Não se destina a crianças menores de 3 anos.

CUIDADO: Mantenha as mãos, rosto, cabelo e roupas longe das partes em movimento.

CUIDADO: Tenha o cuidado de não derrubar o modelo. O modelo deverá ser montado em uma superfície plana e dura.

- Compartilhe a experiência de construir com K'NEX com os seus filhos e torne a montagem de modelos K'NEX uma aventura familiar divertida.
- Disfrute do processo de montagem, sem se apressar.
- Enquanto você estiver montando o modelo, fique de frente para o modelo, na mesma direção que as figuras mostradas nas instruções.
- O produto e as cores poderão variar.

Battery Information

CAUTION:

- Be sure to insert the batteries correctly and always follow the toy and battery manufacturers' instructions.
- Do not mix old and new batteries or alkaline, standard (carbon-zinc) or rechargeable (nickel-cadmium) batteries. Only batteries of the same or equivalent type recommended should be used.
- Always remove weak or dead batteries from the product; do not short-circuit supply terminals.
- Insert batteries with correct polarity (+/-) as shown.

Important tips

- Alkaline batteries AA (LR6) are recommended.
- Rechargeable batteries are not recommended.
- Remove rechargeable batteries from toy before charging; they must be charged only under adult supervision.
- Non-rechargeable batteries must not be recharged.
- Keep components free of dust; do not immerse or use in water.
- Do not dispose of batteries in a fire; they could leak or explode and cause injury.

- Remove all batteries if the toy will not be used for a long period of time.
- Do not put rods smaller than 2 inches in any openings of the motor; they will damage the motor and cannot be removed.
- Help the environment by disposing of your product and packaging responsibly. The wheelie bin symbol indicates that the product and batteries must not be disposed of in the domestic waste as they contain substances which can be damaging to the environment and health. Please use designated collection points or recycling facilities when disposing of the item or batteries.

Información Acerca de las Pilas

PRECAUCIÓN:

- Asegúrese de insertar las pilas correctamente y de siempre seguir las instrucciones del fabricante del juguete y de las pilas.
- No mezcle pilas viejas con nuevas, ni pilas alcalinas, estándar (carbón-zinc) o recargables (níquel-cadmio). Se debe usar solamente pilas del mismo tipo, o las que se recomienden como equivalentes.
- Siempre retire las pilas débiles o gastadas del producto; no forme cortocircuito en los puntos de intercambio.
- Inserte las pilas de acuerdo con los esquemas de polaridad (+/-).

Consejos importantes

- Se recomiendan las pilas alcalinas.
- No se recomiendan las pilas recargables.
- Retire las pilas recargables del juguete antes de cargarlas; éstas deben ser cargadas solamente bajo la supervisión de un adulto.
- No se debe recargar las pilas que no son recargables.
- Mantenga los componentes sin polvo; no sumerja ni use en agua.
- No deseche las pilas en el fuego ya que pueden tener fugas, explotar y causar lesiones personales.

- Retire todas las pilas si el juguete no se usará por mucho tiempo.
- No meta las varillas pequeñas en los orificios del motor ya que dañarían el motor y no se podrían sacar.
- Proteja el medio ambiente desechando su producto y el embalaje de una manera responsable. El símbolo del recipiente con ruedas indica que el producto y las pilas no deben tirarse en la basura doméstica, ya que contienen sustancias que pueden dañar el medio ambiente y la salud. Por favor acuda a los lugares de recolección designados o a instalaciones de reciclaje para desechar el artículo o las pilas.

Informações Sobre as Pilhas

CUIDADO:

- Certifique-se de que as pilhas foram colocadas corretamente e siga sempre as instruções do fabricante da bateria e do brinquedo.
- Não combine pilhas usadas com pilhas novas, pilhas alcalinas, padrão (carbono-zinco) ou pilhas recarregáveis (níquel-cádmio). Deverão ser usadas apenas pilhas do mesmo tipo ou equivalentes ao tipo recomendado.
- Retire sempre as pilhas fracas ou gastas do produto; não provoque um curto-circuito nos terminais de alimentação.
- Introduza as pilhas com a polaridade correta (+/-), conforme se mostra.

Conselhos importantes

- Recomenda-se o uso de pilhas alcalinas.
- Não se recomenda o uso de pilhas recarregáveis.
- Retire as pilhas recarregáveis do brinquedo antes de as carregar; estas pilhas devem ser recarregadas apenas sob vigilância de adultos.
- As pilhas não recarregáveis não devem ser carregadas.
- Mantenha os componentes livres de poeiras; não mergulhe em água nem use água.
- Não elimine as pilhas queimando-as; estas podem apresentar fugas ou explodir causando lesões.
- Retire todas as pilhas do brinquedo se não tencionar usá-lo durante um longo período de tempo.

- Não coloque varetas de tamanho inferior a 5,1 cm (2 pol.) em nenhuma abertura do motor; as varetas causarão danos no motor e não podem ser removidas.
- Ajude o ambiente eliminando o seu produto e a embalagem vazia responsabilmente. A imagem do contentor do lixo com rodinhas indica que o produto e as pilhas não devem ser eliminados juntamente com os resíduos domésticos pois contêm substâncias que podem provocar efeitos nocivos no ambiente e na saúde. Por favor use os pontos de recolha designados ou as instalações de reciclagem quando necessitar de eliminar o produto ou as pilhas.

How to insert and remove batteries

Use a small Phillips head screwdriver to loosen the screw. Insert 2 new AA batteries (LR6) into the compartment with the correct polarity (+/-) as shown here.

Cómo colocar y retirar las baterías

Utilice un destornillador Phillips pequeño para aflojar el tornillo. Inserte 2 baterías AA nuevas (LR6) en el compartimiento con la polaridad correcta (+/-), como se muestra aquí.

Como colocar e remover as pilhas

Use uma pequena chave de fenda para desparafusar o parafuso. Coloque 2 pilhas pequenas, tamanho AA novas (LR6) no compartimento com a polaridade correta (+/-), conforme mostrado aqui.





Building Basics

Básicos de Construcción

Princípios do edifício

Start Building

To begin your model, find the **1** and follow the numbers. Each piece has its own shape and color. Just look at the pictures, find the pieces in your set that match and then connect them together. Try to face your model in the same direction as the instructions while you build. The arrows show you where the parts connect, but not all connections points have arrows. Faded colors show you this section is already built.

Para comenzar a construir

Para comenzar el modelo, encuentre el número del paso **1** y siga los números. Cada pieza tiene su propia forma y color. Observe las imágenes, encuentre las piezas que sean iguales a las que se muestran y conéctelas. Colocar el modelo en la misma dirección que se encuentra en las instrucciones le facilitará la construcción. Las flechas muestran en dónde se conectan las piezas, pero no todos los puntos de conexión tienen flechas. Las partes de color tenue son las que ya armó.

Comece a montar

Para começar a montar o modelo, encontre o número do passo **1** e siga os números. Cada peça tem a sua própria forma e cor. Estude as ilustrações, encontre as peças que coincidem com o que você estiver vendo e conecte-as. Fique de frente para o modelo, na mesma direção que as figuras mostradas nas instruções. As setas mostram onde as peças se conectam, mas nem todos os pontos de conexão têm setas. As partes com cores desbotadas são as que você já montou.

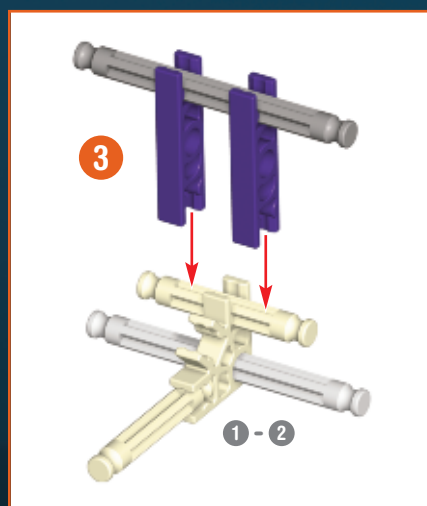
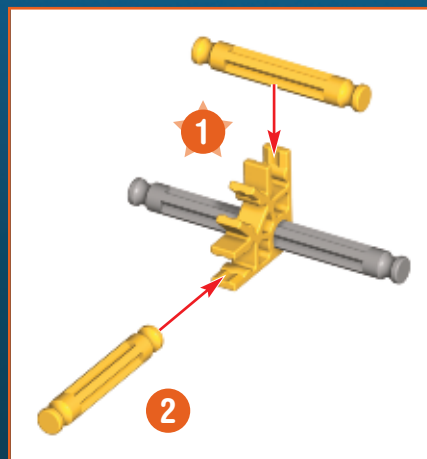

Connectors

There are blue and gray connectors with special long slots. They slide together as you see in the pictures. Push these parts together until you hear a "click."

Conectores

Puede unir estos conectores especiales deslizando los. Presione con fuerza hasta que oiga un "clic" Preste especial atención a las instrucciones y colóquelos de forma horizontal o vertical, exactamente como se muestra.

Conectores

É muito importante que posicione os conectores azuis e cor de prateados numa direção específica. Preste muita atenção às instruções e coloque estes conectores horizontal ou verticalmente, exatamente conforme se mostra nas ilustrações. Junte as partes simultaneamente e com firmeza até ouvir um "estalido".

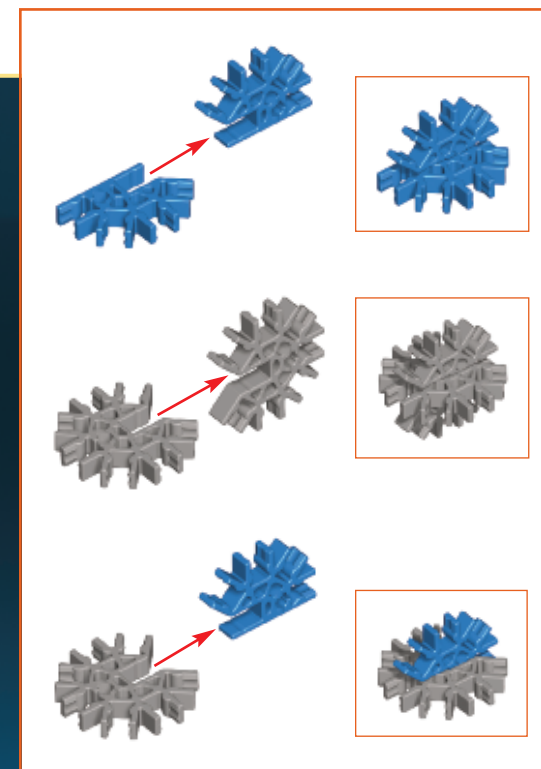

Chain

Be sure to attach all the chain links in the same direction.



Cadena

Asegúrate de fijar todos los elementos de la cadena en la misma dirección.

Corrente

Assegure-se que todos os elos estão presos seguindo a mesma direção.

Spacers

There are places in your model where you need to add blue and silver spacers. Be sure to use the right color and count them carefully.

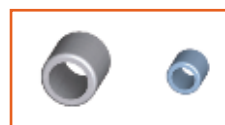

Separadores

Hay sitios en el modelo en los que necesita utilizar separadores. Asegúrese de usar el número correcto de separadores que se muestra en las instrucciones.

Separadores

Há lugares no modelo onde você precisará usar separadores. Use o número de espaçadores corretos exibidos nas instruções.

Parts List

Before you start building, be sure to compare the parts in your set with the parts list here. If anything is missing, call or write to us using the information on the back cover. We are here to help you!

Lista de Piezas

Antes de comenzar a construir, compare las piezas de su juego con las que se enumeran aquí. Si falta algo, llámenos o escribanos utilizando la información que se encuentra en el reverso. ¡Estamos aquí para ayudarle!

Lista de peças

Antes de começar a montar, compare as partes do seu conjunto com as partes enumeradas aqui. Se houver algo que estiver faltando, ligue ou escreva para nós usando as informações na capa de trás. Estamos aqui para servir e ajudar!

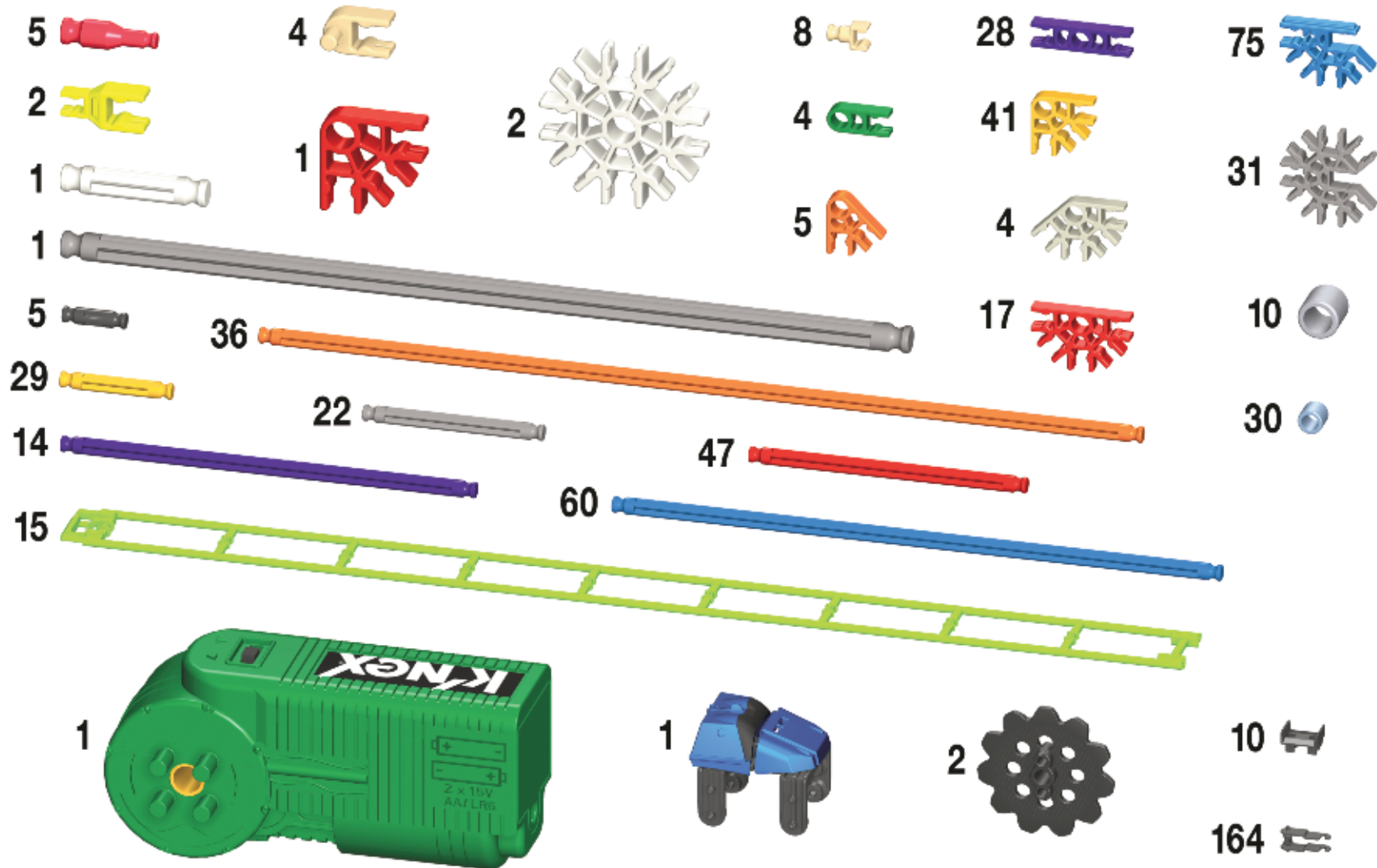

SUPER CYCLONE COASTER™

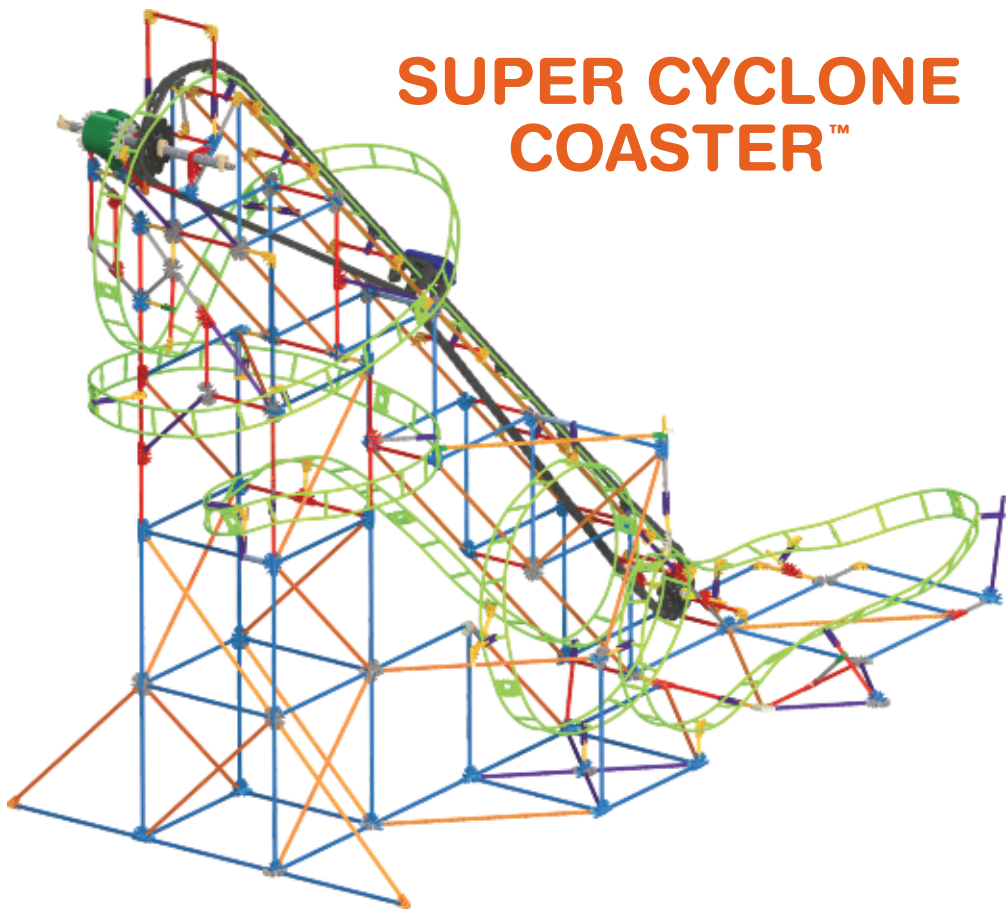

WARNING: CHOKING HAZARD - SMALL PARTS. Not for children under 3 years.

ADVERTENCIA: RIESGO DE ASFIXIA, piezas pequeñas. Diseñado para niños mayores de 3 años de edad.

ADVERTÊNCIA: PERIGO DE ASFIXIA – Peças pequenas. Não se destina a crianças menores de 3 anos.

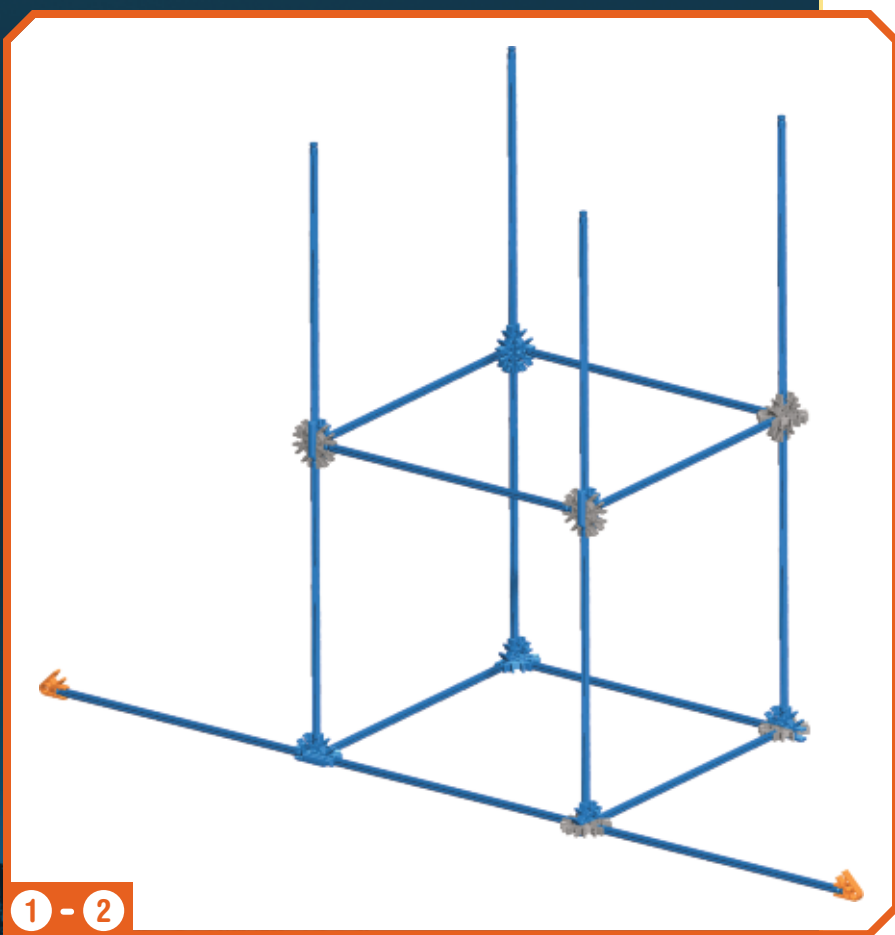

1 - 2

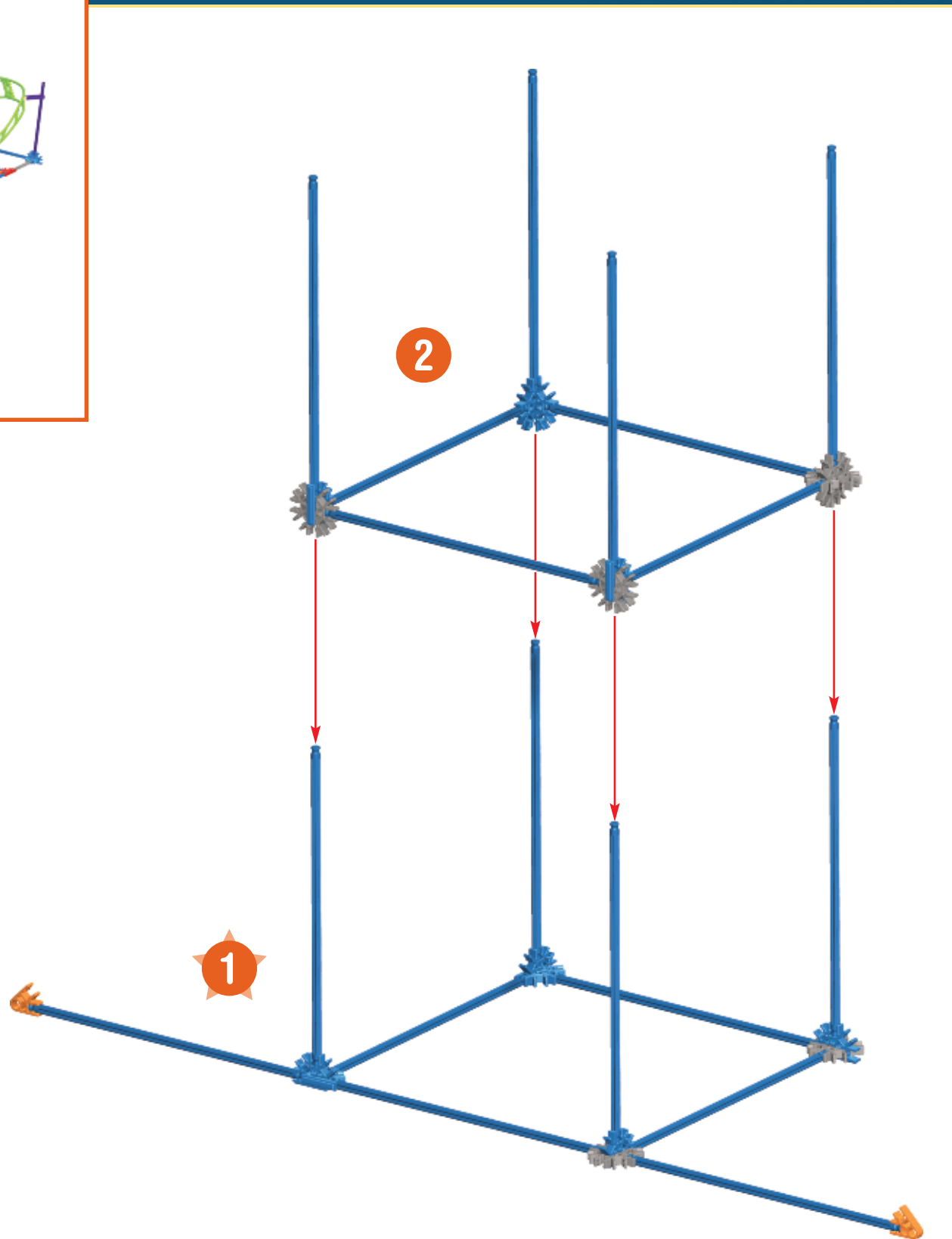

1

2

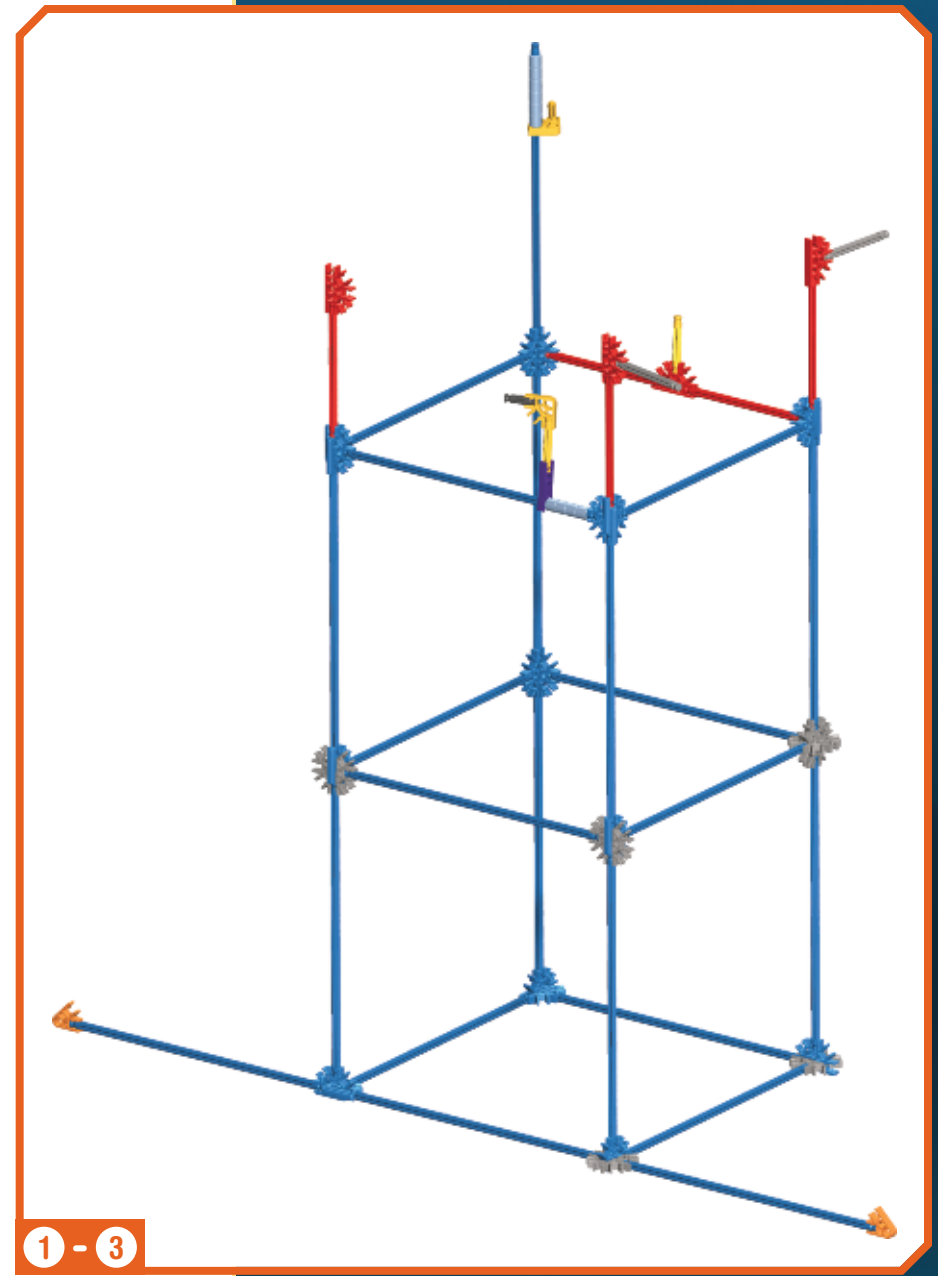
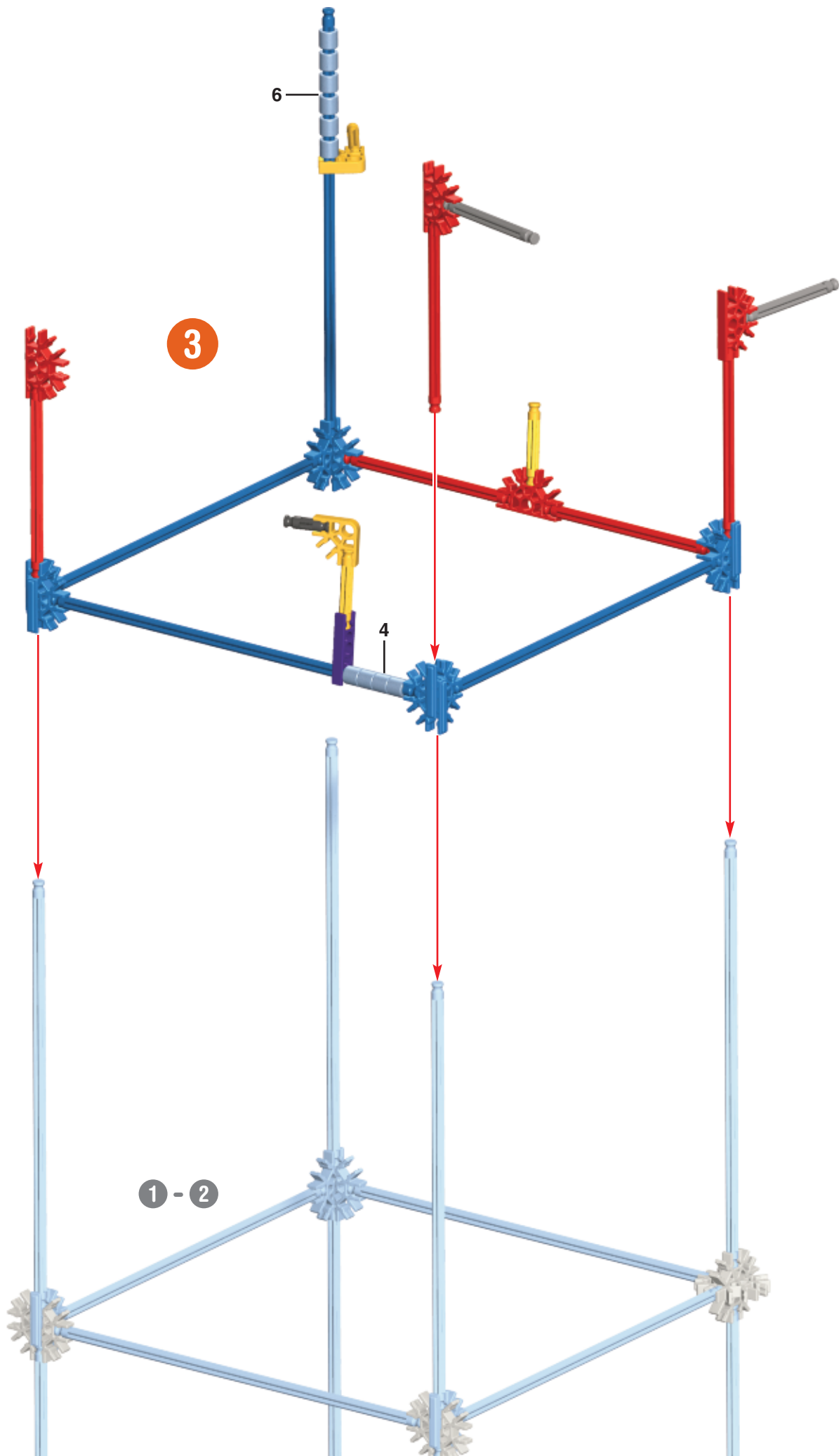

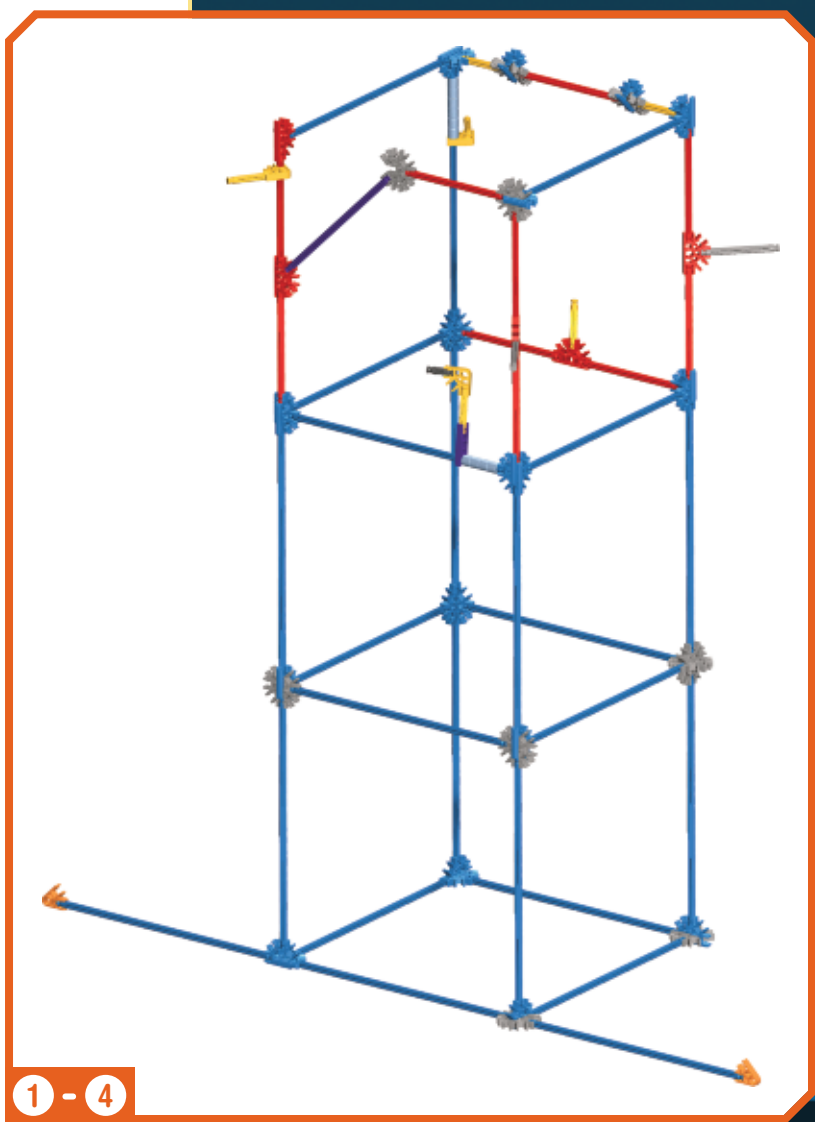
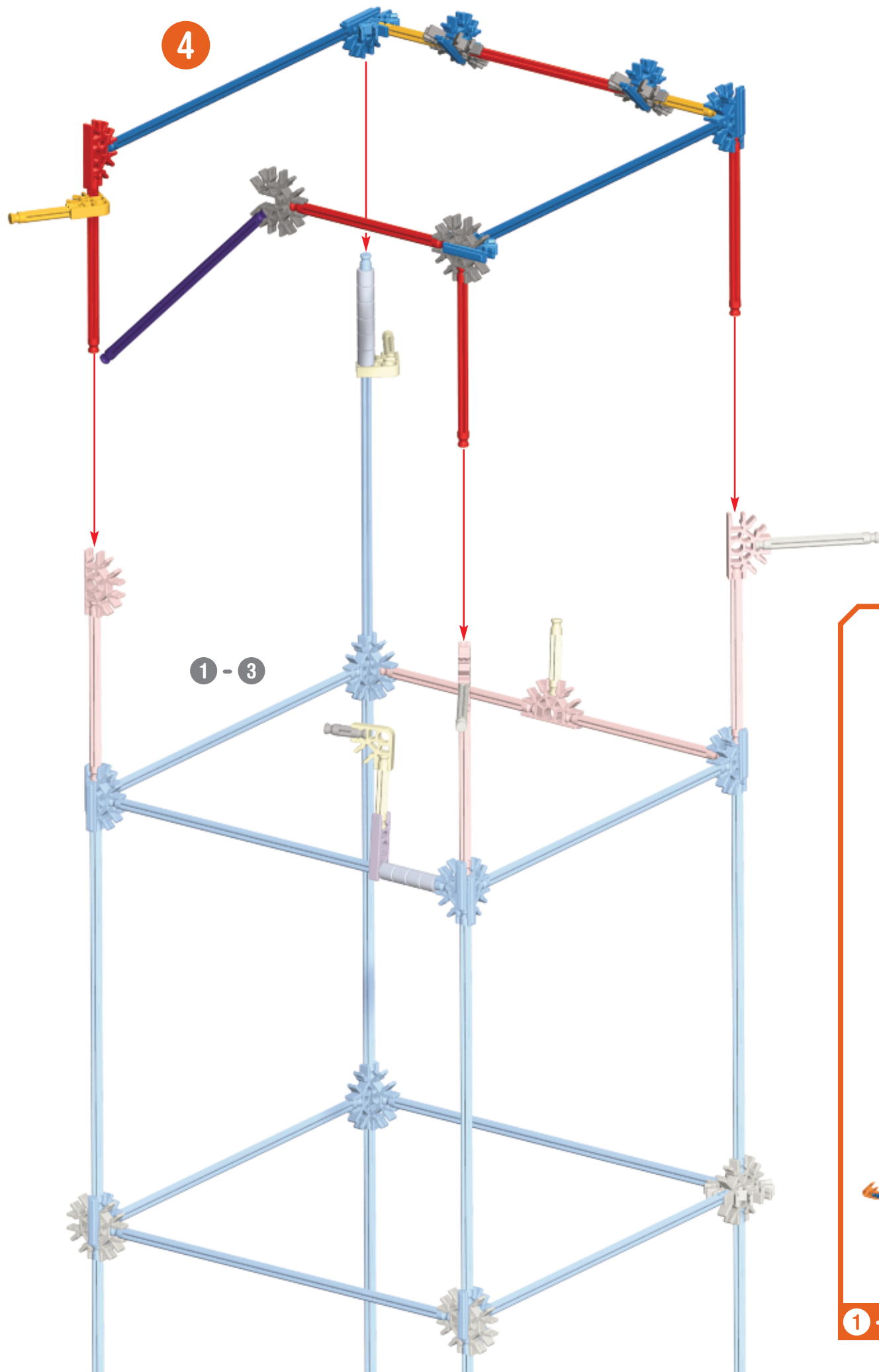

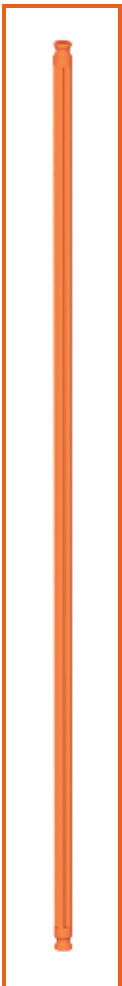

x6

5

1 - 4

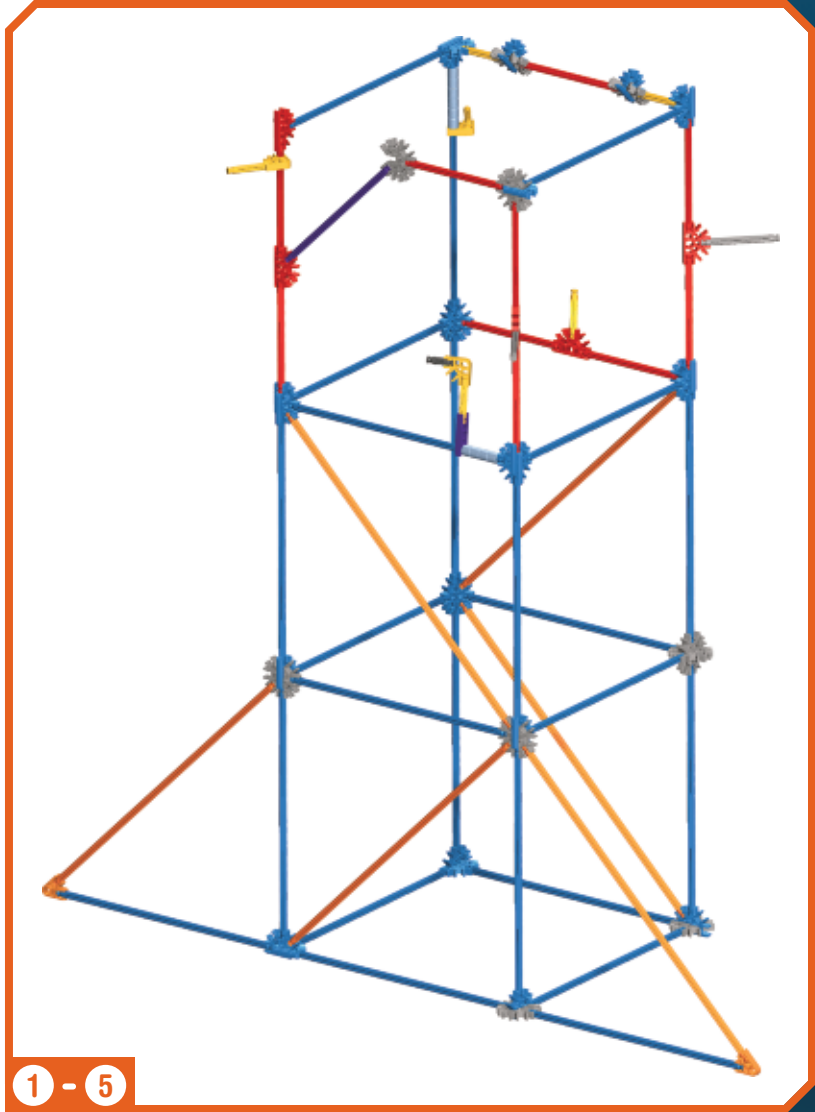
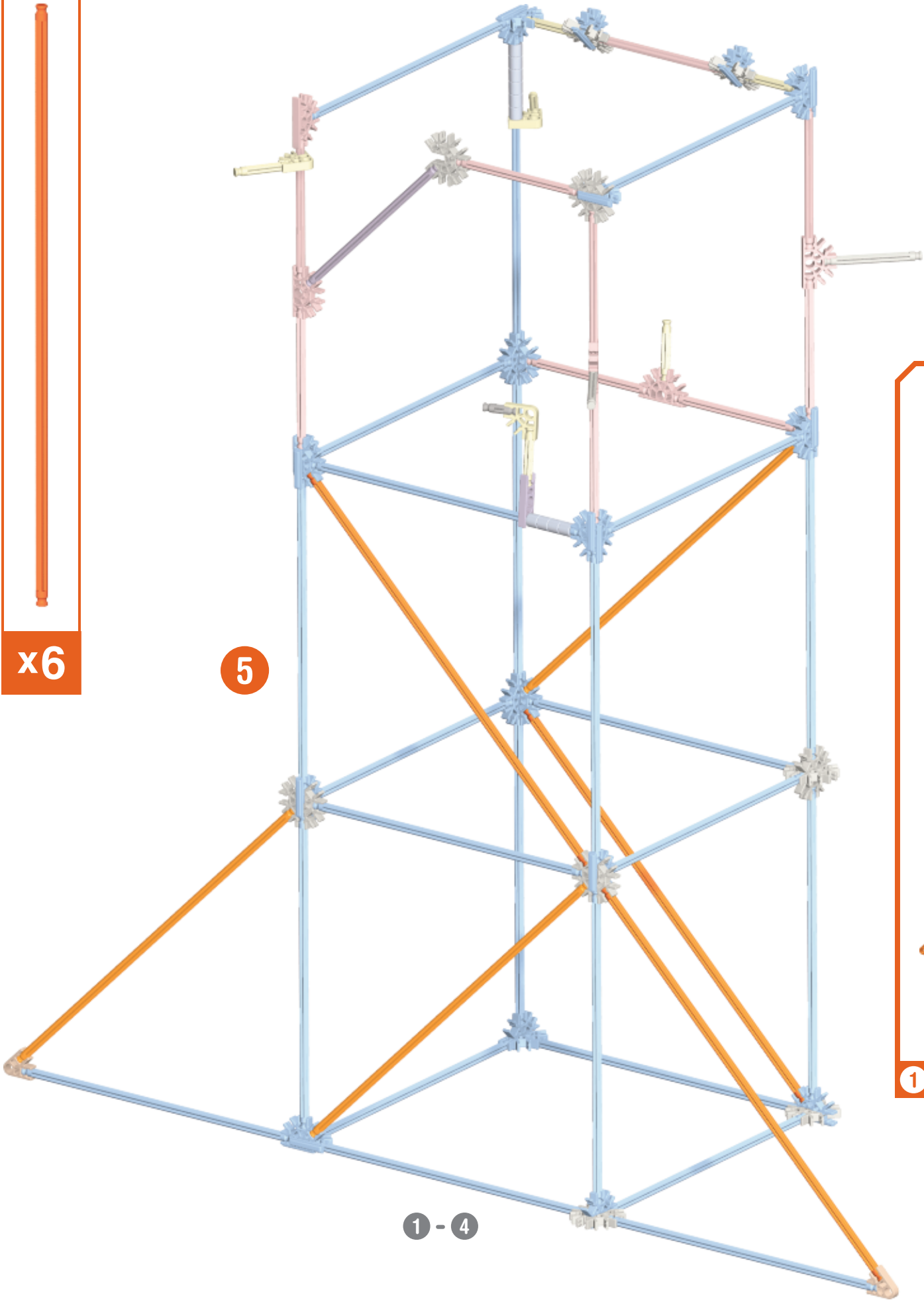

1 - 5



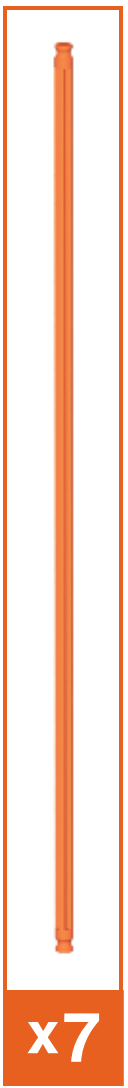

6

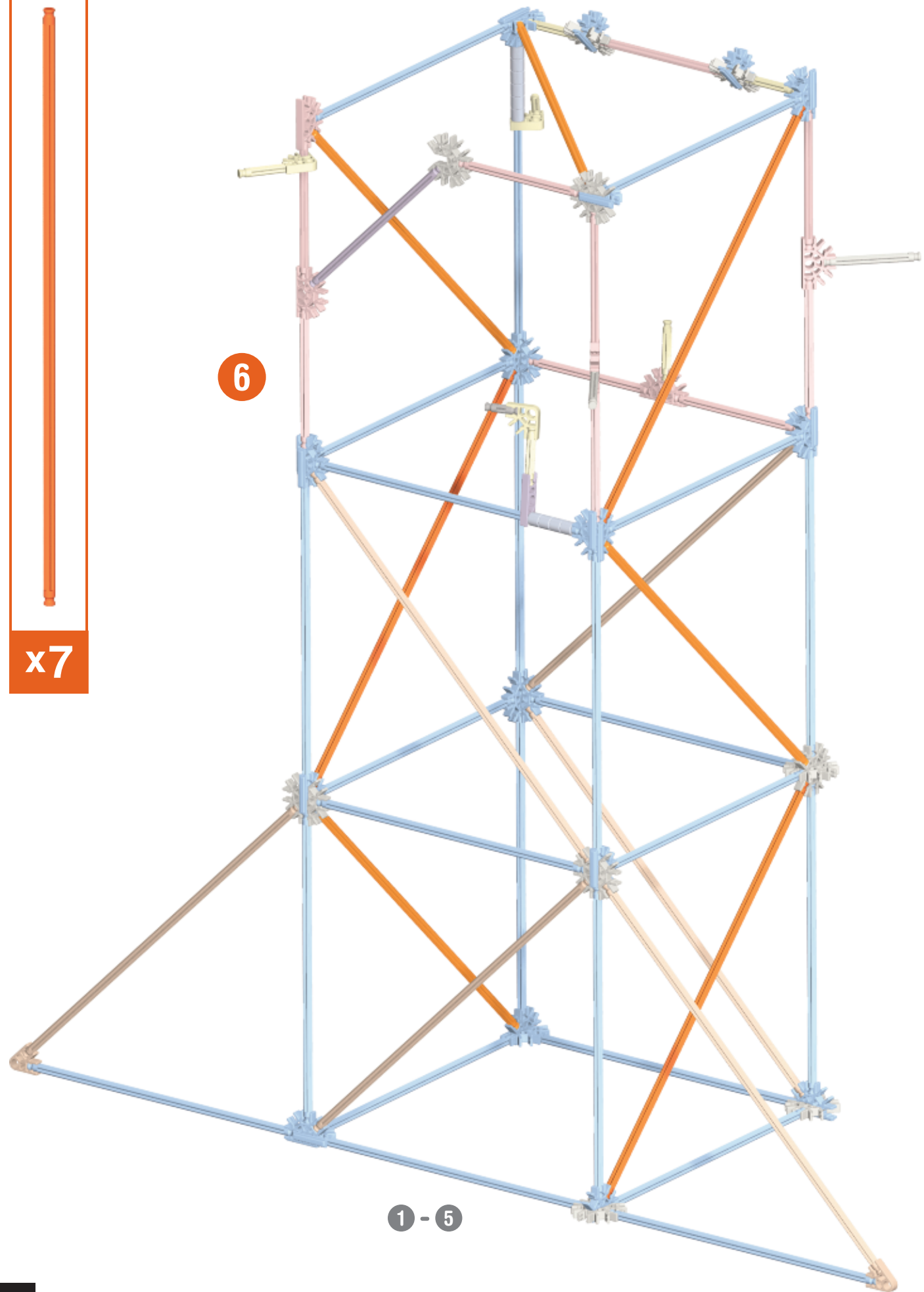

1 - 5

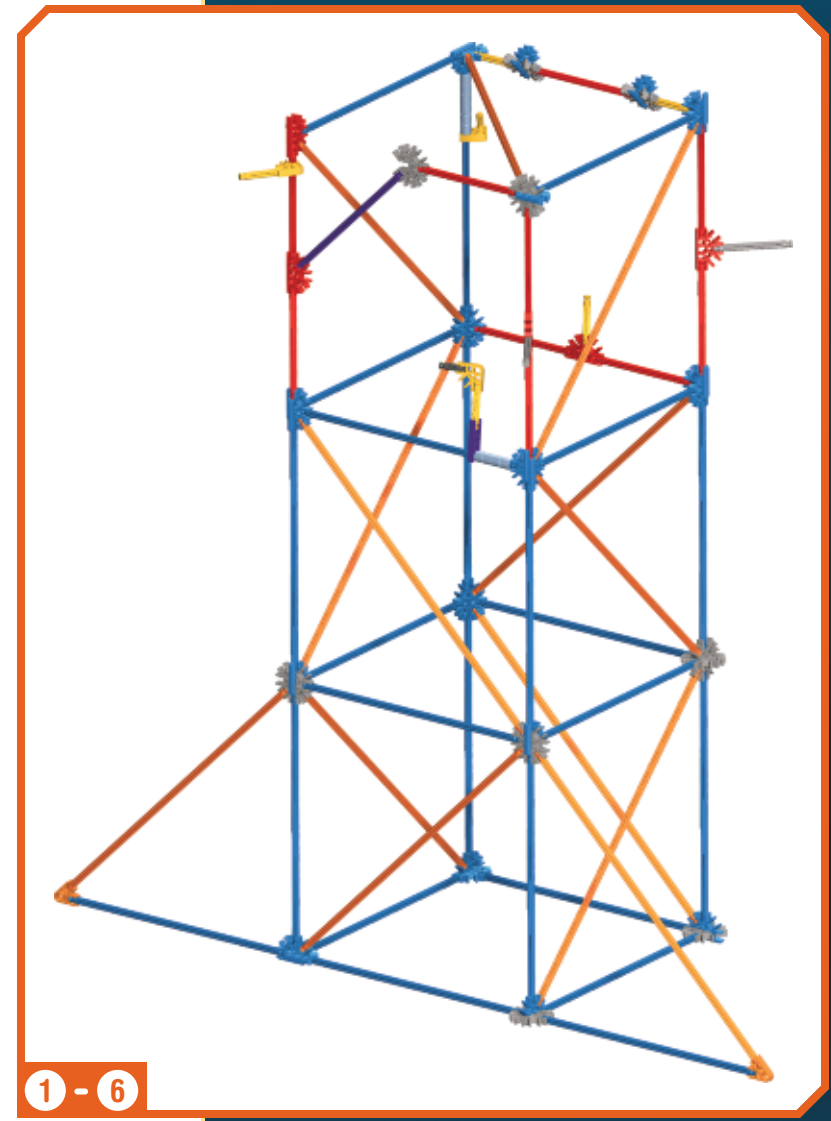

1 - 6

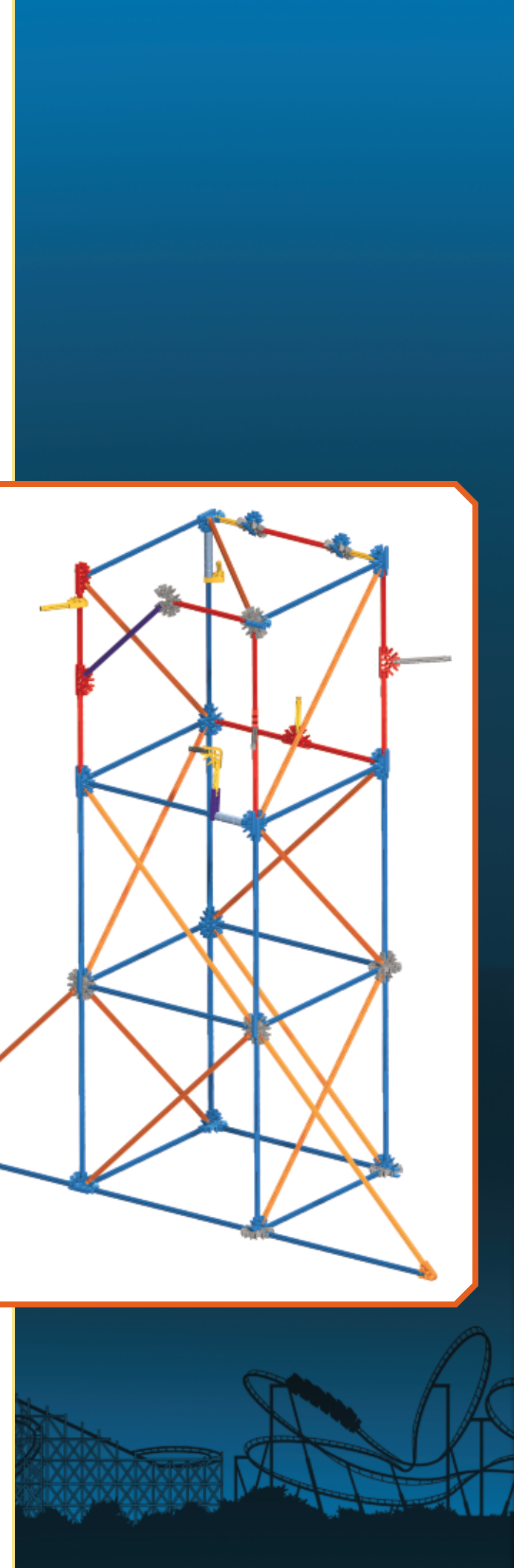

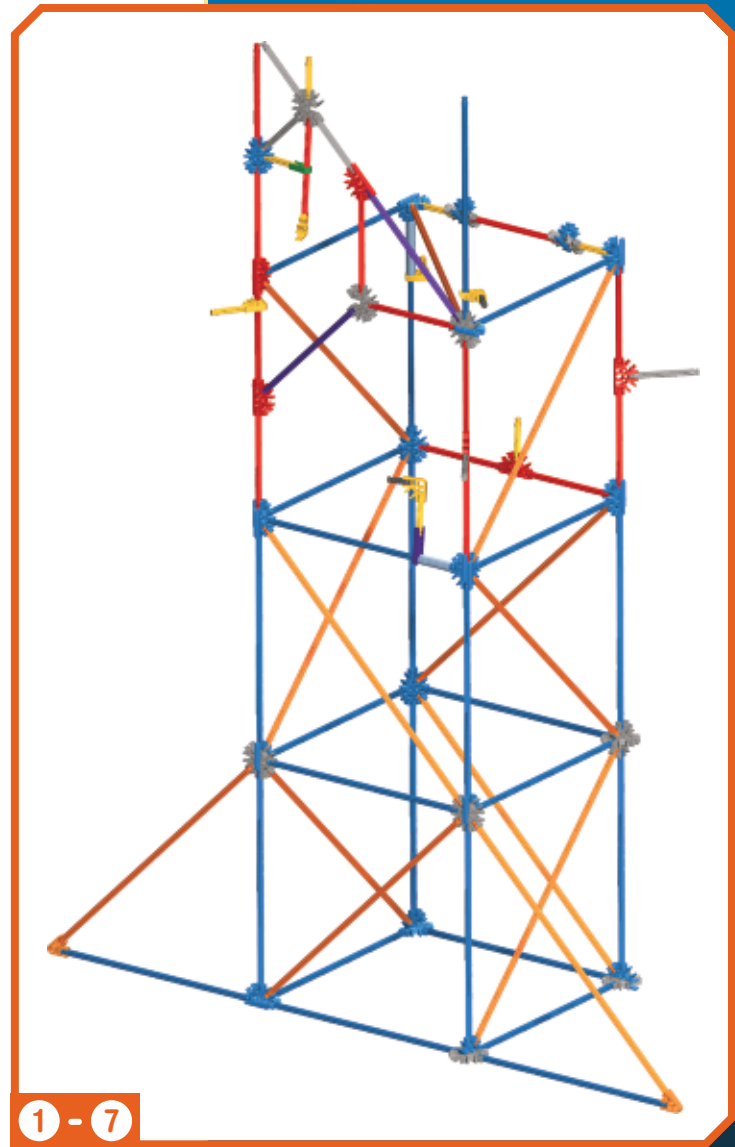
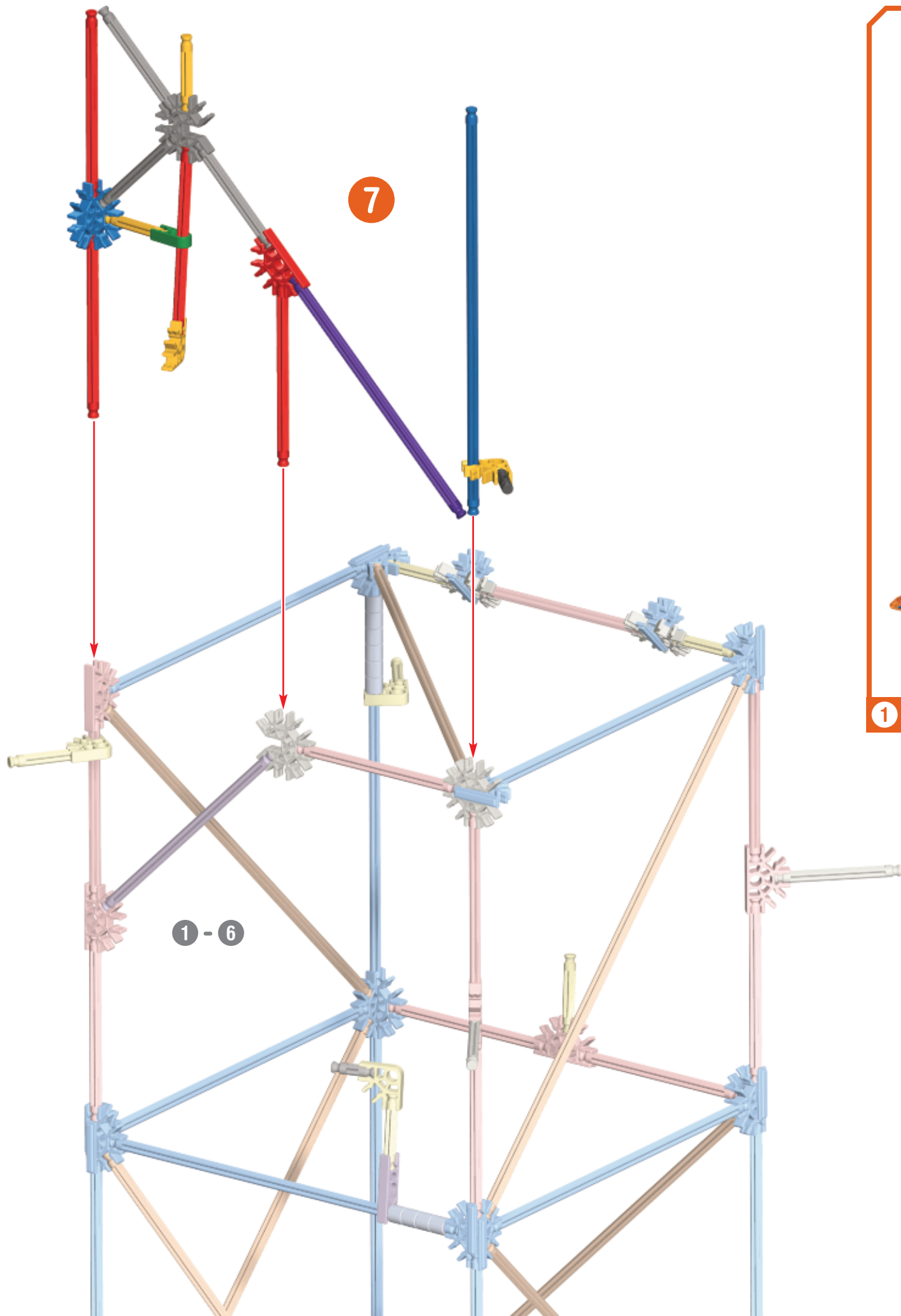

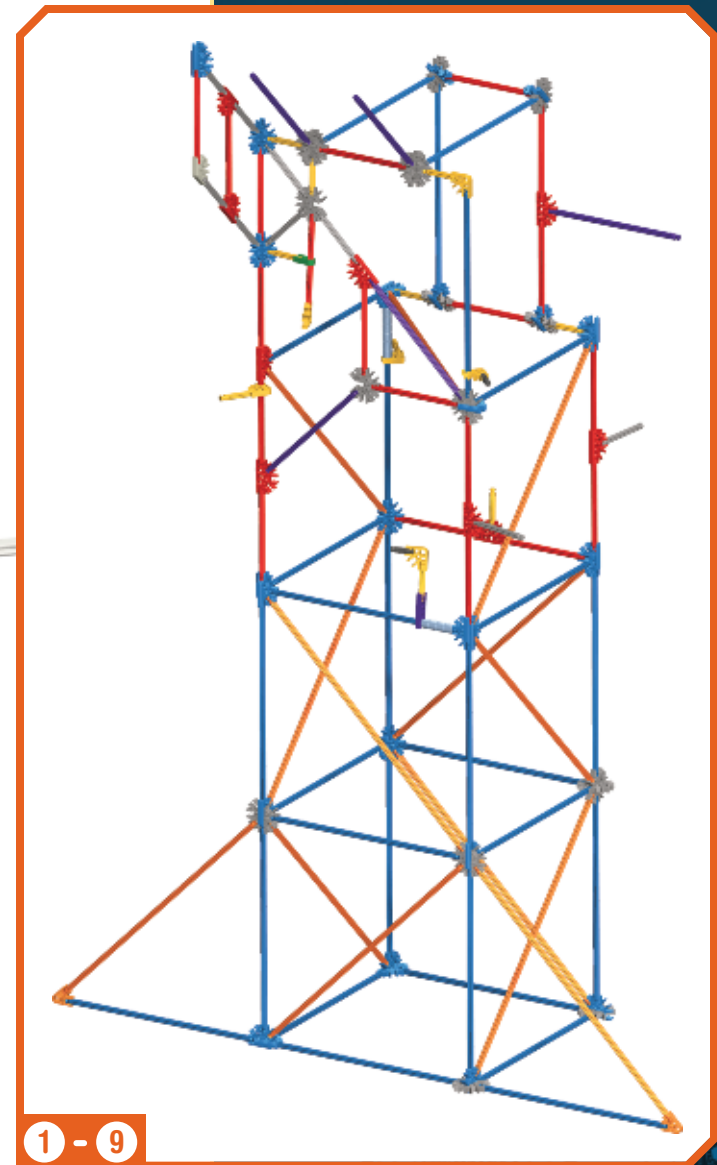
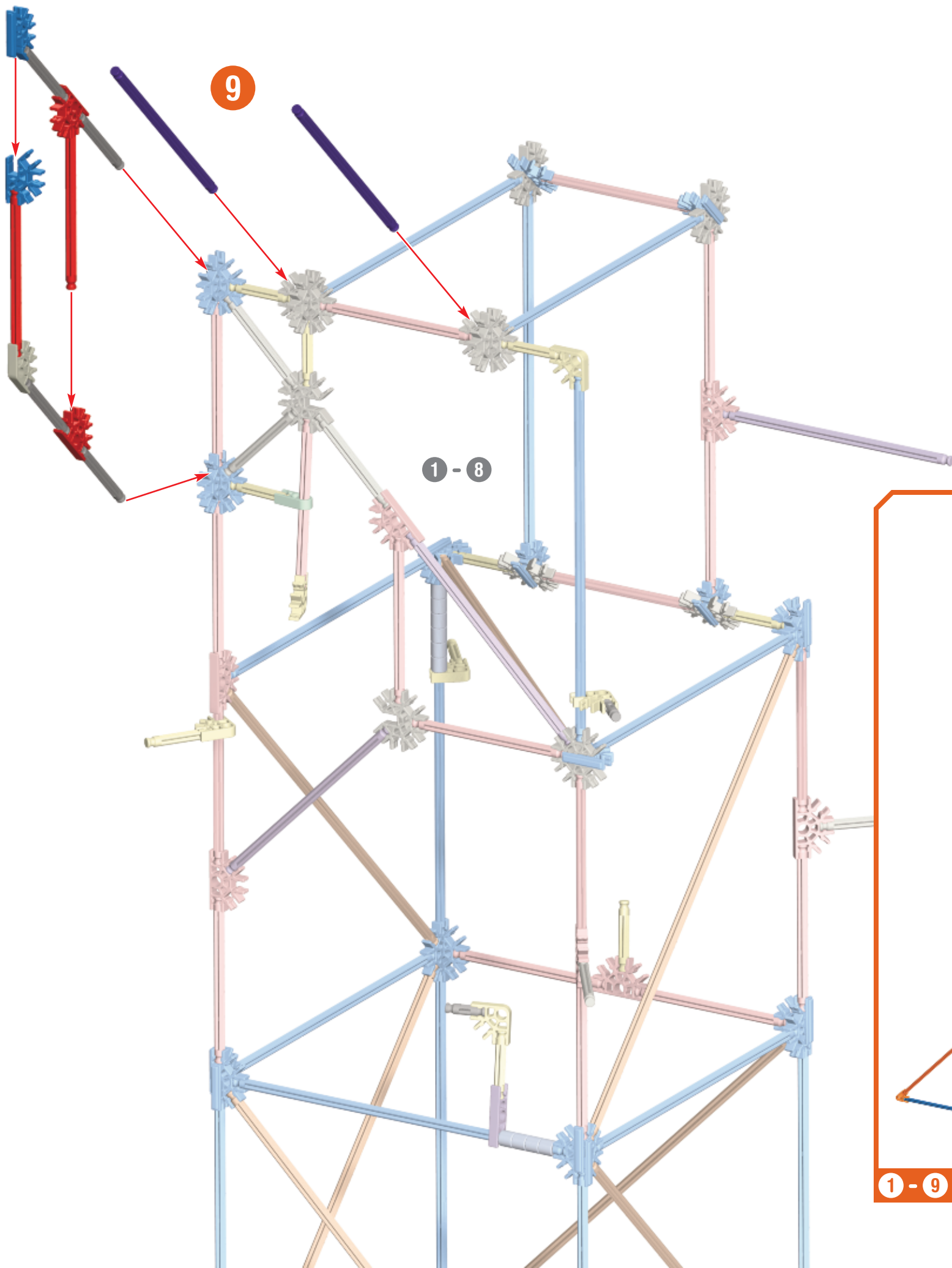

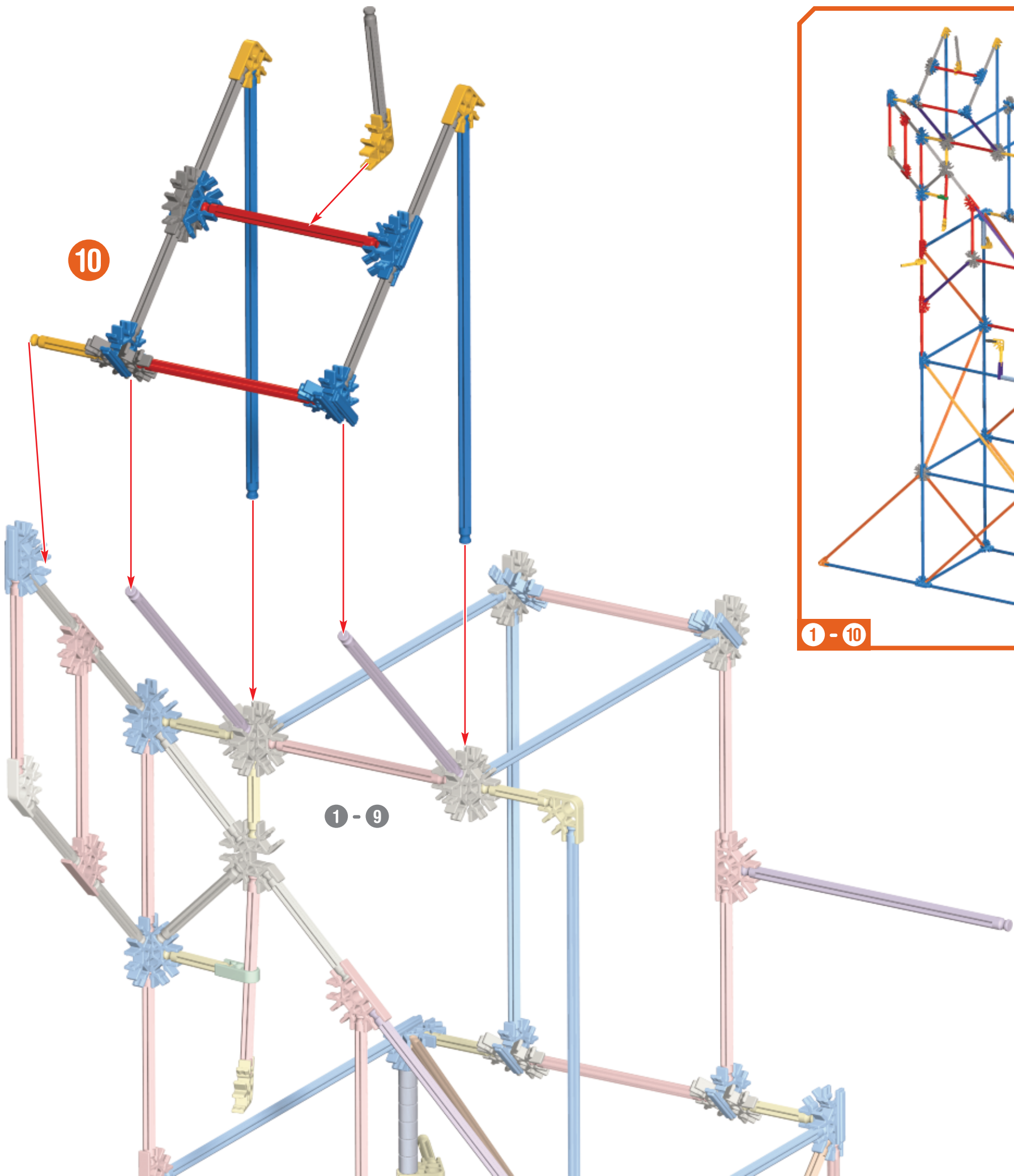

10

1 - 9

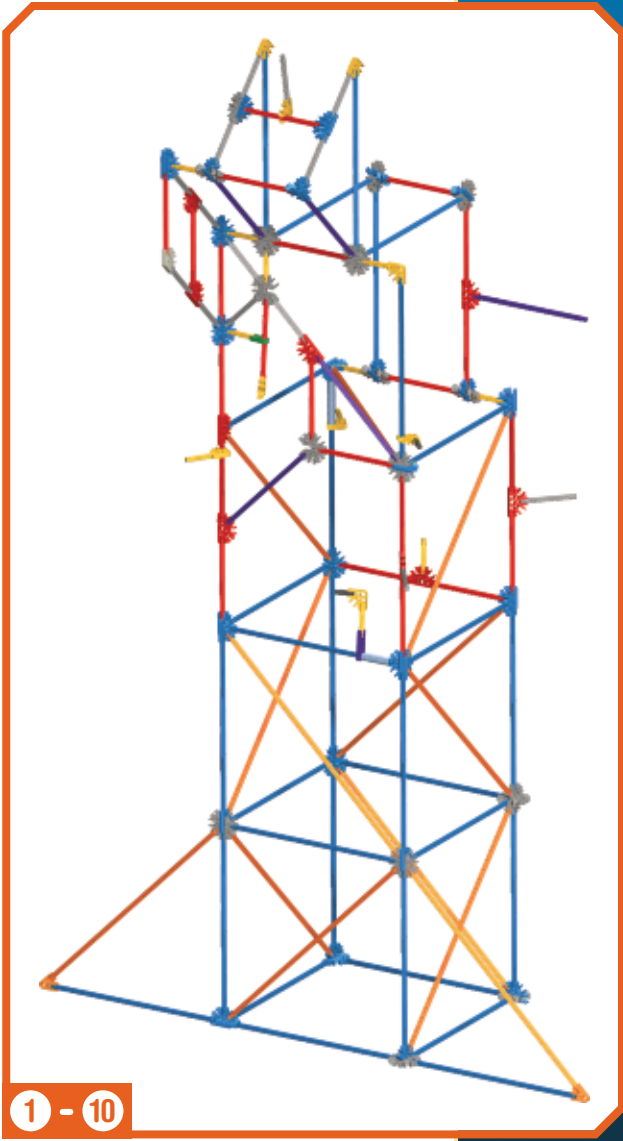

1 - 10

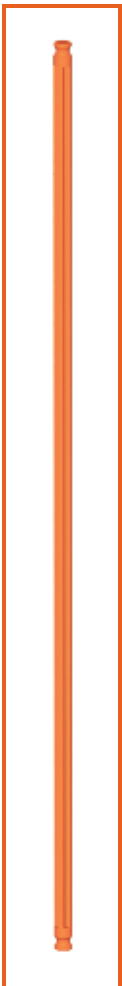

x4

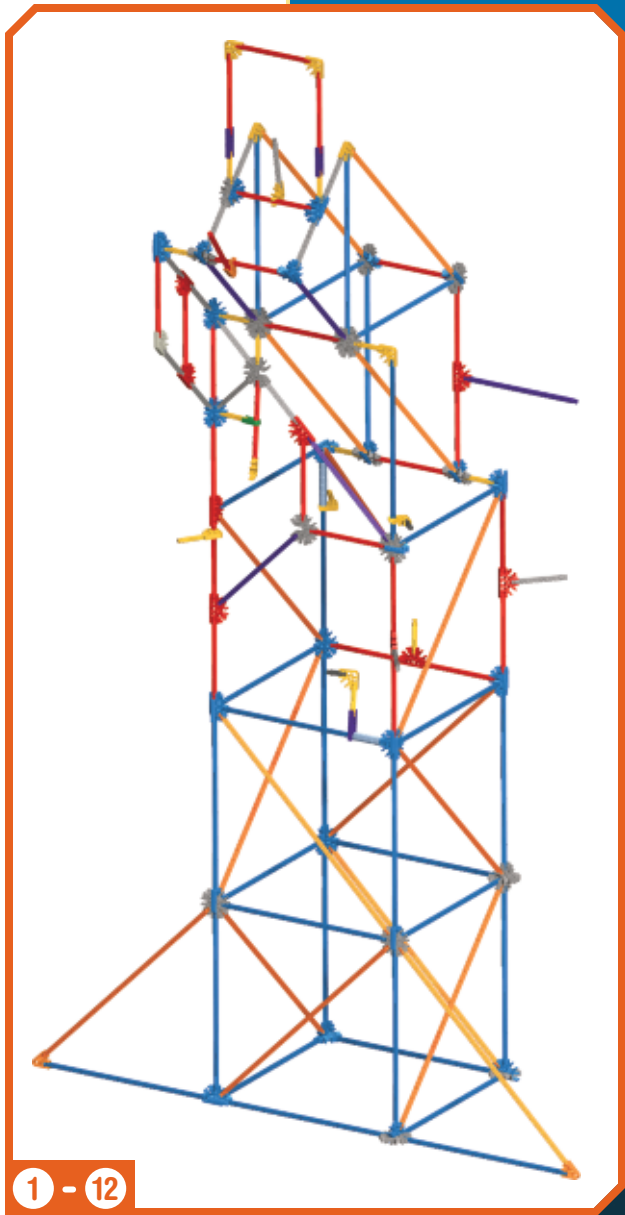
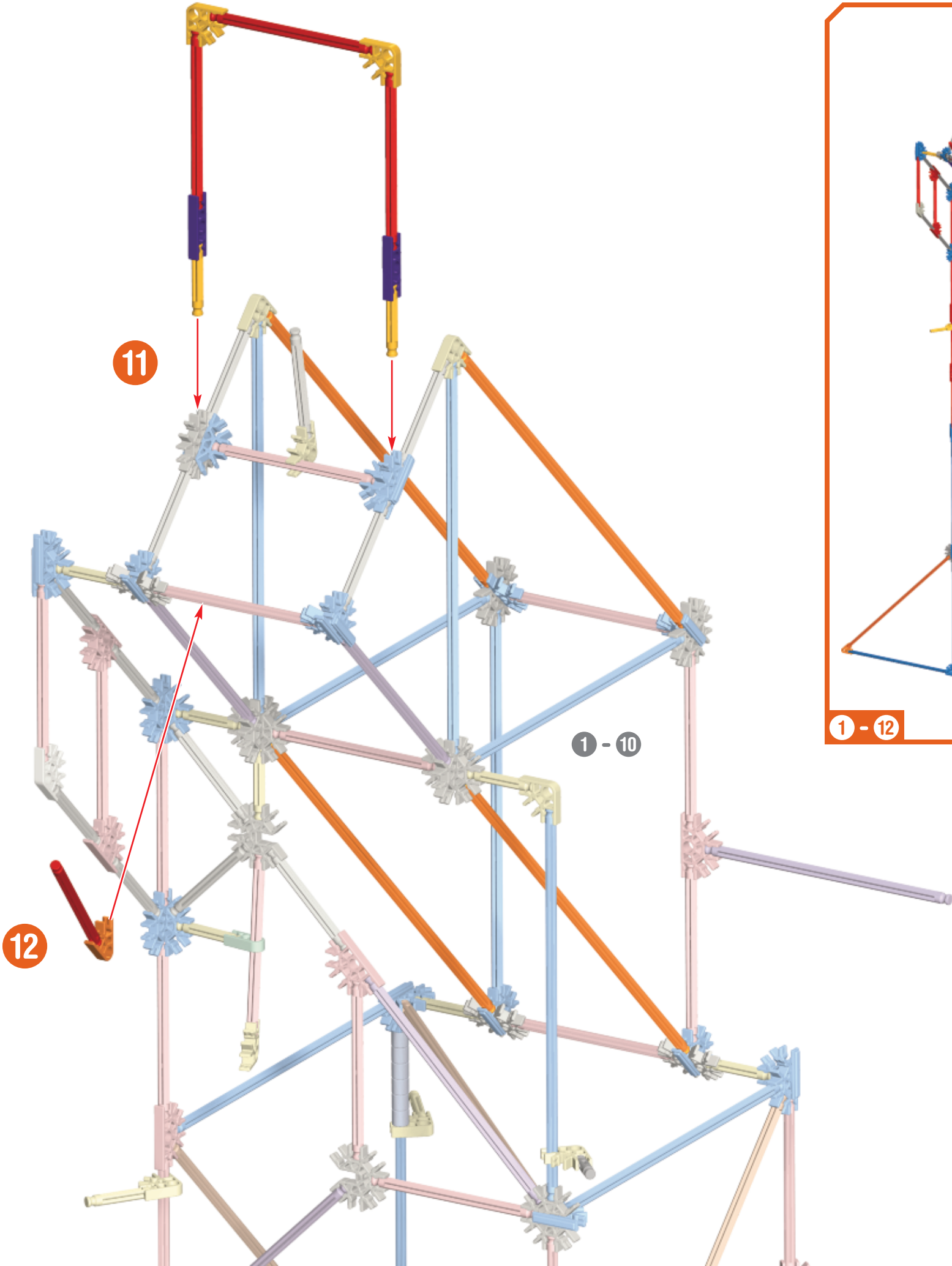

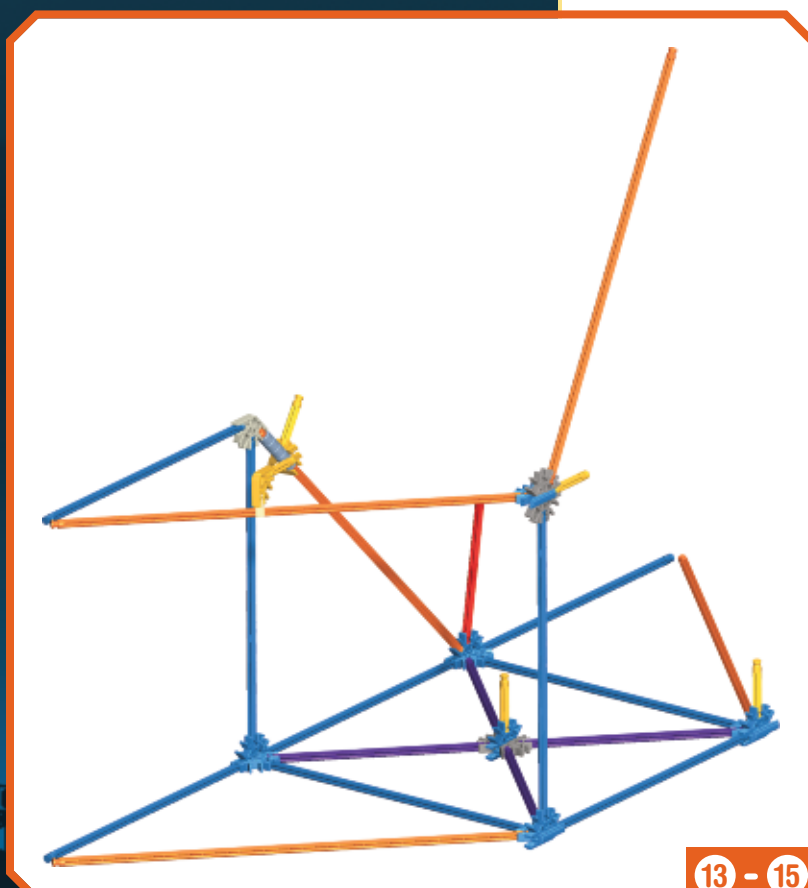
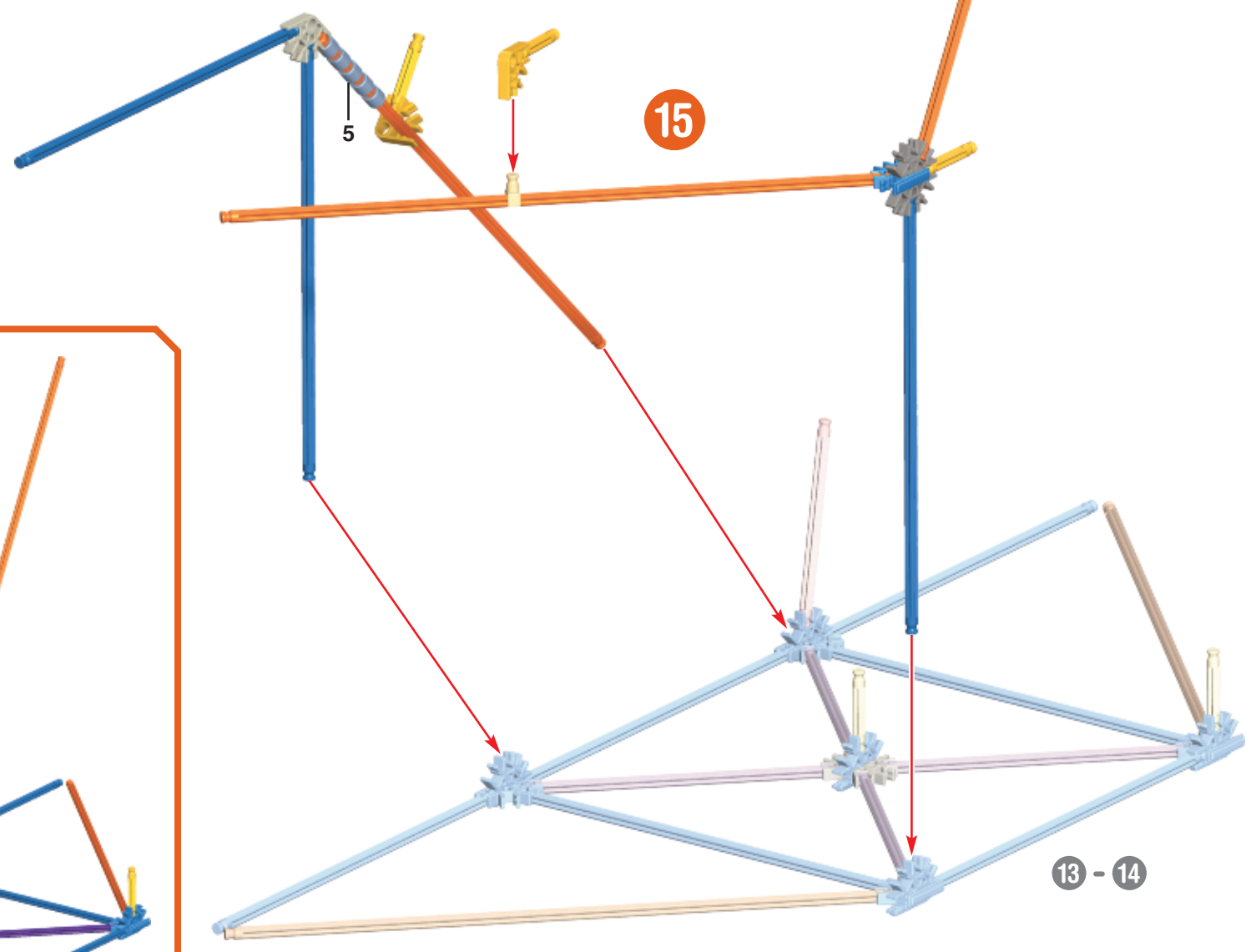
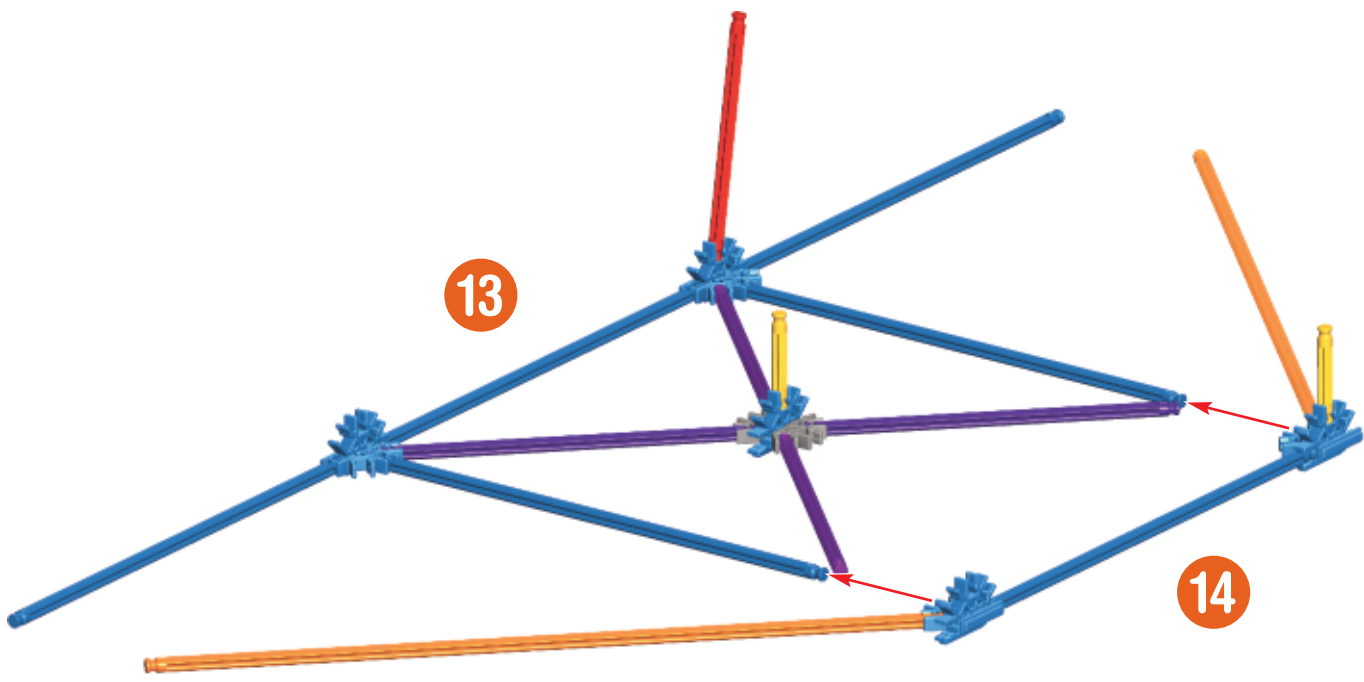

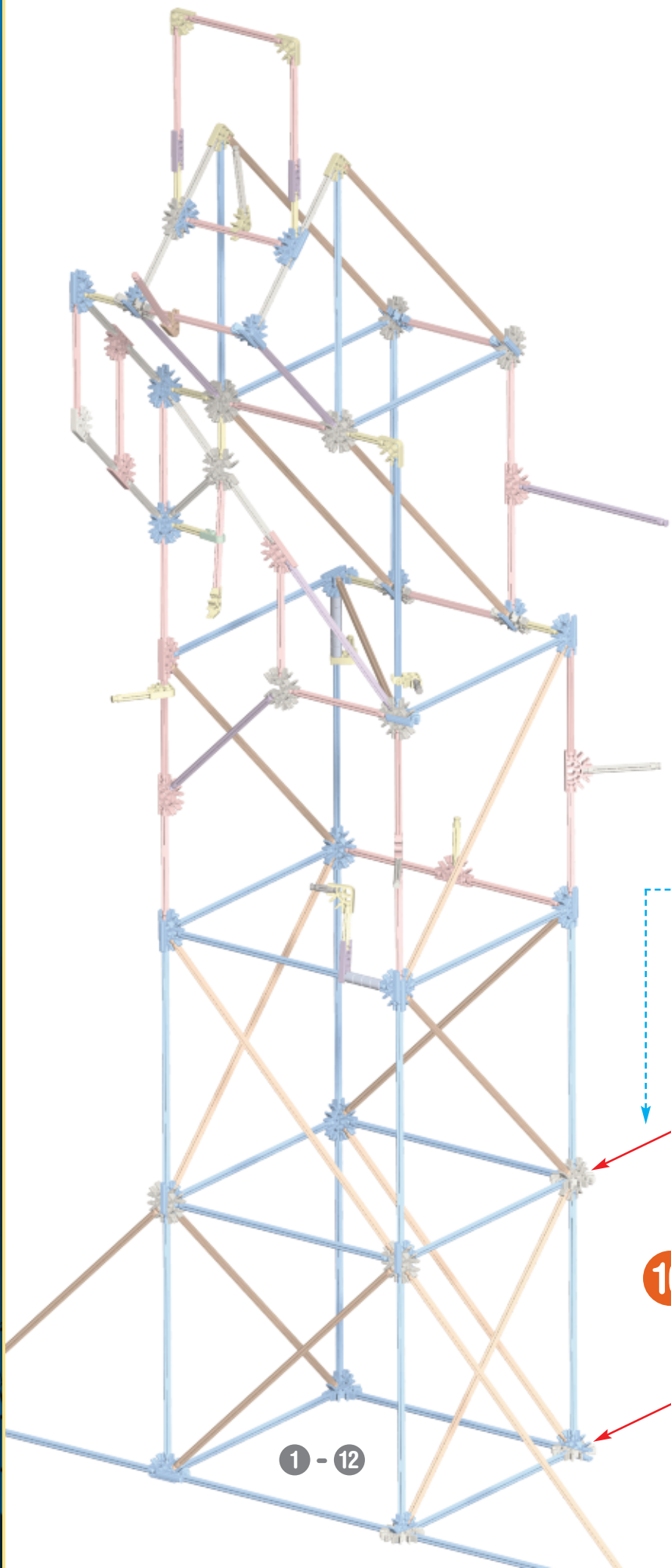

1 - 12

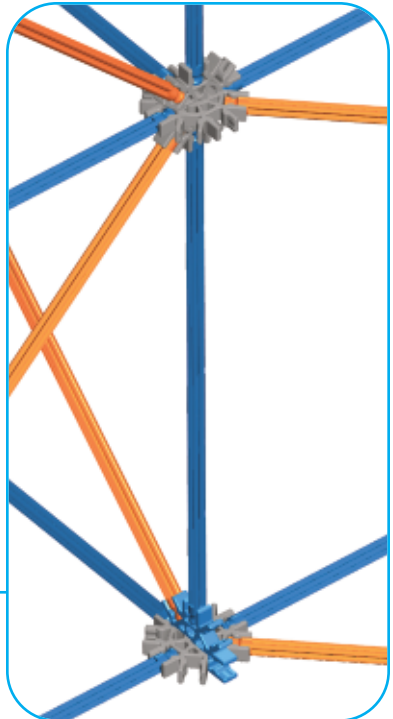

16

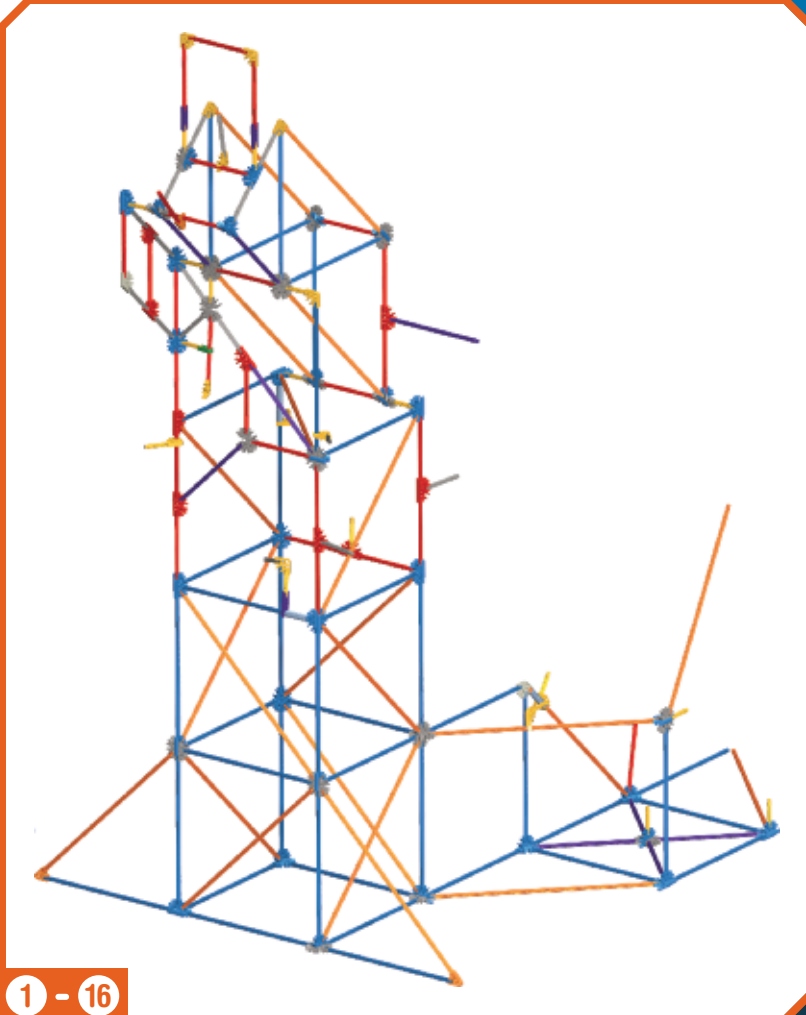

1 - 16

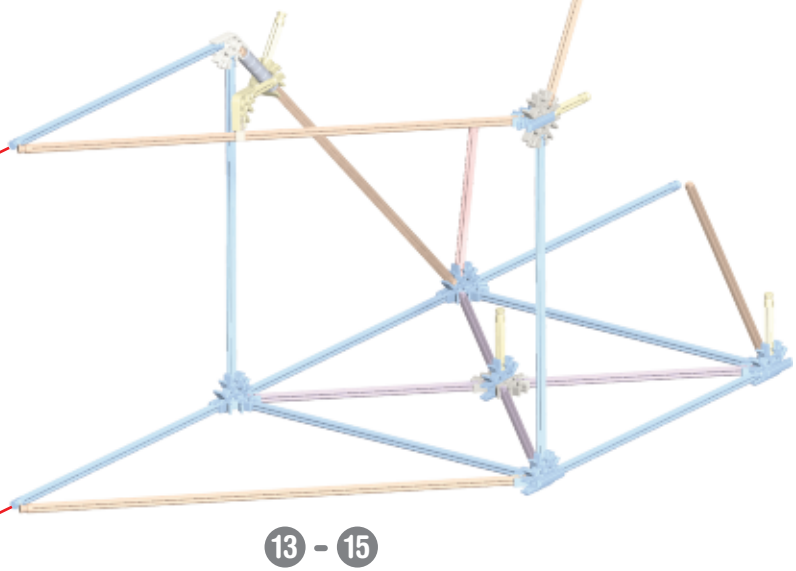

13 - 15



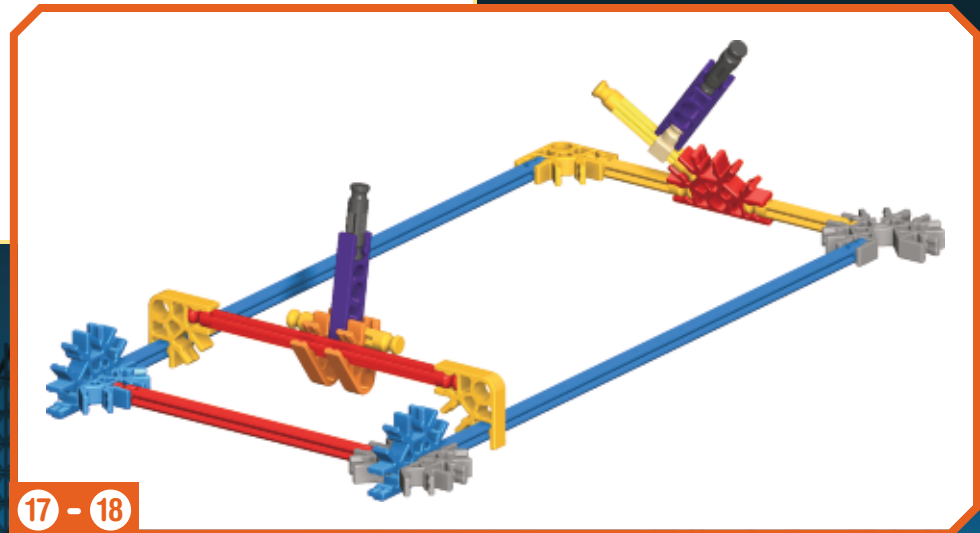
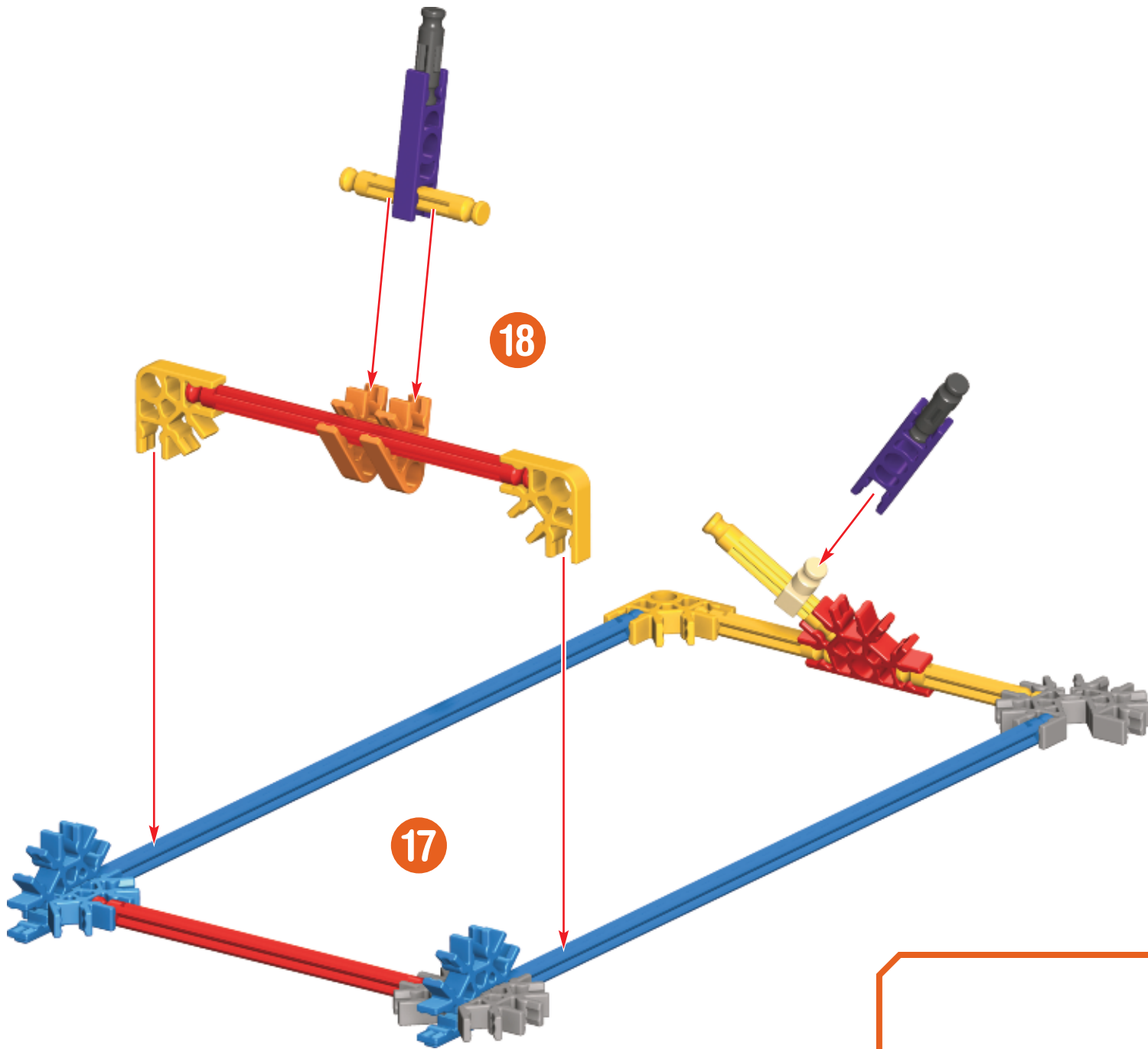

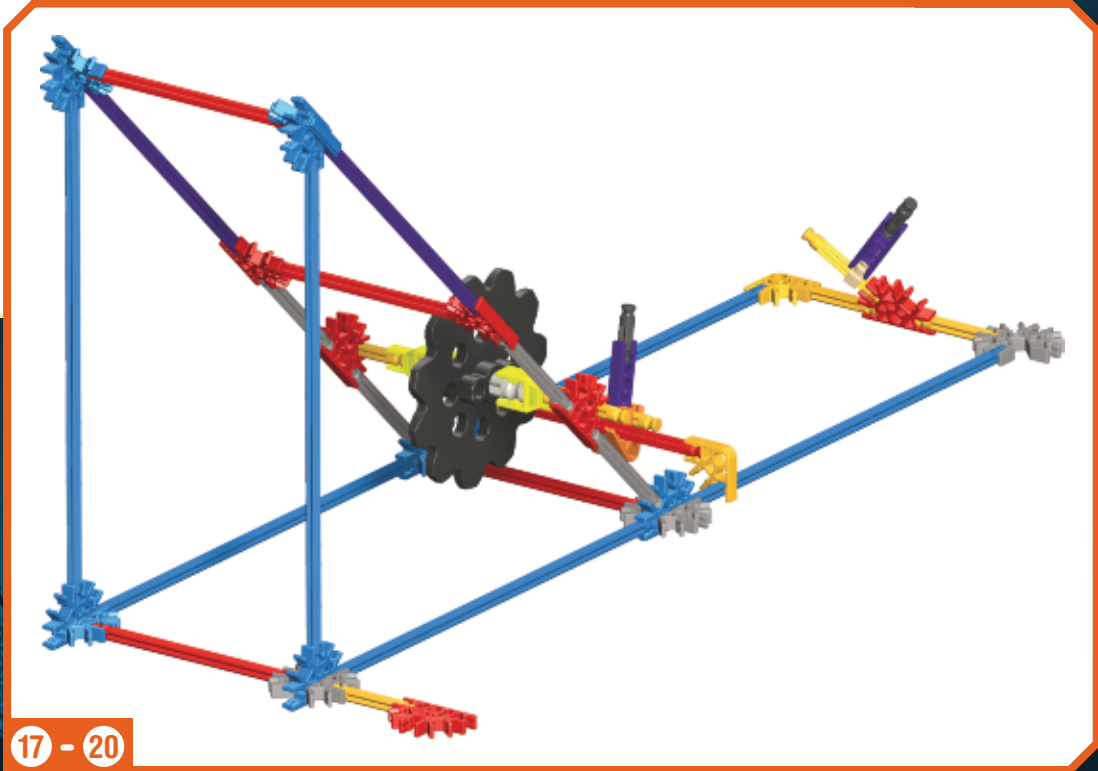
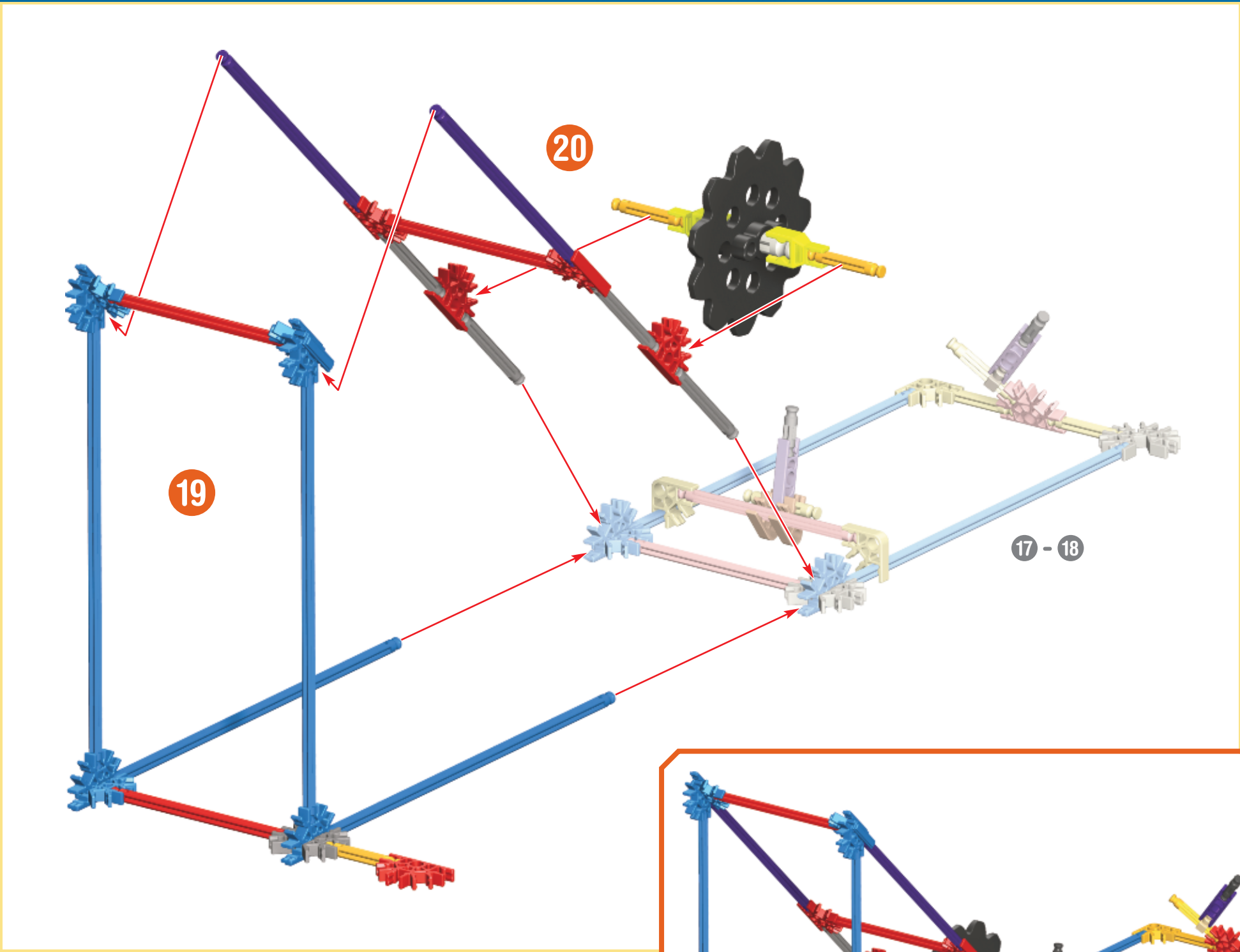

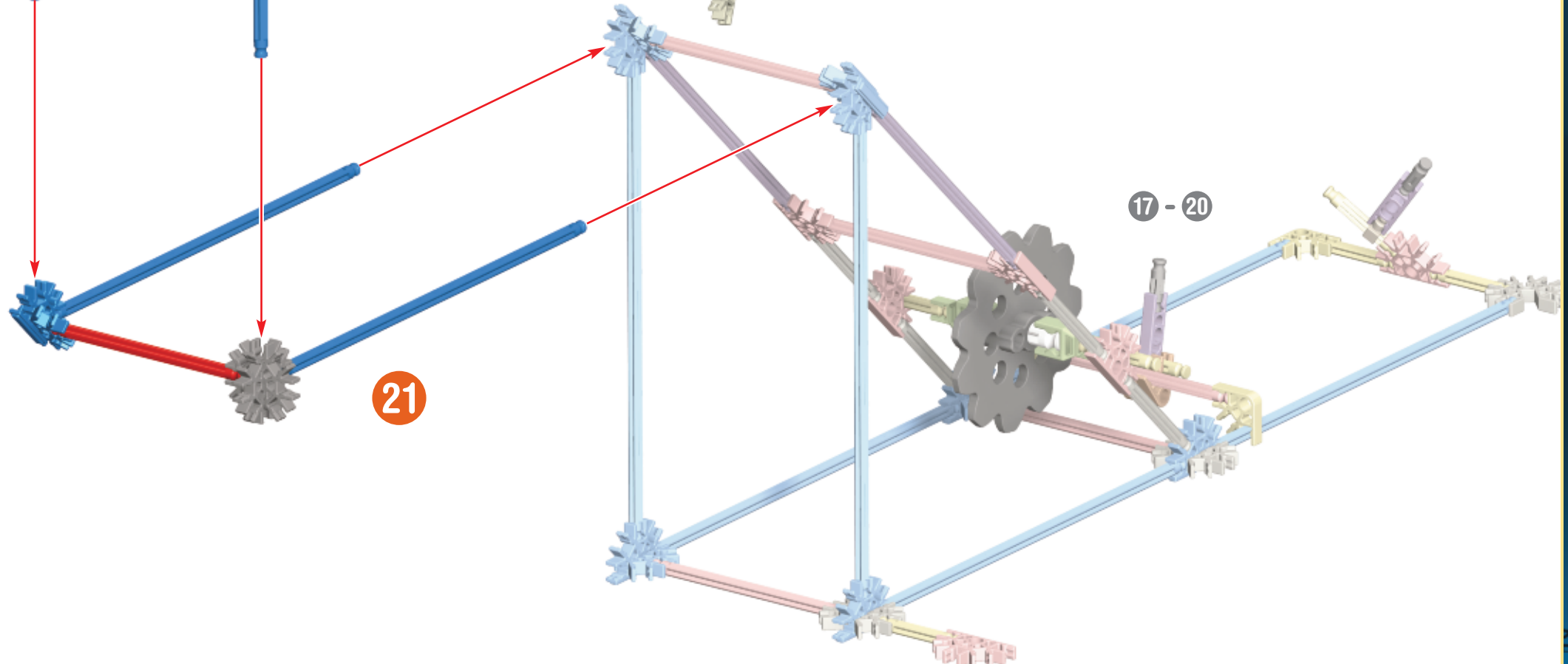
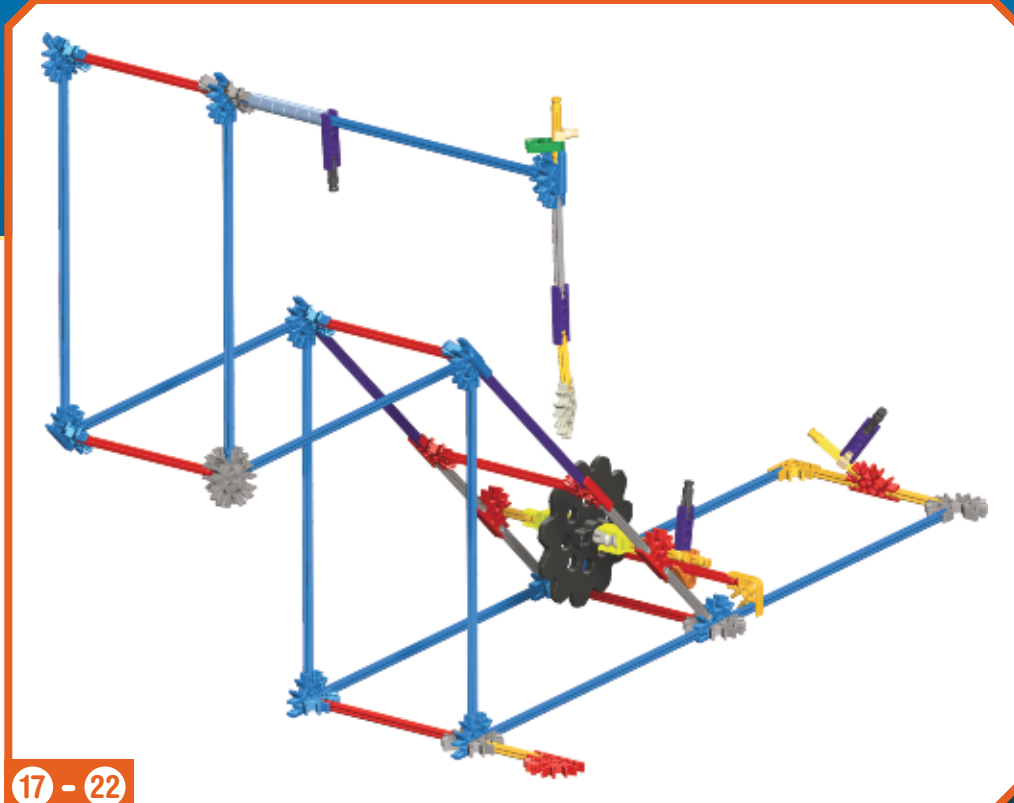
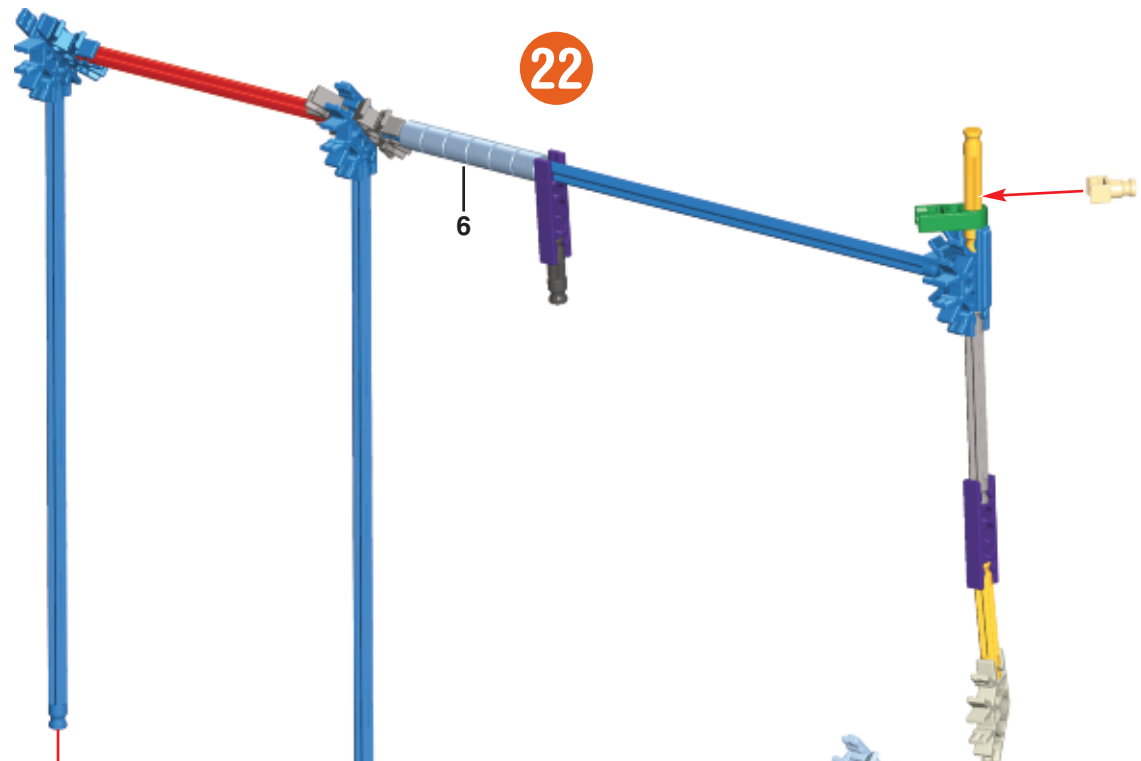

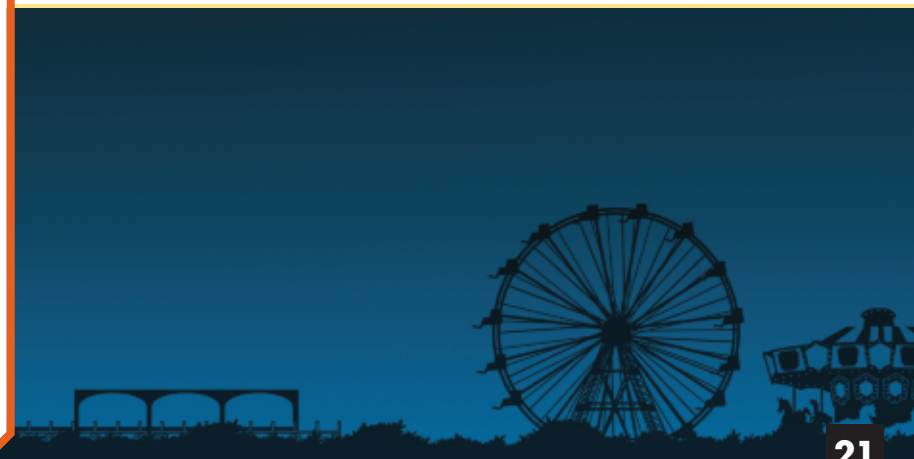
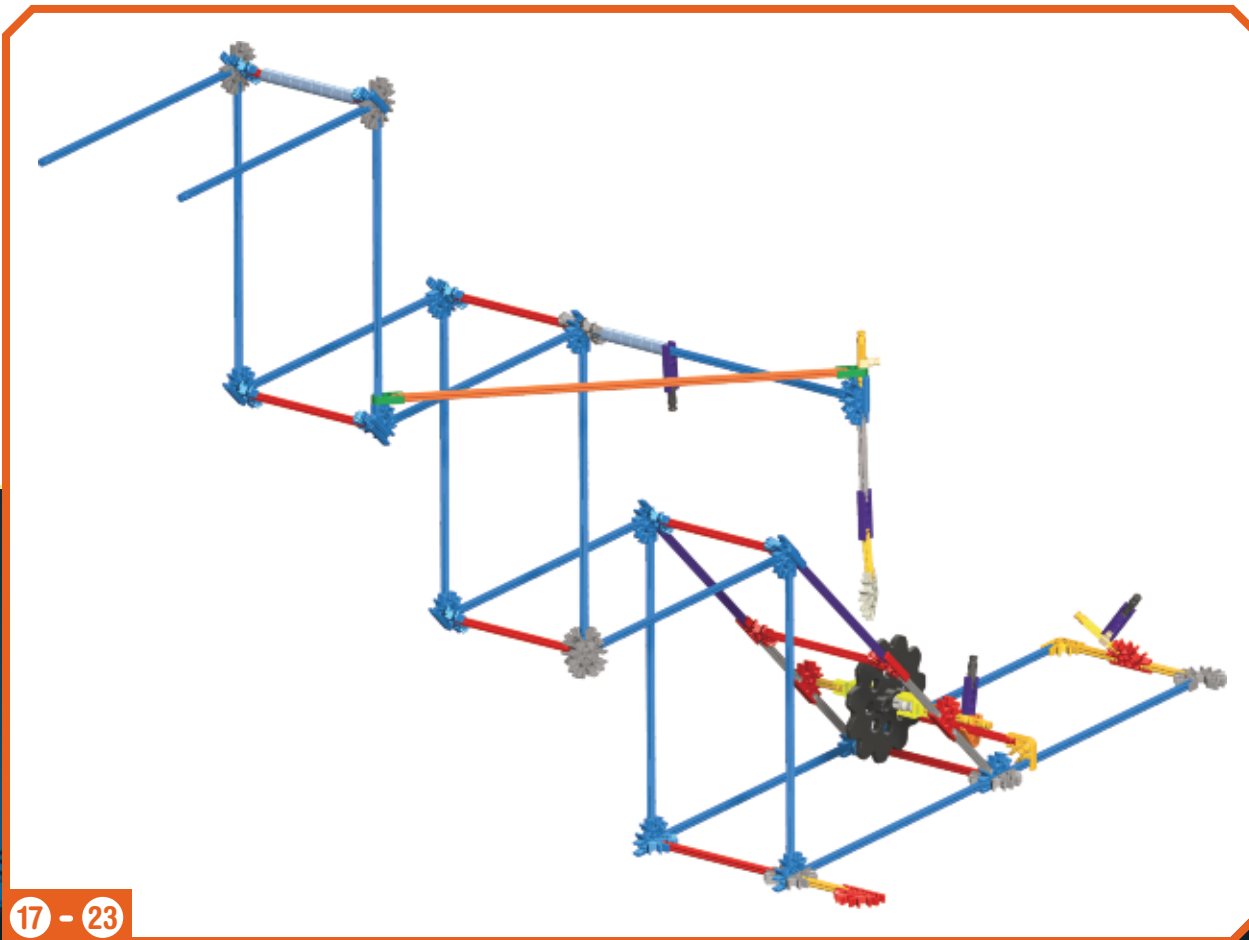
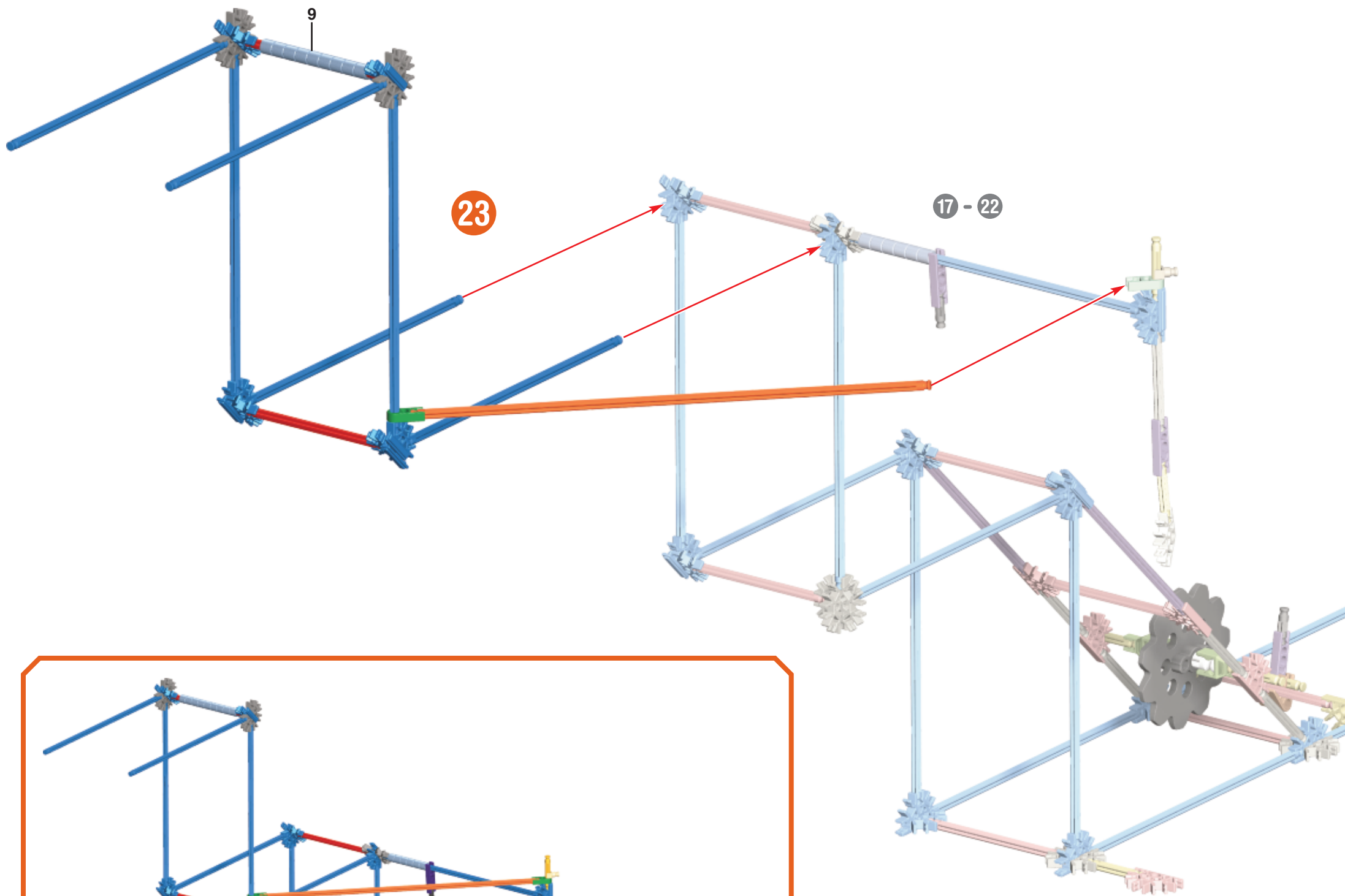

24

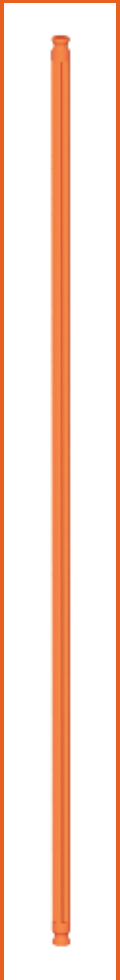
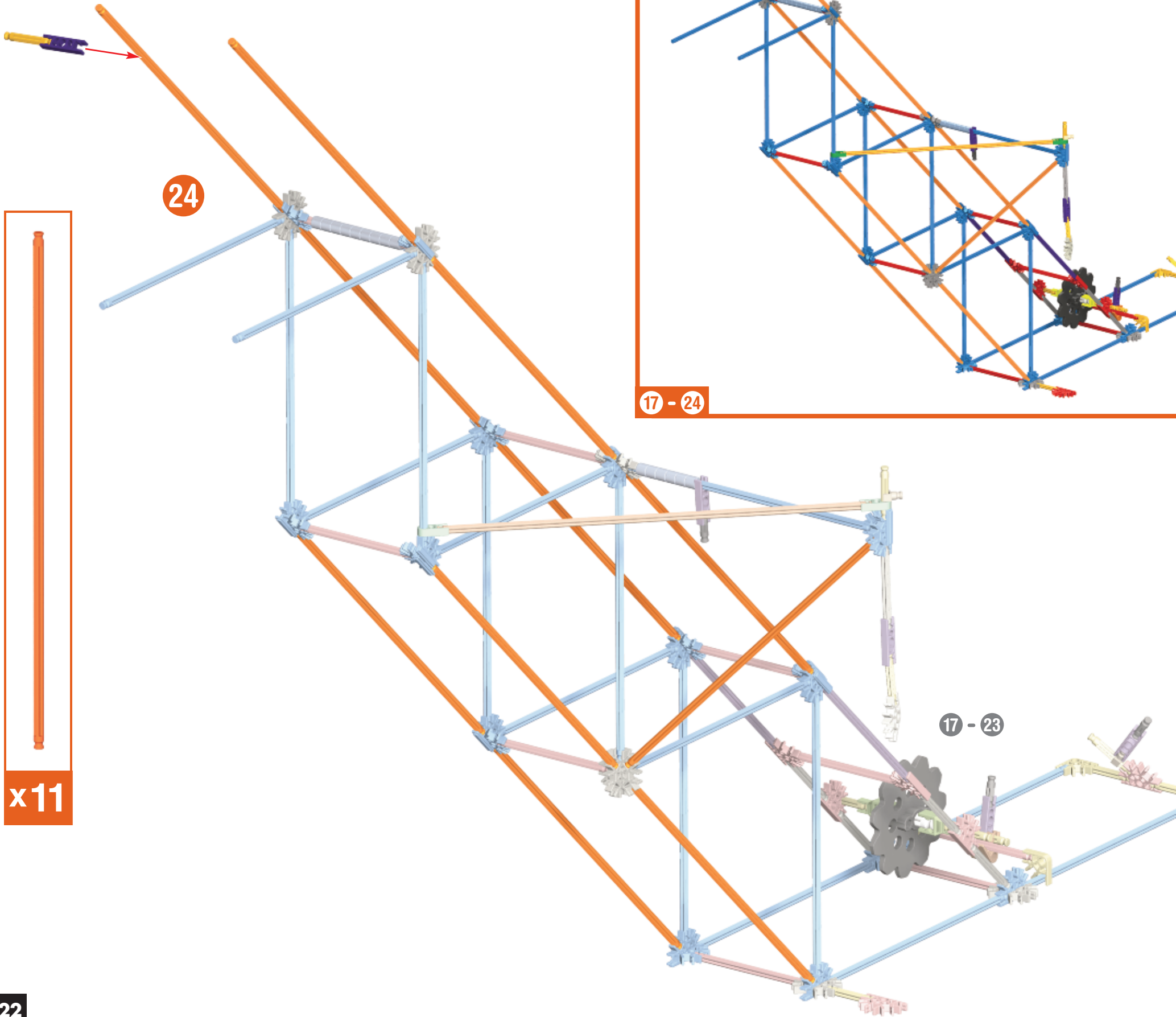

x11

17 - 24

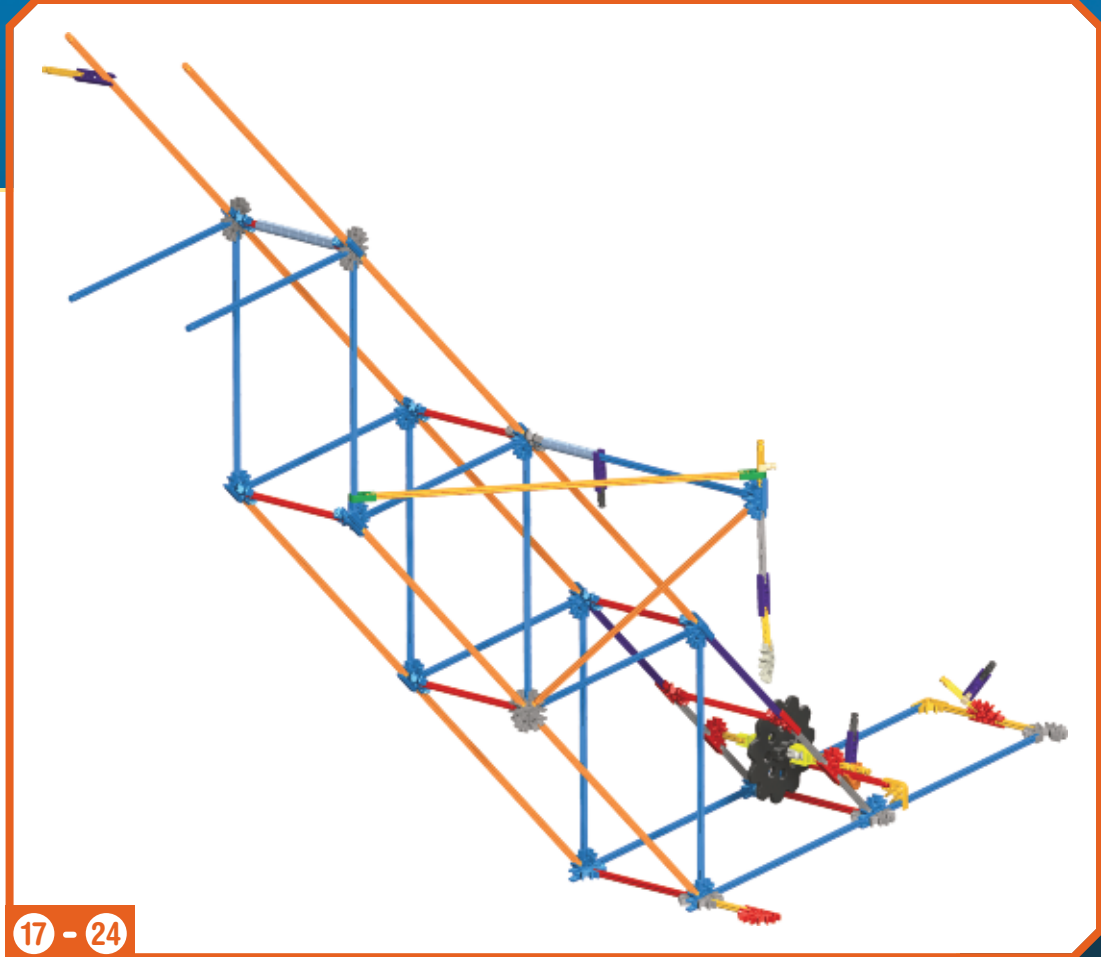

17 - 23

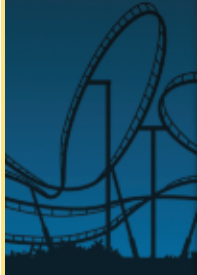

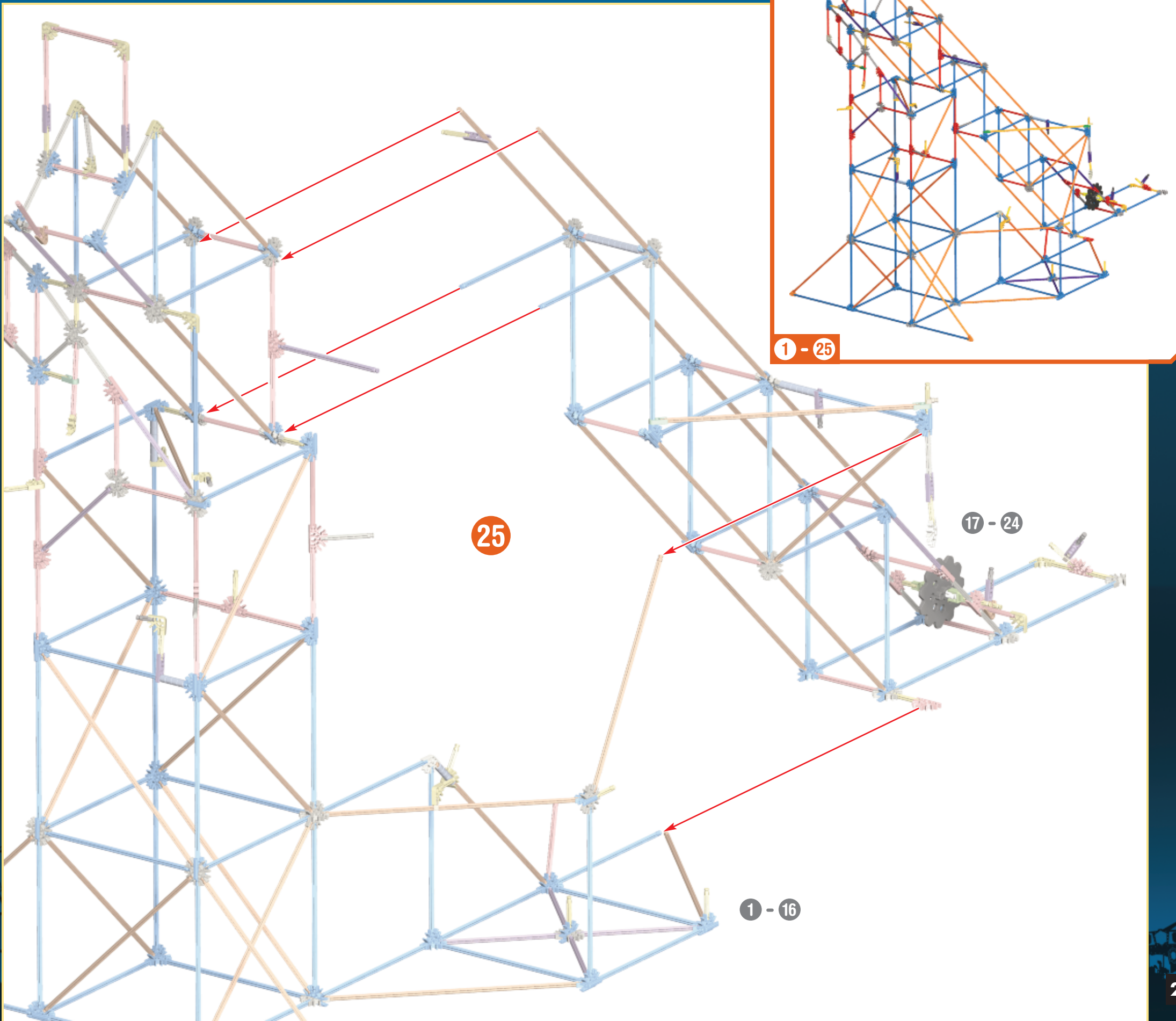

1 - 25

25

17 - 24

1 - 16

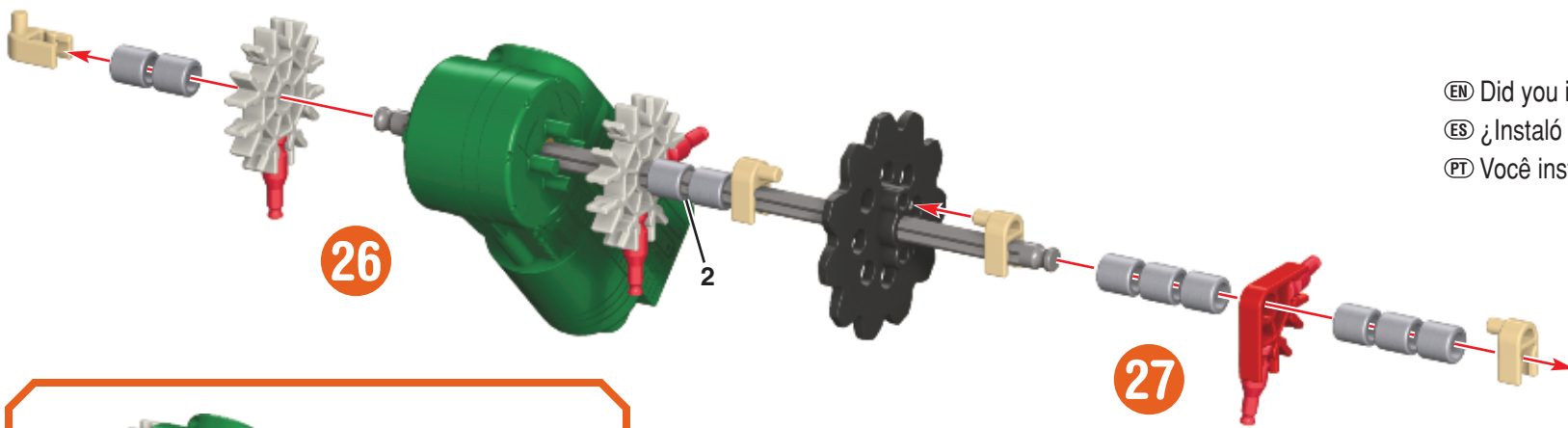

EN Did you install 2 AA (or LR6) batteries in the motor?

ES ¿Instaló 2 baterías AA (o LR6) en el motor?

PT Você instalou 2 pilhas AA (ou LR6) no motor?

26

27

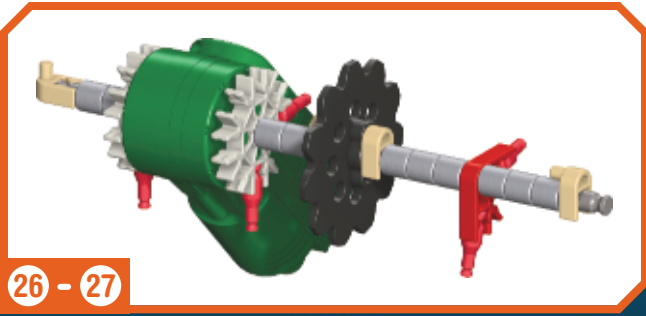

26 - 27

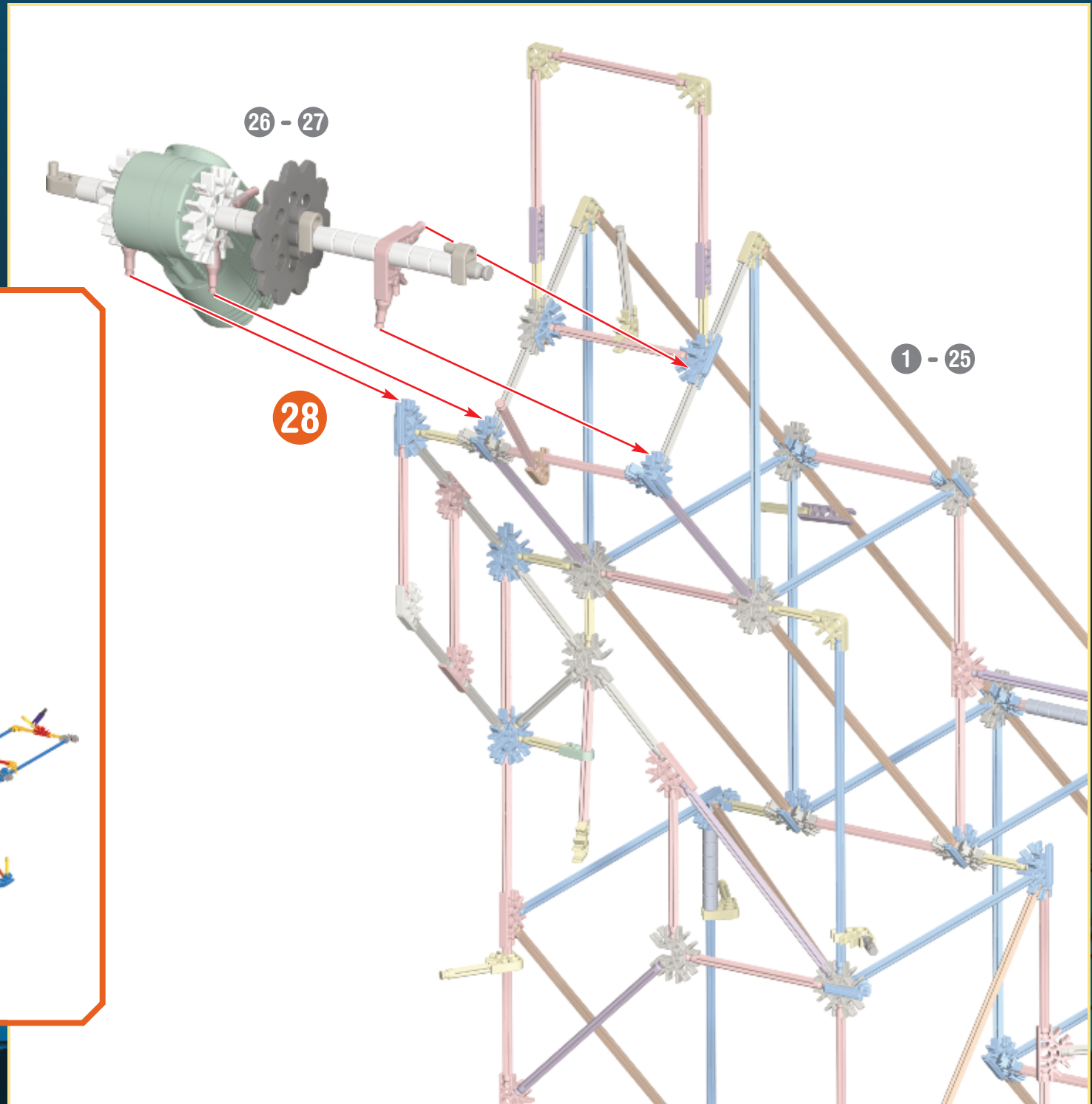

26 - 27

1 - 25

28

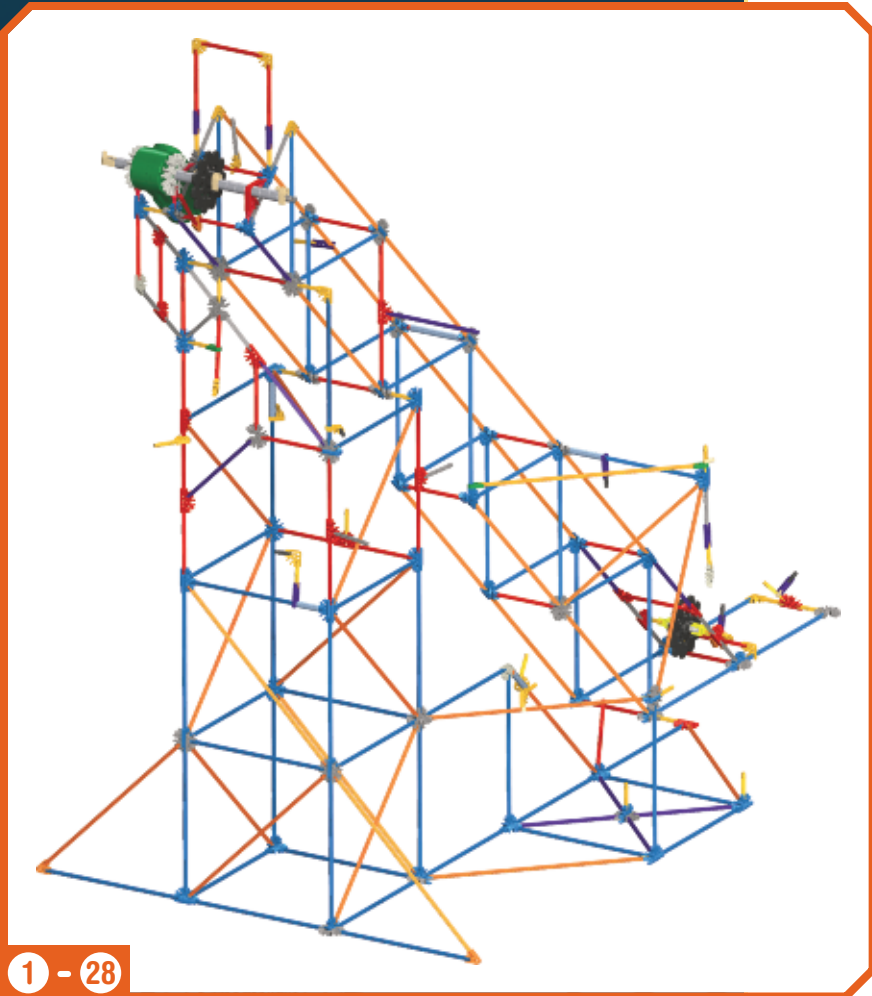

1 - 28

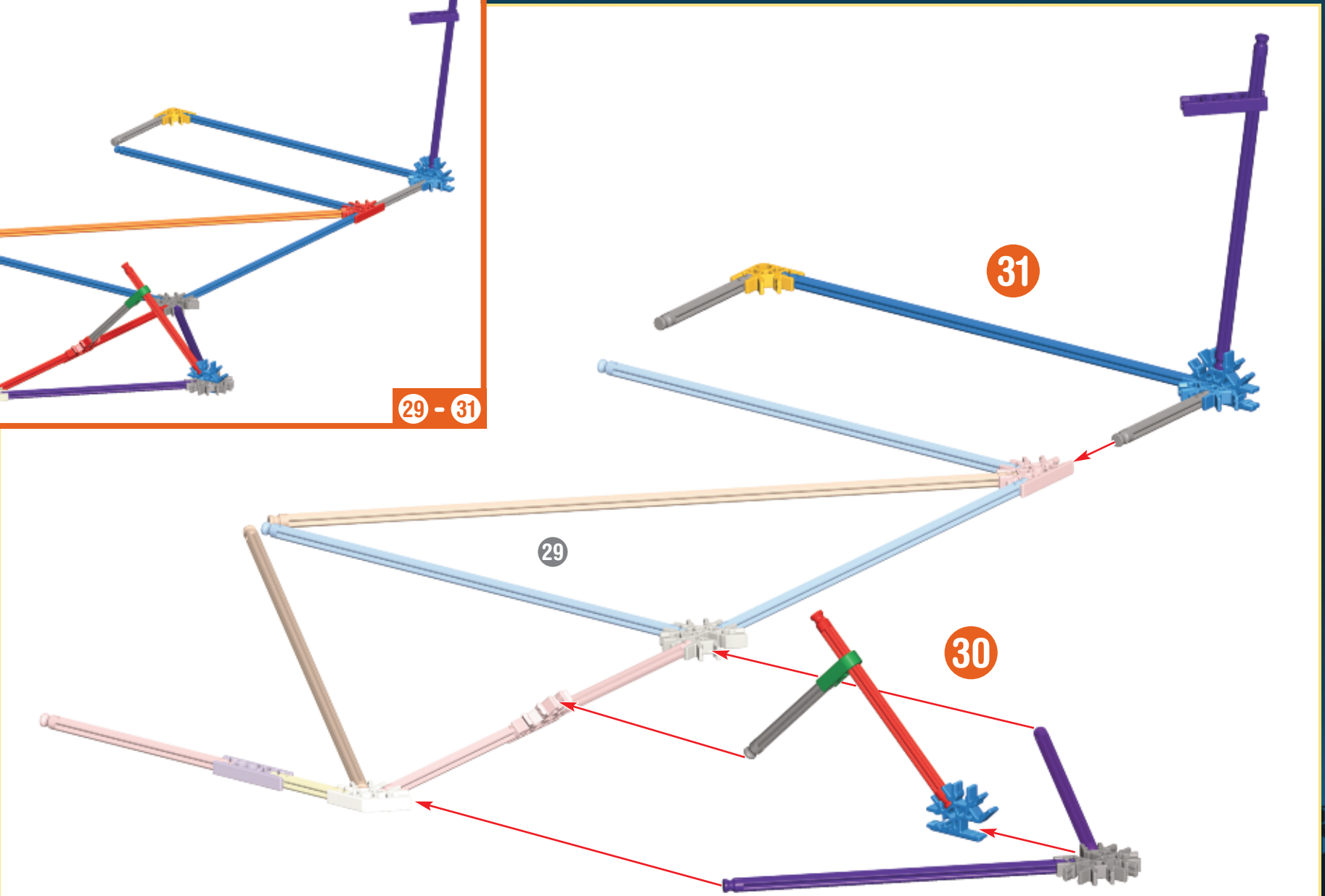
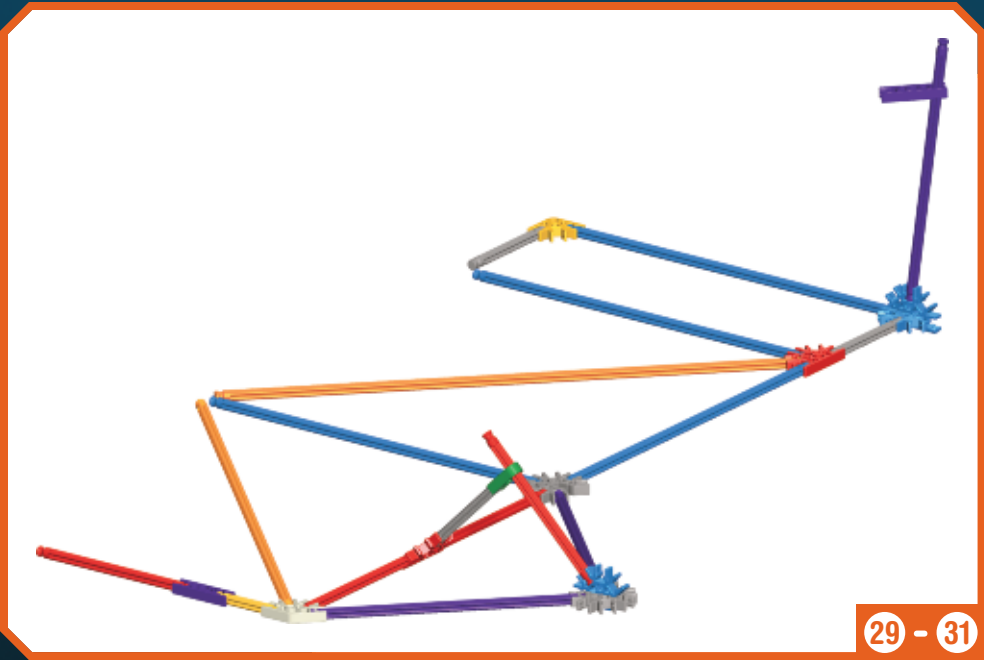
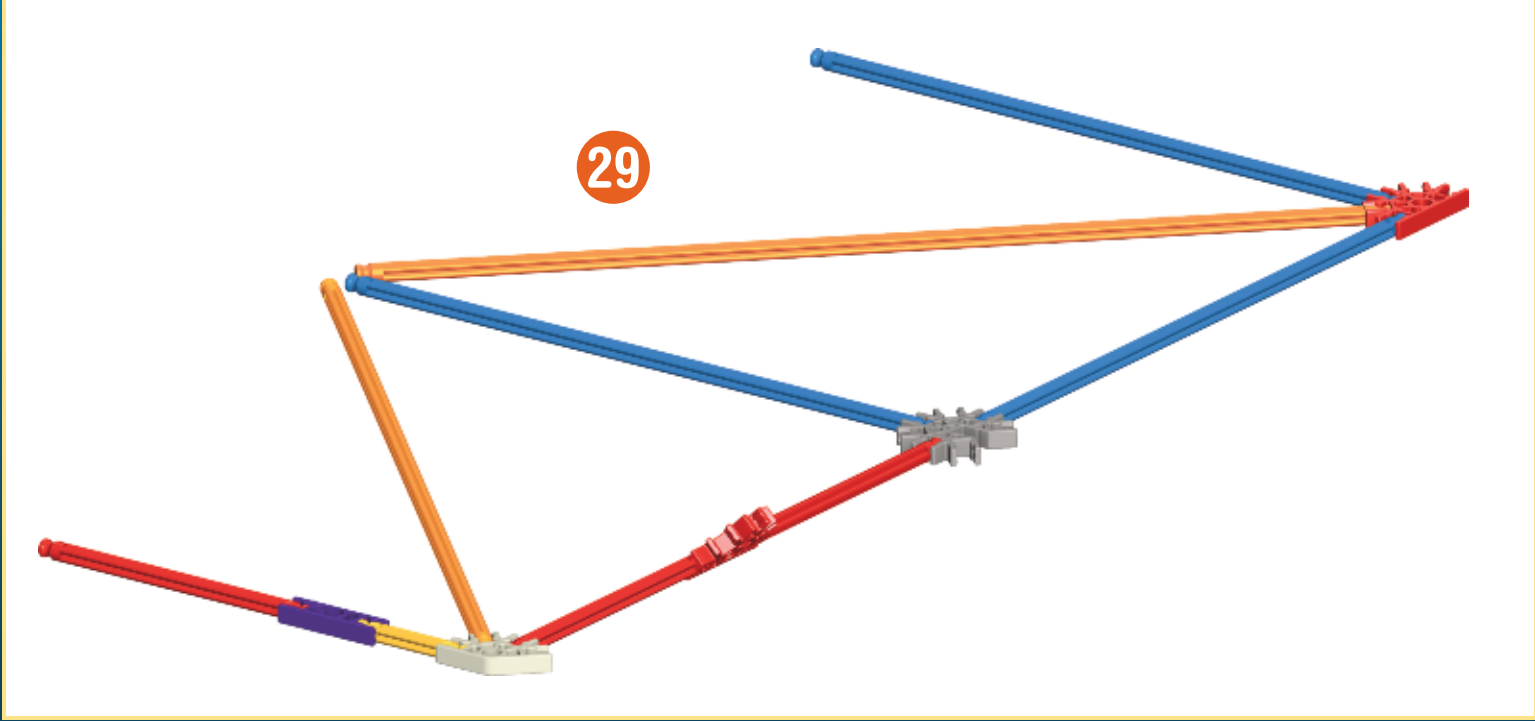

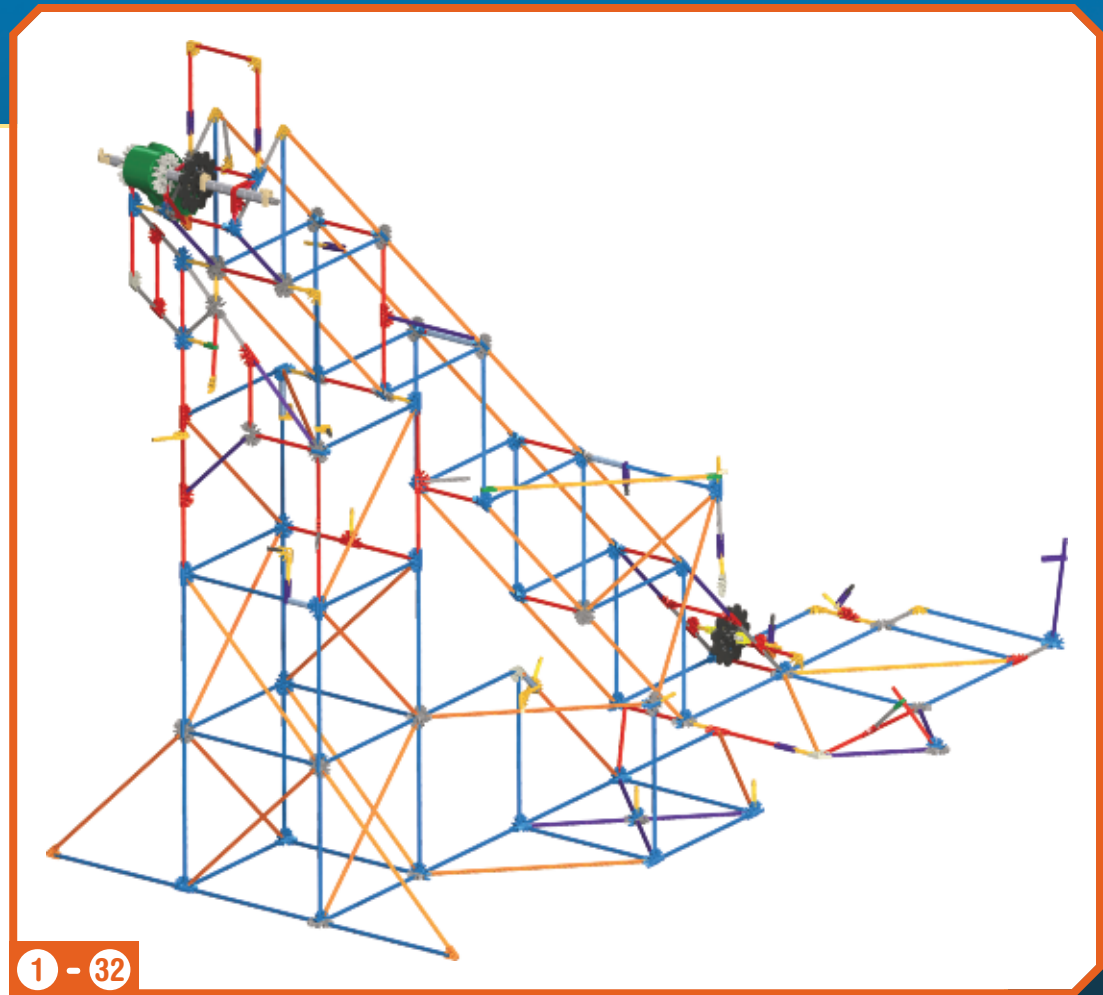

1 - 32

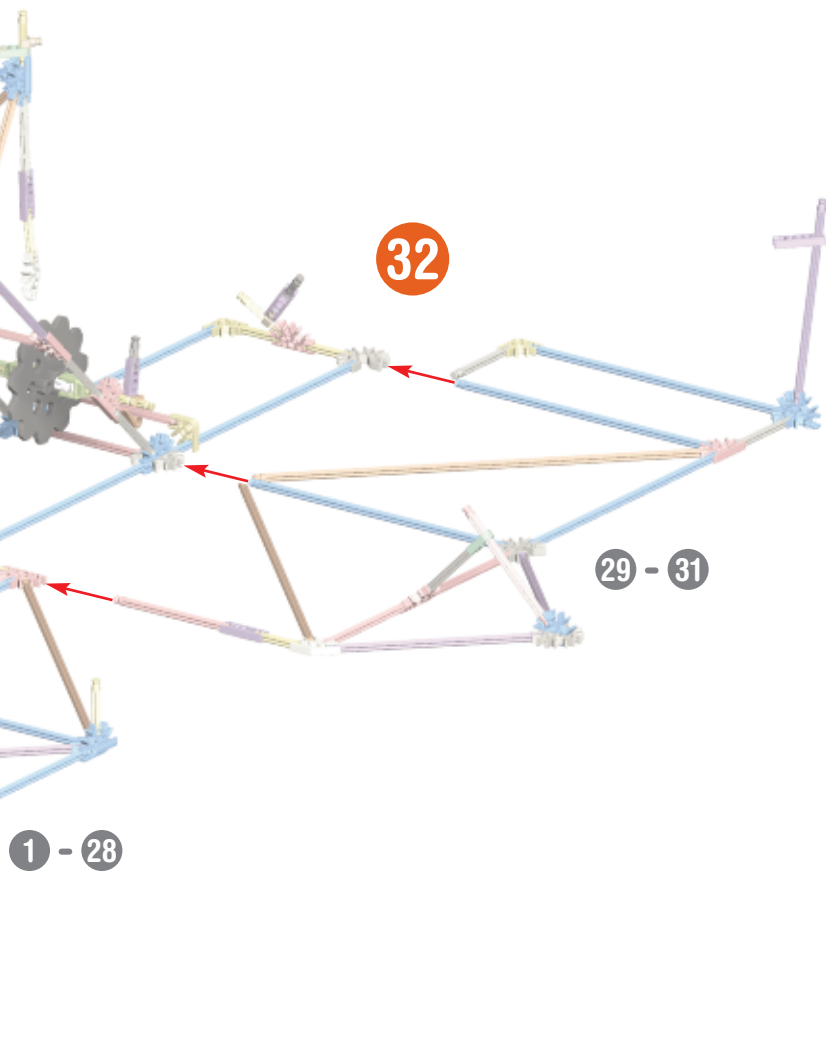

32

29 - 31

1 - 28

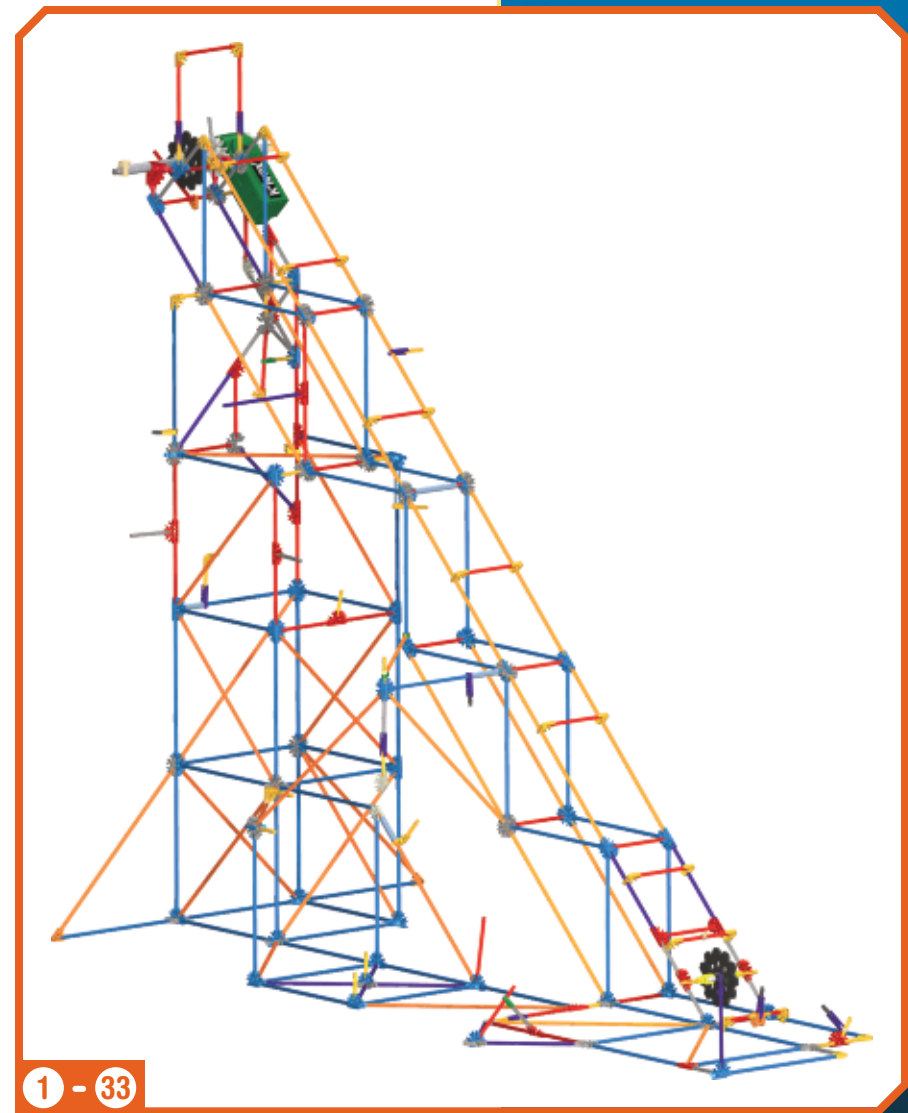
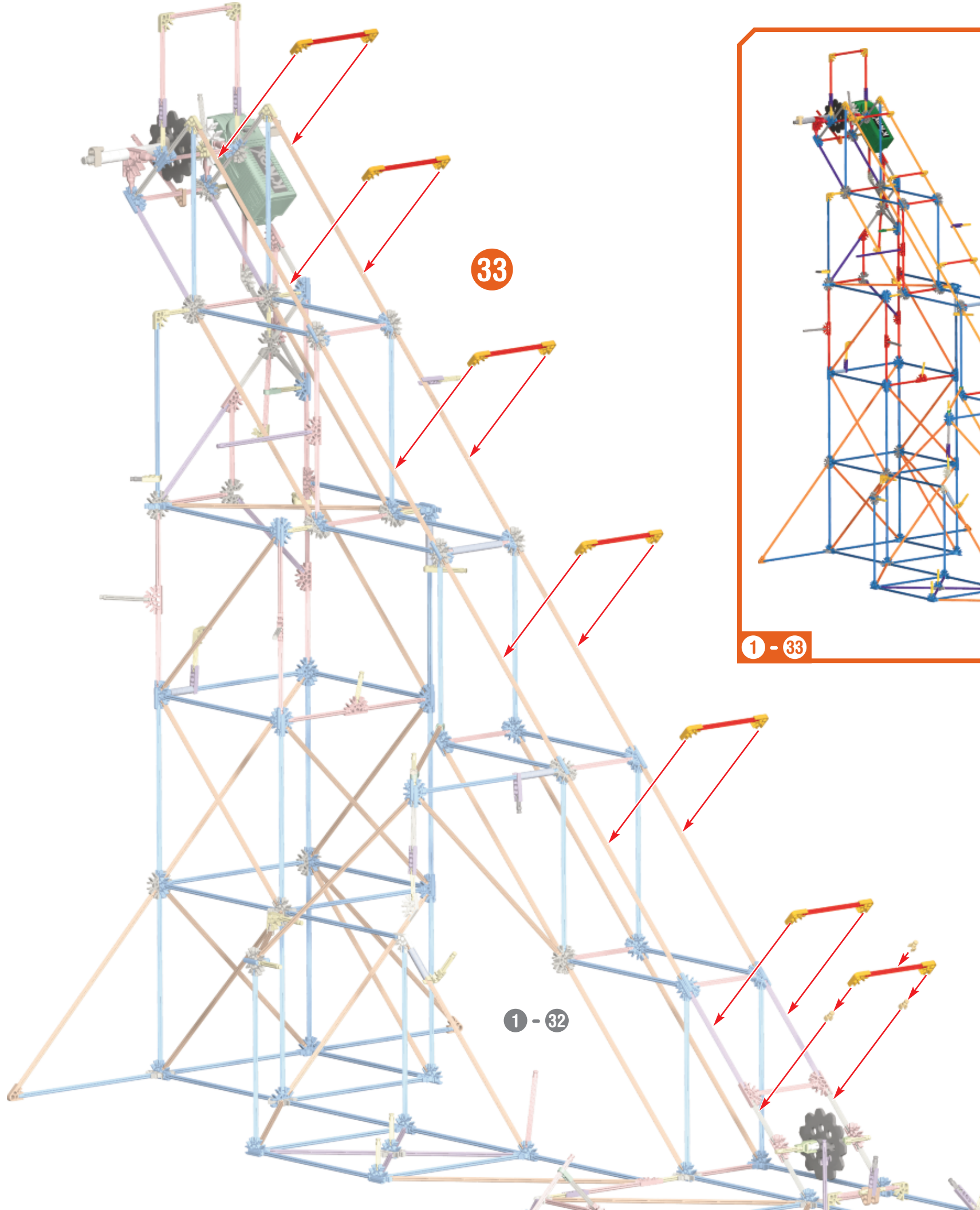

EN Track Building Tips:

Attach the black chain guides to the top of the track and attach the connectors to the bottom of the track exactly as shown.

ES Consejos para armar las Pistas:

Una las guías de la cadena negra a la parte superior de la vía y fije los conectores a la parte inferior, exactamente como se muestra.

PT Dicas para a montagem dos trilhos

Conecte as guias da corrente negra ao topo do trilho e os conectores à parte inferior do trilho, exatamente como mostrado.

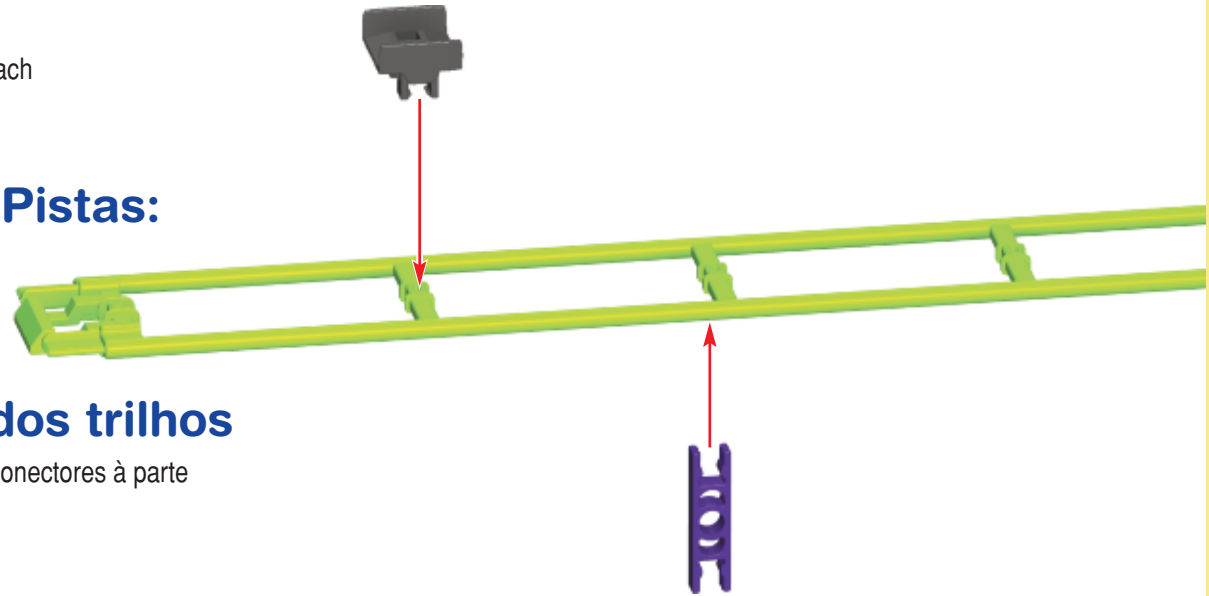

Be sure to push the connectors on firmly until they "click".

Asegúrese de apretar los conectores firmemente hasta que hagan "clic".

Empurre os conectores firmemente até ouvir um "clique".

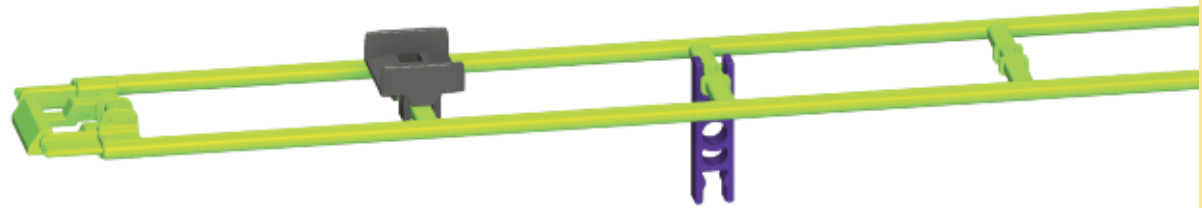

Always connect the track top side to top side throughout the build.

Siempre conecte la parte superior de la vía con el lado superior a lo largo de la construcción.

Sempre conecte o lado superior do trilho ao lado superior ao longo do modelo.

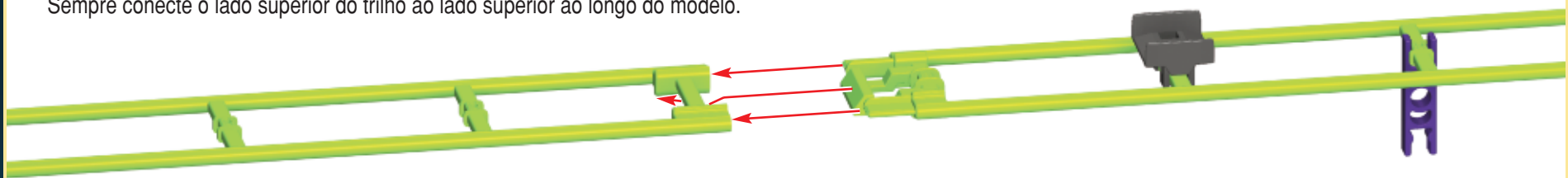

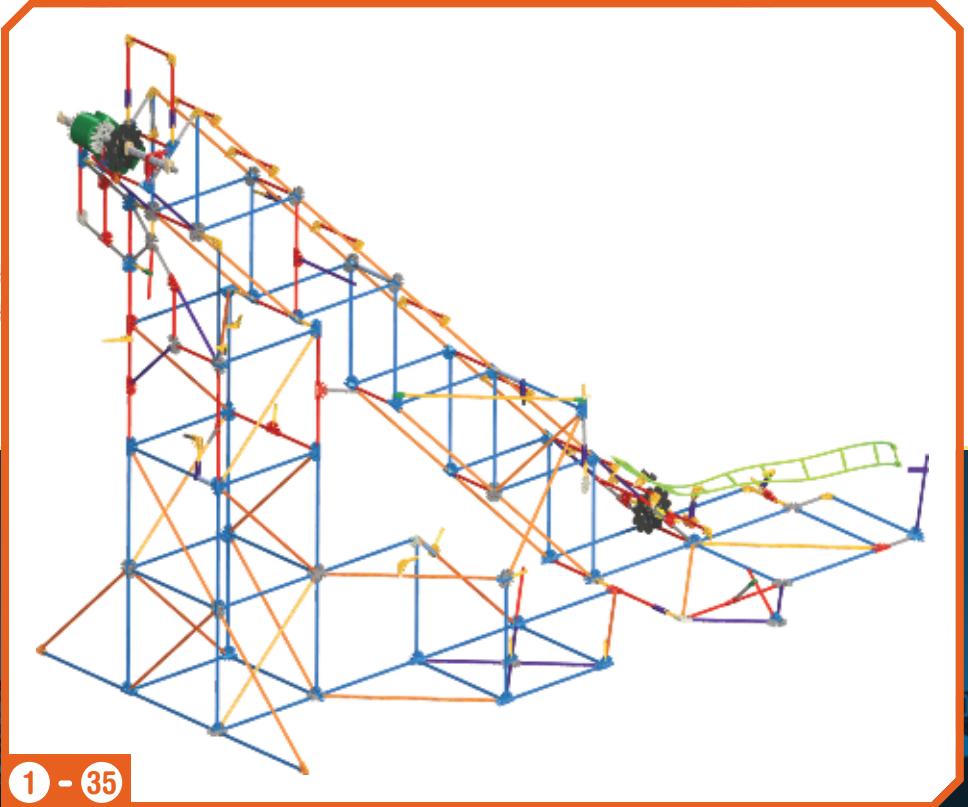
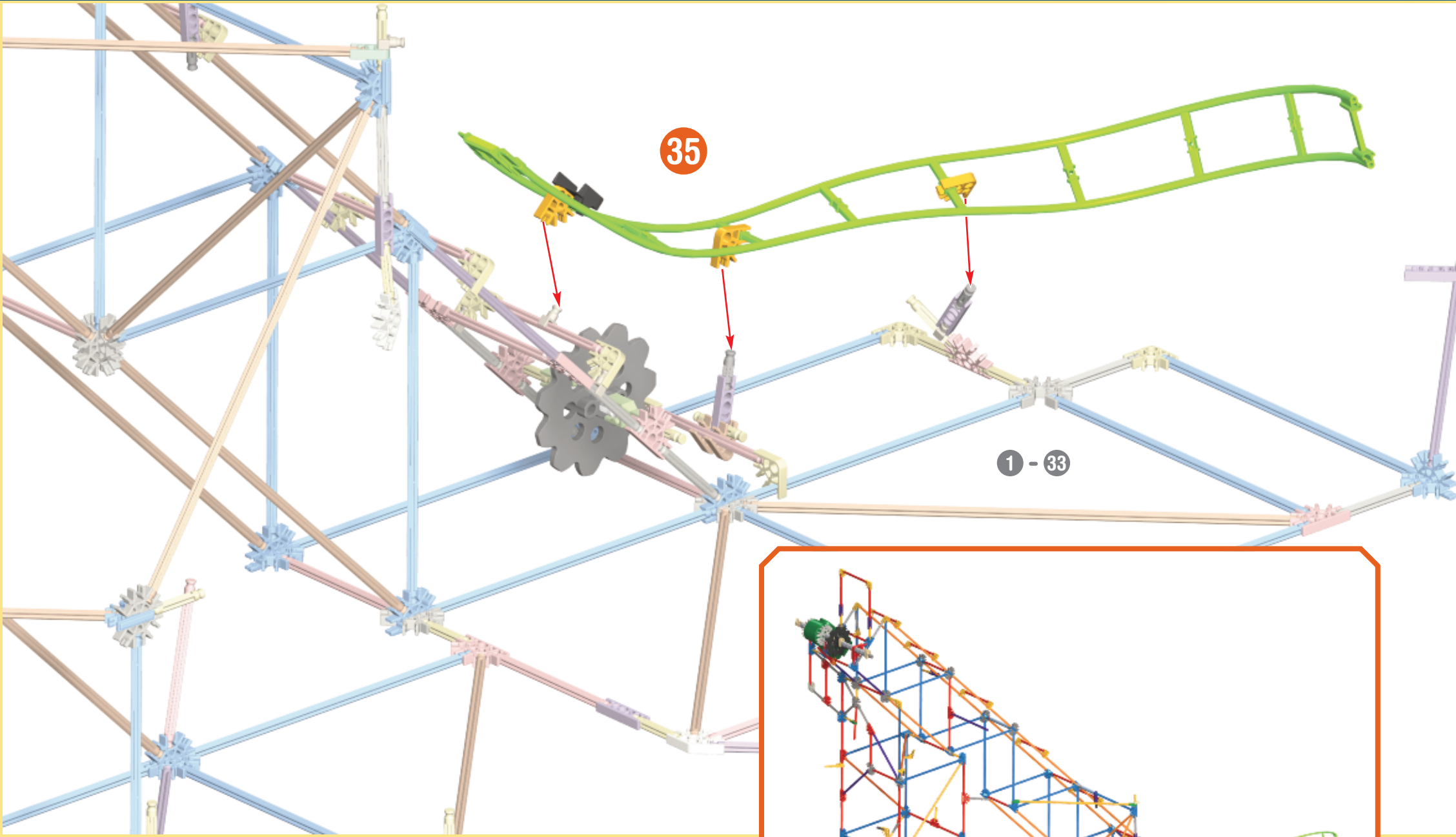
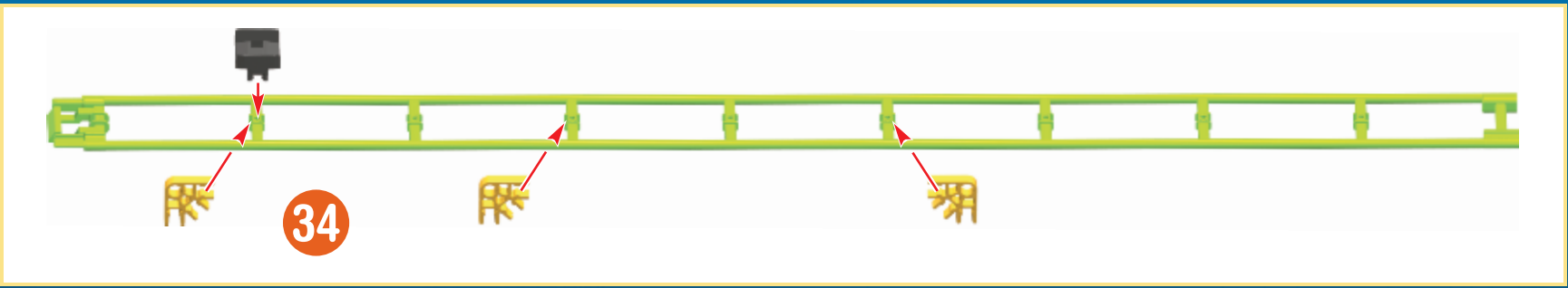

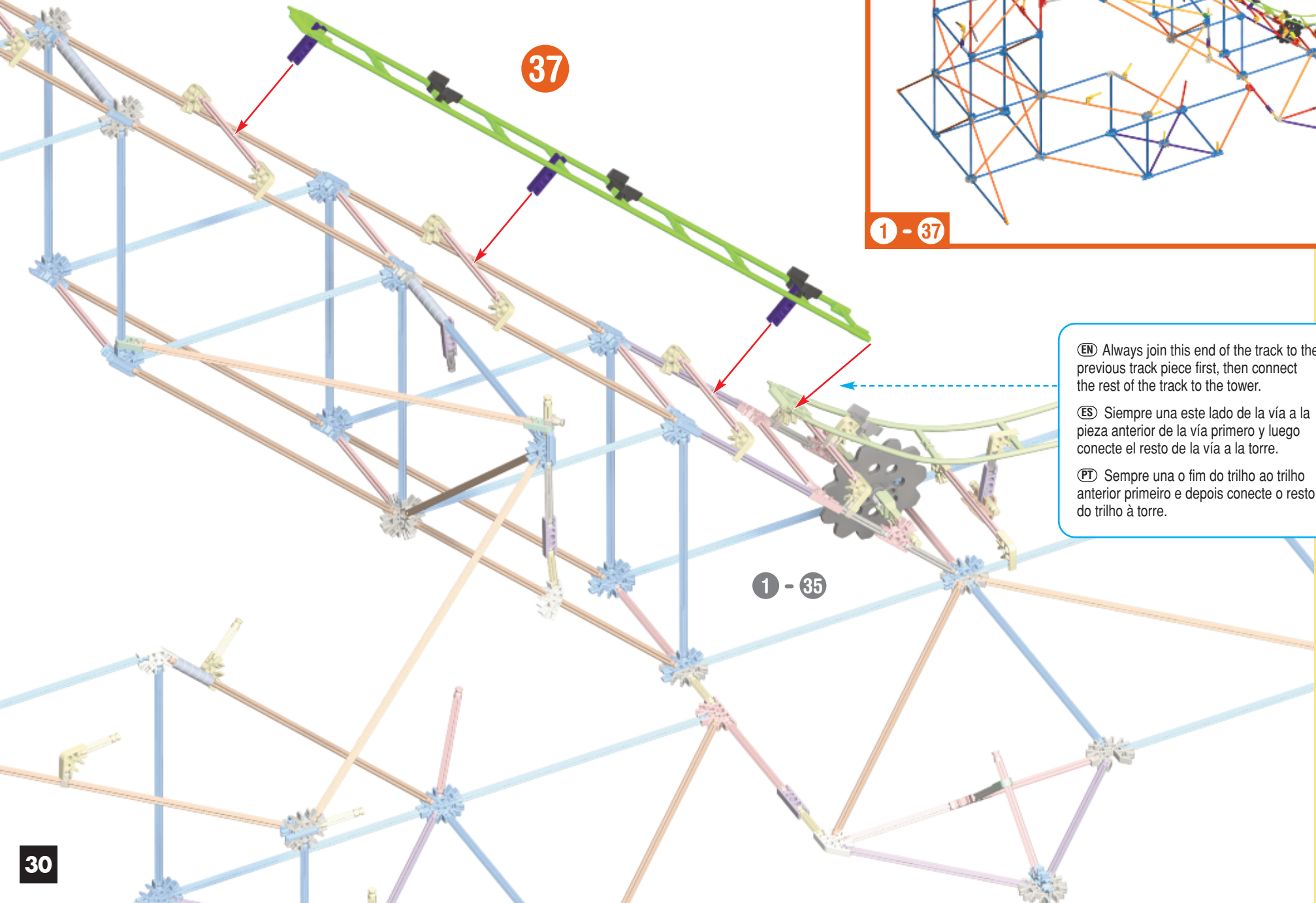
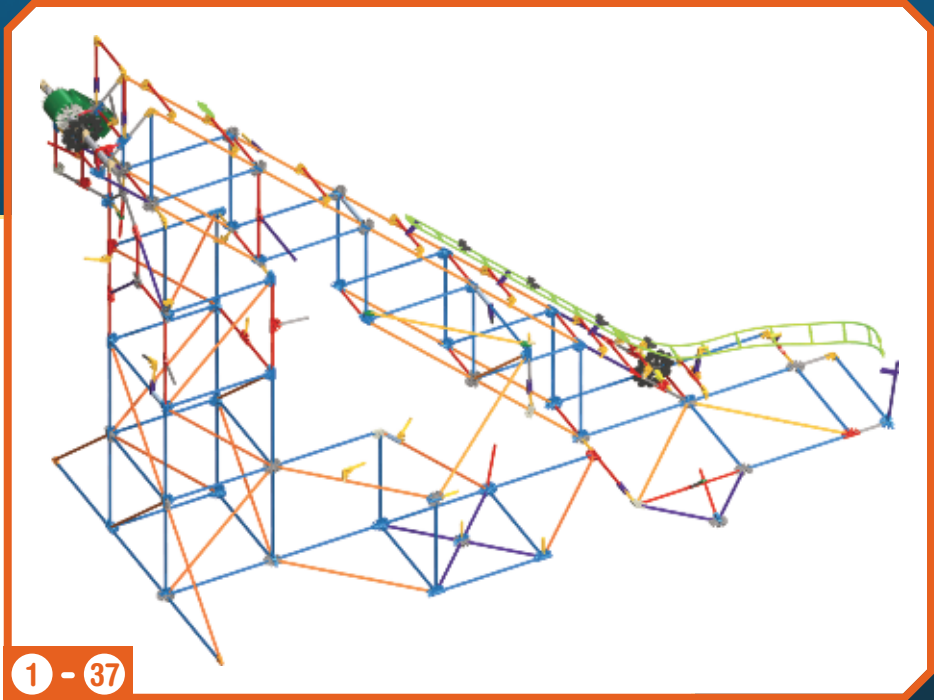
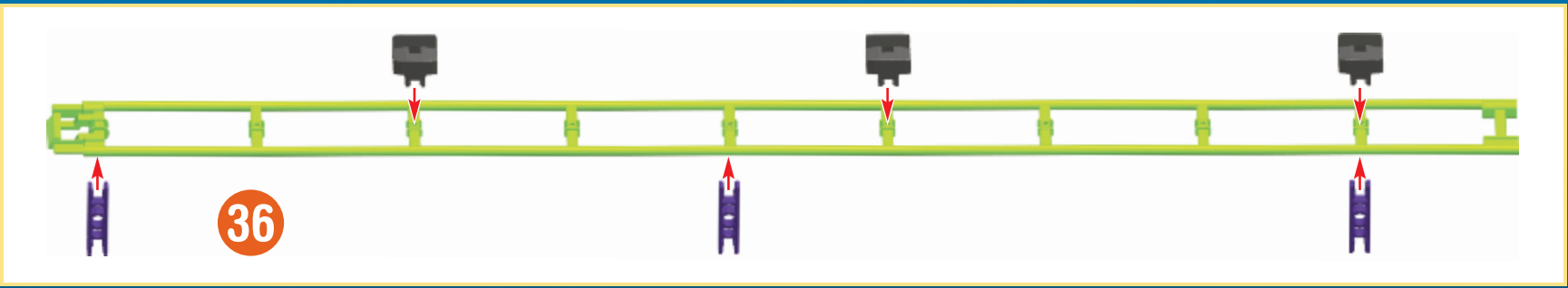

(EN) Always join this end of the track to the previous track piece first, then connect the rest of the track to the tower.
 (ES) Siempre una este lado de la vía a la pieza anterior de la vía primero y luego conecte el resto de la vía a la torre.
 (PT) Sempre una o fim do trilho ao trilho anterior primeiro e depois conecte o resto do trilho à torre.



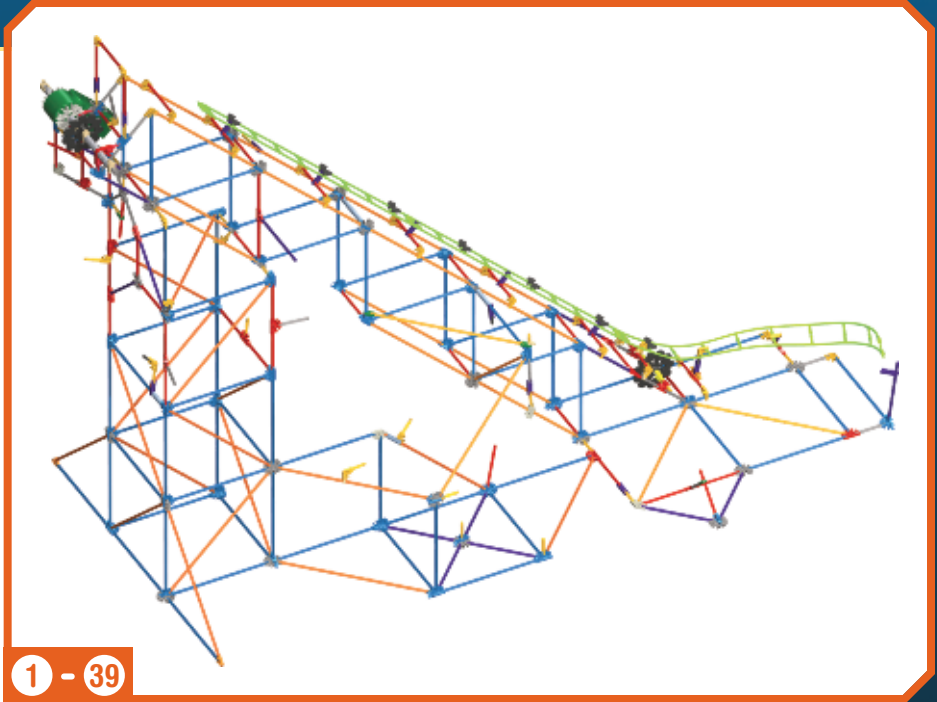
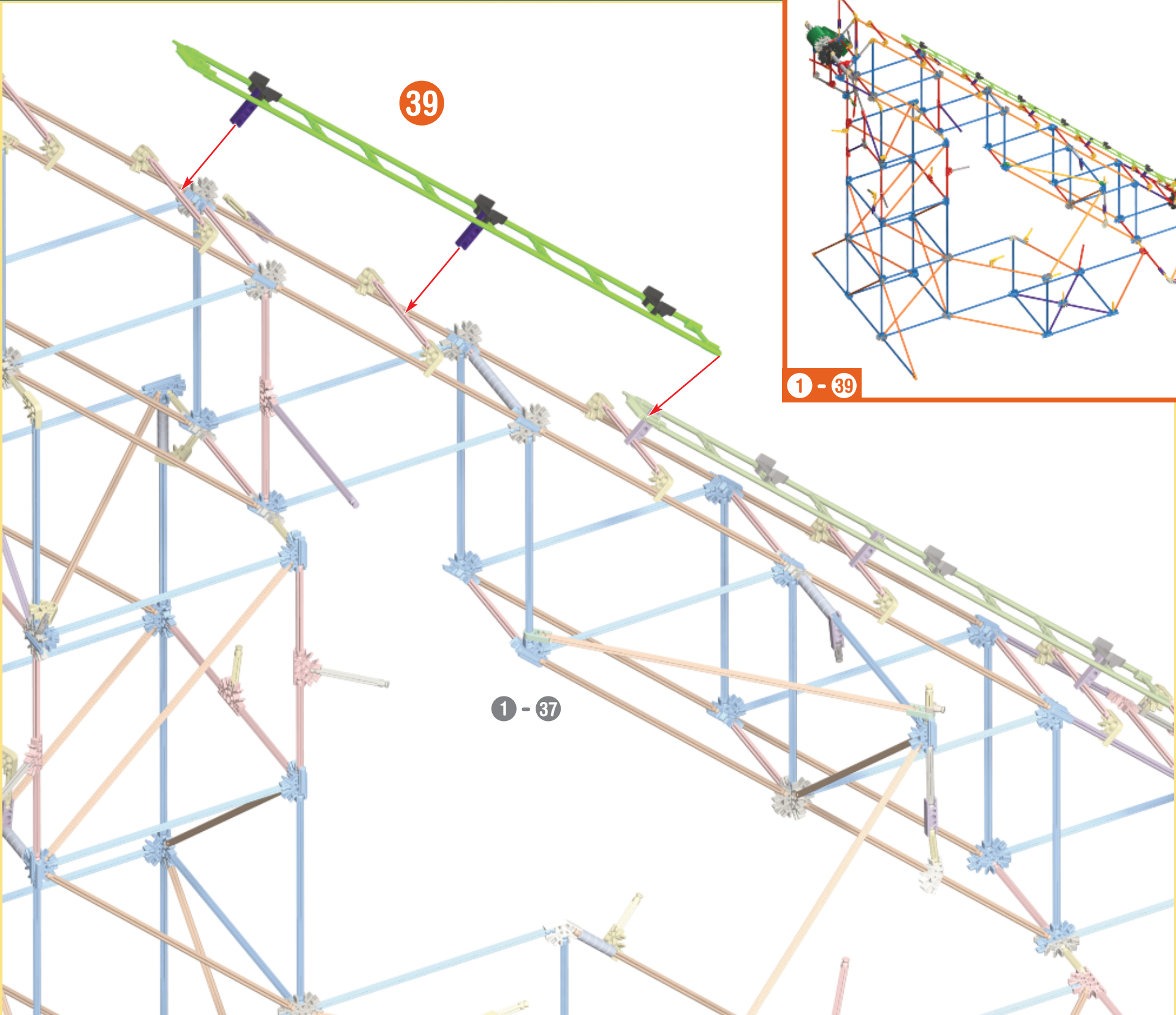
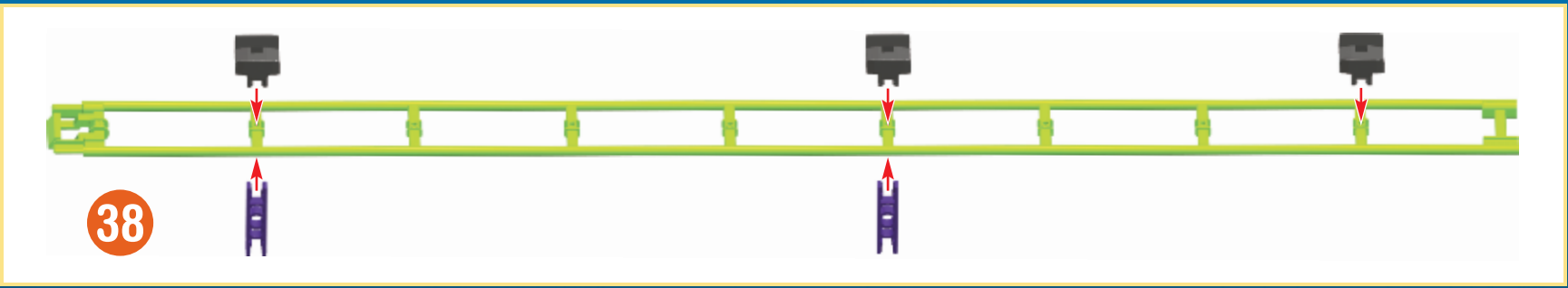

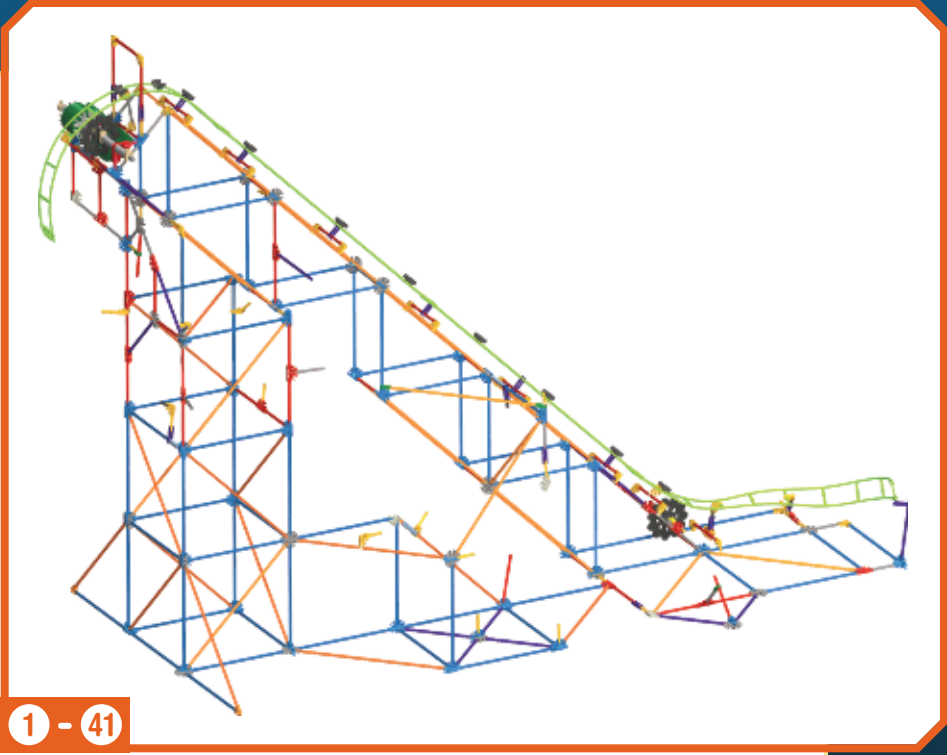
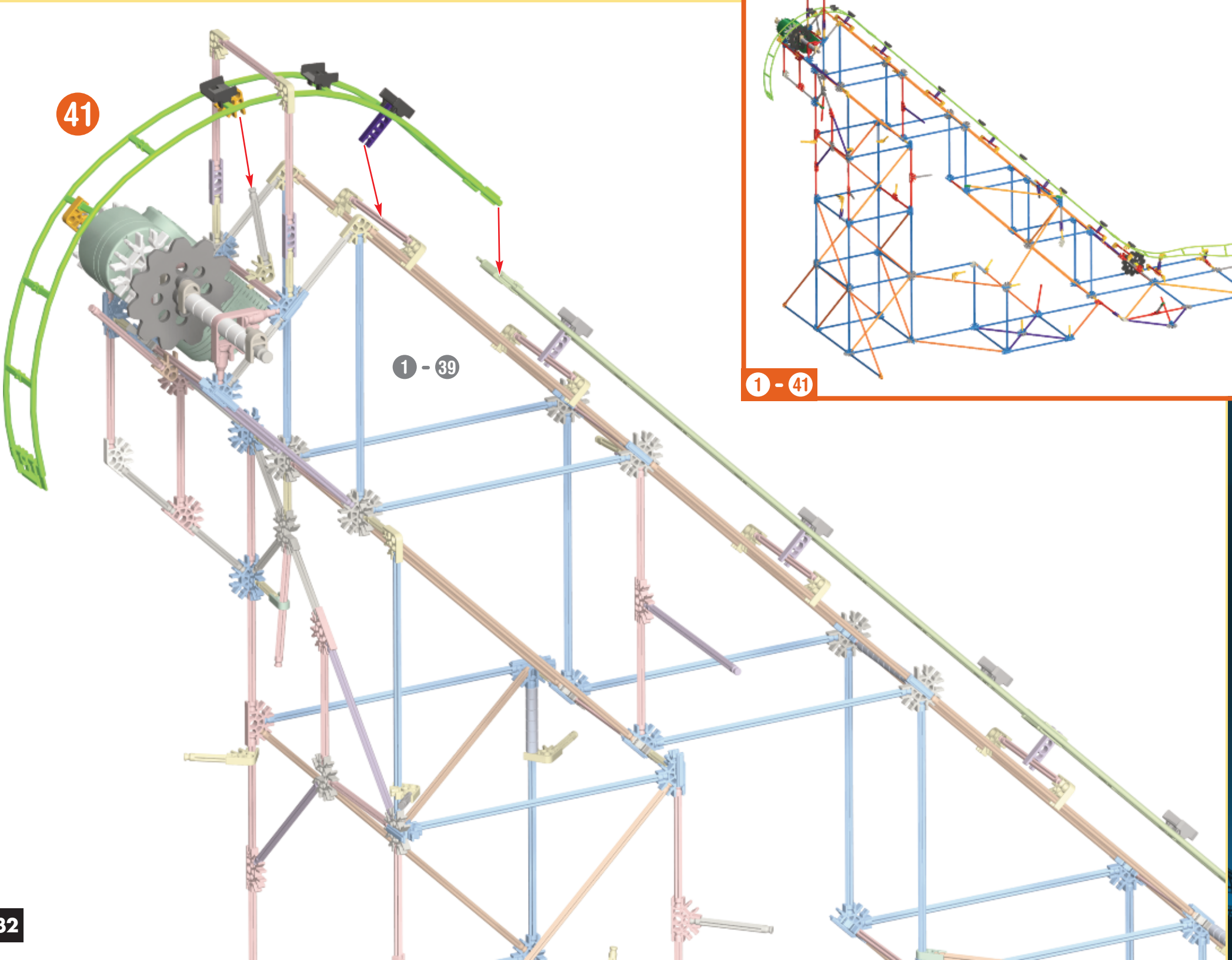
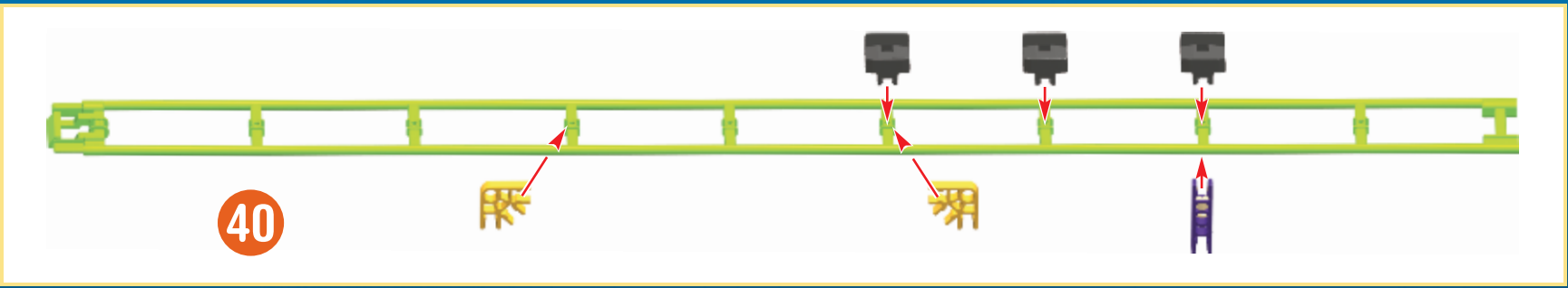



42

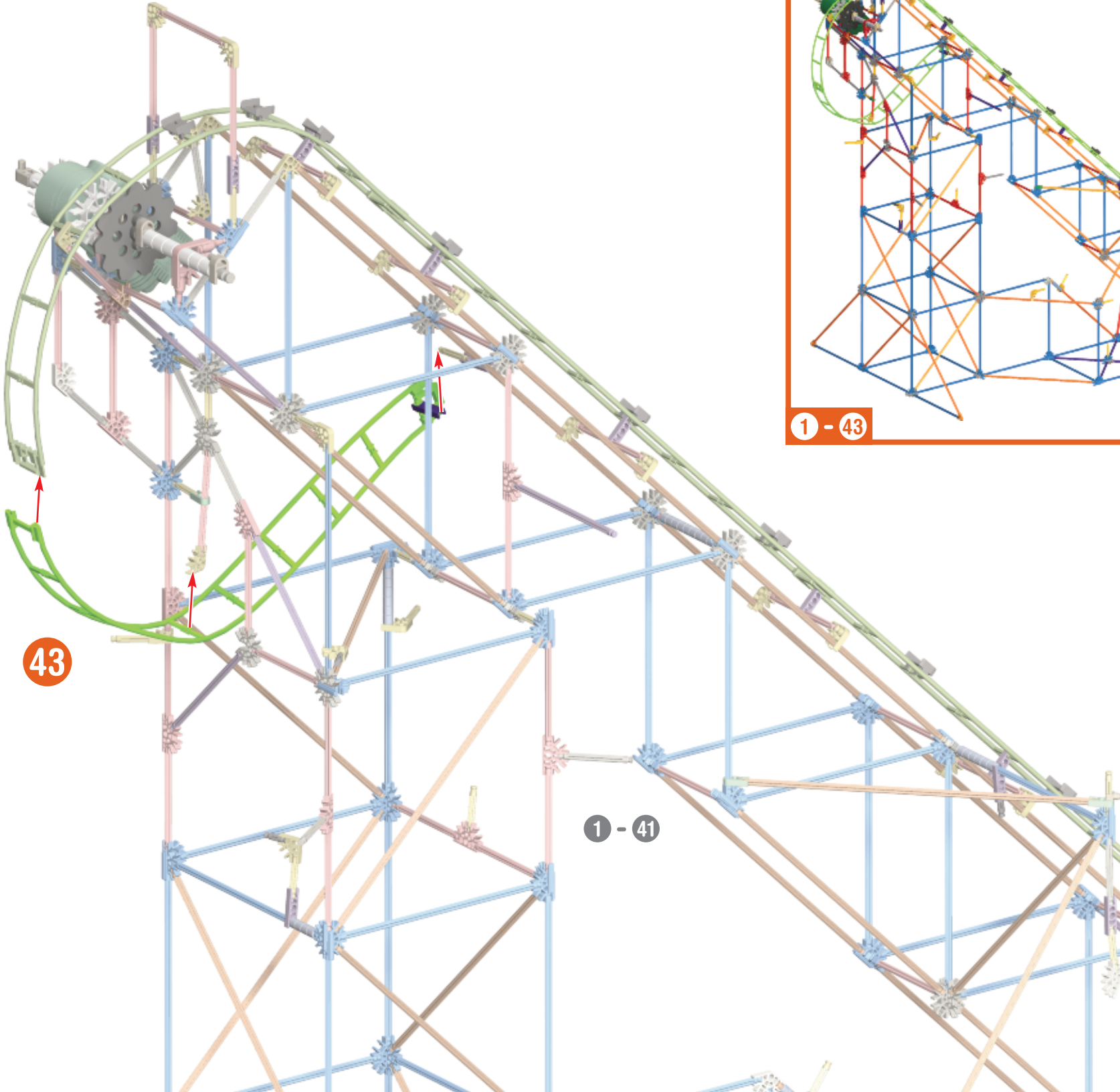

43

1 - 41

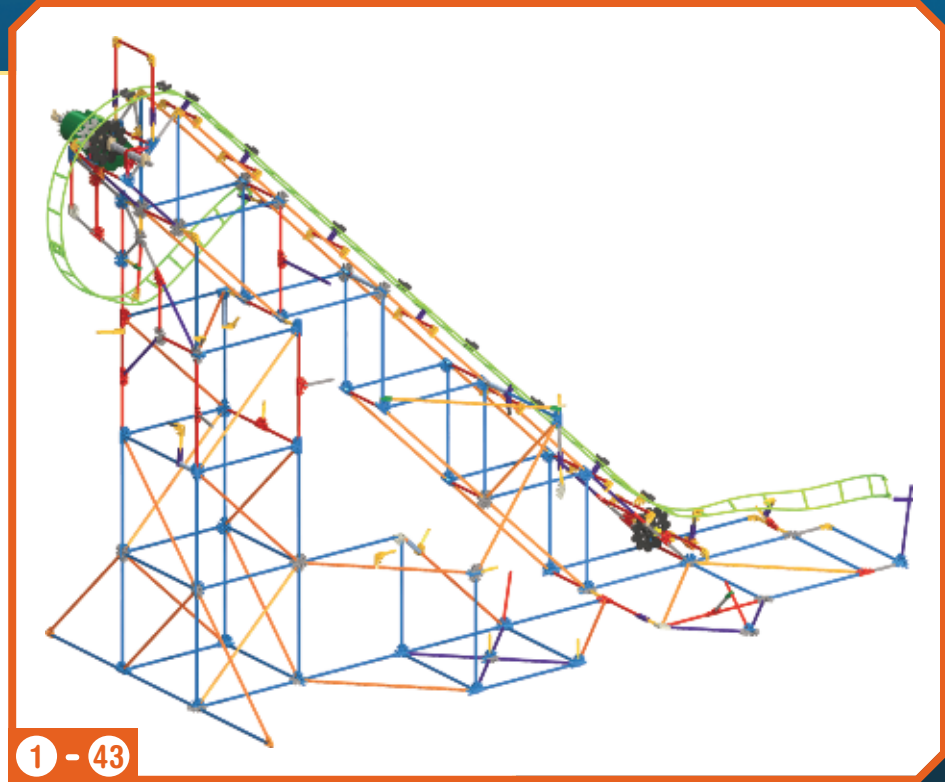

1 - 43





翔

44

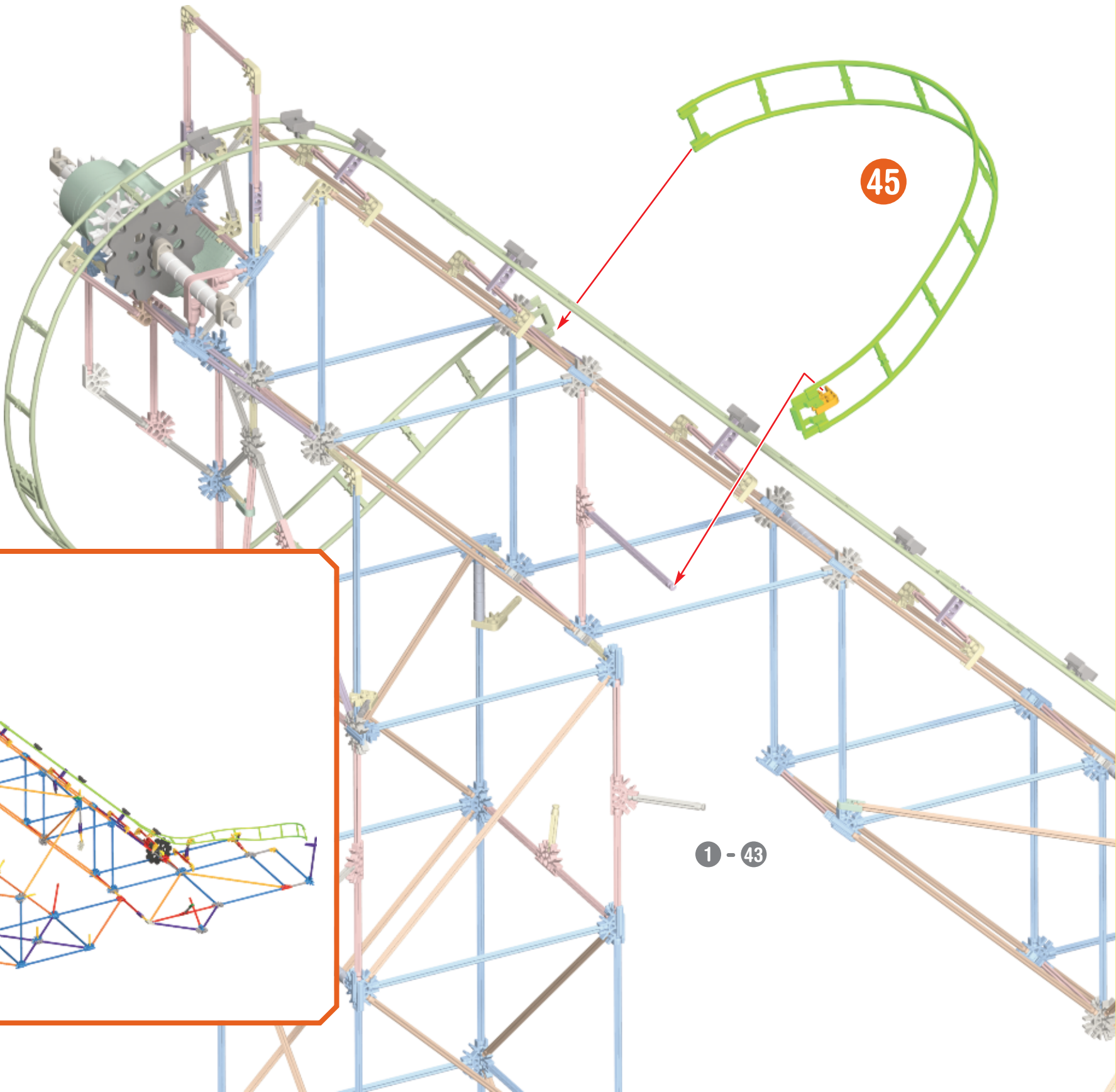

45

1 - 43

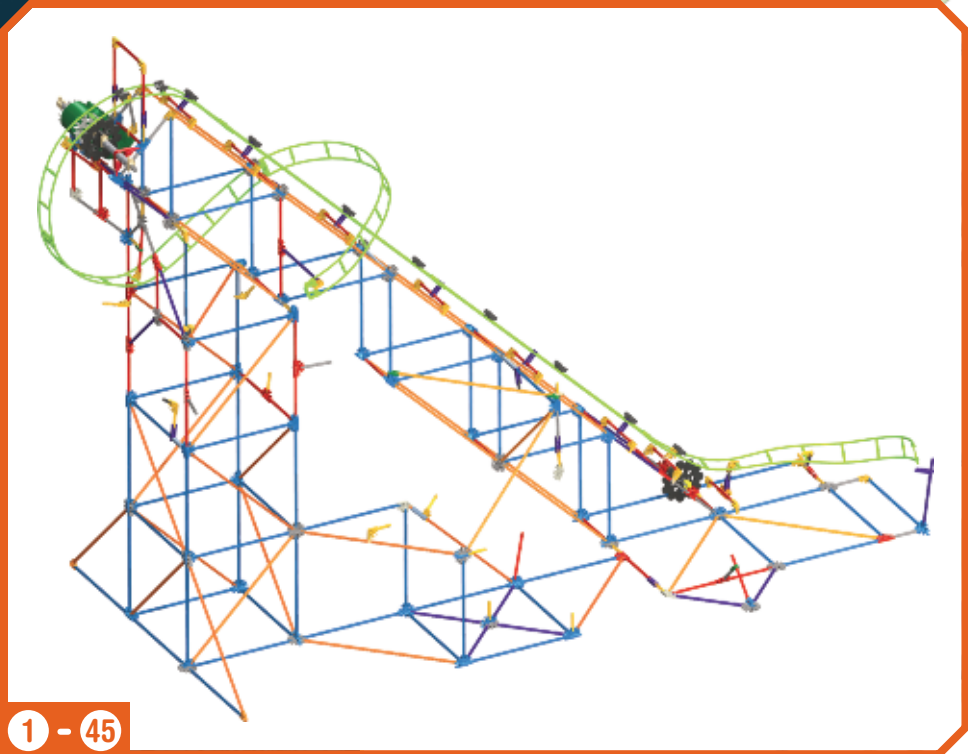

1 - 45

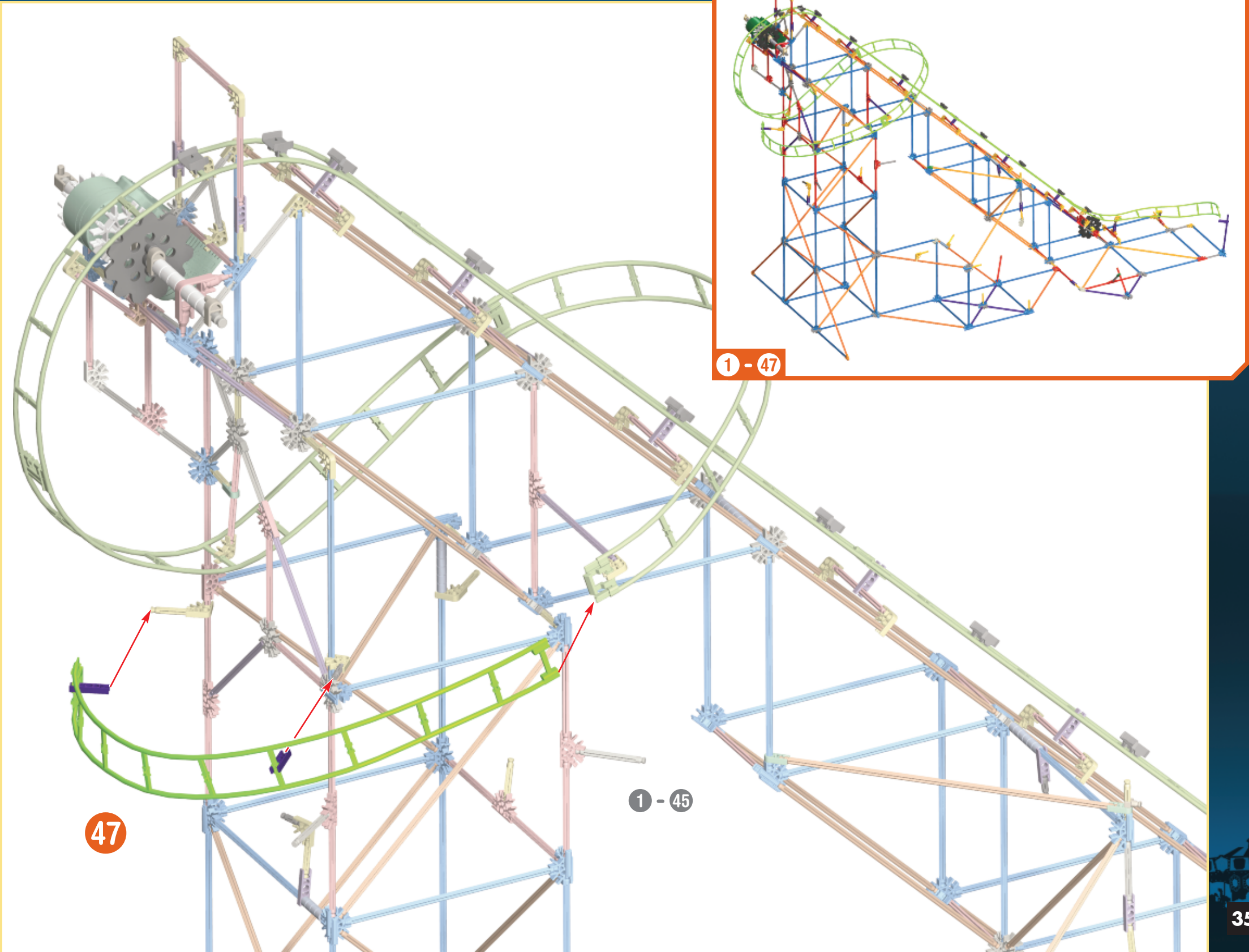
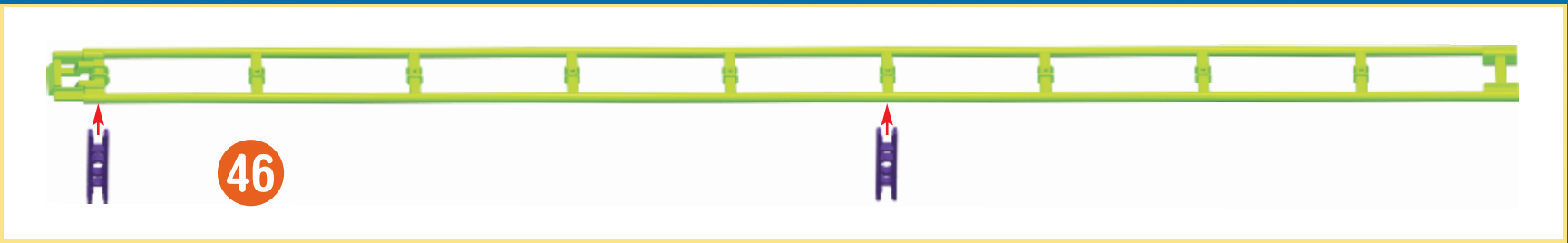

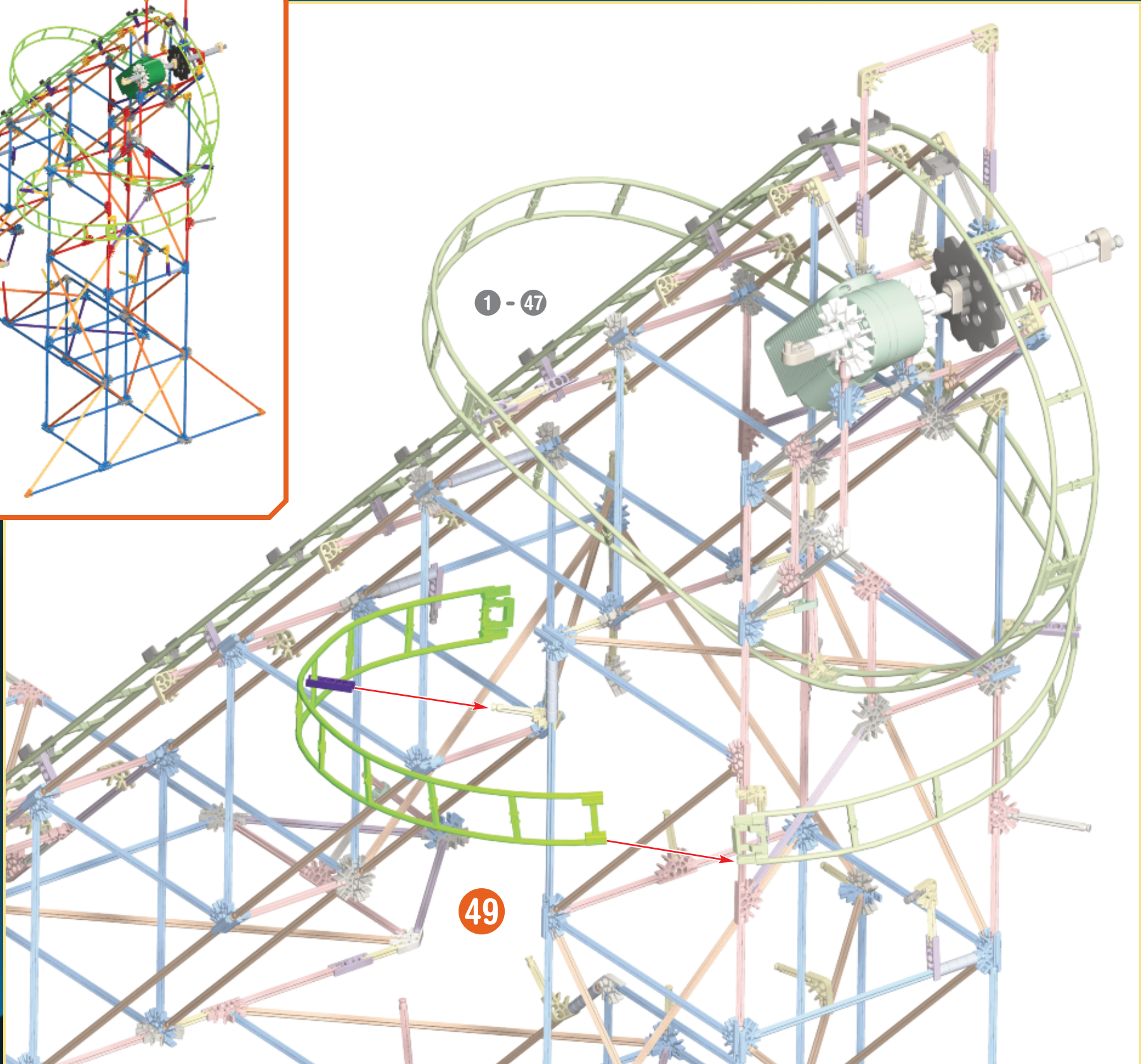
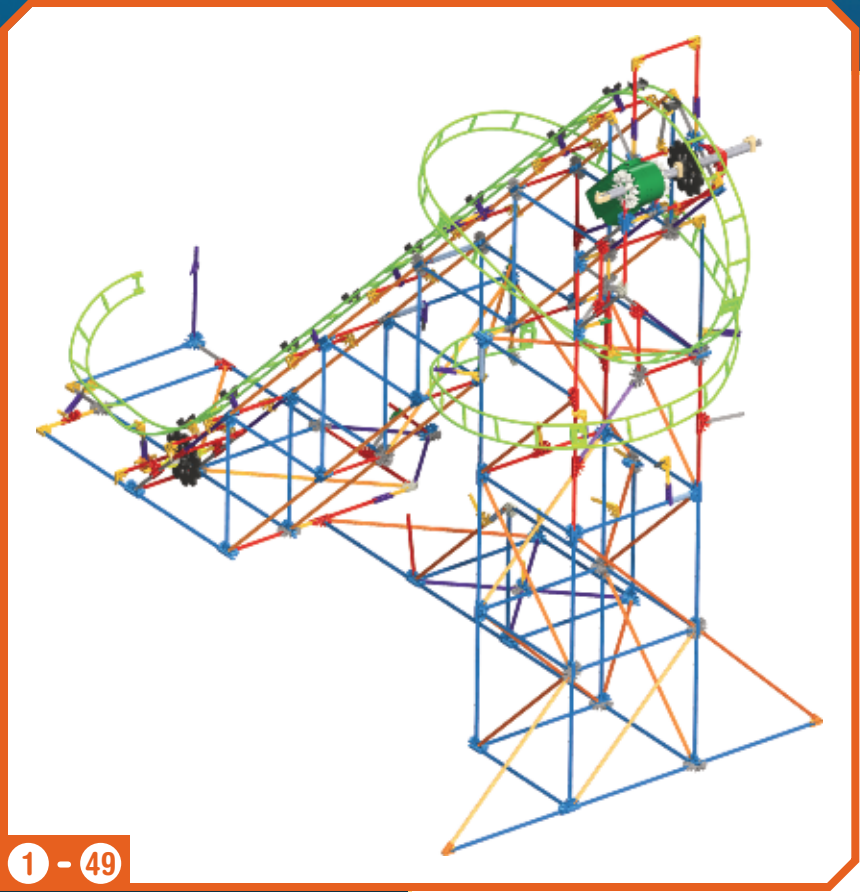
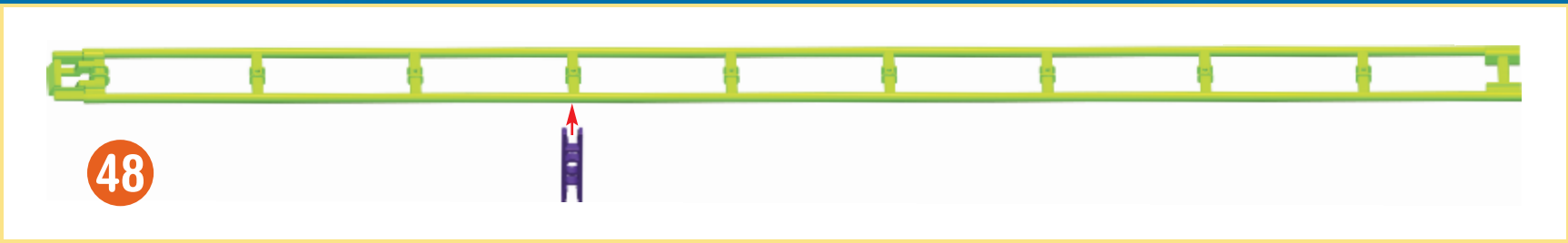

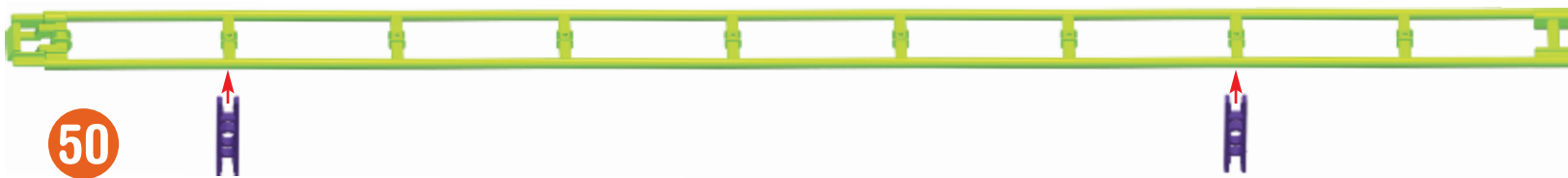

50

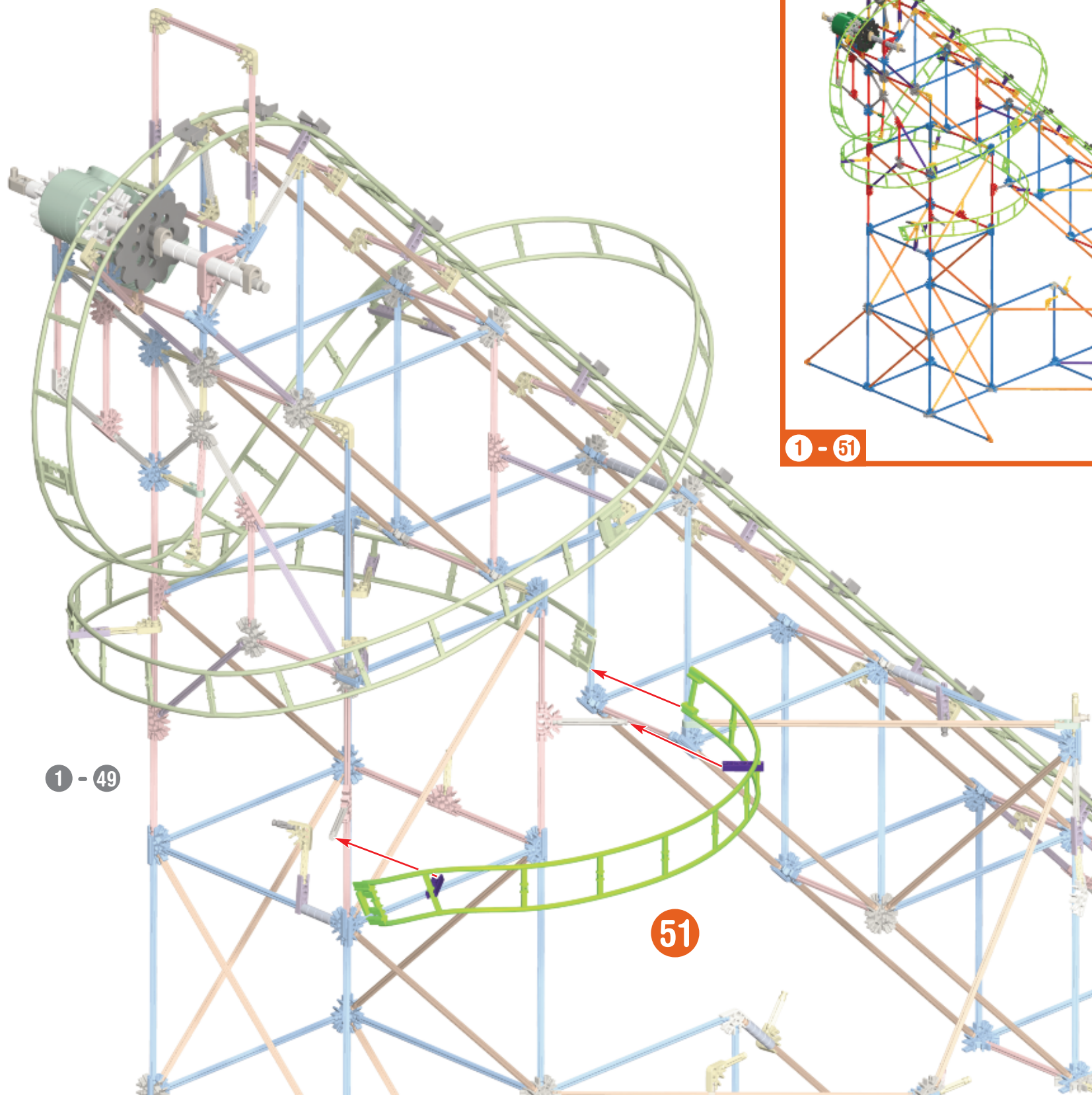

1 - 49

51

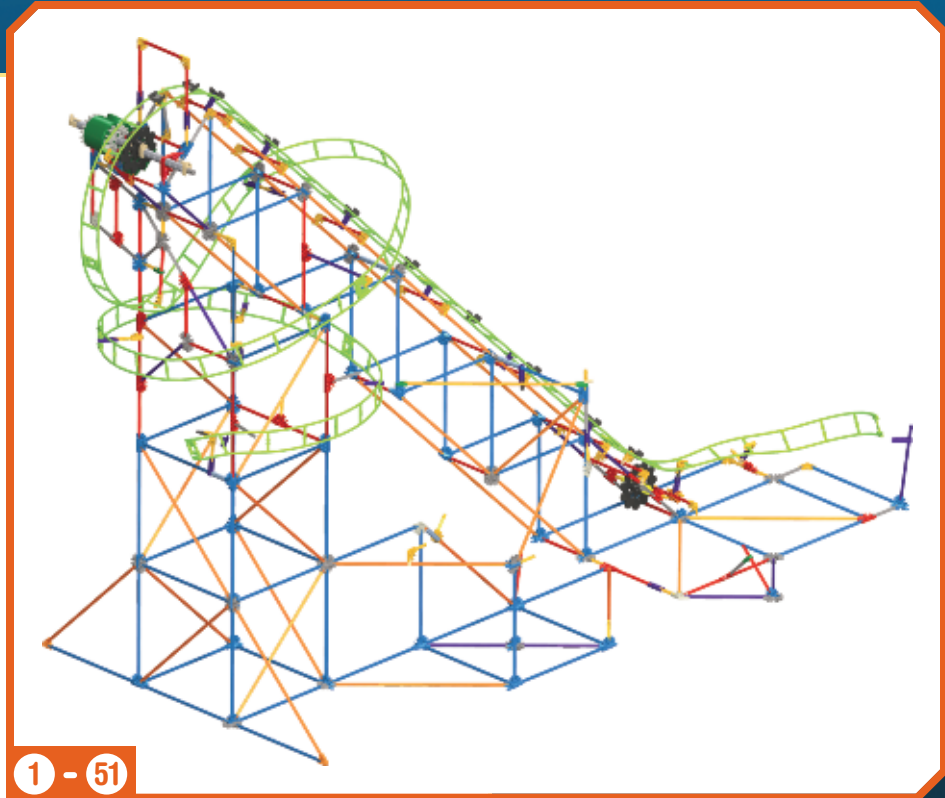

1 - 51

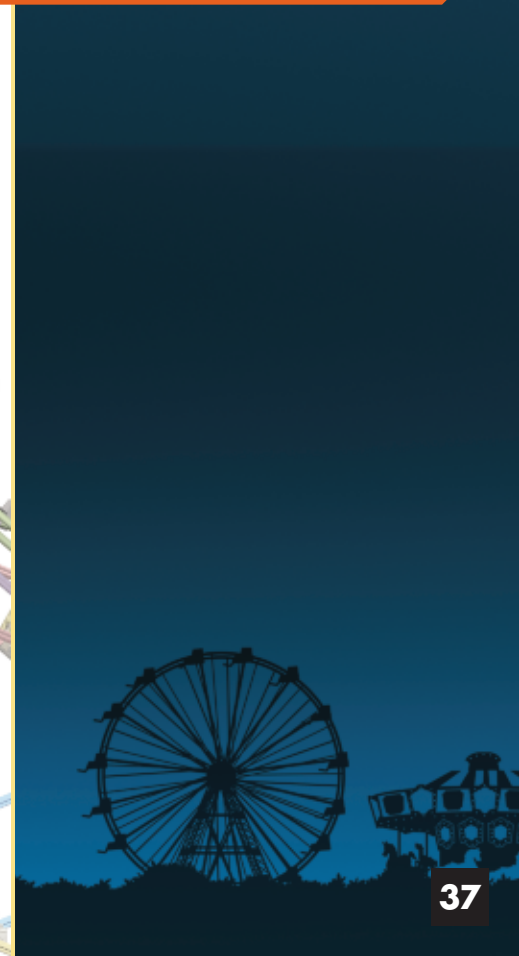

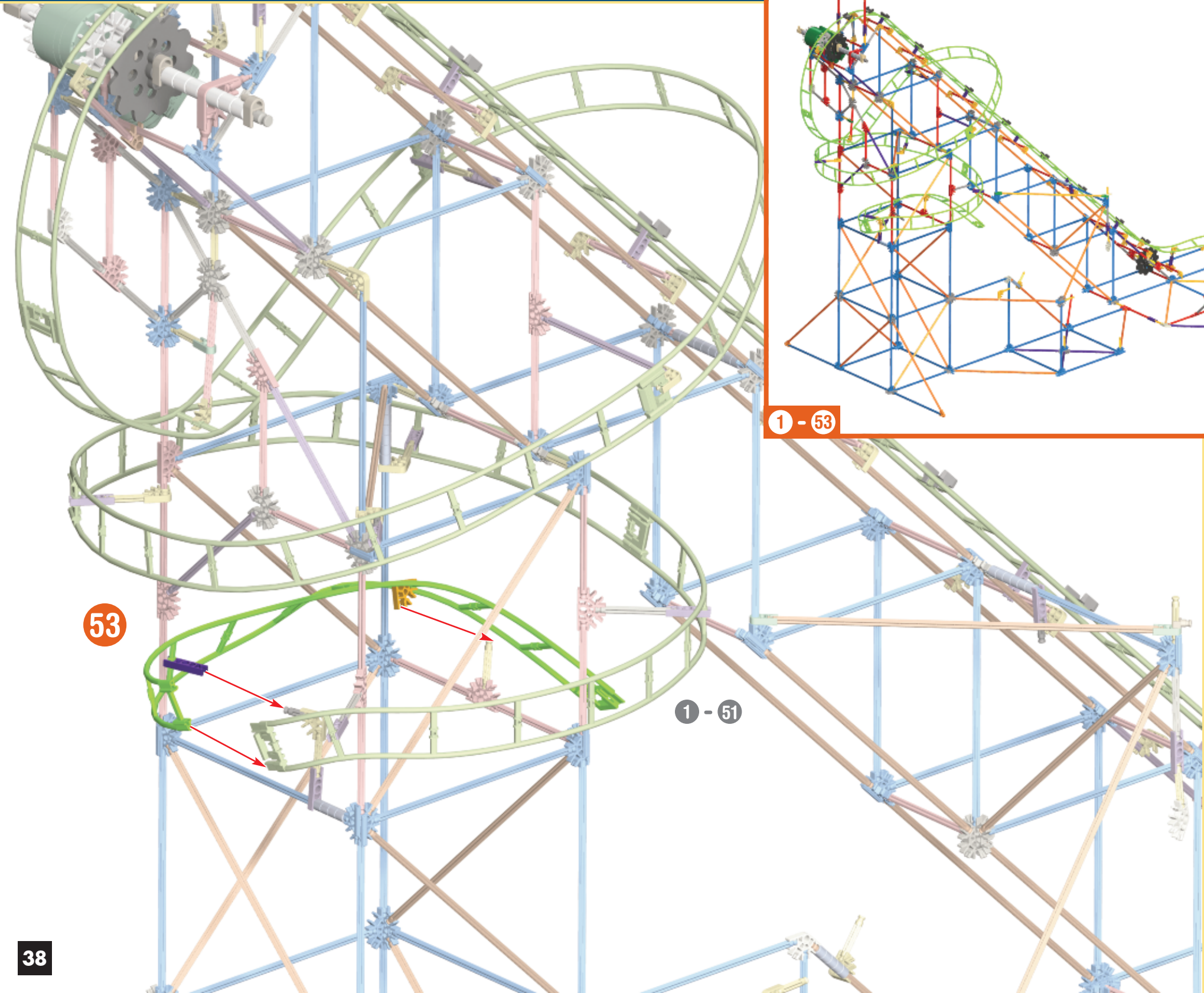
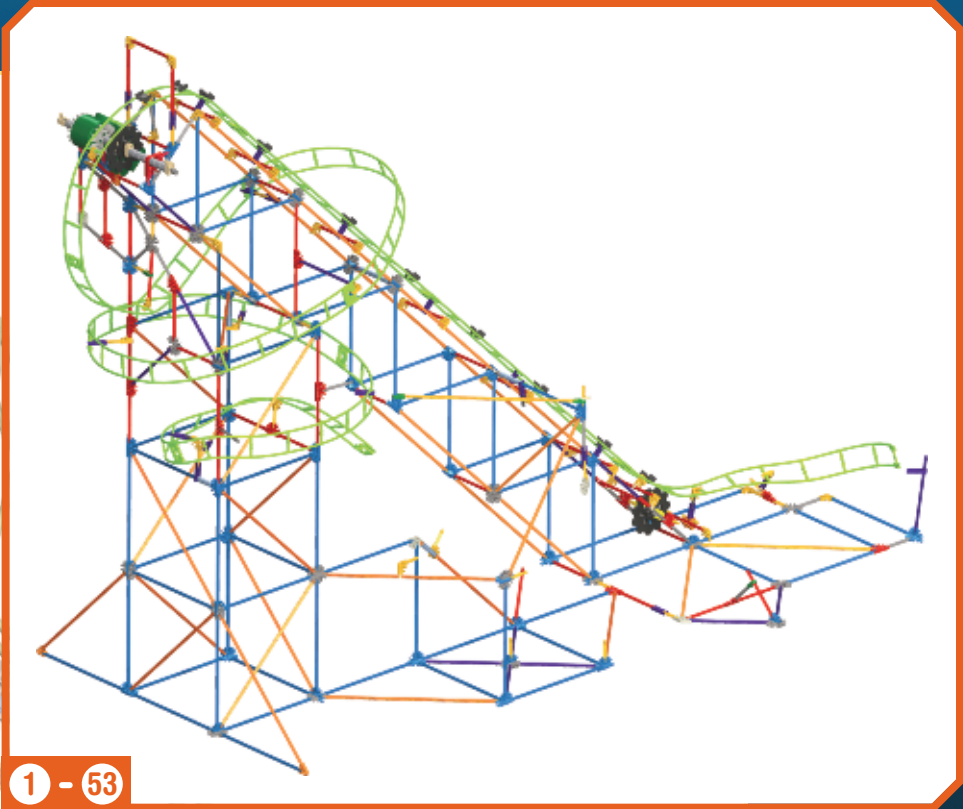
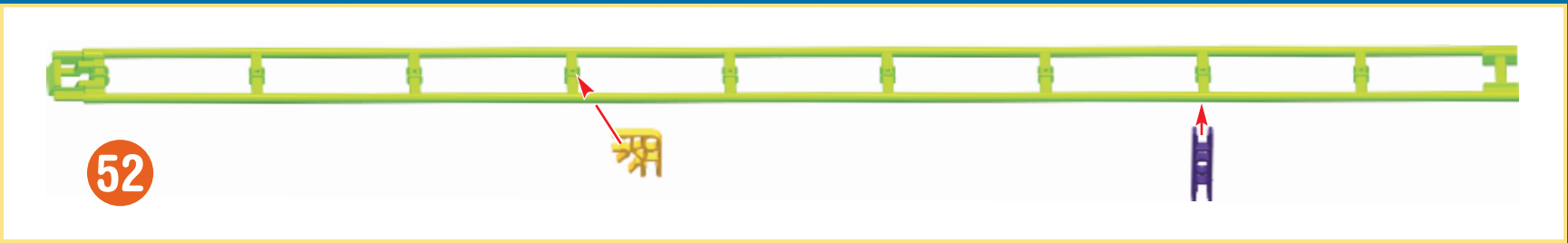



54

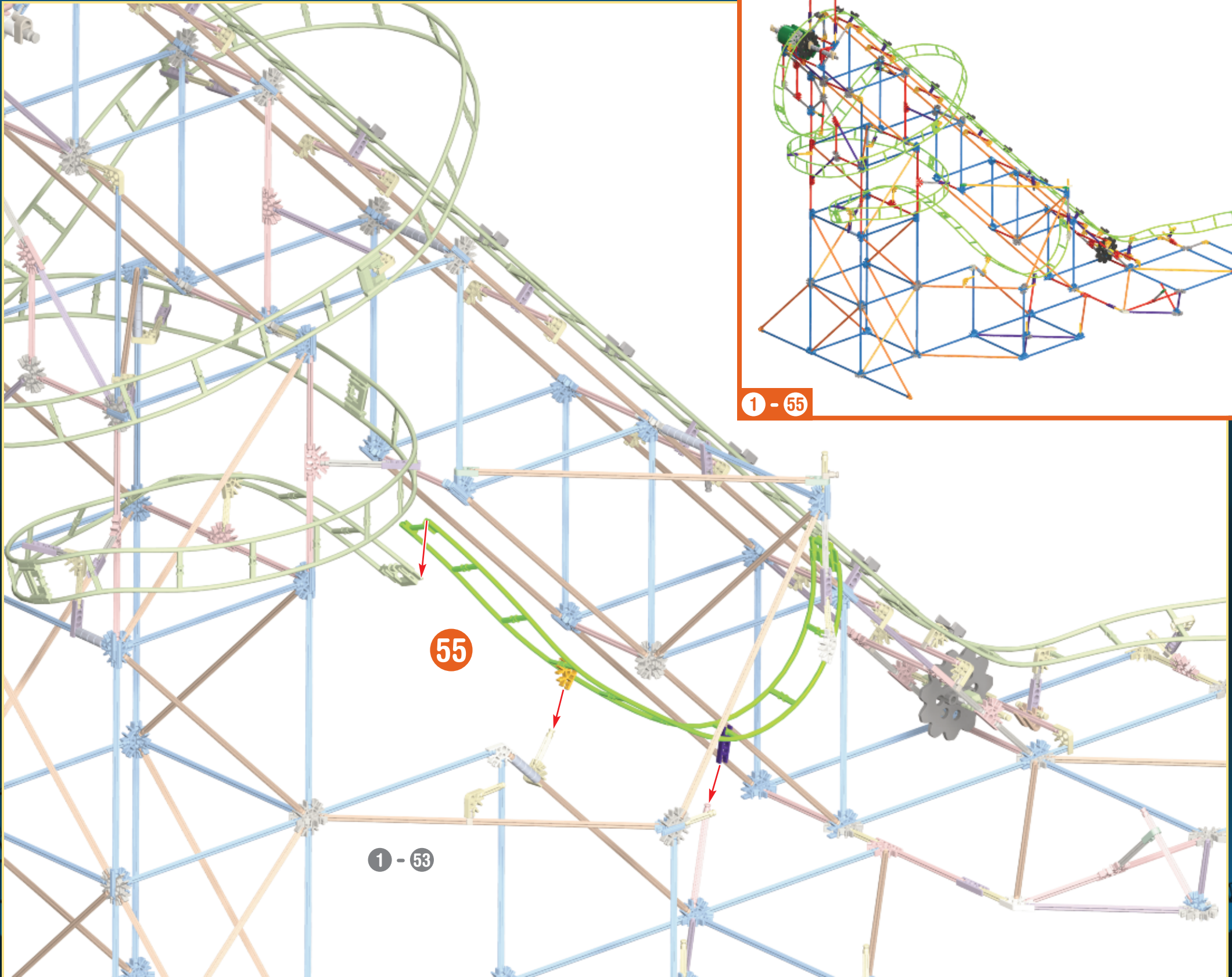

55

1 - 53

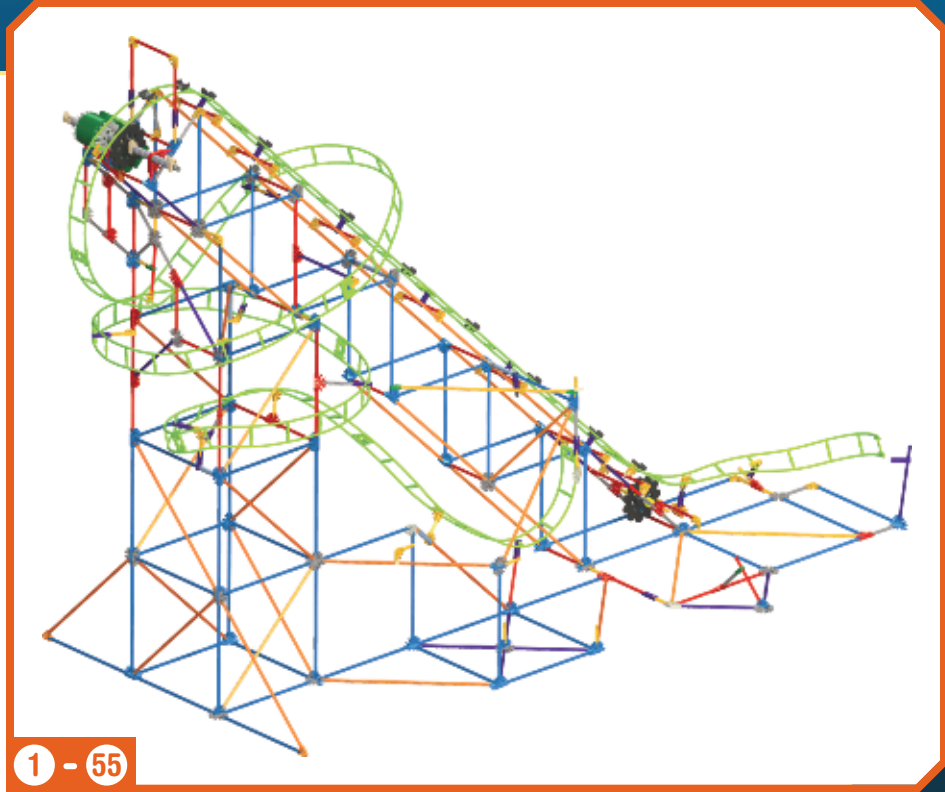

1 - 55

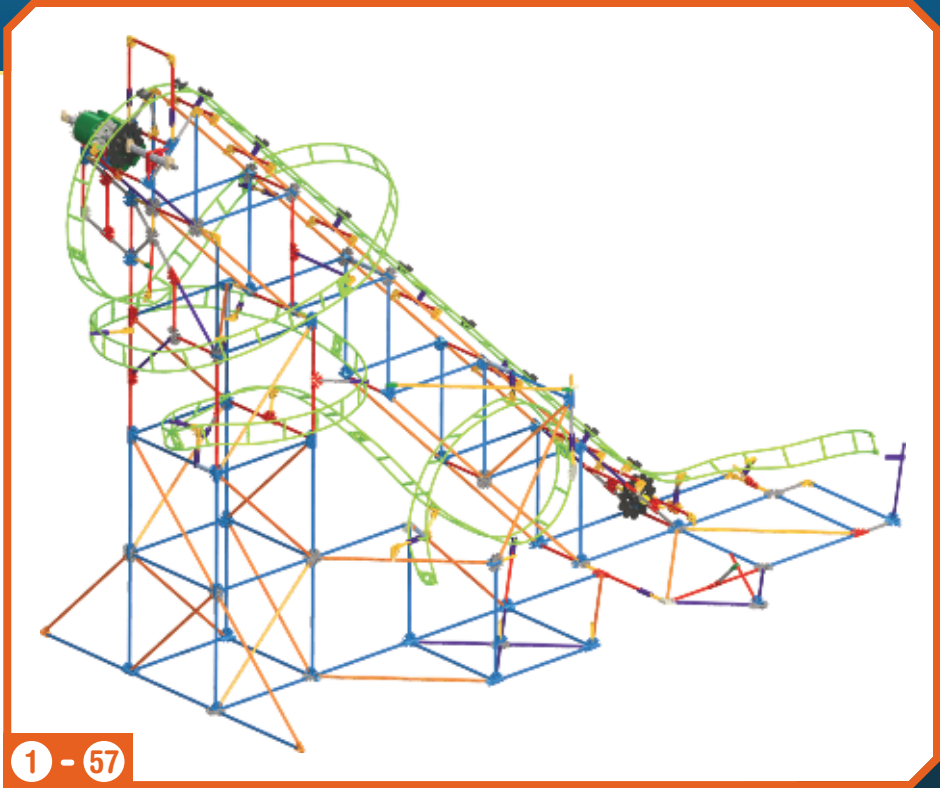
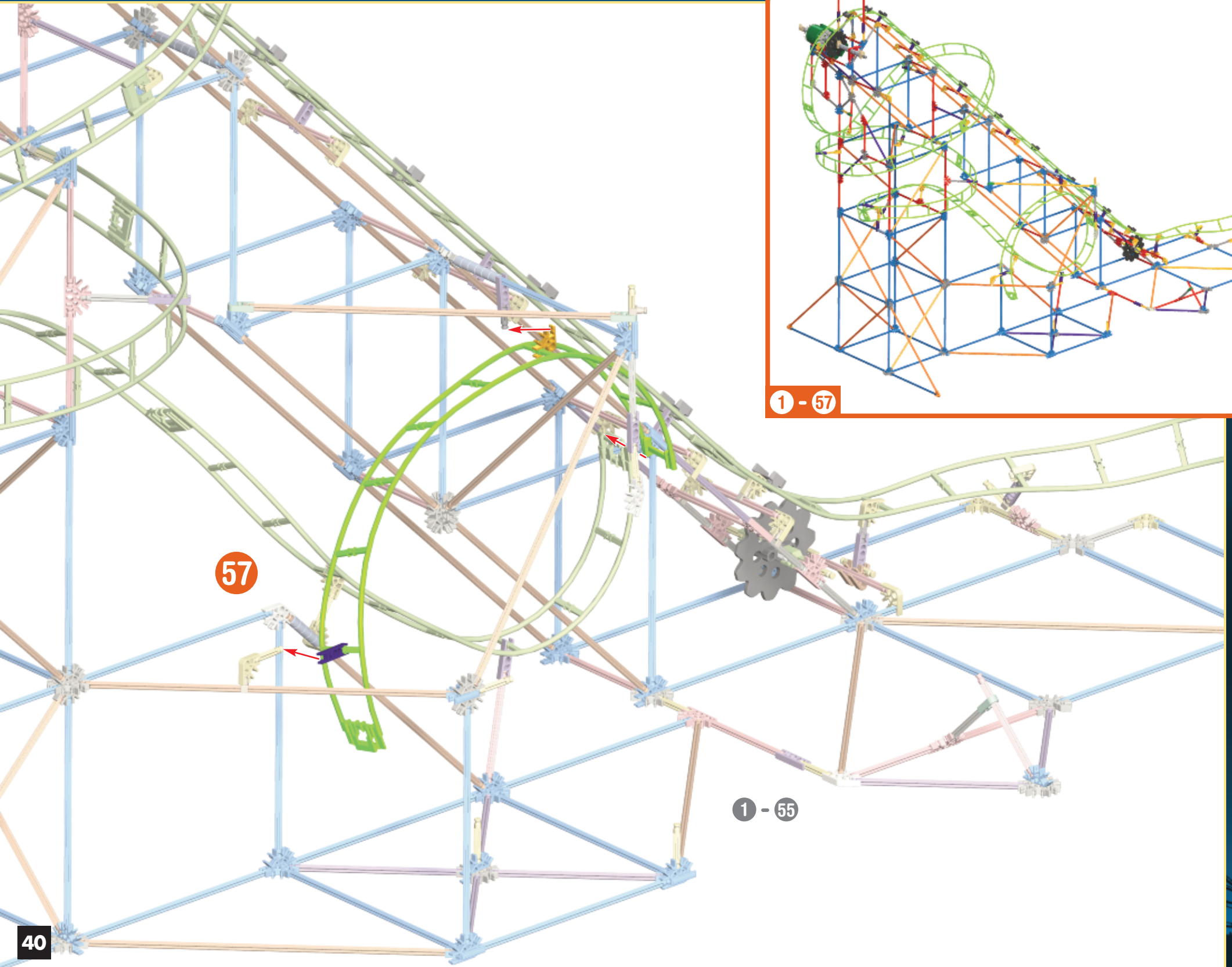
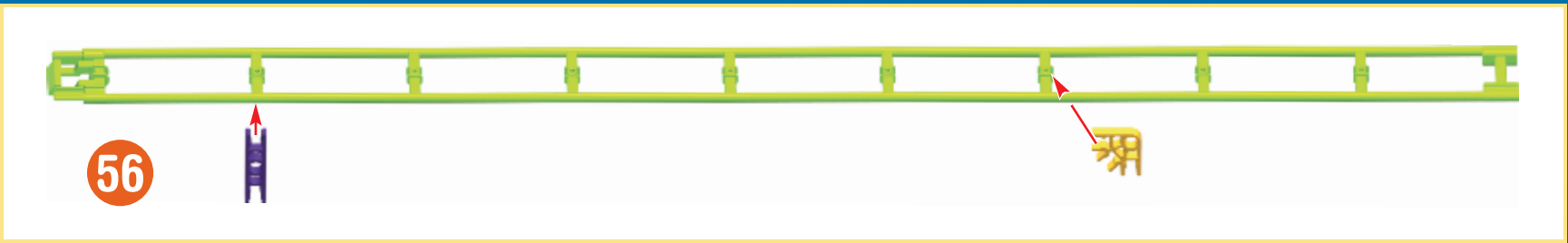

1 - 55



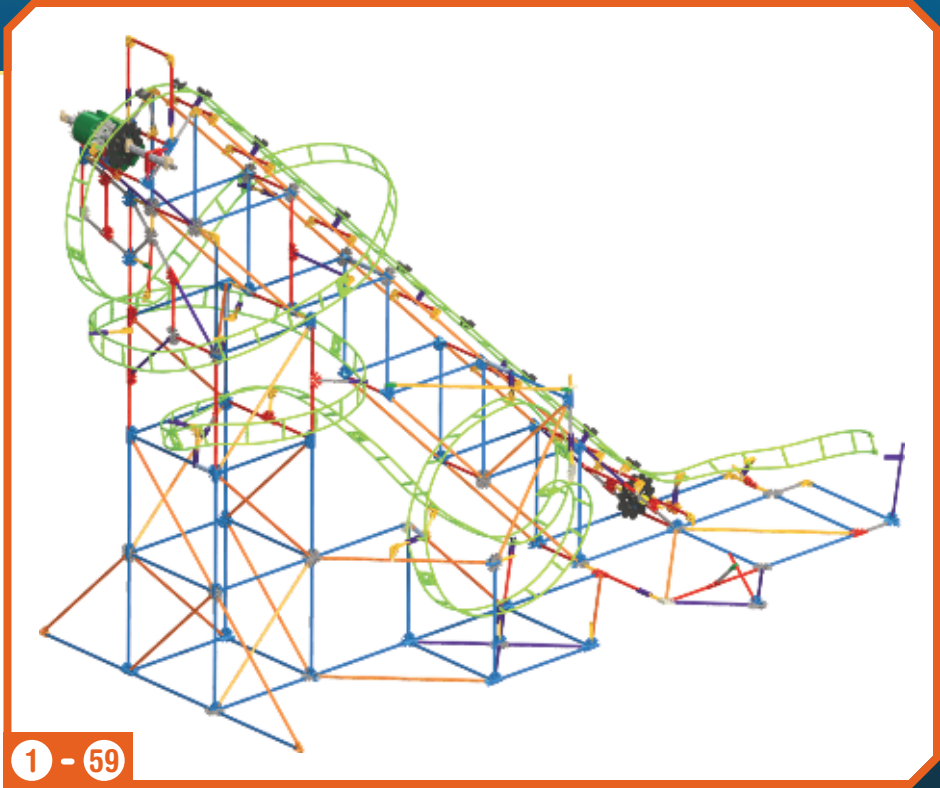
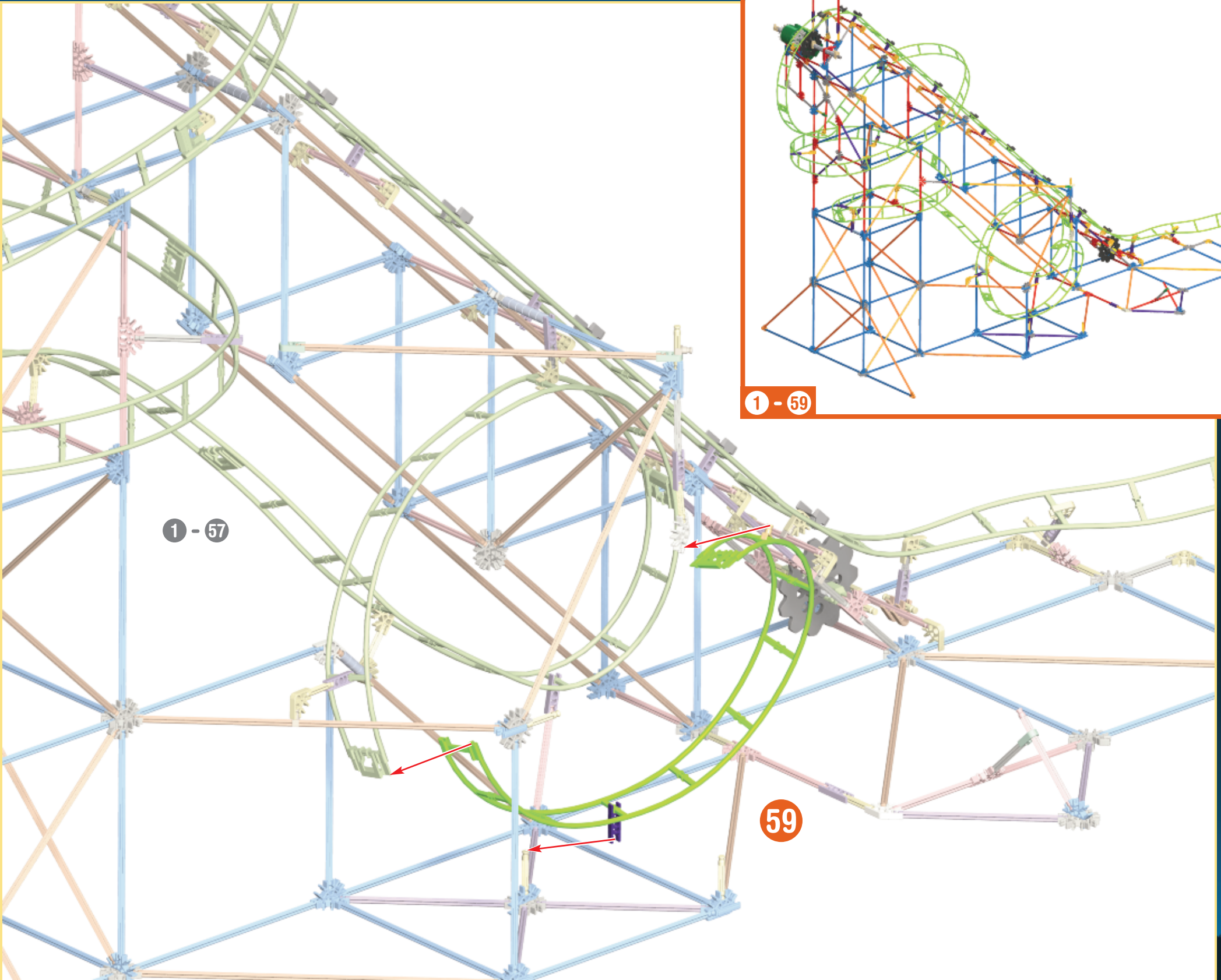
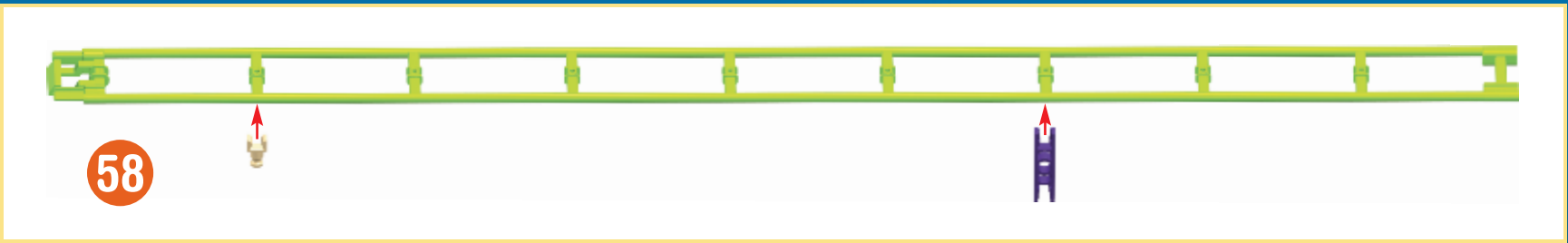

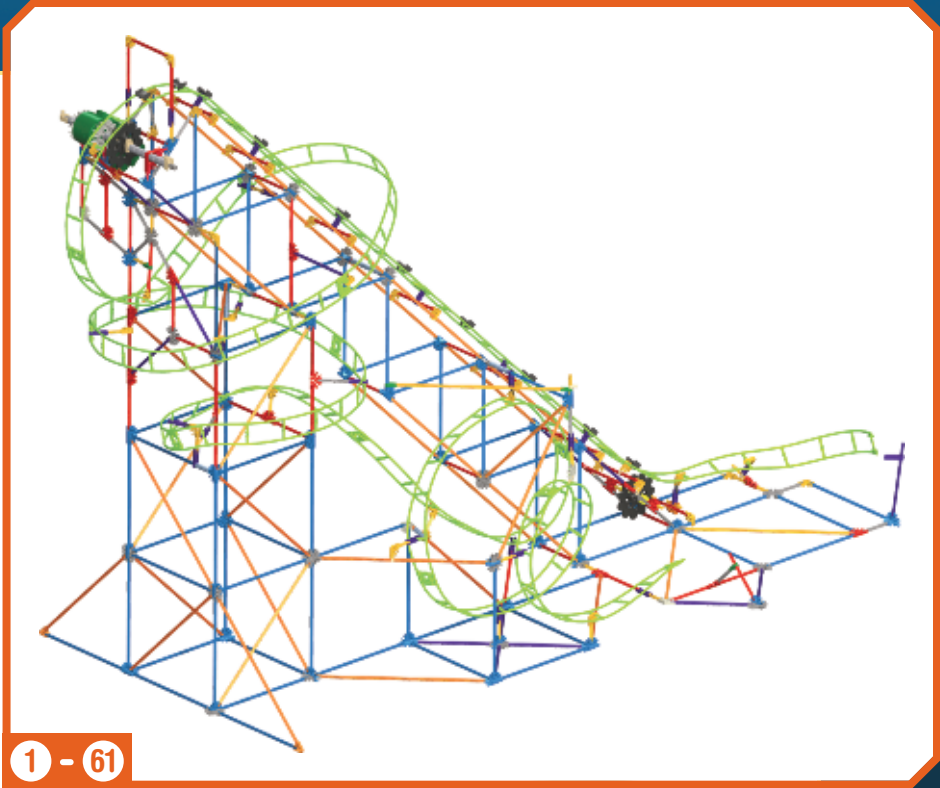
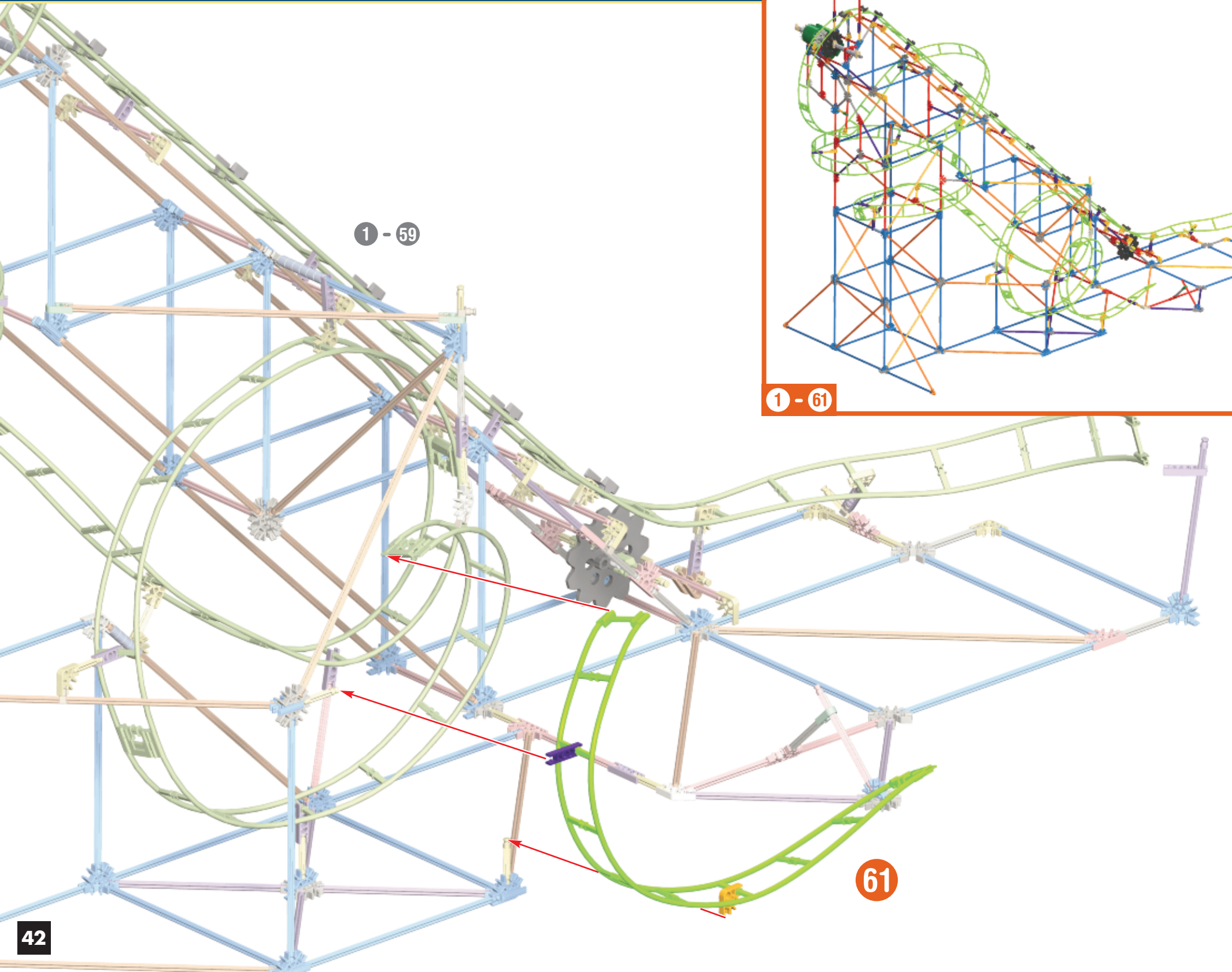
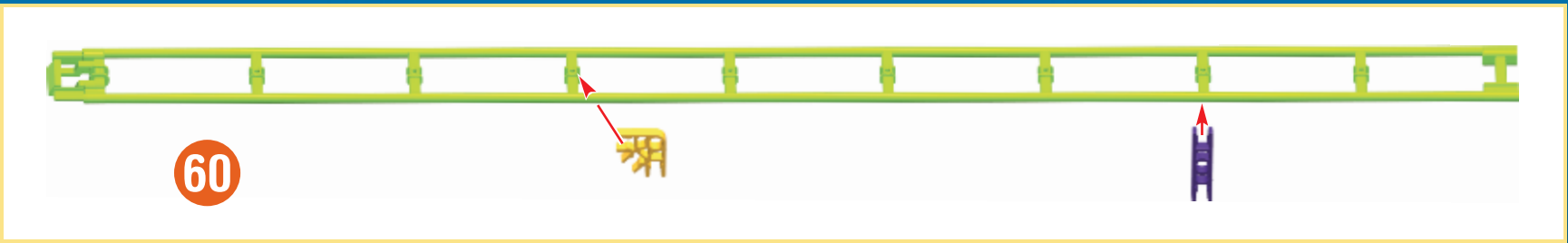

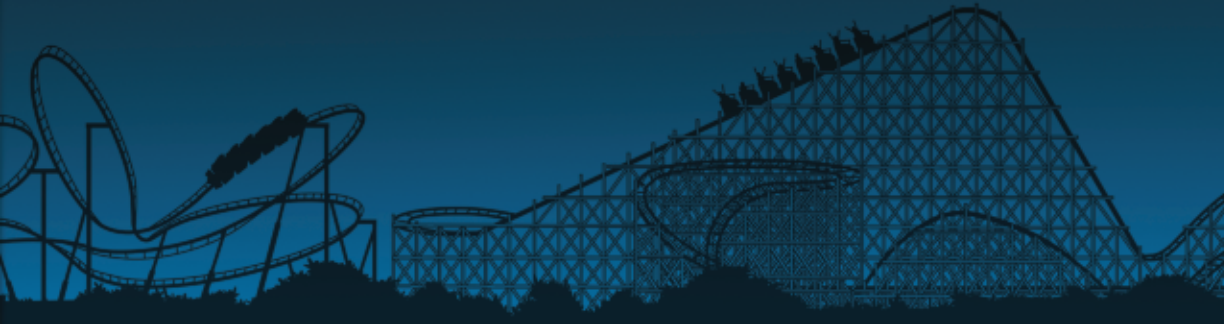
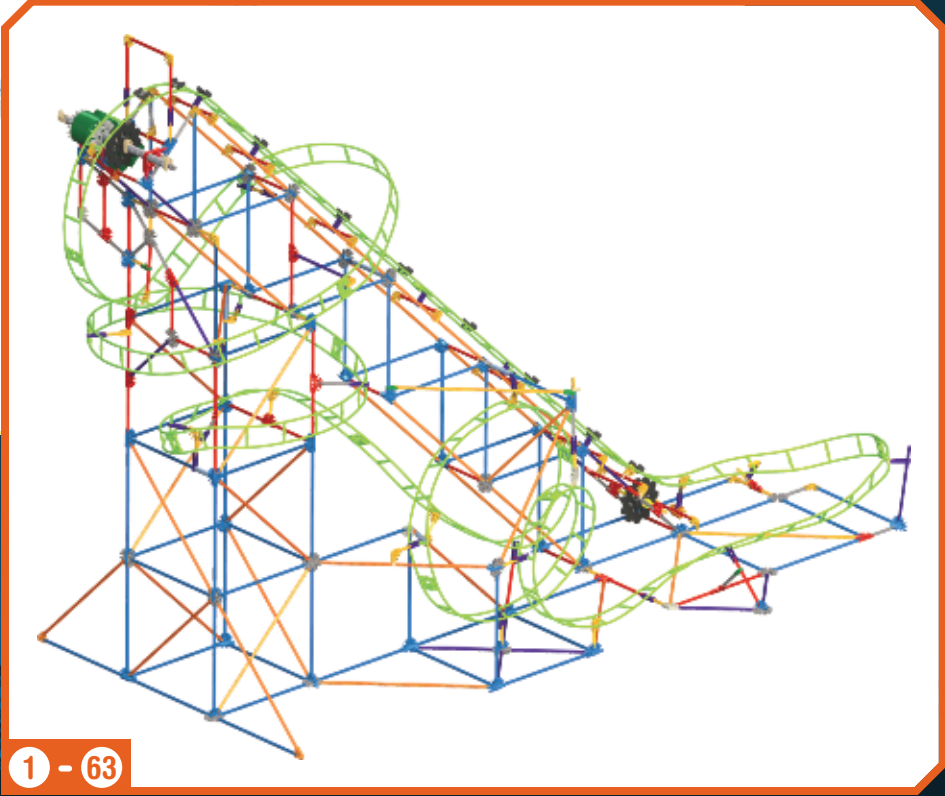
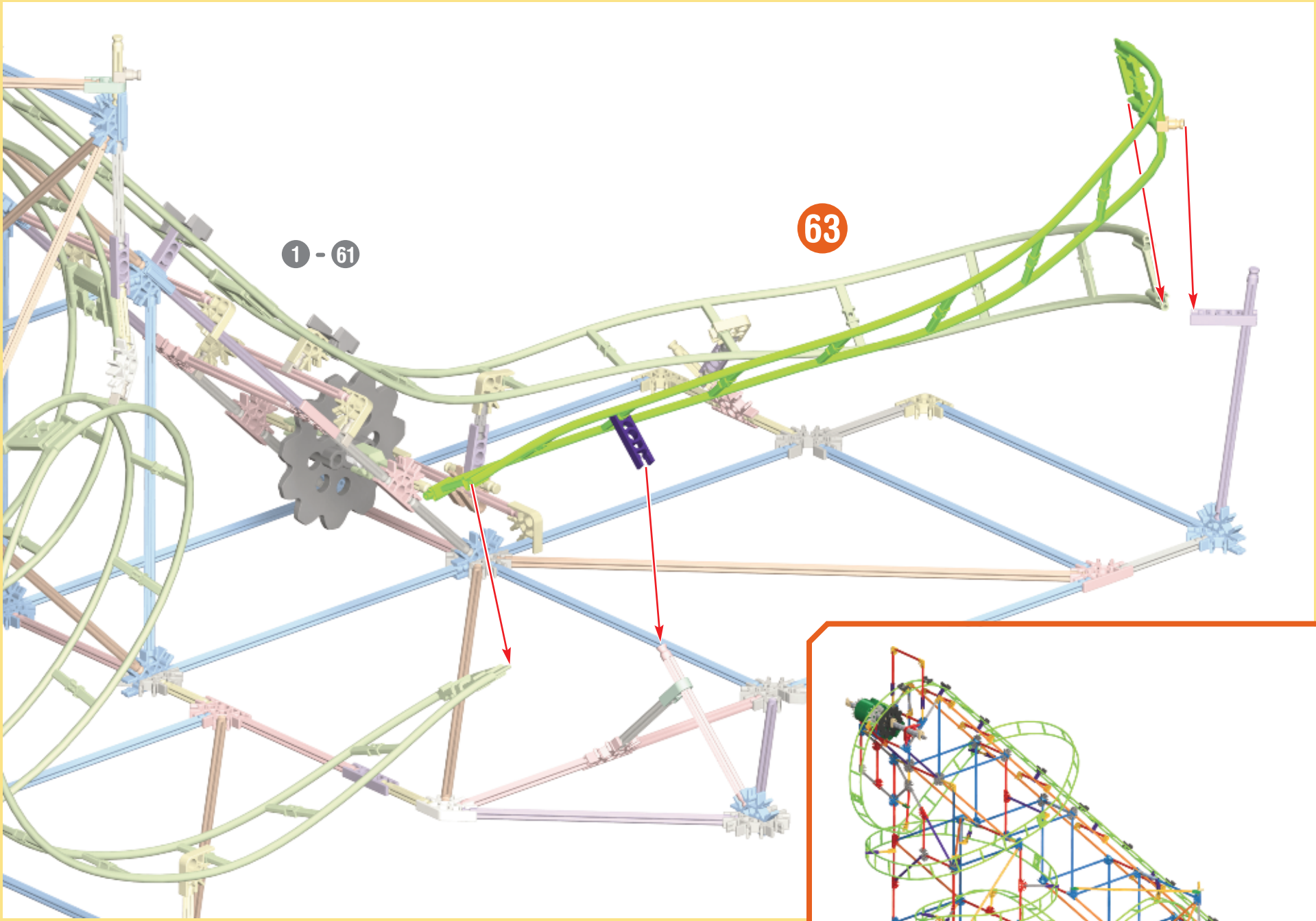
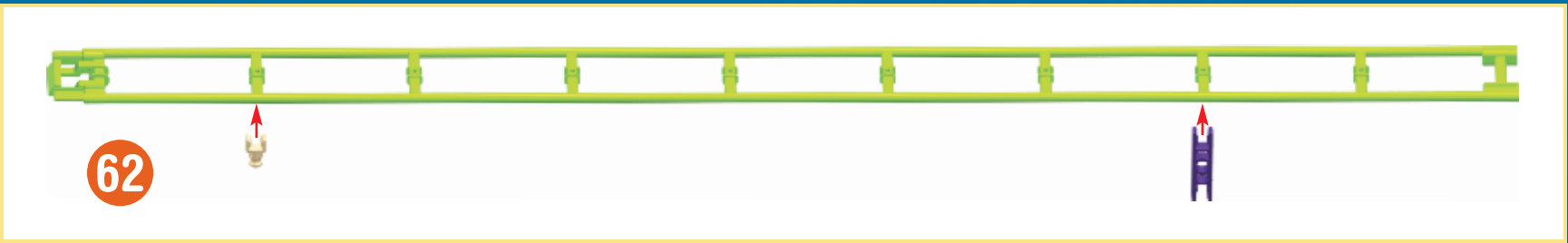



EN IMPORTANT: Attach all the chain links in the same direction.

ES IMPORTANTE: Una los eslabones de la cadena en la misma dirección.

PT IMPORTANTE: Todos os elos da corrente devem estar conectados na mesma direção.



64

x1



65

x16

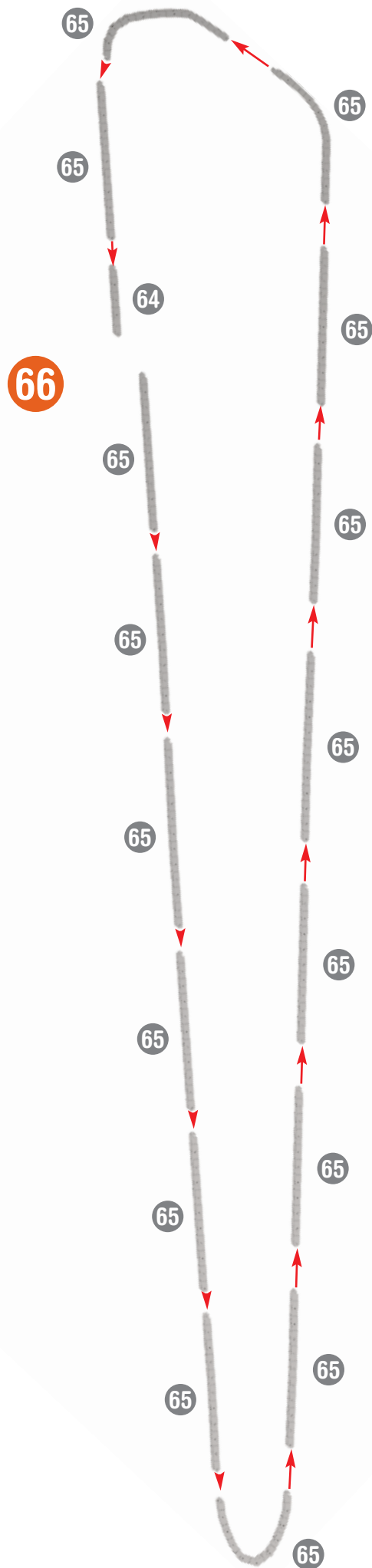

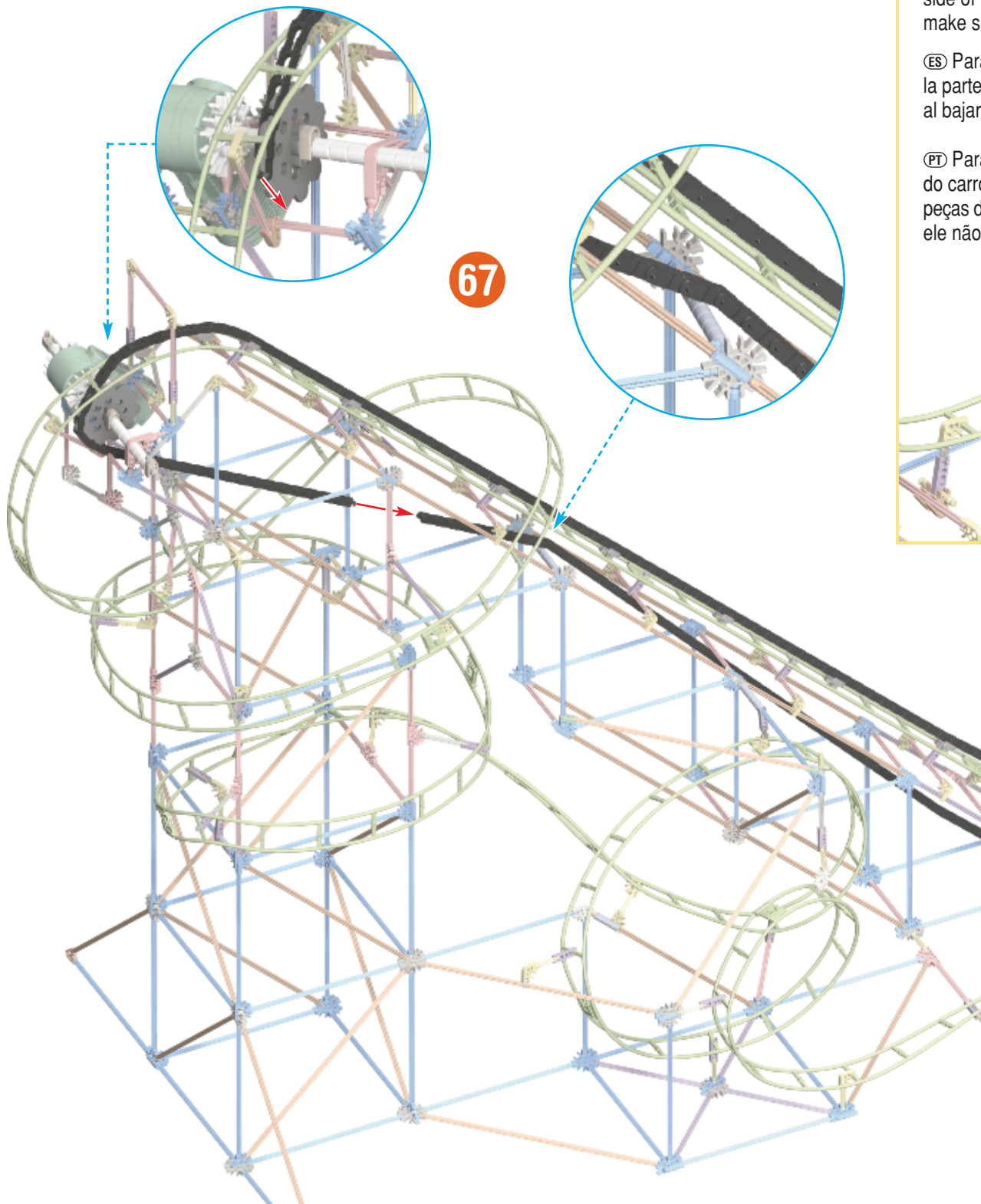

Ⓔ To attach the car, undo a piece of track and then thread the car wheels over the top side of the track. Then join the track pieces together. If the car gets stuck on the way down, make sure it is not hitting any K'NEX parts.

Ⓔ Para colocar el carro, quite una pieza de la vía y embone las ruedas del carro sobre la parte superior de la vía. Luego vuelva a unir las piezas de la vía. Si el carro se atora al bajar, asegúrese de que no esté golpeando ninguna pieza K'NEX.

Ⓔ Para conectar o carro, desmonte uma parte do trilho e faça as rodas do carro passar pelo lado superior do trilho. Em seguida, conecte as peças do trilho. Se o carro ficar preso na descida, certifique-se de que ele não esteja passando por nenhuma peça do K'NEX .

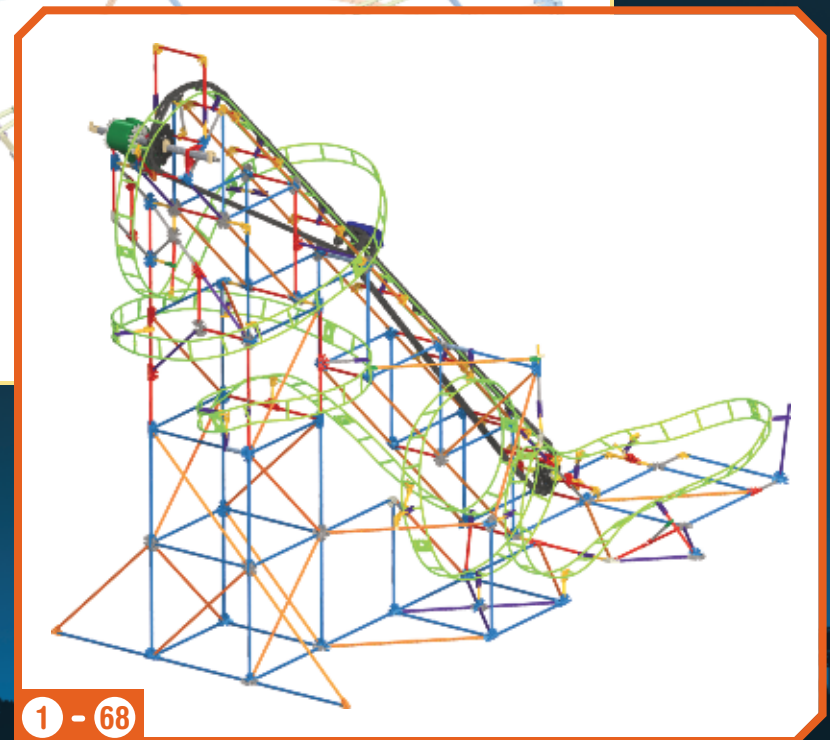
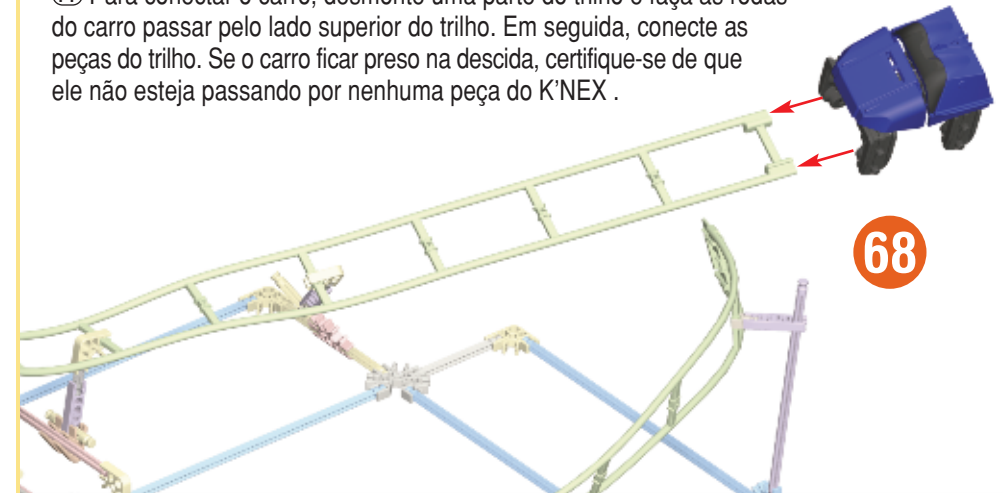

EN TIPS & TROUBLESHOOTING

If the motor is not working properly:

- Check to see if you have fresh batteries and that they are installed correctly.

If a car gets stuck on the track:

- Is the model built correctly?
- Make sure the cars are not hitting any K'NEX parts.
- Are the track pieces connected properly?
- Are the cars attached to the track correctly?
- Adjust the track to eliminate any flat or little bumpy spots on the track.

ES CONSEJOS Y SOLUCIÓN DE PROBLEMAS

Si el motor no funciona de manera adecuada:

- Revise si tiene baterías y si éstas están instaladas correctamente.

Si el carro se atora en la vía:

- ¿El modelo está armado de forma correcta?
- Asegúrese de que los carros no golpeen ninguna pieza K'NEX.
- ¿Las vías están bien ensambladas?
- ¿Los carros están bien montados sobre la vía?
- Ajuste la vía para eliminar cualquier punto plano o desnivelado.

PT SUGESTÕES E RESOLUÇÃO DE PROBLEMAS

Se o motor não estiver funcionando adequadamente:

- Verifique se as pilhas estão novas e se elas foram colocadas corretamente.

Se um carro ficar preso no trilho:

- O modelo foi montado corretamente?
- Certifique-se de que os carros não estejam ficando presos em nenhuma parte do K'NEX.
- Os trilhos estão conectados adequadamente?
- Os carros estão conectados ao trilho adequadamente?
- Ajuste o trilho para eliminar quaisquer lugares retos ou irregulares no trilho.

TEMPEST TWISTER™

Building Idea

Bonus instructions at
www.knex.com/thrill-rides

Ideas de armado

Instrucciones adicionales en
www.knex.com/thrill-rides

Ideias para montagem

Instruções extras
www.knex.com/thrill-rides

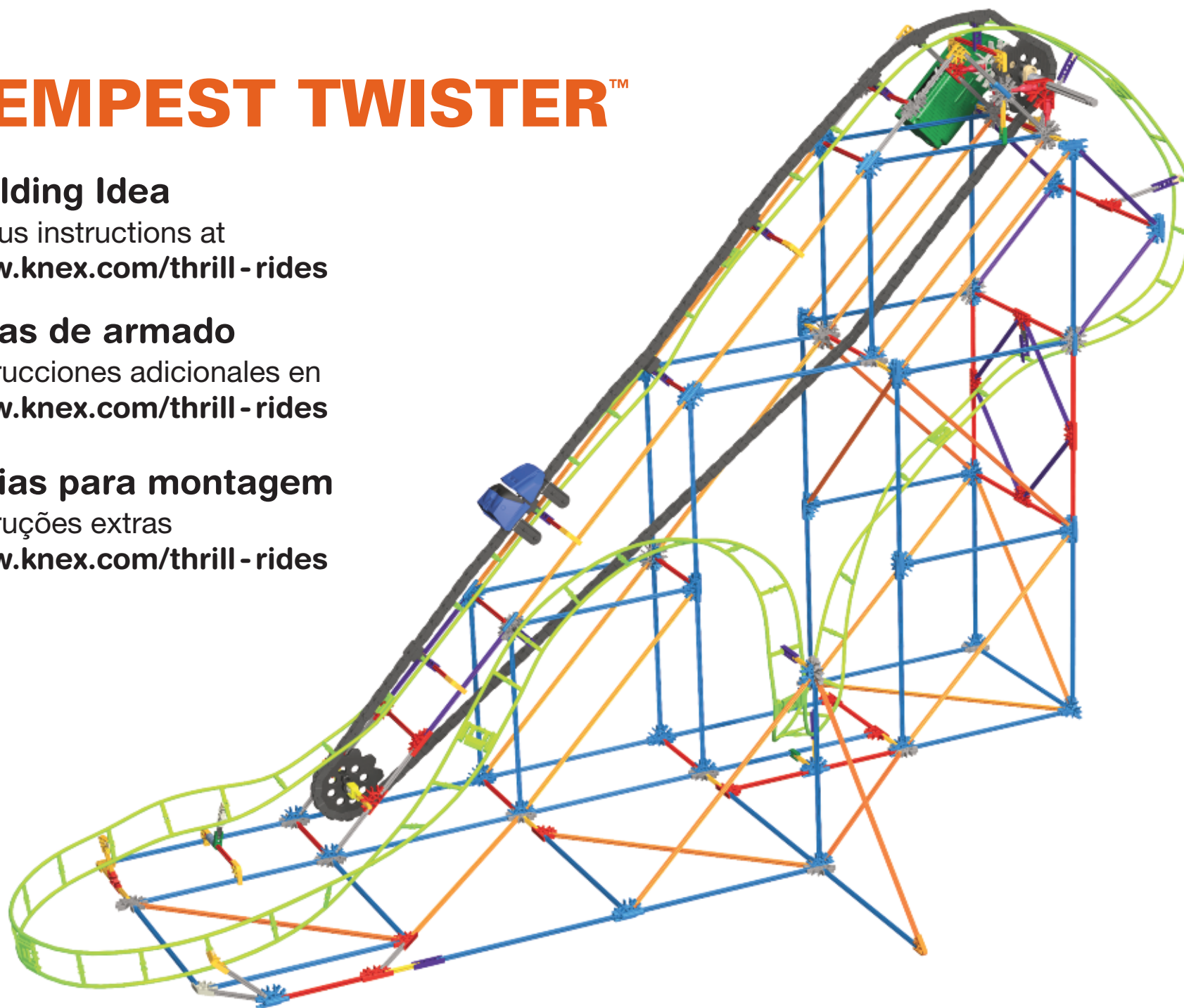

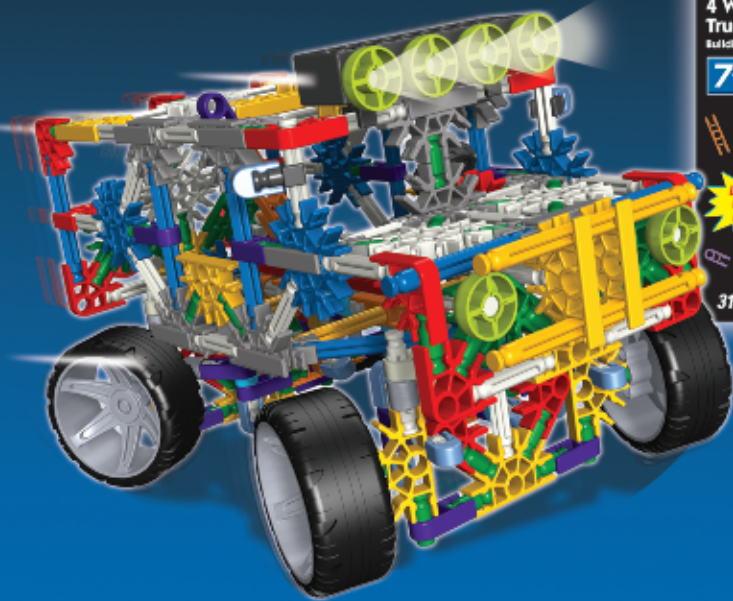

Sold separately.
Se venden por separado.
Vendidos separadamente.

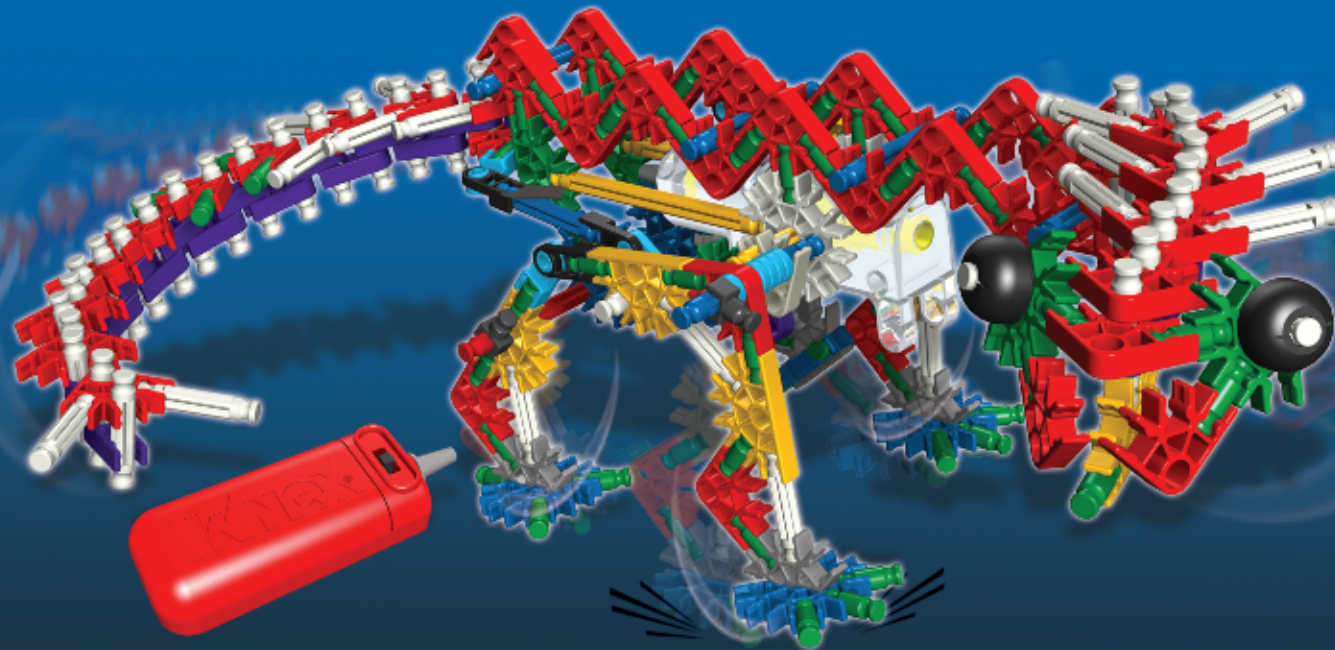

 [facebook.com/buildknex](https://www.facebook.com/buildknex)

1-800-KID-KNEX. (USA/EE.UU./États-Unis/Canada); email@knex.com; www.knexus.com. Customer outside the USA/Canada contact your local distributor at www.knexus.com/distributors (ES) Los clientes fuera de EE. UU./Canadá pueden contactar a su distribuidor local en www.knexus.com/distributors (PT) Consumidores fora dos EUA ou Canadá devem entrar em contato com distribuidores locais da www.knexus.com/distributors (AU) (BE) (CL) (DE) (MX) (NL) (NZ) www.knexus.com/distributors. (UK) TOMY Careline, PO Box 20, Totton, Hants, SO40 3YF; Tel 023 8066 2600. (FR) ALLO TOMY SAV, Parc d'affaires international, 74166 ARCHAMPS ; Tel 0 820 013 013. (DE) (FR) (NL) (UK) www.tomy.eu

Product & colors may vary. Most models can be built one at a time. Standard K'NEX parts made in the USA. K'NEX is a registered trademark of K'NEX Limited Partnership Group.

El producto y los colores pueden variar. En la mayoría de los casos, es posible construir un solo modelo a la vez. Las piezas K'NEX estándar se fabrican en EE. UU. K'NEX es una marca registrada de K'NEX Limited Partnership Group.

O produto e as cores podem variar. Muitos modelos podem ser montados individualmente. Peças K'NEX padrão fabricadas nos EUA. A K'NEX é uma marca registrada da K'NEX Limited Partnership Group.

K'NEX and Imagine, Build, Play are registered trademarks of K'NEX Limited Partnership Group.

K'NEX y Imagine, Build, Play son marcas registradas de K'NEX Limited Partnership Group.

K'NEX e Imagine, Build, Play são marcas registradas da K'NEX Limited Partnership Group.

Manufactured under U.S. Patents/Fabricado bajo patentes de EE.UU./Fabricado sob patentes dos EUA 5,346,420; 5,350,331; 5,427,559.



Tomy S040 3SA, England

©2012 K'NEX Limited Partnership Group
P.O. Box 700
Hatfield, PA
19440-0700

151957-V2-01/12