

10801/62706

# REKONSTRUCTORS™

BUILD TO BATTLE, REBUILD TO SURVIVE!

CONSTRUIRE POUR COMBATTRE, RECONSTRUIRE POUR SURVIVRE!

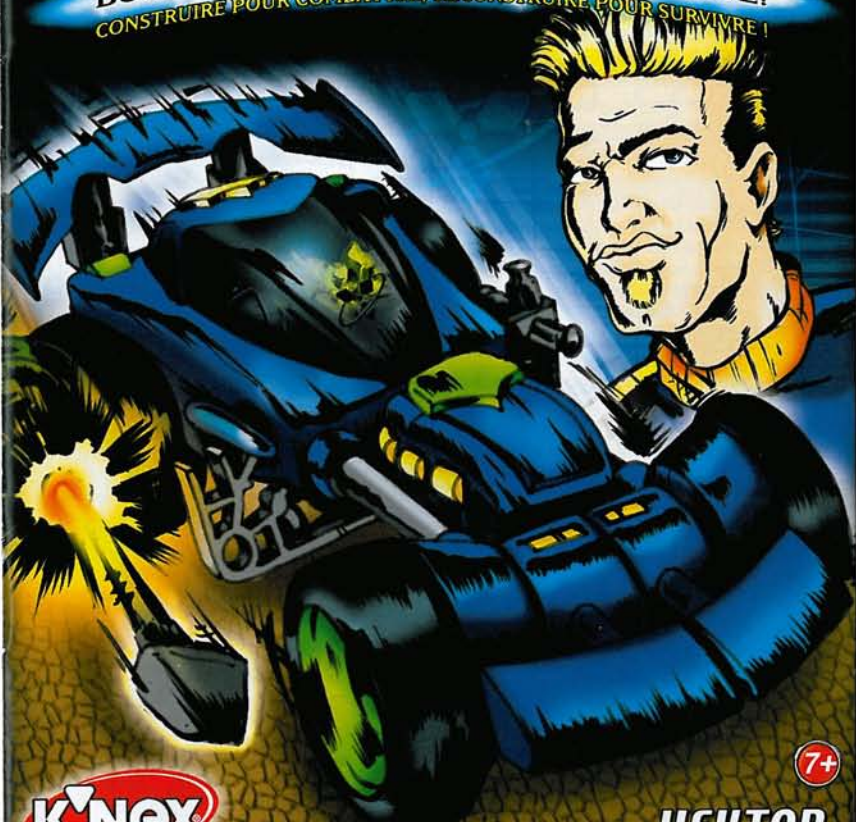

**K'NEX**

Building System    Système De Construction

7+

**VEKTOR™**



# VEKTOR™

As the youngest member of the XTractor Team, Jason Michaels is eager to please but often reacts without thinking, leading him into trouble. While orbiting ZeKor, the XTractors receive a garbled message from the Elite Pilots describing an incredible source of power before the transmission is cut short. Passing through ZeKor's atmosphere, the XTractors are fused with the equipment on board their ship. Upon regaining consciousness, Jason Michaels realizes that he has merged with the ship's dune buggy – and attached to his body is a glowing PowerCore.

Jason Michaels had become "Vektor."

Vektor's PowerCore gives him the ability to move so fast that everything around him freezes in time.

En tant que benjamin de l'XTractor Team, Jason Michaels déborde toujours d'enthousiasme, mais réagit souvent sans réfléchir, ce qui lui attire des ennuis. Alors qu'ils sont en orbite sur ZeKor, les XTractors reçoivent des pilotes d'élite un message embrouillé décrivant une fabuleuse source de puissance avant l'interruption de la transmission. Traversant l'atmosphère de ZeKor, les XTractors fusionnent avec le matériel qui se trouve à bord de leur vaisseau. En reprenant connaissance, Jason Michaels se rend compte qu'il a fusionné avec le jeep du vaisseau – et qu'un PowerCore incandescent est fixé à son corps.

Jason Michaels est devenu « Vektor. »

Vektor's PowerCore lui donne le pouvoir de se déplacer tellement rapidement que tout ce qui l'entoure se fige dans le temps.



AFTER CRASH LANDING, JAMMER TELLS THE OTHERS THAT HE HAS DETECTED 2 SIGNALS: A STRONG POWER FIELD AND A FAINT BLIP. AS JAMMER AND VEKTOR SET OFF FOR THE STRONG SIGNAL, BULLDOG HEADS FOR THE WEAKER ONE.

APRÈS UN ATERRISSAGE EN CATASTROPHE, JAMMER INDIQUE AUX AUTRES QU'IL A DISTINGUÉ 2 SIGNAUX: UN CHAMP DE PUISSANCE CLAIR ET UN SIGNAL TRÈS FAIBLE. JAMMER ET VEKTOR PARTANT À LA RECHERCHE DU SIGNAL CLAIR, BULLDOG SE DIRIGE VERS LE SIGNAL PLUS FAIBLE.



ZOOMING ACROSS THE  
ZEKORIAN SURFACE.

TRAVERSANT EN TROMBE  
LA SURFACE DE ZEKORIAN.

JAMMER, YOU CAN CHECK THIS  
OUT ALONE, RIGHT?

JAMMER, TU PEUX TE DÉBROUILLER  
TOUT SEUL, NON ?

SURE, VEKTOR.  
JUST BE CAREFUL.

BIEN SÛR, VEKTOR.  
MAIS FAIS ATTENTION.



FINALLY,  
SOME ADVENTURE!

ENFIN  
UN PEU D'ACTION !

**BRRRAAOOOOMM**

VEKTOR ENDS UP SPEEDING  
RIGHT INTO RAVAGE.

VEKTOR FINIT PAR RENTRER  
EN PLEIN DANS RAVAGE.

WHOA!  
WOW!



AS VEKTOR TURNS AROUND, HE REALIZES THAT RAVAGE NOW HAS HIM CORNERED.

EN SE RETOURNANT, VEKTOR SE REND COMPTE QU'IL EST COINCÉ PAR RAVAGE.

THERE'S NOT ENOUGH ROOM FOR ME TO SPEED UP AND USE MY POWERCORE!

IL N'Y A PAS ASSEZ DE PLACE POUR QUE JE PUISSE ACCÉLÉRER ET UTILISER MON POWERCORE!

RAVAGE STARTS HURLING MISSILES AT VEKTOR.

RAVAGE SE MET À LANCER DES MISSILES EN DIRECTION DE VEKTOR.

BBBWWRRROOM!  
BBBWWRRROOM!  
BBBWWRRROOM!



*RAVAGE LOOMS OVER VEKTOR, WHILE SHADOW APPEARS IN THE BACKGROUND.  
RAVAGE MENACE VEKTOR, TANDIS QUE SHADOW APPARAÎT EN ARRIÈRE-PLAN.*

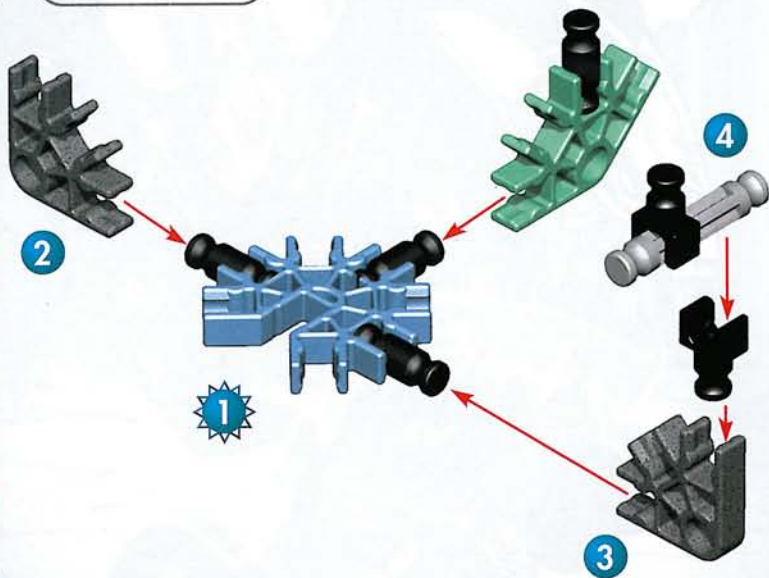

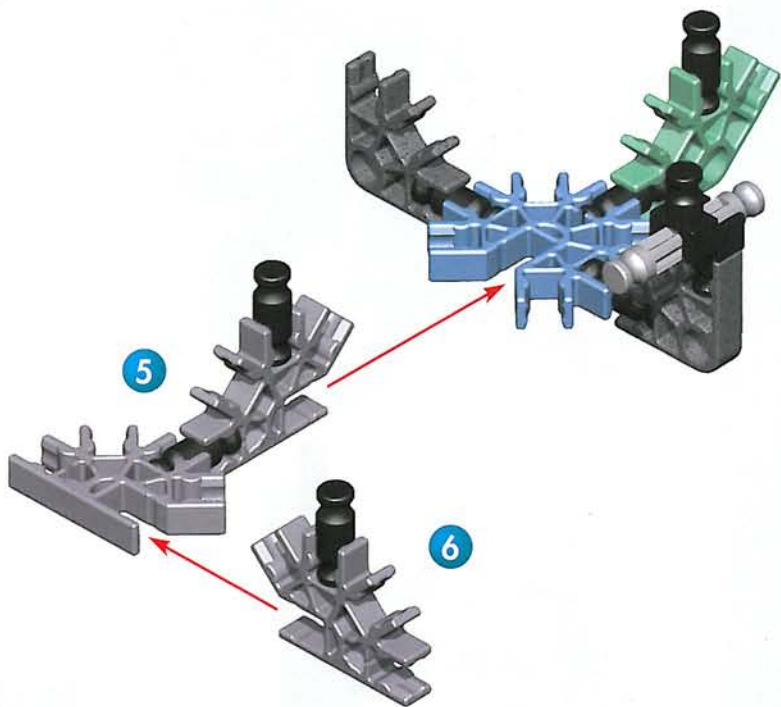

7





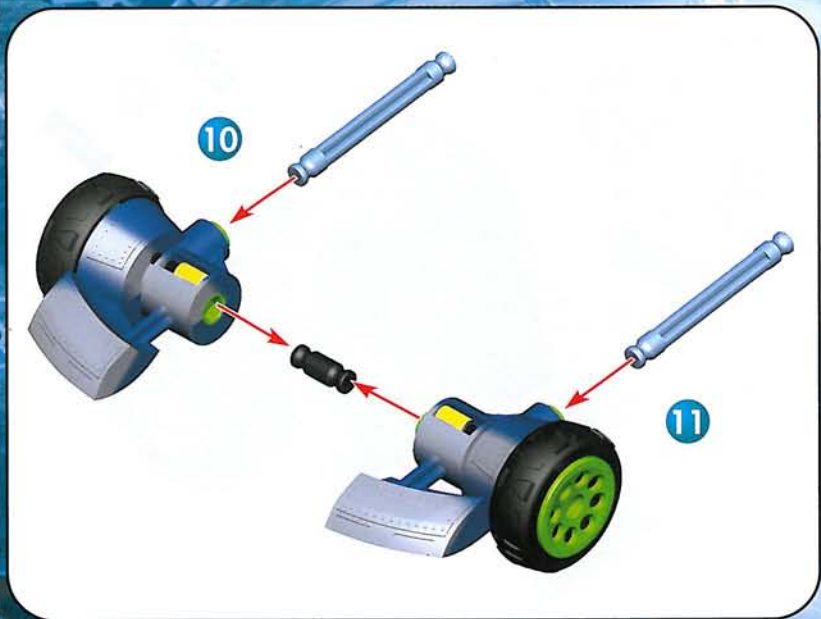

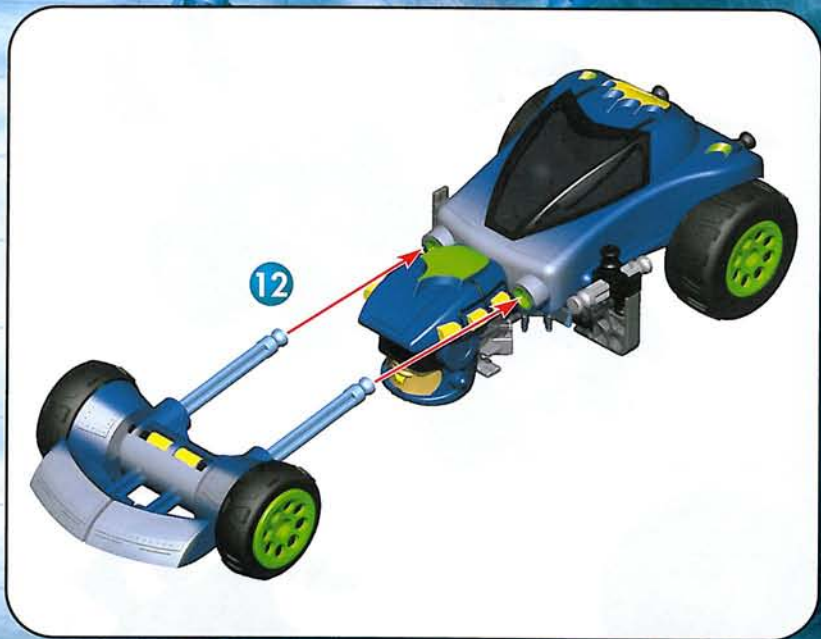



PowerCore™

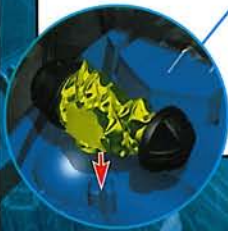

SHADOW BLASTS A MISSILE INTO RAVAGE.  
SHADOW TIRE UN MISSILE SUR RAVAGE.

NOW!  
GET OUTTA THERE!  
ALLEZ ! VA-T-EN !



VEKTOR YELLS **"ReKconstruct!"**  
AND CHANGES INTO BATTLE MODE.

VEKTOR HURLE « REKONSTRUCT ! »  
ET PASSE EN MODE DE COMBAT.



YOU'RE MINE NOW!  
TU ES À MOI MAINTENANT !



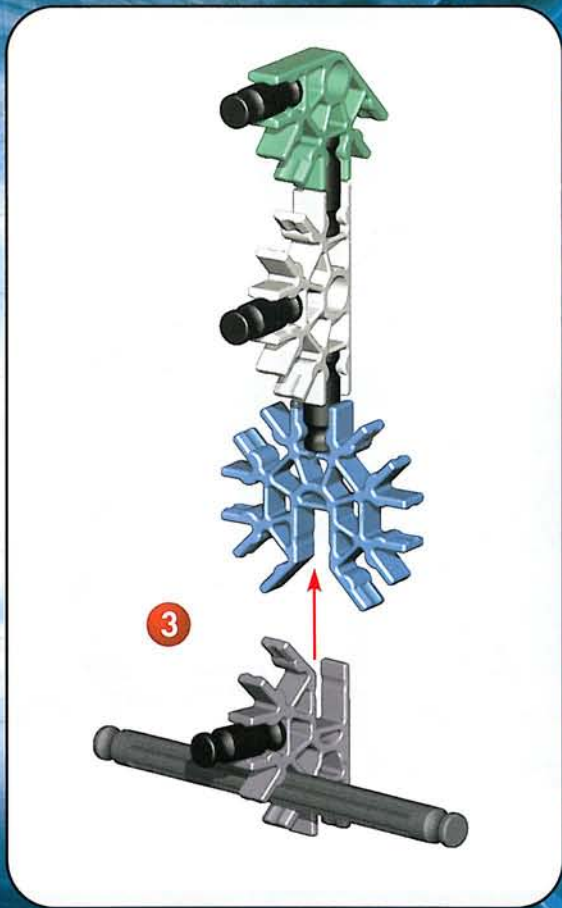

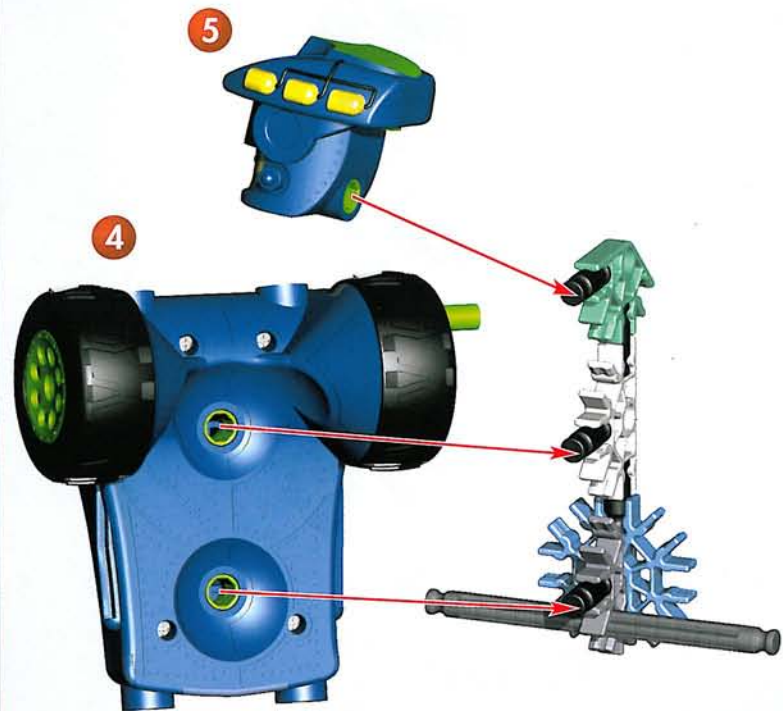

6



7



PowerCore™

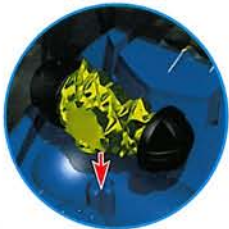

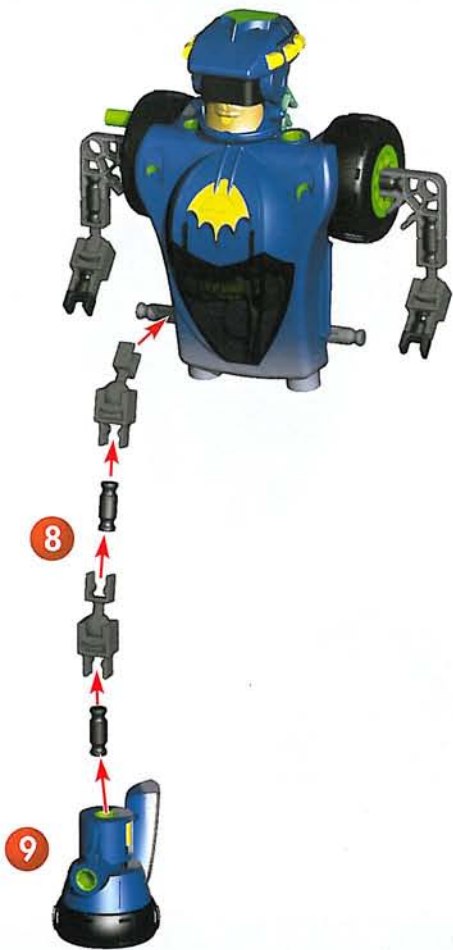

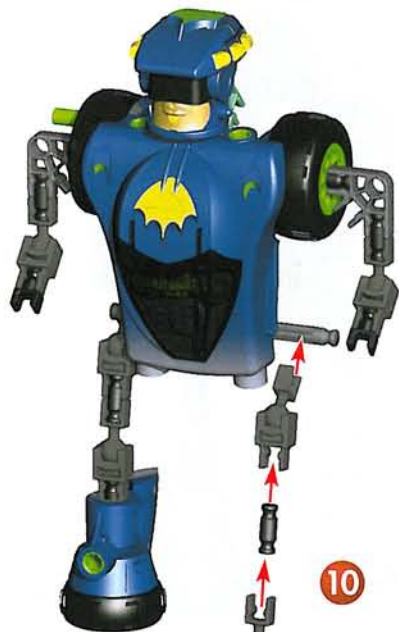

10



11

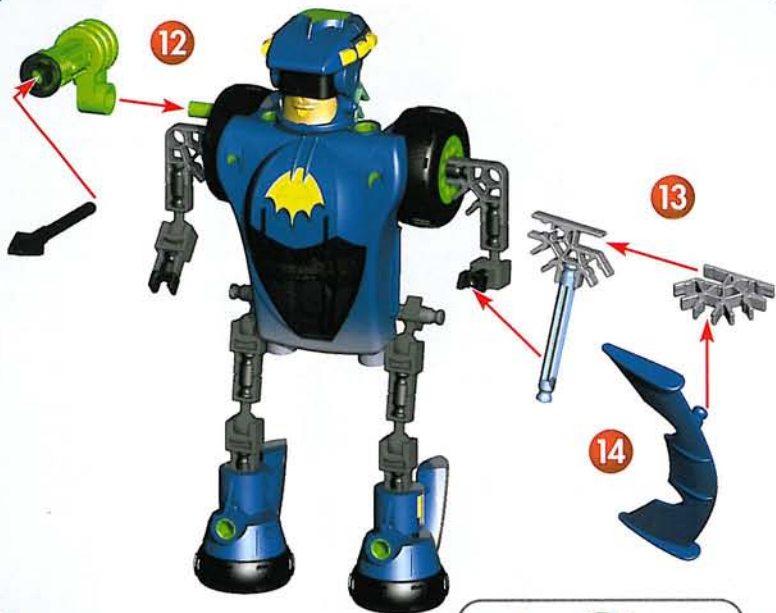

GOOD JOB!  
NOW, LET'S  
GET GOING!

BIEN JOLÉ !  
PARTONS  
MAINTENANT !

VEKTOR YELLS **"ReKconstruct!"**  
AND CHANGES INTO ESCAPE MODE.

VEKTOR HURLE << REKONSTRUCT ! >>  
ET PASSE EN MODE D'ÉVASION.

VEKTOR AND SHADOW  
LEAVE THE BATTLE  
DAMAGED RAVAGE.

VEKTOR ET SHADOW  
QUITTENT RAVAGE QUI  
EST ÉPUIsé PAR  
LA BATAILLE.

THANKS MAN I GOTTA  
FIND MY TEAMMATES.  
MERCI VIEUX FAUT QUE  
JE TROUVE MES  
CO-ÉQUIPIERS.

I BETTER TAG ALONG,  
HOTSHOT.  
VAUT MIEUX QUE JE VIENNE  
AVEC TOI, CHAMPION.

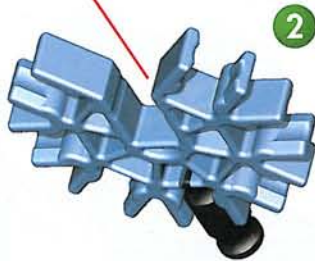
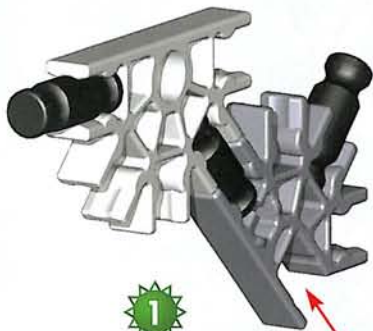

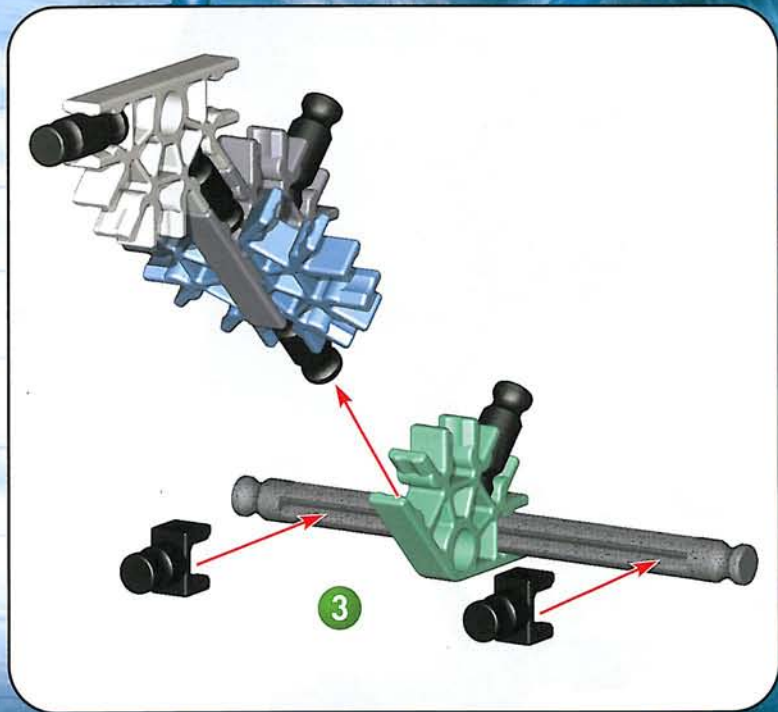

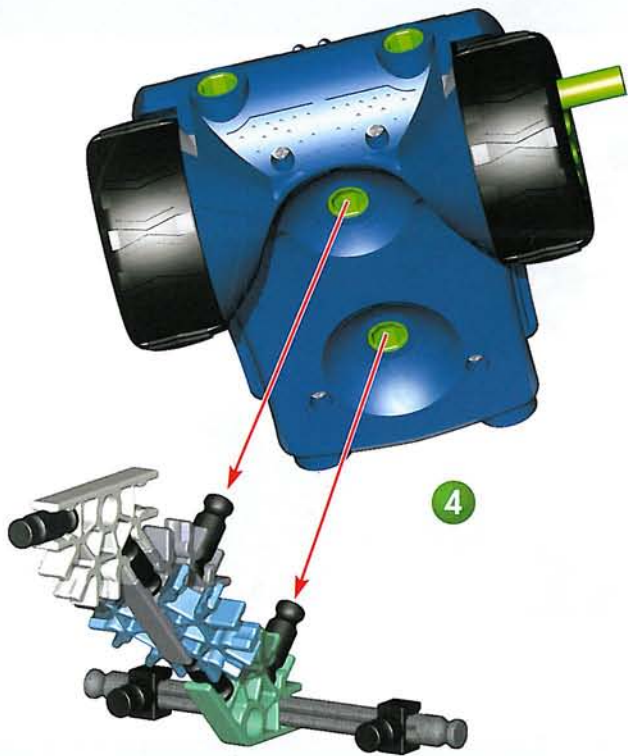

PowerCore™

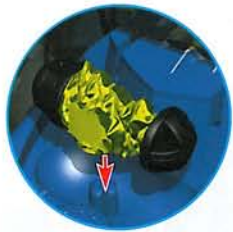

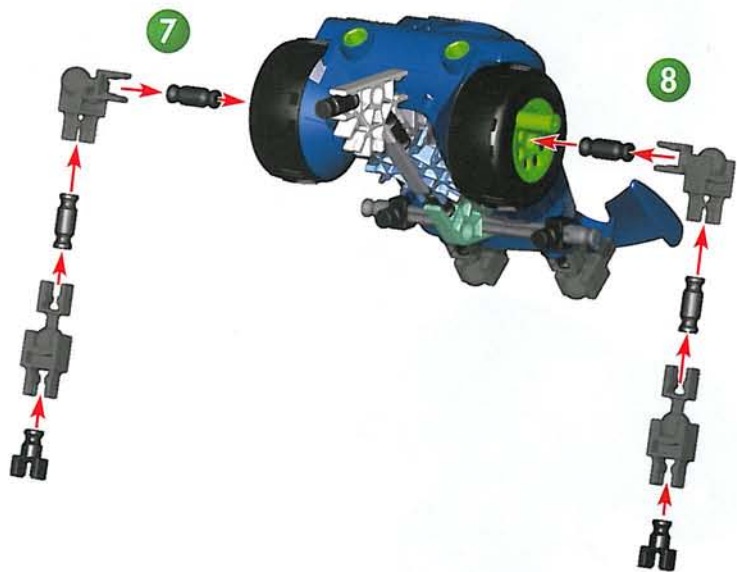

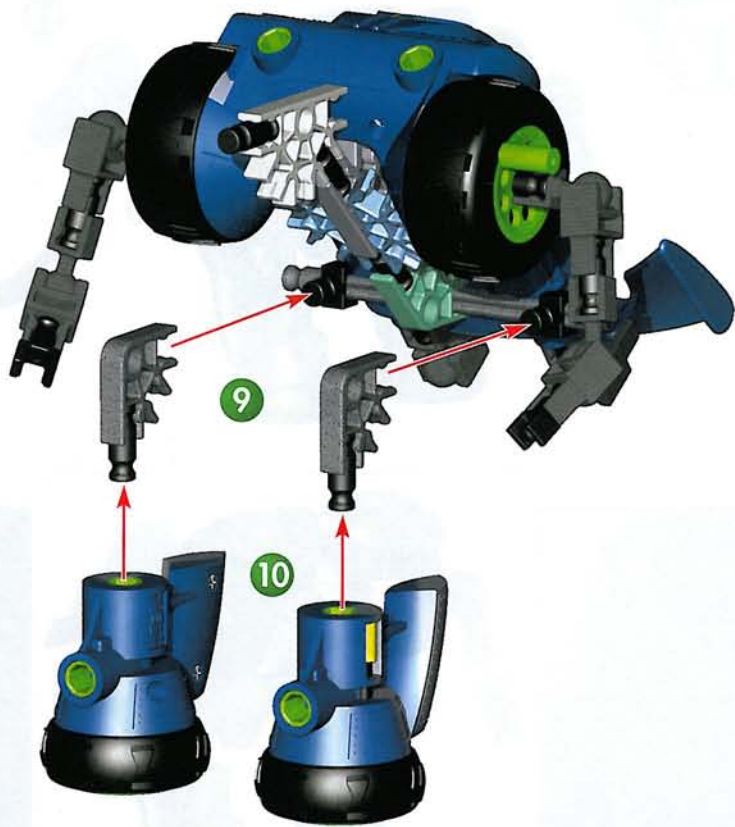

11

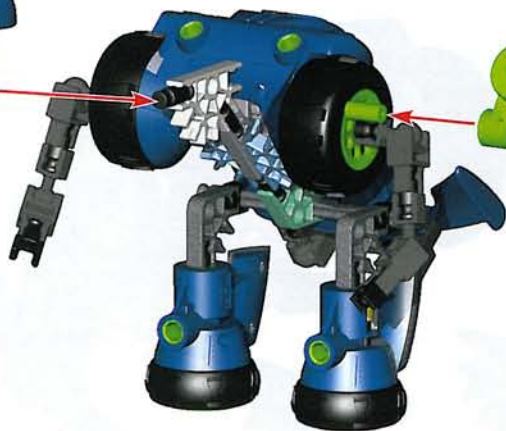

12



## SPECIAL FEATURES *ATTRIBUTS SPÉCIAUX*

PRESS BUTTON TO FIRE MISSILES

*APPUYE SUR LE BOUTON POUR  
PROPULSER LES MISSILES*

CHRONORUPT POWERCORE  
*POWERCORE CHRONORUPT*

INSERT MISSILE  
TO RELOAD  
*INTRODUIS UN MISSILE  
POUR RECHARGER*

RACING WHEELS  
*ROUES DE COURSE*

Caution: Do not launch in the direction of people, animals, or walls; you could cause injury or damage.  
Never attempt to launch any projectiles other than K'NEX missiles.

Mise en garde : ne pas lancer en direction de personnes, d'animaux, ou de murs pour éviter le risque de blesser quelqu'un ou de provoquer des dégâts. Ne jamais tenter de lancer d'autres projectiles que les missiles K'NEX.

Opgelet: Niet lanceren in de richting van mensen, dieren of muren; je zou letsel of schade kunnen veroorzaken. Nooit proberen om andere projectielen dan K'NEX raketten te lanceren.



# POWERCORE REGENERATING UNIT *UNITÉ DE RÉGÉNÉRATION DU POWERCORE*



You've captured the enemy's PowerCore (sold separately), and your own was depleted during the struggle. Now is the time to regenerate them both for use in your next battle. Place both PowerCores in the PCRU, recharge, and be prepared for the next fight!

*Tu as capturé le PowerCore de l'ennemi (vendu séparément), et le tien a été affaibli au cours de la bataille. Est maintenant l'heure de les régénérer tous les deux pour l'usage dans votre prochaine bataille. Placez les deux noyaux de puissance dans le PCRU, recharge, et soyez préparé pour le prochain combat!*

## PARTS COUNT *NOMBRE DE PIÈCES*



[www.REKONSTRUCTORS.com](http://www.REKONSTRUCTORS.com)

Enter all 3 XTractor codes for complete, online Mega-Build instructions.

Entre les codes de tous les 3 XTractor pour obtenir en ligne des instructions complètes de Mega-Build.

**DYNAMIX**



VEKTOR: 10801

BULLDOG: ----

JAMMER: ----

Enter *THEIR* World - Get the Story, Play the Game!  
Entre dans *LEUR* monde - Connais l'histoire, Joue le jeu !



**Collect 'em All! Collectionne-les tous!**

**Elite Pilots™**



**DIESEL™**



**SHADOW™**



**RYDER™**



**Zekorian Creatures™**



**RAVAGE™**



**RAZOR™**



**TEMPEST™**

# XTractors™



SKYHAWK™



BULLDOG™



VEKTOR™



JAMMER™



RELIC™





©2003 K'NEX Industries, Inc. P.O. Box 700 Hatfield, PA 19440-0700



**US** 1-800-KID-KNEX US/Canada only (English only)

**GB** 00800-22427276 UK/Ireland only

**F E D NL** 001-215-996-4823



**US** Consumer Services  
K'NEX Industries, Inc.  
P.O. Box 700  
Hatfield, PA 19440-0700



**GB** K'NEX  
Newport Consumer Services  
Hasbro UK Ltd., Caswell Way  
Newport, Gwent NP9 0YH



[www.knex.com](http://www.knex.com)



[email@knex.com](mailto:email@knex.com)



**WARNING:**

**CHOKING HAZARD-** Small parts.  
Not for children under 3 years.



**AVERTISSEMENT:**

**DANGER D'ÉTOUFFEMENT-** Pièces de petite  
taille Ne pas donner aux enfants de moins de 3 ans.



**WAARSCHUWING:**

**VERSTIKKINGSGEVAAR-** In verband met kleine  
onderdelen niet geschikt voor kinderen tot 3 jaar.

Printed in China  
Imprimerie aux China

Product and colors may vary. Models can be built one at a time. K'NEX is a registered trademark of K'NEX Industries, Inc.  
Le produit et les couleurs peuvent varier. La plupart des modèles peuvent être construits un à la fois.  
K'NEX est une marque déposée de K'NEX Industries, Inc.

Manufactured under U.S. Patents/Fabriqué sous brevets américains 5,061,219; 5,137,486; 5,199,919; 6,460,572.  
Other U.S. and foreign patents pending. Autres brevets américains et étrangers en instance.

Conforms to the Requirements of ASTM Standard Consumer Safety Specification on Toy Safety, F963-96a.  
Conforme aux spécifications de sécurité du consommateur sur la sécurité des jouets  
de la norme ASTM F963-96a.

Visit the website for the complete ReConstructors story, online Comics and Game!

Visitez le site web pour l'intégralité du récit des ReConstructors, des bandes dessinées en ligne et un jeu !

[www.REKONSTRUCTORS.com](http://www.REKONSTRUCTORS.com)



404010.11-U1-8/03