

REKONSTRUCTORS™

ONE BATTLE... 3 WAYS TO SURVIVE!
UNE BATAILLE... TROIS MOYENS DE SURVIVRE !



K'NEX

Building System
Système De Construction

7+

SKYHAWK™



SKYHAWK™

Due to Earth's depleted resources, a squadron of elite pilots was sent to find a new energy source. Skyhawk, also known as Alex Hunter, is second in command. He was chosen for the exploration team because he remains very calm in tense situations, allowing him to strategize when the team needs answers. When his space cruiser passed through a magnetic storm, the ship crashed on the planet ZeKor. Upon regaining consciousness, Alex Hunter found his body had combined with the metal of the ship and attached to his new metallic body was a glowing PowerCore. "Alex Hunter" became "Skyhawk".

Skyhawk's PowerCore gives him an impenetrable Force Field. This power protects Skyhawk when he enters battle and it allows him time to plan on the fly.

Skyhawk's leadership abilities combined with his aerial expertise and uncanny battle planning make him an irreplaceable member of the elite pilots.

Les ressources de la Terre étant de plus en plus réduites, une escadrille de pilotes d'élite est envoyée en mission pour trouver une nouvelle source d'énergie. Skyhawk, connu également sous le nom d'Alex Hunter est le commandant adjoint. Il a été choisi par l'équipe d'exploration parce qu'il reste très calme lorsqu'il se trouve confronté à des situations épineuses, et cela lui permet d'élaborer des stratégies lorsque l'équipe a besoin de trouver des réponses.

En reprenant connaissance, Alex Hunter a découvert que son corps avait fusionné avec le métal du vaisseau, et que, fixée à ce nouveau corps métallique, rayonnait un PowerCore. « Alex Hunter » est devenu « Skyhawk ».

Le PowerCore de Skyhawk l'entoure d'un champ de force impénétrable. Ce pouvoir protège Skyhawk lorsqu'il se trouve confronté à une bataille et lui permet de prendre des décisions en un « clin d'œil ». Les aptitudes de leadership de Skyhawk associées à son expertise aérienne et son sens étonnant de la stratégie font de lui un membre irremplaçable de l'équipe de pilotes d'élite.



SKYHAWK, SCOUTING THE ZEKORIAN
LANDSCAPE, SPOTS RAZOR GUARDING
A MYSTERIOUS CAVE ENTRANCE.

SKYHAWK, QUI EFFECTUE UNE
RECONNAISSANCE DU TERRAIN
ZEKORIAN, REPÈRE RAZOR QUI
MONTE LA GARDE À L'ENTRÉE D'UNE
GROTTE MYSTÉRIEUSE.





AS SKYHAWK IS FLYING
BY, RAZOR SPOTS HIM.
SKYHAWK QUI EST DANS
LES AIRS À PROXIMITÉ,
EST REPÉRÉ PAR
RAZOR.



INSTANTLY, RAZOR, USING HIS
HOLOGRAM POWERCORE,
MAKES DUPLICATES OF
HIMSELF APPEAR.

EN UN CLIN D'ŒIL, RAZOR,
UTILISANT SON POWERCORE
HOLOGRAMME, FAIT
APPARAÎTRE DES DOUBLES
DE LUI-MÊME.



"WHAT THE...?
WHERE DID THEY ALL COME FROM?"
NOM D'LINE PIPE...?
D'OÙ SORTENT-ILS ?

RAZOR LAUNCHES A DISK FROM HIS TAIL, BUT WITH ALL THE HOLOGRAMS, IT APPEARS TO SKYHAWK AS A SKY FULL OF DISKS.

RAZOR LANCE UN DISQUE À PARTIR DE SA QUEUE, MAIS À CAUSE DE TOUS LES HOLOGRAMMES, SKYHAWK A L'IMPRESSION QUE LE CIEL EST CONSTELLÉ DE DISQUES.



SKYHAWK USES HIS **FORCE FIELD** POWERCORE TO SURROUND HIMSELF, AND THEN SHOWS OFF SOME FLYING EXPERTISE, AVOIDING ALL THE EXPLOSIONS.

SKYHAWK UTILISE SON POWERCORE CHAMP DE FORCE POUR SE PROTÉGER, PLUS DÉMONTRE SON HABILETÉ EN VOL, EN ÉVITANT TOUTES LES EXPLOSIONS.





SKYHAWK BATTLES BACK,
FIRING MISSILES TOWARD RAZOR.

SKYHAWK RÉPOND, EN TIRANT
DES MISSILES EN DIRECTION
DE RAZOR.

ONE OF SKYHAWK'S
MISSILES, APPARENTLY
A DIRECT HIT, PASSES
RIGHT THROUGH
ONE OF THE
HOLOGRAPHIC
RAZORS.

L'UN DES MISSILES DE
SKYHAWK, UNE
FRAPPE DIRECTE
APPAREMMENT,
TRAVERSE TOUT
BONNEMENT
L'UN DES RAZORS
HOLOGRAPHIQUES.



"IT WENT RIGHT
THROUGH HIM...!?"
CELA L'A TRAVERSÉ !?"

"I HAVE A PLAN TO
FIND THE REAL RAZOR."
J'AI UNE IDÉE POUR
TROUVER LE VÉRITABLE
RAZOR.



SKYHAWK, SCOUTING THE ZEKORIAN
LANDSCAPE, SPOTS RAZOR GUARDING
A MYSTERIOUS CAVE ENTRANCE.

SKYHAWK, QUI EFFECTUE UNE
RECONNAISSANCE DU TERRAIN
ZEKORIAN, REPÈRE RAZOR QUI
MONTE LA GARDE À L'ENTRÉE D'UNE
GROTTE MYSTÉRIEUSE.



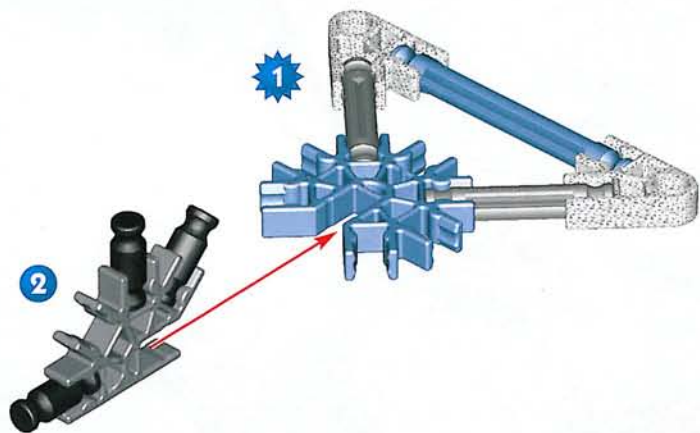

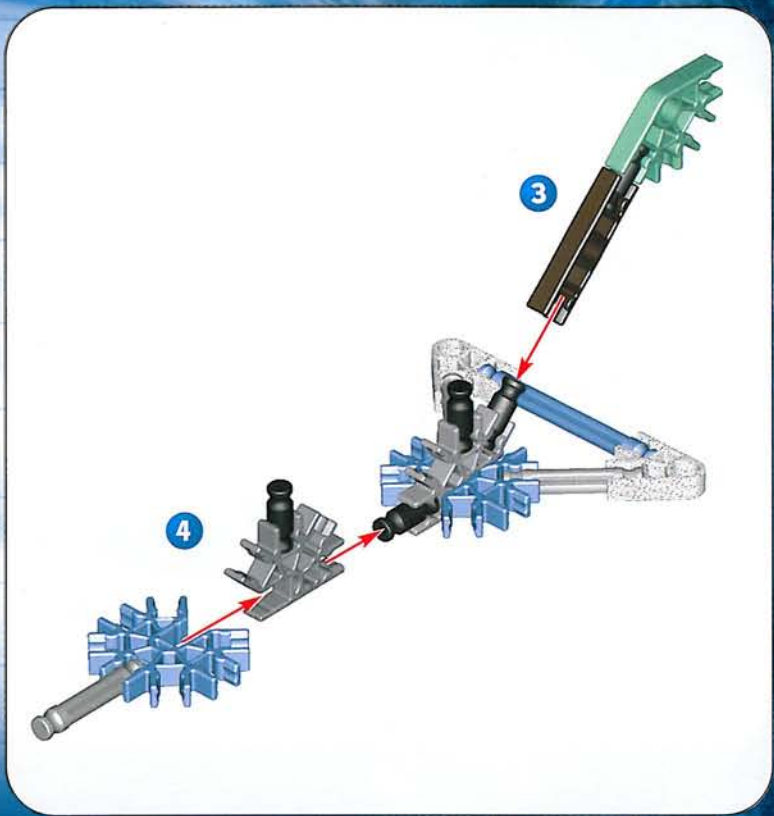

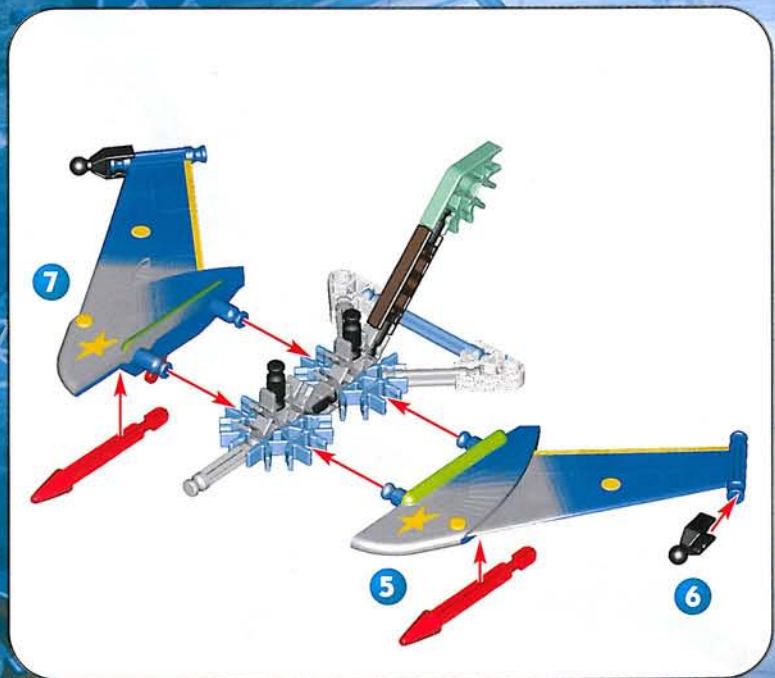

8



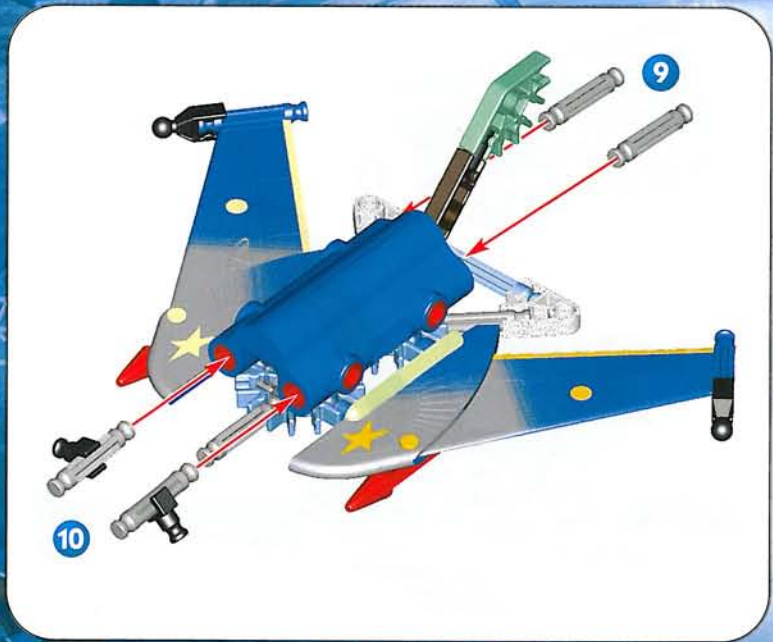

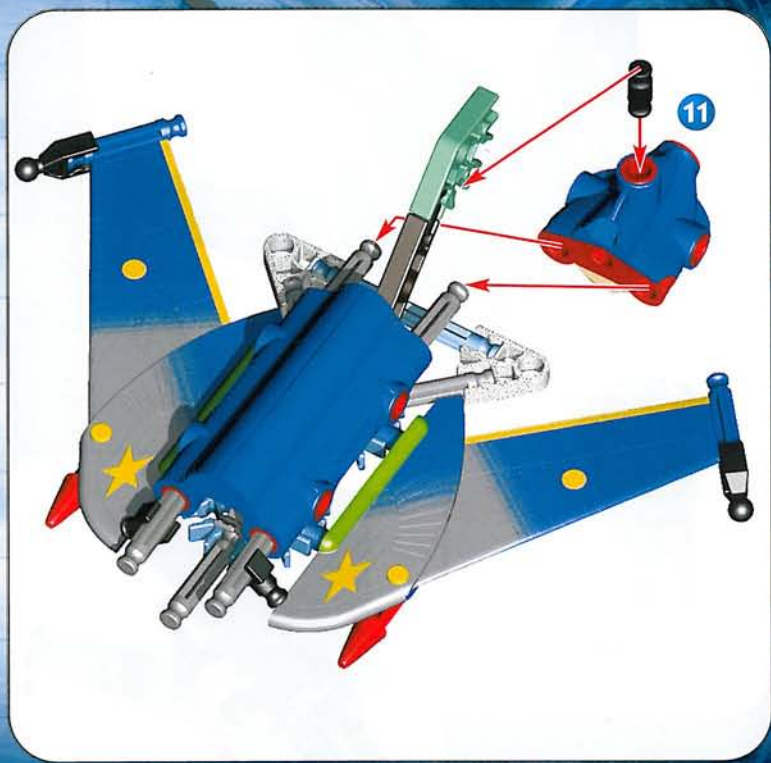



12



13





SKYHAWK INITIATES HIS POWERCORE FORCE FIELD AND BLASTS ALL THE SURROUNDING RAZORS.

SKYHAWK LANCE SON CHAMP DE FORCE POWERCORE ET TIRE SUR TOUS LES RAZORS QUI LE CERNENT.



AS THEY ARE BLASTED BACK, THE HOLOGRAMS BEGIN TO DISAPPEAR, LEAVING THE ONE REAL RAZOR.

ÉTANT ATTEINTS PAR LE FEU, LES HOLOGRAMMES COMMencent À DISPARAÎTRE, NE LAISSANT QUE LE VÉRITABLE RAZOR.



SHOUTING THE WORD **"ReKconstruct!"** SKYHAWK CHANGES MODE TO BATTLE RAZOR.

HURLANT LE MOT « REKONSTRUCT ! », SKYHAWK CHANGE DE MODE POUR SE MESURER À RAZOR.

1



2



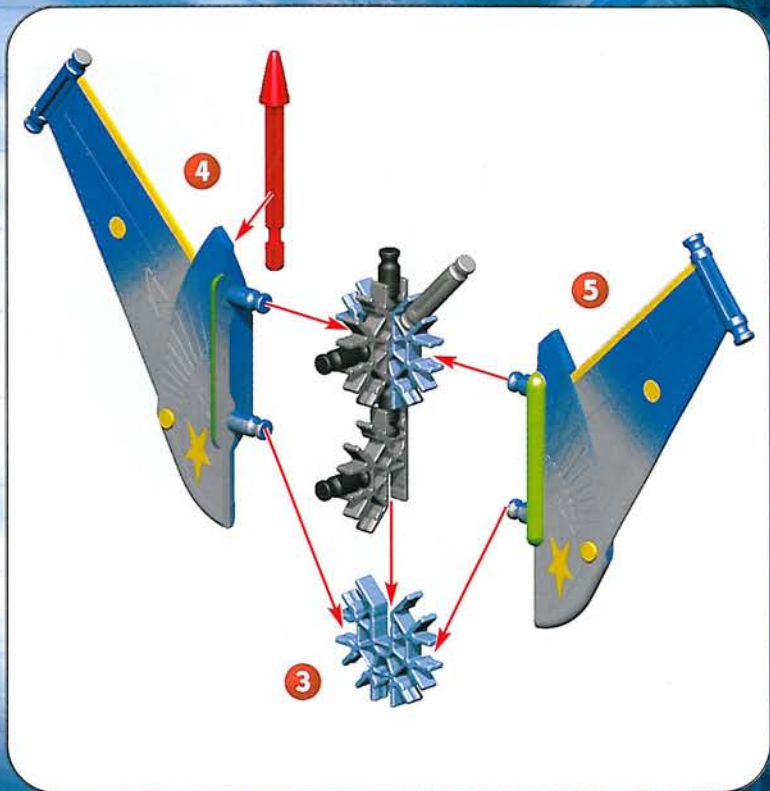

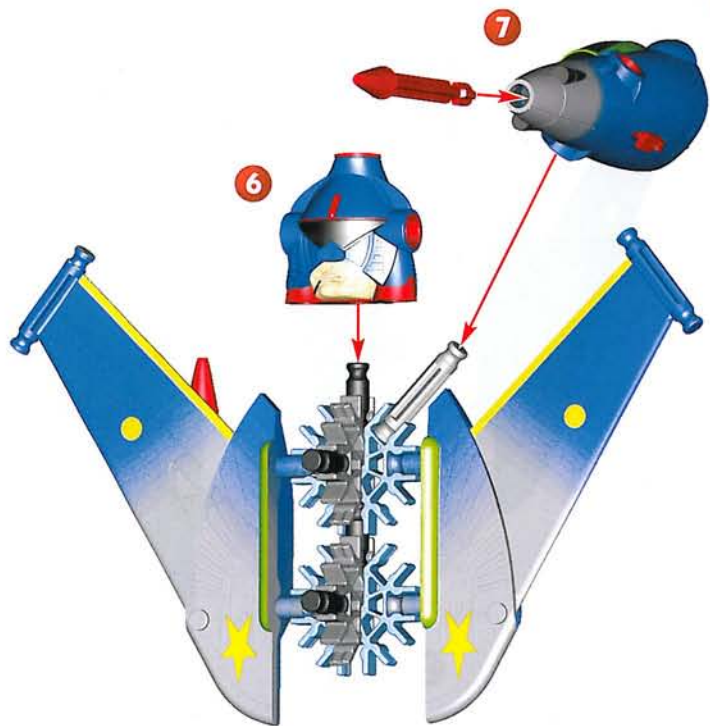

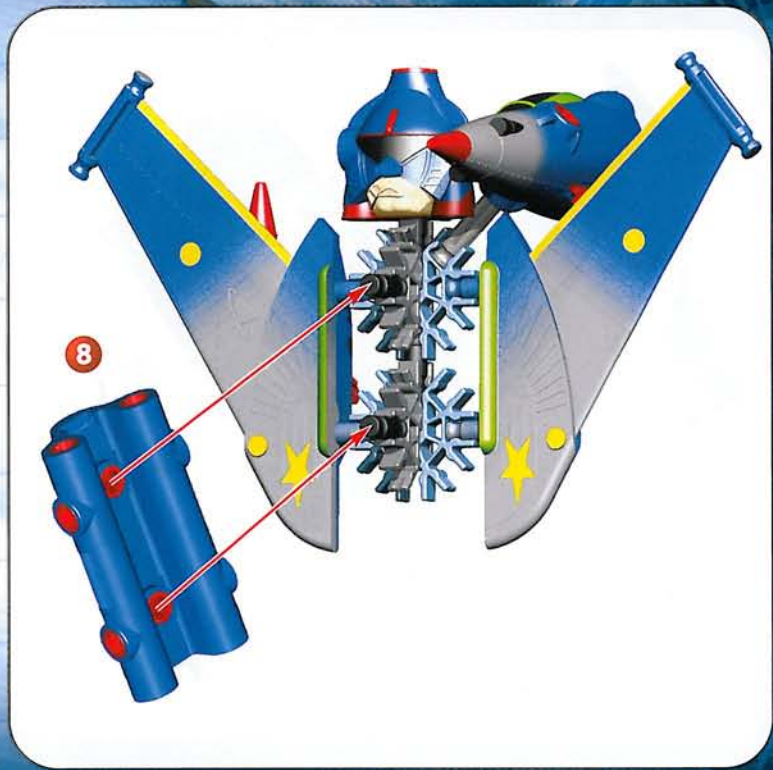

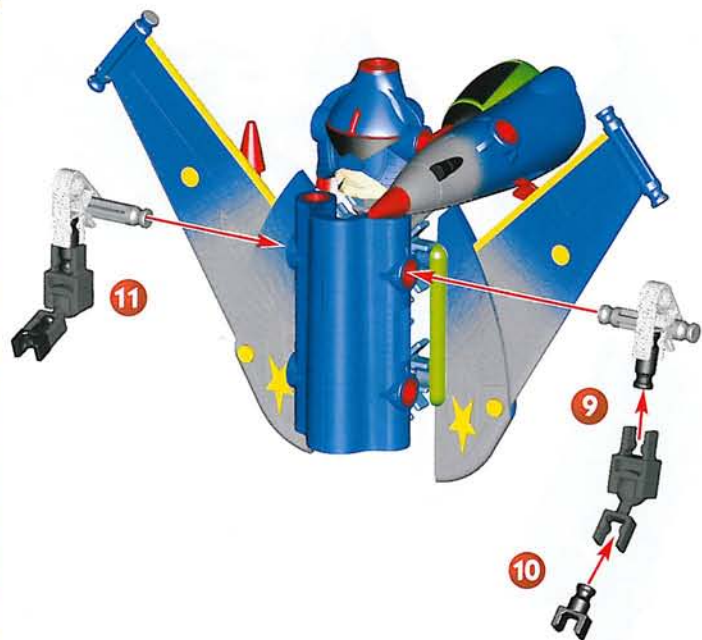

12



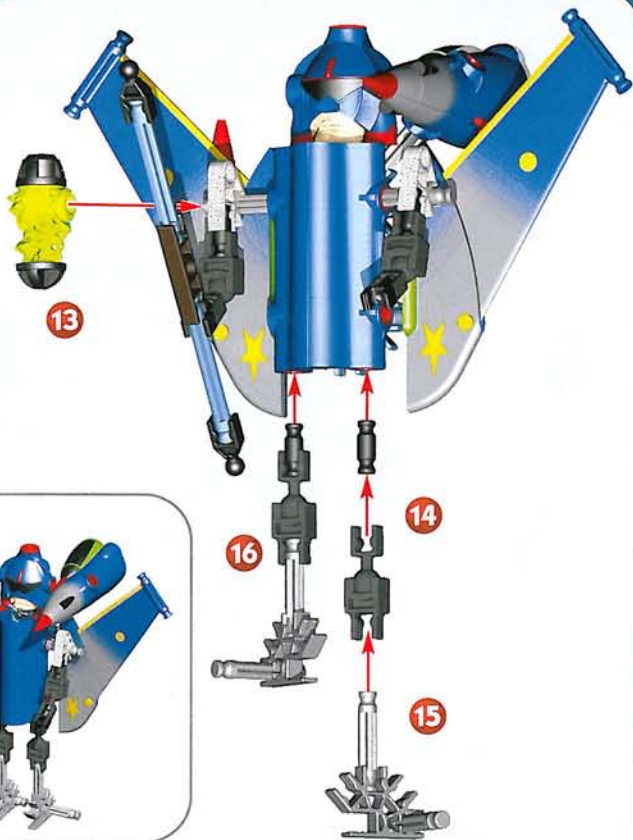



IN HIS NEW MODE, SKYHAWK BLASTS RAZOR.
DANS SON NOUVEAU MODE, SKYHAWK TIRE
VIGOREUSEMENT SUR RAZOR.

AS HE COLLECTS THE DEFEATED CREATURE'S POWERCORE
HE AGAIN SHOUTS **"ReKconstruct!"** TO CHANGE
MODE AGAIN.

RÉCOLTANT LE POWERCORE DE LA CRÉATURE VAINCUE,
IL HURLE DE NOUVEAU « REKONSTRUCT ! » AFIN DE
PASSER EN MODE DE FUITE.



LEAVING RAZOR DEFEATED AND POWERLESS,
SKYHAWK ENTERS INTO THE MYSTERIOUS CAVE
RAZOR WAS GUARDING.

ABANDONNANT RAZOR, VAINCU ET SANS DÉFENSE,
SKYHAWK PÉNÈTRE DANS LA GROTTE MYSTÉRIEUSE
OÙ RAZOR MONTAIT LA GARDE.



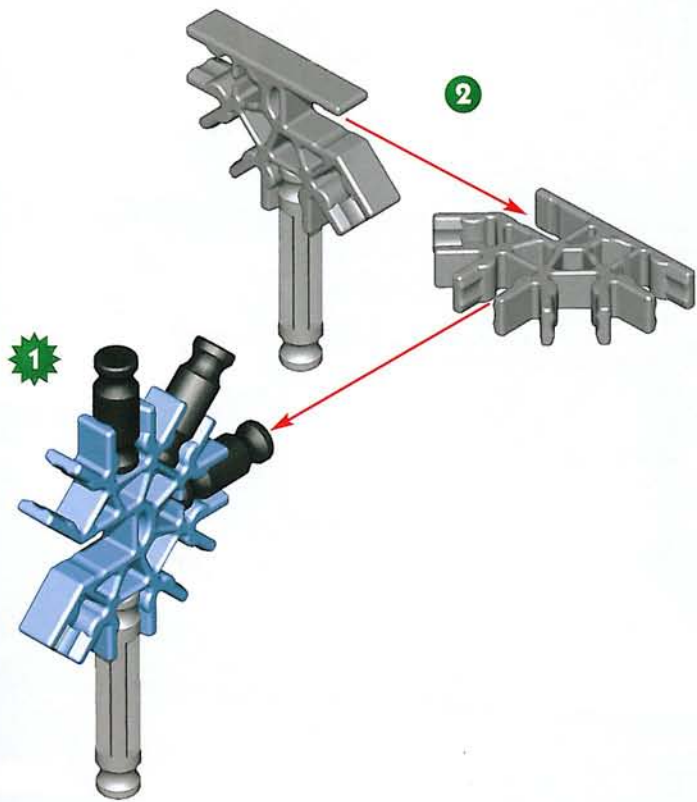

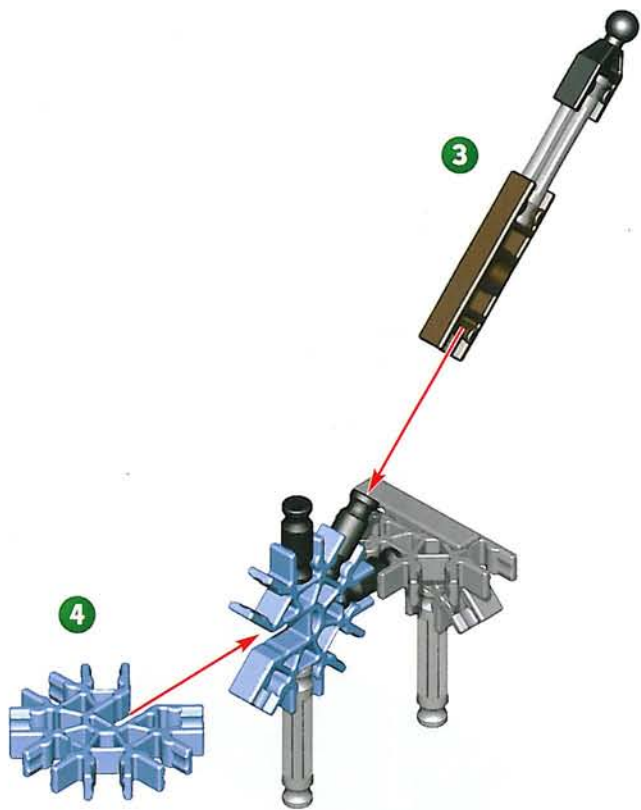

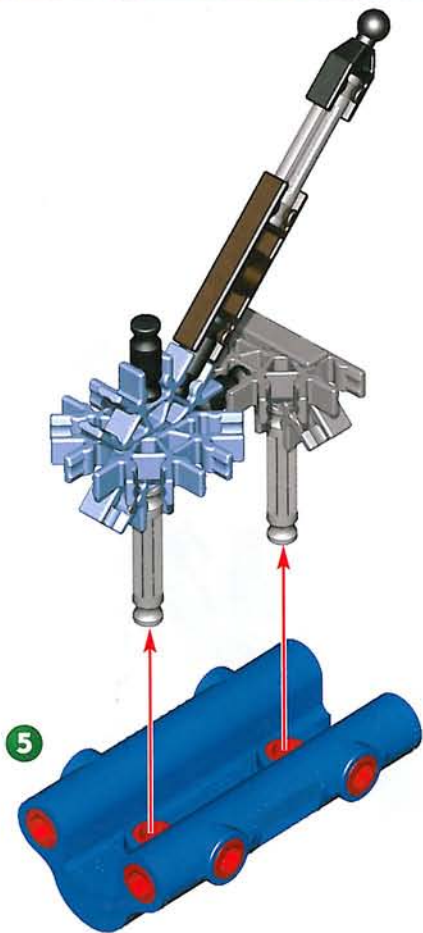

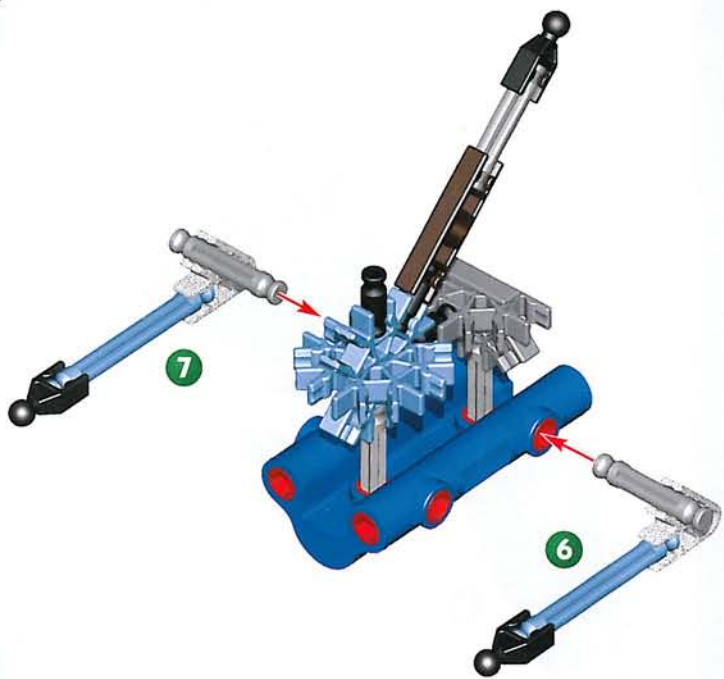

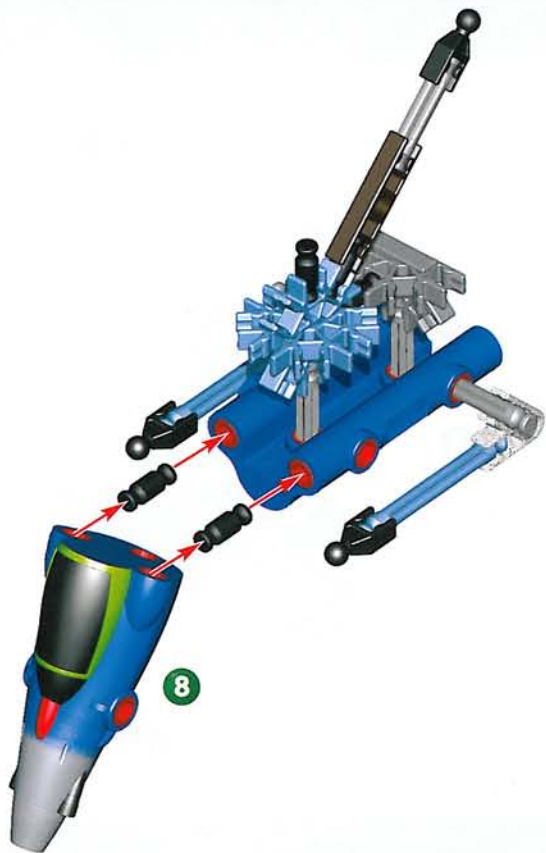

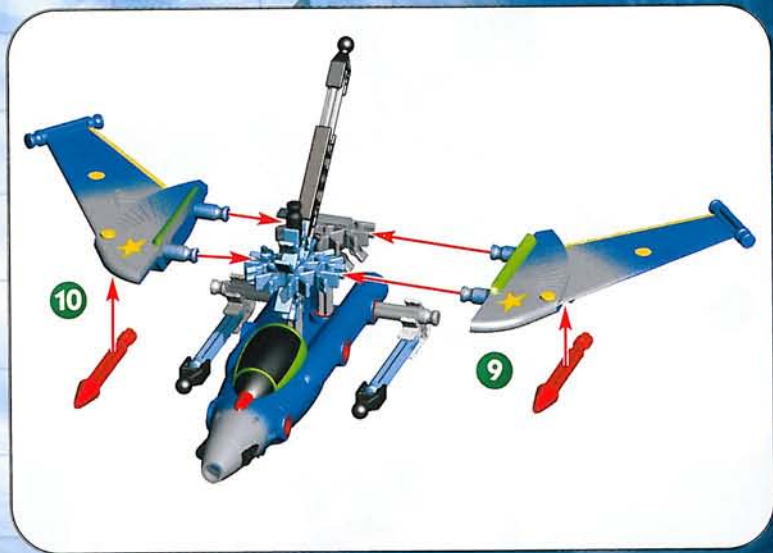



SPECIAL FEATURES *ATTRIBUTS SPÉCIAUX*

FORCE FIELD
POWERCORE
*POWERCORE DE
CHAMP DE FORCE*

PRESS BUTTON
TO FIRE MISSILES
*APPUYE SUR LE BOUTON POUR
PROPULSER LES MISSILES*

ADJUSTABLE WINGS
AILES RÉGLABLES

INSERT MISSILE TO RELOAD
*INTRODUIS UN MISSILE
POUR RECHARGER*

Caution: Do not launch in the direction of people, animals, or walls; you could cause injury or damage.
Never attempt to launch any projectiles other than K'NEX missiles.

Mise en garde : ne pas lancer en direction de personnes, d'animaux, ou de murs pour éviter le risque de blesser quelqu'un ou de provoquer des dégâts. Ne jamais tenter de lancer d'autres projectiles que les missiles K'NEX.

Opgelet: Niet lanceren in de richting van mensen, dieren of muren; je zou letsel of schade kunnen veroorzaken. Nooit proberen om andere projectielen dan K'NEX raketten te lanceren.

POWERCORE REGENERATING UNIT *UNITÉ DE RÉGÉNÉRATION DU POWERCORE*



You've captured the enemy's PowerCore (sold separately), and your own was depleted during the struggle. Now is the time to regenerate them both for use in your next battle. Place both PowerCores in the PCRU, recharge, and be prepared for the next fight!

Tu as capturé le PowerCore de l'ennemi (vendu séparément), et le tien a été affaibli au cours de la bataille. Est maintenant l'heure de les régénérer tous les deux pour l'usage dans votre prochaine bataille. Placez les deux noyaux de puissance dans le PCRU, recharge, et soyez préparé pour le prochain combat !

PARTS COUNT *NOMBRE DE PIÈCES*

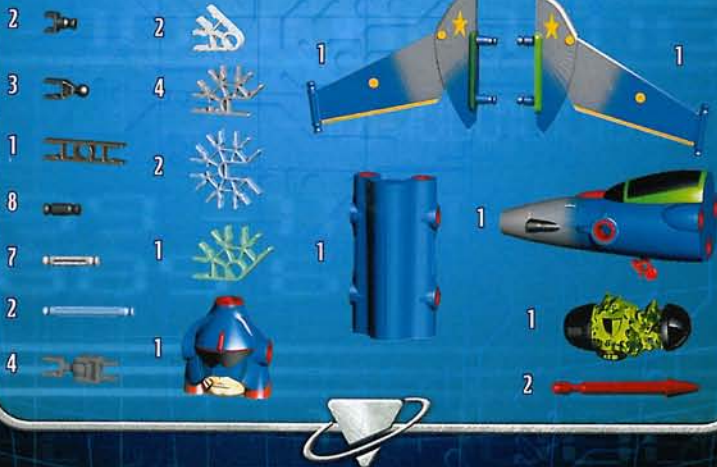

www.REKONSTRUCTORS.com

Enter all 3 elite pilot codes for complete, online Mega-Build instructions.

Entre les codes de tous les 3 pilotes d'élite pour obtenir en ligne des instructions complètes de Mega-Build.

MEGA BUILD



RYDER: ----
SHADOW: ----
SKYHAWK: 10837

Enter THEIR World - Get the Story, Play the Game!
Entre dans LEUR monde - Connais l'histoire, Joue le jeu!



Collect 'em All!
Collectionne-les tous!

RAZOR™

SKYHAWK™

Remote Control
RAVAGE™

RELIC™



TEMPEST™



SHADOW™

DIESEL™

RYDER™



©2003 K'NEX Industries, Inc. P.O. Box 700 Hatfield, PA 19440-0700



US 1-800-KID-KNEX US/Canada only (English only)

GB 00800-22427276 UK/Ireland only

F E D NL 001-215-996-4823



US Consumer Services
K'NEX Industries, Inc.
P.O. Box 700
Hatfield, PA 19440-0700



GB K'NEX
Newport Consumer Services
Hasbro UK Ltd., Caswell Way
Newport, Gwent NP9 0YH



www.knex.com



email@knex.com



WARNING:

CHOKING HAZARD- Small parts.
Not for children under 3 years.



AVERTISSEMENT:

DANGER D'ÉTOUFFEMENT- Pièces de petite
taille Ne pas donner aux enfants de moins de 3 ans.



WAARSCHUWING:

VERSTIKKINGSGEVAAR- In verband met kleine
onderdelen niet geschikt voor kinderen tot 3 jaar.

Printed in China
Imprimerie aux China

Product and colors may vary. Models can be built one at a time. K'NEX is a registered trademark of K'NEX Industries, Inc. Le produit et les couleurs peuvent varier. La plupart des modèles peuvent être construits un à la fois. K'NEX est une marque déposée de K'NEX Industries, Inc.

Manufactured under U.S. Patents/Fabriqué sous brevets américains 5,061,219; 5,137,486; 5,199,919; 6,460,572. Other U.S. and foreign patents pending. Autres brevets américains et étrangers en instance.

Conforms to the Requirements of ASTM Standard Consumer Safety Specification on Toy Safety, F963-96a. Conforme aux spécifications de sécurité du consommateur sur la sécurité des jouets de la norme ASTM F963-96a.



403023.11-U1-11/02