

11501/00436

REKONSTRUCTORS™

BUILD TO BATTLE, REBUILD TO SURVIVE!
CONSTRUIRE POUR COMBATTRE, RECONSTRUIRE POUR SURVIVRE !



Building System
Système De Construction

8+

ZeKorian Fossils™
SABRIX™



SABRIX™

Sabrix is a ZeKorian Fossil resembling a saber tooth tiger.

He was brought to life in a massive energy explosion on Planet ZeKor.

Sabrix is a ruthless leader with tremendously strong fangs and piercing claws. As his PowerCore glows, a strange ooze begins to pump through his body. This ooze enables Sabrix to change into different shapes that help him defend against enemies.

Sabrix also has the ability to launch missiles from his tail.

Sabrix's PowerCore is Permafrost, the ability to trap his enemies in a block of ice when he roars. Sabrix is the ruthless, fearsome and dangerous leader of the ZeKorian Fossil creatures.

Sabrix, est un fossile Zekorian, qui ressemble à un tigre à dents de sabre. Il est né d'une énorme explosion d'énergie sur la planète ZeKor. Sabrix est un chef impitoyable avec des crocs extrêmement forts et des griffes perçantes. Lorsque son PowerCore luit, un magma étrange commence à circuler dans son organisme. Ce magma lui permet de se transformer en différents modes pour l'aider à se défendre contre ses ennemis. Sabrix a aussi la capacité de lancer des missiles de sa queue.

Le PowerCore de Sabrix est la Permafrost, la capacité de figer ses ennemis dans un bloc de glace lorsqu'il rugit. Sabrix est le chef impitoyable, redoutable et dangereux des créatures fossiles Zekorian.



SABRIX, THE LARGEST AND MOST FEROCIOUS OF THE NEWLY REVIVED ZEKORIANS, SLOWLY RISES OUT OF THE RECENTLY FORMED BLAST CRATER. NEARBY, THE XTRACTOR VEKTOR IS UNAWARE OF THE CREATURE'S APPROACH.

SABRIX, LE PLUS IMPOSANT ET LE PLUS FÉROCE DES ZEKORIANS QUI VIENNENT D'ÊTRE RESSUSCITÉS, ÉMERGE LENTEMENT DU CRATÈRE RÉCEMMENT FORMÉ PAR LA FRAPPE. À PROXIMITÉ, L'XTRACTOR VEKTOR NE REMARQUE PAS L'APPROCHE DE LA CRÉATURE.

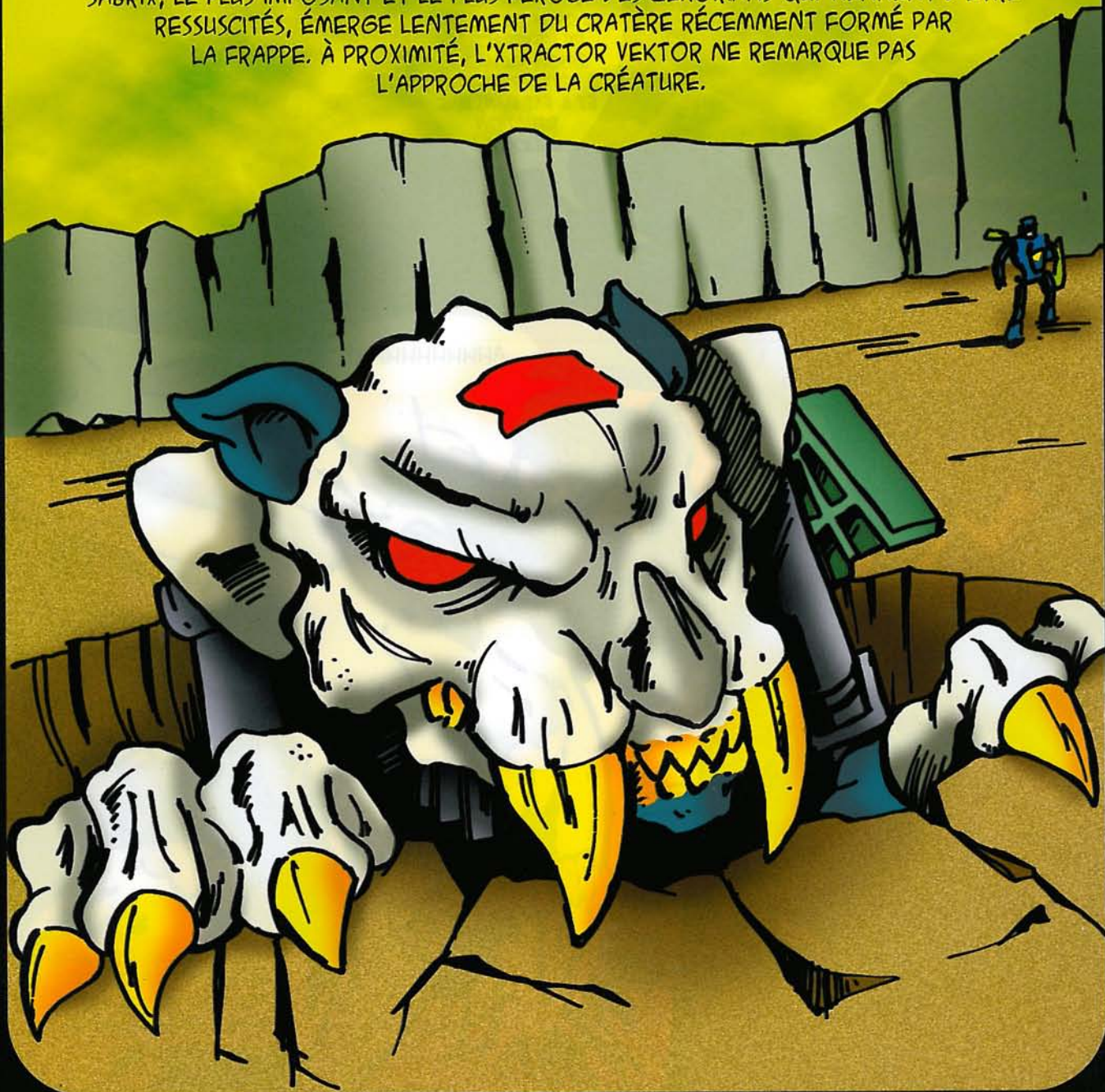



I THINK THAT'S THE EXTRACTOR JASON MICHAELS, I MEAN VEKTOR, AND HE'S IN TROUBLE!
 JE CROIS QU'IL S'AGIT DE L'EXTRACTOR JASON MICHAELS, JE VEUX DIRE VEKTOR, ET IL EST DANS UNE SITUATION DÉLICATE !

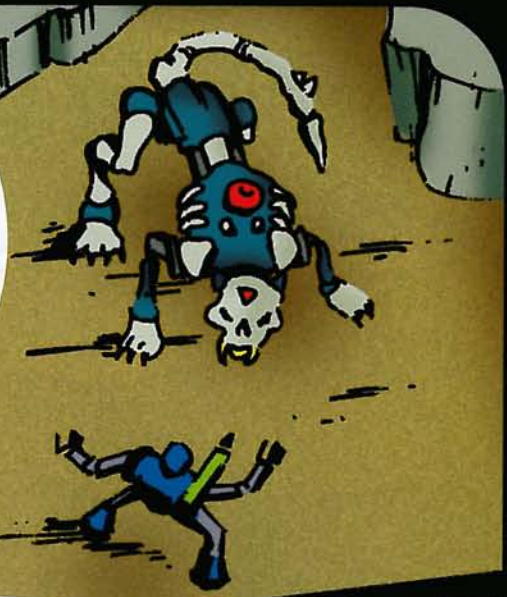

INFERNOSTRIKE, CRUISING OVERHEAD, NOTICES THAT VEKTOR IS NOW TRAPPED BY SABRIX.

INFERNOSTRIKE, SURVOLANT LES LIEUX, REMARQUE QUE VEKTOR EST MAINTENANT PIÉGÉ PAR SABRIX.

AHHHHHHHHH!



KKKRRRRRAAAKKKK!

SABRIX CLAMPS HIS POWERFUL JAWS DOWN ON VEKTOR. SABRIX SAISIT VEKTOR ENTRE SES MÂCHOIRES PUISSANTES.

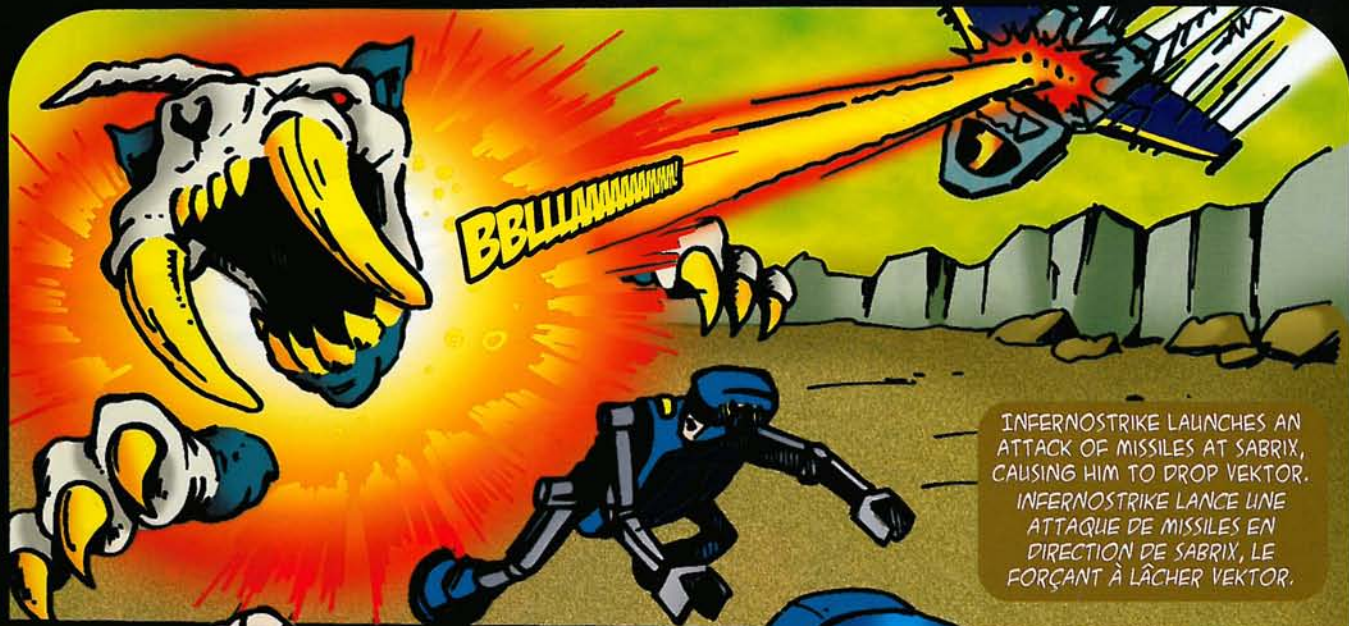

INFERNOSTRIKE LAUNCHES AN
ATTACK OF MISSILES AT SABRIX,
CAUSING HIM TO DROP VEKTOR.
INFERNOSTRIKE LANCE UNE
ATTAQUE DE MISSILES EN
DIRECTION DE SABRIX, LE
FORÇANT À LÂCHER VEKTOR.



AS VEKTOR TRIES TO ESCAPE,
SABRIX USES HIS PERMAFROST
POWERCORE TO FREEZE
VEKTOR.

ALORS QUE VEKTOR
TENTE DE S'ENFUIR, SABRIX
USE DE SON PERMAFROST
POWERCORE POUR FIGER
VEKTOR DANS LA GLACE.

AFTER TRAPPING VEKTOR, SABRIX TURNS HIS ATTENTION TO INFERNOSTRIKE.
VEKTOR UNE FOIS PRIS AU PIÈGE, SABRIX SE TOURNE VERS INFERNOSTRIKE.

FFFSSHHHH!

BEFORE INFERNOSTRIKE
CAN REACT, SABRIX LAUNCHES
A MISSILE AT HIM.
AVANT QUE INFERNOSTRIKE
PUISSE RÉAGIR, SABRIX LANCE UN
MISSILE DANS SA DIRECTION.

AS HE AVOIDS SABRIX'S MISSILE,
INFERNOSTRIKE USES HIS
PYROTECH POWERCORE TO
THAW OUT VEKTOR.

ESQUIVANT LE MISSILE DE SABRIX,
INFERNOSTRIKE USE DE SON
PYROTECH POWERCORE POUR
LIBÉRER VEKTOR DE LA GLACE.

GET OUT OF HERE
VEKTOR, I'LL HANDLE HIM!
SORS DE LÀ VEKTOR, JE
M'OCCUPE DE LUI!

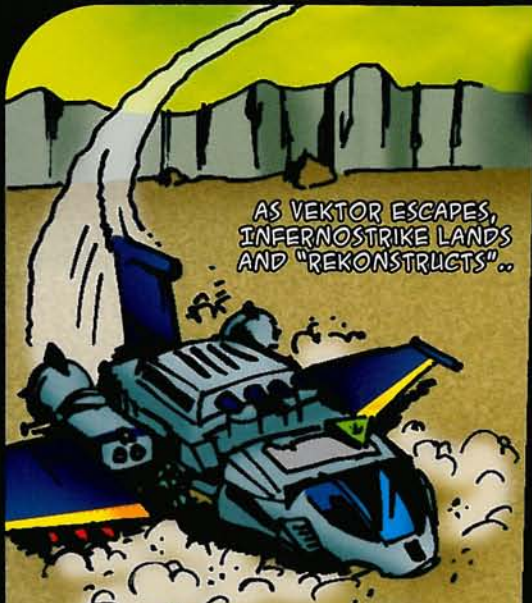

AS VEKTOR ESCAPES,
INFERNOSTRIKE LANDS
AND "REKONSTRUCTS"...



WATCHING THIS, SABRIX'S Ooze
BEGINS TO PUMP, CAUSING HIM
TO "REKONSTRUCT" INTO
BATTLE MODE.

EN VOYANT CELA, LE PLASMA
DE SABRIX S'ACTIVE, LE FAISANT
SE «REKONSTRUCT» EN MODE
DE COMBAT.

PENDANT QUE VEKTOR S'ÉCHAPPE,
INFERNOSTRIKE ATTERIT ET SE
«REKONSTRUCT»...



SABRIX LEAPS RIGHT AT
INFERNOSTRIKE,
CATCHING HIM
OFF GUARD.

SABRIX BONDIT SUR
INFERNOSTRIKE, LE
PRENANT À DÉPOURVU.

Attack Mode

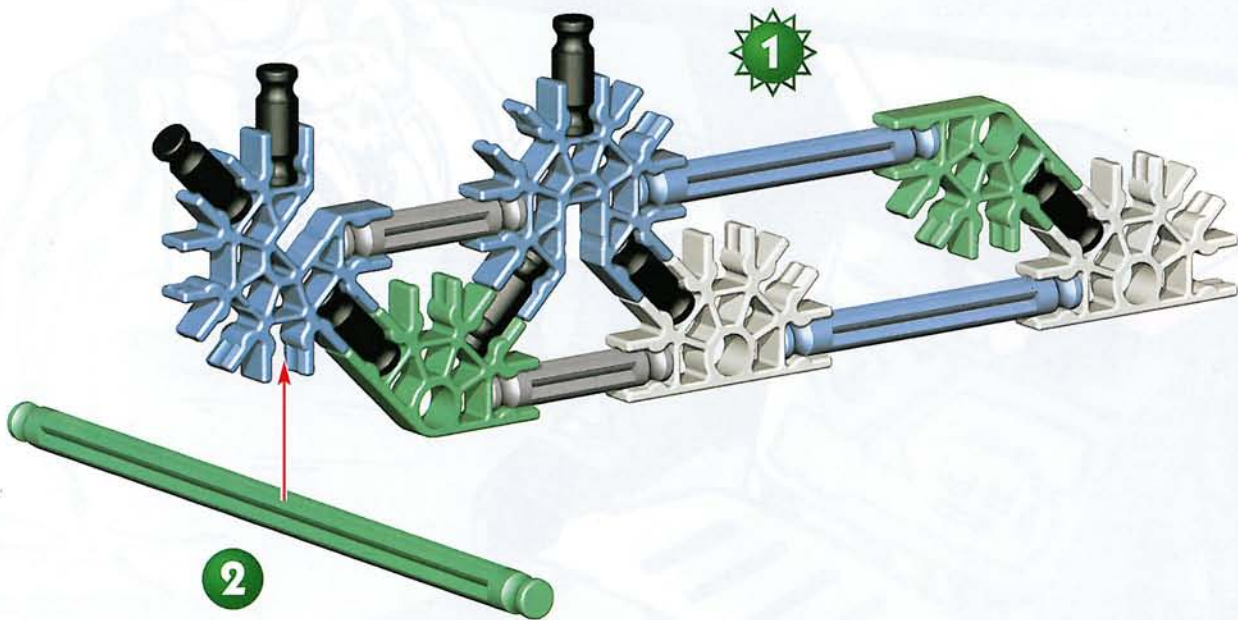

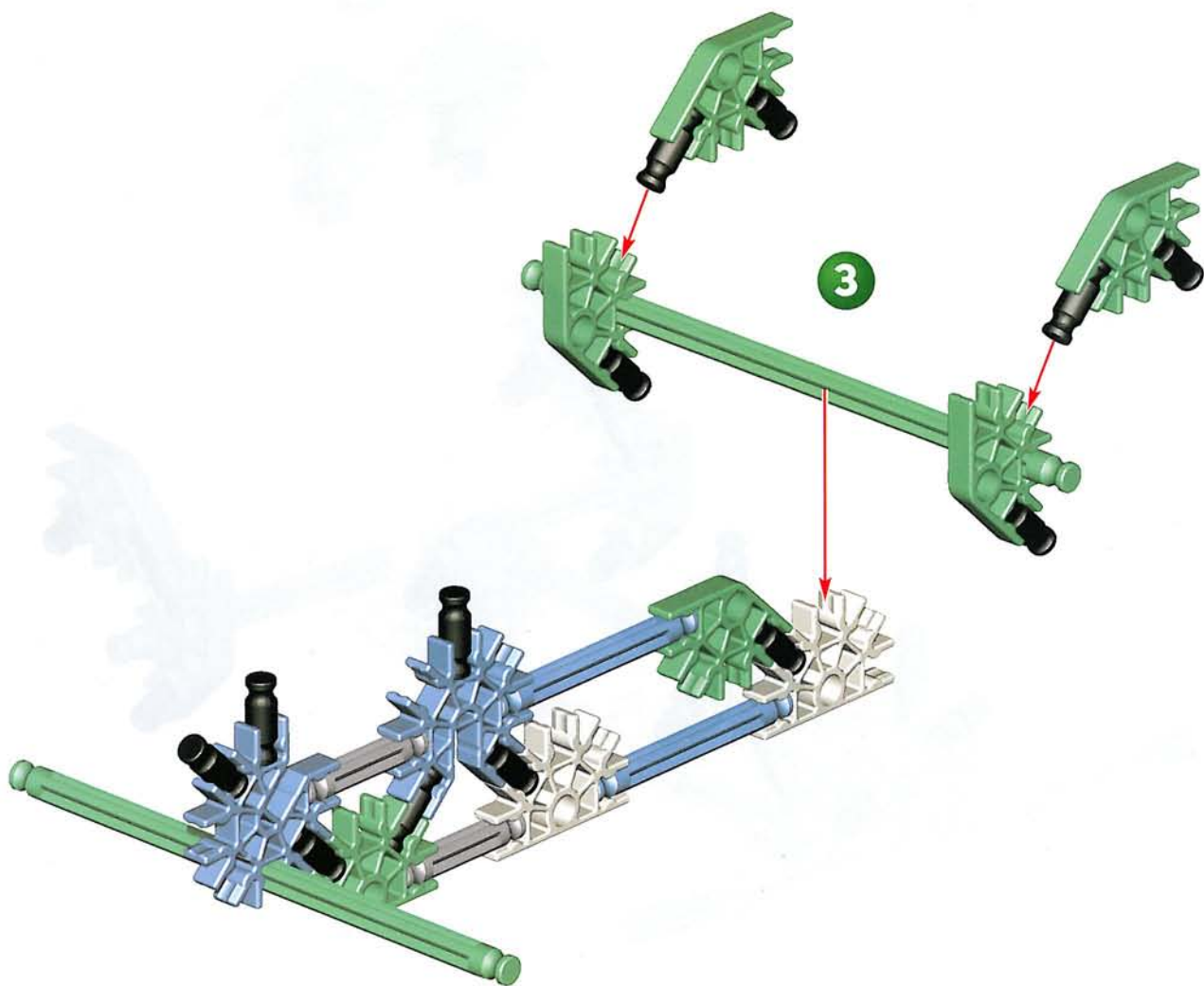

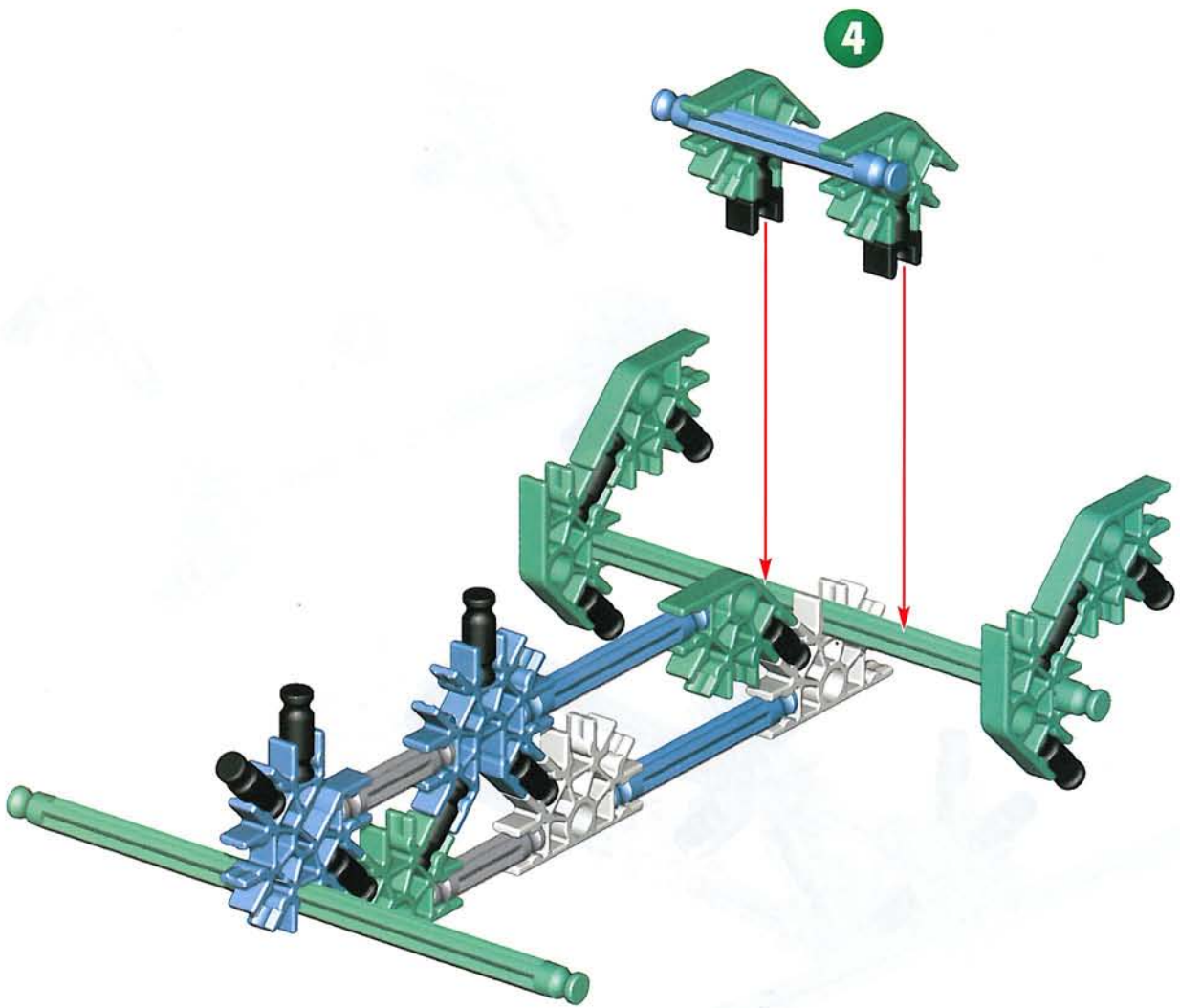

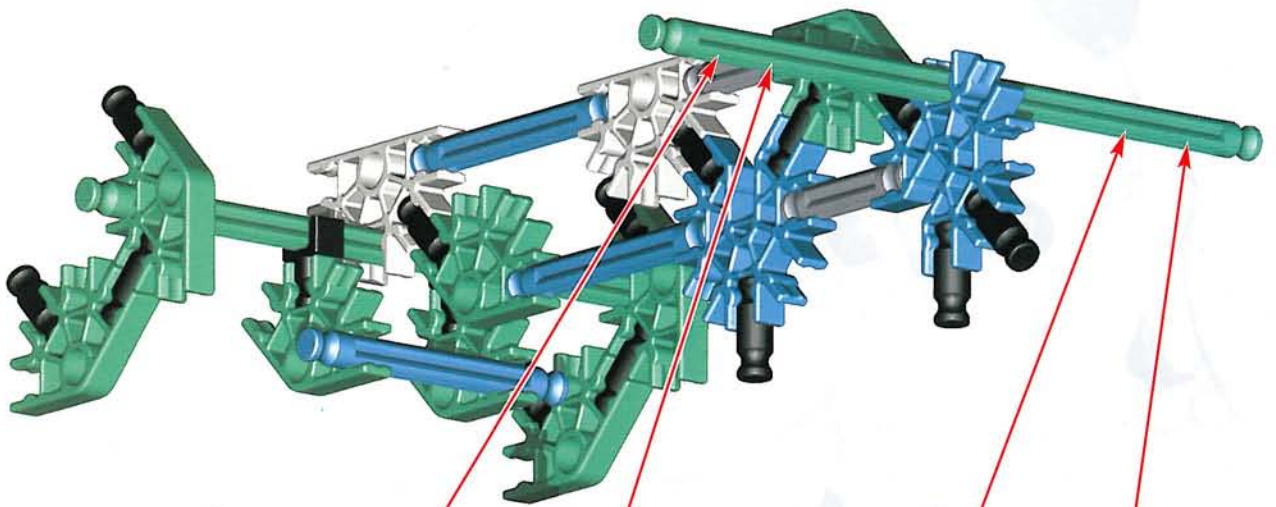

9

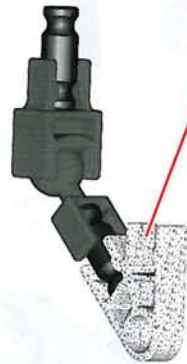

5

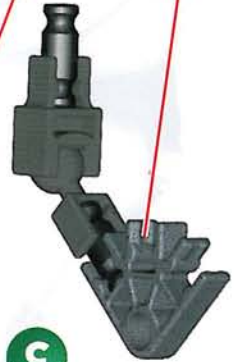

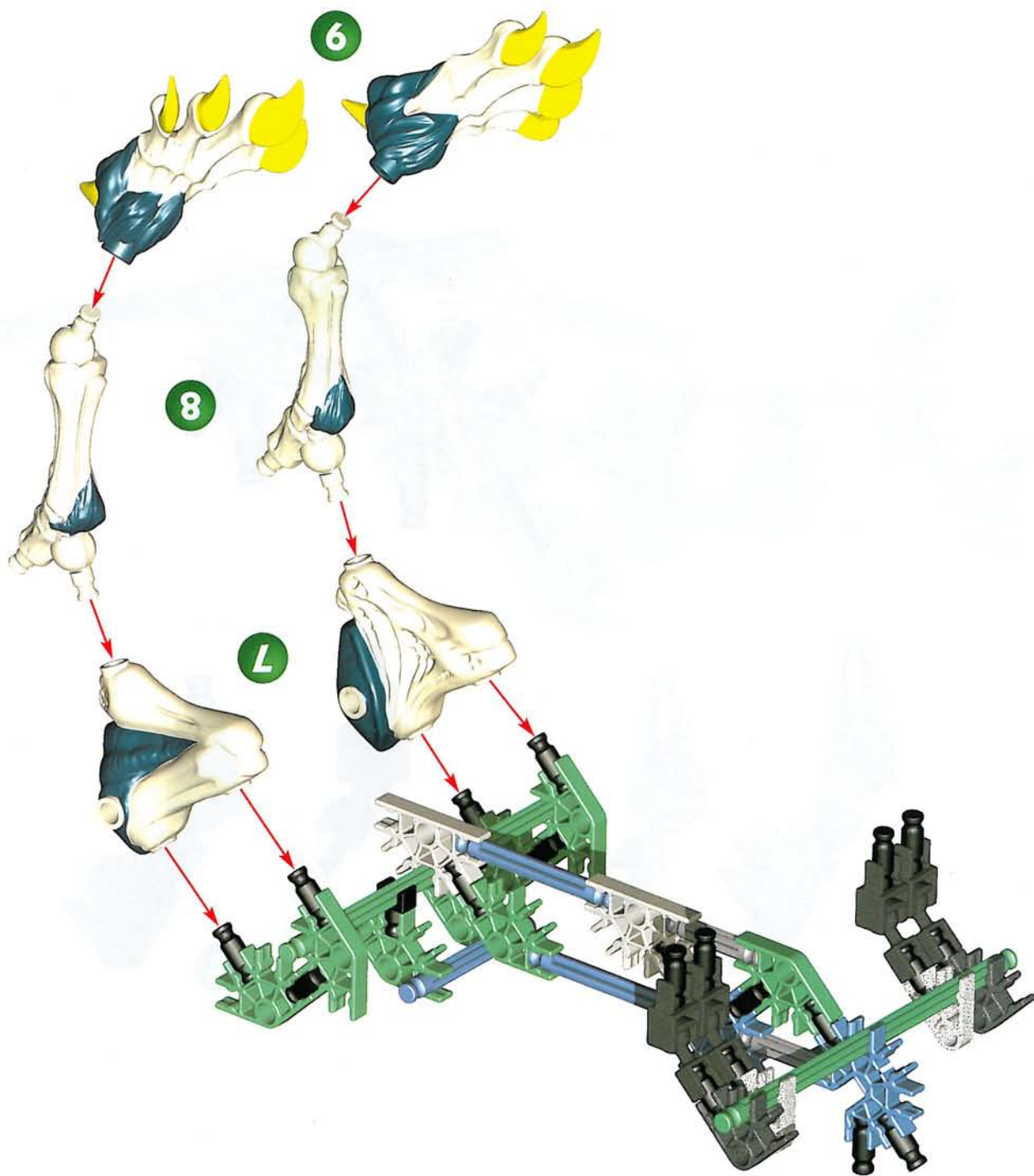

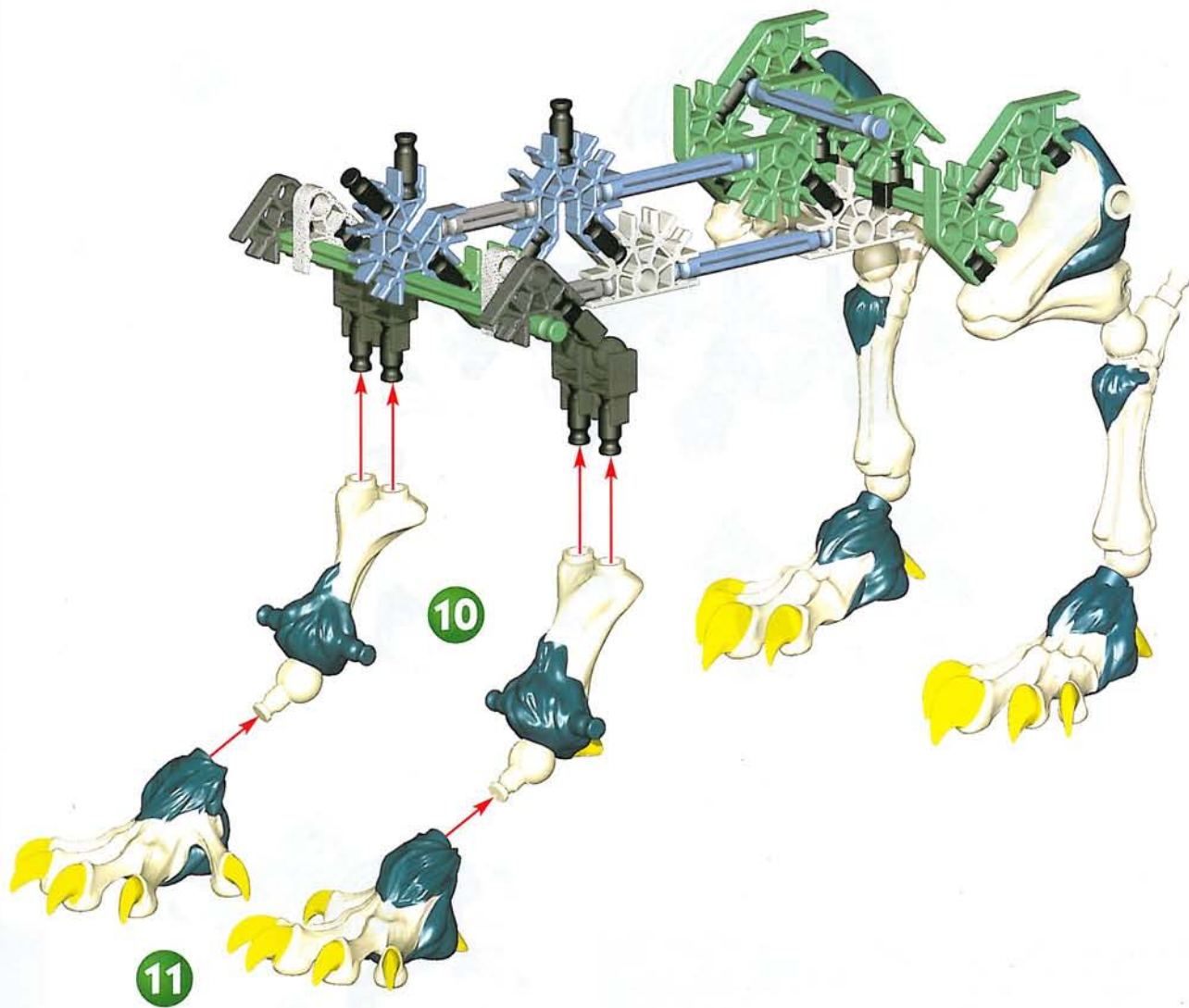

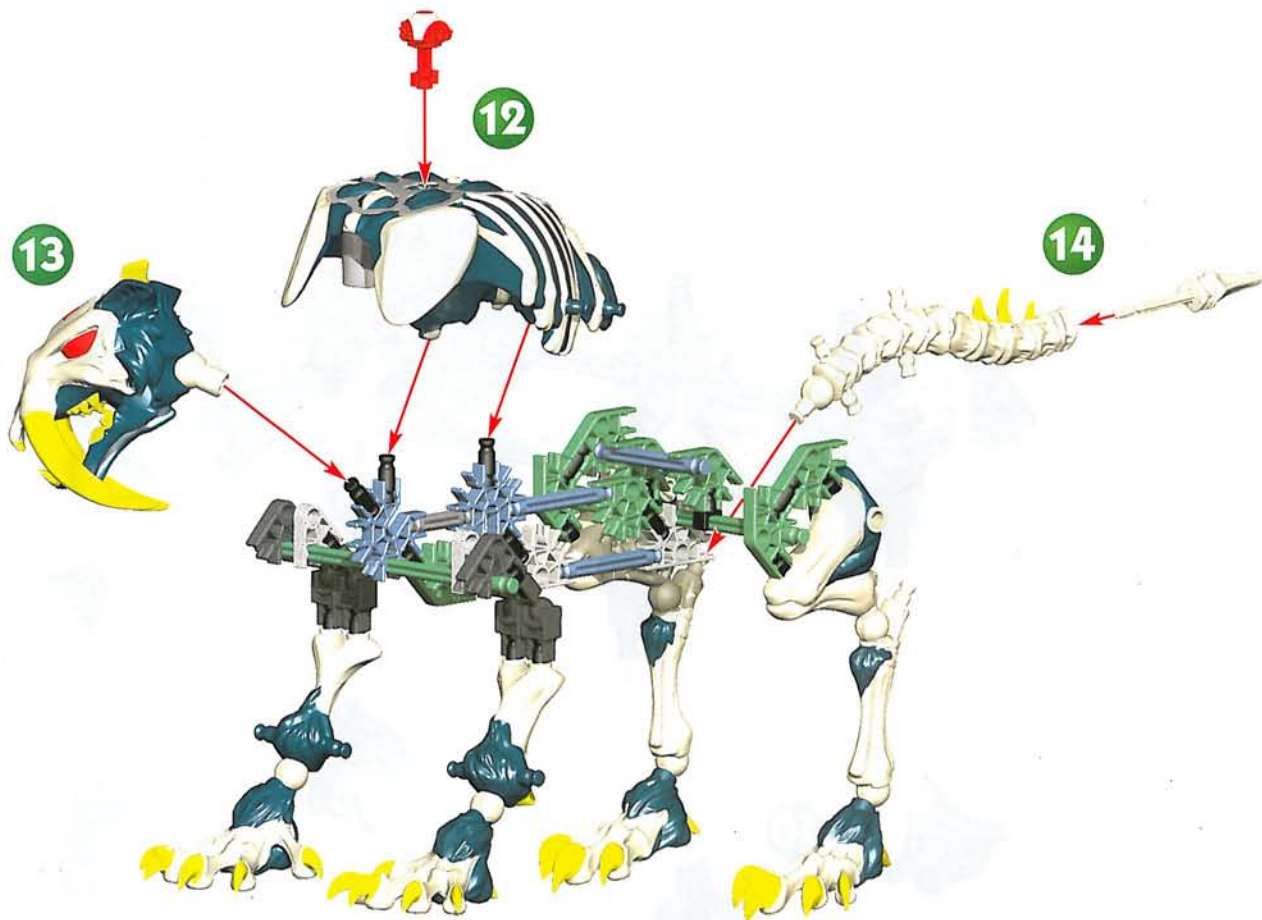

WITH INFERNOSTRIKE PINNED DOWN, SABRIX CLAMPS DOWN ON INFERNOSTRIKE'S POWERCORE, RIPPING IT FREE.
INFERNOSTRIKE IMMOBILISÉ, SABRIX SAISIT LE POWERCORE DE INFERNOSTRIKE ENTRE SES MÂCHOIRES, L'ARRACHANT.

NOOOOO!
NOOOOON!

AFTER REMOVING INFERNOSTRIKE'S POWERCORE, SABRIX USES HIS PERMAFROST POWERCORE TO FREEZE HIS ENEMY IN PLACE.
UNE FOIS LE POWERCORE D'INFERNOSTRIKE SOUSTRAIT, SABRIX USE DE SON PERMAFROST POWERCORE POUR FIGER L'ENNEMI DANS LA GLACE.



Scout Mode

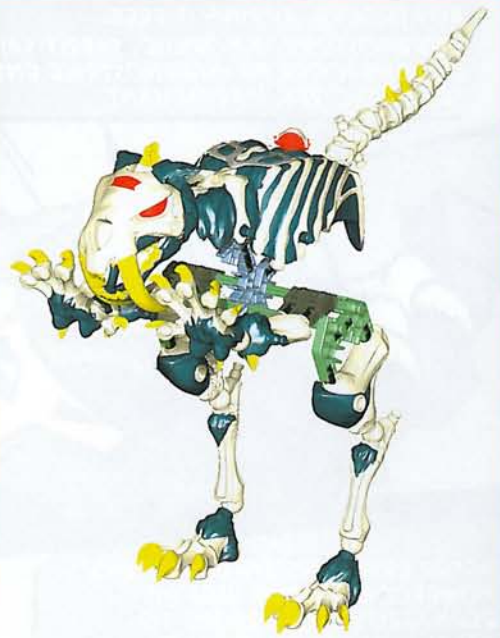

1

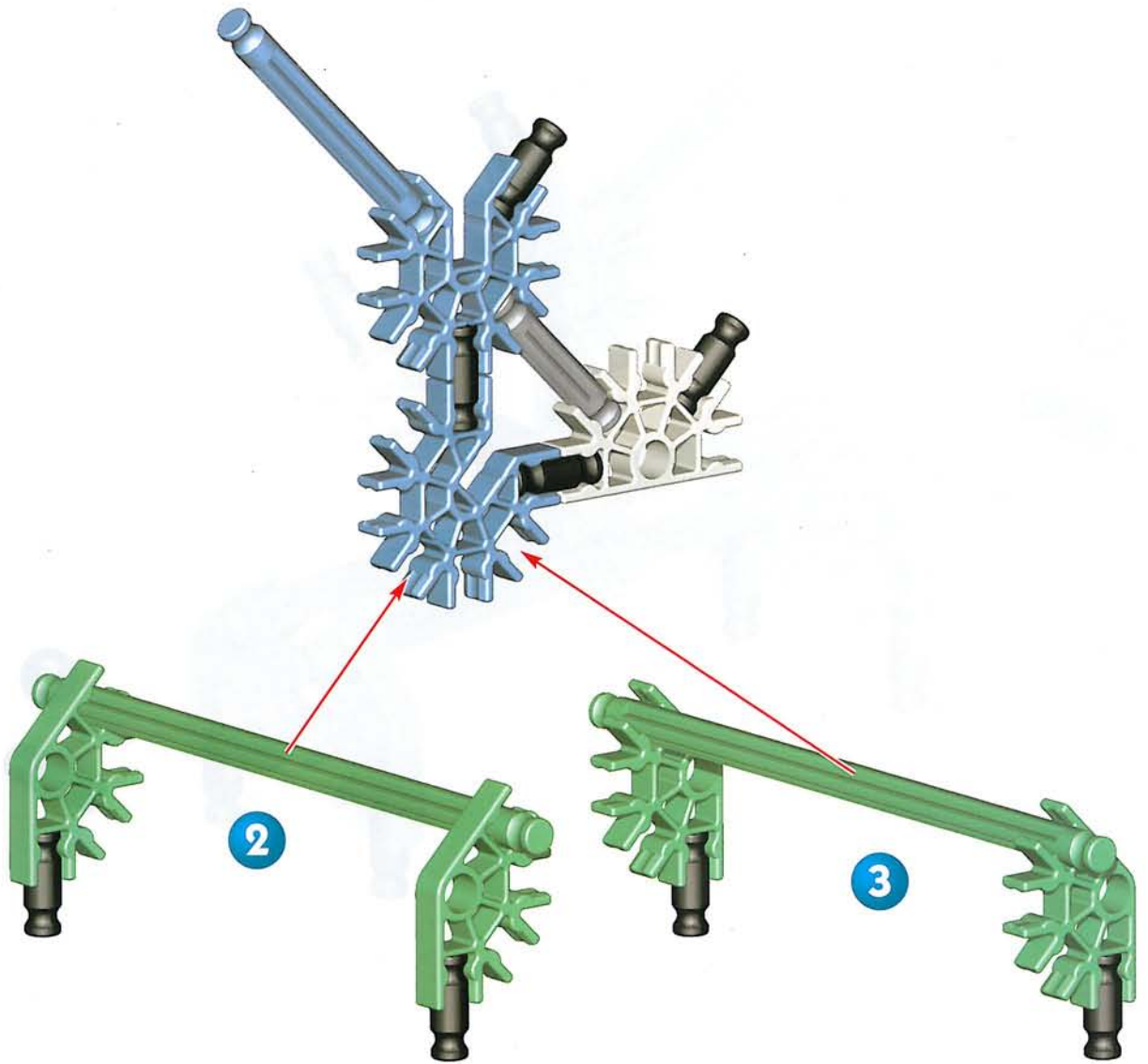

4

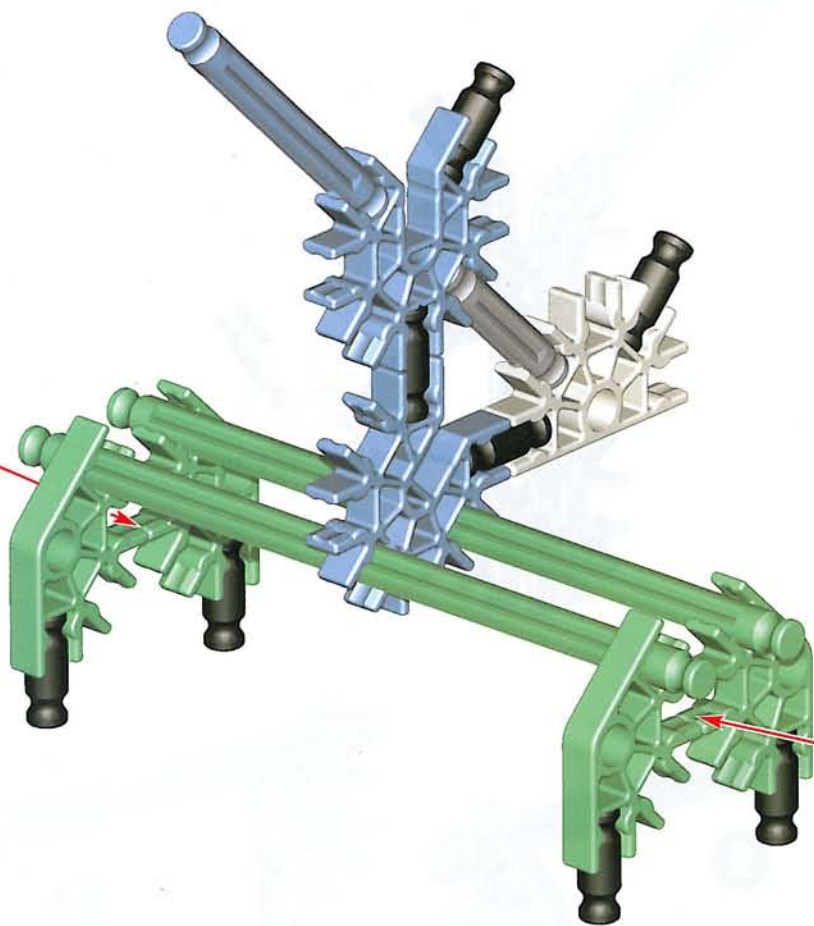

5



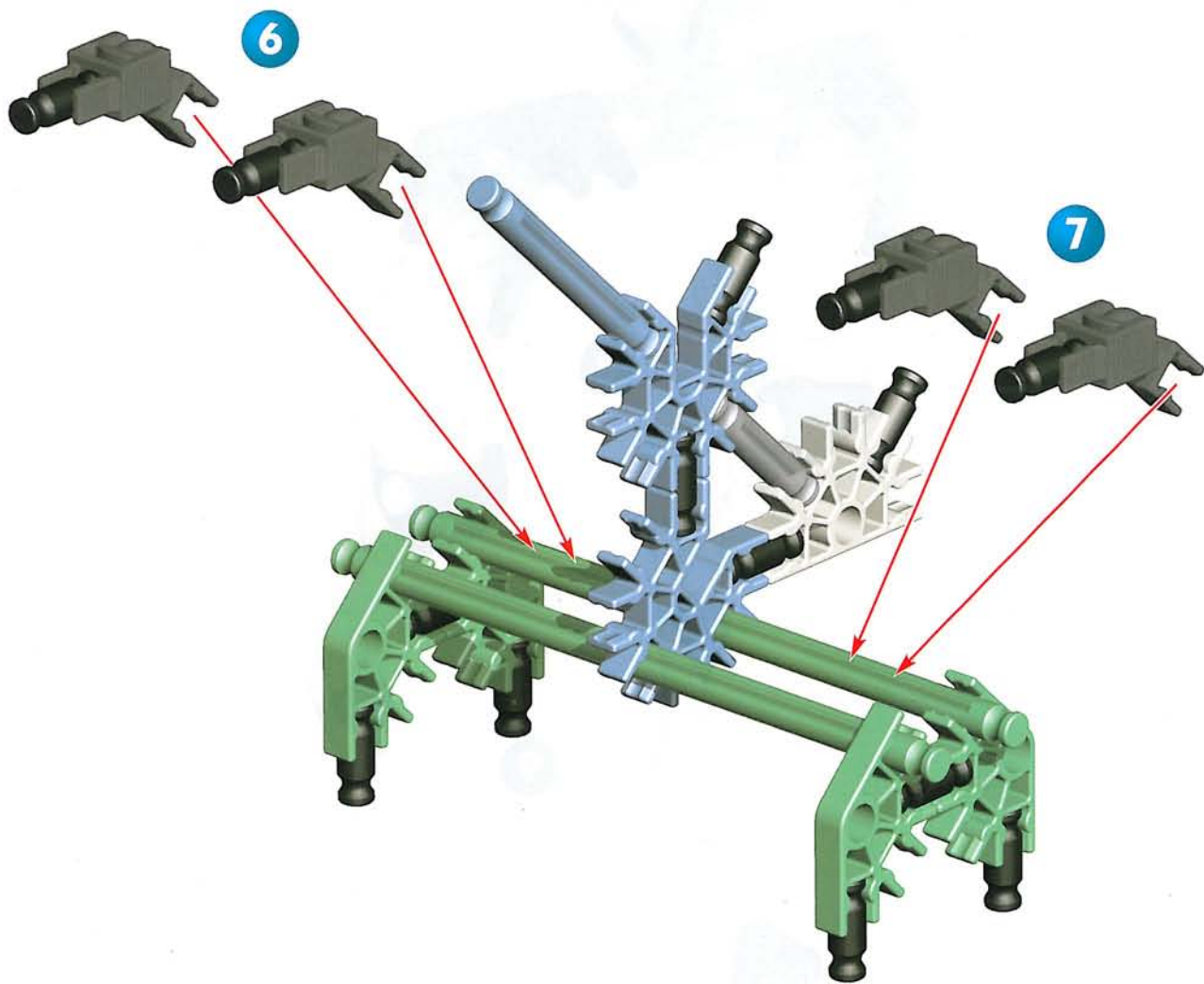

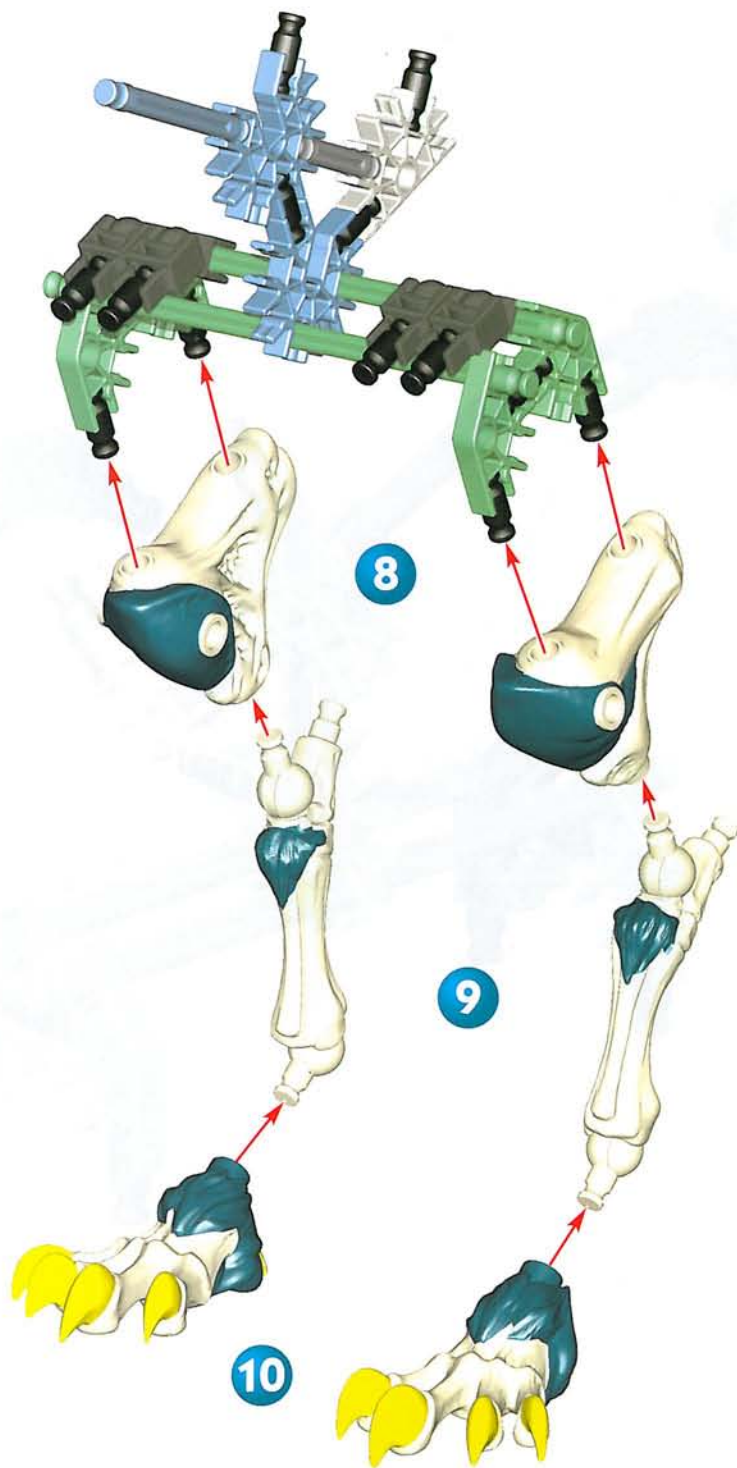

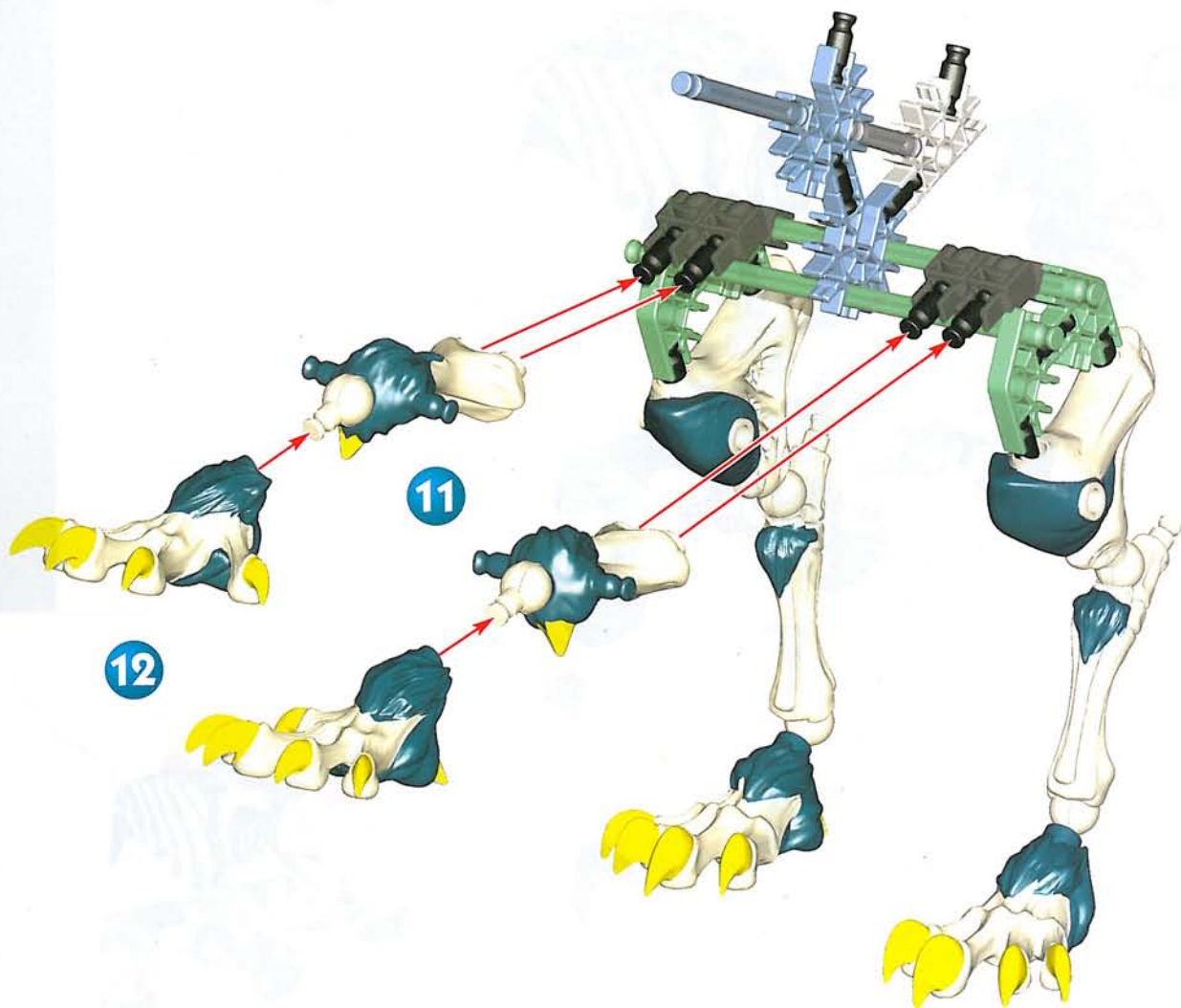

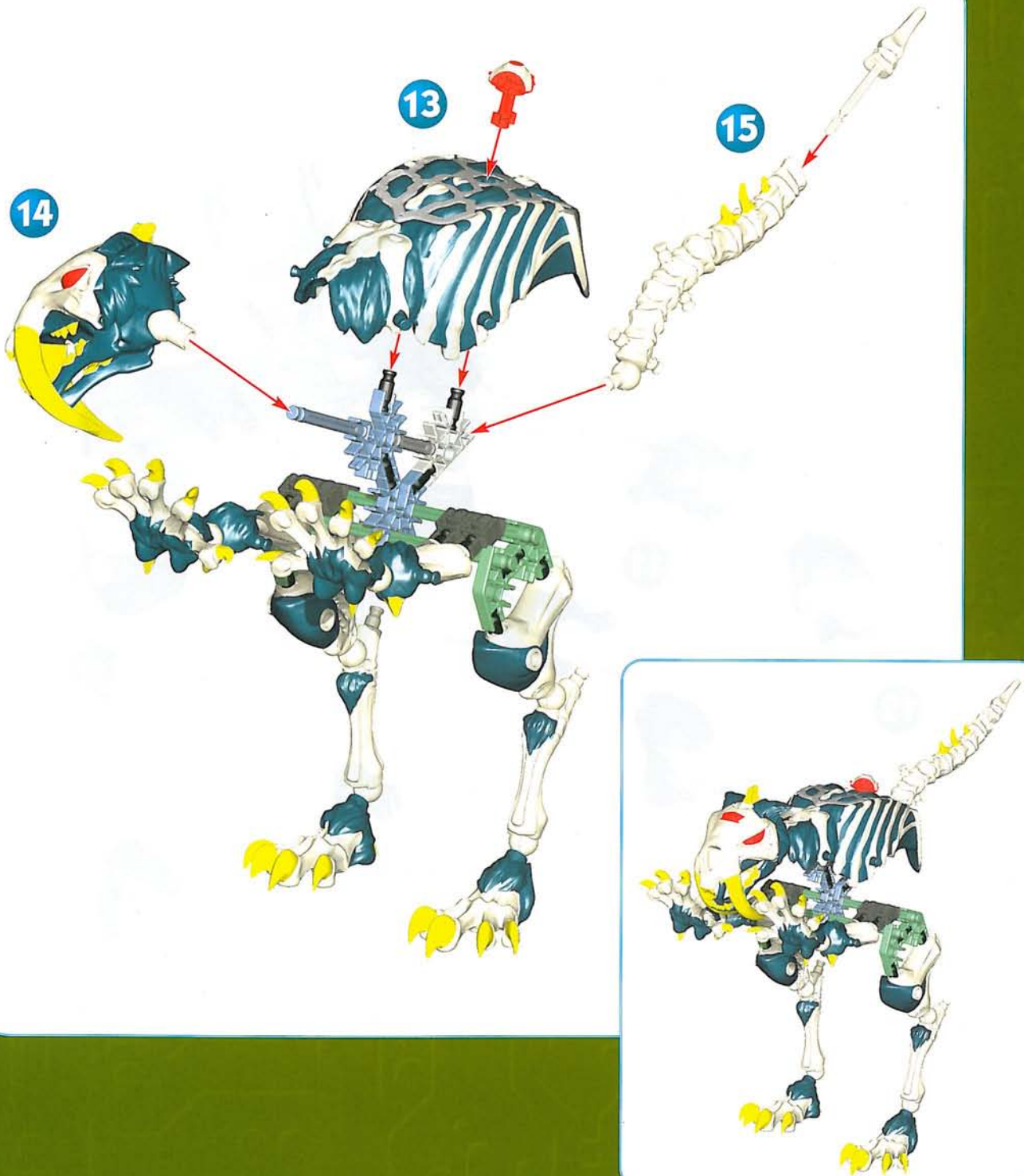



WITH INFERNOSTRIKE OUT OF THE WAY, SABRIX,
OOZE PUMPING, "RECONSTRUCTS" INTO HIS NEW MODE.
INFERNOSTRIKE NEUTRALISÉ, SABRIX, SE «RECONSTRUCT»
DANS SON NOUVEAU MODE.

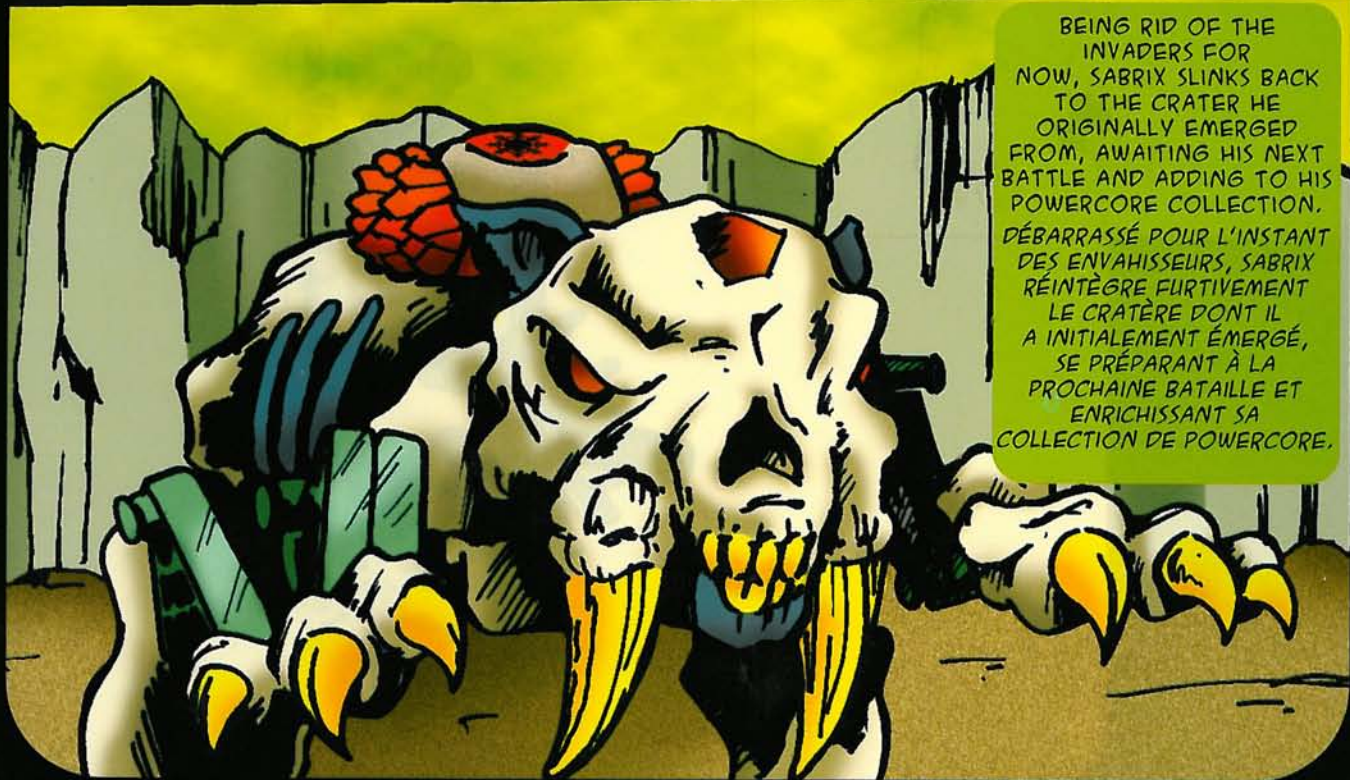

BEING RID OF THE
INVADERS FOR
NOW, SABRIX SLINKS BACK
TO THE CRATER HE
ORIGINALLY EMERGED
FROM, AWAITING HIS NEXT
BATTLE AND ADDING TO HIS
POWERCORE COLLECTION.
DÉBARRASSÉ POUR L'INSTANT
DES ENVAHISSEURS,
SABRIX RÉINTÈGRE FURTIVEMENT
LE CRATÈRE DONT IL
A INITIALEMENT ÉMÉRGÉ,
SE PRÉPARANT À LA
PROCHAINE BATAILLE ET
ENRICHISSANT SA
COLLECTION DE POWERCORE.

Battle Mode

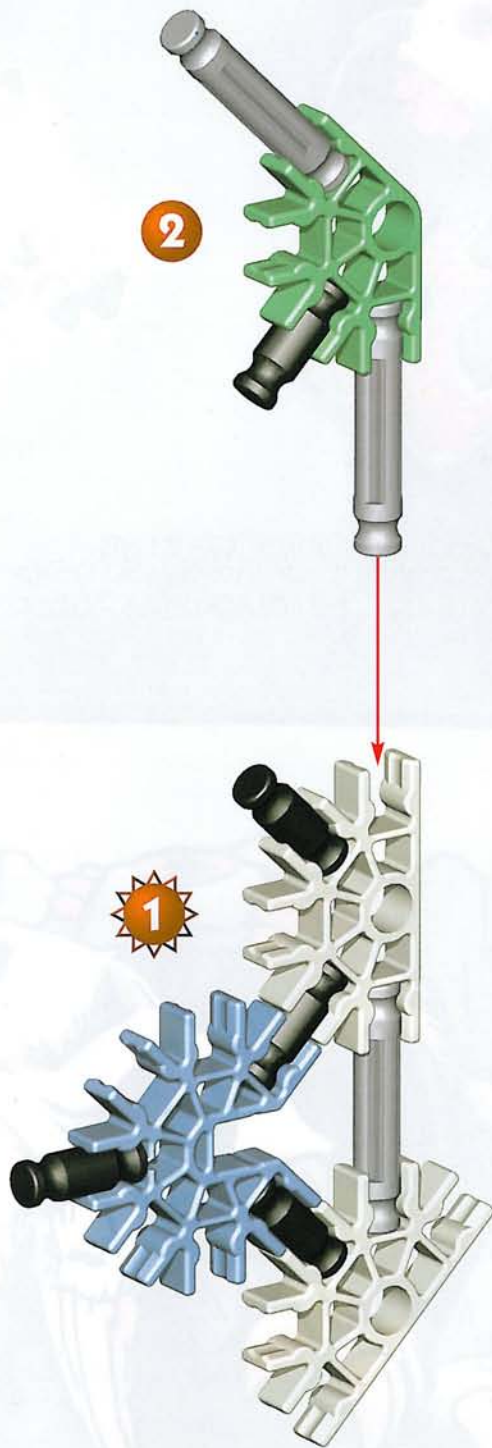

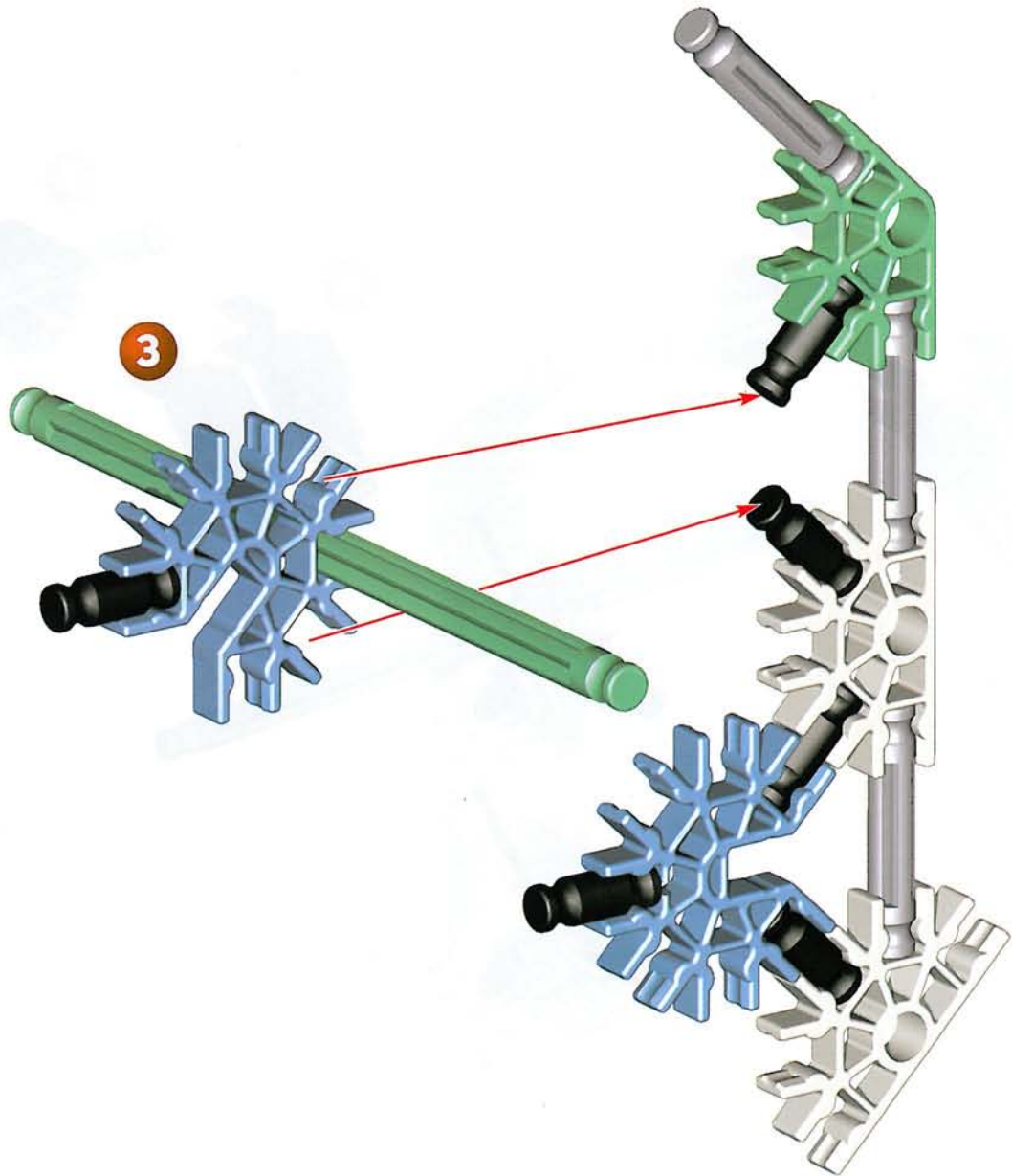

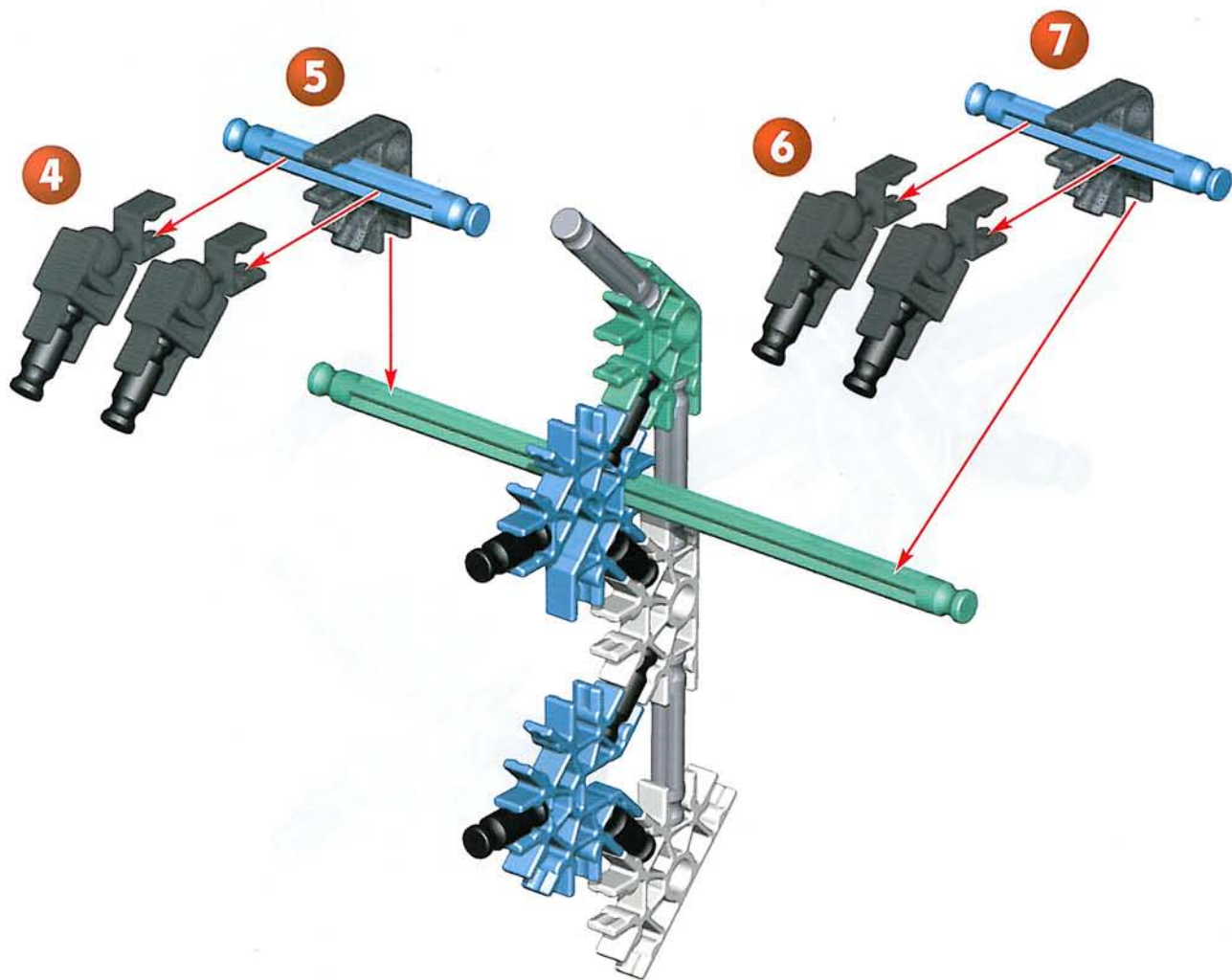

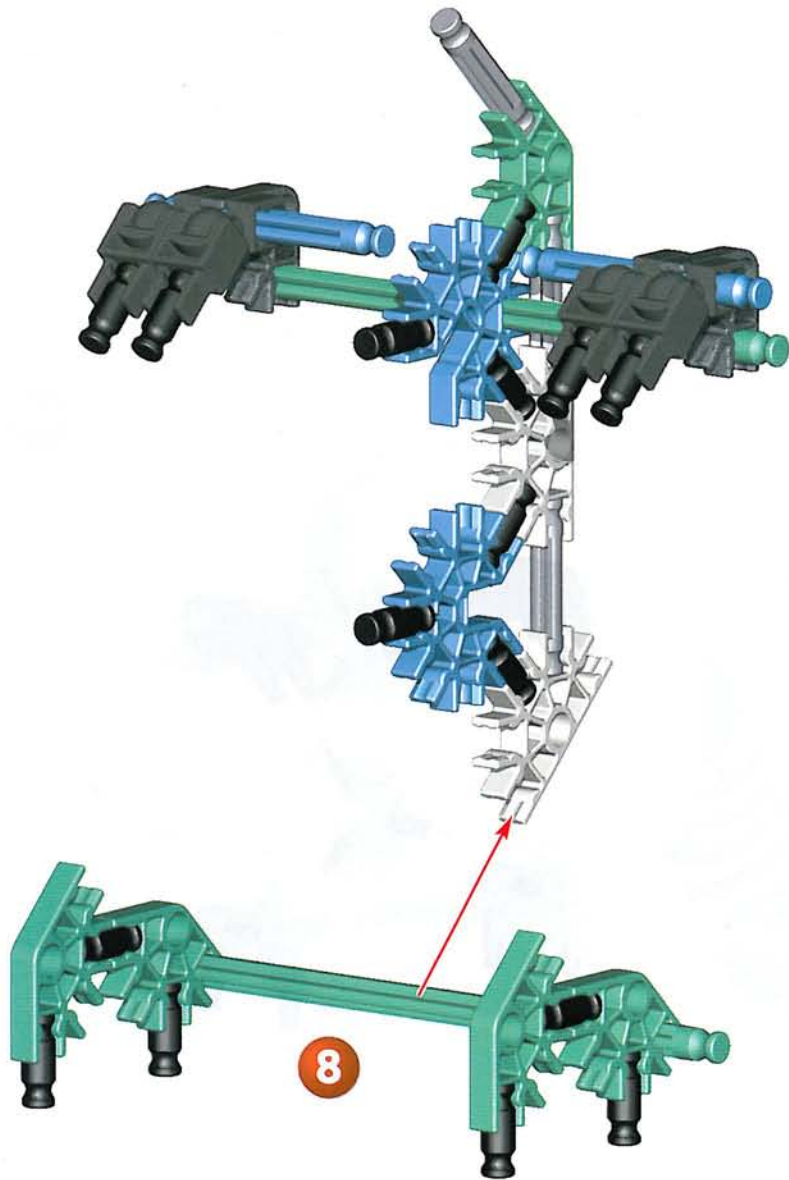

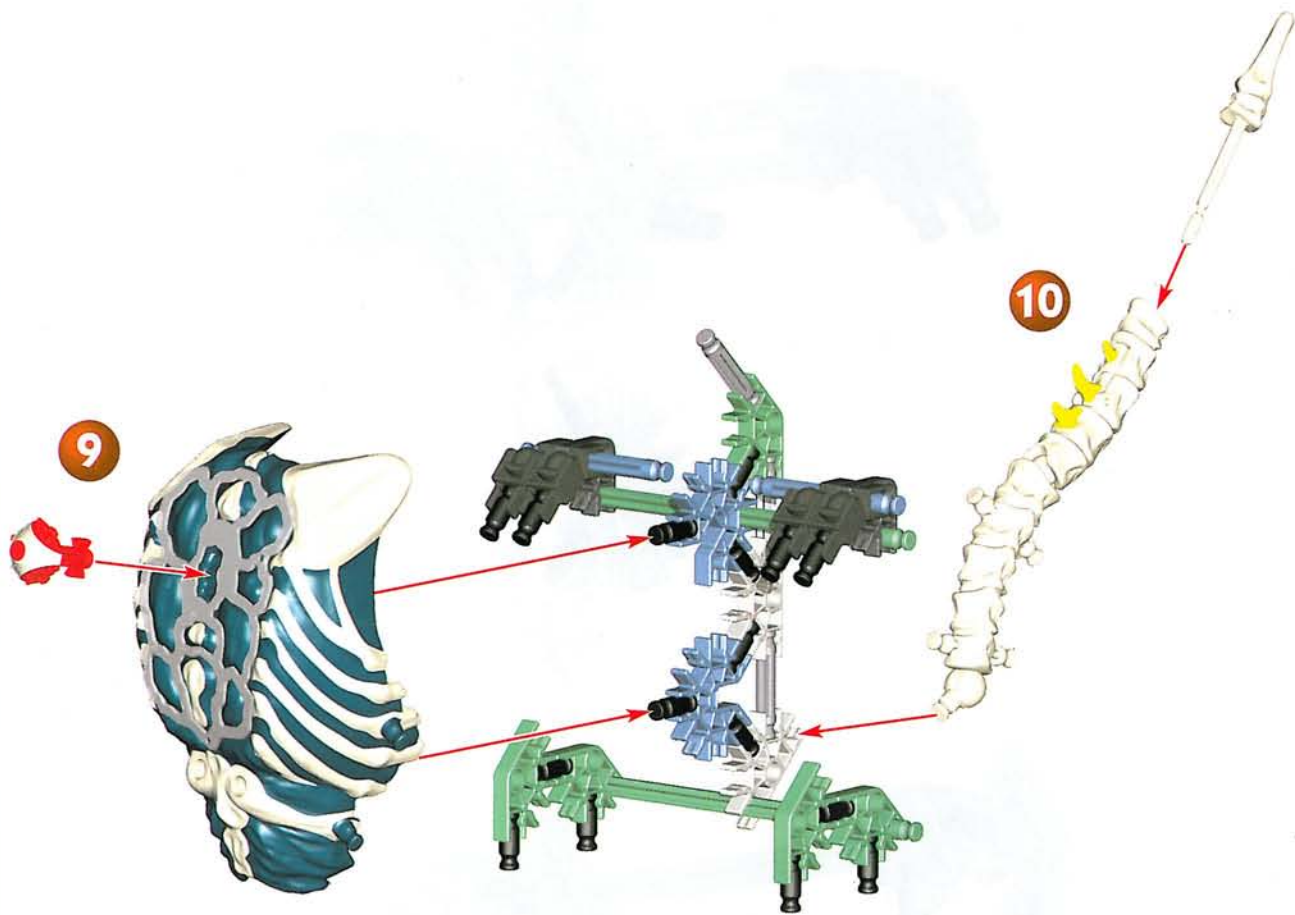

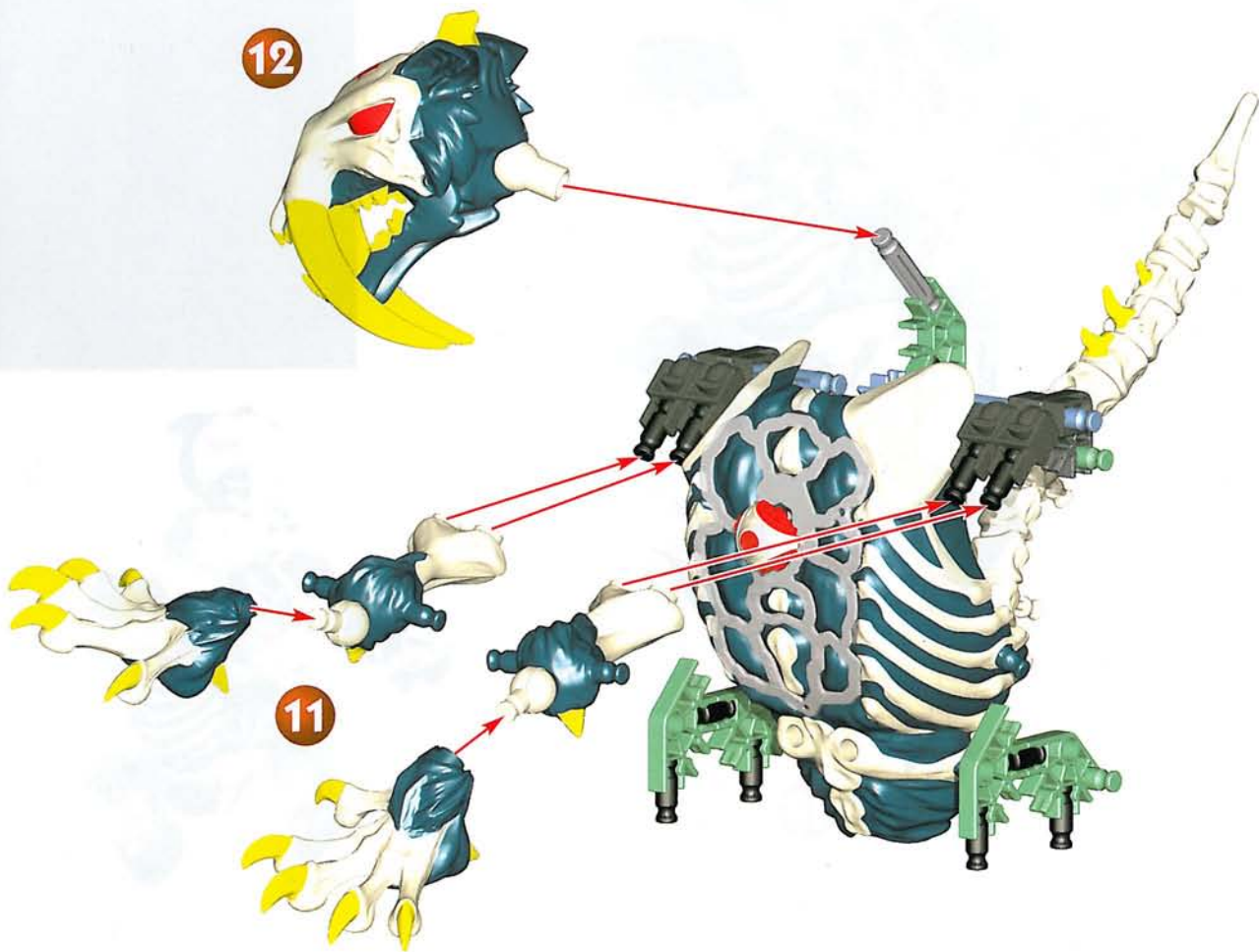

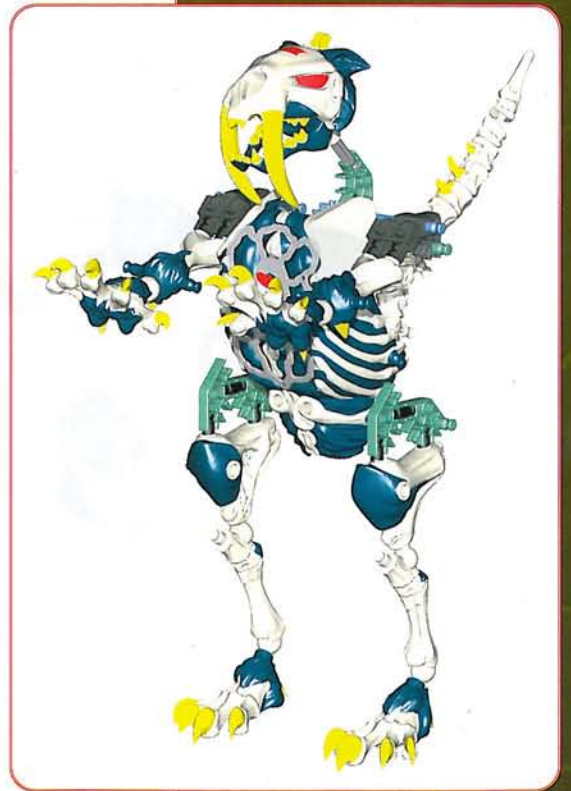
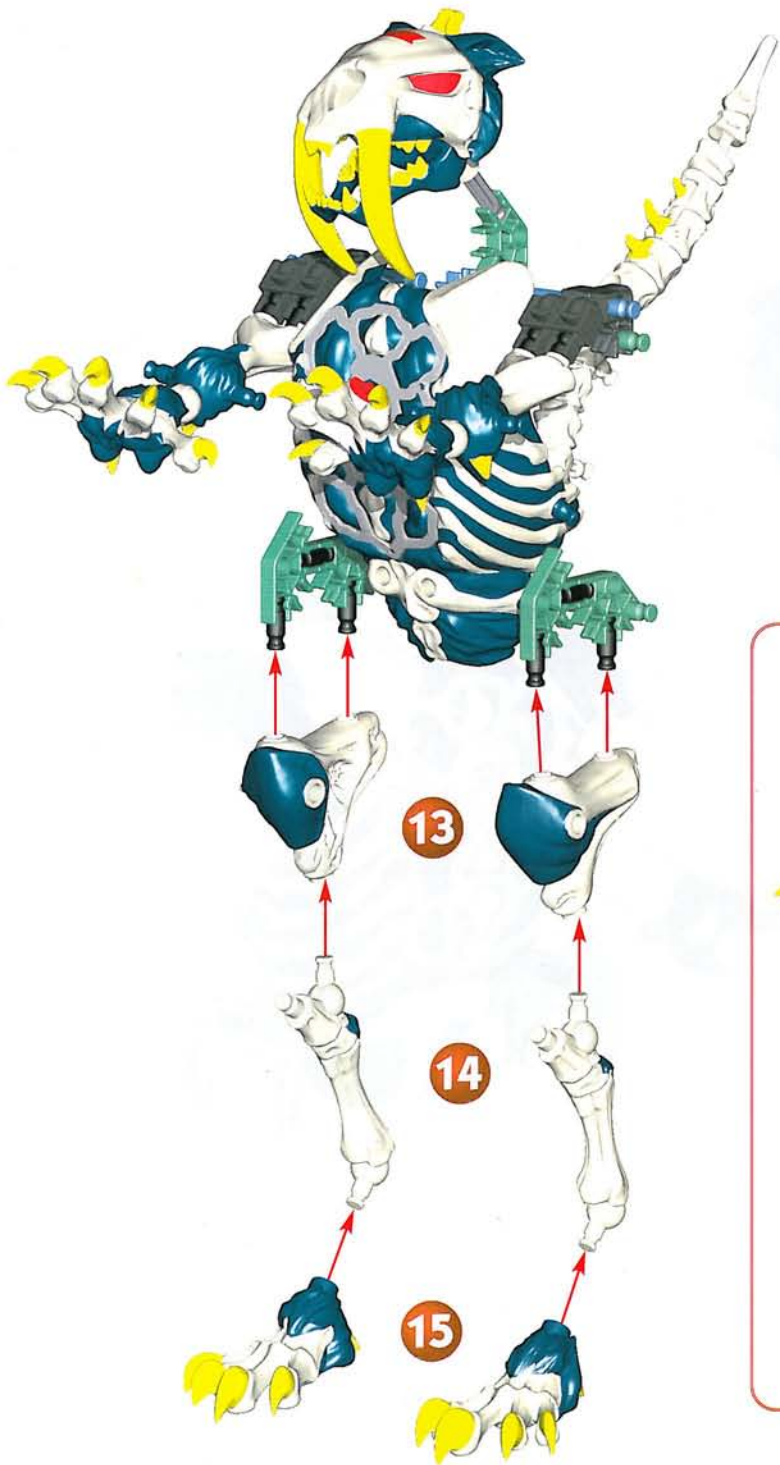

SPECIAL FEATURES *ATTRIBUTS SPÉCIAUX*

PRESS BUTTON
TO FIRE MISSILES

*APPUYE SUR LE
BOUTON POUR
PROPULSER
LES MISSILES*

PUMPING OOZE!
*POMPANT DU
MAGMA !*

PERMAFROST POWERCORE™

EYES LIGHT UP!
LES YEUX S'ALLUMENT !



MISSILE FIRING TAIL!
*QUEUE QUI LANCE
DES MISSILES !*

JAW CHOMPING ACTION!
LES MÂCHOIRES CLAQUENT !

Caution: Do not launch in the direction of people, animals, or walls; you could cause injury or damage. Never attempt to launch any projectiles other than K'NEX missiles.

Mise en garde : ne pas lancer en direction de personnes, d'animaux, ou de murs pour éviter le risque de blesser quelqu'un ou de provoquer des dégâts. Ne jamais tenter de lancer d'autres projectiles que les missiles K'NEX.

Opgelet: Niet lanceren in de richting van mensen, dieren of muren; je zou letsel of schade kunnen veroorzaken. Nooit proberen om andere projectielen dan K'NEX raketten te lanceren.



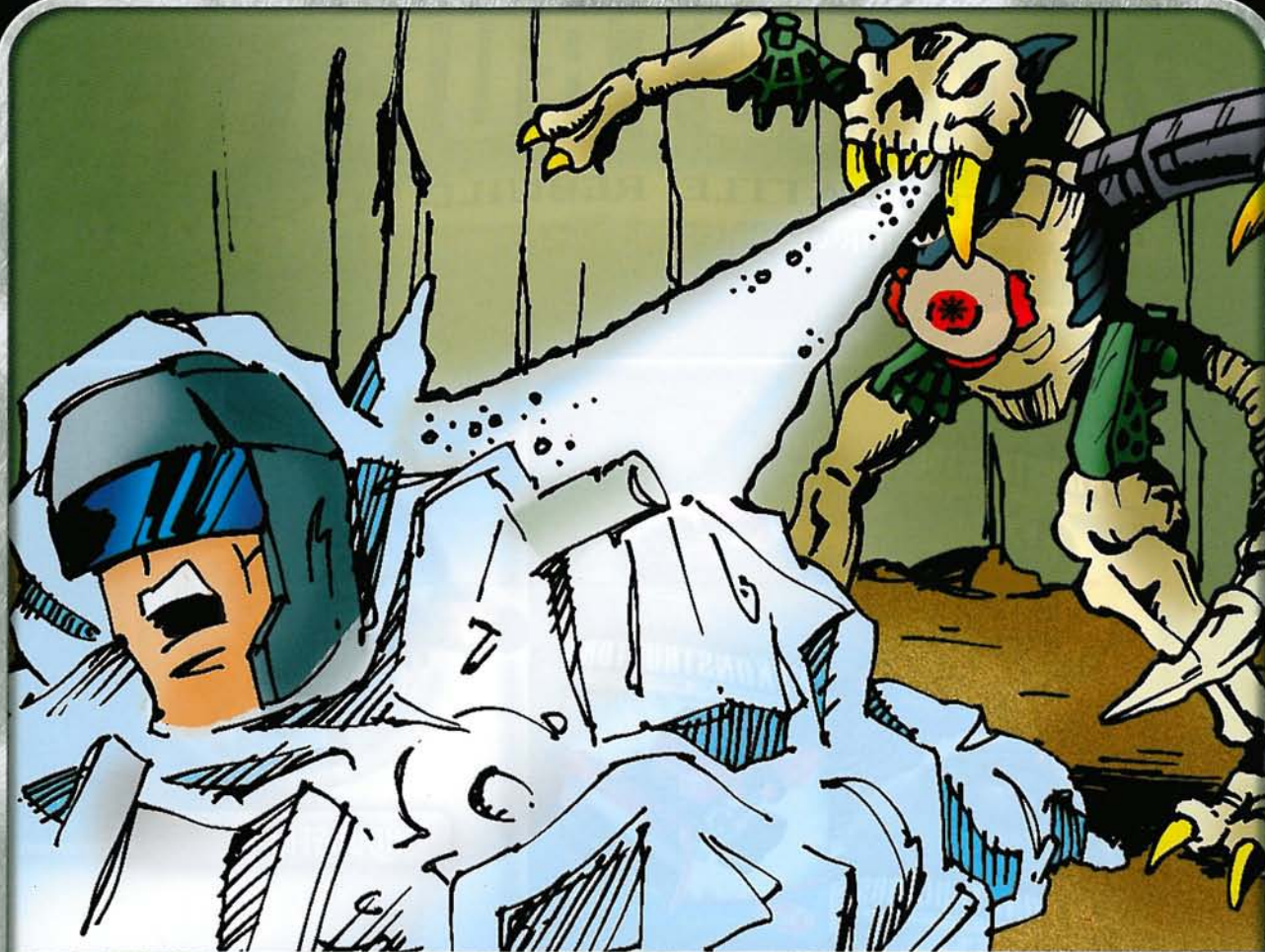

REKONSTRUCTORS.com

Get the Story, Play the Game!
Connais l'histoire, Joue le jeu !



REKONSTRUCTORS.COM

REKONSTRUCTORS™

BUILD TO BATTLE, REBUILD TO SURVIVE!
CONSTRUIRE POUR COMBATTRE, RECONSTRUIRE POUR SURVIVRE!



XTRACTORS™



AQUASTRIKE™



CARNIX™

Collect 'em All! Collectionne-les tous!

REKONSTRUCTORS STRIKEFORCE™



CYCLOSTRIKE™



TERRASTRIKE™



INFERNOSTRIKE™

ZEKORIAN FOSSILS™



TALIX™



LUPIX™



SABRIX™



©2004 K'NEX Industries, Inc. P.O. Box 700 Hatfield, PA 19440-0700



US 1-800-KID-KNEX US/Canada only (English only)

GB 00800-22427276 UK/Ireland only

F E D NL 001-215-996-4823



US Consumer Services
K'NEX Industries, Inc.
P.O. Box 700
Hatfield, PA 19440-0700



GB K'NEX
Newport Consumer Services
Hasbro UK Ltd., Caswell Way
Newport, Gwent NP9 0YH



www.knex.com



email@knex.com



WARNING:

CHOKING HAZARD- Small parts.
Not for children under 3 years.



AVERTISSEMENT:

DANGER D'ÉTOUFFEMENT- Pièces de petite
taille Ne pas donner aux enfants de moins de 3 ans.



WAARSCHUWING:

VERSTIKKINGSGEVAAR- In verband met kleine
onderdelen niet geschikt voor kinderen tot 3 jaar.

Printed in China
Imprimerie aux China

Product and colors may vary. Models can be built one at a time. K'NEX is a registered trademark of K'NEX Industries, Inc.
Le produit et les couleurs peuvent varier. La plupart des modèles peuvent être construits un à la fois.
K'NEX est une marque déposée de K'NEX Industries, Inc.

Manufactured under U.S. Patents/Fabriqué sous brevets américains 5,061,219; 5,137,486; 5,199,919; 6,460,572.
Other U.S. and foreign patents pending. Autres brevets américains et étrangers en instance.

Conforms to the Requirements of ASTM Standard Consumer Safety Specification on Toy Safety, F963-96a.
Conforme aux spécifications de sécurité du consommateur sur la sécurité des jouets
de la norme ASTM F963-96a.

Get the Story, Play the Game!
Lis l'histoire, joue le jeu!

REKONSTRUCTORS.com



404420.11-U1-12/03