

10838/48341

REKONSTRUCTORS™

ONE BATTLE... 3 WAYS TO SURVIVE!
UNE BATAILLE... TROIS MOYENS DE SURVIRE !



K'NEX®

Building System
Système De Construction

7+

RELIC™



RELIC™

Relic is a mysterious, lizard-like creature found on ZeKor. He is one of the most intelligent inhabitants of the planet, relying on stealth and strategy over strength. However, his segmented tail is very strong and he uses it to knock his enemies away and launch exploding disks with incredible accuracy.

Relic's PowerCore is Abyss, giving him the ability to collapse the ground under his enemies' feet. Relic is always tough competition for the elite pilots.

Relic est une créature mystérieuse ressemblant à un lézard, et que l'on trouve sur ZeKor. Il est l'un des habitants les plus intelligents de la planète, s'en remettant plus sur la ruse et la stratégie que sur la force. Sa queue, constituée de plusieurs segments, est toutefois très puissante, et il s'en sert pour faire reculer ses ennemis ou lancer des disques qui explosent avec une précision absolument stupéfiante.

Le PowerCore de Relic est le gouffre, l'aptitude à faire s'effondre le sol sous les pieds de ses adversaires. Relic est toujours un adversaire redoutable pour l'équipe de pilotes d'élite.



THE MYSTERIOUS CREATURE RELIC
SITS ATOP A CLIFF, WATCHING AS
RYDER ZOOMS ACROSS THE
ZEKORIAN PLAIN.

LA CRÉATURE MYSTÉRIEUSE RELIC
JUCHÉE SUR LE SOMMET D'UNE COLLINE,
OBSERVANT RYDER TRAVERSANT EN TROMBE
LA PLAINE ZEKORIAN.





"IT'S BEEN ODDLY QUIET
AROUND HERE TONIGHT!"
" C'EST ANORMALEMENT
CALME ICI CE SOIR ! "



RELIC OPENS UP THE GROUND WITH
HIS ABYSS POWERCORE.

RELIC, GRÂCE À SON POWERCORE
DU GOULFRE, FEND LA TERRE.



RYDER, NOTICING THE
NEWLY FORMED HOLE,
USES HIS **SUPER SPEED**
POWERCORE AND LEAPS
OVER THE TRAP.

RYDER, REMARQUANT LE
TROU NOUVELLEMENT
FORMÉ, SE SERT DE SON
POWERCORE SUPER SPEED
ET BONDIT PAR DESSUS LE
TROU, ÉVITANT AINSI LE PIÈGE.



RELIC LEAPS DOWN
AND ATTACKS RYDER.

RELIC SE PRÉCIPITE SUR
RYDER ET L'ATTAQUE.

HE OPENS A NEW
TRENCH WITH HIS
POWERCORE.

IL CRÉE UNE
NOUVELLE TRANCHÉE
À L'AIDE DE
SON POWERCORE.



AFTER RYDER LEAPS OVER THE TRENCH,
RELIC BEGINS LAUNCHING DISKS
FROM HIS TAIL.

UNE FOIS QUE RYDER A BONDÉ PAR-DESSUS
LA TRANCHÉE, RELIC SE MET À LANCER DES
DISQUES À PARTIR DE SA QUELLE.



AFTER RYDER IS HIT, RELIC
OPENS A CHASM, TRAPPING HIM.

UNE FOIS QUE RYDER A BONDÉ
PAR-DESSUS LA TRANCHÉE,
RELIC SE MET À LANCER DES
DISQUES À PARTIR DE SA QUEUE.

RRUMMBLULEEE

RELIC READIES TO
POUNCE ON THE
FALLEN RYDER.

RYDER UNE FOIS
TOUCHÉ, RELIC FAIT
APPARAÎTRE UN
GOLIFFRE, LE
PRENANT AU PIÈGE.

3



1

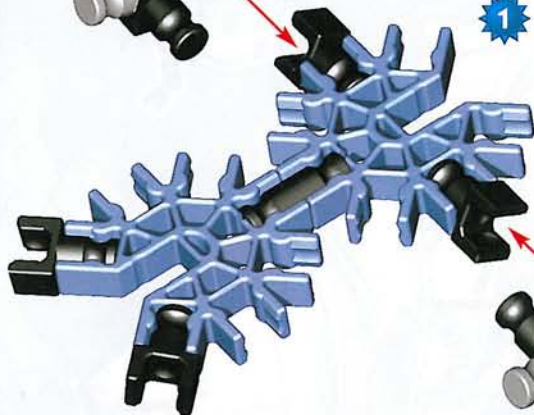

2



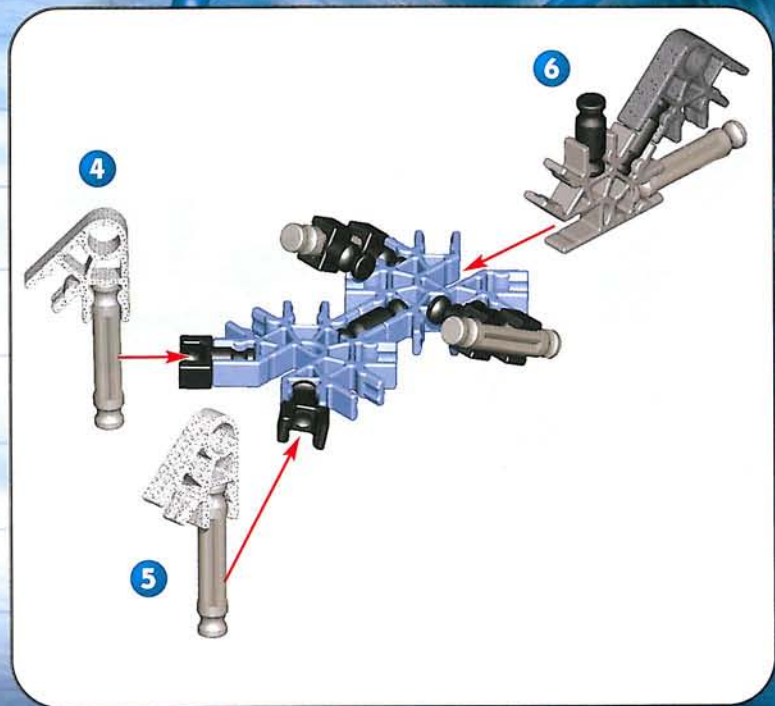

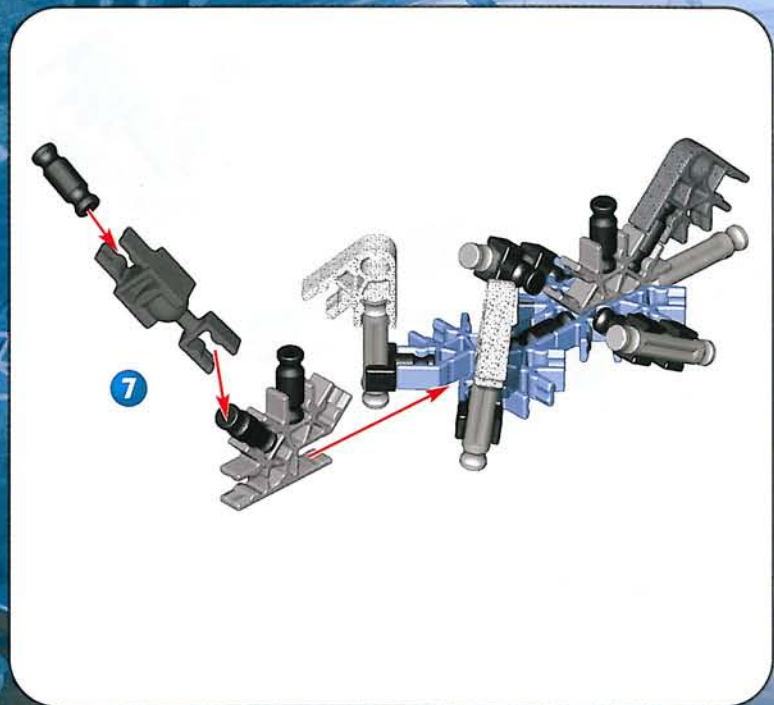

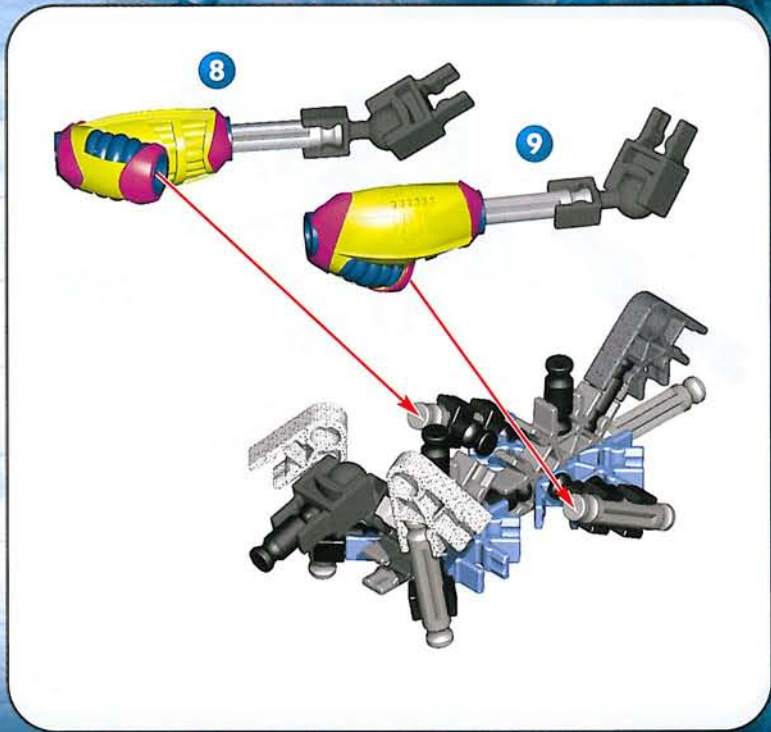

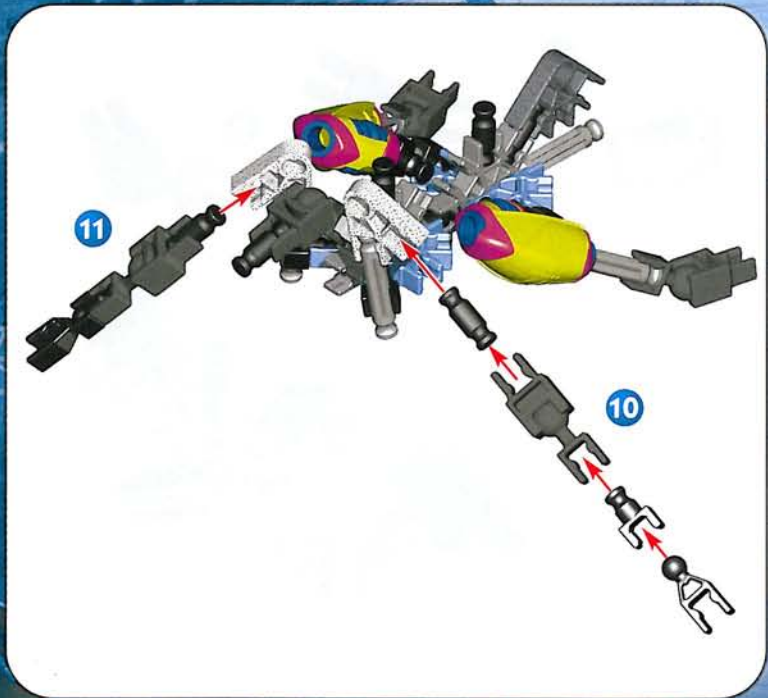

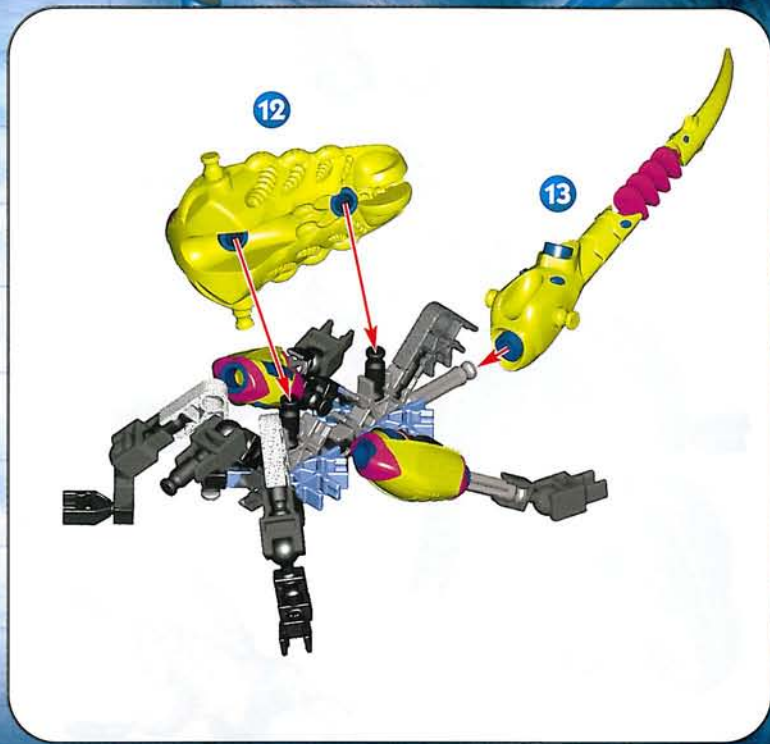

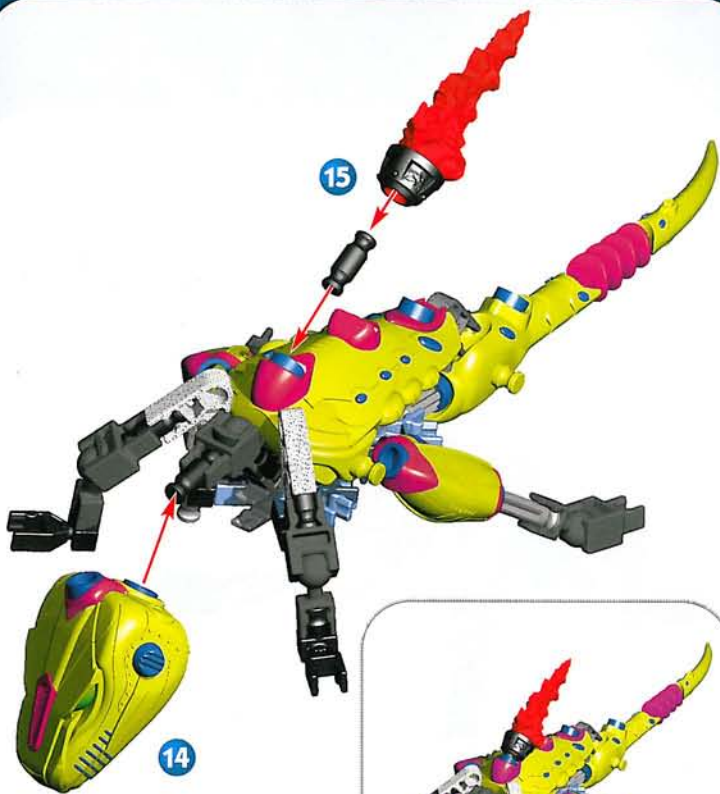

RYDER, TRAPPED IN THE NEWLY FORMED CHASM, NOTICES RELIC CLOSING IN ON HIM.

RELIC S'APPÊTE À SAUTER SUR RYDER QUI GÎT AU FOND DU TROU.



THE ZEKORIAN CREATURE CHANGES SHAPE TO PREPARE FOR BATTLE AGAINST THE RECENTLY CHANGED RYDER.

LA CRÉATURE ZEKORIAN CHANGE DE FORME POUR SE PRÉPARER À LA BATAILLE CONTRE RYDER QUI S'EST RÉCEMMENT MÉTAMORPHOSÉ.



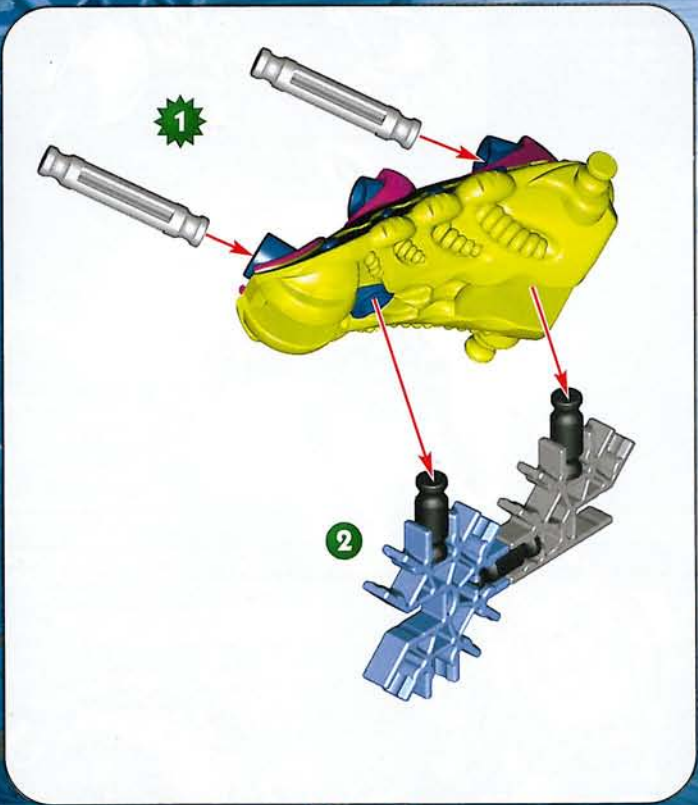

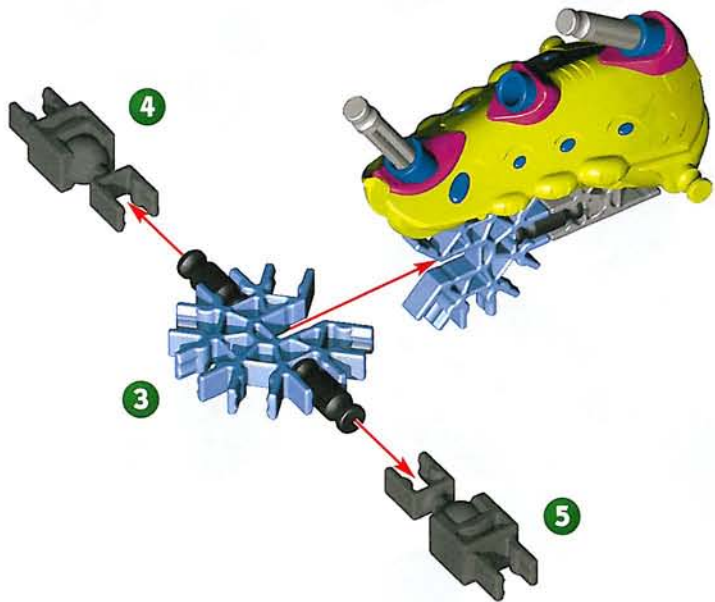

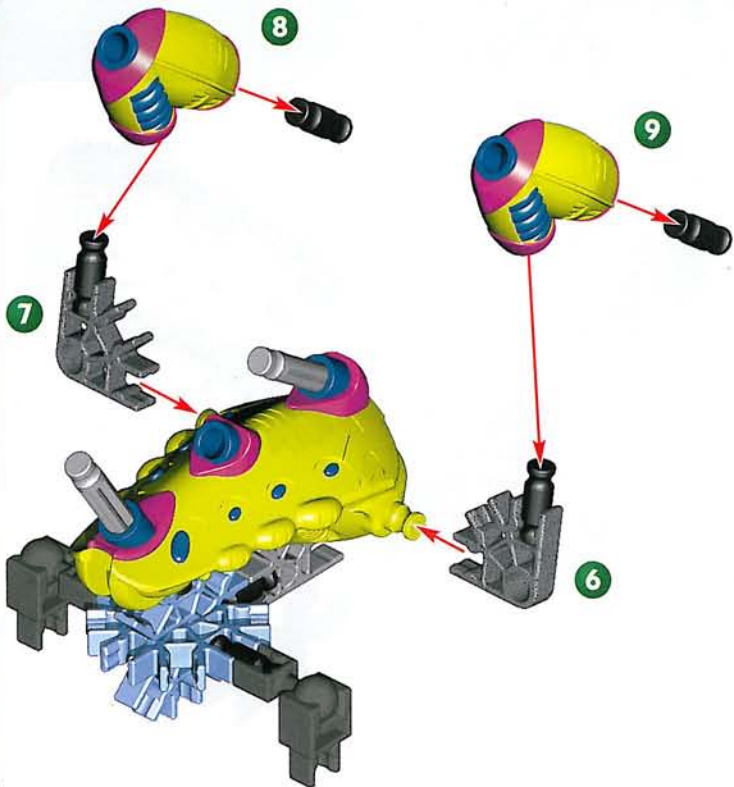

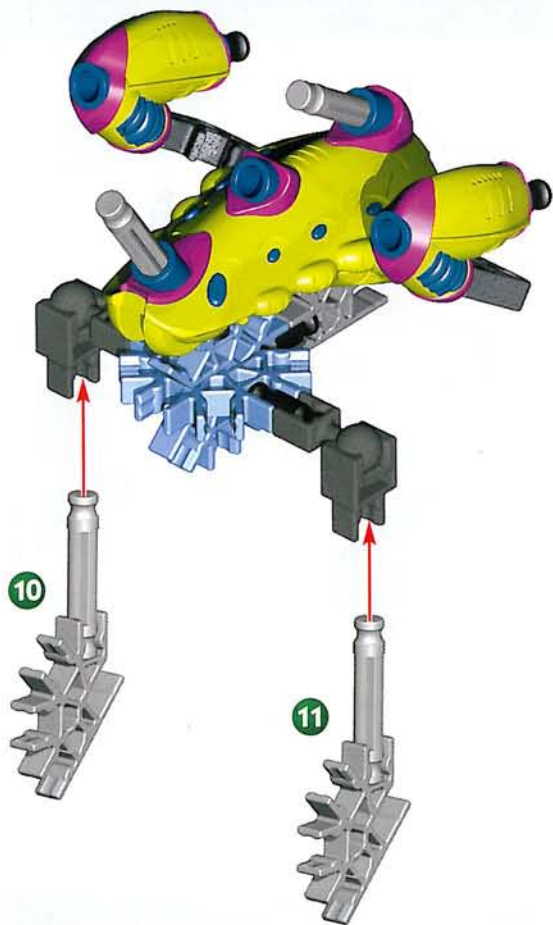

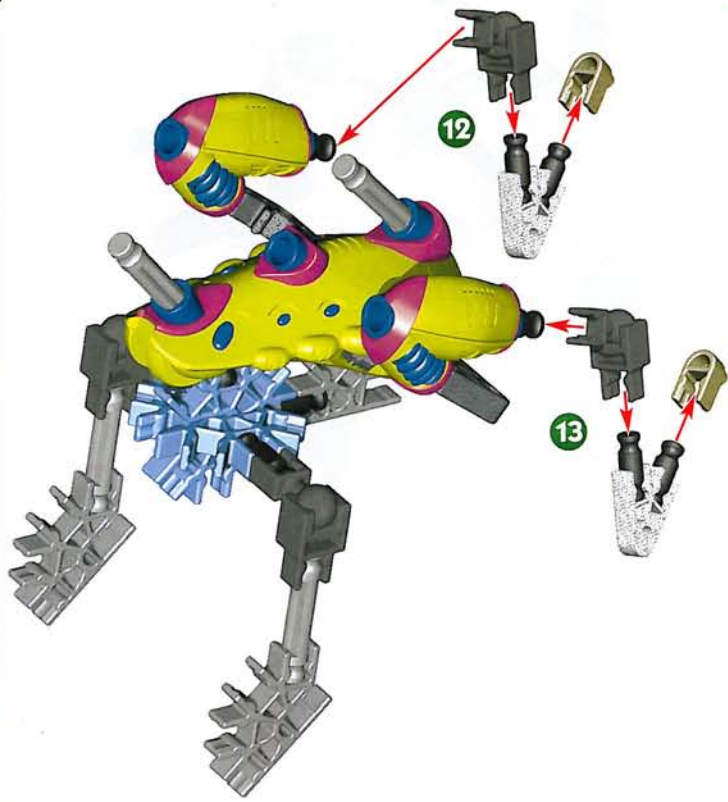

12

13

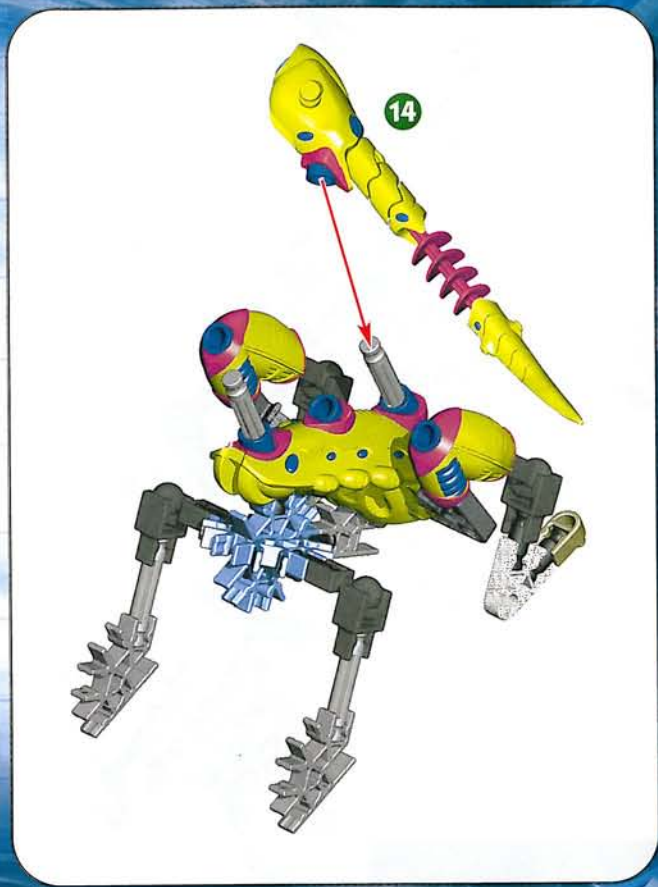

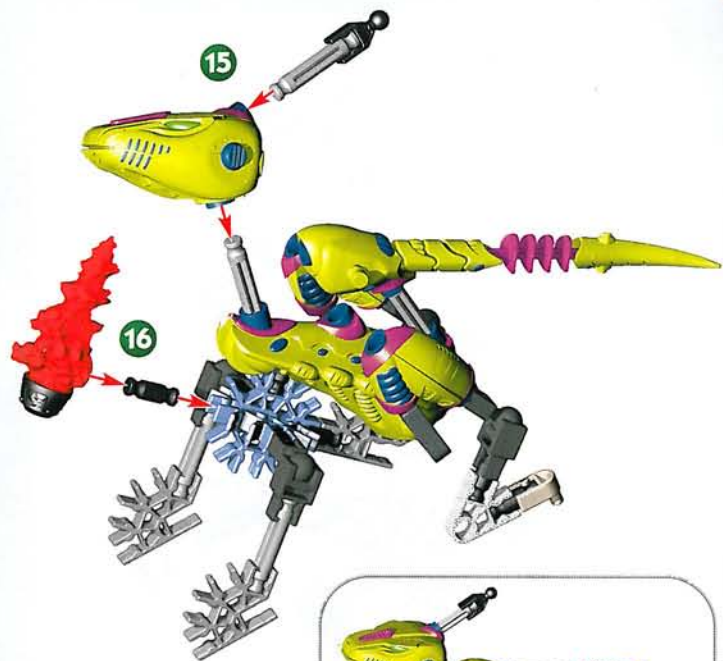



RELIC TAPS INTO HIS **ABYSS** POWERCORE SENDING TONS OF ROCK TUMBLING DOWN ON TOP OF RYDER.

RELIC FAIT APPEL À SON POWERCORE DU GOUFFRE POUR PRÉCIPITER DES TONNES DE ROCHERS SUR RYDER.



RELIC CHANGES SHAPE AGAIN, APPROACHES THE ROCK COVERED RYDER, AND STEALS HIS POWERCORE.

RELIC CHANGE DE NOUVEAU DE FORME, APPROCHE DE RYDER QUI EST ENSEVELI SOUS LES ROCHERS, ET S'EMPARE DE SON POWERCORE.

LEAVING THE FALLEN RYDER BEHIND, AND COLLECTING HIS SUPER SPEED POWERCORE, RELIC BEGINS TO THINK ABOUT THE POSSIBILITIES HE WILL NOW BE CAPABLE OF...

ABANDONNANT DERRIÈRE RYDER, ET RÉCOLTANT SON POWERCORE DE SUPER VITESSE, RELIC COMMENCE À RÉFLÉCHIR À TOUTES LES POSSIBILITÉS QUI S'OFFRENT DÉSORMAIS À LUI...



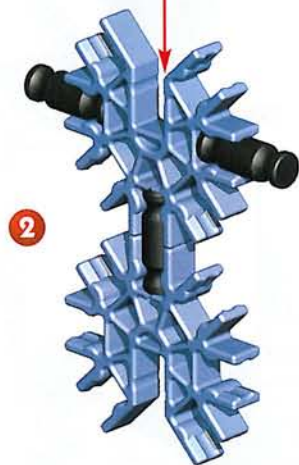

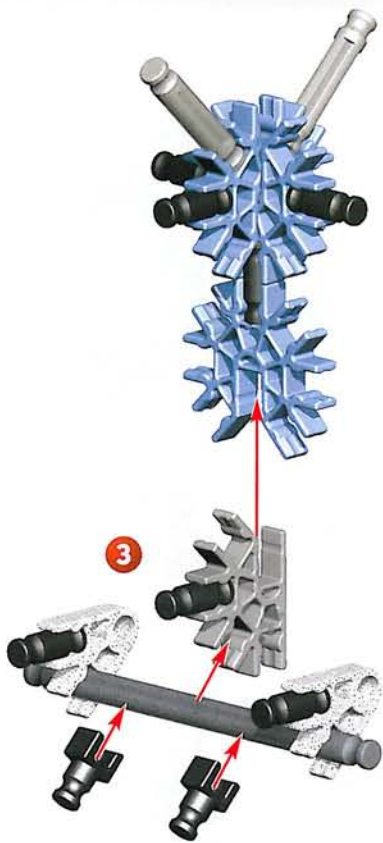

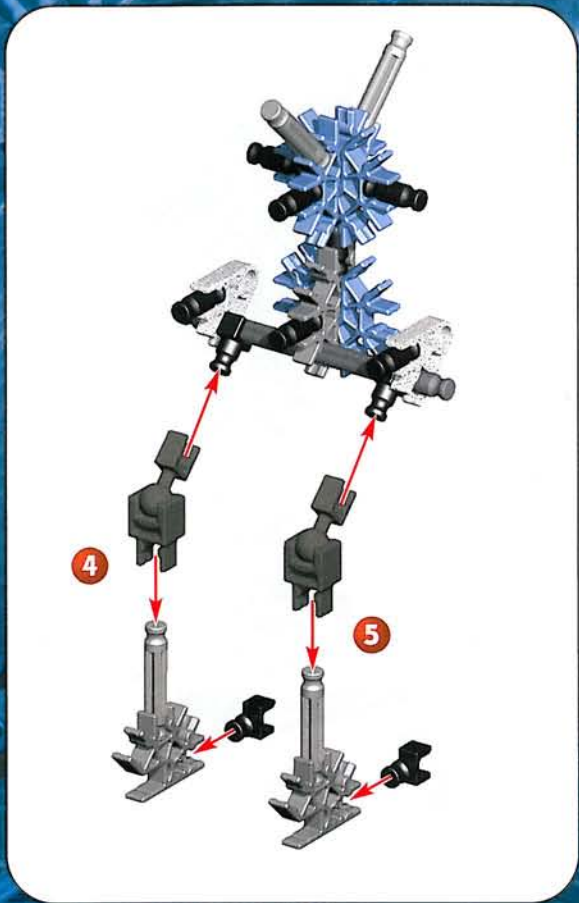

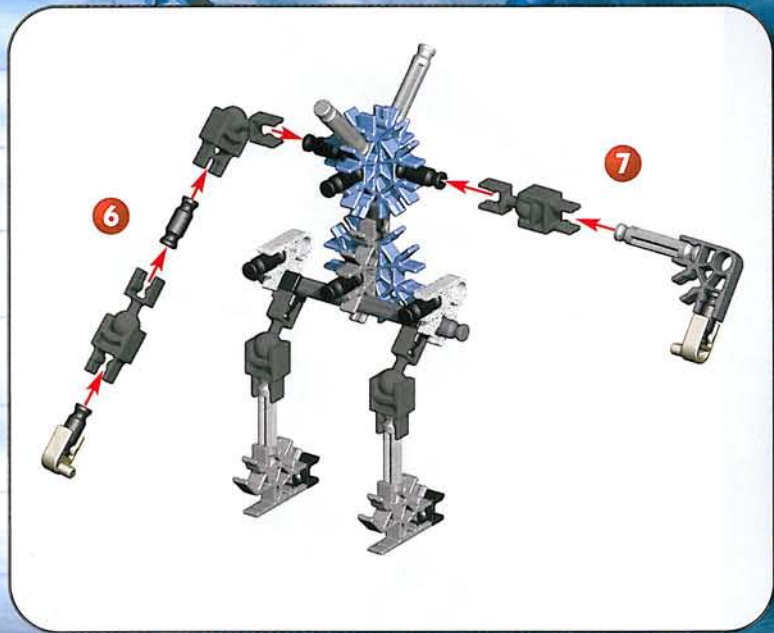

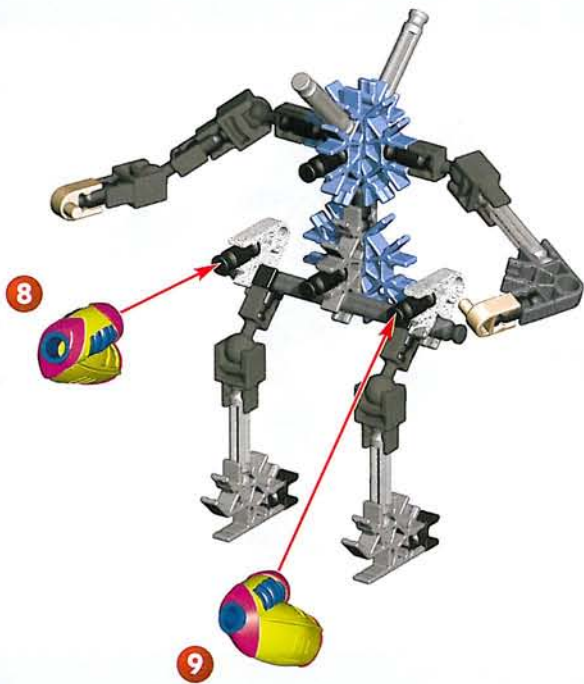

10



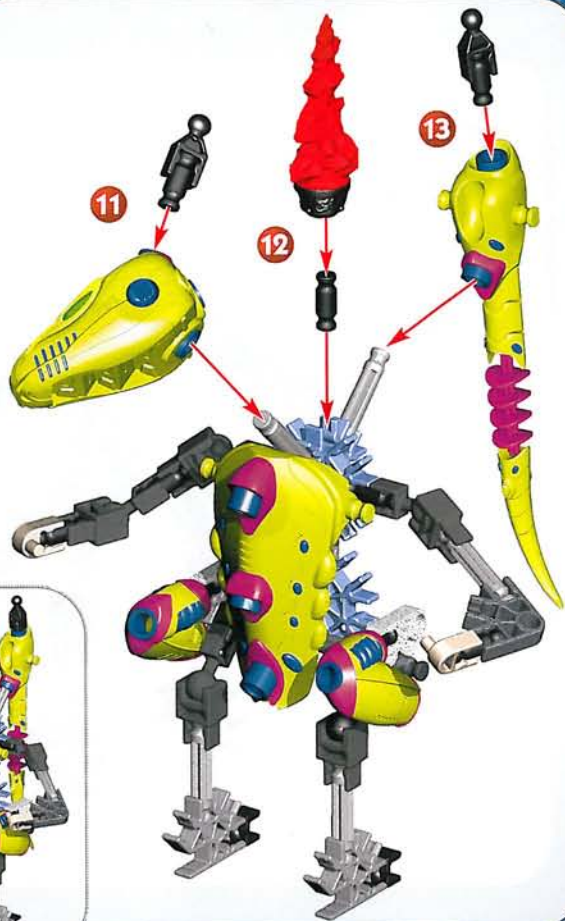

SPECIAL FEATURES *ATTRIBUTS SPÉCIAUX*

**PUSH TAIL DOWN AND
RELEASE TO LAUNCH DISK**
*POUSSE SUR LA QUEUE VERS LE BAS,
ET RELÂCHER POUR LANCER LE DISQUE.*

**ABYSS POWERCORE
POWERCORE DE GOUFFRE**

**PLACE DISK ON TAIL
PLACE LE DISQUE
SUR LA QUEUE**

**WHIPPING TAIL
QUEUE FOUETTANTE**

**Caution: Do not launch in the direction of people, animals, or walls; you could cause injury or damage.
Never attempt to launch any projectiles other than K'NEX discs.**

Mise en garde : ne pas lancer en direction de personnes, d'animaux, ou de murs pour éviter le risque de blesser quelqu'un ou de provoquer des dégâts. Ne jamais tenter de lancer d'autres projectiles que les disques K'NEX.

Opgelet: Niet lanceren in de richting van mensen, dieren of muren; je zou letsel of schade kunnen veroorzaken. Nooit proberen om andere projectielen dan K'NEX schijven te lanceren.

POWERCORE REGENERATING UNIT

UNITÉ DE RÉGÉNÉRATION DU POWERCORE



You've captured the enemy's PowerCore (sold separately), and your own was depleted during the struggle. Now is the time to regenerate them both for use in your next battle. Place both PowerCores in the PCRU, recharge, and be prepared for the next fight!

Tu as capturé le PowerCore de l'ennemi (vendu séparément), et le tien a été affaibli au cours de la bataille. Est maintenant l'heure de les régénérer tous les deux pour l'usage dans votre prochaine bataille. Placez les deux noyaux de puissance dans le PCRU, recharge, et soyez préparé pour le prochain combat!

PARTS COUNT NOMBRE DE PIÈCES



www.REKONSTRUCTORS.com

Enter all 3 ZeKorian creature codes for complete, online Mega-Build instructions.

Entre les codes de tous les 3 créatures ZeKorian pour obtenir en ligne des instructions complètes de Mega-Build.



MEGA BUILD

RELIC: 10838

TEMPEST: ----

RAZOR: ----

Enter THEIR World - Get the Story, Play the Game!
Entre dans LEUR monde - Connais l'histoire, Joue le jeu!



Collect 'em All!
Collectionne-les tous!

RAZOR™

SKYHAWK™

Remote Control
RAVAGE™

RELIC™



TEMPEST™



SHADOW™



DIESEL™



RYDER™





©2003 K'NEX Industries, Inc. P.O. Box 700 Hatfield, PA 19440-0700



US 1-800-KID-KNEX US/Canada only (English only)

GB 00800-22427276 UK/Ireland only

F E D NL 001-215-996-4823



US Consumer Services
K'NEX Industries, Inc.
P.O. Box 700
Hatfield, PA 19440-0700



GB K'NEX
Newport Consumer Services
Hasbro UK Ltd., Caswell Way
Newport, Gwent NP9 0YH



www.knex.com



email@knex.com



WARNING:

CHOKING HAZARD- Small parts.
Not for children under 3 years.



AVERTISSEMENT:

DANGER D'ÉTOUFFEMENT- Pièces de petite
taille Ne pas donner aux enfants de moins de 3 ans.



WAARSCHUWING:

VERSTIKKINGSGEVAAR- In verband met kleine
onderdelen niet geschikt voor kinderen tot 3 jaar.

Printed in China
Imprimerie aux China

Product and colors may vary. Models can be built one at a time. K'NEX is a registered trademark of K'NEX Industries, Inc. Le produit et les couleurs peuvent varier. La plupart des modèles peuvent être construits un à la fois. K'NEX est une marque déposée de K'NEX Industries, Inc.

Manufactured under U.S. Patents/Fabriqué sous brevets américains 5,061,219; 5,137,486; 5,199,919; 6,460,572. Other U.S. and foreign patents pending. Autres brevets américains et étrangers en instance.

Conforms to the Requirements of ASTM Standard Consumer Safety Specification on Toy Safety E963-96a. Conforme aux spécifications de

