

10834/48340

REKONSTRUCTORS™

ONE BATTLE... 3 WAYS TO SURVIVE!

UNE BATAILLE... TROIS MOYENS DE SURVIVRE !



K'NEX®

Building System
Système De Construction

7+

RAZOR™



RAZOR™

Razor is a scorpion-like creature that resides in the caves and caverns of the planet ZeKor. He is one of the most feared and ferocious of the planet's inhabitants. He is often the aggressor in battle. When Razor attacks his enemies, he relies on his tremendously sharp pinchers and strong armor.

Razor's large claws render his foes incapable of defense and his deadly stinger tail can launch exploding disks.

Razor's PowerCore is Hologram, the ability to cast multiple images of himself. This power scares and confuses his adversaries. Razor is the most formidable of the elite pilots' enemies.

Razor est une créature qui ressemble à un scorpion et qui vit dans les grottes et les cavernes de la planète ZeKor. Il est l'un des habitants les plus redoutés et les plus féroces de la planète, et au cours d'une bataille, il est souvent l'agresseur. Lorsqu'il attaque ses ennemis, Razor s'en remet surtout à ses pinces acérées et son armure presque indestructible. Les grosses pinces de Razor neutralisent ses adversaires et son dard mortel peut lancer des disques qui explosent.

Le PowerCore de Razor, l'hologramme, multiplie son image, ce qui effraie ses ennemis et jette de la confusion parmi eux. Razor est l'ennemi le plus redoutable de tous les pilotes d'élite.

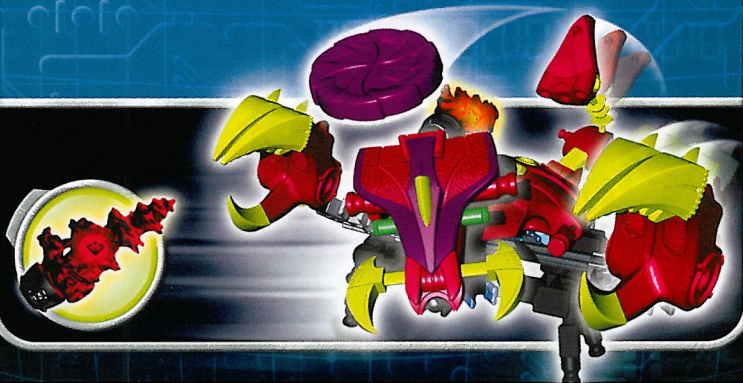

SKYHAWK, SCOUTING THE ZEKORIAN
LANDSCAPE, SPOTS RAZOR GUARDING
A MYSTERIOUS CAVE ENTRANCE.

SKYHAWK, QUI EFFECTUE UNE
RECONNAISSANCE DU TERRAIN
ZEKORIAN, REPÈRE RAZOR QUI
MONTE LA GARDE À L'ENTRÉE D'UNE
GROTTE MYSTÉRIEUSE.

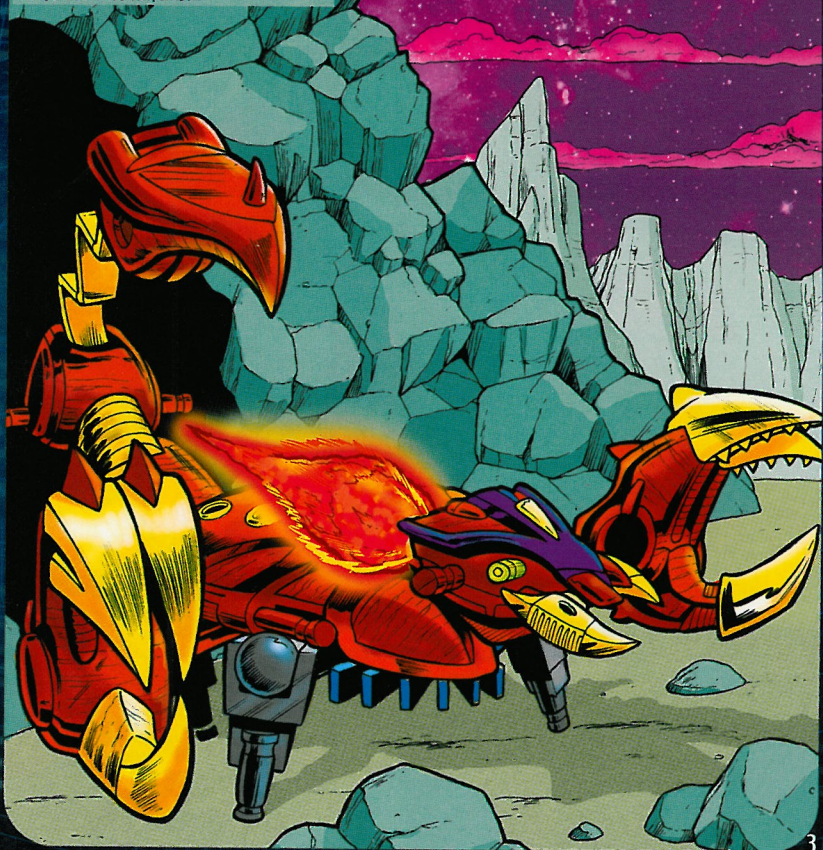



AS SKYHAWK IS FLYING BY, RAZOR SPOTS HIM. SKYHAWK QUI EST DANS LES AIRS À PROXIMITÉ, EST REPÉRÉ PAR RAZOR.



INSTANTLY, RAZOR, USING HIS HOLOGRAM POWERCORE, MAKES DUPLICATES OF HIMSELF APPEAR.

EN UN CLIN D'ŒIL, RAZOR, UTILISANT SON POWERCORE HOLOGRAMME, FAIT APPARAÎTRE DES DOUBLES DE LUI-MÊME.



"WHAT THE...?
WHERE DID THEY ALL COME FROM?"
NOM D'UNE PIPE...?
D'OÙ SORTENT-ILS ?

RAZOR LAUNCHES A DISK FROM HIS TAIL, BUT WITH ALL THE HOLOGRAMS, IT APPEARS TO SKYHAWK AS A SKY FULL OF DISKS.

RAZOR LANCE UN DISQUE DE SA QUEUE, MAIS À CAUSE DE TOUS LES HOLOGRAMMES, SKYHAWK A L'IMPRESSION QUE LE CIEL EST CONSTELLÉ DE DISQUES.



SKYHAWK USES HIS **FORCE FIELD** POWERCORE TO SURROUND HIMSELF, AND THEN SHOWS OFF SOME FLYING EXPERTISE, AVOIDING ALL THE EXPLOSIONS. SKYHAWK UTILISE SON POWERCORE CHAMP DE FORCE POUR SE PROTÉGER, PUIS DÉMONTRE SON HABILITÉ EN VOL, EN ÉVITANT TOUTES LES EXPLOSIONS.

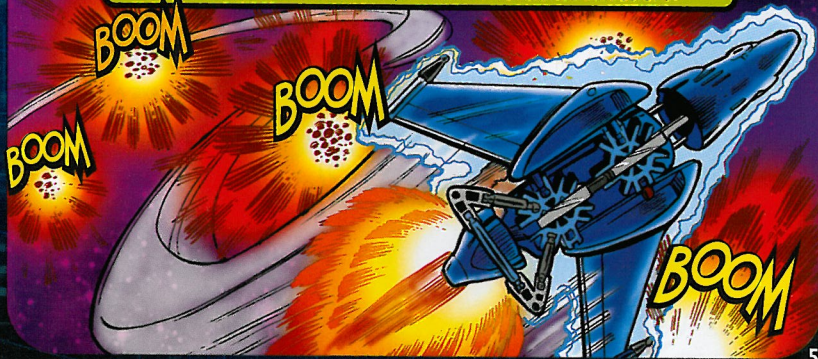



SKYHAWK BATTLES BACK,
FIRING MISSILES TOWARD RAZOR.

SKYHAWK RÉPOND, EN TIRANT
DES MISSILES EN DIRECTION
DE RAZOR.

ONE OF SKYHAWK'S
MISSILES, APPARENTLY
A DIRECT HIT, PASSES
RIGHT THROUGH
ONE OF THE
HOLOGRAPHIC
RAZORS.

L'UN DES MISSILES DE
SKYHAWK, UNE
FRAPPE DIRECTE
APPAREMMENT,
TRAVERSE TOUT
BONNEMENT
L'UN DES RAZORS
HOLOGRAPHIQUES.



"IT WENT RIGHT
THROUGH HIM...!?"
CELA L'A TRAVERSÉ !?



"I HAVE A PLAN TO
FIND THE REAL RAZOR."
J'AI UNE IDÉE POUR
TROUVER LE VÉRITABLE
RAZOR.

SKYHAWK LANDS AND IS IMMEDIATELY
SURROUNDED BY RAZOR AND
HIS HOLOGRAPHIC COMPANIONS.

SKYHAWK ATTERRIT ET EST
IMMÉDIATEMENT ENCELRÉ PAR
RAZOR ET SES COMPAGNONS
HOLOGRAPHIQUES.

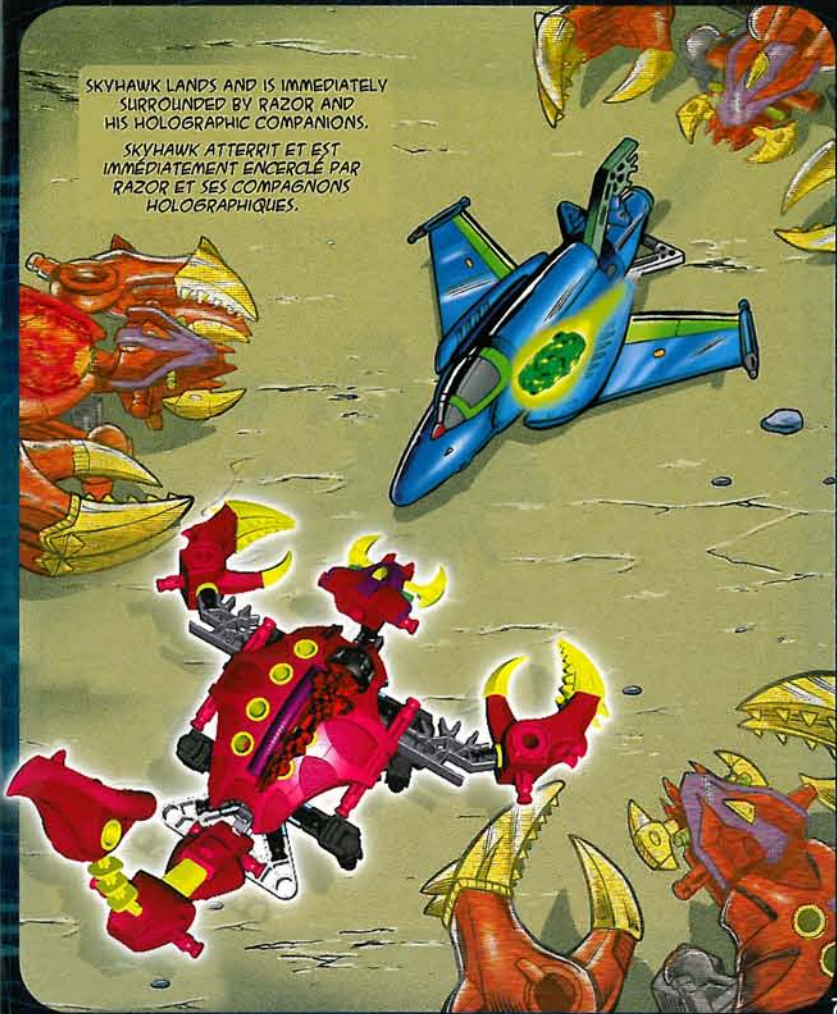

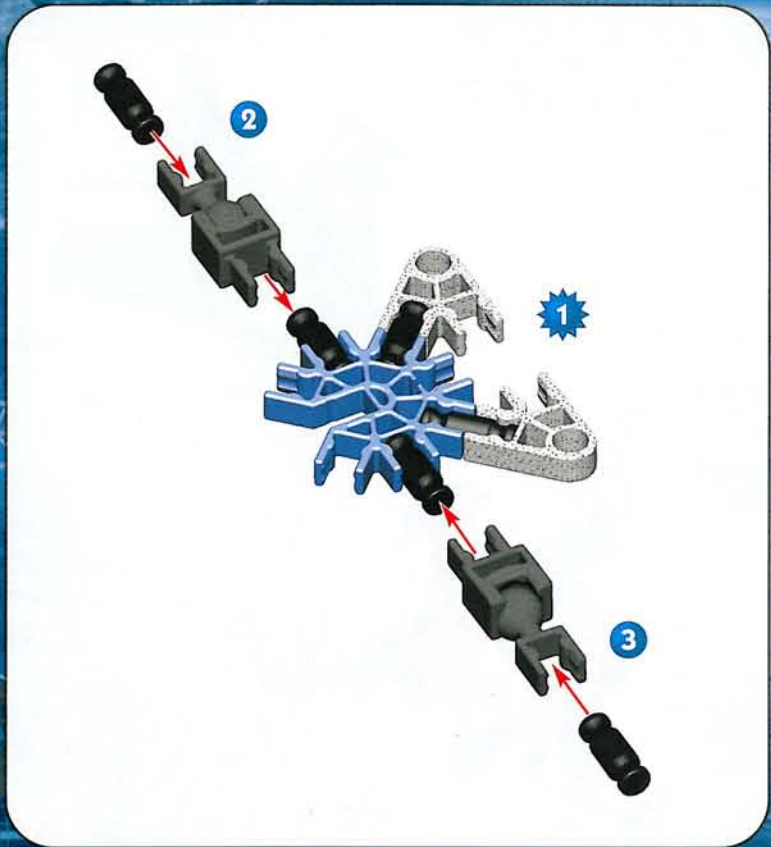

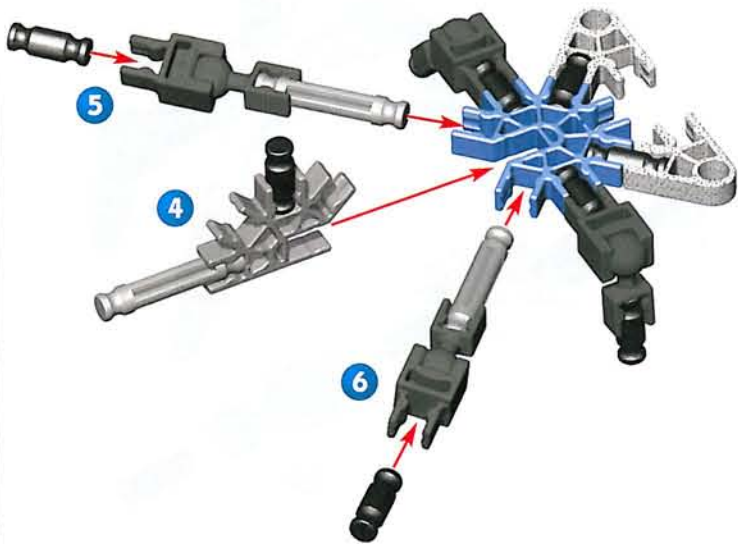

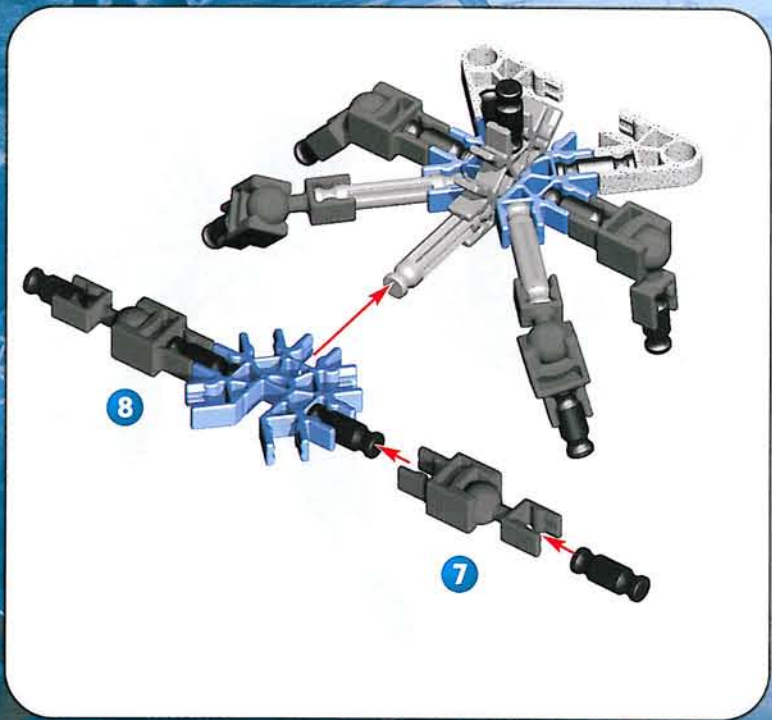

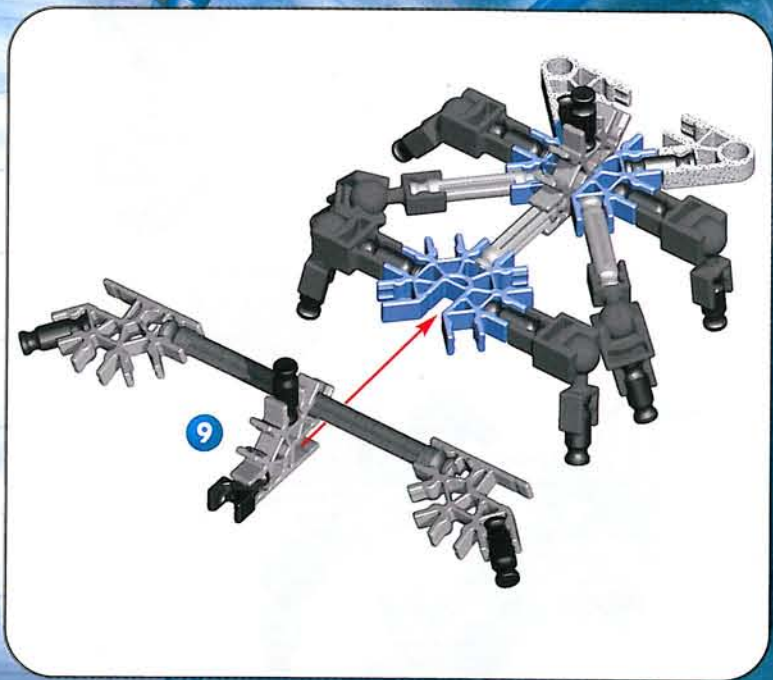



US **GB** Purple stripes in front

F Les raies pourpres vont sur le devant

NL Purperstrepen vooraan





12



14



13

SKYHAWK INITIATES HIS POWERCORE FORCE FIELD AND BLASTS ALL THE SURROUNDING RAZORS.

SKYHAWK LANCE SON CHAMP DE FORCE POWERCORE ET TIRE SUR TOUS LES RAZORS QUI LE CERNENT.

AS THEY ARE BLASTED BACK, THE HOLOGRAMS BEGIN TO DISAPPEAR, LEAVING THE ONE REAL RAZOR.

ÉTANT ATTEINTS PAR LE FEU, LES HOLOGRAMMES COMMENCENT À DISPARAÎTRE, NE LAISSANT QUE LE VÉRITABLE RAZOR.

SENSING THE ONCOMING ATTACK OF SKYHAWK, RAZOR "REKONSTRUCTS" INTO A DIFFERENT SHAPE.

PRESSANT L'ATTAQUE IMMINENTE DE SKYHAWK, RAZOR REKONSTRUCTS EN UNE FORME DIFFÉRENTE.



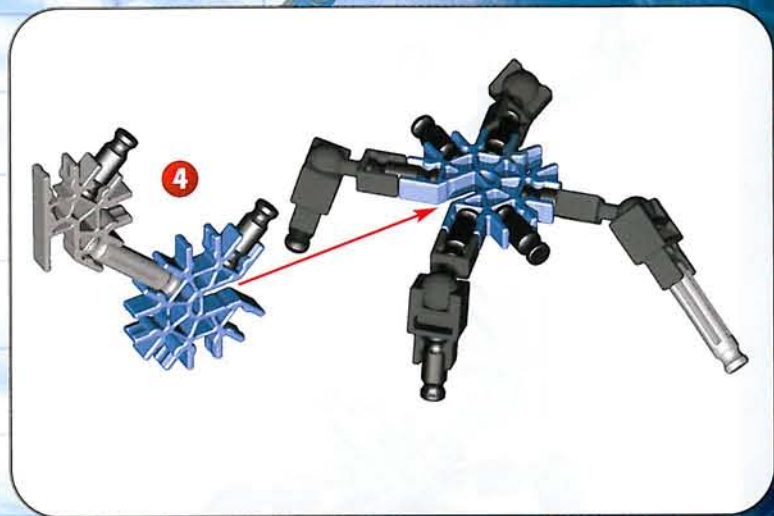

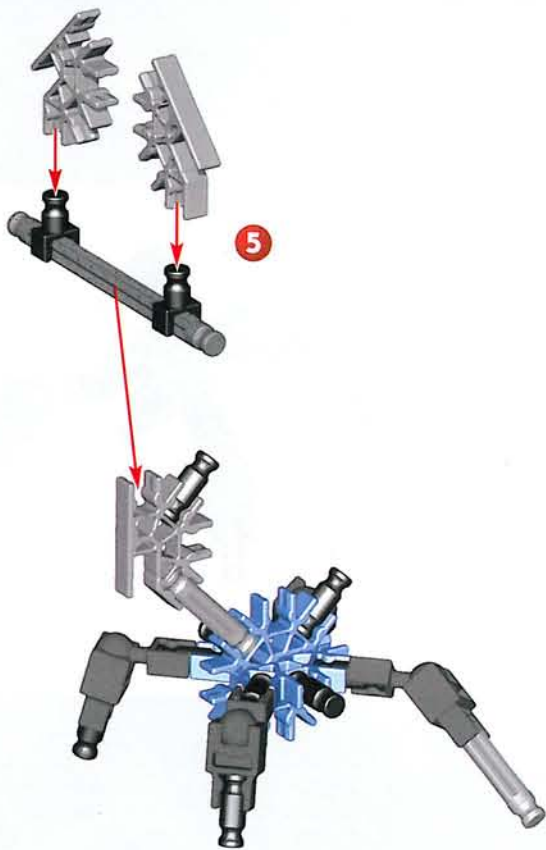

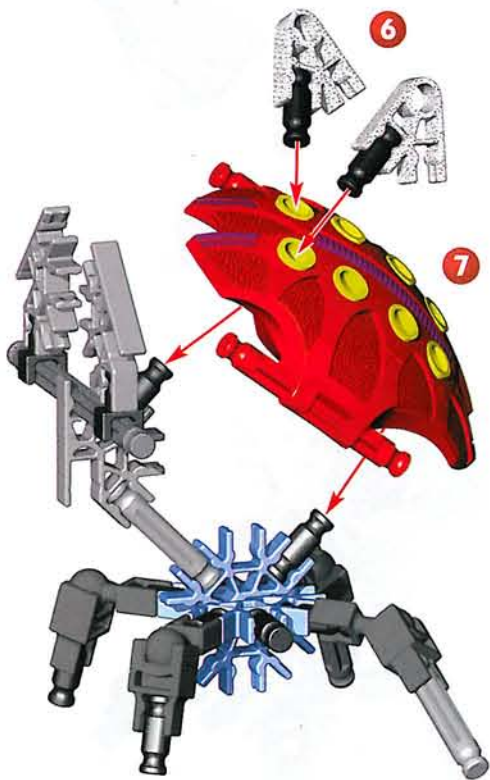



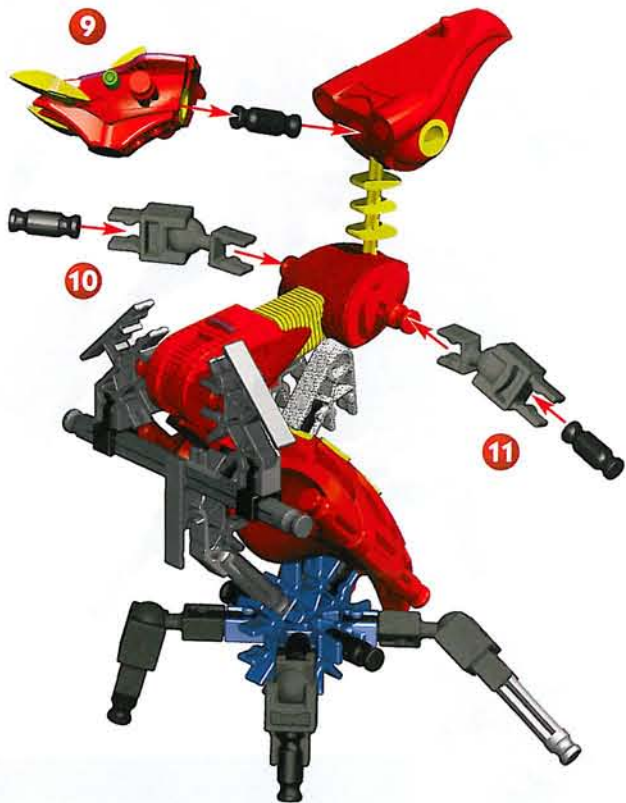



AFTER CHANGING SHAPE, RAZOR
LEAPS OVER SKYHAWK'S BLAST.
APRÈS AVOIR CHANGÉ DE FORME,
RAZOR BONDIT AU-DESSUS DE LA
TRAIÑÉE DE SKYHAWK.

VEZ ZAAAAAT

LAUNCHING HIS OWN
ATTACK, RAZOR DEFEATS
SKYHAWK WITH A DISK.

LANÇANT SA PROPRE
ATTAQUE, RAZOR BAT
SKYHAWK AVEC UN DISQUE.

WHIRZZZ

RAZOR THEN COLLECTS SKYHAWK'S
POWERCORE, LEAVING HIM WEAK
AND POWERLESS.

RAZOR RÉCOLTE LE POWERCORE DE
SKYHAWK, LE LAISSANT AFFAIBLI ET
SANS DÉFENSE.

RAZOR CHANGES SHAPE AGAIN AND USES
HIS POWERFUL CLAWS TO DIG AN ESCAPE ROUTE.
RAZOR CHANGE DE NOUVEAU DE MODE ET SE
SERT DE SES GRIFFES PUISSANTES POUR CREUSER
UN CHEMIN D'ÉVASION.

KKPRRAASSSS

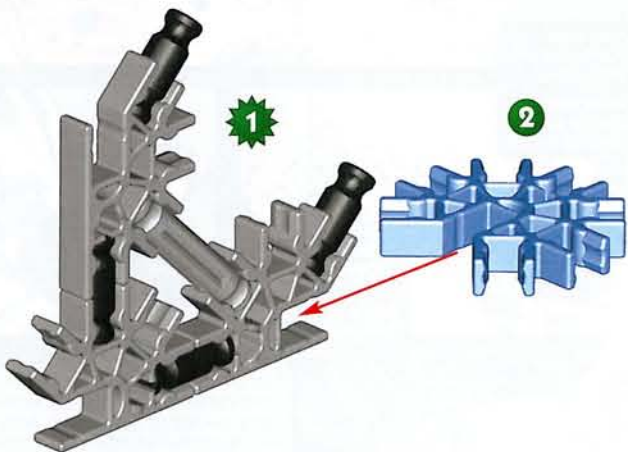

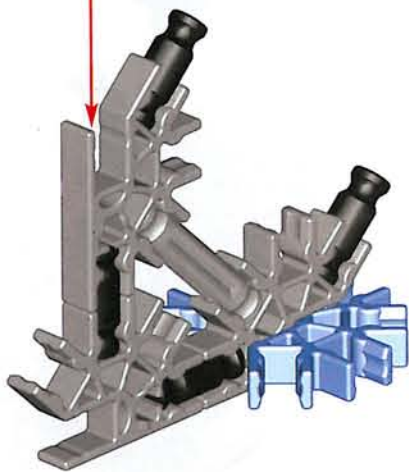
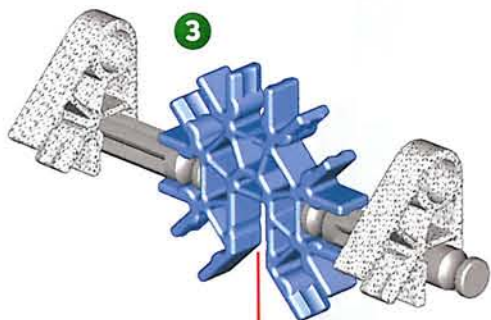



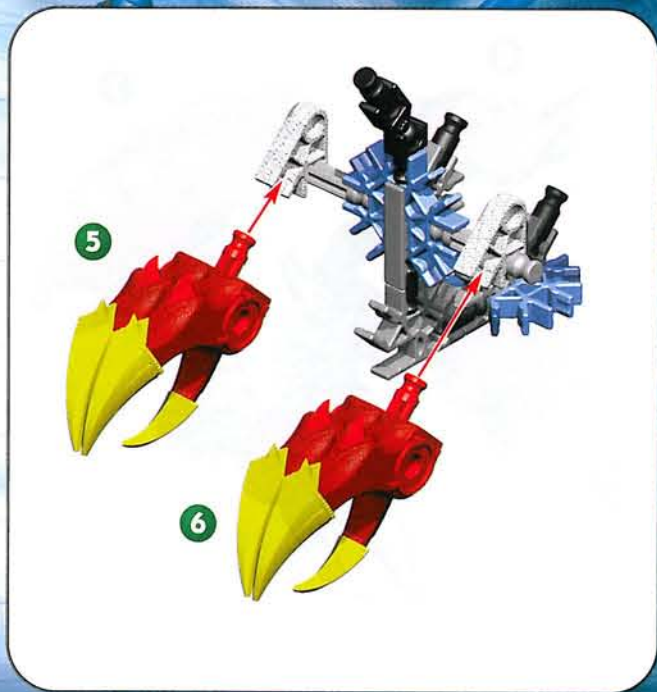

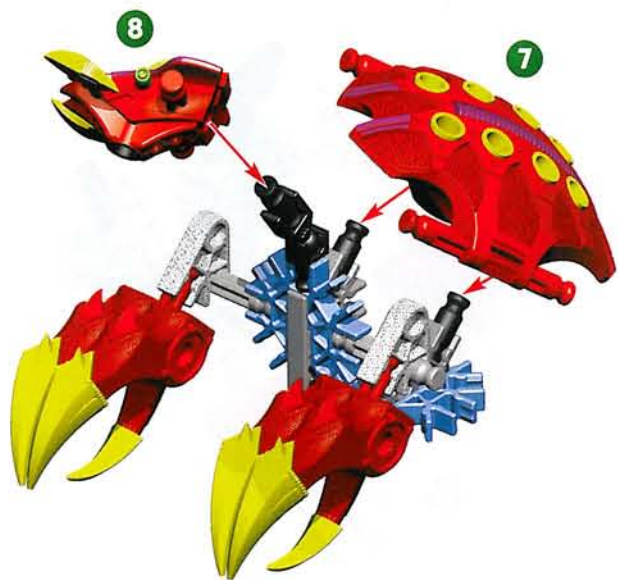



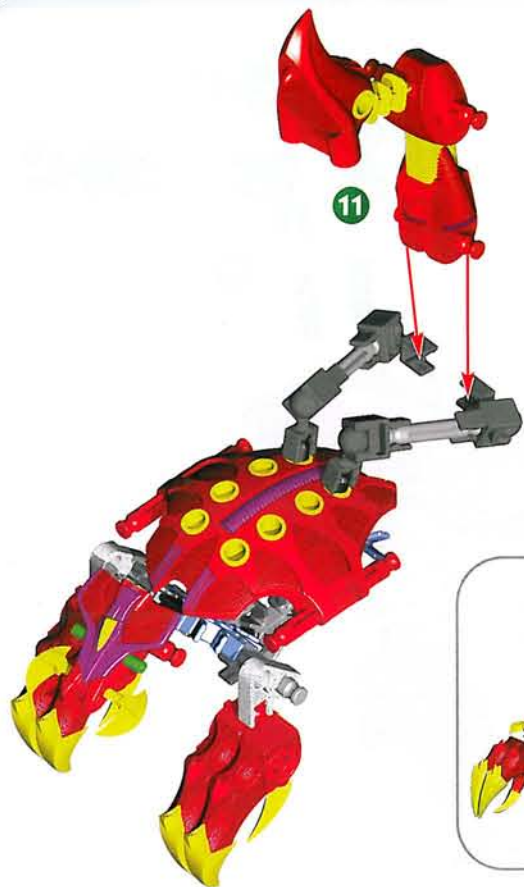

SPECIAL FEATURES *ATTRIBUTS SPÉCIAUX*

**HOLOGRAM
POWERCORE
POWERCORE
D'HOLOGRAMME**

**PUSH TAIL DOWN AND
RELEASE TO LAUNCH DISK
POUSSE SUR LA QUEUE VERS
LE BAS, ET RELÂCHER POUR
LANCER LE DISQUE**

**PLACE DISK ON TAIL
PLACE LE DISQUE
SUR LA QUEUE**

**PRESS BUTTON TO
ACTIVATE PINCHING
MANDIBLES
APPUÏE SUR LE
BOUTON POUR
ACTIVER LES
MANDIBULES
QUI PINCENT**

**Caution: Do not launch in the direction of people, animals, or walls; you could cause injury or damage.
Never attempt to launch any projectiles other than K'NEX discs.**

Mise en garde : ne pas lancer en direction de personnes, d'animaux, ou de murs pour éviter le risque de blesser quelqu'un ou de provoquer des dégâts. Ne jamais tenter de lancer d'autres projectiles que les disques K'NEX.

Opgelet: Niet lanceren in de richting van mensen, dieren of muren; je zou letsel of schade kunnen veroorzaken. Nooit proberen om andere projectielen dan K'NEX schijven te lanceren.



POWERCORE REGENERATING UNIT *UNITÉ DE RÉGÉNÉRATION DU POWERCORE*



You've captured the enemy's PowerCore (sold separately), and your own was depleted during the struggle. Now is the time to regenerate them both for use in your next battle. Place both PowerCores in the PCRU, recharge, and be prepared for the next fight!

Tu as capturé le PowerCore de l'ennemi (vendu séparément), et le tien a été affaibli au cours de la bataille. Est maintenant l'heure de les régénérer tous les deux pour l'usage dans votre prochaine bataille. Placez les deux noyaux de puissance dans le PCRU, recharge, et soyez préparé pour le prochain combat!

PARTS COUNT *NOMBRE DE PIÈCES*



www.REKONSTRUCTORS.com

Enter all 3 ZeKorian creature codes for complete, online Mega-Build instructions.

Entre les codes de tous les 3 créatures ZeKorian pour obtenir en ligne des instructions complètes de Mega-Build.



MEGA BUILD

RELIC: ----

TEMPEST: ----

RAZOR: 10834

Enter THEIR World - Get the Story, Play the Game!
Entre dans LEUR monde - Connais l'histoire, Joue le jeu !



Collect 'em All!
Collectionne-les tous!

RAZOR™



SKYHAWK™



Remote Control
RAVAGE™



RELIC™

TEMPEST™



SHADOW™



DIESEL™



RYDER™



©2003 K'NEX Industries, Inc. P.O. Box 700 Hatfield, PA 19440-0700



US 1-800-KID-KNEX US/Canada only (English only)

GB 00800-22427276 UK/Ireland only

F E D NL 001-215-996-4823



US **Consumer Services**
K'NEX Industries, Inc.
P.O. Box 700
Hatfield, PA 19440-0700



GB **K'NEX**
Newport Consumer Services
Hasbro UK Ltd., Caswell Way
Newport, Gwent NP9 0YH



www.knex.com



email@knex.com



WARNING:

CHOKING HAZARD- Small parts.
Not for children under 3 years.



AVERTISSEMENT:

DANGER D'ÉTOUFFEMENT- Pièces de petite
taille Ne pas donner aux enfants de moins de 3 ans.



WAARSCHUWING:

VERSTIKKINGSGEVAAR- In verband met kleine
onderdelen niet geschikt voor kinderen tot 3 jaar.

Printed in China
Imprimerie aux China

Product and colors may vary. Models can be built one at a time. K'NEX is a registered trademark of K'NEX Industries, Inc. Le produit et les couleurs peuvent varier. La plupart des modèles peuvent être construits un à la fois. K'NEX est une marque déposée de K'NEX Industries, Inc.

Manufactured under U.S. Patents/Fabriqué sous brevets américains 5,061,219; 5,137,486; 5,199,919; 6,460,572. Other U.S. and foreign patents pending. Autres brevets américains et étrangers en instance.

Conforms to the Requirements of ASTM Standard Consumer Safety Specification on Toy Safety, F963-96a. Conforme aux spécifications de sécurité du consommateur sur la sécurité des jouets de la norme ASTM F963-96a.



402022 11 11 11 03