

14146/48347

# REKONSTRUCTORS™

ONE BATTLE... 3 WAYS TO SURVIVE!  
UNE BATAILLE... TROIS MOYENS DE SURVIVRE !



**K'NEX**

Building System  
Système De Construction

9+

**RAVAGE™**



# RAVAGE™

Until the invasion of the Elite Pilots from earth, ZeKor was a peaceful planet. However, peace came at a price. Ravage, the leader of the ZeKorians, ruled by brute force, crushing his opponents with all his powers to maintain control. The new enemy, the strange Elite Pilots, have enabled Ravage and his fellow ZeKorians to forge an unbreakable bond. The ZeKorians follow Ravage into battle, shifting shapes to survive.

Ravage's PowerCore is Telekinetic Strength, enabling him to move his foes with his thoughts, paralyzing them. Ravage takes careful aim with his lethal missiles, destroying the invaders. Ravage's fearsome size and power make him the undisputed ZeKorian leader.

Jusqu'à l'invasion des Pilotes d'Élite, qui arrivaient de la terre, la planète ZeKor était une planète pacifique. Mais cette paix était chère payée. Ravage, le leader des ZeKorians, imposait la loi, brutale, du plus fort, écrasant ses adversaires afin de maintenir un contrôle sur l'autre. Le nouvel ennemi, les curieux Pilotes d'Élite ont permis à Ravage et à ses acolytes, les ZeKorians, de forger des liens indestructibles. Les ZeKorians suivent Ravage sur le champ de bataille et changent de forme pour survivre !

Le PowerCore de Ravage est la force télécinétique, qui lui permet de déplacer ses adversaires avec ses pensées, les paralysant. Ravage vise soigneusement avec ses missiles meurtriers, détruisant les envahisseurs. La taille et la puissance terrifiantes de Ravage en font le leader absolu des ZeKorians.





TEAM LEADER RAVAGE IS ON PATROL WITH TEMPEST, RELIC AND RAZOR. THEIR MISSION: TO SEEK OUT AND CAPTURE THE POWERCORE FROM THEIR DEADLIEST ENEMY - DIESEL!

LE LEADER DE L'ÉQUIPE, RAVAGE, EST EN PATROUILLE AVEC TEMPEST, RELIC ET RAZOR. LEUR MISSION : PARTIR À LA RECHERCHE ET S'EMPARER DU POWERCORE DE LEUR ENNEMI LE PLUS REDOUTABLE - DIESEL !



READY FOR BATTLE, THE TWO TEAMS CONFRONT EACH OTHER!  
PRÊTES À LA BATAILLE, LES DEUX ÉQUIPES SE DÉFIENT !

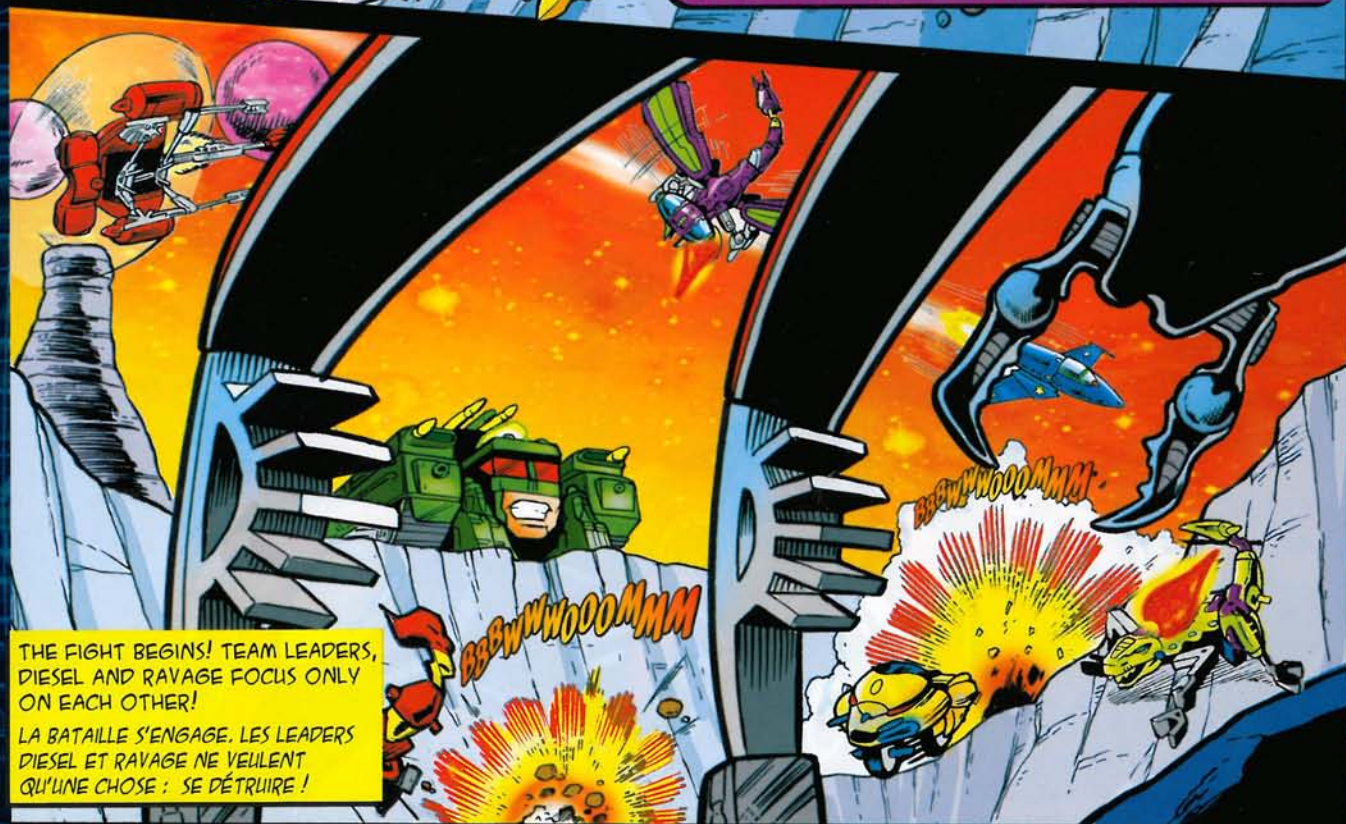

THE FIGHT BEGINS! TEAM LEADERS,  
DIESEL AND RAVAGE FOCUS ONLY  
ON EACH OTHER!

LA BATAILLE S'ENGAGE. LES LEADERS  
DIESEL ET RAVAGE NE VEULENT  
QU'UNE CHOSE : SE DÉTRUIRE !

DIESEL UNLEASHES HIS SONIC BOOM POWERCORE.  
DIESEL DÉCHAÎNE SON POWERCORE DE BANG SUPERSONIQUE.



**KAABOOM**



DIESEL'S SONIC BOOM DESTROYS THE GROUND BENEATH RAVAGE.  
LE BANG SUPERSONIQUE DE DIESEL DÉTRUIT LE TERRAIN OÙ SE TIENT RAVAGE.



DIESEL CAUTIOUSLY APPROACHES THE FALLEN RAVAGE.  
DIESEL APPROCHE AVEC MÉFIANCE RAVAGE, QUI EST À TERRE.

"LOOKS LIKE YOU'RE FINISHED, RAVAGE!"  
ON DIRAIT BIEN QUE TU ES FINI, RAVAGE!



RAVAGE, PRETENDING TO BE INJURED, GRABS DIESEL WITH HIS TELEKINESIS POWERCORE!  
RAVAGE, FAISANT SEMBLANT D'ÊTRE BLESSÉ, EMPLOIGNE DIESEL GRÂCE À SON POWERCORE DE TÉLÉKINÉSIE.

RAVAGE, USING HIS TELEKINETIC POWER, LIFTS DIESEL HIGH INTO THE AIR.  
RAVAGE, SE SERVANT DE SES POUVOIRS DE TÉLÉKINÉSIE, SOULÈVE DIESEL HAUT DANS LES AIRS.





CAUGHT  
IN RAVAGE'S  
TELEKINETIC HOLD,  
DIESEL UNLEASHES  
HIS HOVERCRAFT MISSILE LAUNCHER.  
EMPRISONNÉ DANS LA PRISE TÉLÉKINÉTIQUE  
DE RAVAGE, DIESEL LÂCHE LE LANCEUR  
DE MISSILES DE SON VAISSEAU.

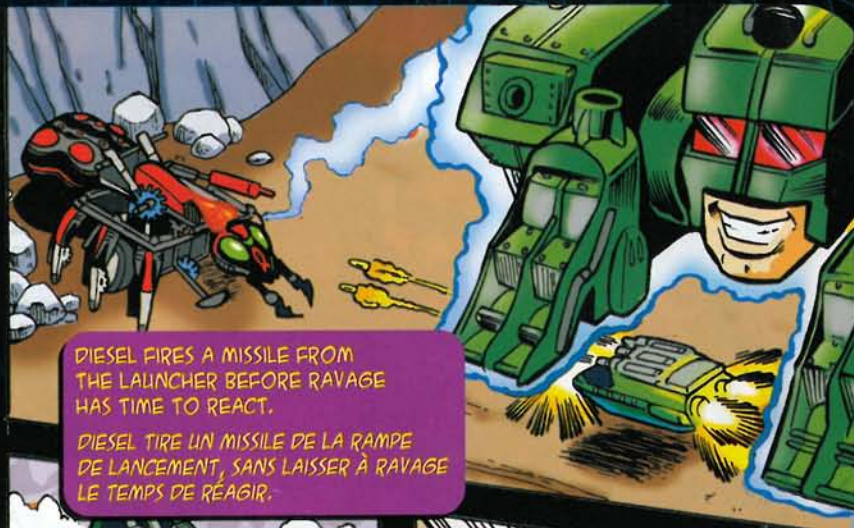

DIESEL FIRES A MISSILE FROM  
THE LAUNCHER BEFORE RAVAGE  
HAS TIME TO REACT.

DIESEL TIRE UN MISSILE DE LA  
RAMPÉ DE LANCEMENT, SANS LAISSER À RAVAGE  
LE TEMPS DE RÉAGIR.

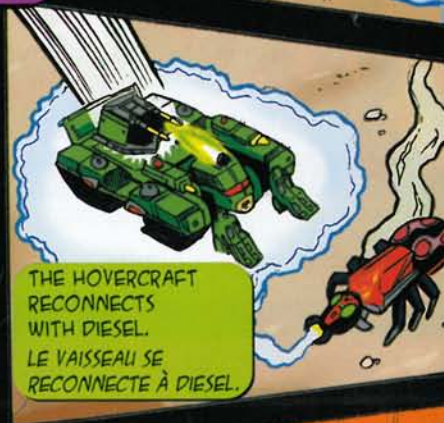

THE HOVERCRAFT  
RECONNECTS  
WITH DIESEL.  
LE VAISSEAU SE  
RECONNECTE À DIESEL.



RAVAGE'S INJURY BREAKS  
HIS TELEKINETIC HOLD ON  
DIESEL, MAKING DIESEL FALL

LES BLESSURES DE RAVAGE ANNIHILENT  
LA PRISE TÉLÉKINÉTIQUE QU'IL A SUR  
DIESEL, CE QUI ENTRAÎNE LA  
CHUTE DE DIESEL.



WHOA!  
I HOPE THAT DIDN'T  
FEEL AS BAD AS IT LOOKED!  
OUI LA LA ! J'ESPÈRE QUE ÇA N'A  
PAS FAIT AUSSI MAL QUE L'ON  
POURRAIT LE CROIRE  
À LE VOIR !



RAVAGE RECOVERS AND FIRES  
A MISSILE AT THE FALLEN DIESEL.  
RAVAGE RÉCUPÈRE ET LANCE UN MISSILE  
EN DIRECTION DE DIESEL QUI EST À TERRE.



DIESEL IS HURT, BUT STILL STRONG ENOUGH TO  
USE HIS BATTERING RAM TO SLAM INTO RAVAGE!  
DIESEL EST BLESSÉ, MAIS SUFFISAMMENT FORT  
ENCORE POUR SE PRÉCIPITER SUR RAVAGE ET LUI  
RENTRE DEDANS EN SE SERVANT DE SON BÉLIER !

- US GB** Read all instructions and warnings before you start to build and operate the models. Keep these instructions in a handy location. They contain important safety information.
- F** Lis tous les avertissements et les instructions avant de commencer le montage et l'exploitation du modèle. Garde ces instructions à portée de la main. Elles comportent d'importantes informations de sécurité.
- NL** Gelieve alle waarschuwingen en aanwijzingen te lezen vóór je het model begint op te bouwen en te gebruiken. Bewaar deze aanwijzingen op een gemakkelijk bereikbare plaats. Ze bevatten belangrijke veiligheidsgegevens.

**US GB IMPORTANT INFORMATION:** Changes or modifications to this unit not expressly approved by the party responsible for compliance could void the user's authority to operate the equipment.

**F INFORMATIONS IMPORTANTES :** Les changements ou les modifications à cette unité qui ne sont pas expressément agréés par la personne chargée du respect de la conformité sont susceptibles d'annuler l'autorité de l'utilisateur de faire marcher le matériel.

**NL BELANGRIJKE INFORMATIE:** Veranderingen aan dit geheel die niet uitdrukkelijk goedgekeurd zijn door de partij die verantwoordelijk is voor het nakomen van de regels, kan eventueel het gebruik van de uitrusting door de gebruiker ongeldig maken.

**US GB WARNING:** This is a Class 1 LED product.

**US** FCC Statements:

This device complies with Part 15 of the FCC rules. Operation is subject to the following two conditions:

1. This device may not cause harmful interference and
2. This device must accept any interference received including interference that may cause undesired operation.

This model is tested to comply with FCC standards - FOR HOME AND OFFICE USE.

FCC Statement:

This equipment has been tested and found to comply with the limits for a Class B digital device, pursuant to part 15 of the FCC rules. These limits were designed to provide reasonable protection against harmful interference in a residential installation. This equipment generates, uses, and can radiate radio frequency energy, and, if not installed and used in accordance with the instructions, may cause harmful interference to radio communications. However, there is no guarantee that interference will not occur in a particular installation. If this equipment does cause harmful interference to radio or television reception, which can be determined by turning the equipment off and on, the user is encouraged to try to correct the interference by one or more of the following measures:

- (1) Reorient or relocate the receiving antenna.
- (2) Increase the separation between the equipment and receiver.
- (3) Consult the dealer or an experienced radio/TV technician.

**F AVERTISSEMENT :** ce produit est un produit de Classe 1 LED.

**NL WAARSCHUWING:** dit is een klasse 1 LED-product.

**US GB** The Ant Head comes with 3 button cell batteries already installed. Remove PowerCore and/or Eyes when toy is not in use.

**F** La tête de la fourmi contient trois piles boutons (ou LR44, A76, ou SR44) déjà installées. Retire le PowerCore et/ou les Yeux lorsque tu n'utilises pas le jouet.

**NL** De Ant Head wordt geleverd met 3 reeds geïnstalleerde knopcel- (of LR44, A76 of SR44) batterijen. Verwijder PowerCore en/of Ogen wanneer het speelgoed niet in gebruik is.

**US GB WARNING:** As with all small items, these batteries should be kept away from children. If swallowed, seek medical attention immediately.

**F AVERTISSEMENT :** comme avec tous les petits objets, ces piles doivent être tenues hors de la portée des enfants. En cas d'ingestion, appeler immédiatement un médecin ou l'hôpital.

**NL WAARSCHUWING:** Zoals het geval is met alle kleine onderwerpen, moeten deze kleine batterijen verwijderd blijven van kinderen. Ingeval van inslikken, kijk onmiddellijk uit naar medische verzorging.

**US GB** To replace batteries, remove the screw as shown. Insert 3 button cell (or LR44, A76 or SR44) batteries, matching the (+/-) diagram inside the compartment.

**F** Pour remettre les piles, retirer la vis comme l'indique le schéma. Installer 3 piles boutons LR44 (A76 ou SR44), en suivant le diagramme (+/-) gravé à l'intérieur du boîtier.

**NL** Verwijder de schroef zoals afgebeeld om de batterijen te vervangen. Steek er 3 LR44 (A76 of SR44) batterijen in, en doe ze overeenstemmen met het (+/-) diagram binnenin het compartiment.

**US GB** Light is activated by inserting a Rod in the hole in the top of the head and inserting the eye piece into the hole between the eyes. Remove PowerCore and/or Eyes when toy is not in use.

**F** L'indicatif lumineux est activé en introduisant une tige dans l'orifice situé dans la partie supérieure de la tête, et en introduisant la pièce servant à constituer les yeux dans l'orifice qui se trouve entre les yeux. Retire le PowerCore et/ou les Yeux lorsque tu n'utilises pas le jouet.

**NL** Het licht wordt aangestoken door een staaf in het gaatje bovenaan het hoofd te steken en door het oogstuk in de opening tussen de ogen te steken. Verwijder PowerCore en/of Ogen wanneer het speelgoed niet in gebruik is.

**US GB** Light doesn't work? Check to see if you have fresh button cell batteries and that they are installed properly.

**F** Le son et/ou la lumière ne marche pas ? Vérifie si les piles sont chargées et si elles sont bien installées.

**NL** Werkt het geluid en/of licht niet? Ga even na of de batterijen geladen zijn en of ze goed op hun plaats zitten.

**US GB Caution:** Do not aim missiles at eyes or face. Never aim missiles at others or pets. Never attempt to launch any projectiles other than the K'NEX foam missiles.

**F** **MISE EN GARDE :** ne vise pas les yeux ou le visage avec les missiles. Ne vise jamais des personnes ou des animaux domestiques avec les missiles. Ne tente jamais de lancer des projectiles autres que les missiles K'NEX en mousse.

**NL** **OPGEPAST:** Geen missielen naar de ogen of het gezicht mikken. Nooit de missielen nooit naar anderen toe of naar geen dieren. Tracht nooit projectielen af te vuren die geen schuimrubberen projectielen van K'NEX zijn.



- US GB** **Caution:** Keep hands, face, hair, clothing and power cord away from all moving parts. Do not trip on cord.
- F** **Attention:** Éloigne les mains, la figure, les cheveux, les vêtements et les cordons électriques de toutes les pièces mobiles. Ne te prends pas les pieds dans le fil.
- NL** **OPGEPAST:** Hou het haar, de vingers, het gezicht en kledij verwijderd van alle bewegende onderdelen. Niet over de koord struikelen.
- US GB** This toy uses an infrared beam similar to that of a TV remote control. Working distance may be affected by weather and lighting conditions.
- F** Ce joué utilise un rayon infrarouge similaire à celui d'une télécommande de téléviseur. La distance de fonctionnement est susceptible d'être affectée par le temps ou la luminosité.
- NL** Dit product gebruikt infra rood licht zoals bij de afstandsbediening van de Televisie. De afstand tot het product wordt beïnvloed door het weer en de hoeveelheid licht.
- US GB** **Battery Safety Instructions:**  
Remove rechargeable batteries from model before charging. Charge batteries under adult supervision only. Do not attempt to recharge non-rechargeable batteries. Do not mix different types of batteries such as alkaline, standard (carbon-zinc), or rechargeable (nickel-cadmium) batteries. Do not mix new and used batteries. Only batteries of the same or equivalent type recommended should be used together. Insert batteries with correct polarity (+/-). Remove exhausted batteries from model. The supply terminals are not to be short-circuited. Alkaline batteries are recommended.  
Do not put small black Rods in any openings of the Gearbox or motor; they will damage the motor and cannot be removed.
- F** Instructions en matière de sécurité des piles : Retirez les piles rechargeables de votre modèle avant de les recharger. Piles non rechargeables. Ne mélangez pas différents types de piles, des piles alcalines par exemple avec des piles standard ou rechargeables. Ne mélangez pas des vieilles piles avec des piles neuves. Seules des piles du même type peuvent être utilisées ensemble. Introduisez les piles en faisant attention à la polarité (+/-). Retirez les piles mortes de votre modèle. Il ne faut pas court-circuiter les bornes d'alimentation.  
N'introduisez pas de petites tiges noires dans les orifices de la boîte de vitesses ou du moteur ; elles abîmeront en effet le moteur et ne pourront pas être retirées.
- NL** Veiligheidsinstructies inzake de batterijen: Verwijder heroplaadbare batterijen uit je model vóór het opladen. Laad de batterijen uitsluitend op onder toezicht van een volwassene. Tracht niet niet-heroplaadbare batterijen terug op te laden. Meng niet verschillende soorten batterijen zoals alkalische, gewone en heroplaadbare batterijen. Meng niet oude en nieuwe batterijen. Uitsluitend batterijen van hetzelfde type dienen gebruikt te worden met mekaar. Steek de batterijen erin volgens de correcte polariteit (+/-). Verwijder ontladen batterijen uit je model. Geen kortsluiting van de toevoeraansluitpunten mag uitgevoerd worden.  
Steek geen kleine zwarte staafjes in de openingen van de versnellingsbak of de motor; ze zullen de motor beschadigen en ze kunnen niet verwijderd worden.

- US GB** **General Operation and Storage:**  
Always store your model in a cool, dry place. If the model gets wet and stops running, let it dry overnight before trying to run it again. If the problem persists, call 1-800-KID-KNEX (USA and Canada only). Always operate your model on dry level surface, away from motor vehicles. Keep the motors free of dust. Do not immerse in water.
- F** Marche et rangement :  
Range toujours ton modèle dans un endroit frais et sec. Si le modèle se mouille et ne marche plus, fais-le sécher toute une nuit avant d'essayer de le faire marcher de nouveau. Si le problème continue, appelle le 1-800-KID-KNEX (USA et Canada seulement). Fais toujours marcher ton modèle sur une surface plane, sèche, à l'écart de véhicules à moteur. Veille à ce qu'il n'y ait pas de poussière dans les moteurs. Ne plonge pas le modèle dans l'eau.
- NL** Algemeen gebruik en opberging: Je model steeds opbergen op een koele en droge plaats. Indien het model nat wordt en niet meer werkt, het gedurende de nacht laten drogen en de volgende morgen trachten het terug te doen werken. Indien het probleem zich blijft voortdoet, bel 1-800-KID-KNEX (uitsluitend voor de VS en Canada). Je model steeds op een droog en plat oppervlak gebruiken, op veilige afstand van motorvoertuigen. De motoren tegen het stof schermen. Het model niet in water dompelen.

- US GB** Set contains one (1) Controller and one (1) Gearbox/Receiver. (Batteries not included.)
- F** La boîte contient un (1) contrôleur et un(e) (1) boîte de vitesses/récepteur. (Piles non comprises).
- NL** De set bevat een (1) bedieningsstuk en een (1) versnellingsbak/ontvanger (exclusief de batterijen).

- US GB** **Battery Requirements:**  
Remote Controller uses: 3 AAA (or LR03) batteries.  
Gearbox/Receiver uses: 4 AA (or LR6) batteries.  
Ant Head comes with 3 button cell (or LR44, A76 or SR44) batteries Already installed.

- F** Piles nécessaires :  
La télécommande utilise : 3 piles AAA (ou LR03).  
La boîte de vitesses/le récepteur utilise : 4 piles AA (ou LR6).  
La tête de la fourmi contient trois piles boutons (ou LR44, A76, ou SR44) déjà installées.

- NL** **Batterijvereisten:**  
Het afstandsbedieningsstuk gebruikt: 3 AAA (of LR03) batterijen.  
De versnellingsbak/ontvanger gebruikt: 4 AA (of LR6) batterijen.  
De Ant Head wordt geleverd met 3 reeds geïnstalleerde knopcel- (of LR44, A76 of SR44) batterijen.

- US GB** **Our Warranty (US and Canada)**  
K'NEX Industries warrants the Ravage Set to be free of manufacturing defects in material and workmanship for a period of 90 days from the date of purchase. If, within the period of warranty, any part proves to have such defect, it will be replaced or repaired at our option at no charge. K'NEX will not be responsible for damage and/or abuse to your Ravage Set, and such will not be covered by this warranty. Also, K'NEX will not be responsible for damage caused by defective or old batteries. Old or damaged batteries can leak and corrode metals. K'NEX's sole and exclusive liability for defects in materials and workmanship shall be limited to repair or replacement by our Consumer Services Department, and K'NEX shall not be liable of incidental, consequential, contingent damages, except in those states that do not allow this exclusion or limitation. This warranty gives you specific legal rights. You may have other rights which vary from state to state.

- F** **Notre garantie (Canada)**  
K'NEX Industries garantit que le jeu d'assemblage Ravage est exempt de vices de fabrication matériels et d'exécution pour une période de 90 jours à partir de la date d'achat. Si, durant la période de garantie, une pièce est défectueuse, nous aurons l'option de la remplacer ou de la réparer gratuitement. K'NEX ne sera pas responsable pour l'endommagement et/ou l'abus de ton jeu Ravage ce qui ne sera pas couvert par la présente garantie. En outre, K'NEX ne sera pas responsable pour les dégâts causés par des piles défectueuses ou épuisées. Les piles défectueuses ou épuisées peuvent fuir et corroder les métaux. La seule responsabilité exclusive de K'NEX pour des défauts matériels et d'exécution sera limitée à la réparation ou le remplacement par notre Service Après-Vente et K'NEX ne sera pas responsable pour des dommages fortuits, indirects, aléatoires, sauf dans les états où une telle exclusion ou restriction est interdite. La présente garantie te donne des droits légaux spécifiques. Tu peux avoir d'autres droits qui peuvent varier d'un état à l'autre.

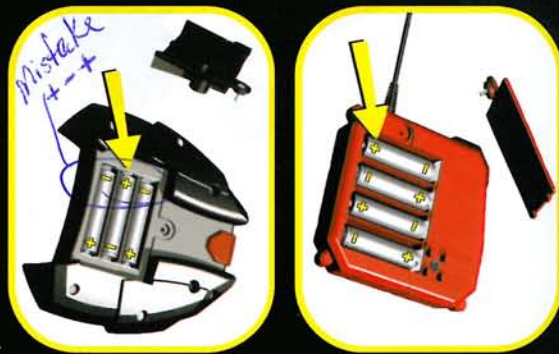

- (US) (GB) Arrow on motor must point down.
- (F) La flèche sur le moteur doit être dirigée vers le bas.
- (NL) De motorpijl moet naar onder gericht zijn.



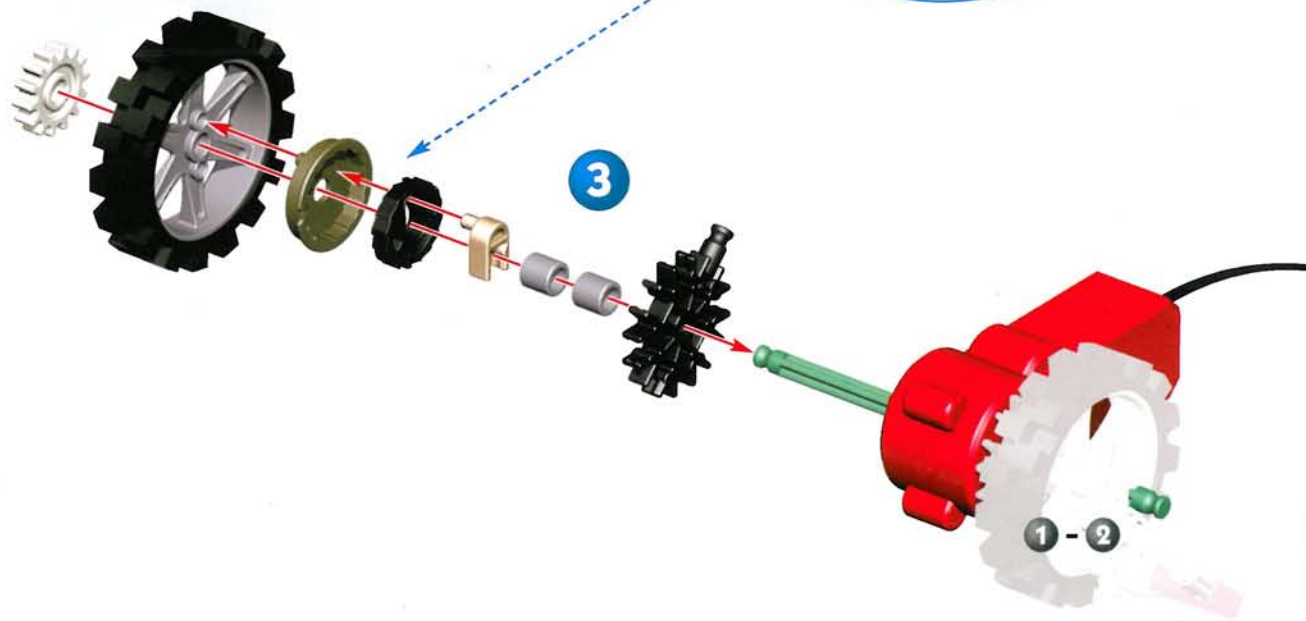
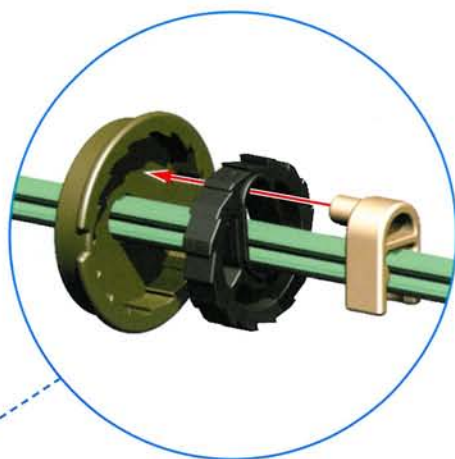

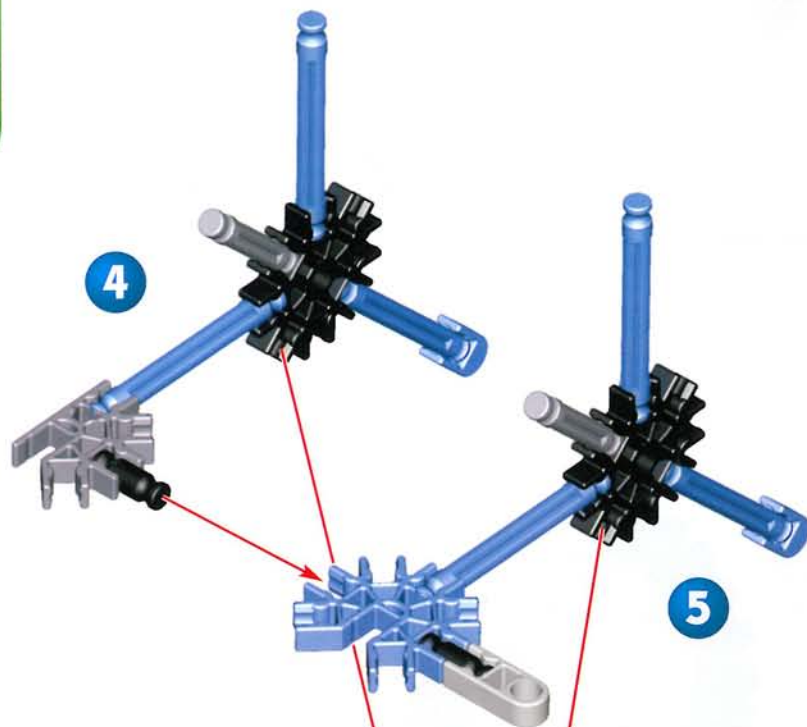

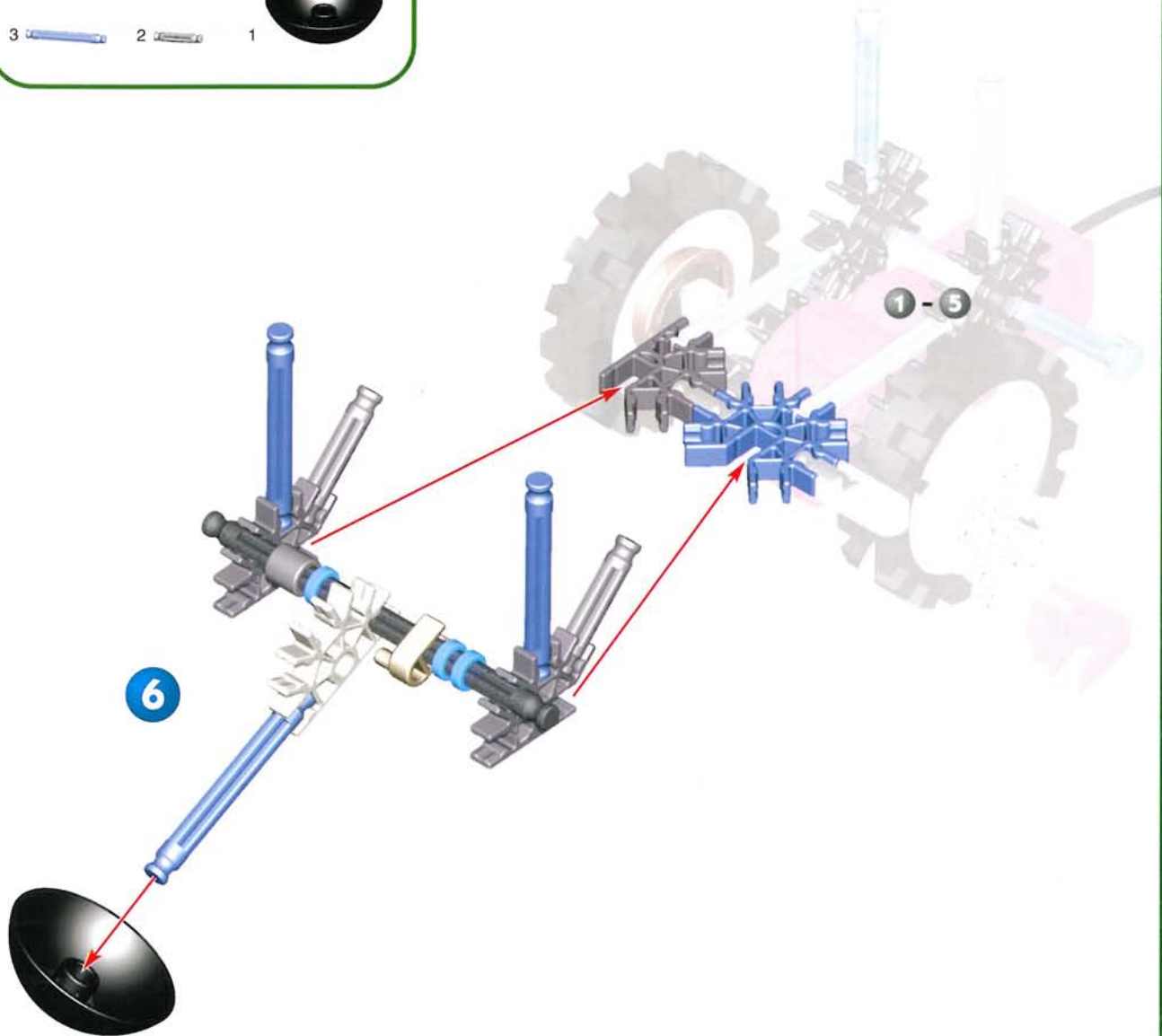

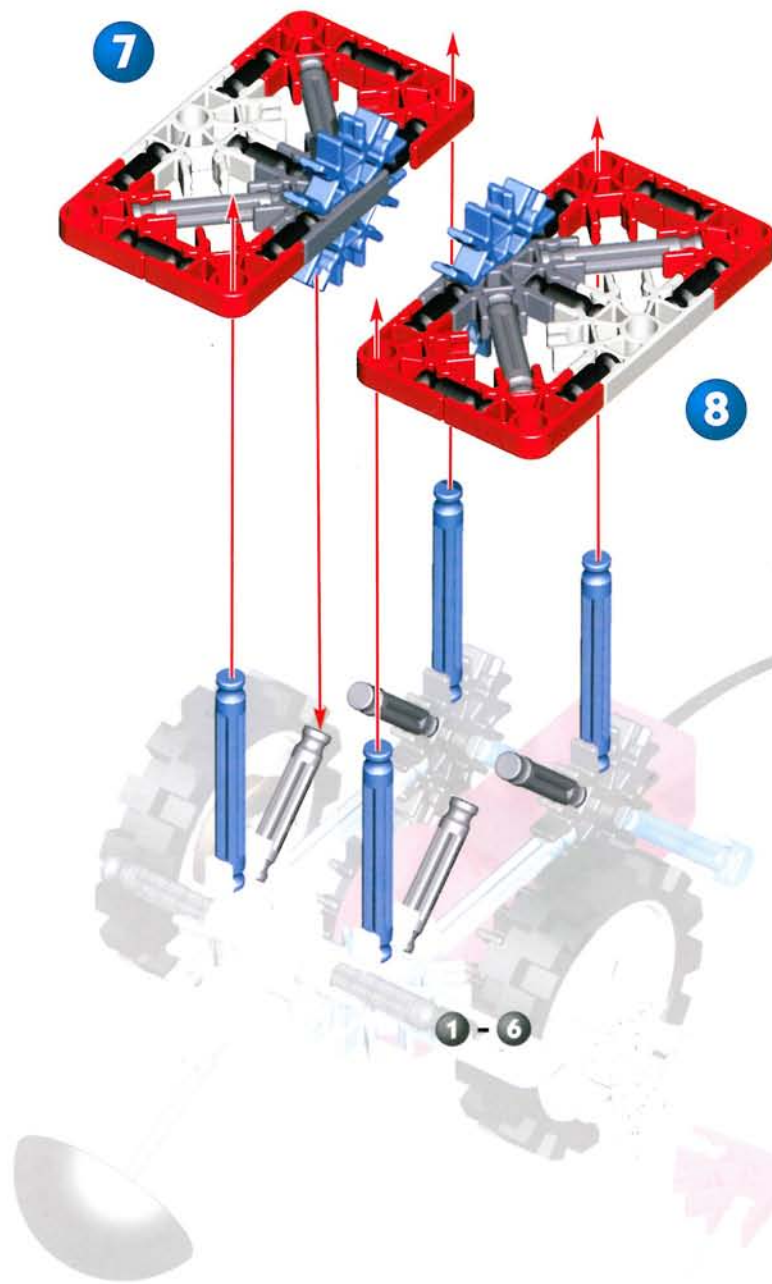

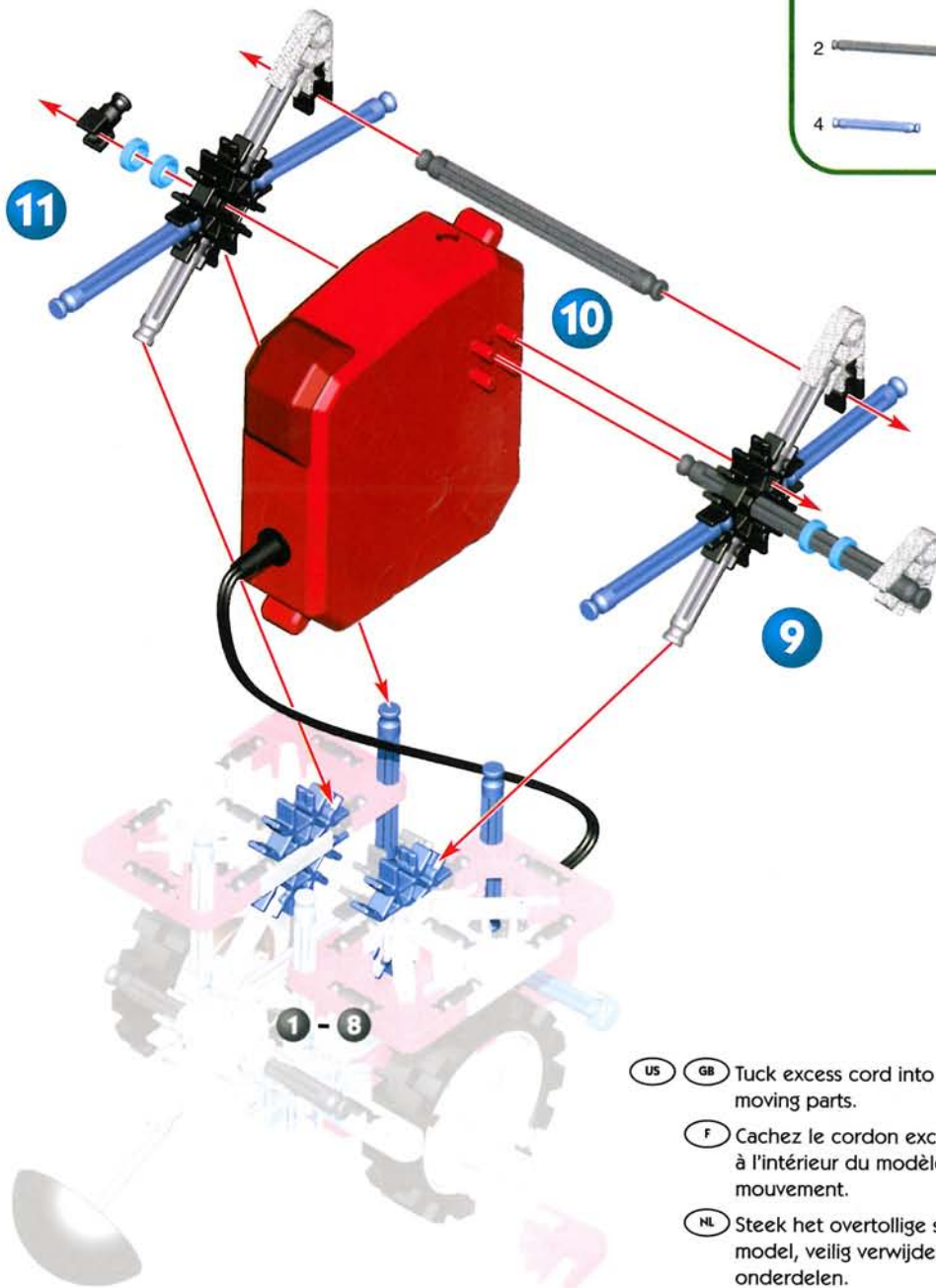

**US** **GB** Tuck excess cord into model, away from all moving parts.

**F** Cachez le cordon excédentaire soigneusement à l'intérieur du modèle, à l'écart des pièces en mouvement.

**NL** Steek het overtollige snoer netjes weg in het model, veilig verwijderd van bewegende onderdelen.

- |   |  |   |  |   |  |
|---|--|---|--|---|--|
| 1 |  | 1 |  | 2 |  |
| 2 |  | 2 |  |   |  |
| 3 |  | 4 |  |   |  |

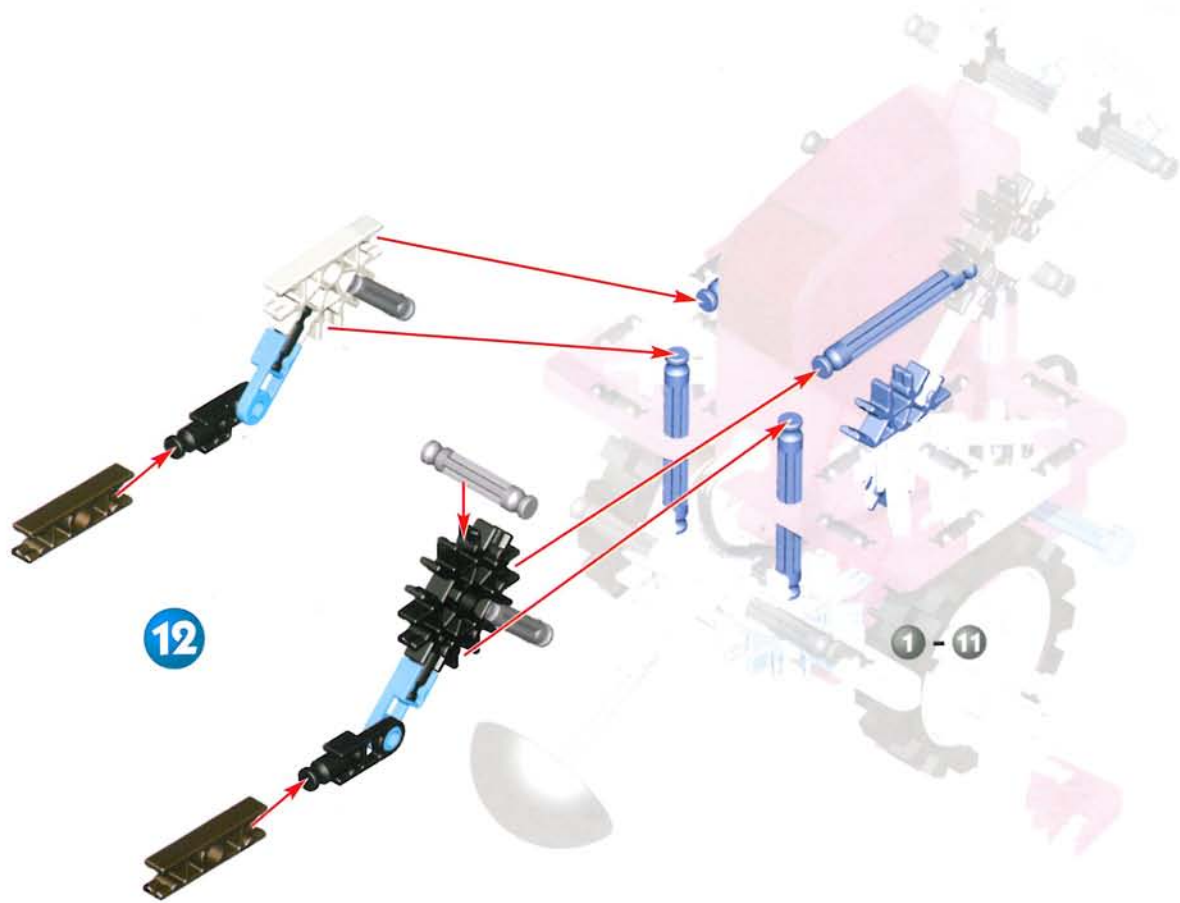

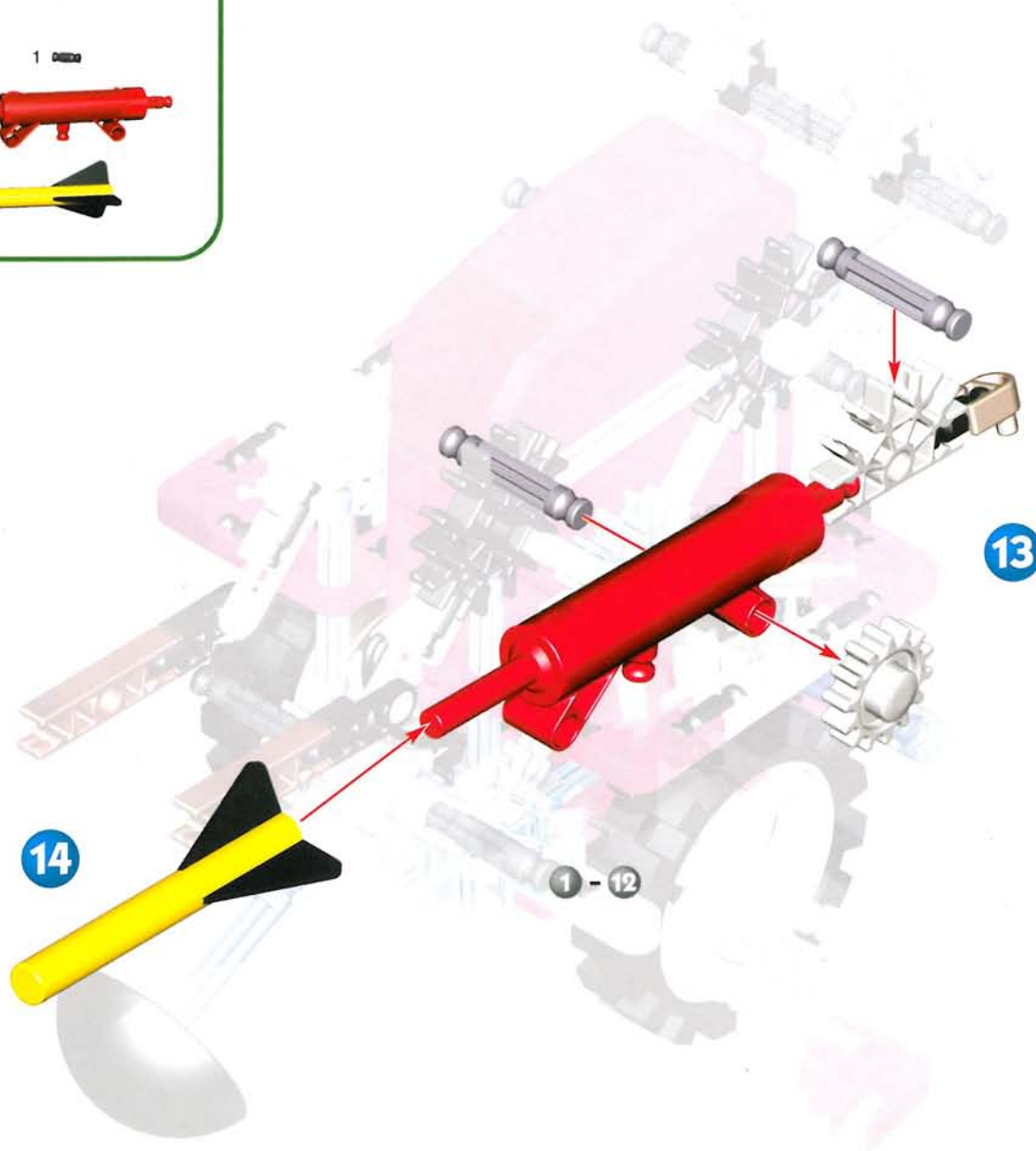

- 2  1  1 
- 1  2  3 
- 1 



- |   |  |   |  |   |  |
|---|--|---|--|---|--|
| 2 |  | 2 |  | 1 |  |
| 2 |  | 2 |  |   |  |
| 2 |  | 2 |  |   |  |
| 2 |  | 2 |  |   |  |

16

18

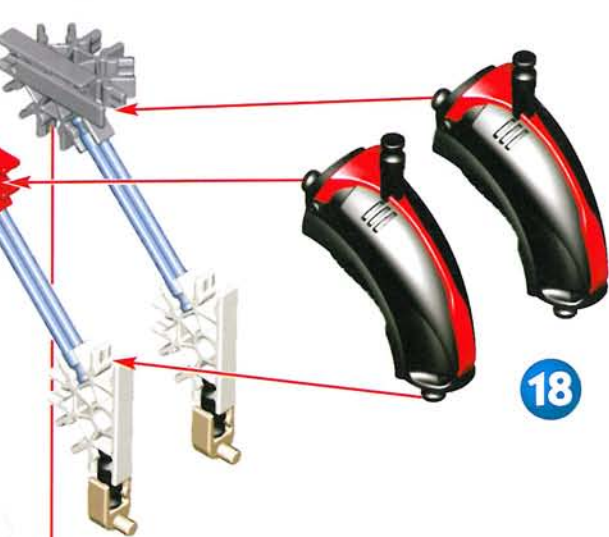

1 - 15

17

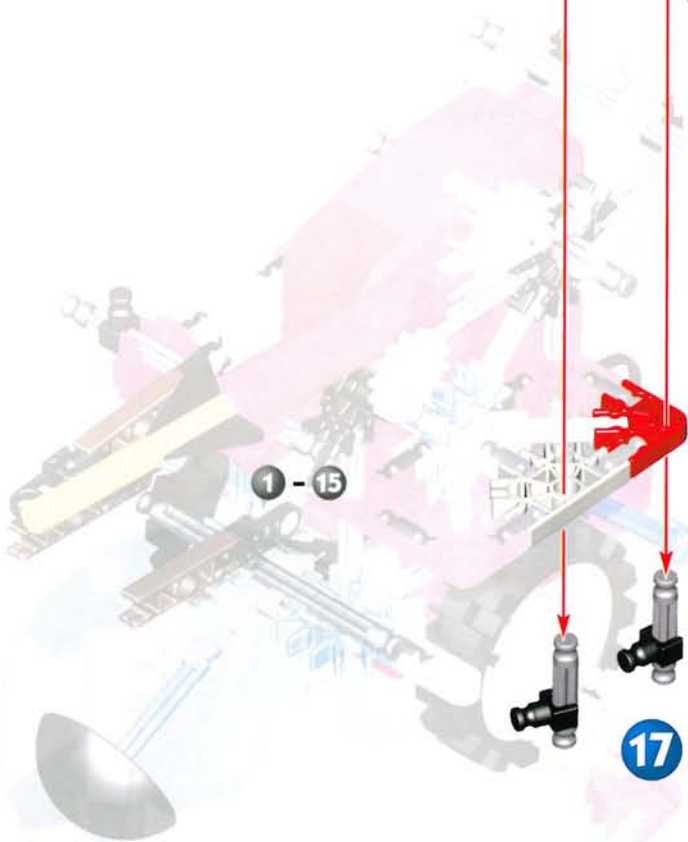

2  1  1 

1  1  

1  1  1 

1  2 

1 

1 

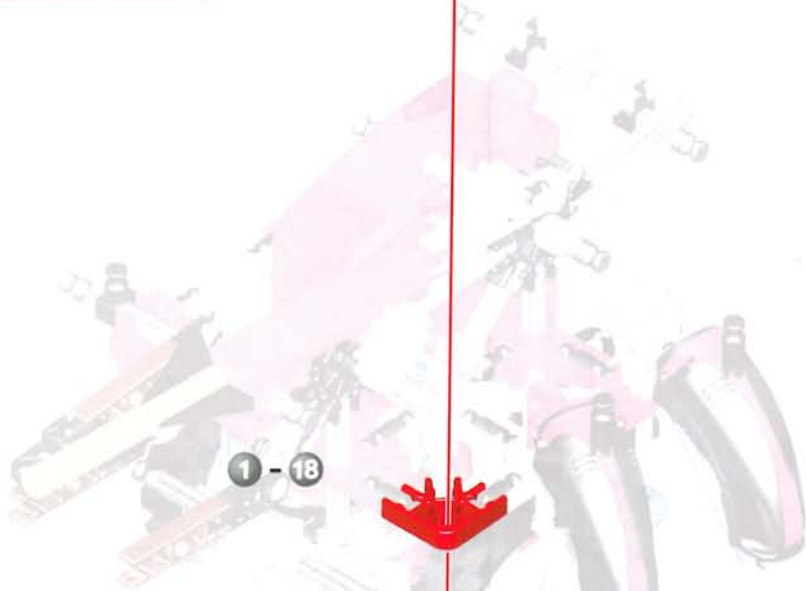
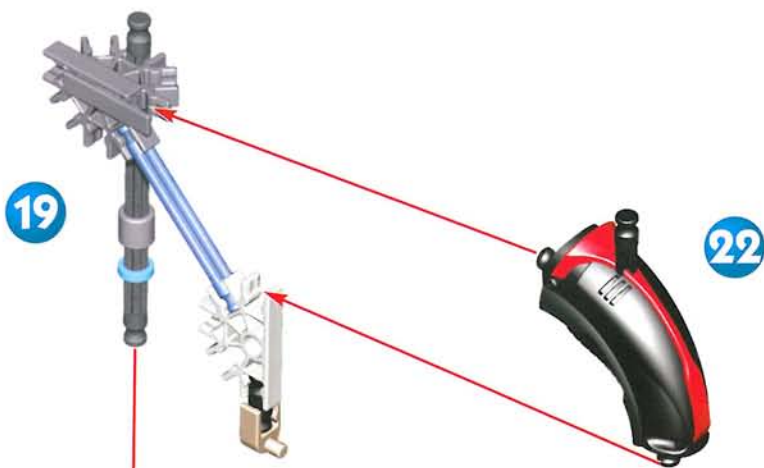

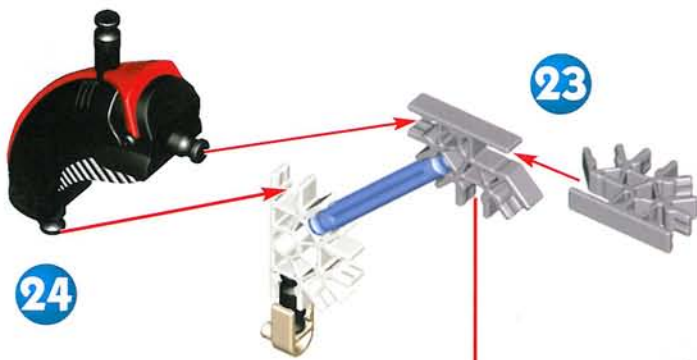

- |   |  |   |  |   |  |
|---|--|---|--|---|--|
| 2 |  | 1 |  | 1 |  |
| 1 |  | 1 |  |   |  |
| 1 |  | 1 |  | 1 |  |

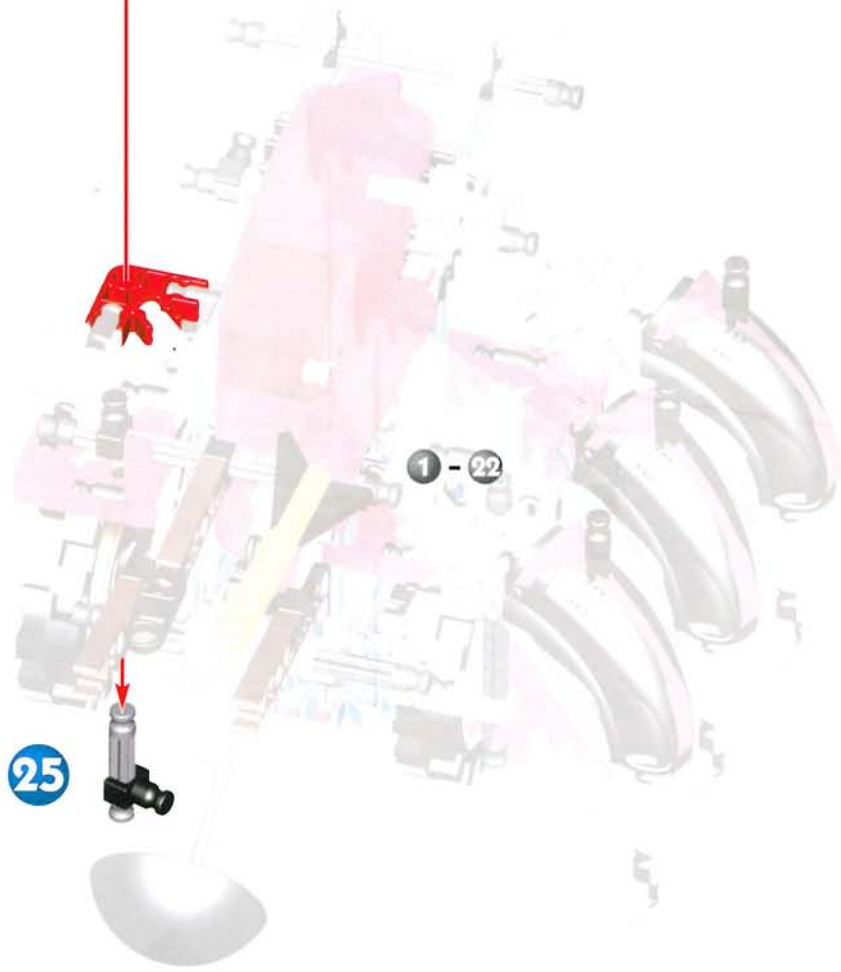

24

23

25

1 - 22

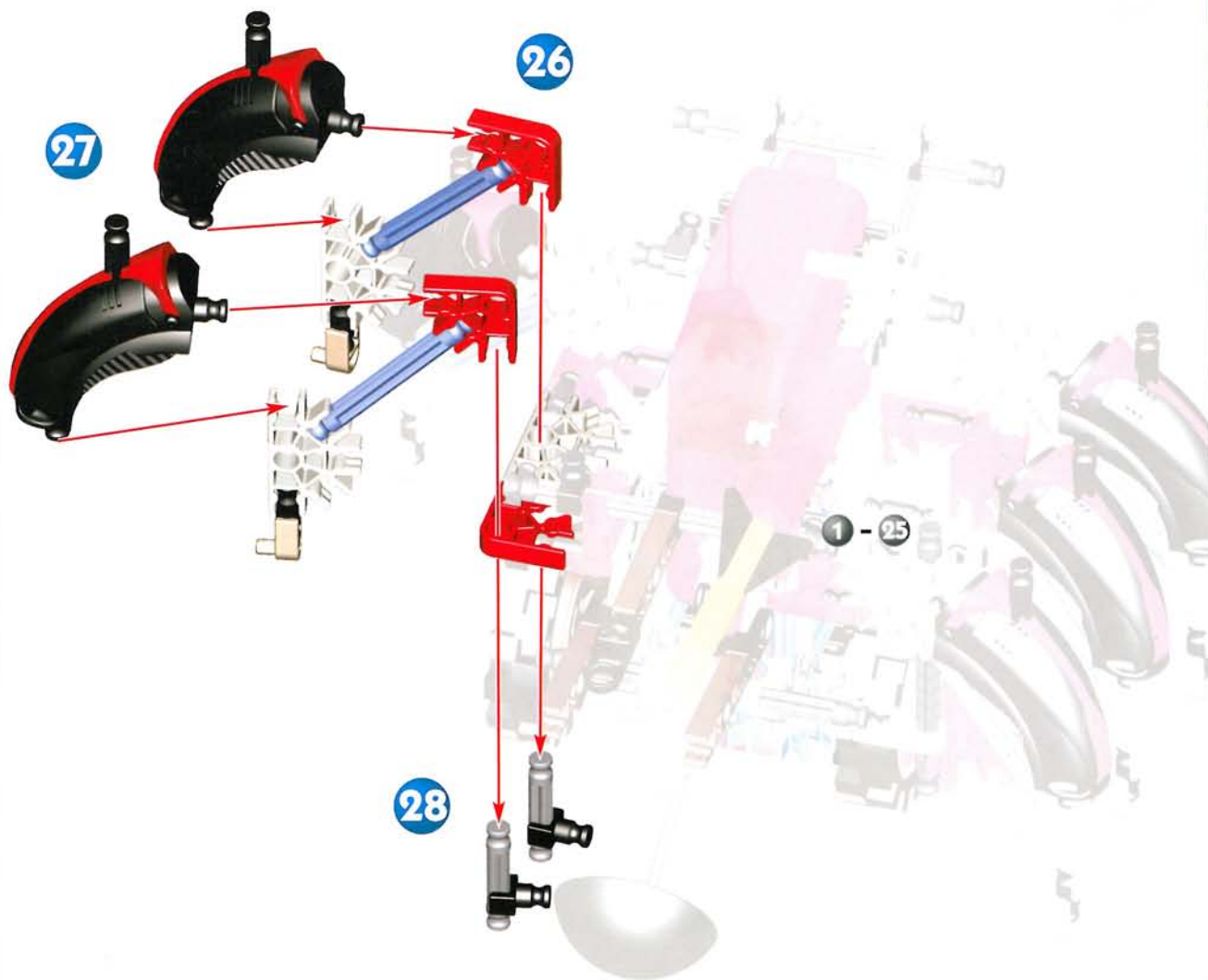

1  2  2 

2  2 

29

1 - 28

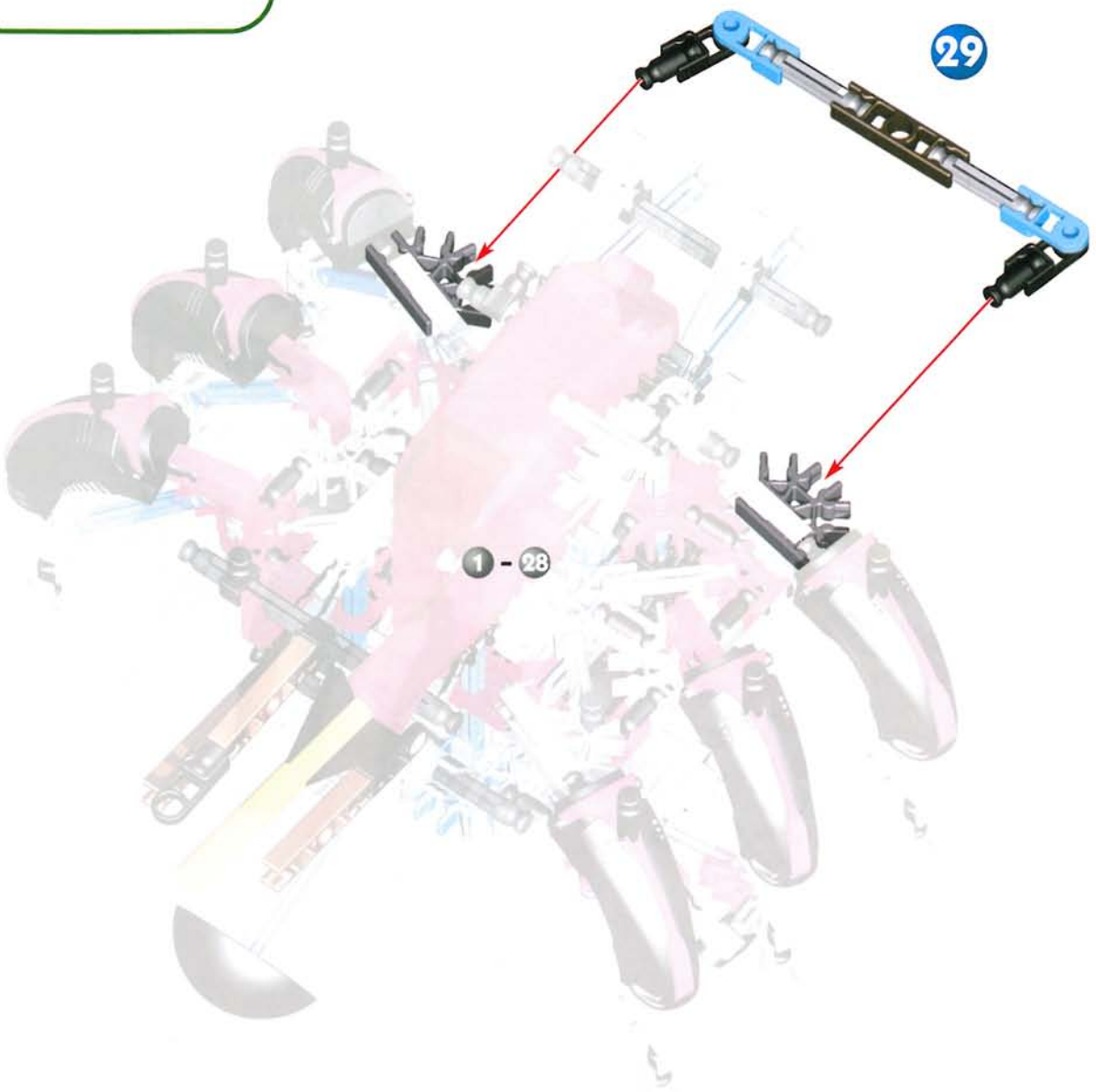

- |   |   |   |   |
|---|---|---|---|
| 4 |  | 4 |  |
| 4 |  | 6 |  |

30



31



1 - 29

1  2 



33

32

34

1 - 31

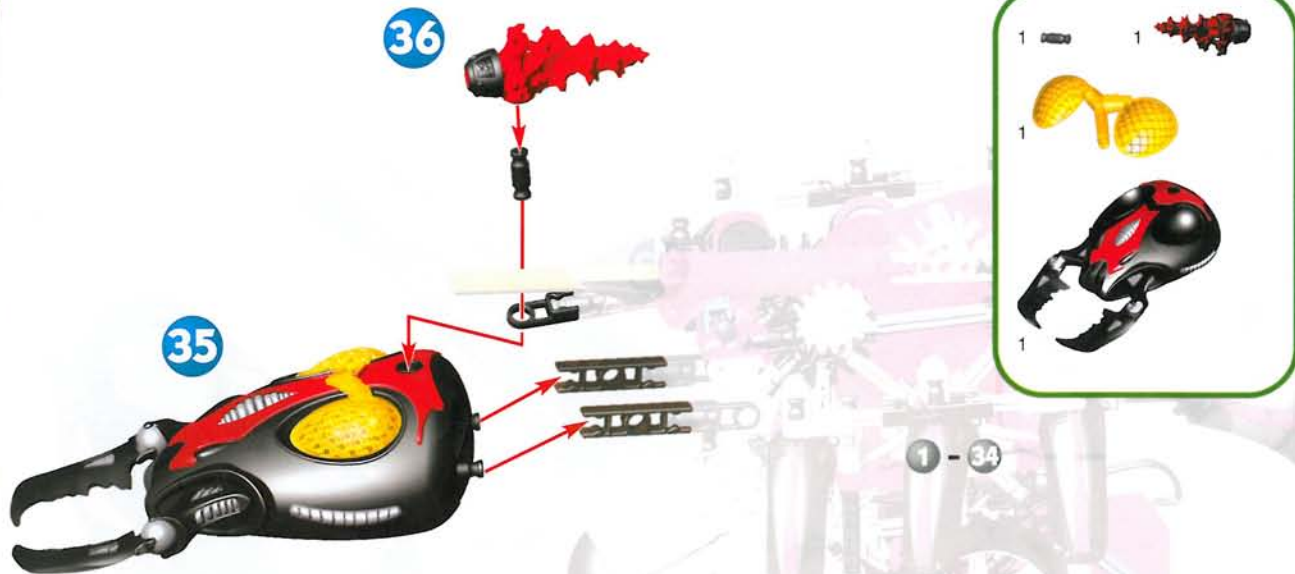

36

35

1

1

1

1

1 - 34



- (US) (GB) To set the Missile Launcher, hook the tip of the bronze Connector over the gray Rod as shown.
- (F) Pour armer le lanceur de missiles, accroche le bout du connecteur bronze sur la tige grise comme indiqué.
- (NL) Om de lanceerinrichting van de raket in te stellen, haak de punt van de bronzen koppelaar over de grijze stang zoals afgebeeld.



1 - 36

DIESEL FIRES ANOTHER MISSILE AT RAVAGE, BUT RAVAGE IS UNHARMED.  
DIESEL TIRE UN SECOND MISSILE EN DIRECTION DE RAVAGE, MAIS RAVAGE N'EST PAS TOUCHÉ.

**GRRZZRT**



RAVAGE PREPARES FOR BATTLE AND CHANGES SHAPE.  
NEED FRENCH NEED FRENCH  
NEED FRENCH



**KRSLAAP**



DIESEL ALSO CHANGES INTO COMBAT MODE, BUT HE DOESN'T NOTICE RAVAGE USING HIS TELEKINESIS POWERCORE TO LIFT A BOULDER...

DIESEL CHANGE LUI AUSSI DE MODE DE COMBAT, MAIS IL NE REMARQUE PAS QUE RAVAGE, SE SERVANT DE SON POWERCORE DE TÉLÉKINÉSIE, SOULÈVE UN ROCHER...

**KKRRRAACCKK**

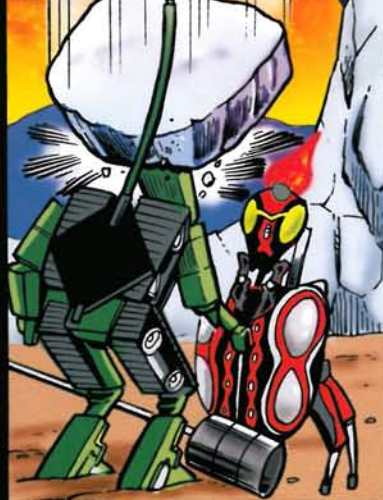

WITH DIESEL UNCONSCIOUS, RAVAGE STEALS HIS ENEMY'S POWERCORE AND MAKES HIS GETAWAY!  
DIESEL INCONSCIENT, RAVAGE VOLE LE POWERCORE DE SON ENNEMI ET DÉCAMPE!







1

1

2

1



2

1

1



1



1

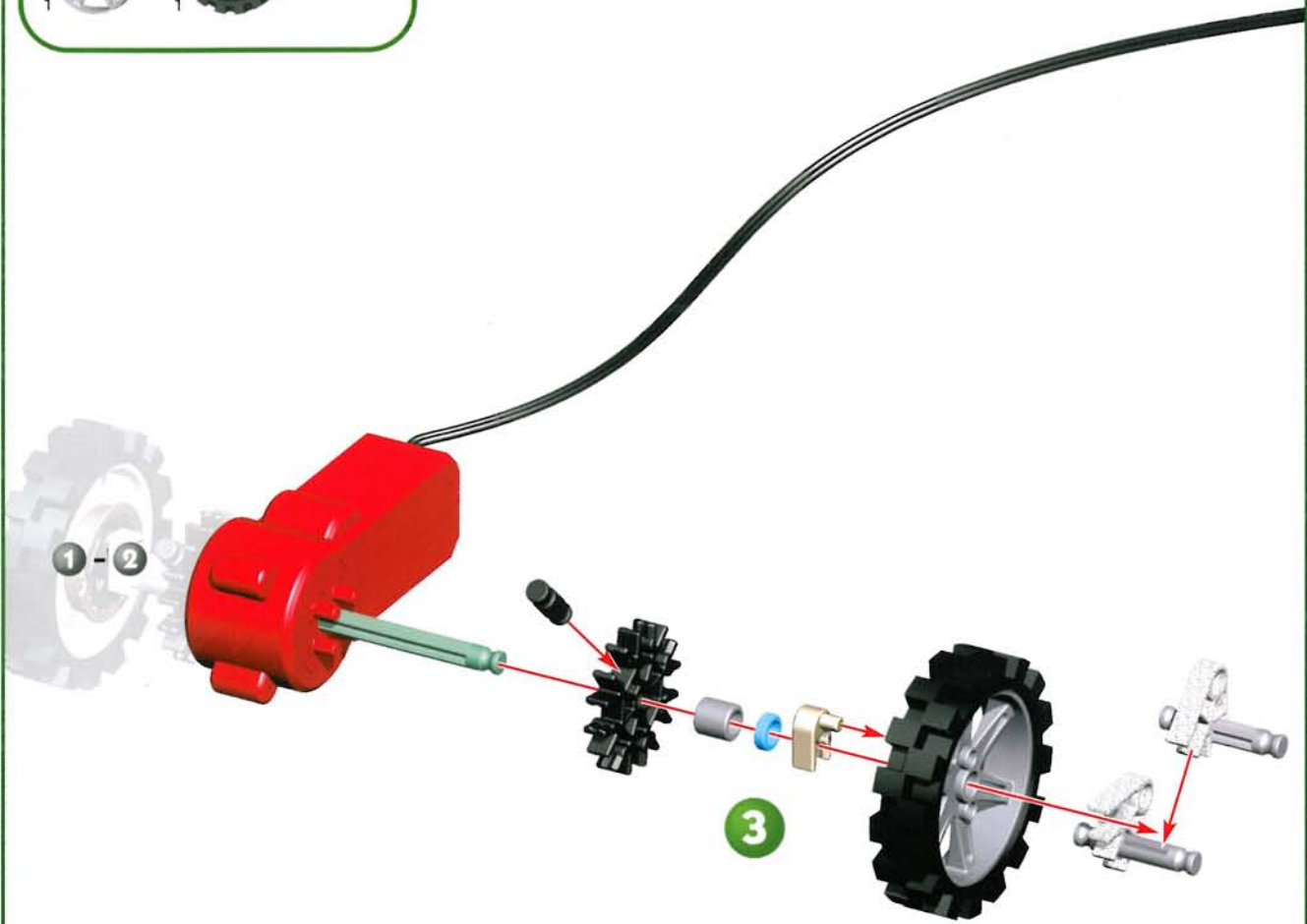

3

- |   |   |   |   |
|---|---|---|---|
| 2 |   | 1 |   |
| 1 |  | 1 |  |
| 2 |  | 6 |  |

4

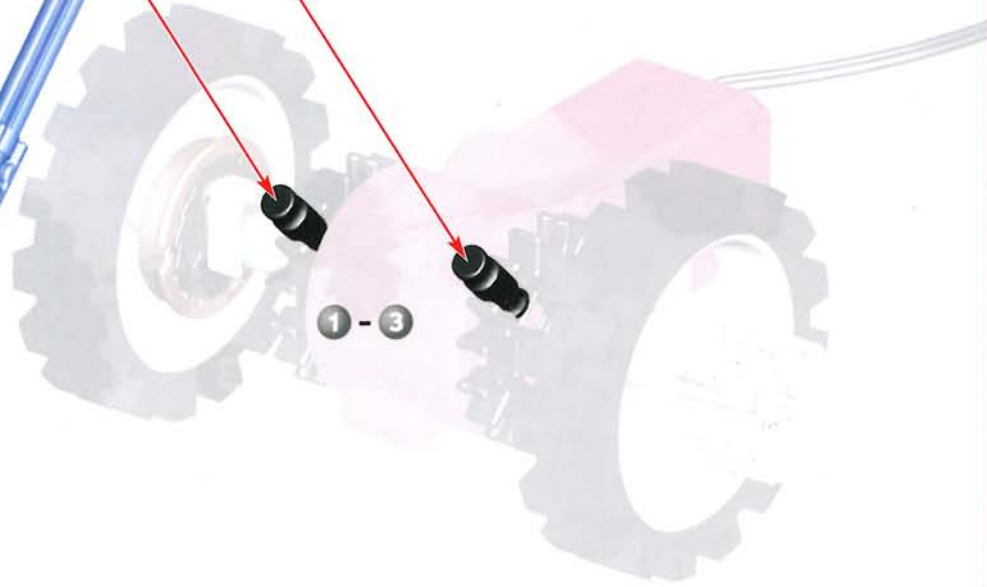
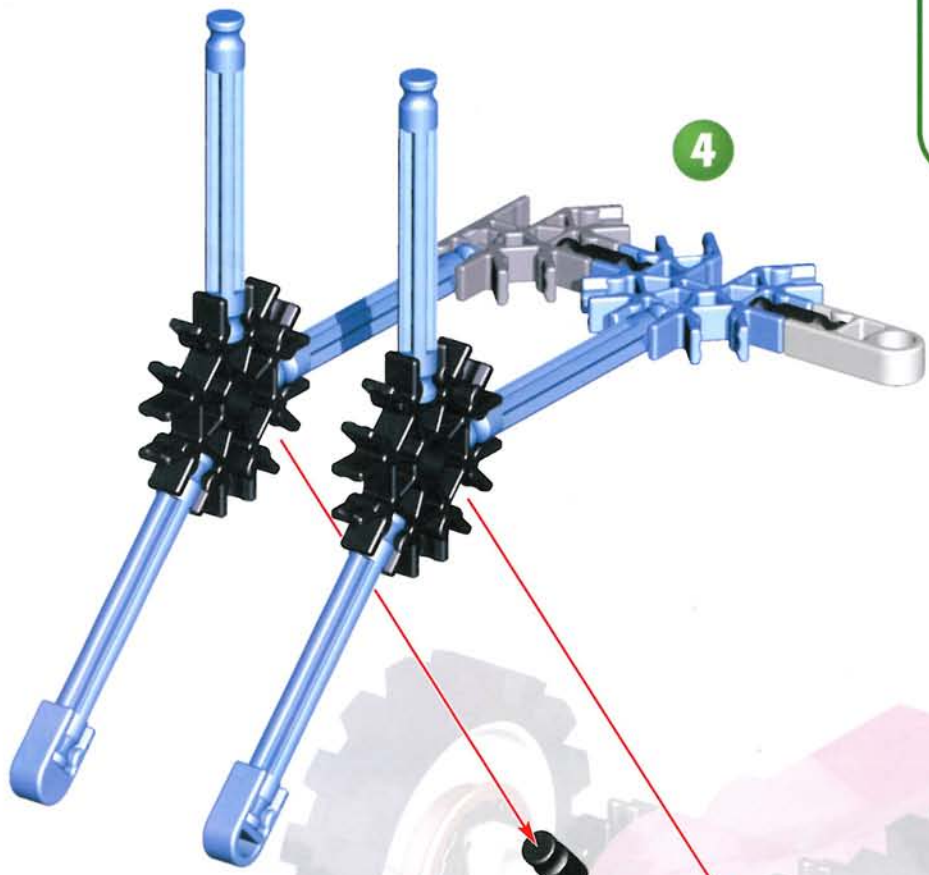

1-3

- 1  1 
- 2  3  1 
- 3  1 
- 1 

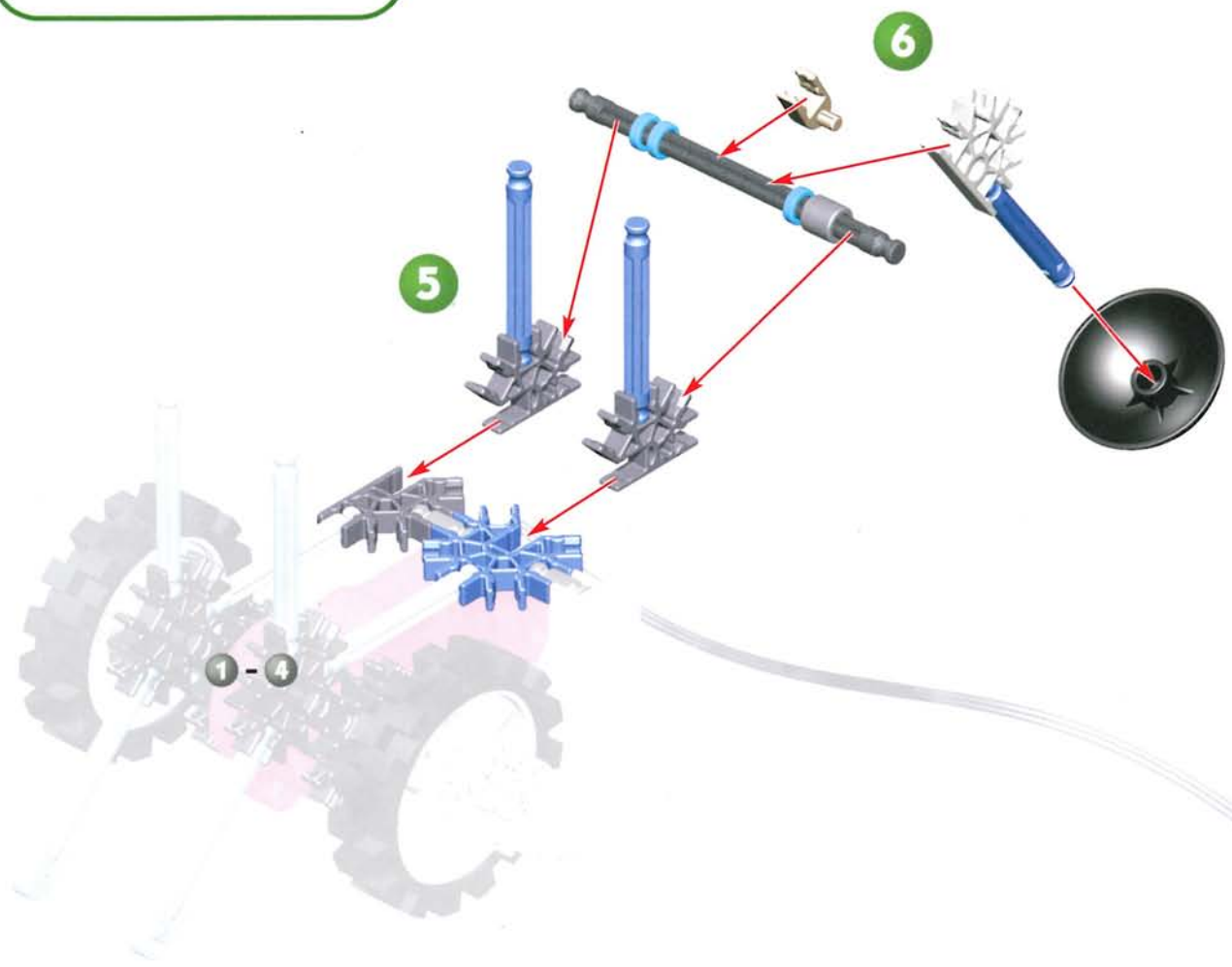



- 1  4 
- 1  4 
- 4 

8

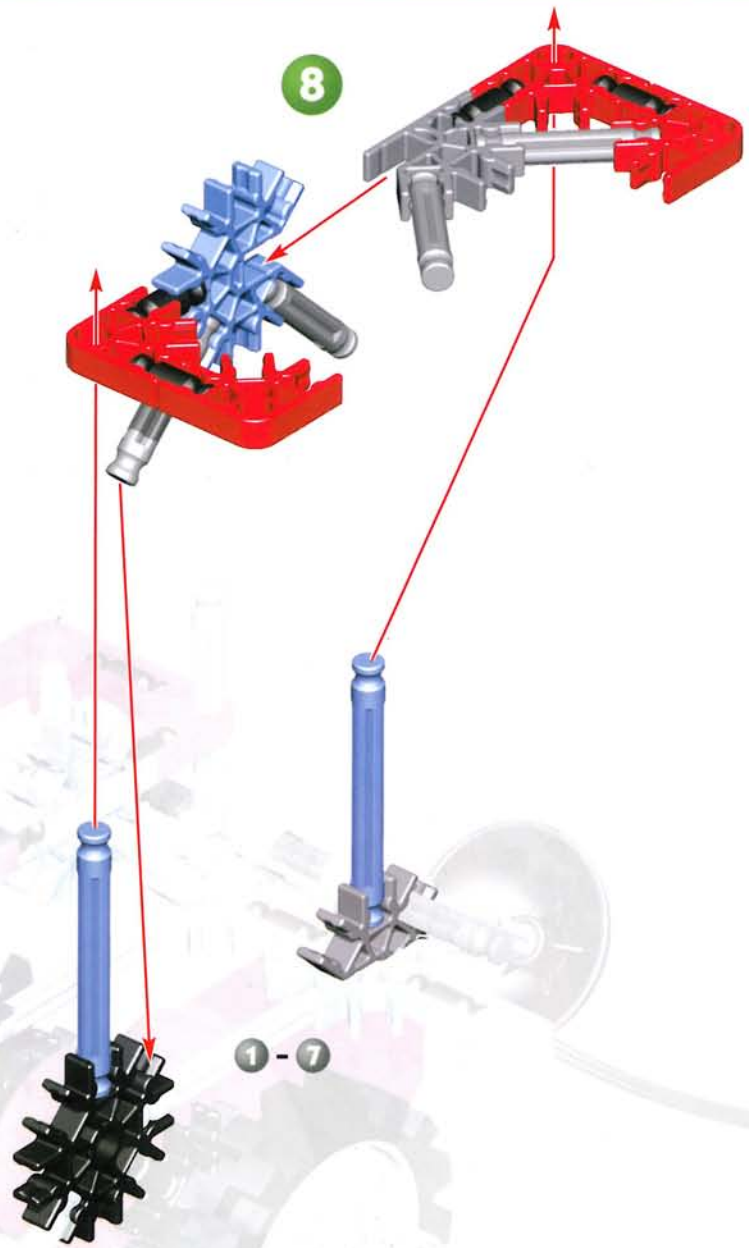

1 - 7

- |   |  |   |   |
|---|--|---|---|
| 1 |   | 1 |  |
| 2 |  | 2 |  |
| 1 |  | 1 |  |
| 1 |  | 1 |  |
| 1 |  |   |   |

1 - 8

9

10

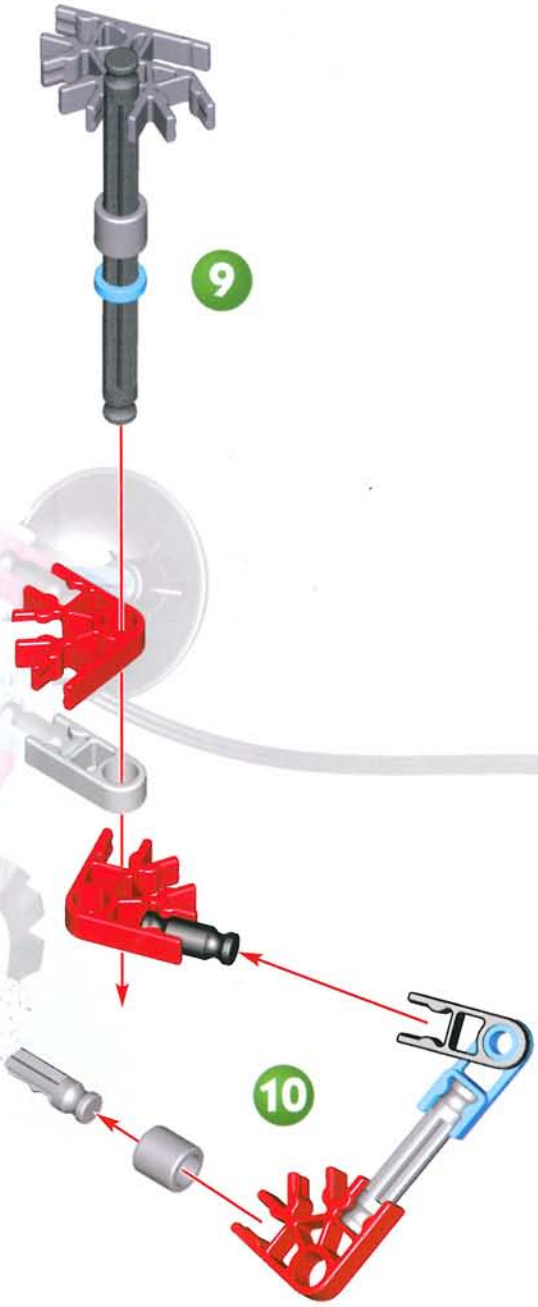

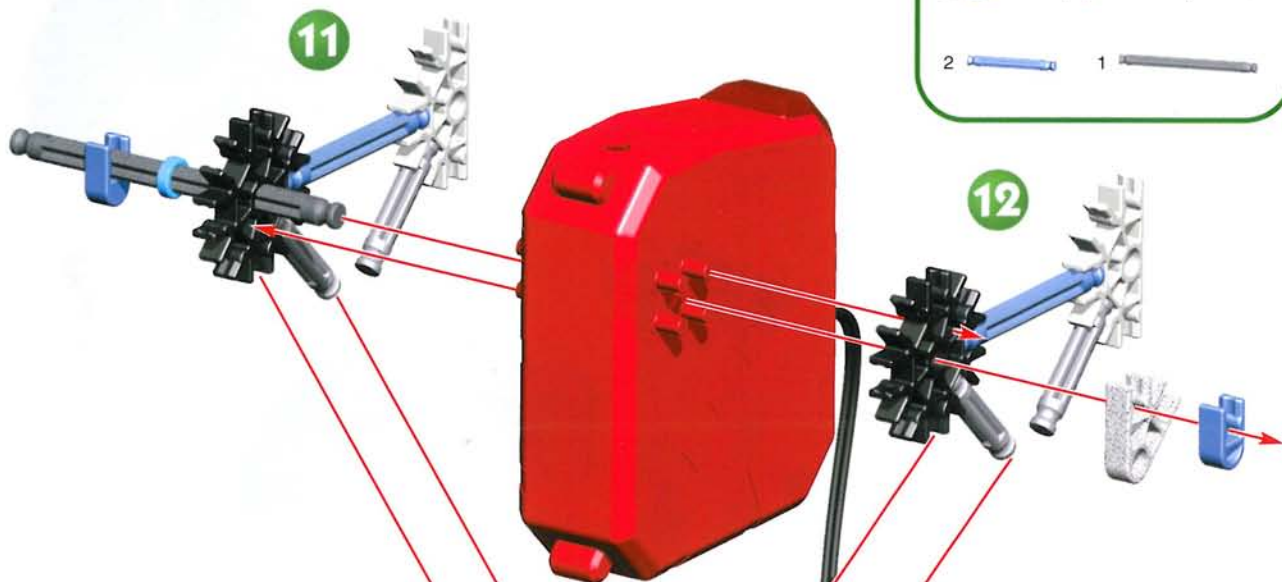
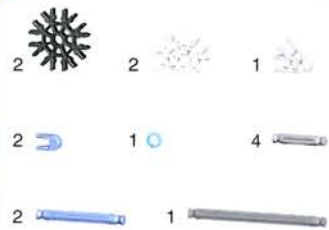

12

- (US) (GB) Tuck excess cord into model, away from all moving parts.
- (F) Cachez le cordon excédentaire soigneusement à l'intérieur du modèle, à l'écart des pièces en mouvement.
- (NL) Steek het overtollige snoer netjes weg in het model, veilig verwijderd van bewegende onderdelen.

1 - 10

- |   |  |   |   |   |  |
|---|--|---|---|---|--|
| 1 |   | 2 |   | 2 |  |
| 1 |  | 2 |  |   |  |
| 2 |  | 1 |  |   |  |
| 2 |  | 2 |  |   |  |

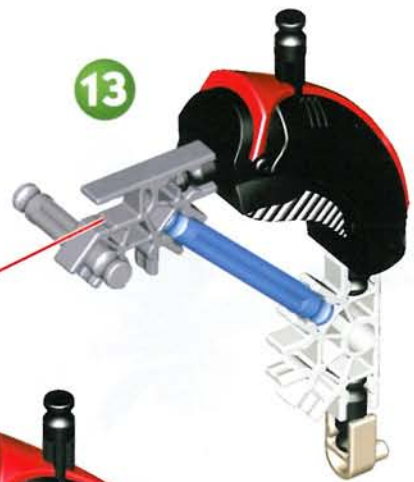

13



1 - 12



14



15

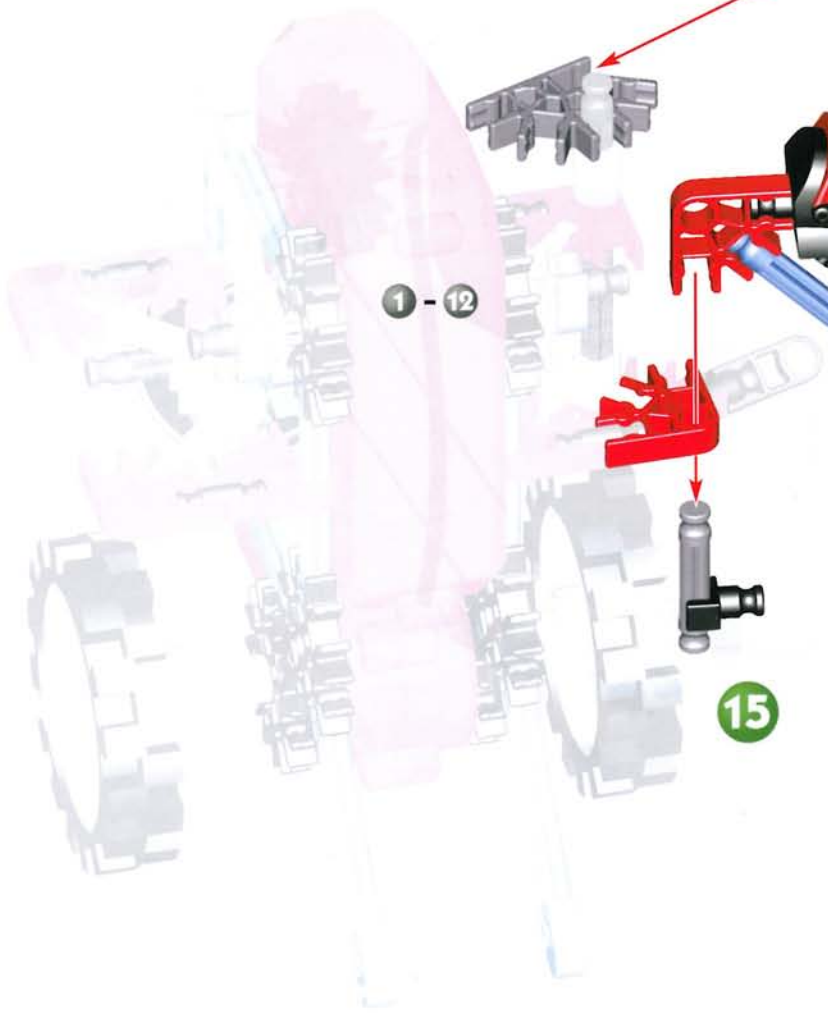



16

- |   |  |   |  |   |  |
|---|--|---|--|---|--|
| 2 |  | 2 |  | 2 |  |
| 1 |  | 2 |  |   |  |
| 3 |  | 2 |  |   |  |
| 2 |  | 2 |  |   |  |



18



17



19

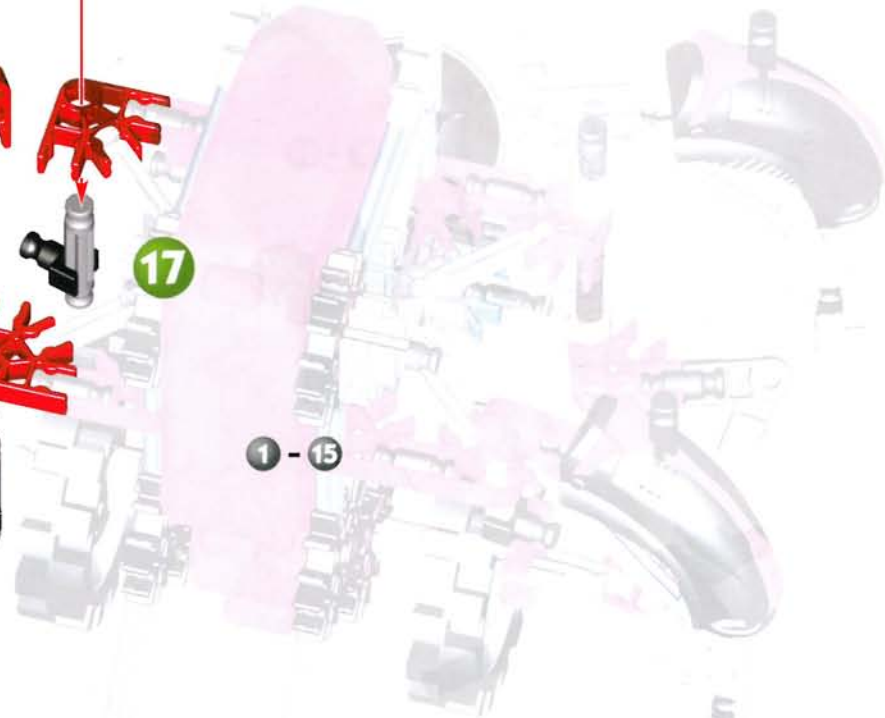

1 - 15

- 4  2 
- 2  2 
- 4 
- 1 

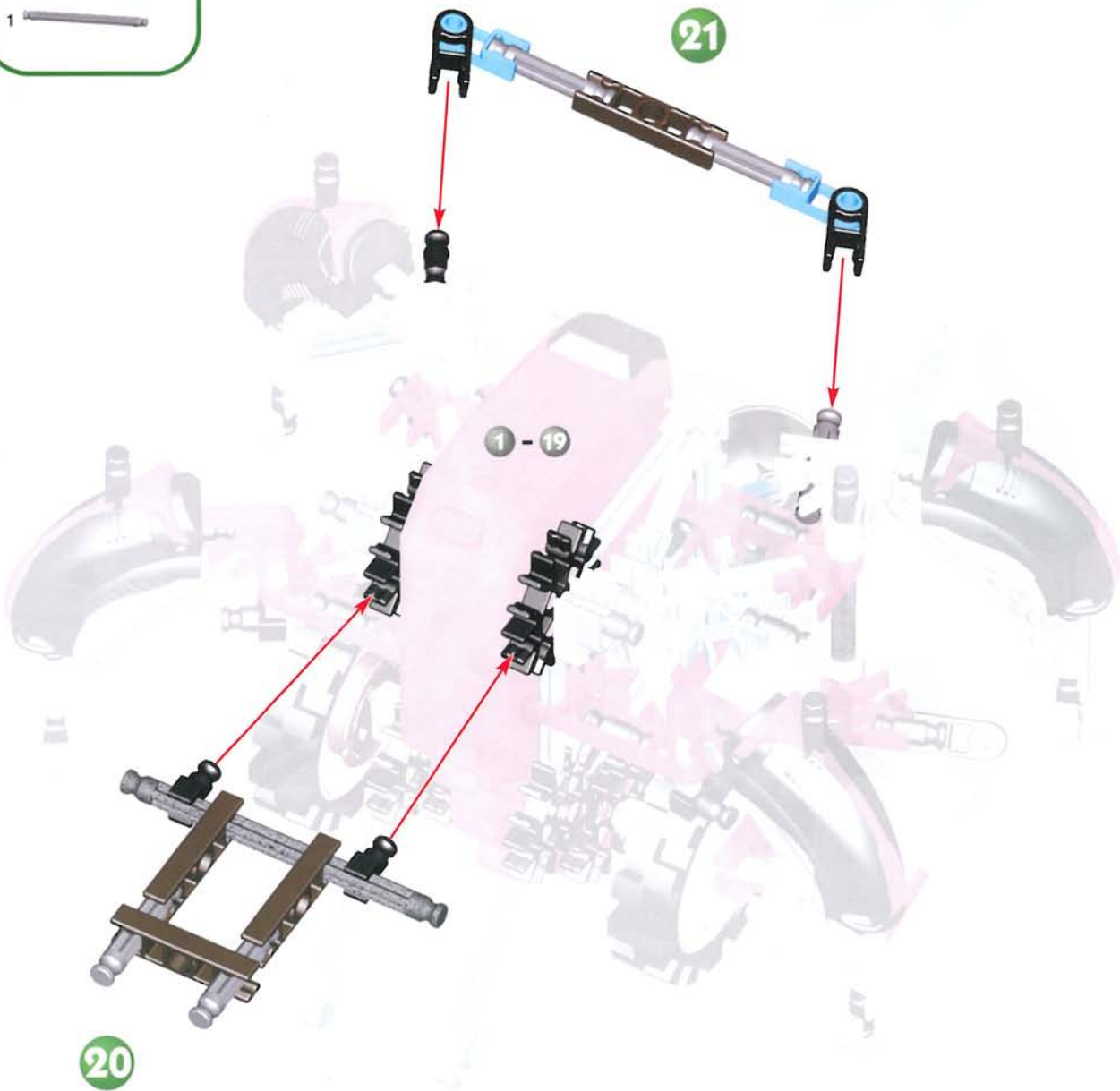

2 

4 

4 

4 

22

23

1 - 21



24

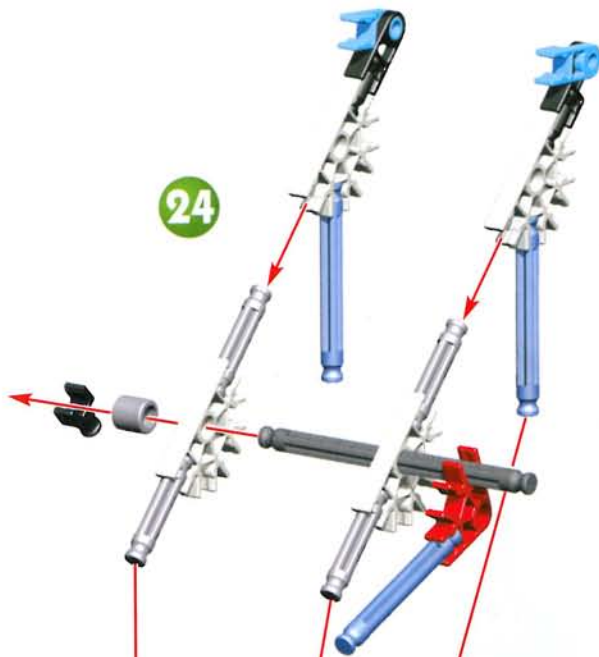

- |   |  |   |  |
|---|--|---|--|
| 4 |  | 1 |  |
| 1 |  | 2 |  |
| 4 |  | 2 |  |
| 3 |  | 1 |  |
| 1 |  | 2 |  |

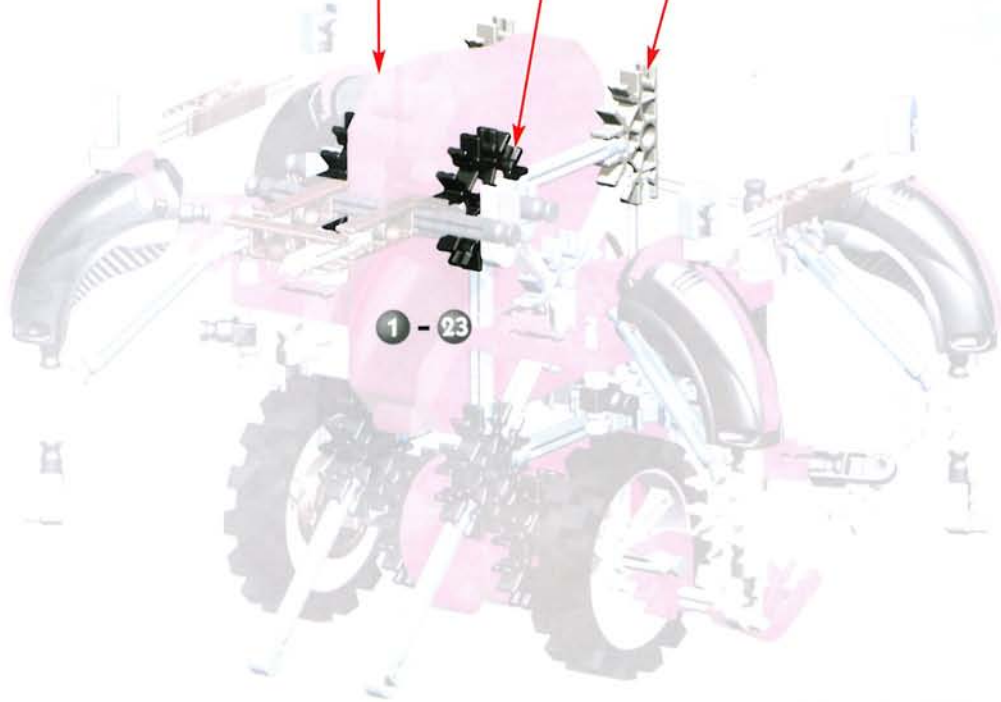

- 1 
- 2 
- 1 
- 3 
- 1 



25

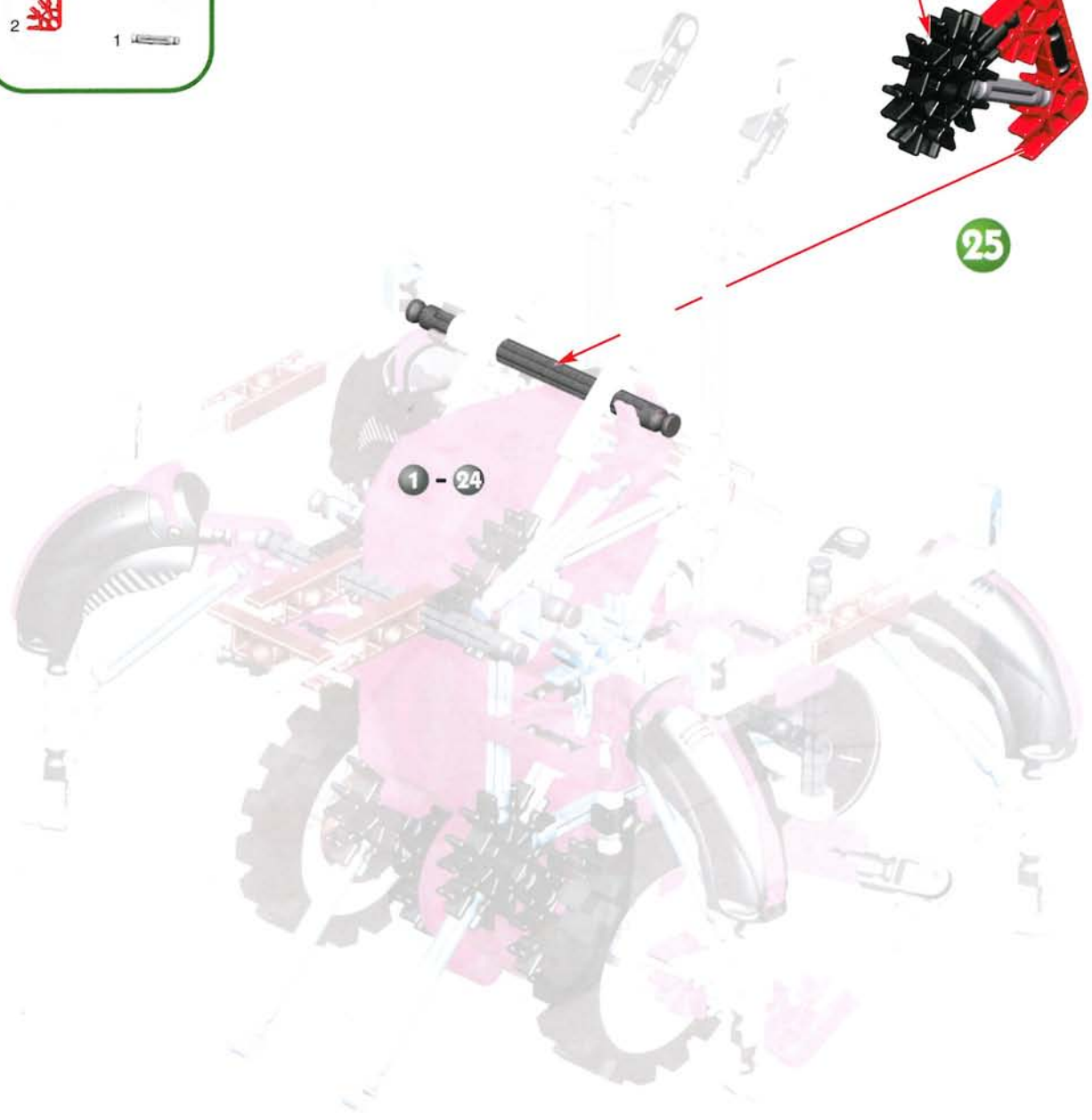

1 - 24

1

2



1 - 25



26

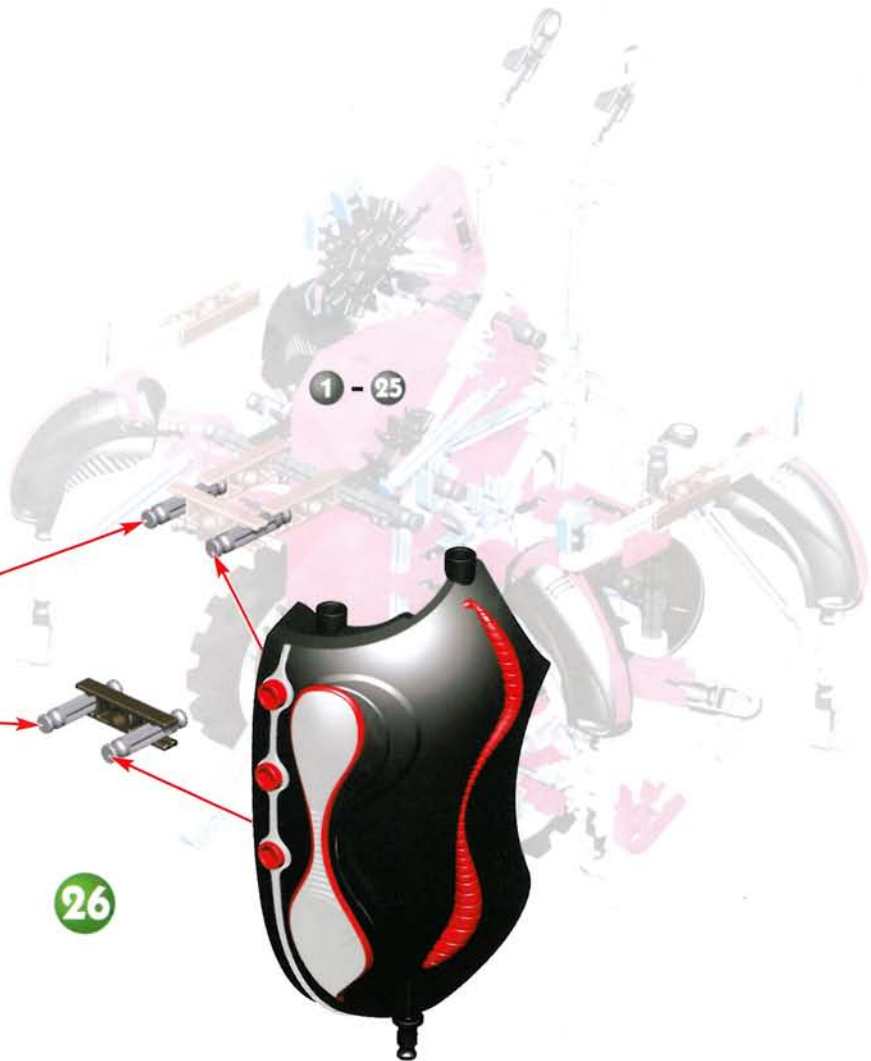

2



1

1



1



1

27



28

1 - 26

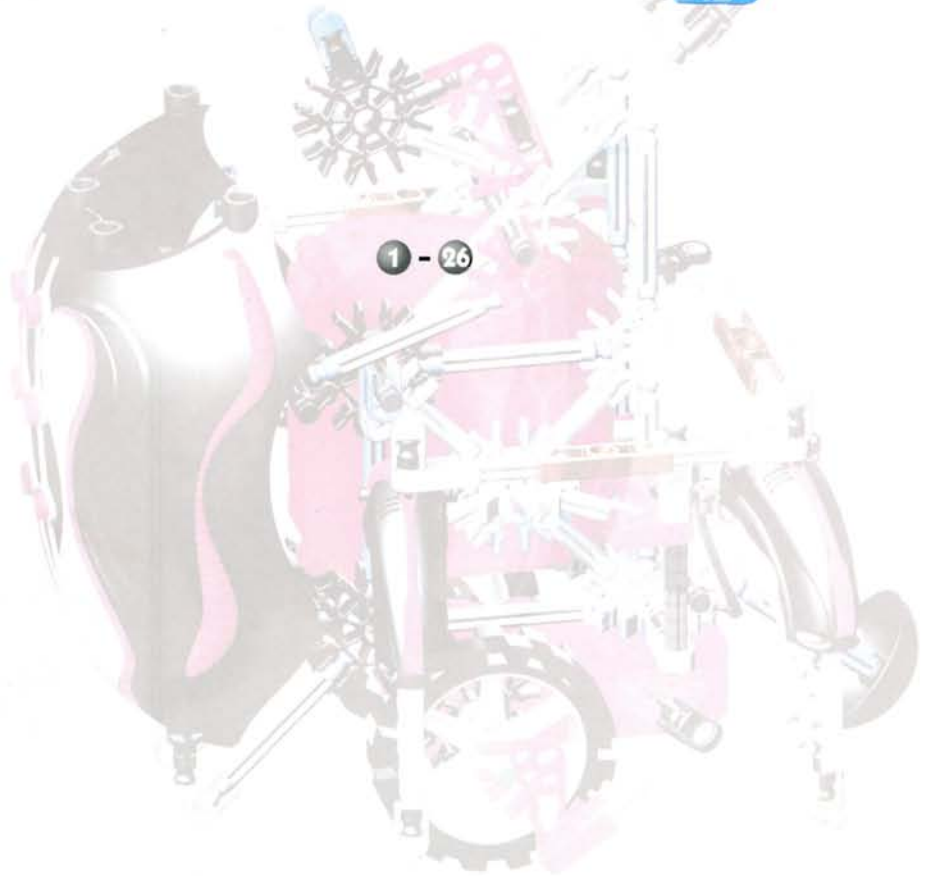

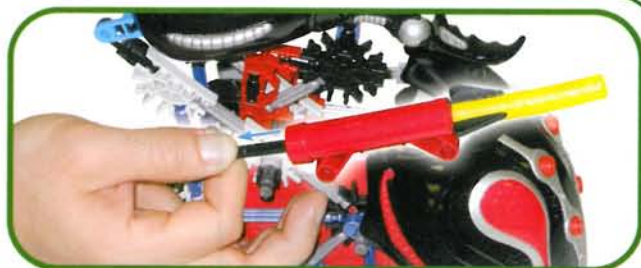

29



1 - 28



1 - 29



RAVAGE, SEEING THAT HIS ALLIES HAVE ALSO BEEN VICTORIOUS, CHANGES SHAPE AND LEADS HIS TEAM AWAY.  
RAVAGE, CONSTATANT QUE SES ALLIÉS SONT ELUX AUSSI VICTORIEUX, CHANGE DE FORME ET ENTRAÎNE SON ÉQUIPE.



RAVAGE AND HIS FELLOW ZEKORIAN CREATURES LEAVE THE BATTLEFIELD TO PLOT NEW, EVEN MORE DEADLY SCHEMES TO GAIN ULTIMATE POWER!  
RAVAGE ET SES CO-CRÉATURES ZEKORIAN ABANDONNENT LE CHAMP DE BATAILLE APIN DE MANIGANCER DES COMLOTS ENCORE PLUS REDOUTABLES EN VUE DE REMPORTEUR LE POUVOIR SUPRÊME !

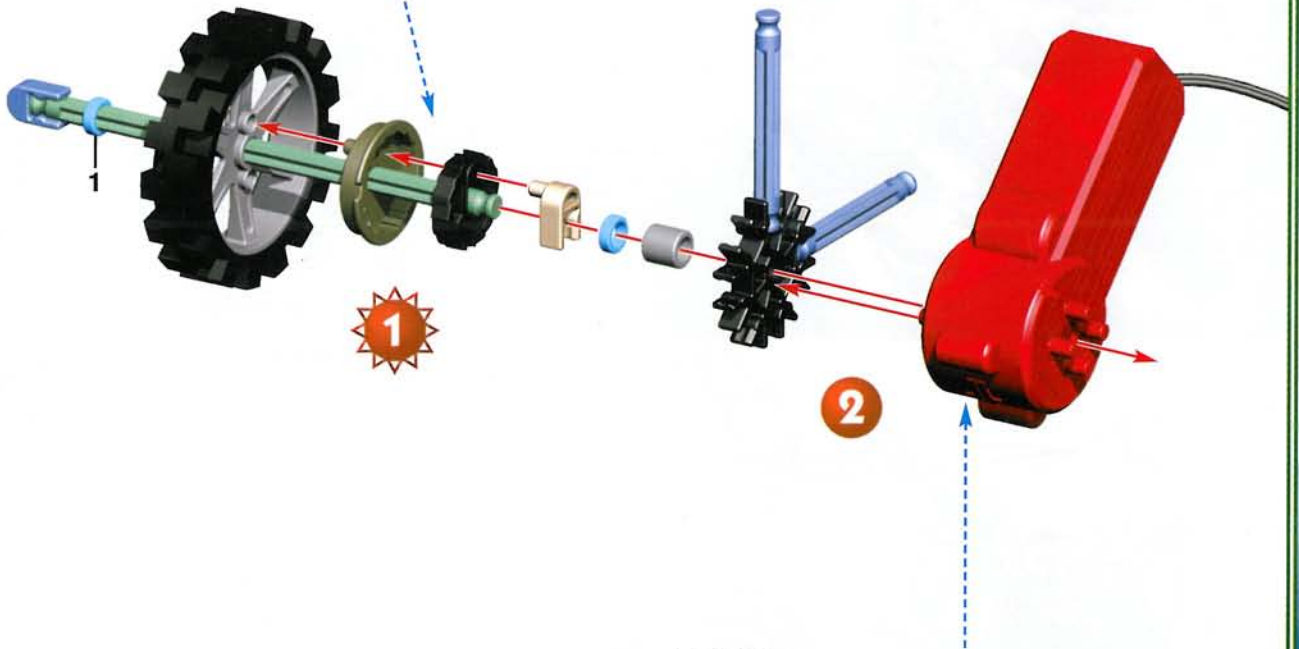
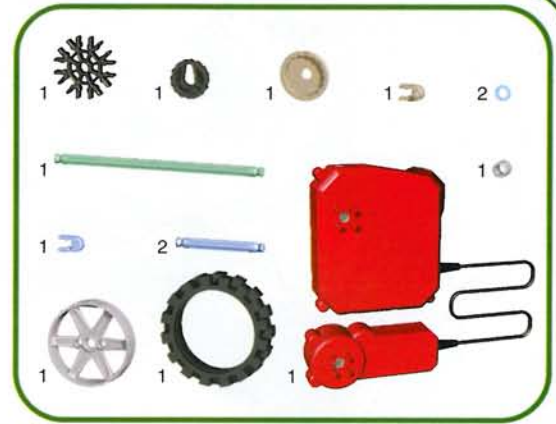
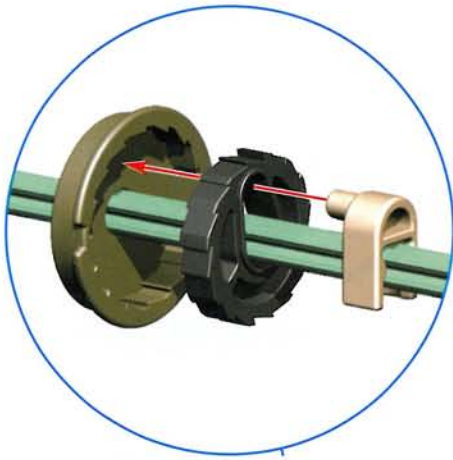

- (US) (GB) Arrow on motor must point down.  
 (F) La flèche sur le moteur doit être dirigée vers le bas.  
 (NL) De motorpijl moet naar onder gericht zijn.

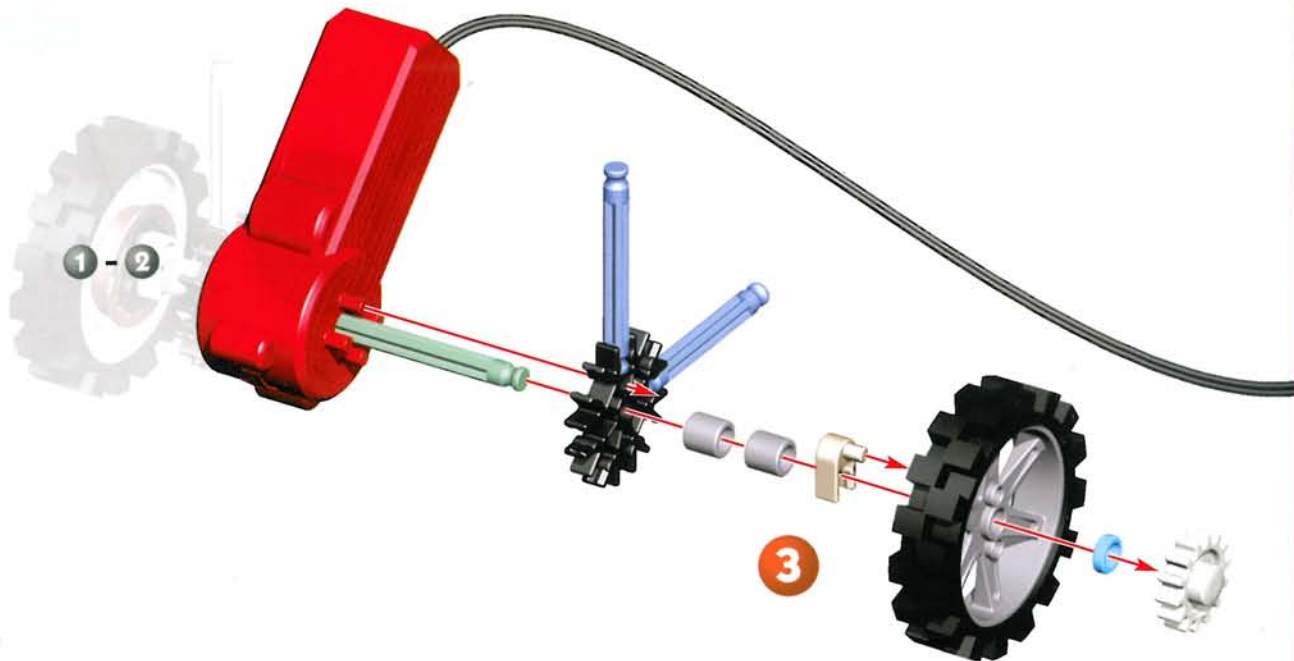

- |   |  |   |  |   |
|---|--|---|--|---|
| 4 |  | 1 |  |   |
| 2 |  | 1 |  | 1 |
| 2 |  |   |  |   |
| 1 |  |   |  |   |

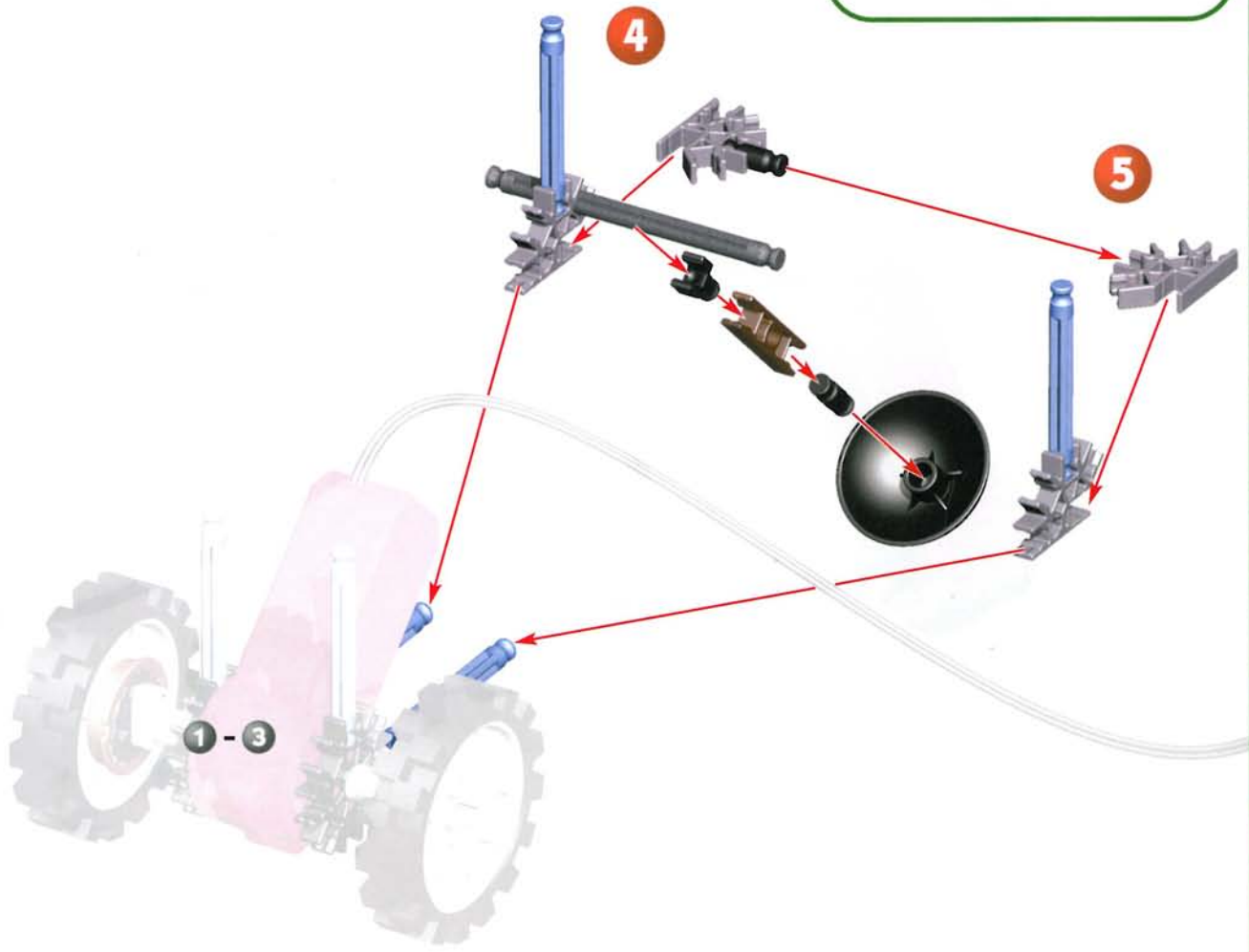

- 2 
- 4 
- 2 

- 4 
- 4 



6

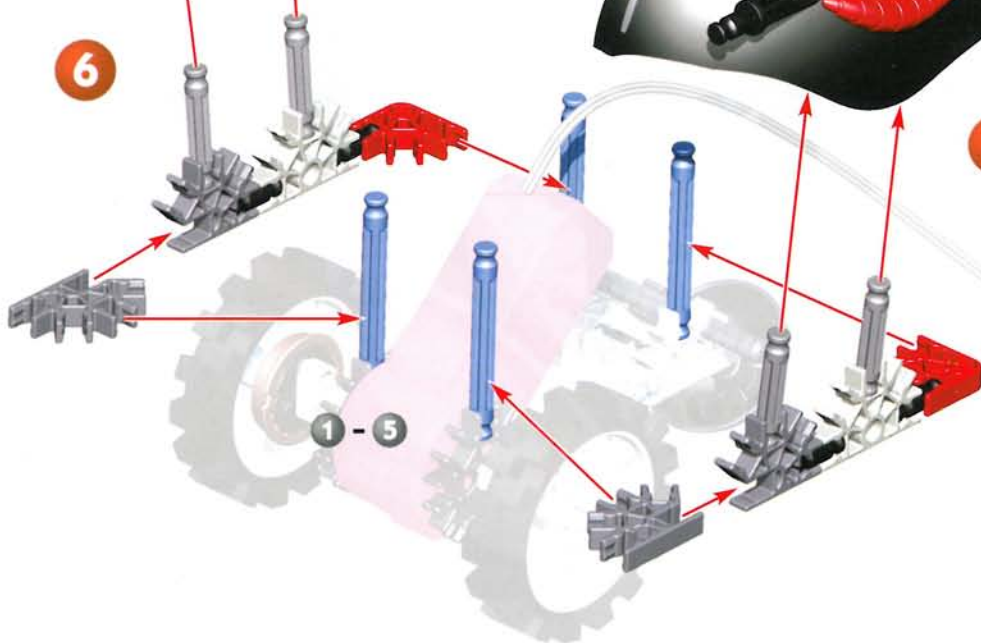

7

- |   |  |   |  |   |  |
|---|--|---|--|---|--|
| 1 |  | 1 |  | 2 |  |
| 1 |  | 3 |  | 1 |  |
| 3 |  | 2 |  |   |  |
| 2 |  | 2 |  |   |  |

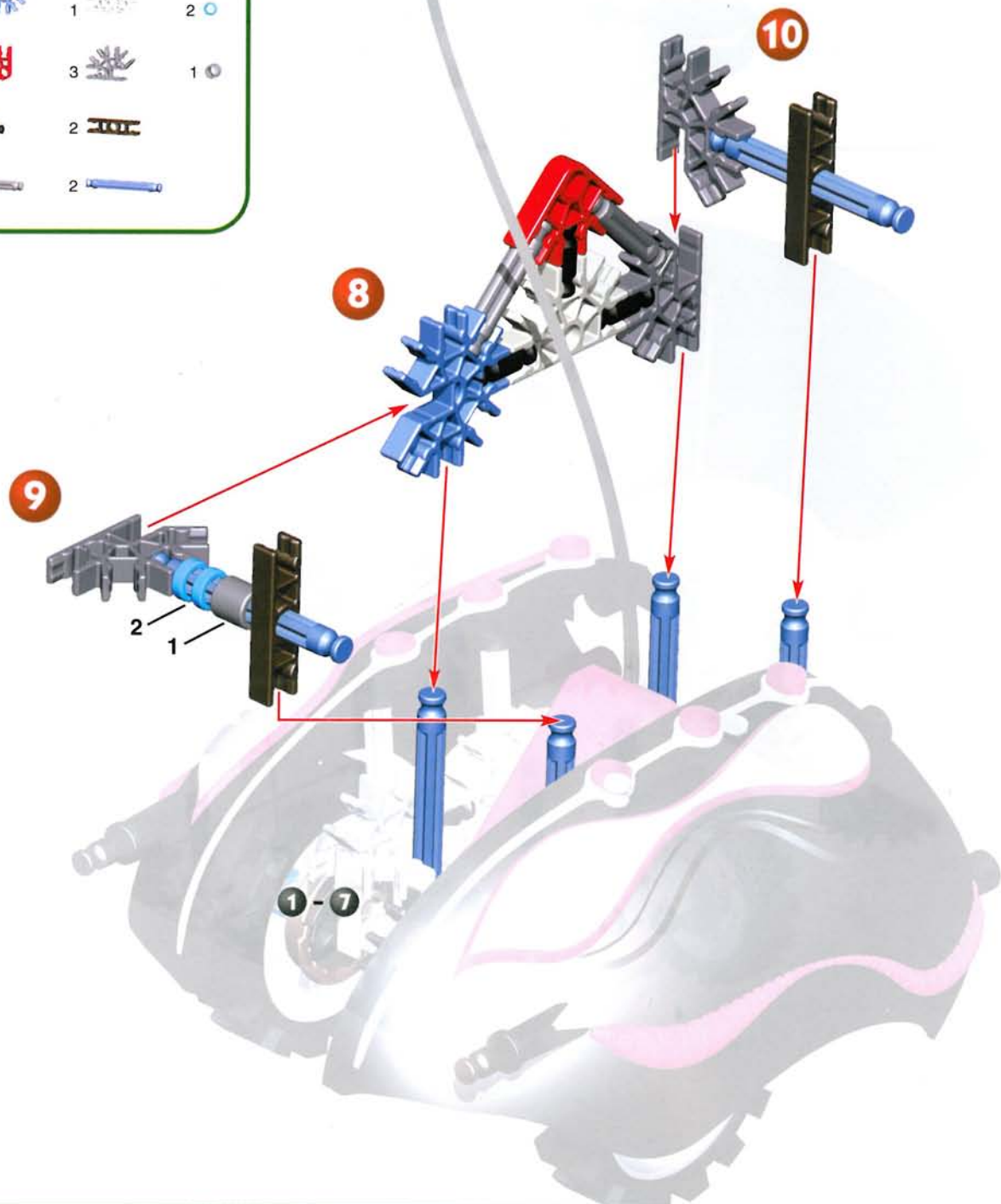



1



3



1

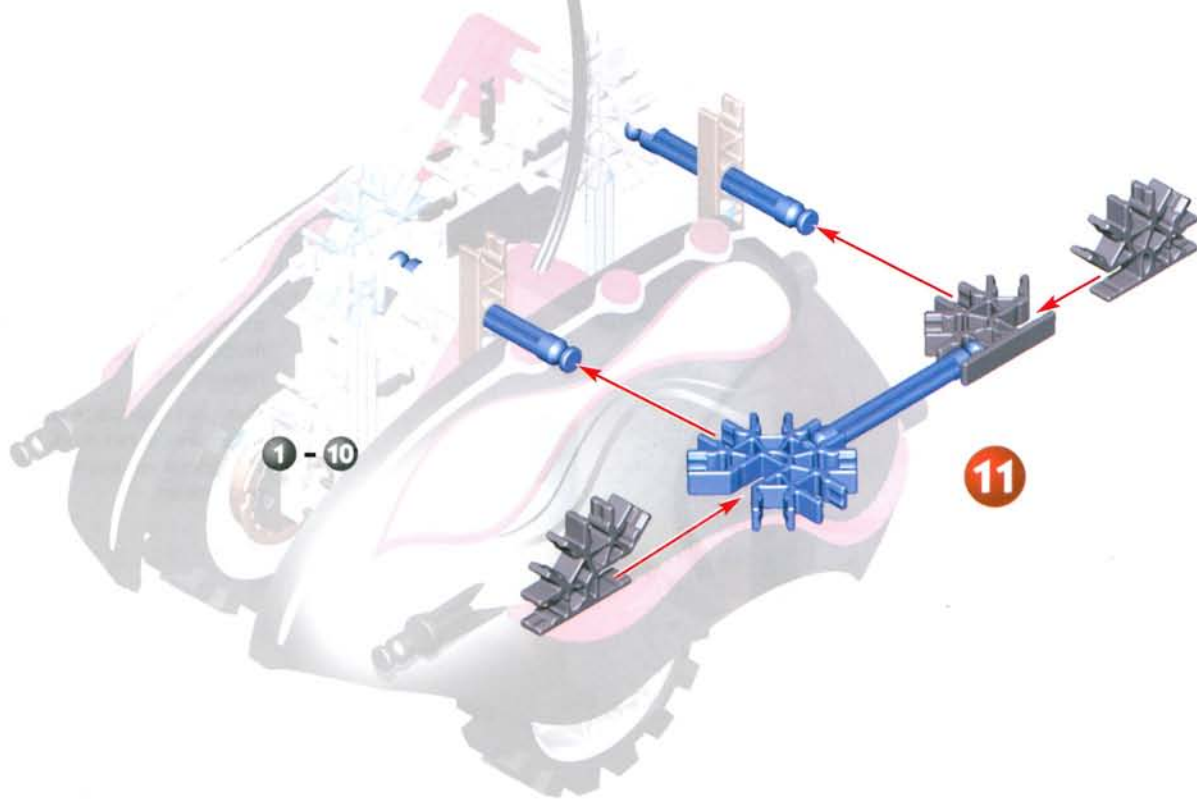

1 - 10

11

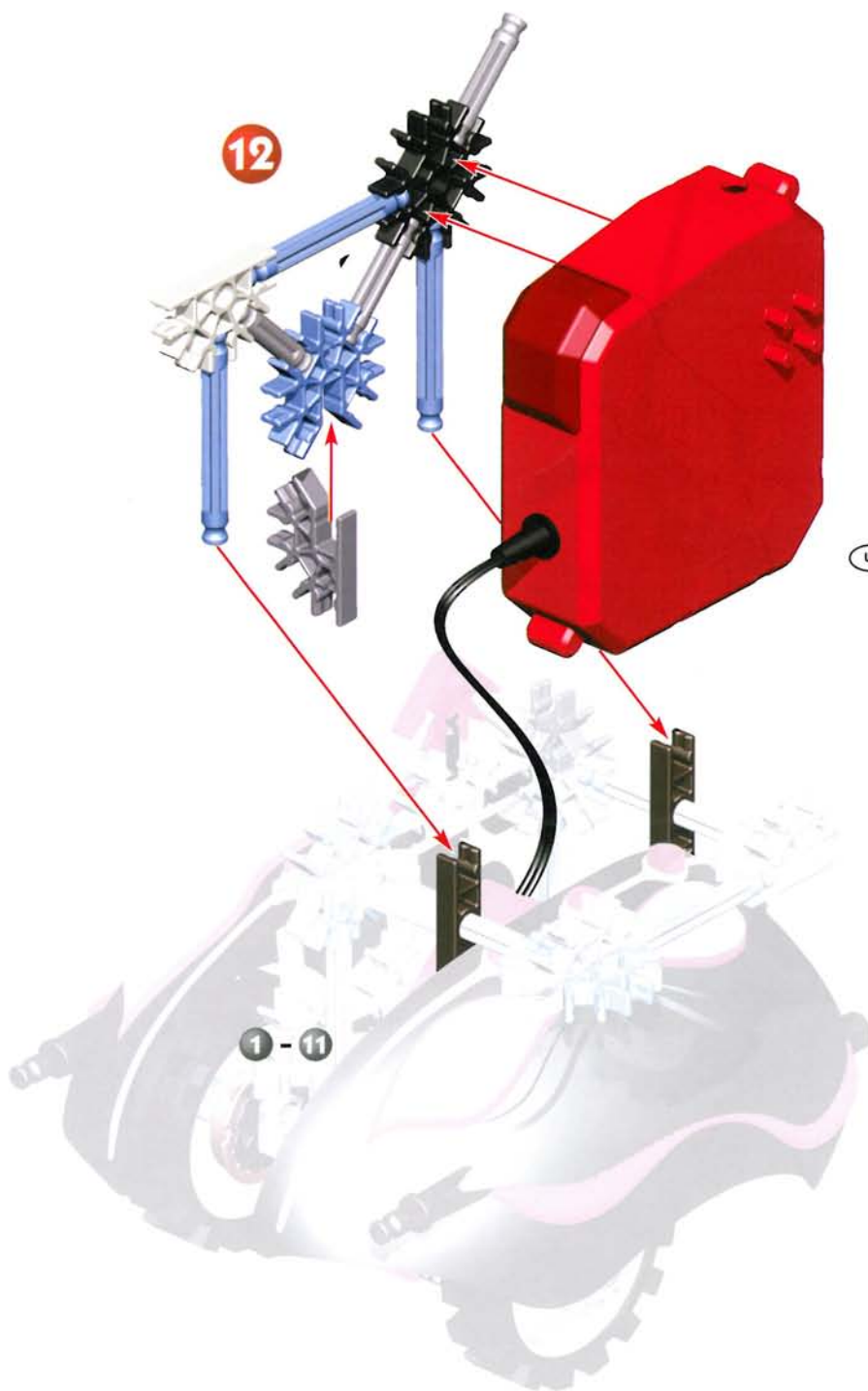

- (US) (GB) Tuck excess cord into model, away from all moving parts.  
 (F) Cachez le cordon excédentaire soigneusement à l'intérieur du modèle, à l'écart des pièces en mouvement.  
 (NL) Steek het overtollige snoer netjes weg in het model, veilig verwijderd van bewegende onderdelen.

- 2 
- 2 
- 3 
- 2 
- 2 
- 1 

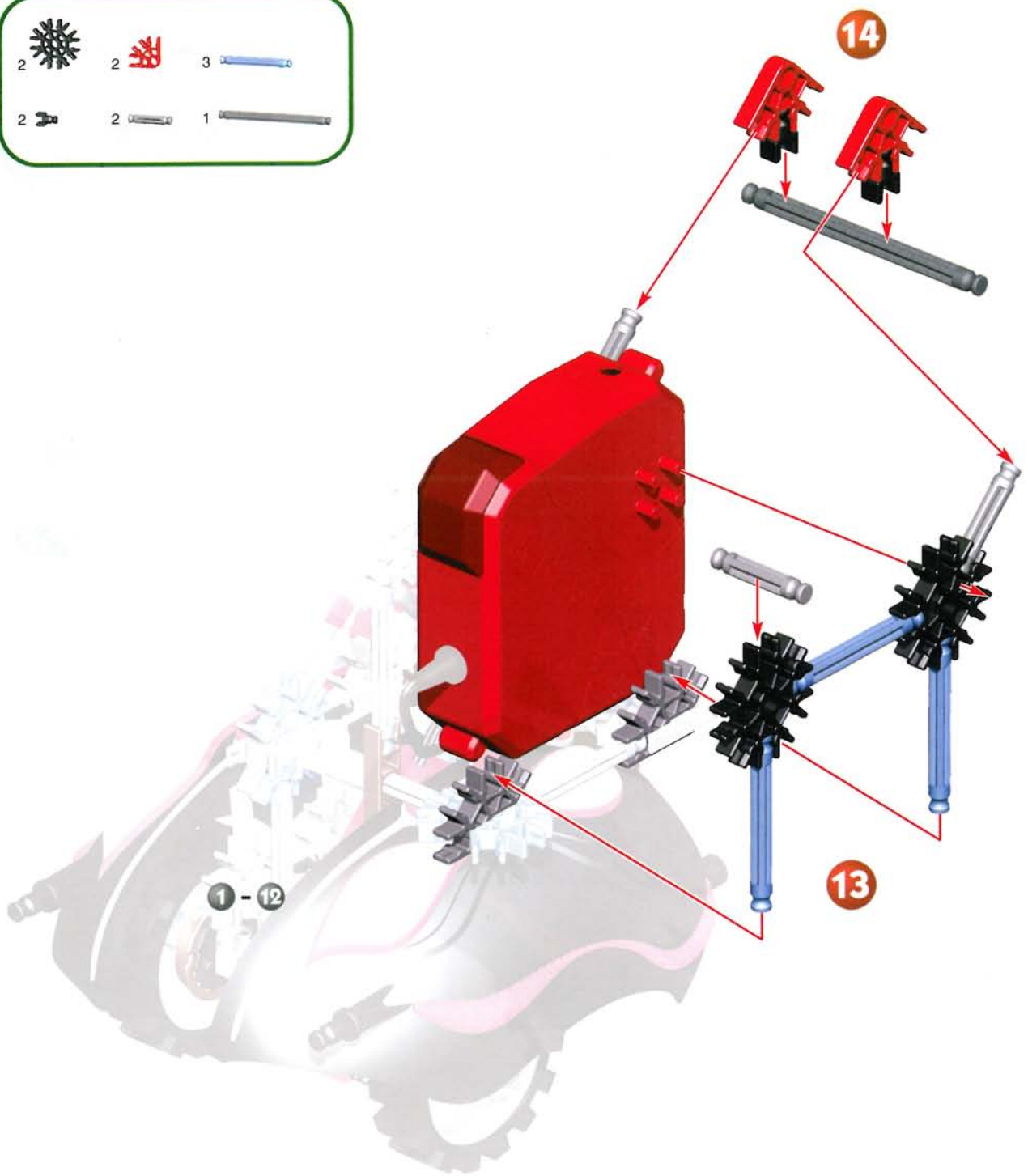

14

13

1 - 12

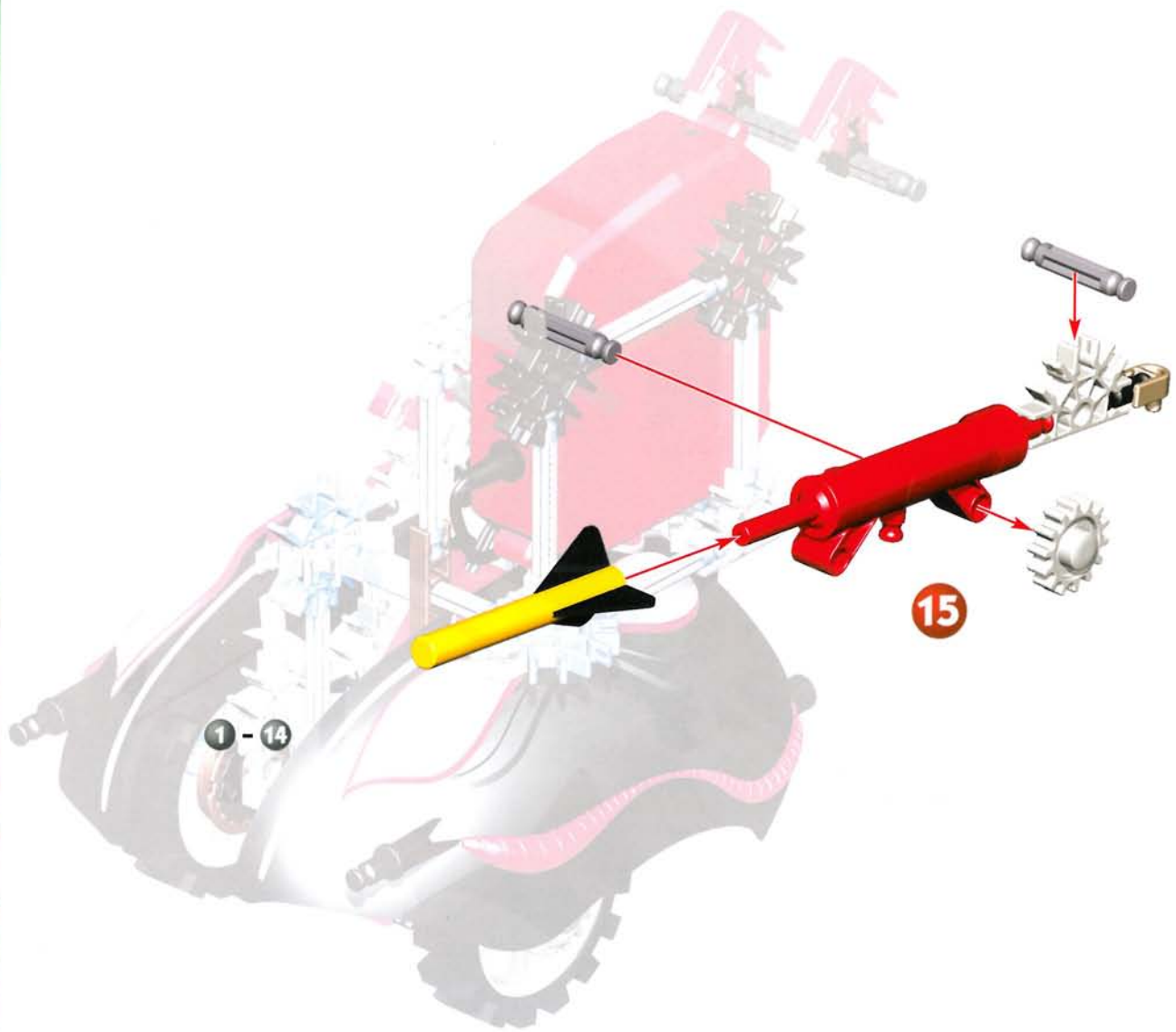
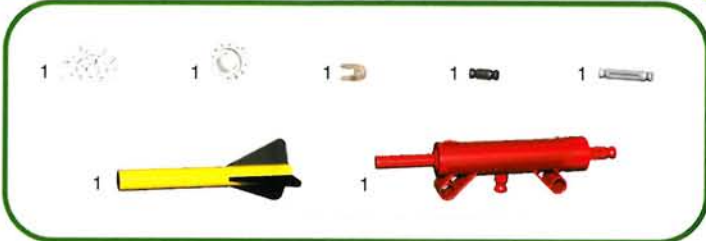

- |   |   |   |   |   |   |
|---|---|---|---|---|---|
| 3 |  | 1 |  | 2 |  |
| 1 |  | 2 |  | 4 |  |
| 1 |  | 1 |  |   |   |





- |   |  |   |   |   |   |   |   |
|---|--|---|---|---|---|---|---|
| 1 |  | 3 |  | 2 |  | 1 |  |
| 3 |  | 1 |  | 3 |  | 1 |  |
| 1 |   | 1 |  |   |   |   |   |

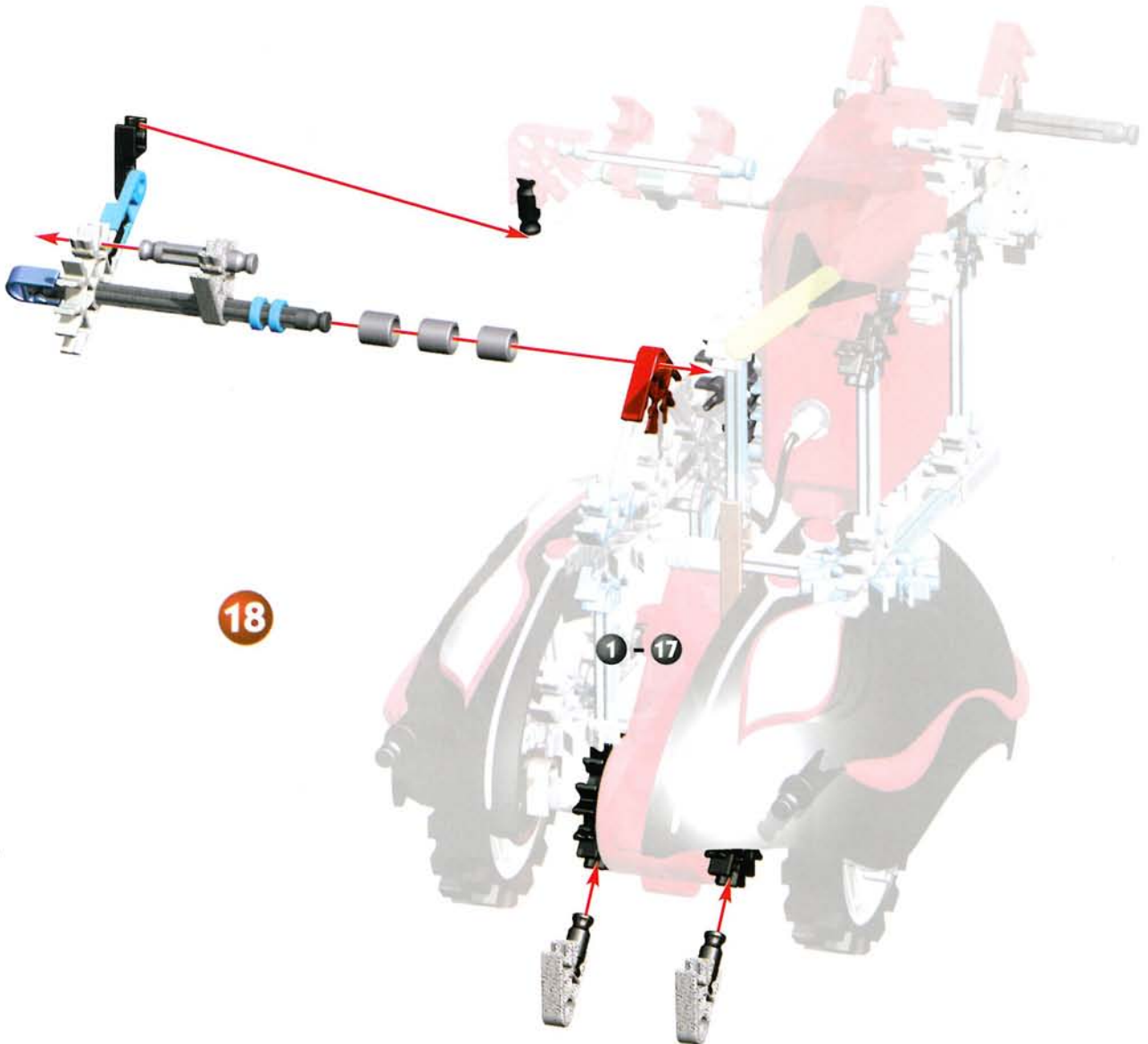

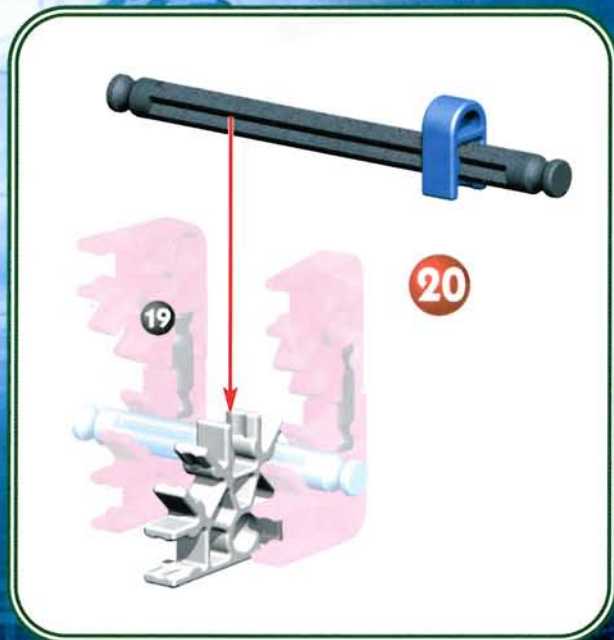
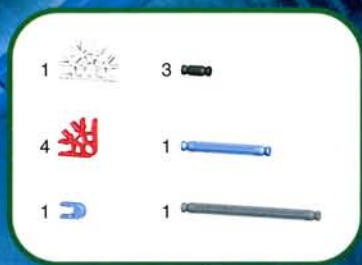
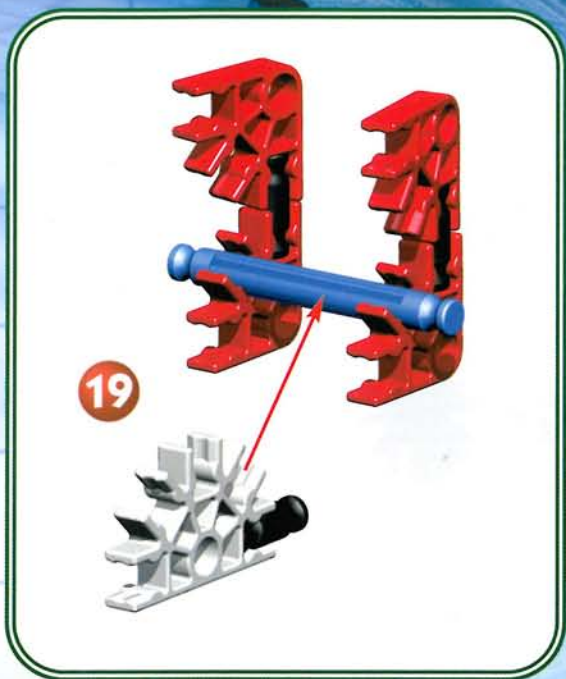

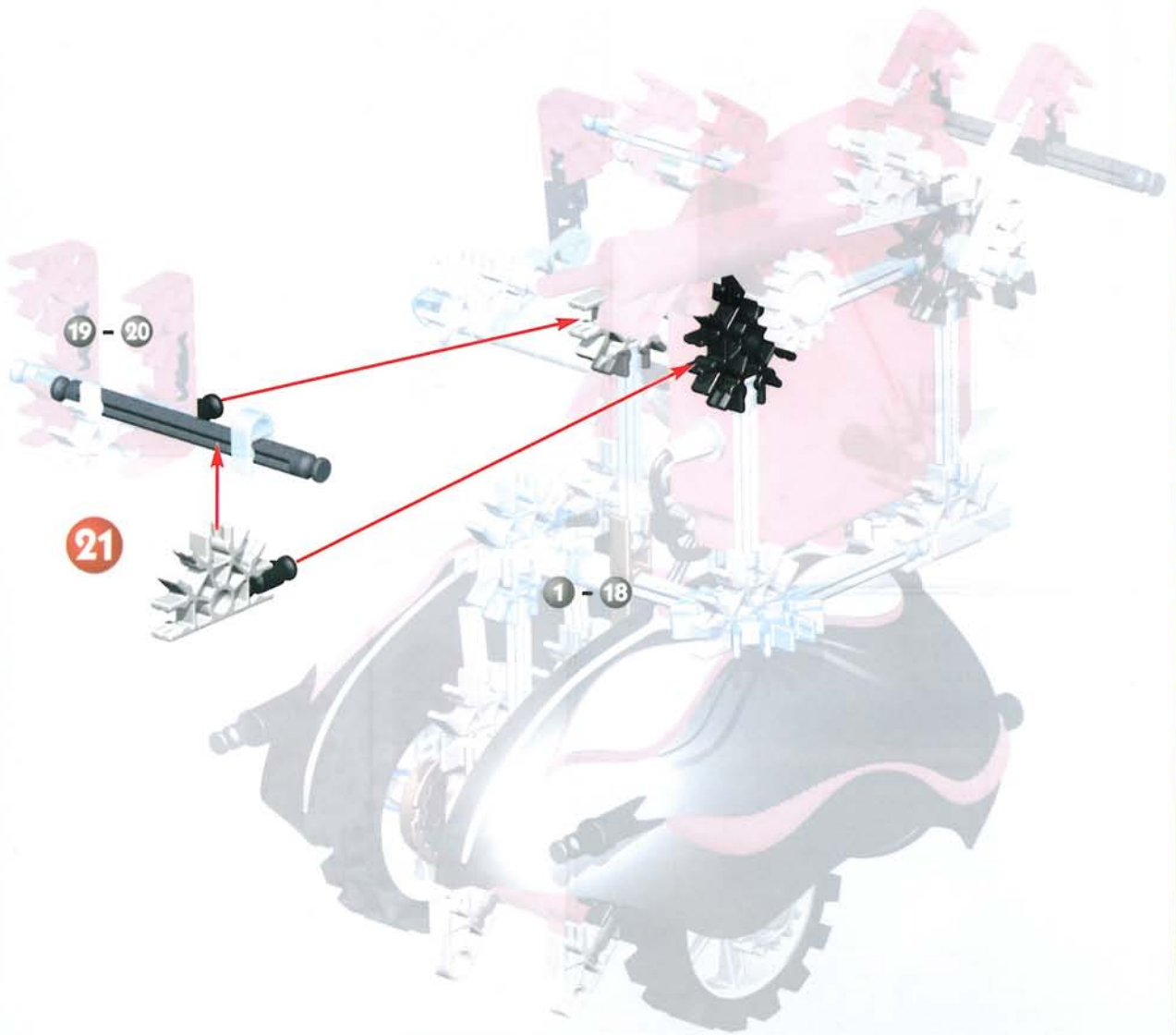



1



1



1



2

22



1 - 21

3 

5 

3 





- (US) (GB) Back view
- (F) Vue arrière
- (NL) Zicht van achter





**US** **GB** To set the Missile Launcher, hook the tip of the bronze Connector over the gray Rod as shown.

**F** Pour armer le lanceur de missiles, accroche le bout du connecteur bronze sur la tige grise comme indiqué.

**NL** Om de lanceerinrichting van de raket in te stellen, haak de punt van de bronzen koppelaar over de grijze stang zoals afgebeeld.







©2003 K'NEX Industries, Inc. P.O. Box 700 Hatfield, PA 19440-0700



**US 1-800-KID-KNEX US/Canada only (English only)**

**GB 00800-22427276 UK/Ireland only**

**F E D NL 001-215-996-4823**



**US Consumer Services  
K'NEX Industries, Inc.  
P.O. Box 700  
Hatfield, PA 19440-0700**



**GB K'NEX  
Newport Consumer Services  
Hasbro UK Ltd., Caswell Way  
Newport, Gwent NP9 0YH**



**www.knex.com**



**email@knex.com**



**WARNING:**

**CHOKING HAZARD-** Small parts.  
Not for children under 3 years.



**AVERTISSEMENT:**

**DANGER D'ÉTOUFFEMENT-** Pièces de petite  
taille Ne pas donner aux enfants de moins de 3 ans.



**WAARSCHUWING:**

**VERSTIKKINGSGEVAAR-** In verband met kleine  
onderdelen niet geschikt voor kinderen tot 3 jaar.

Printed in China  
Imprimerie aux China

Product and colors may vary. Models can be built one at a time. K'NEX is a registered trademark of K'NEX Industries, Inc.  
Le produit et les couleurs peuvent varier. La plupart des modèles peuvent être construits un à la fois. K'NEX est une marque  
déposée de K'NEX Industries, Inc.

Manufactured under U.S. Patents/Fabriqué sous brevets américains 5,061,219; 5,137,486; 5,199,919; 6,460,572.  
Other U.S. and foreign patents pending. Autres brevets américains et étrangers en instance.

Visit the website for the complete ReKconstructors story, online Comics and Game!  
Visite le site web pour l'intégralité du récit des ReKconstructors, des bandes dessinées en ligne et un jeu!

**www.REKONSTRUCTORS.com**



403424.11