

10805/62708

REKONSTRUCTORS™

BUILD TO BATTLE, REBUILD TO SURVIVE!

CONSTRUIRE POUR COMBATTRE, RECONSTRUIRE POUR SURVIVRE!

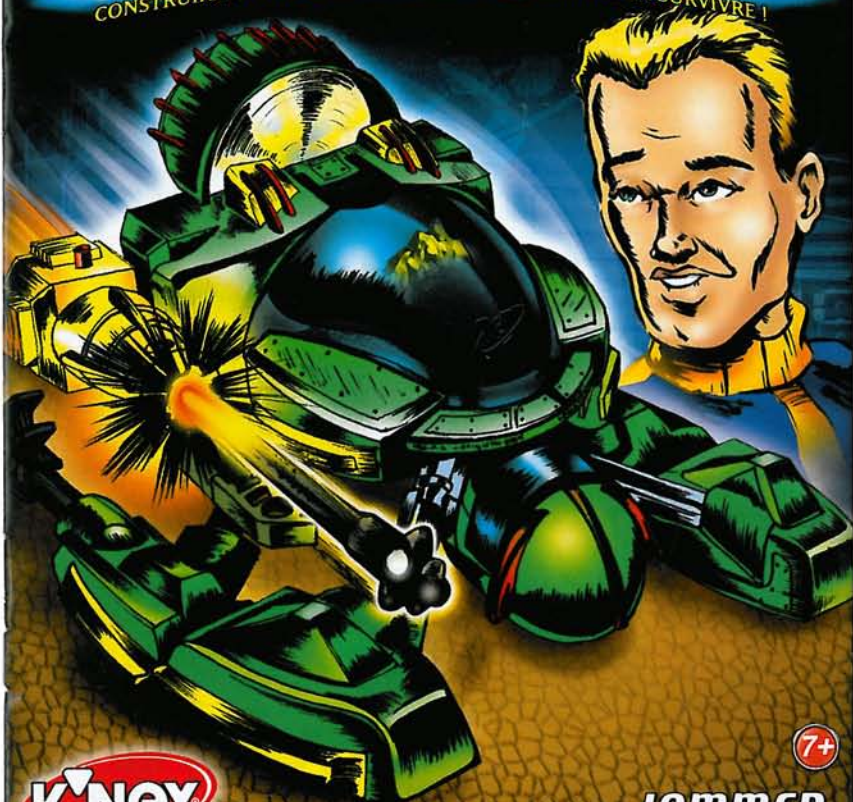

K'NEX

Building System Système De Construction

JAMMER™

7+



JAMMER™

Zack Armstrong was chosen for the XTractor Team because of his techno-savvy. While orbiting ZeKor, the XTractors receive a garbled message from the Elite Pilots describing an incredible source of power before the transmission is cut short. Passing through ZeKor's atmosphere, the XTractors are fused with the equipment on board their ship. Upon regaining consciousness, Zack Armstrong realizes that he has merged with the ship's hovercraft – and attached to his body is a glowing PowerCore. Zack Armstrong becomes "Jammer."

Jammer's PowerCore enables him to confuse his enemies by "jamming" their brain waves. His mastery of computers and technology makes Jammer an essential part of the XTractors.

Zack Armstrong a été choisi par l' XTractor Team parce qu'il est un as de la technologie. Alors qu'ils sont en orbite sur ZeKor, les XTractors reçoivent des pilotes d'élite un message embrouillé décrivant une fabuleuse source de puissance avant l'interruption de la transmission. Traversant l'atmosphère de ZeKor, les XTractors fusionnent avec le matériel qui se trouve à bord de leur vaisseau. En reprenant connaissance, Zack Armstrong se rend compte qu'il a fusionné avec l'aéroglisser du vaisseau – et qu'un PowerCore incandescent est fixé à son corps. Zack Armstrong devient « Jammer. »

Jammer's PowerCore lui permet de faire perdre leurs moyens à ses ennemis en « brouillant » leurs ondes cérébrales. Sa maîtrise des ordinateurs et de la technologie font de Jammer un élément essentiel des XTractors.



AFTER CRASH LANDING, JAMMER TELLS THE OTHERS THAT HE HAS DETECTED 2 SIGNALS - A STRONG POWER FIELD AND A FAINT BLIP. AS JAMMER AND VEKTOR SET OFF FOR THE STRONG SIGNAL, BULLDOG HEADS FOR THE WEAKER ONE.

APRÈS UN ATERRISSAGE EN CATASTROPHE, JAMMER INDIQUE AUX AUTRES QU'IL A DISTINGUÉ 2 SIGNAUX : UN CHAMP DE PUISSANCE CLAIR ET UN SIGNAL TRÈS FAIBLE. JAMMER ET VEKTOR PARTANT À LA RECHERCHE DU SIGNAL CLAIR, BULLDOG SE DIRIGE VERS LE SIGNAL PLUS FAIBLE.





WHILE
ZOOMING
ACROSS THE
ZEKORIAN
SURFACE.

TRAVERSANT
EN TROMBE
LA SURFACE
DE ZEKORIAN.

JAMMER, YOU CAN CHECK THIS
OUT ALONE, RIGHT?

JAMMER, TU PEUX TE DÉBROUILLER
TOUT SEUL, NON ?

SURE, VEKTOR.
JUST BE CAREFUL.

BIEN SÛR, VEKTOR.
MAIS FAIS ATTENTION.

WITH VEKTOR GONE, JAMMER COMES ACROSS
THE SOURCE OF THE SIGNAL (A LARGE FIELD OF
BURIED POWERCORES AND A STONE FORMATION
COVERED IN FOSSIL-LIKE MARKINGS.)

VEKTOR PARTI, JAMMER TOMBE SUR L'ORIGINE
DU SIGNAL, UN GRAND CHAMP DE POWERCORES
À MOITIÉ ENTERRES ET UNE FORMATION ROCHEUSE
RECOUVERTE DE MARQUES RESSEMBLANT À DES FOSSILES.



WHAT THE ?!
C'EST PAS VRAI !



AS JAMMER INVESTIGATES,
HE IS ATTACKED BY TEMPEST.

ALORS QUE JAMMER ESSAIE DE
DÉCOUVRIR AUTRE CHOSE, IL
EST ATTAQUÉ PAR TEMPEST.

JAMMER'S POWERCORE SCRAMBLES TEMPEST'S THOUGHTS.
JAMMER'S POWERCORE BROUILLE LES PENSÉES DE TEMPEST.



WITH HIS THOUGHTS JAMMED,
TEMPEST CRASHES TO THE GROUND.

SES PENSÉES BROUILLÉES,
TEMPEST S'ÉCRASE AU SOL.

JAMMER ATTEMPTS TO ESCAPE.
JAMMER ESSAIE DE S'ENFUIR.



TO JAMMER'S SURPRISE,
TEMPEST LAUNCHES ONE
OF HIS POWERCORE
TORNADOS TO STOP HIM.

À LA GRANDE SURPRISE
DE JAMMER, TEMPEST
LANCE LUNE DE SES
TORNADOS POWERCORE
POUR L'ARRÊTER.

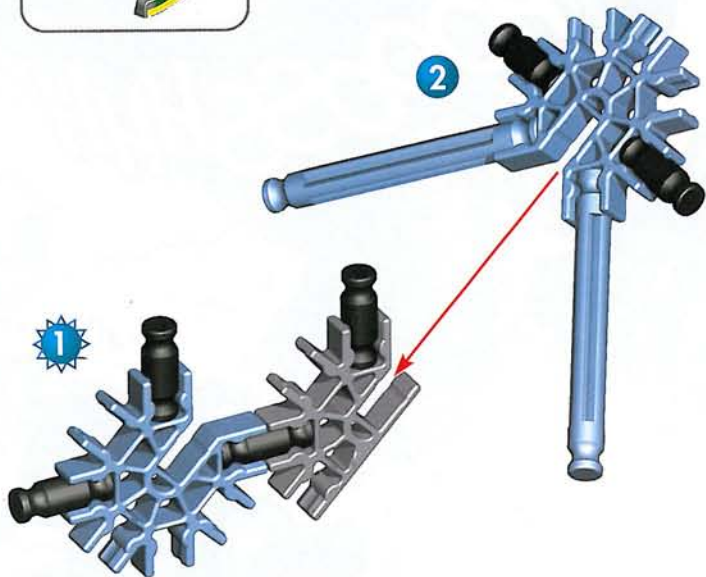

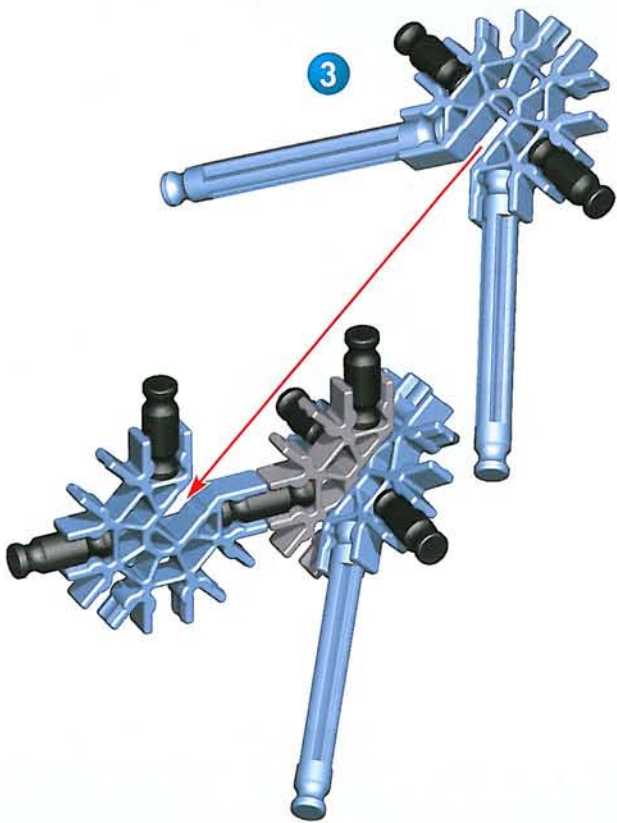

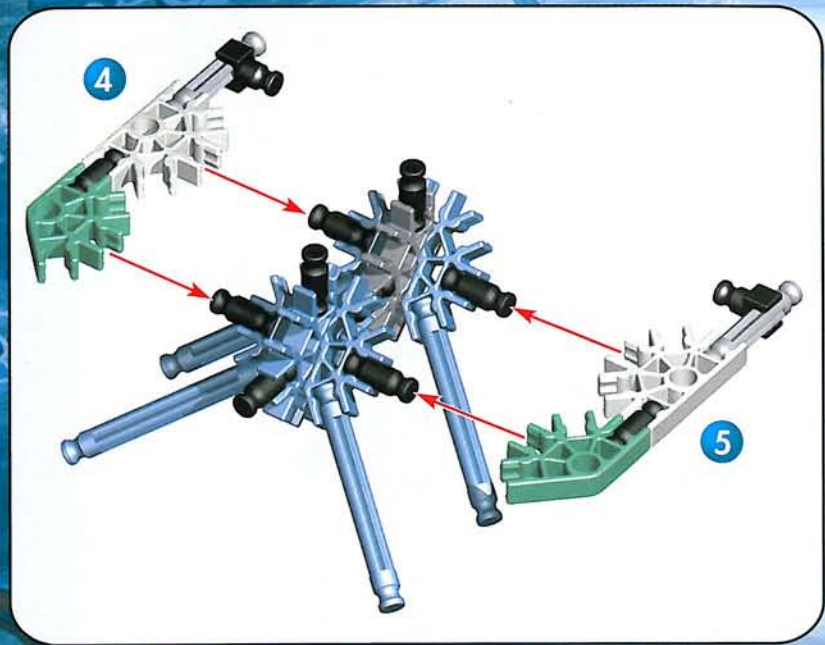

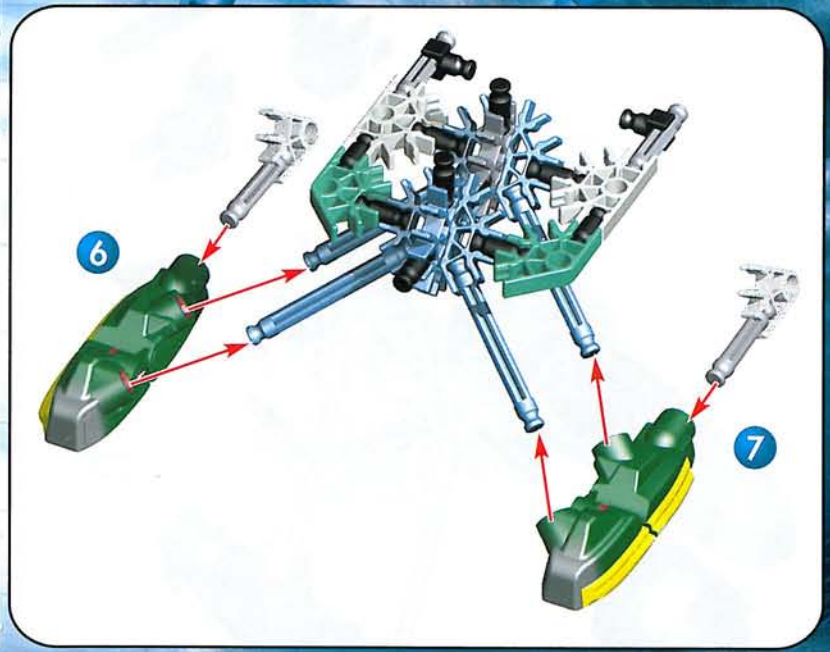

6

7

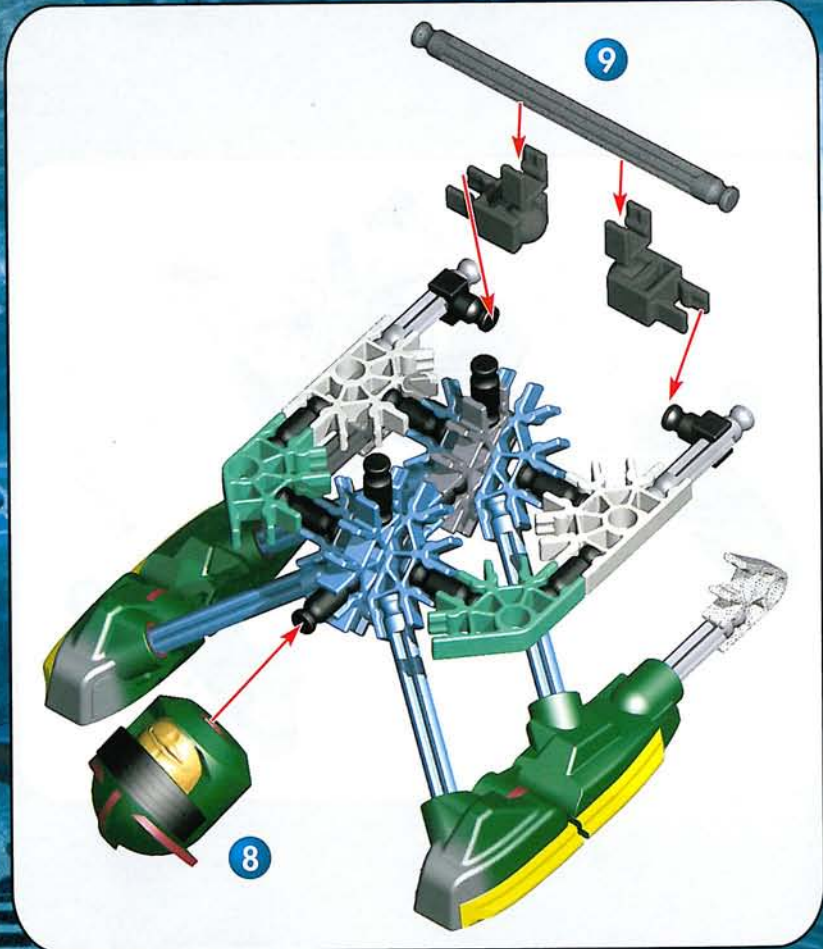

10



11

12

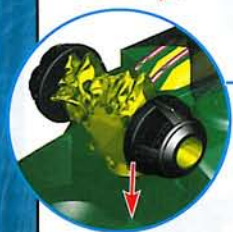



JAMMER IS TRAPPED BY
TEMPEST'S TORNADO.

JAMMER EST PIÉGÉ PAR
LA TORNADO DE TEMPEST.

JAMMER YELLS **"ReKconstruct!"** AND
CHANGES INTO BATTLE MODE.

JAMMER HURLE « REKONSTRUCT ! »
ET PASSE EN MODE DE COMBAT.



IN HIS NEW FORM, JAMMER TURNS TO FACE TEMPEST.
MÉTAMORPHOSÉ, JAMMER SE RETOURNE POUR
AFFRONTER TEMPEST.

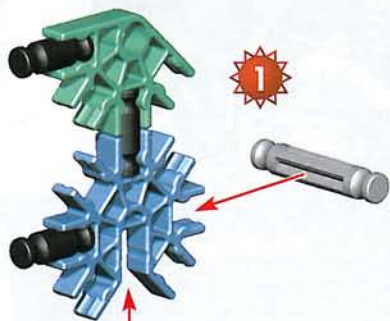

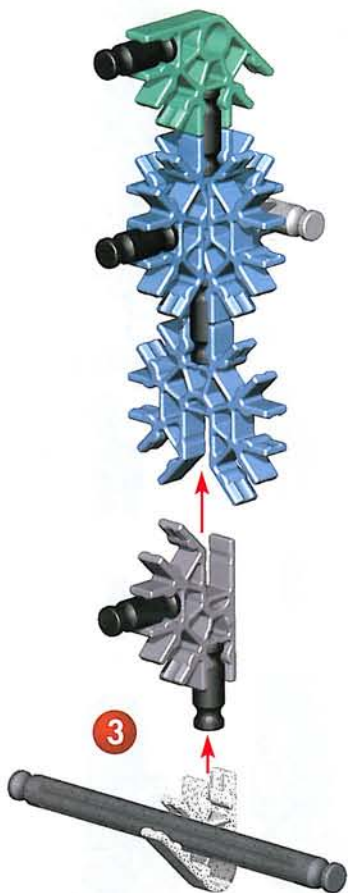

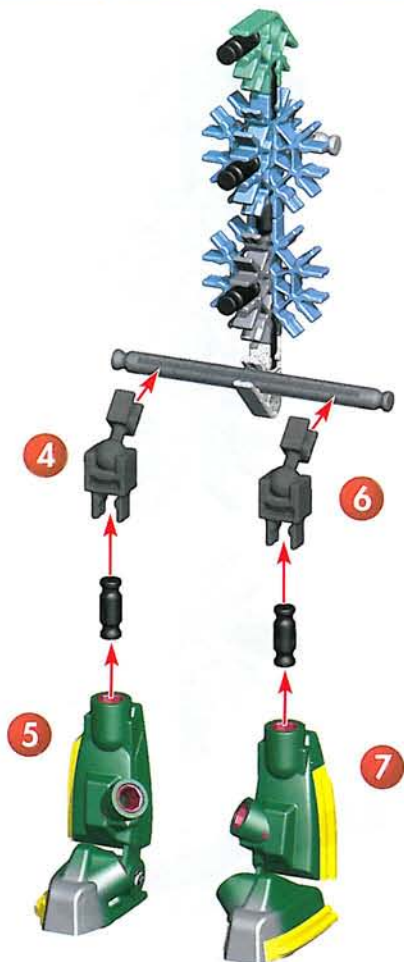

8

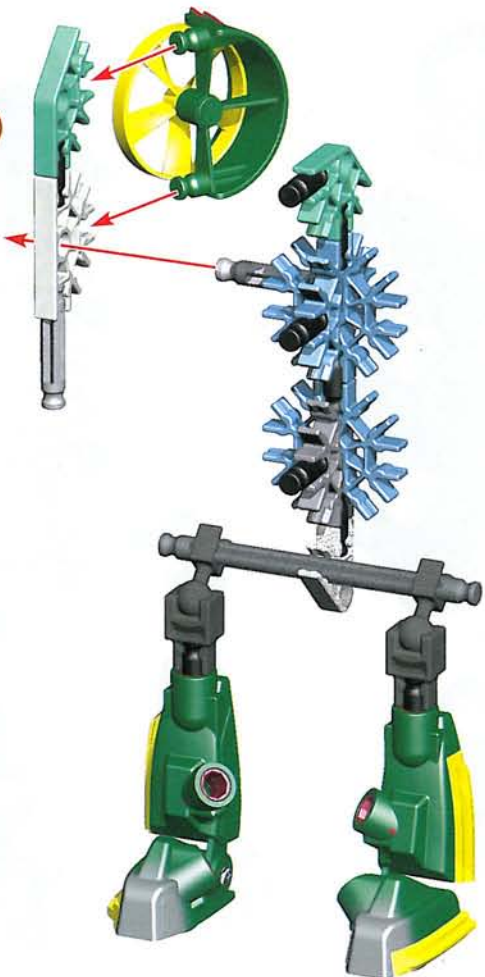

9



10

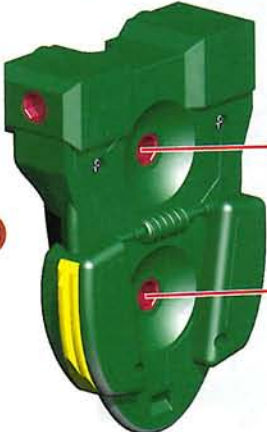

PowerCore™





11

12



13



14





JAMMER BLASTS TEMPEST, TRAPPING HIM UNDER ROCKS.

JAMMER FOUDDROIE TEMPEST, L'ENSEVELISSANT SOUS DES ROCHERS.



WITH TEMPEST TRAPPED, JAMMER VELS **"ReKconstruct!"**

TEMPEST COINCÉ, JAMMER HURLE « REKONSTRUCT ! »



JAMMER HEADS OFF TO FIND THE REST OF THE XTRACTORS.

JAMMER PART À LA RECHERCHE DES AUTRES XTRACTORS.

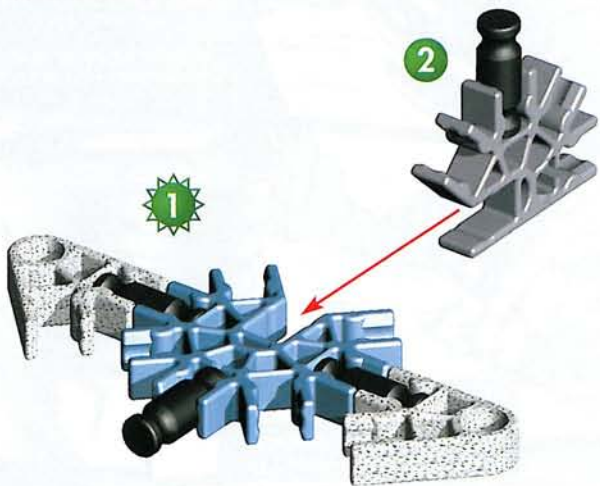

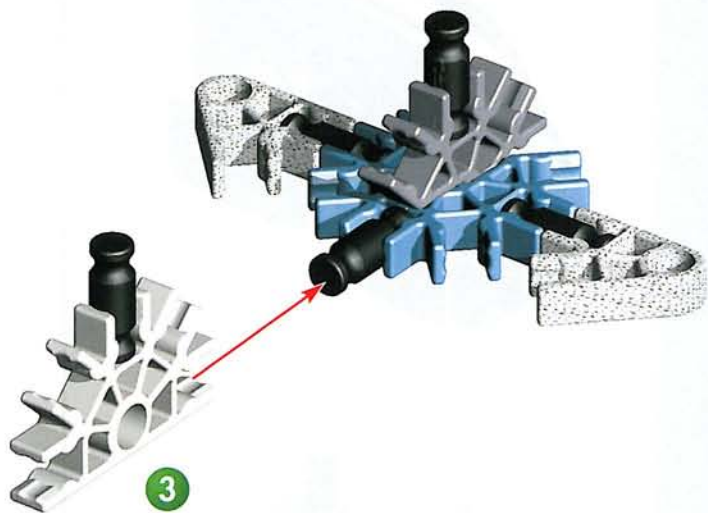

4

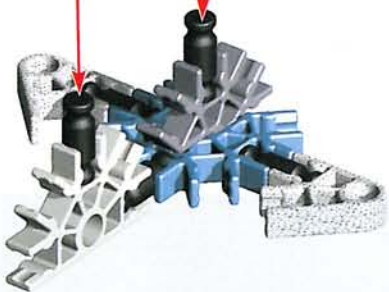
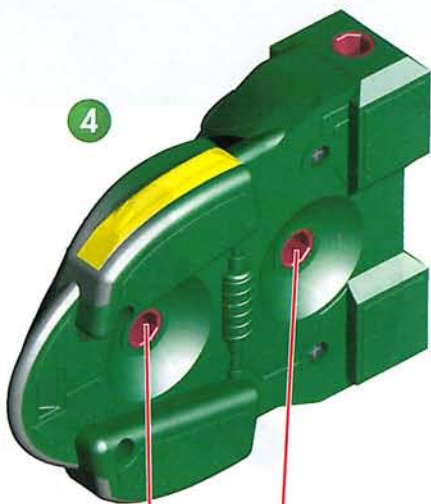

PowerCore™

5





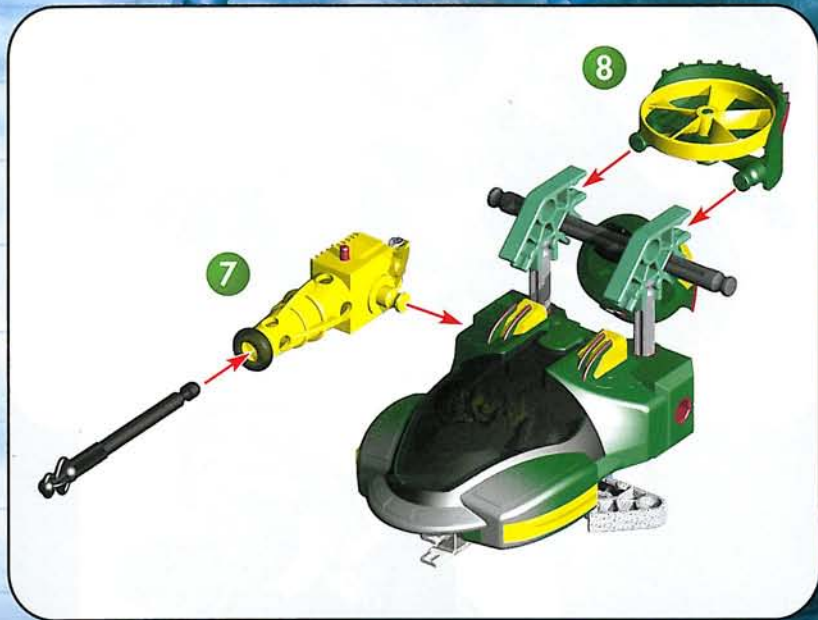



SPECIAL FEATURES *ATTRIBUTS SPÉCIAUX*

SPINNING
TURBO FAN
VENTILATEUR
TURBO TOURBILLONNANT

NEUROJAM POWERCORE
POWERCORE NEUROCOINCE

PRESS BUTTON
TO FIRE MISSILES
*APPUYE SUR LE
BOUTON POUR
PROPULSER
LES MISSILES*

INSERT MISSILE TO RELOAD
*INTRODUIS UN MISSILE
POUR RECHARGER*

Caution: Do not launch in the direction of people, animals, or walls; you could cause injury or damage.
Never attempt to launch any projectiles other than K'NEX missiles.

Mise en garde : ne pas lancer en direction de personnes, d'animaux, ou de murs pour éviter le risque de blesser quelqu'un ou de provoquer des dégâts. Ne jamais tenter de lancer d'autres projectiles que les missiles K'NEX.

Opgelet: Niet lanceren in de richting van mensen, dieren of muren; je zou letsel of schade kunnen veroorzaken. Nooit proberen om andere projectielen dan K'NEX raketten te lanceren.



POWERCORE REGENERATING UNIT UNITÉ DE RÉGÉNÉRATION DU POWERCORE



You've captured the enemy's PowerCore (sold separately), and your own was depleted during the struggle. Now is the time to regenerate them both for use in your next battle. Place both PowerCores in the PCRU, recharge, and be prepared for the next fight!

Tu as capturé le PowerCore de l'ennemi (vendu séparément), et le tien a été affaibli au cours de la bataille. Est maintenant l'heure de les régénérer tous les deux pour l'usage dans votre prochaine bataille. Placez les deux noyaux de puissance dans le PCRU, recharge, et soyez préparé pour le prochain combat !

PARTS COUNT NOMBRE DE PIÈCES



www.REKONSTRUCTORS.com

Enter all 3 XTractor codes for complete, online Mega-Build instructions.

Entre les codes de tous les 3 XTractor pour obtenir en ligne des instructions complètes de Mega-Build.

DYNAMIX



VEKTOR: ----

BULLDOG: ----

JAMMER: 10805

Enter *THEIR* World - Get the Story, Play the Game!
Entre dans *LEUR* monde - Connais l'histoire, Joue le jeu !



Collect 'em All! Collectionne-les tous!

Elite Pilots™



DIESEL™



SHADOW™



RYDER™



Zekorian Creatures™



RAVAGE™



RAZOR™



TEMPEST™

XTractors™



SKYHAWK™



BULLDOG™



VEKTOR™



JAMMER™



RELIC™





©2003 K'NEX Industries, Inc. P.O. Box 700 Hatfield, PA 19440-0700



US 1-800-KID-KNEX US/Canada only (English only)

GB 00800-22427276 UK/Ireland only

F E D NL 001-215-996-4823



US Consumer Services
K'NEX Industries, Inc.
P.O. Box 700
Hatfield, PA 19440-0700



GB K'NEX
Newport Consumer Services
Hasbro UK Ltd., Caswell Way
Newport, Gwent NP9 0YH



www.knex.com



email@knex.com



WARNING:

CHOKING HAZARD- Small parts.
Not for children under 3 years.



AVERTISSEMENT:

DANGER D'ÉTOUFFEMENT- Pièces de petite
taille Ne pas donner aux enfants de moins de 3 ans.



WAARSCHUWING:

VERSTIKKINGSGEVAAR- In verband met kleine
onderdelen niet geschikt voor kinderen tot 3 jaar.

Printed in China
Imprimerie aux China

Product and colors may vary. Models can be built one at a time. K'NEX is a registered trademark of K'NEX Industries, Inc.
Le produit et les couleurs peuvent varier. La plupart des modèles peuvent être construits un à la fois.
K'NEX est une marque déposée de K'NEX Industries, Inc.

Manufactured under U.S. Patents/Fabriqué sous brevets américains 5,061,219; 5,137,486; 5,199,919; 6,460,572.
Other U.S. and foreign patents pending. Autres brevets américains et étrangers en instance.

Conforms to the Requirements of ASTM Standard Consumer Safety Specification on Toy Safety, F963-96a.
Conforme aux spécifications de sécurité du consommateur sur la sécurité des jouets
de la norme ASTM F963-96a.

Visit the website for the complete ReKconstructors story, online Comics and Game!

Visite le site web pour l'intégralité du récit des ReKconstructors, des bandes dessinées en ligne et un jeu!

www.REKONSTRUCTORS.com



404012.11-U1-8/03