

12044/62729

REKONSTRUCTORS™

BUILD TO BATTLE, REBUILD TO SURVIVE!
CONSTRUIRE POUR COMBATTRE, RECONSTRUIRE POUR SURVIVRE!

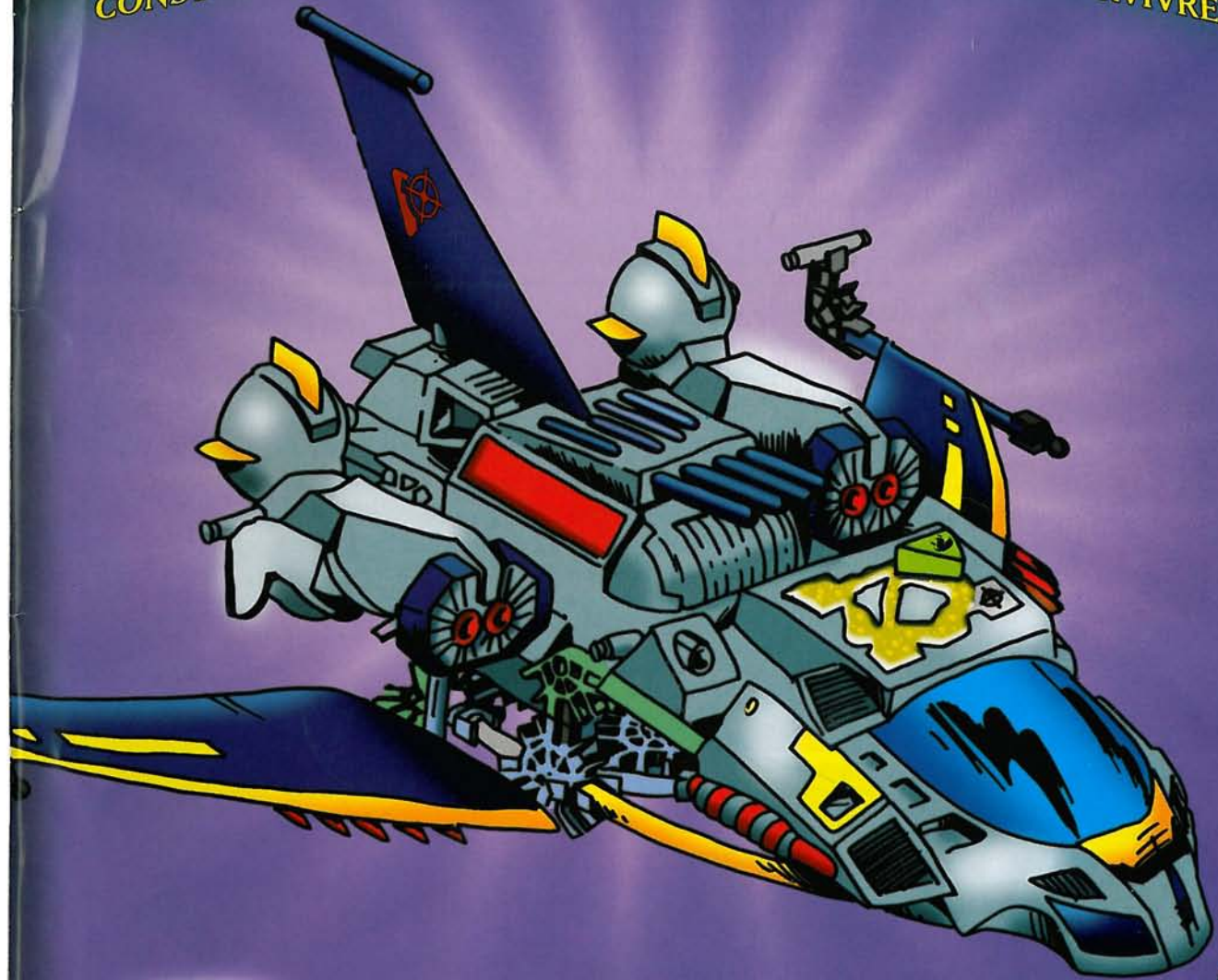

Building System
Système De Construction

8+

ReKonstructors StrikeForce™

INFERNOSTRIKE™



INFERNOSTRIKE™

The StrikeForce is sent to ZeKor for one purpose – to secure the planet's surface against the reawakened ZeKorian Fossils. The extreme danger can only be faced by the highly armed StrikeForce soldiers, who have intentionally fused with the equipment on their ship to become fighting machines! With PowerCores pumping plasma, they can reconstruct into 3 different modes, making the StrikeForce a formidable team!

On Earth, Marine Corps Reconnaissance Leader Flint Michaels' career remains highly classified. Now, as commander of the ReKonstruktors StrikeForce, Col. Michaels is InfernoStrike! InfernoStrike's Pyrotech PowerCore gives him the ability to control fire. Add his flying skills and firing missiles, and InfernoStrike is an unmatched fighter!

La StrikeForce est envoyée à ZeKor pour une seule raison – sécuriser la surface de la planète contre les Fossiles ZeKorian qui sont sortis de leur sommeil. Le danger extrême qu'ils représentent ne peut être affronté que par les soldats de la StrikeForce qui sont armés jusqu'aux dents et qui ont été fusionnés, à dessein, avec le matériel de leur vaisseau afin de devenir des machines à combattre ! Avec des PowerCores pompant du plasma, ils peuvent se reconstituer en trois modes différents, faisant de la StrikeForce une redoutable équipe !

Sur la planète Terre, les missions du chef de reconnaissance de la Marine Flint Michaels demeurent hautement confidentielles. Désormais, en tant que commandant de la StrikeForce des ReKonstruktors, le colonel Michaels est InfernoStrike ! Le PowerCore d'InfernoStrike, la Pyrotech, lui donne l'aptitude de contrôler le feu. Avec ses dons de pilote, et ses missiles, InfernoStrike est un combattant sans égal !



SABRIX, THE LARGEST AND MOST FIERCE OF THE NEWLY REVIVED ZEKORIANS, SLOWLY RISES OUT OF THE RECENTLY FORMED BLAST CRATER. NEARBY, THE XTRACTOR VEKTOR IS UNAWARE OF THE CREATURE'S APPROACH.

SABRIX, LE PLUS IMPOSANT ET LE PLUS FÉROCE DES ZEKORIANS QUI VIENNENT D'ÊTRE RESSUSCITÉS, ÉMERGE LENTEMENT DU CRATÈRE RÉCEMMENT FORMÉ PAR LA FRAPPE. À PROXIMITÉ, L'XTRACTOR VEKTOR NE REMARQUE PAS L'APPROCHE DE LA CRÉATURE.





I THINK THAT'S THE XTRACTOR JASON MICHAELS, I MEAN VEKTOR, AND HE'S IN TROUBLE!
JE CROIS QU'IL S'AGIT DE L'XTRACTOR JASON MICHAELS, JE VEUX DIRE VEKTOR, ET IL EST DANS UNE SITUATION DÉLICATE !

INFERNOSTRIKE, CRUISING OVERHEAD, NOTICES THAT VEKTOR IS NOW TRAPPED BY SABRIX.

INFERNOSTRIKE, SURVOLANT LES LIEUX, REMARQUE QUE VEKTOR EST MAINTENANT PIÉGÉ PAR SABRIX.

AHHHHHHHHH!

KKKRRRRRAAKKK!

SABRIX CLAMPS HIS POWERFUL JAWS DOWN ON VEKTOR. SABRIX SAISIT VEKTOR ENTRE SES MÂCHOIRES PUISSANTES.



INFERNOSTRIKE LAUNCHES A MISSILE ATTACK AT SABRIX, CAUSING HIM TO DROP VEKTOR. INFERNOSTRIKE LANCE UNE ATTAQUE DE MISSILES EN DIRECTION DE SABRIX, LUI FAISANT AINSI LÂCHER VEKTOR.



AS VEKTOR TRIES TO ESCAPE, SABRIX USES HIS PERMAFROST POWERCORE TO FREEZE VEKTOR.

ALORS QUE VEKTOR TENDE DE S'ENFUIR, SABRIX USE DE SON PERMAFROST POWERCORE POUR FIGER VEKTOR DANS LA GLACE.

AFTER TRAPPING VEKTOR, SABRIX TURNS HIS ATTENTION TO INFERNOSTRIKE.
VEKTOR UNE FOIS PRIS AU PIÈGE, SABRIX SE TOURNE VERS INFERNOSTRIKE.

FFFSSSHHHH!

BEFORE INFERNOSTRIKE
CAN REACT, SABRIX LAUNCHES
A MISSILE AT HIM.
AVANT QUE INFERNOSTRIKE
PUISSE RÉAGIR, SABRIX LANCE UN
MISSILE DANS SA DIRECTION.

GET OUT OF HERE
VEKTOR, I'LL HANDLE HIM!
SORIS DE LÀ VEKTOR, JE
M'OCCUPE DE LUI!

AS HE AVOIDS SABRIX'S MISSILE,
INFERNOSTRIKE USES HIS
PYROTECH POWERCORE TO
THAW OUT VEKTOR.

ÉVITANT LE MISSILE DE SABRIX,
INFERNOSTRIKE SE SERT DE
SON PYROTECH POWERCORE
POUR FAIRE FONDRE LA
GLACE QUI EMPRISONNE
VEKTOR.

AS VEKTOR ESCAPES,
INFERNOSTRIKE'S PLASMA
BEGINS PUMPING...

VEKTOR S'ÉCHAPPANT,
L'ADRENALINE DE
INFERNOSTRIKES'ACTIVE...



HE LANDS AND SHOUTS
"REKONSTRUCT!", CHANGING
INTO BATTLE MODE.

IL ATTERRIT ET HURLE
«REKONSTRUCT !», PASSANT
EN MODE DE COMBAT.

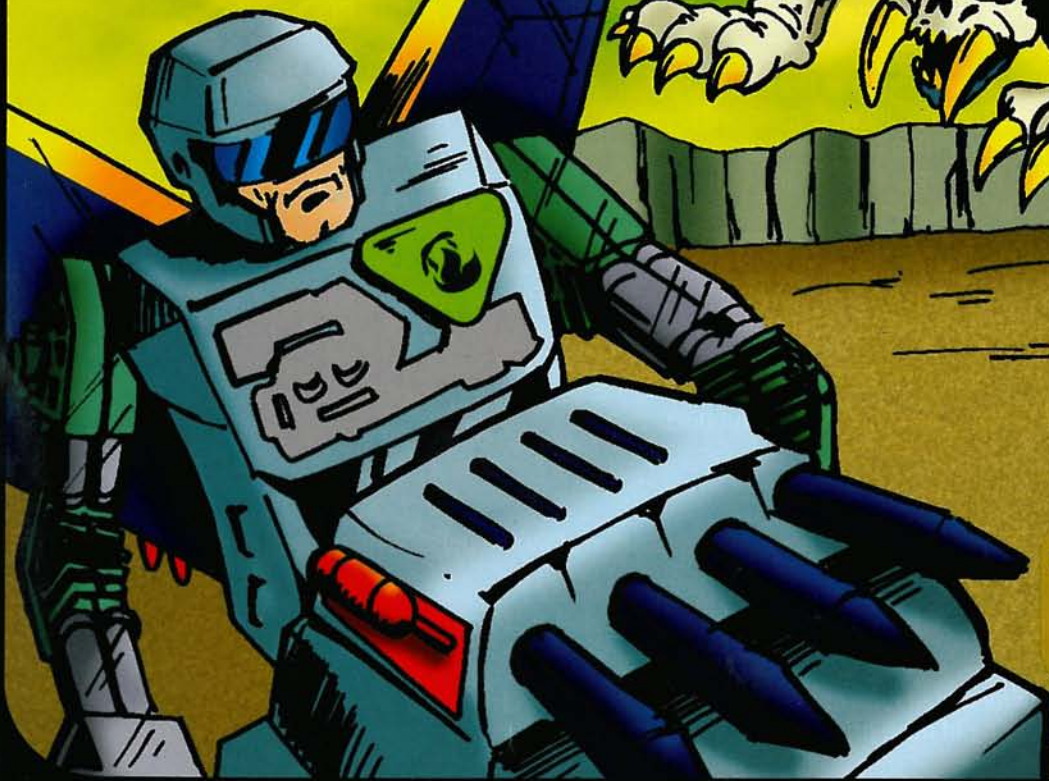

SABRIX LEAPS RIGHT AT
INFERNOSTRIKE, CATCHING
HIM OFF GUARD.

SABRIX BONDIT SUR
INFERNOSTRIKE, LE
PRENANT À DÉPOURVU.

US GB Read all instructions and warnings before you start to build and operate the models. Keep these instructions in a handy location. They contain important safety information.

F Lis tous les avertissements et les instructions avant de commencer le montage et l'exploitation du modèle. Garde ces instructions à portée de la main. Elles comportent d'importantes informations de sécurité.

NL Gelieve alle waarschuwingen en aanwijzingen te lezen vóór je het model begint op te bouwen en te gebruiken. Bewaar deze aanwijzingen op een gemakkelijk bereikbare plaats. Ze bevatten belangrijke veiligheidsgegevens.

US GB **WARNING:** As with all small items, these batteries should be kept away from children. If swallowed, seek medical attention immediately.

F **AVERTISSEMENT :** comme avec tous les petits objets, ces piles doivent être tenues hors de la portée des enfants. En cas d'ingestion, appeler immédiatement un médecin ou l'hôpital.

NL **WAARSCHUWING:** Zoals het geval is met alle kleine onderwerpen, moeten deze kleine batterijen verwijderd blijven van kinderen. Ingeval van inslikken, kijk onmiddellijk uit naar medische verzorging.

US GB **WARNING:** This is a Class 1 LED product.

US FCC Statements:

This device complies with Part 15 of the FCC rules. Operation is subject to the following two conditions:

1. This device may not cause harmful interference and
2. This device must accept any interference received including interference that may cause undesired operation.

This model is tested to comply with FCC standards - FOR HOME AND OFFICE USE.

FCC Statement:

This equipment has been tested and found to comply with the limits for a Class B digital device, pursuant to part 15 of the FCC rules. These limits were designed to provide reasonable protection against harmful interference in a residential installation. This equipment generates, uses, and can radiate radio frequency energy, and, if not installed and used in accordance with the instructions, may cause harmful interference to radio communications. However, there is no guarantee that interference will not occur in a particular installation. If this equipment does cause harmful interference to radio or television reception, which can be determined by turning the equipment off and on, the user is encouraged to try to correct the interference by one or more of the following measures: (1) Reorient or relocate the receiving antenna. (2) Increase the separation between the equipment and receiver. (3) Consult the dealer or an experienced radio/TV technician.

F **AVERTISSEMENT :** ce produit est un produit de Classe 1 LED.

NL **WAARSCHUWING:** dit is een klasse 1 LED-product.

US GB Caution:

Do not aim missiles at eyes or face. Never aim missiles at others or pets. Never attempt to launch any projectiles other than the K'NEX missiles.

F **MISE EN GARDE :** ne vise pas les yeux ou le visage avec les missiles. Ne vise jamais des personnes ou des animaux domestiques avec les missiles. Ne tente jamais de lancer des projectiles autres que les missiles K'NEX.

NL **OPGEPAST:** Geen missielen naar de ogen of het gezicht mikken. Nooit de missielen nooit naar anderen toe of naar geen dieren. Tracht nooit projectielen af te vuren die geen projectielen van K'NEX zijn.

US **GB** To replace batteries, remove the screw as shown. Insert 3 button cell (or LR44, A76 or SR44) batteries, matching the (+/-) diagram inside the compartment.

F Pour remettre les piles, retirer la vis comme l'indique le schéma. Installer 3 piles boutons LR44 (A76 ou SR44), en suivant le diagramme (+/-) gravé à l'intérieur du boîtier.

NL Verwijder de schroef zoals afgebeeld om de batterijen te vervangen. Steek er 3 LR44 (A76 of SR44) batterijen in, en doe ze overeenstemmen met het (+/-) diagram binnenin het compartiment.



US **GB** The light module comes with 3 button cell batteries already installed.

F Le module lumière vient avec 3 piles déjà installées.

NL De lichtmodule wordt met 3 reeds geïnstalleerde batterijen geleverd.

US **GB** Light is activated by pulling trigger.

F La lumière s'active en tirant sur la gâchette.

NL Het licht gaat aan wanneer aan de trekker getrokken wordt.

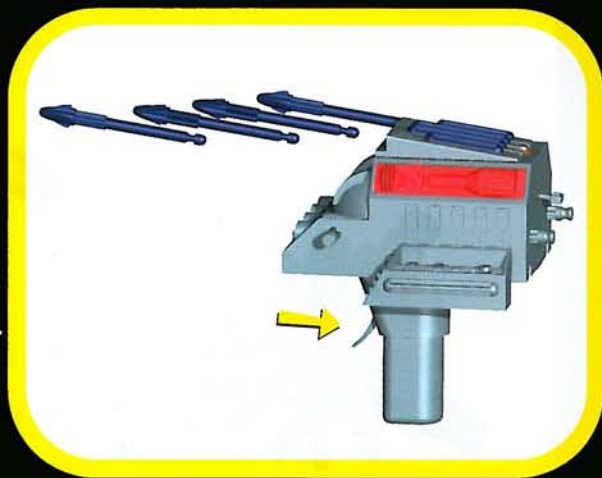

US **GB** Light doesn't work? Check to see if you have fresh button cell batteries and that they are installed properly.

F Le son et/ou la lumière ne marche pas ? Vérifie si les piles sont chargées et si elles sont bien installées.

NL Werkt het geluid en/of licht niet? Ga even na of de batterijen geladen zijn en of ze goed op hun plaats zitten.

Attack Mode

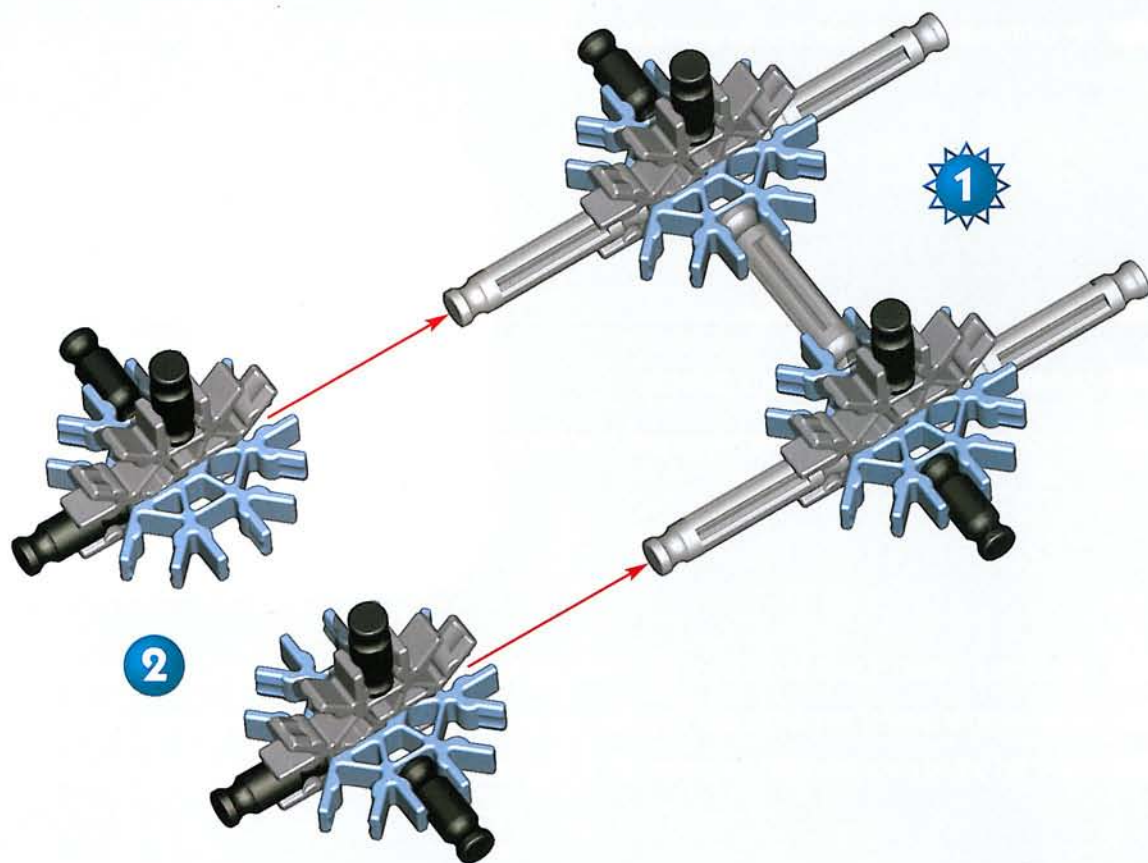

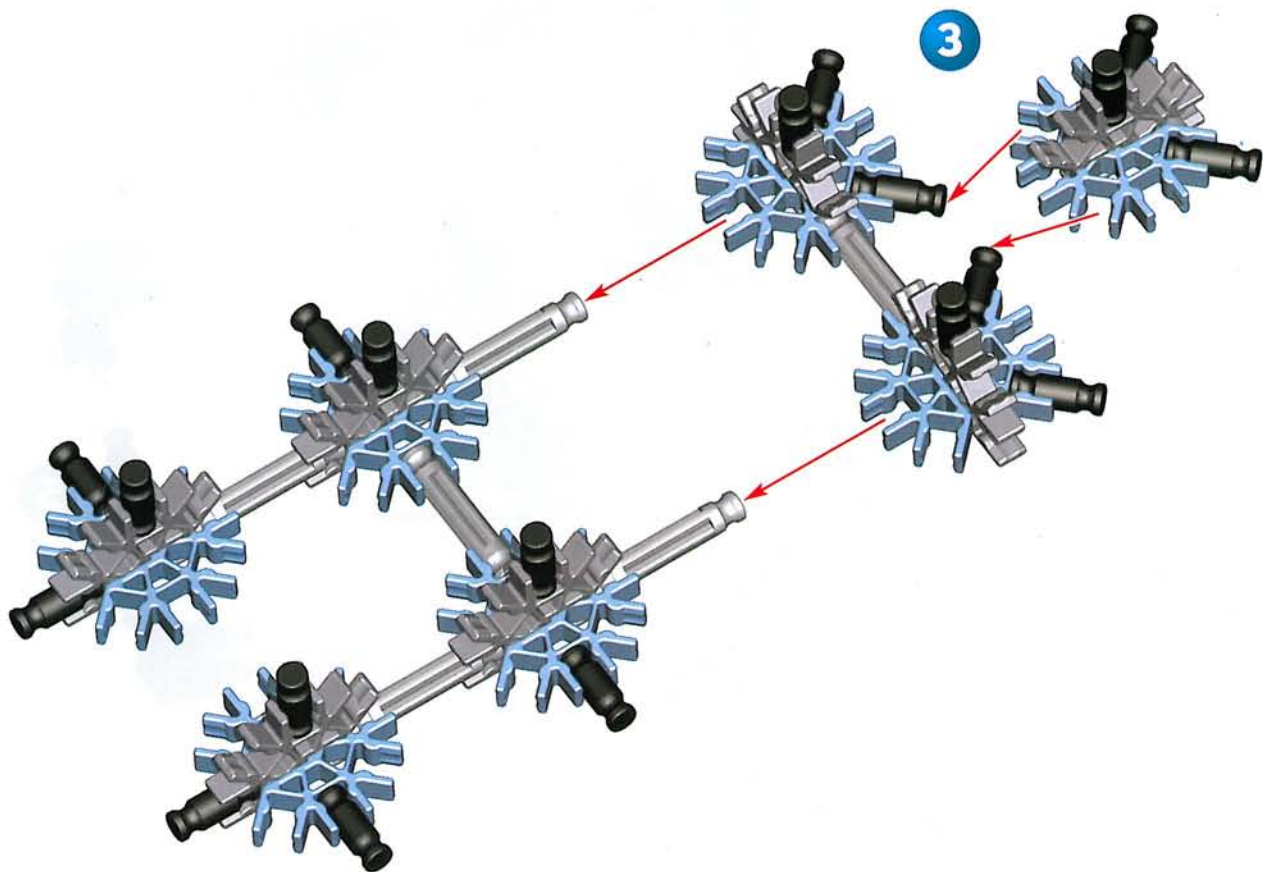

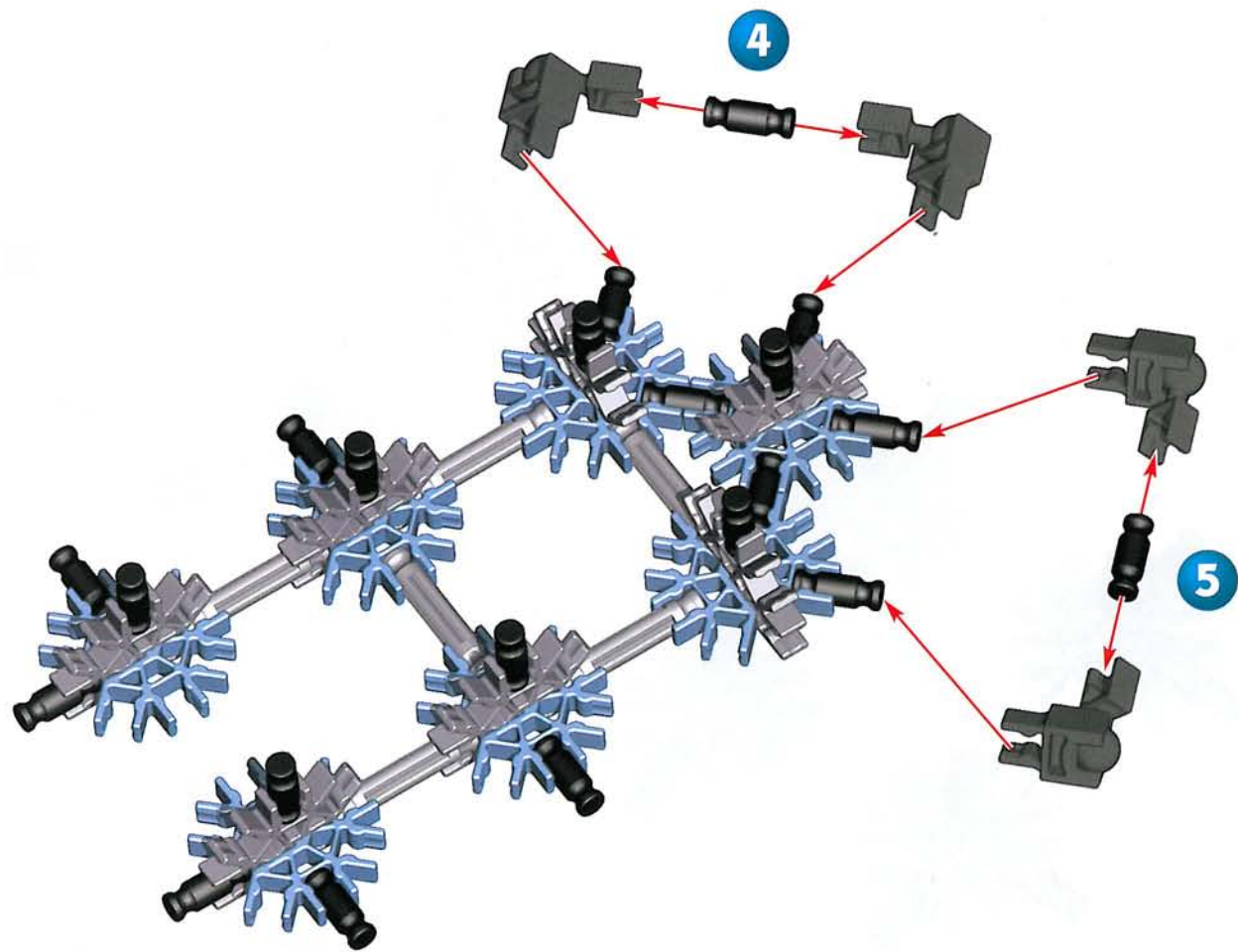

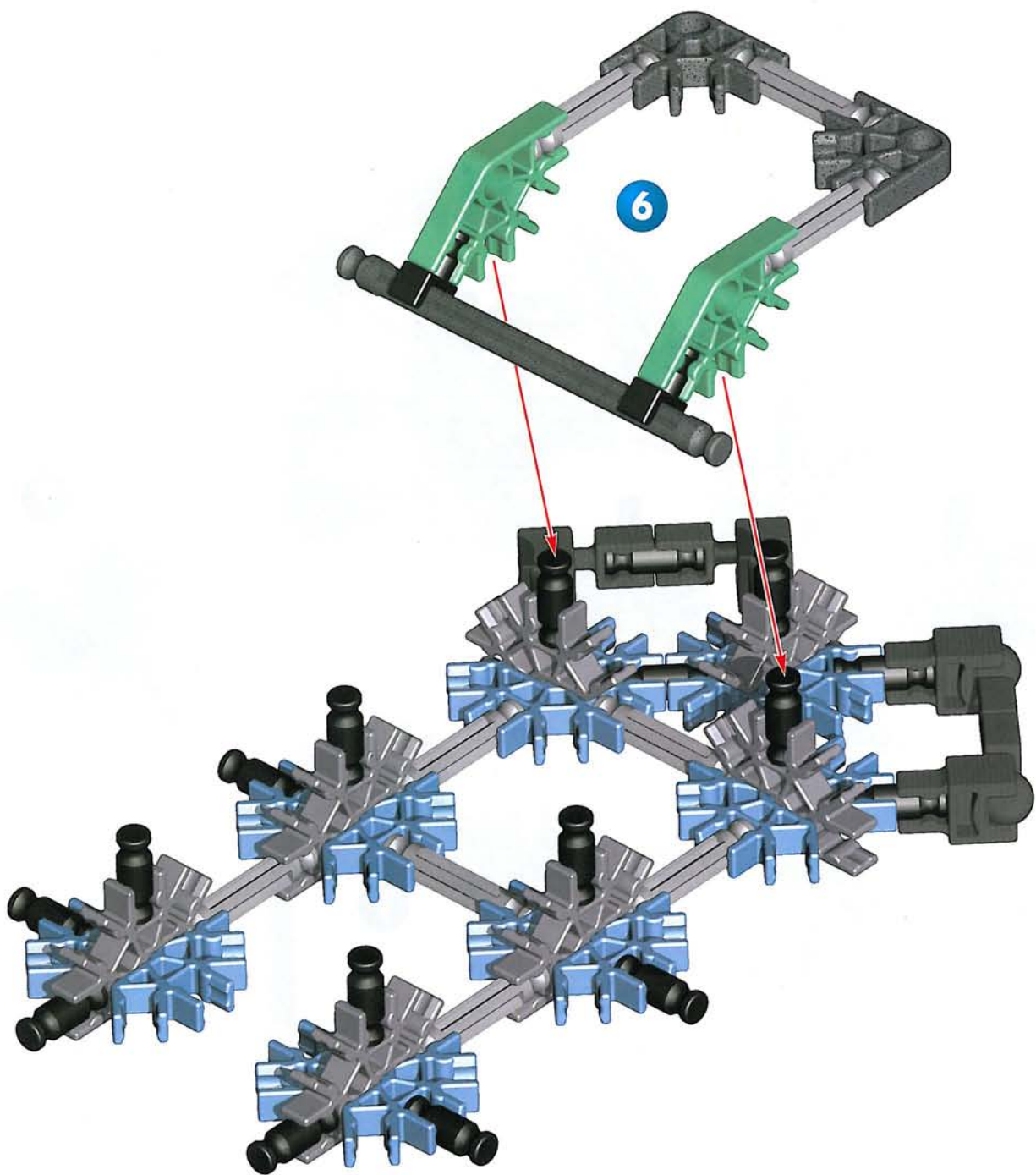

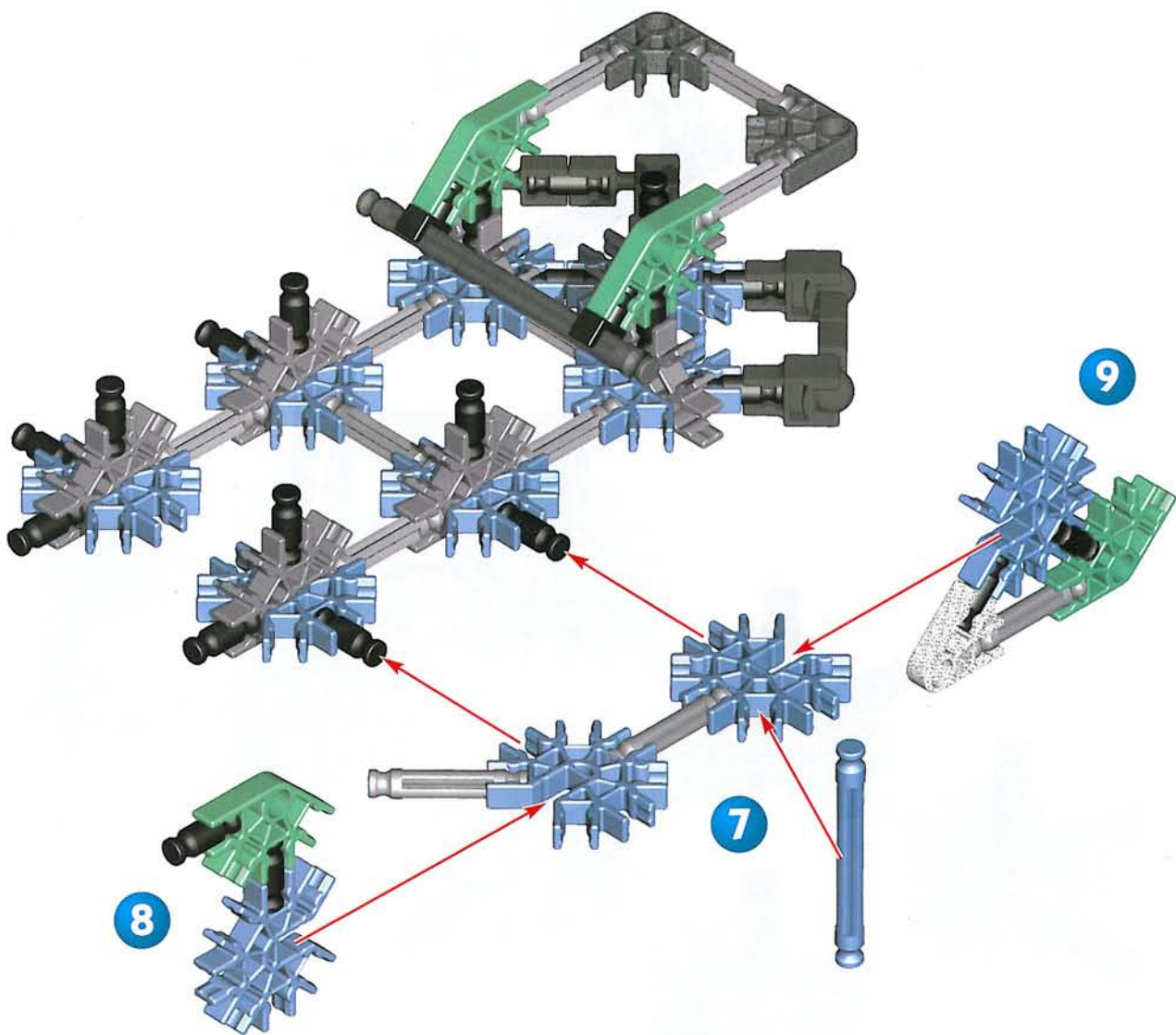

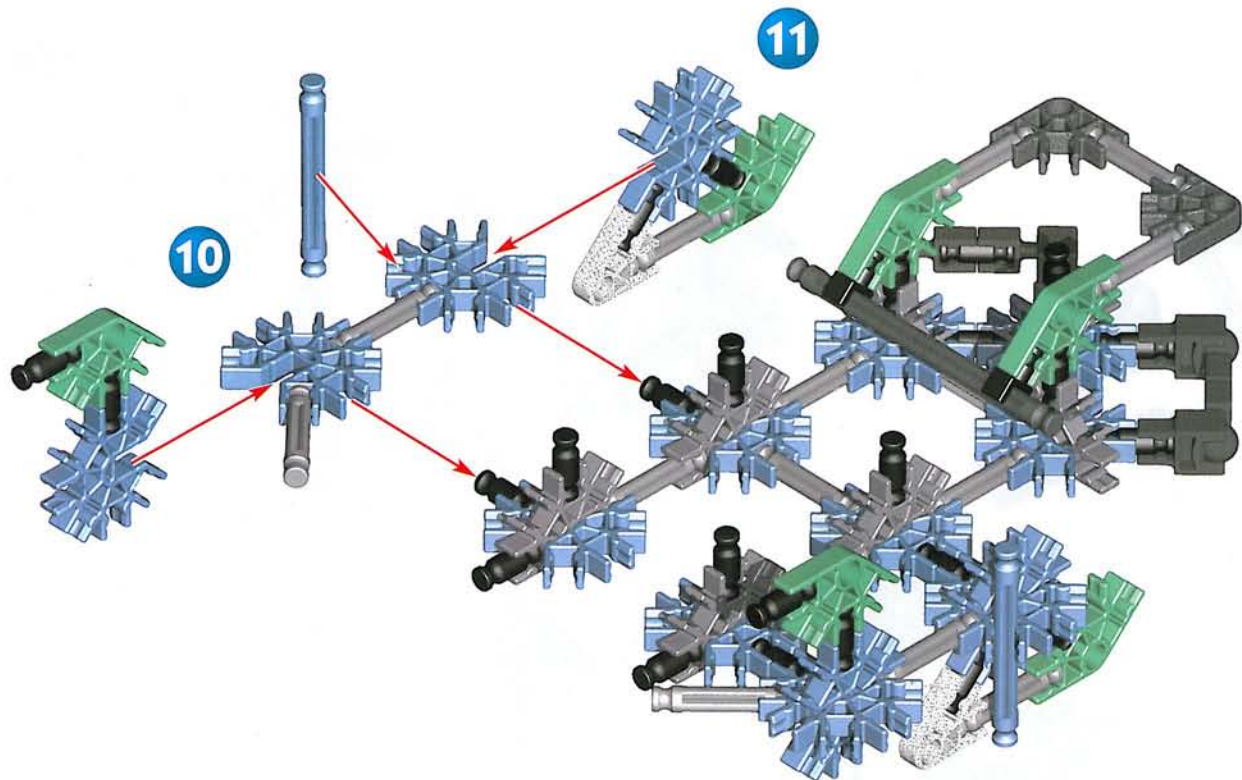

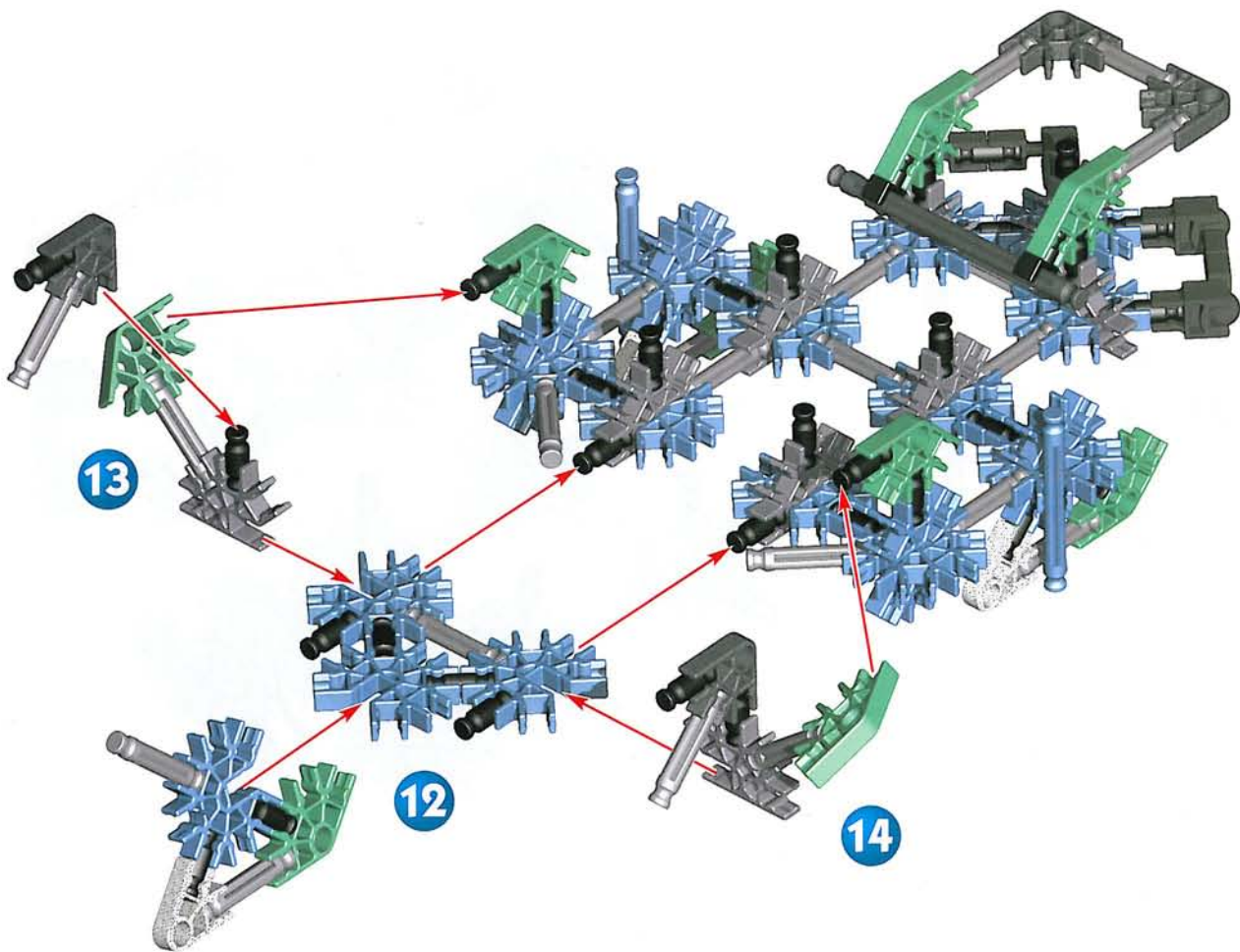

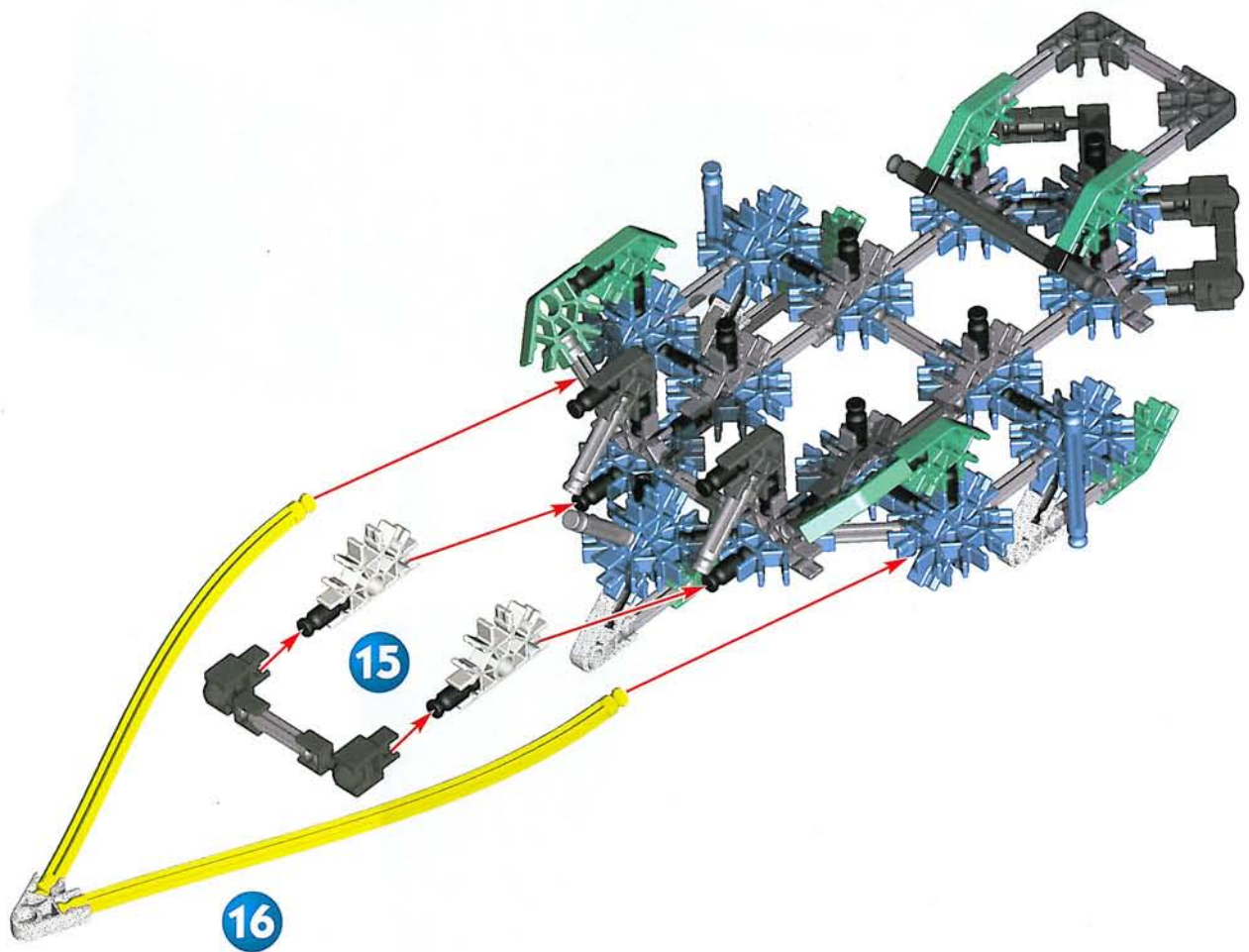

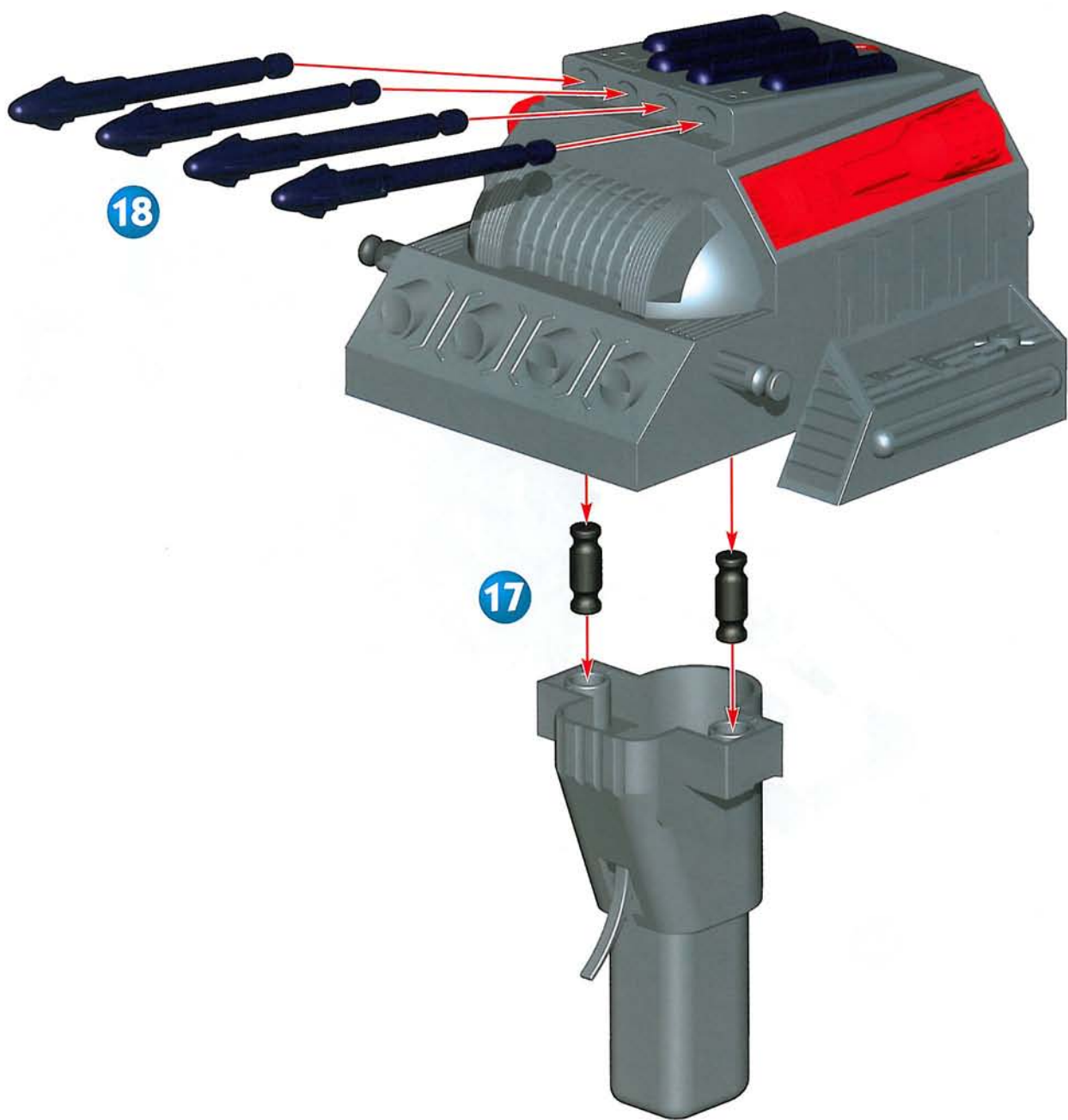

19

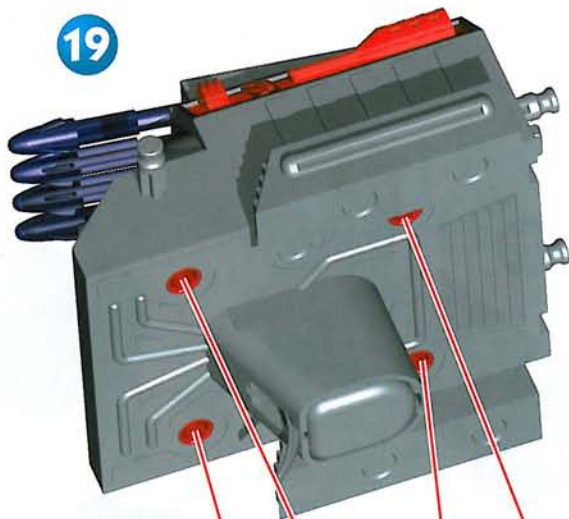

20

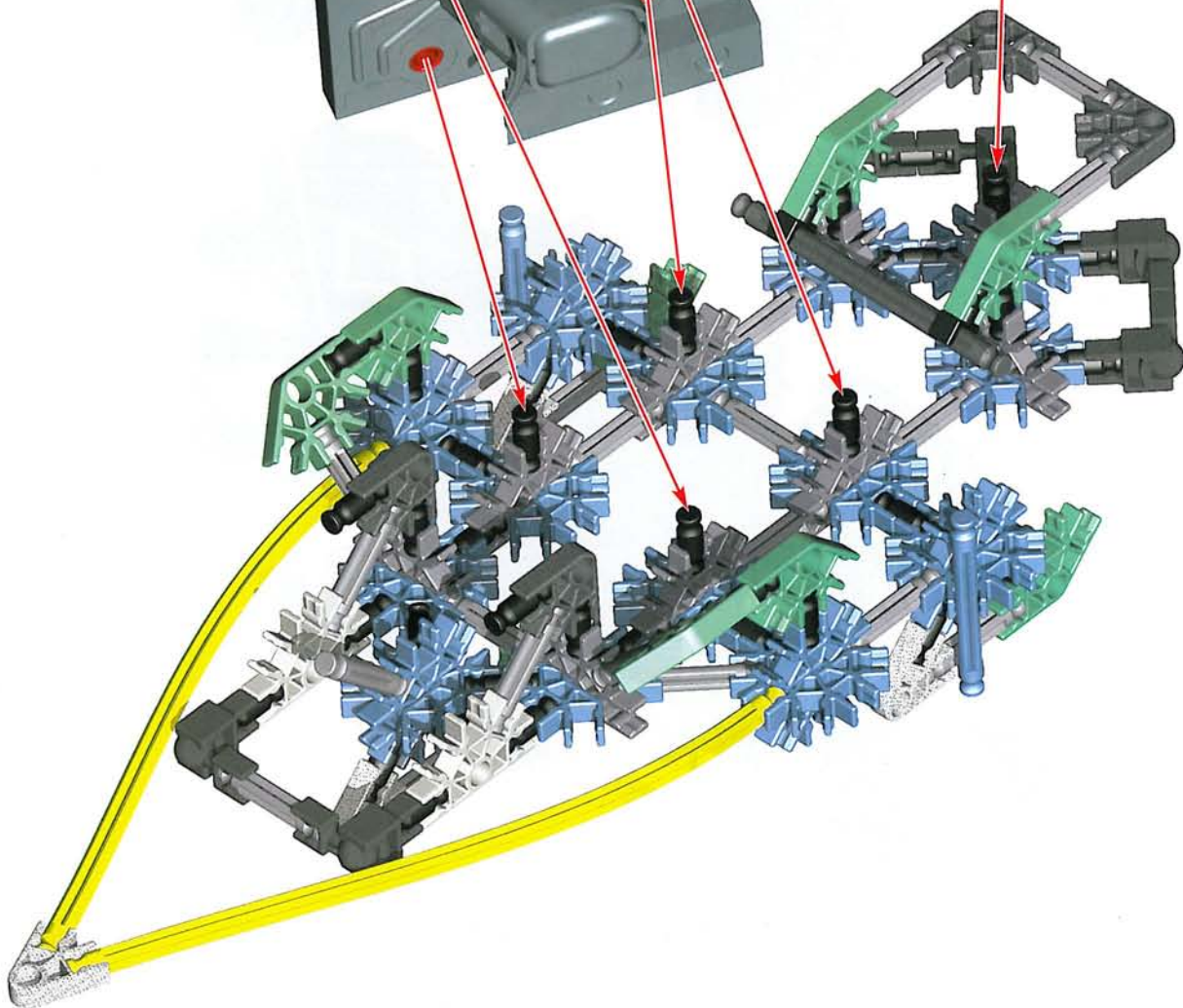

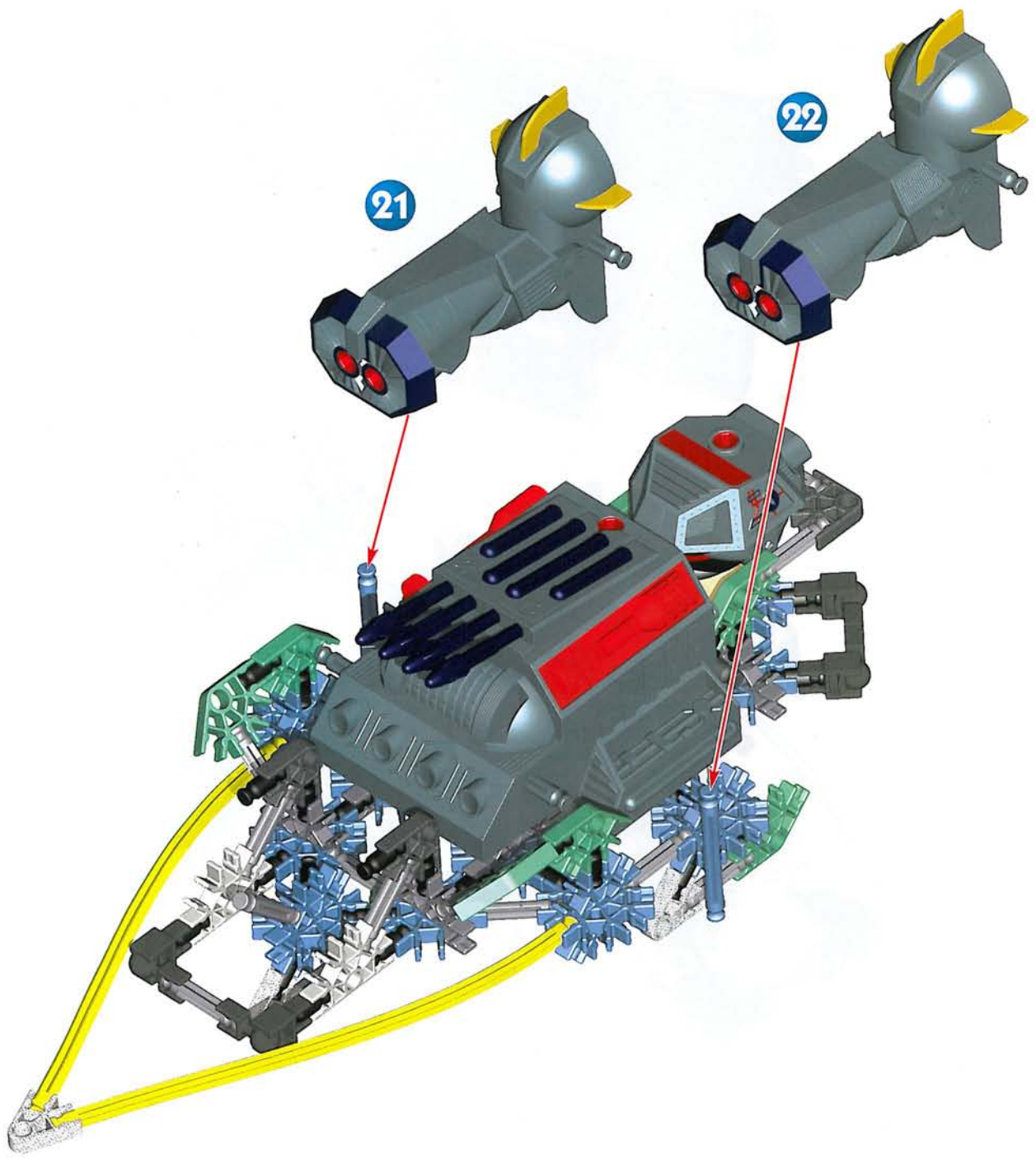

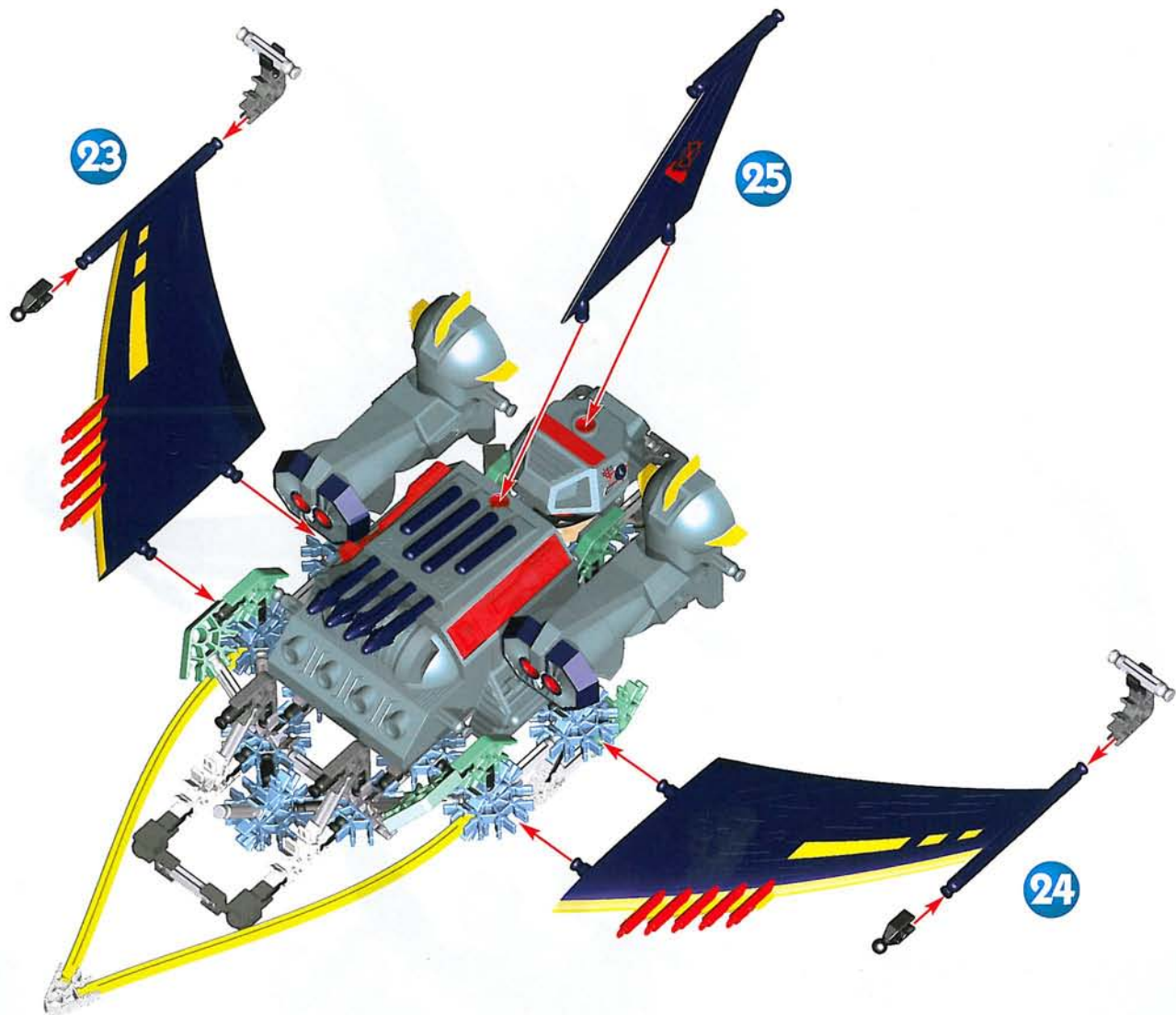

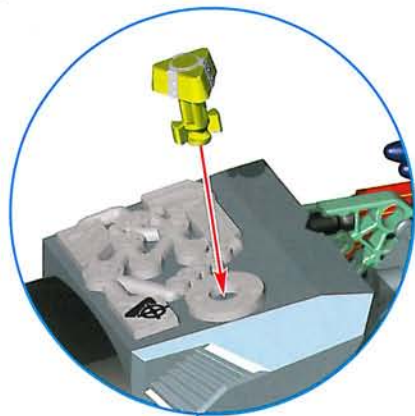

26

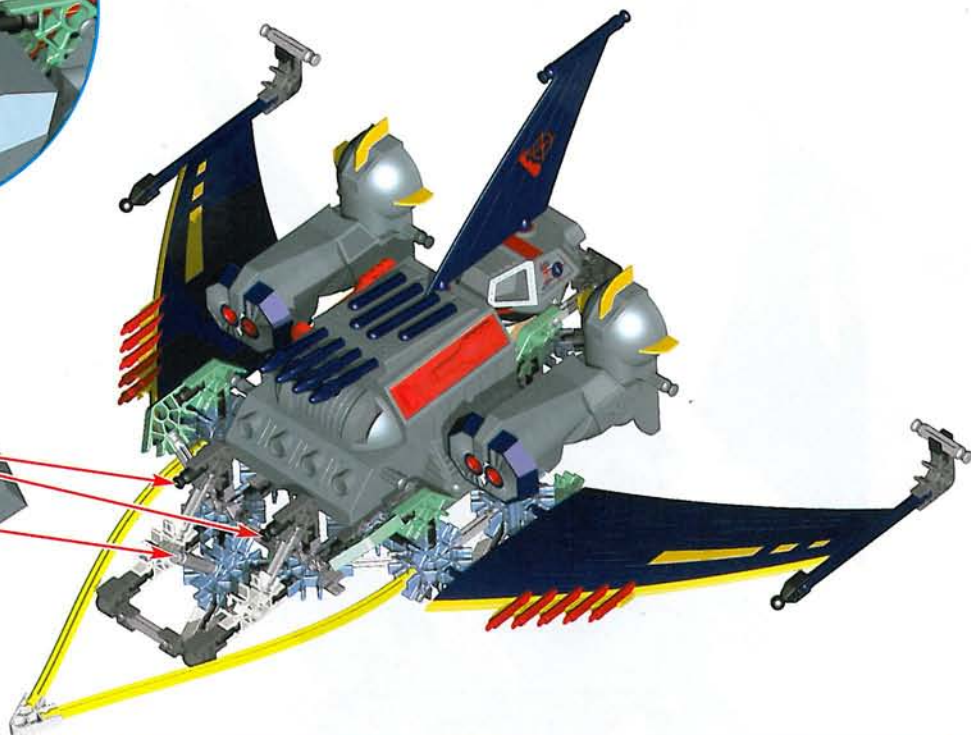
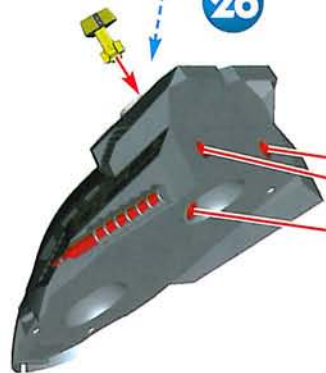

BEFORE SABRIX CAN SNAP HIS HUGE JAWS DOWN ON HIS ENEMY, INFERNOSTRIKE SENDS HIM FLYING WITH A BARRAGE OF MISSILES.

AVANT QUE SABRIX AIT LE TEMPS DE SAISIR L'ENNEMI ENTRE SES ÉNORMES MÂCHOIRES, INFERNOSTRIKE LE BOMBARDE DE MISSILES ET L'ENVOIE VOLTIGER.

OH, NO YOU DON'T!
OH QUE NON,
TU N'OSÉS PAS !

BA-DOONNNNN

WITH SABRIX STUNNED, INFERNOSTRIKE GRABS HIS POWERCORE AND USES HIS OWN PYROTECH POWERCORE AGAIN, THIS TIME CREATING A CAGE OF FIRE AROUND SABRIX. SABRIX ASSOMMÉ, INFERNOSTRIKE S'EMPARÉ DE SON POWERCORE ET FAIT DE NOUVEAU APPEL À SON PROPRE PYROTECH POWERCORE, CRÉANT CETTE FOIS UNE CAGE DE FEU AUTOUR DE SABRIX.

GOTCHA!
TOUCHÉ !

Battle Mode

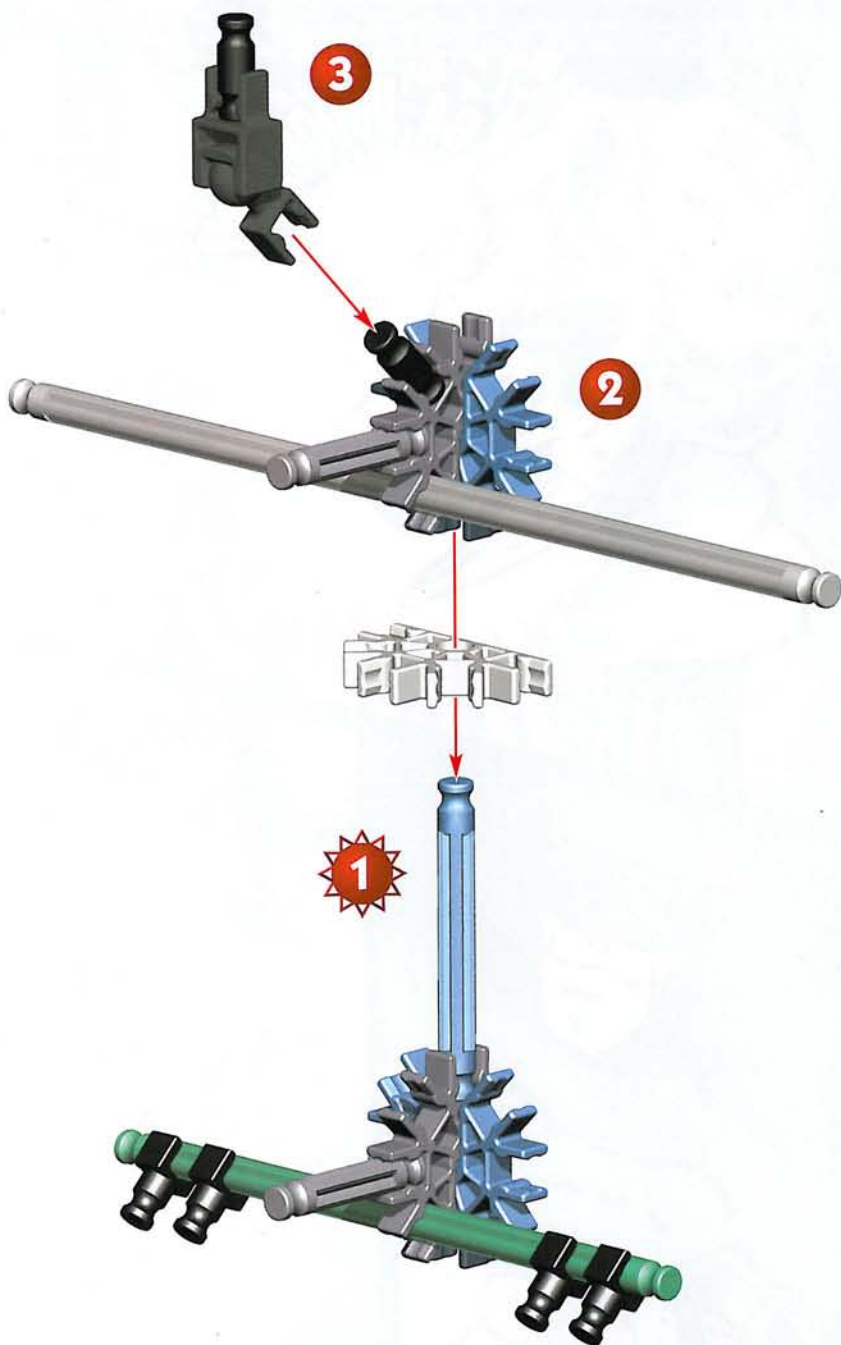

x2

4



5

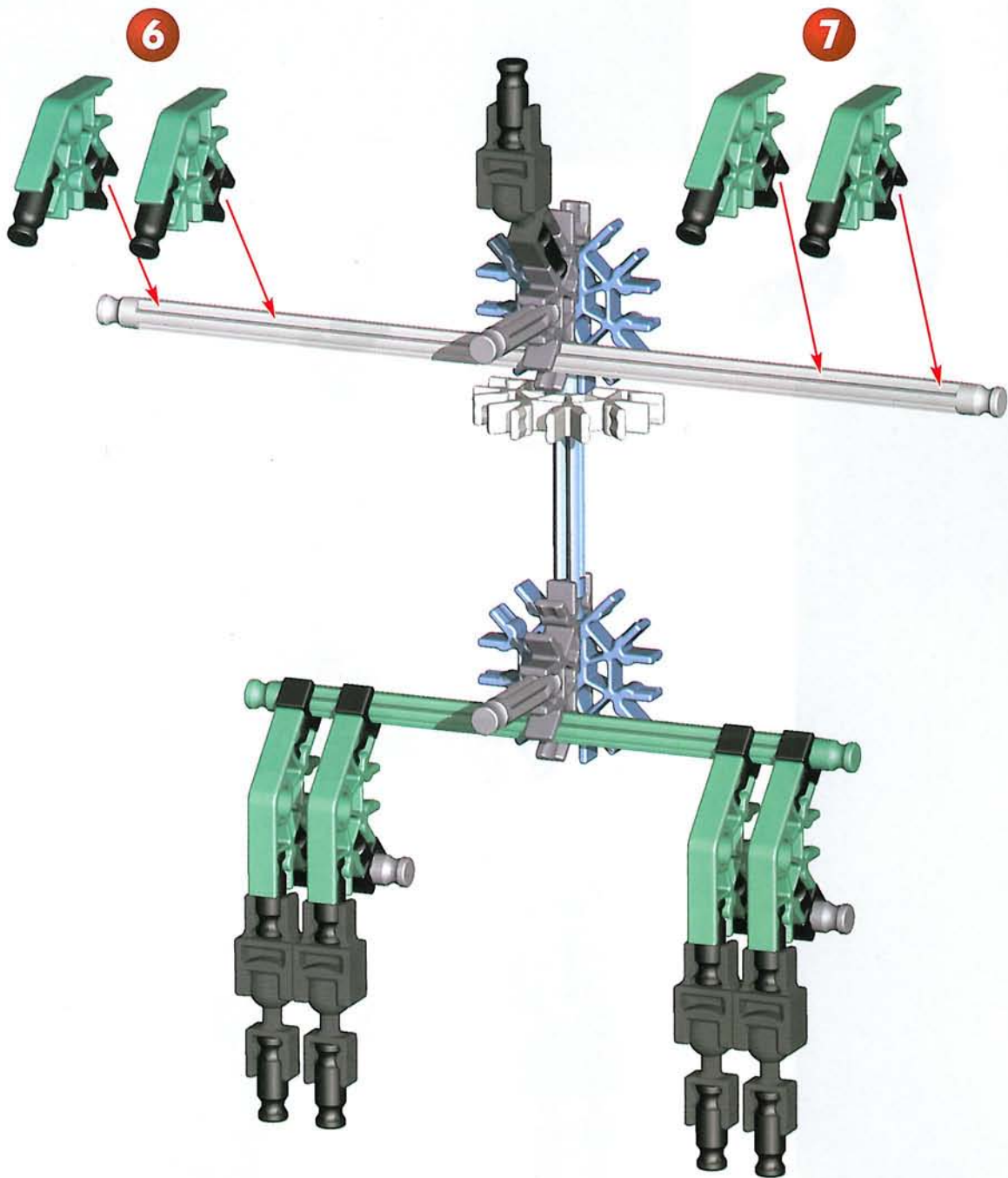

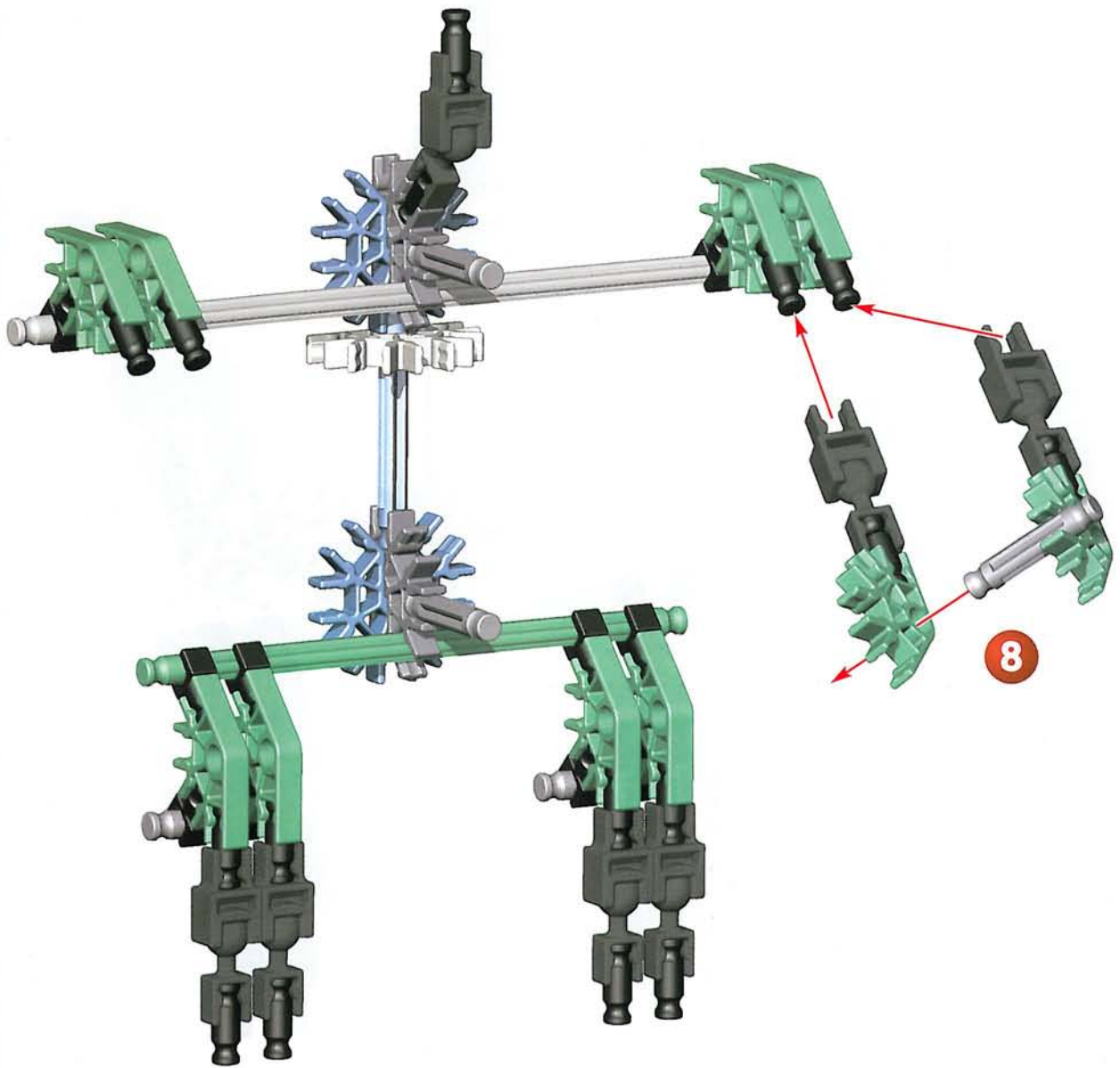

8

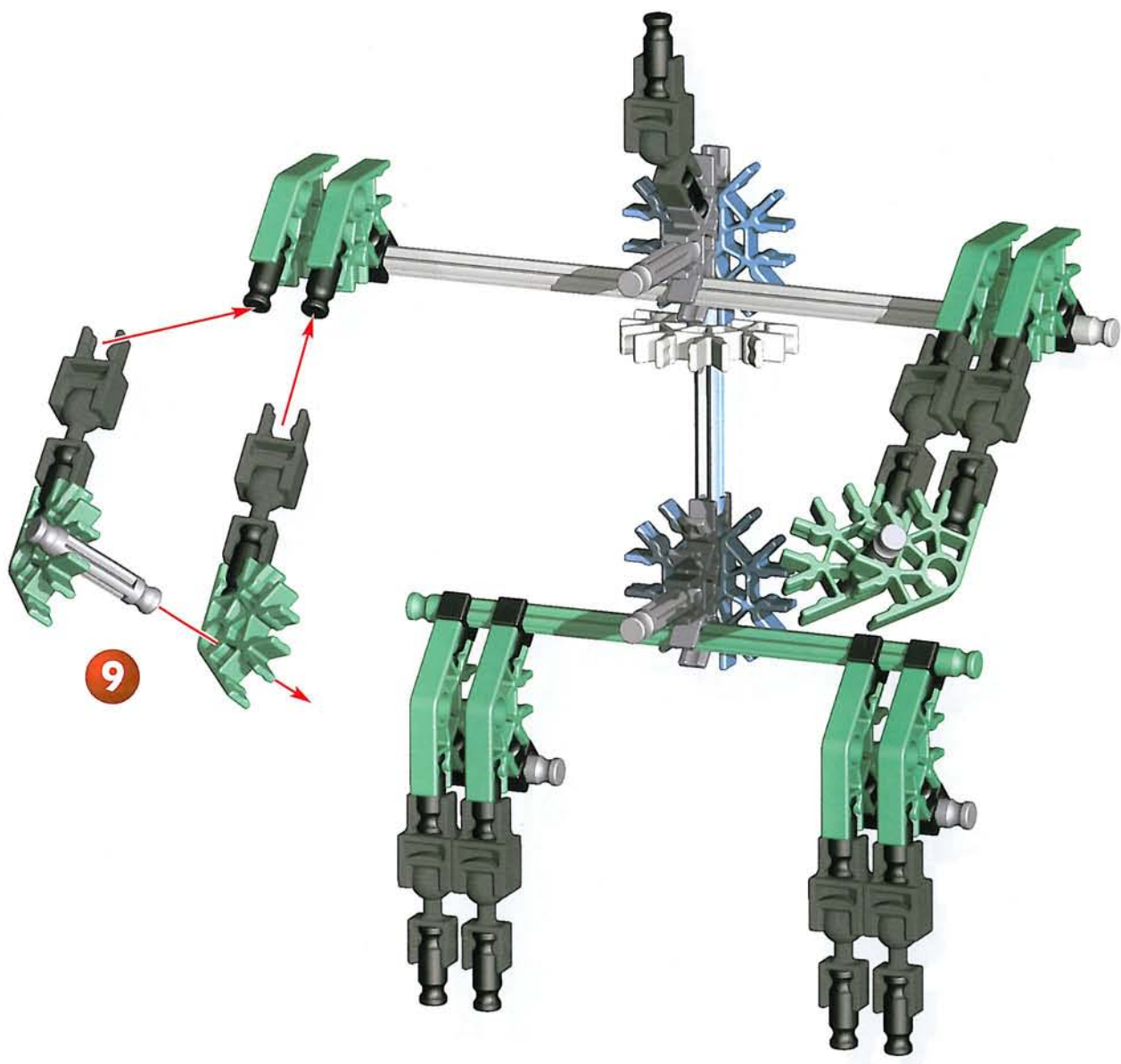

9



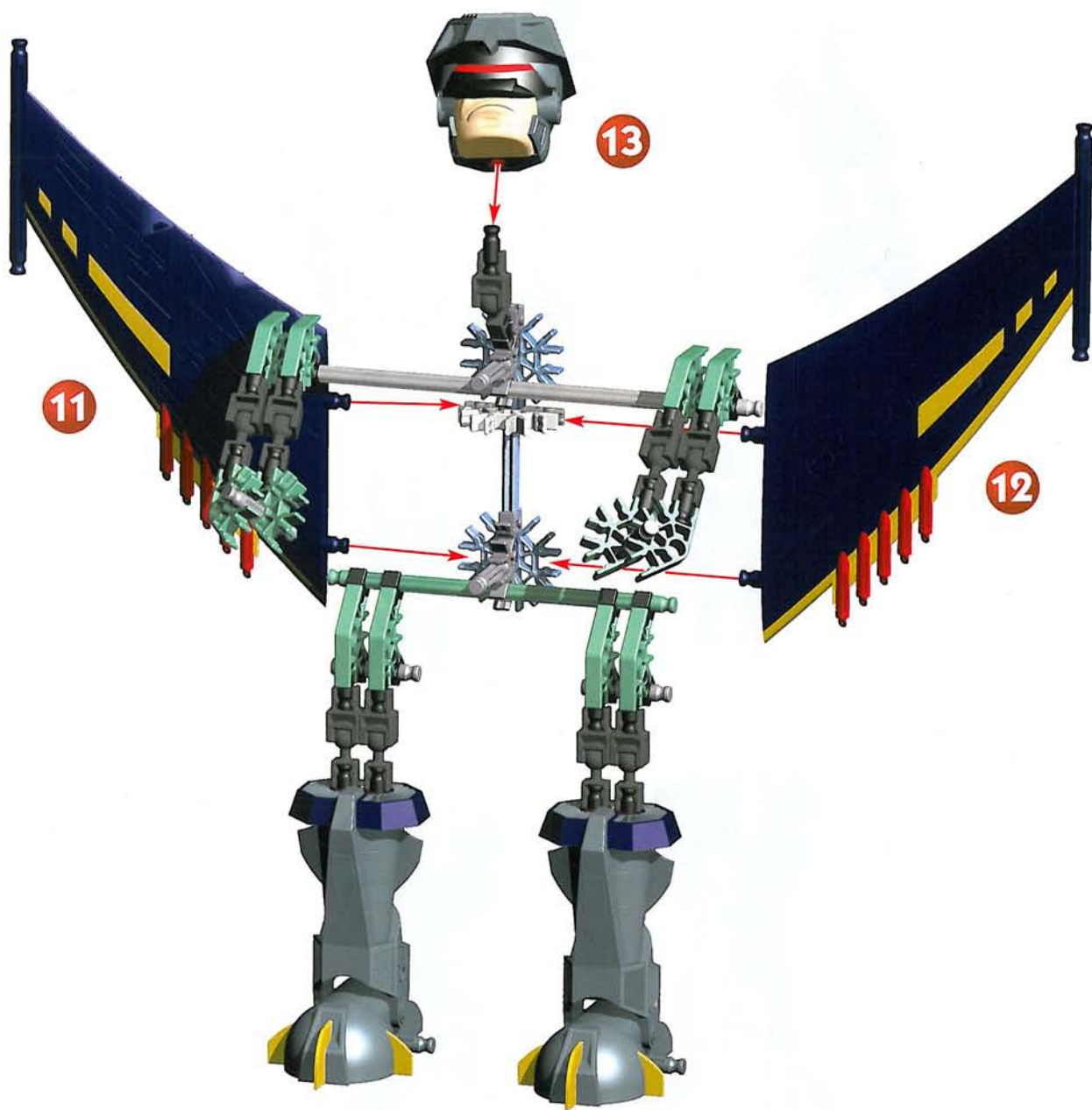

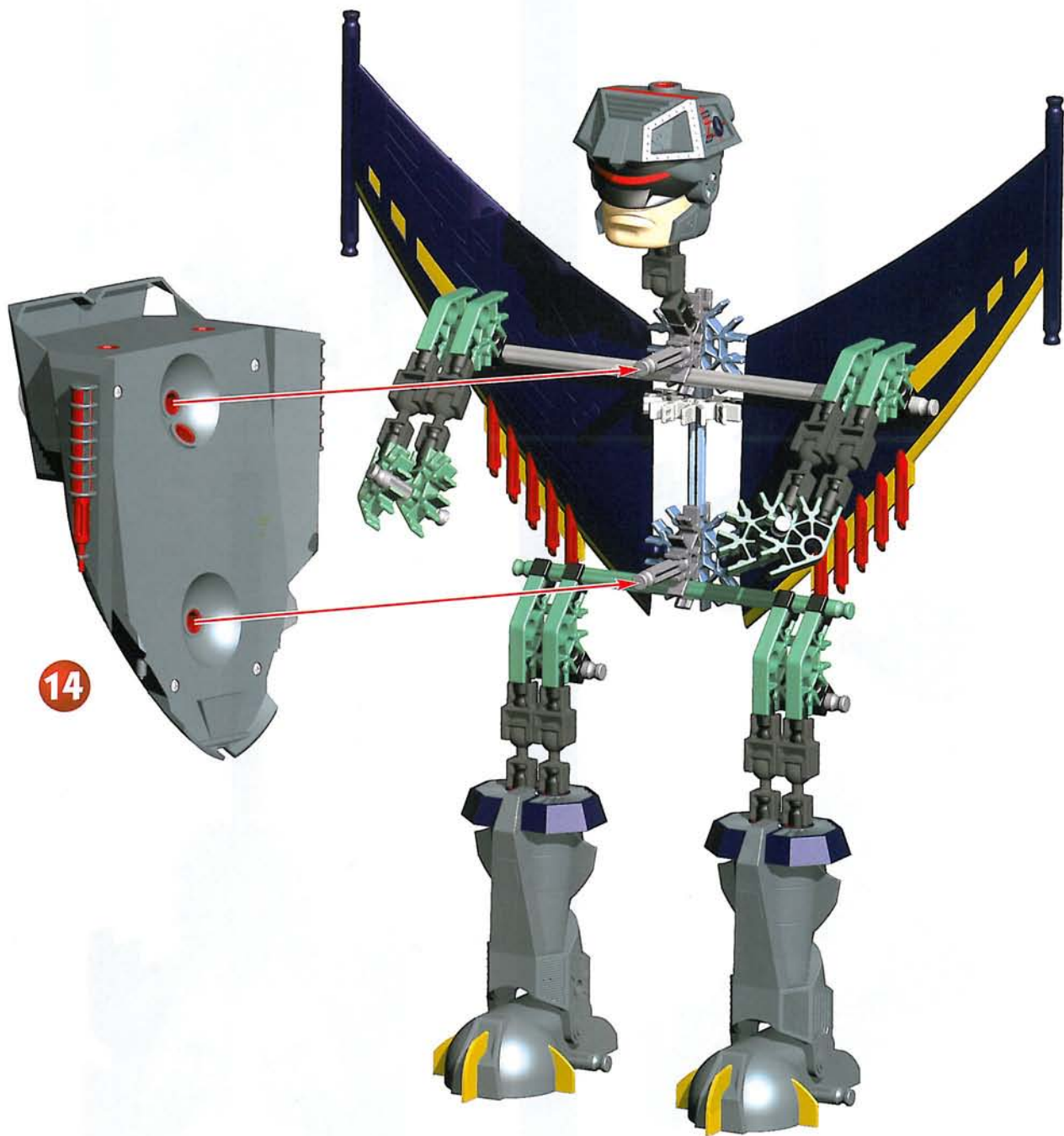

14

15

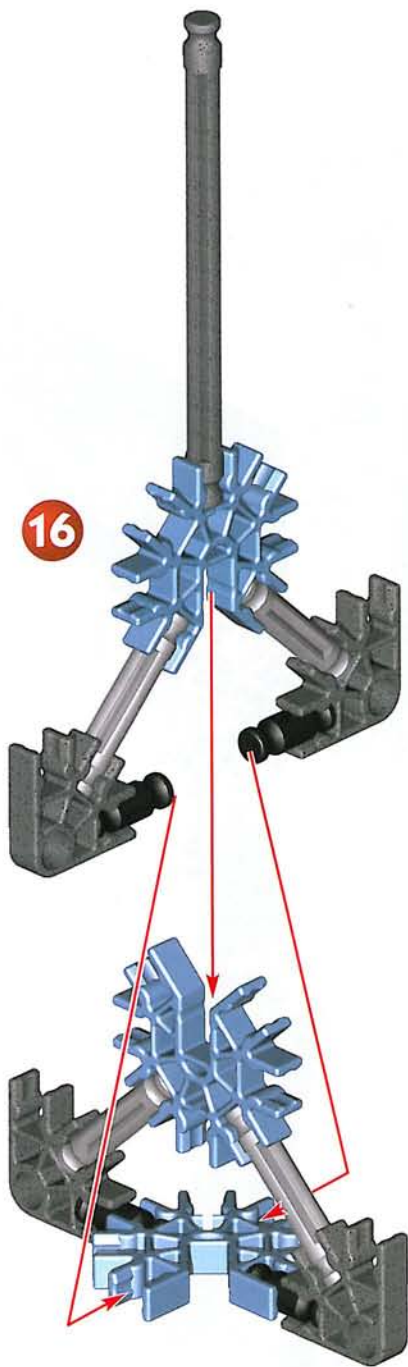

17

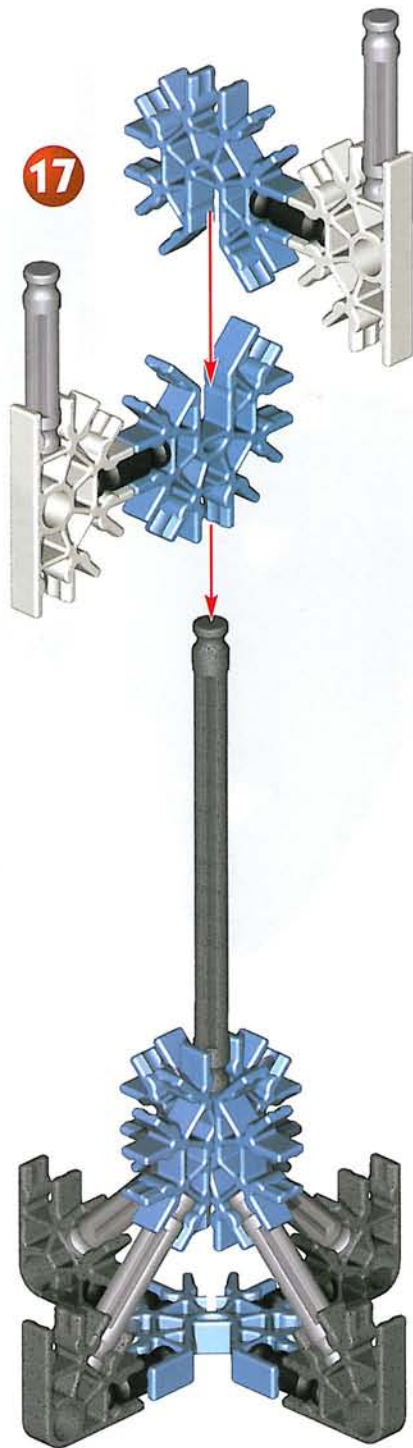

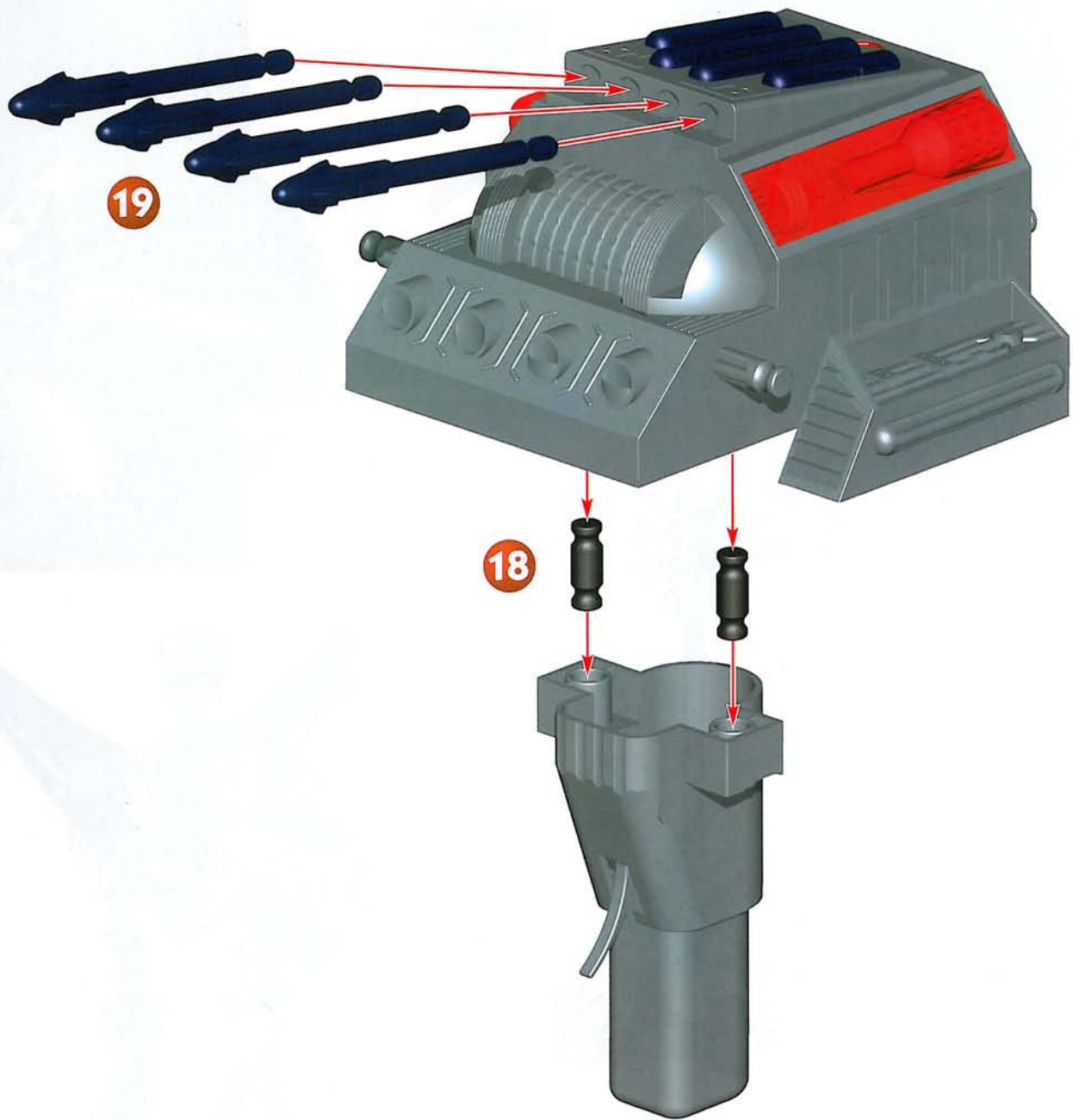

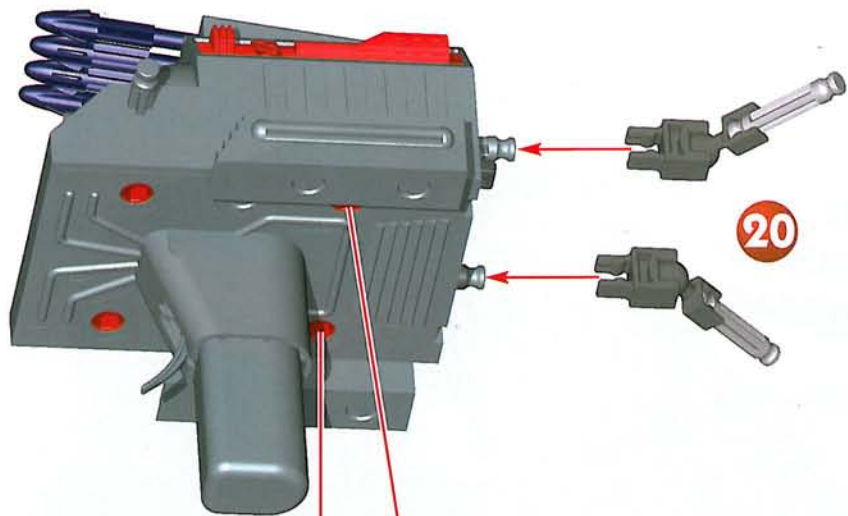

21

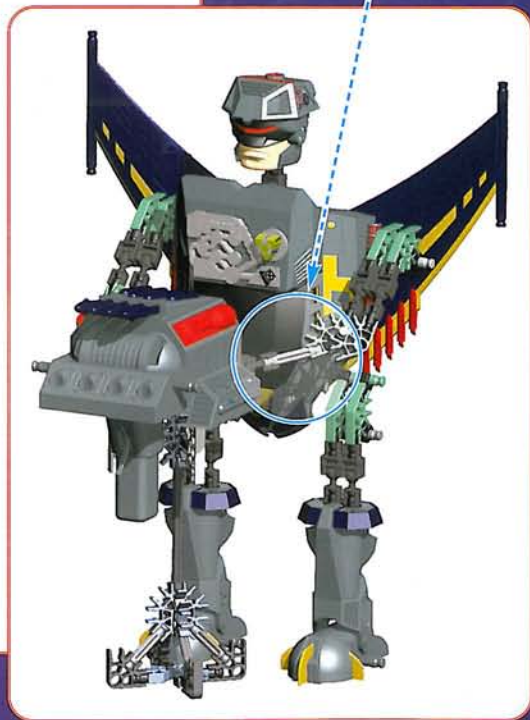
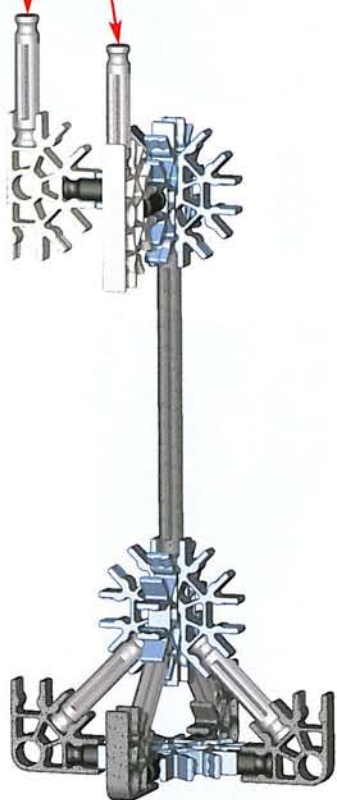



WITH SABRIX CAUGHT, INFERNOSTRIKE,
PLASMA PLIMMING, SHOUTS "REKONSTRUCT!"
AND CHANGES MODES ONCE AGAIN.

SABRIX CAPTURÉ, INFERNOSTRIKE, SON
ADRÉNALINE LE GALVANISANT, HURLE
« REKONSTRUCT ! » ET CHANGE ENCORE
UNE FOIS DE MODE.

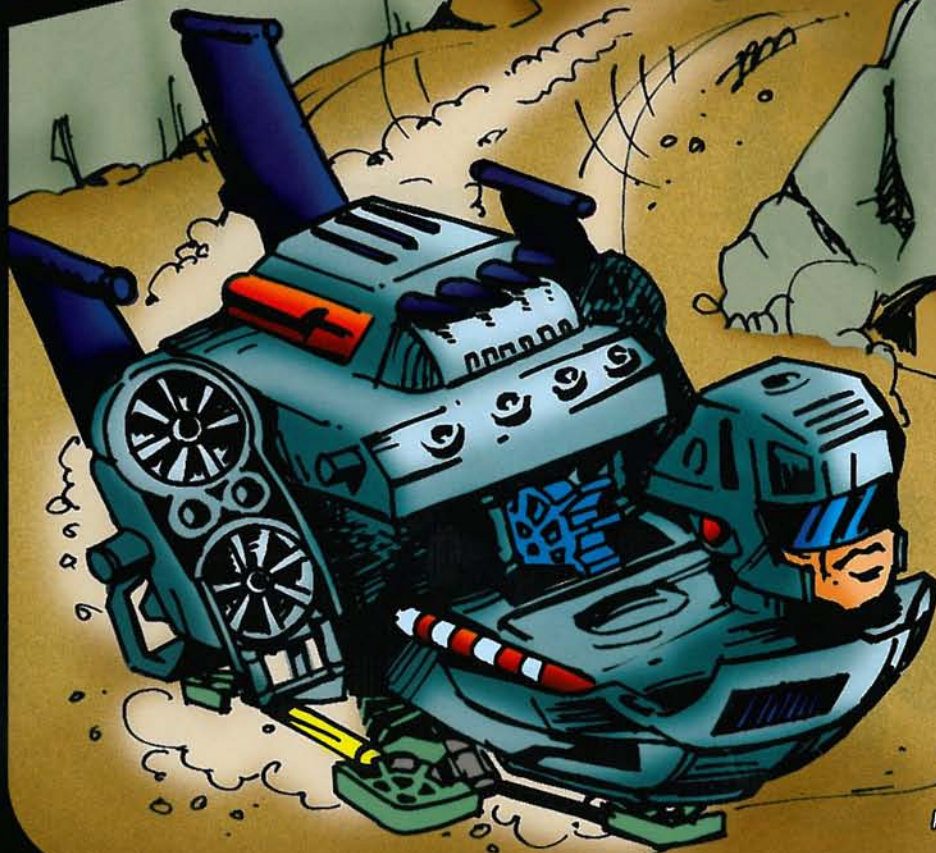

IN HIS NEW MODE, AND WITH SABRIX
TRAPPED, INFERNOSTRIKE DECIDES
TO LOCATE HIS TEAMMATES AND
HOPEFULLY THE REST OF
THE ELITE PILOTS.

DANS SON NOUVEAU
MODE, ET SABRIX PIÉGÉ, INFERNOSTRIKE
DECIDE DE TROUVER L'ENDROIT OÙ
SE TROUVENT SES ÉQUIPIERS, ET SI
POSSIBLE LES AUTRES PILOTES D'ÉLITE.

Scout Mode

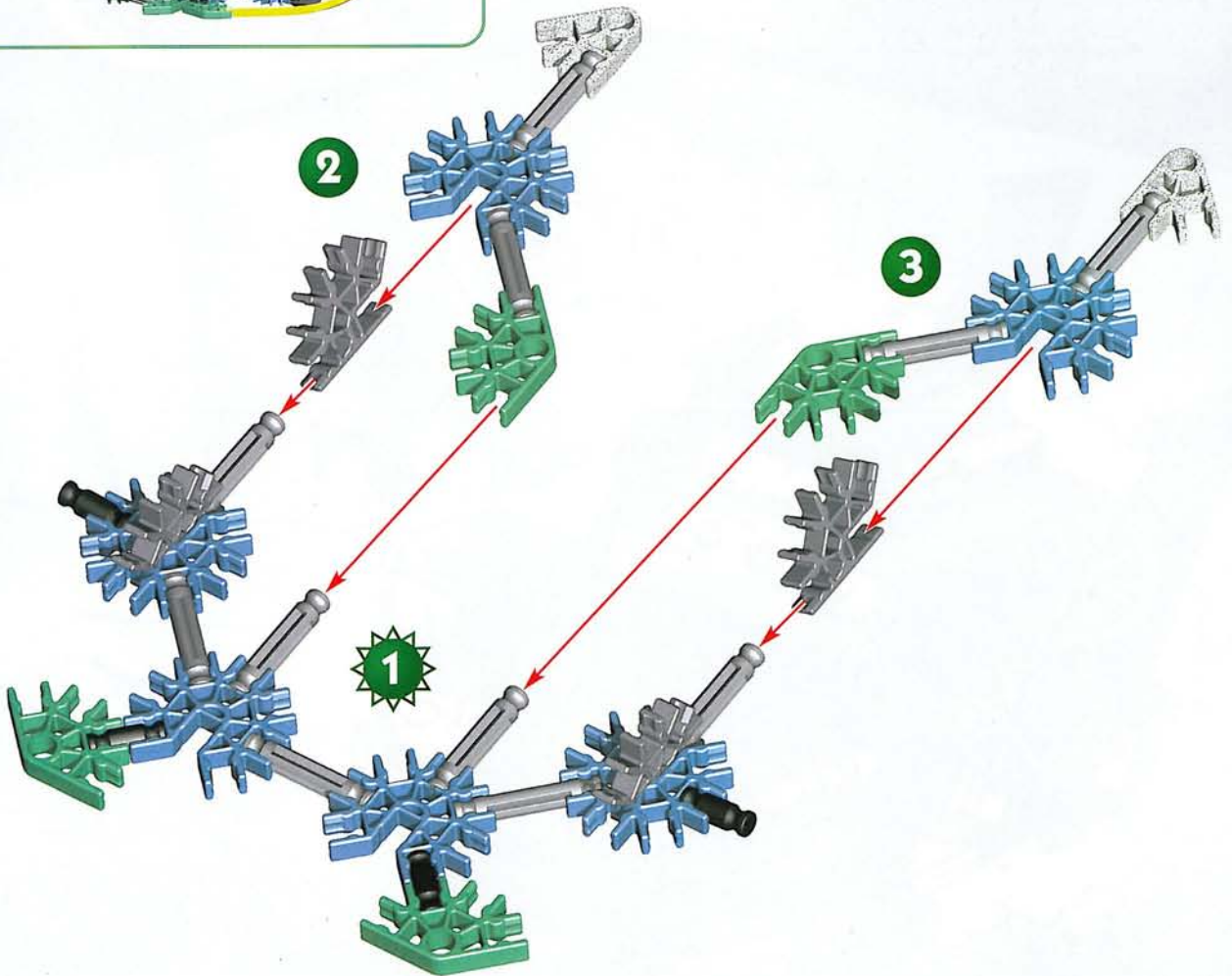

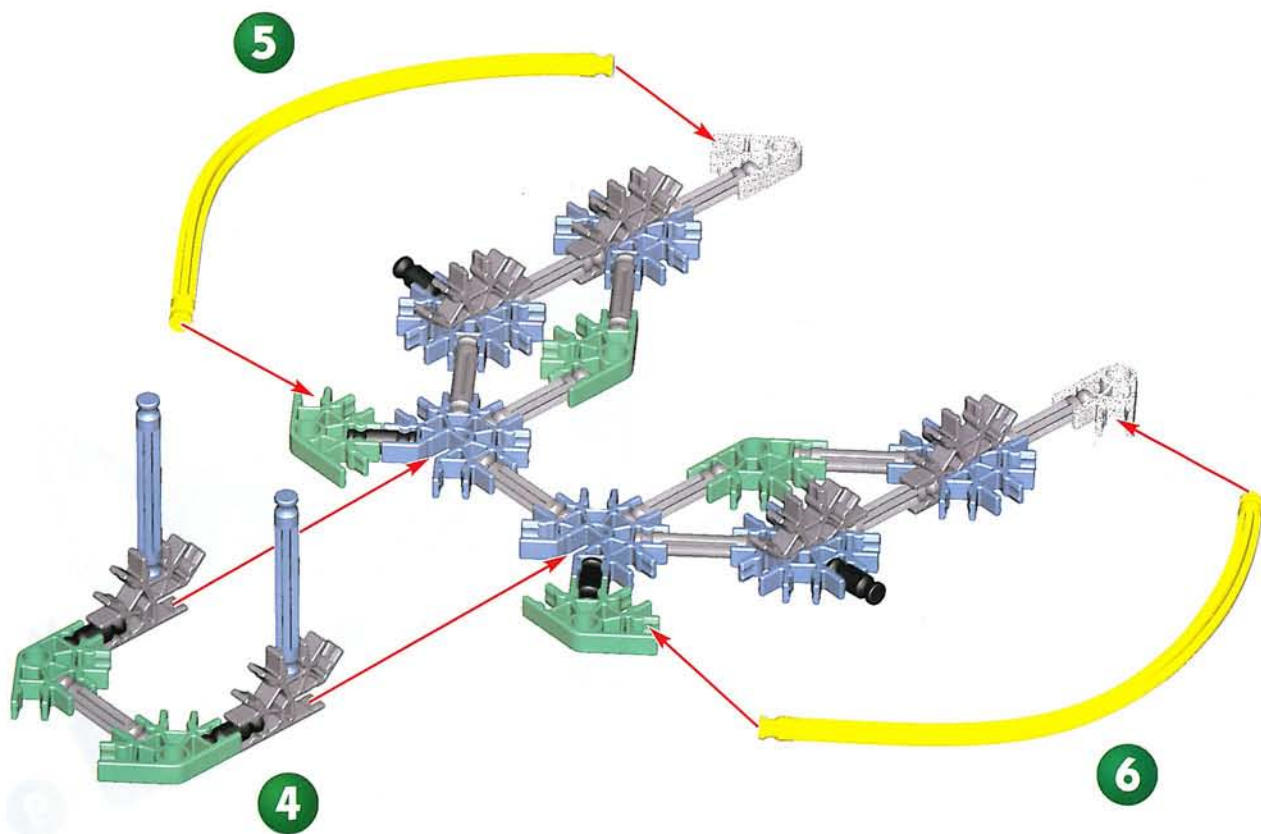

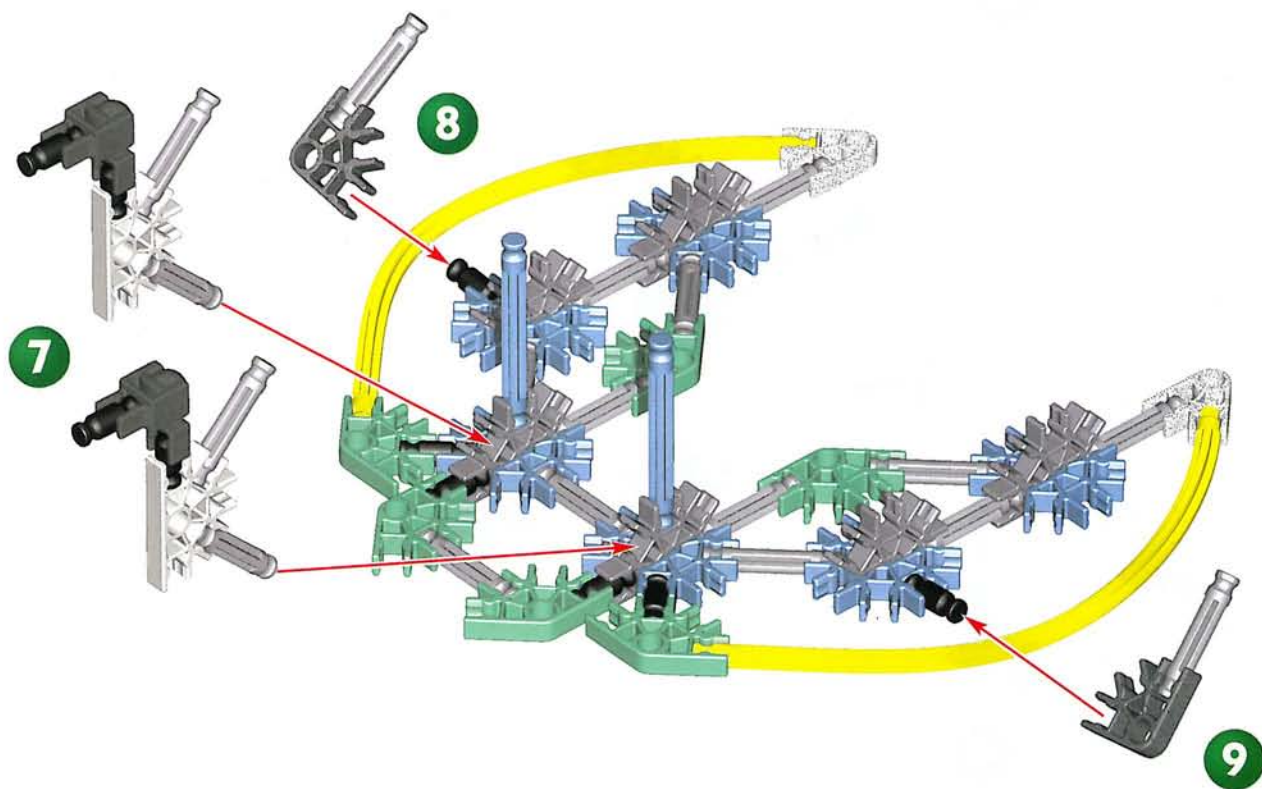

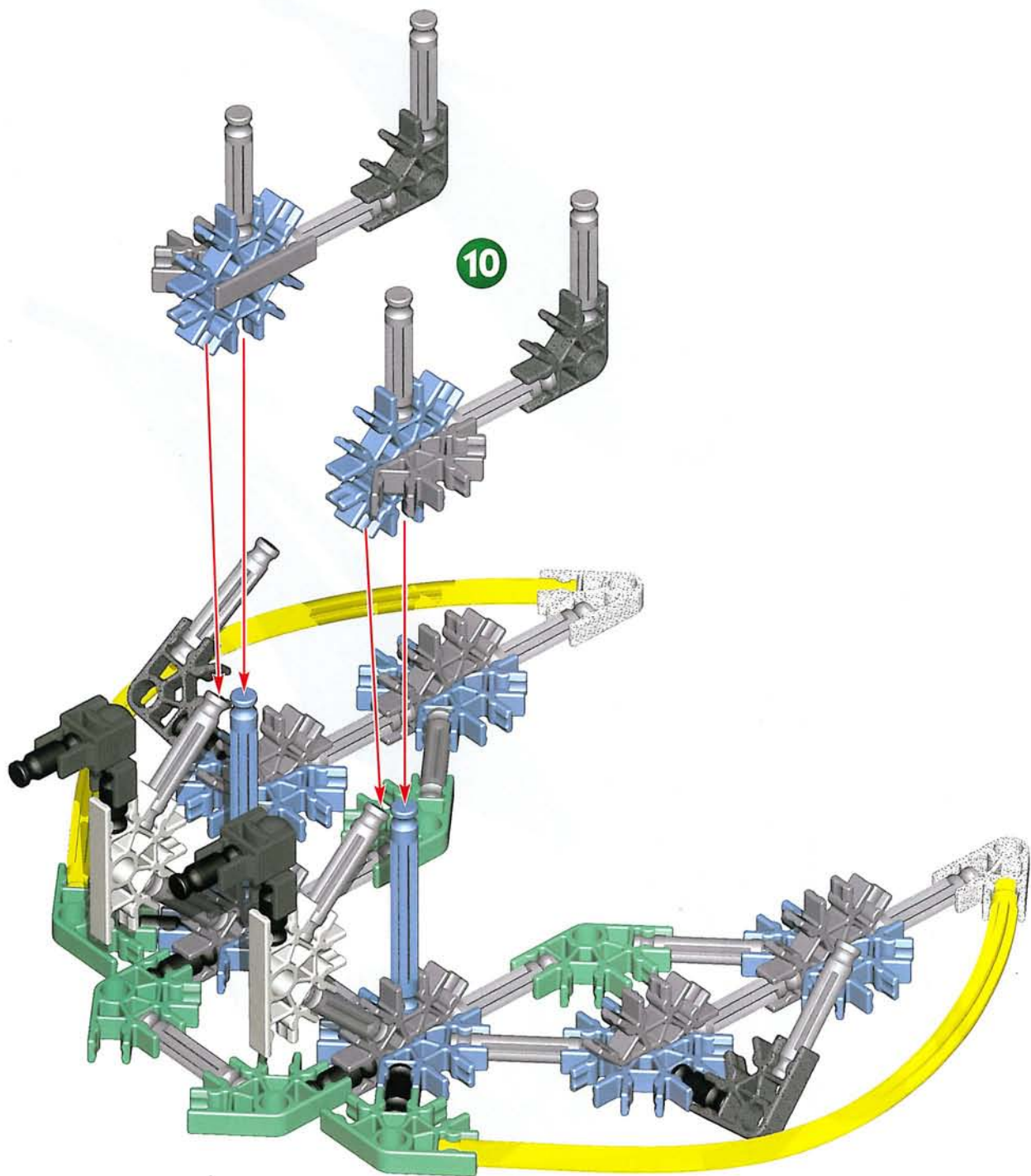

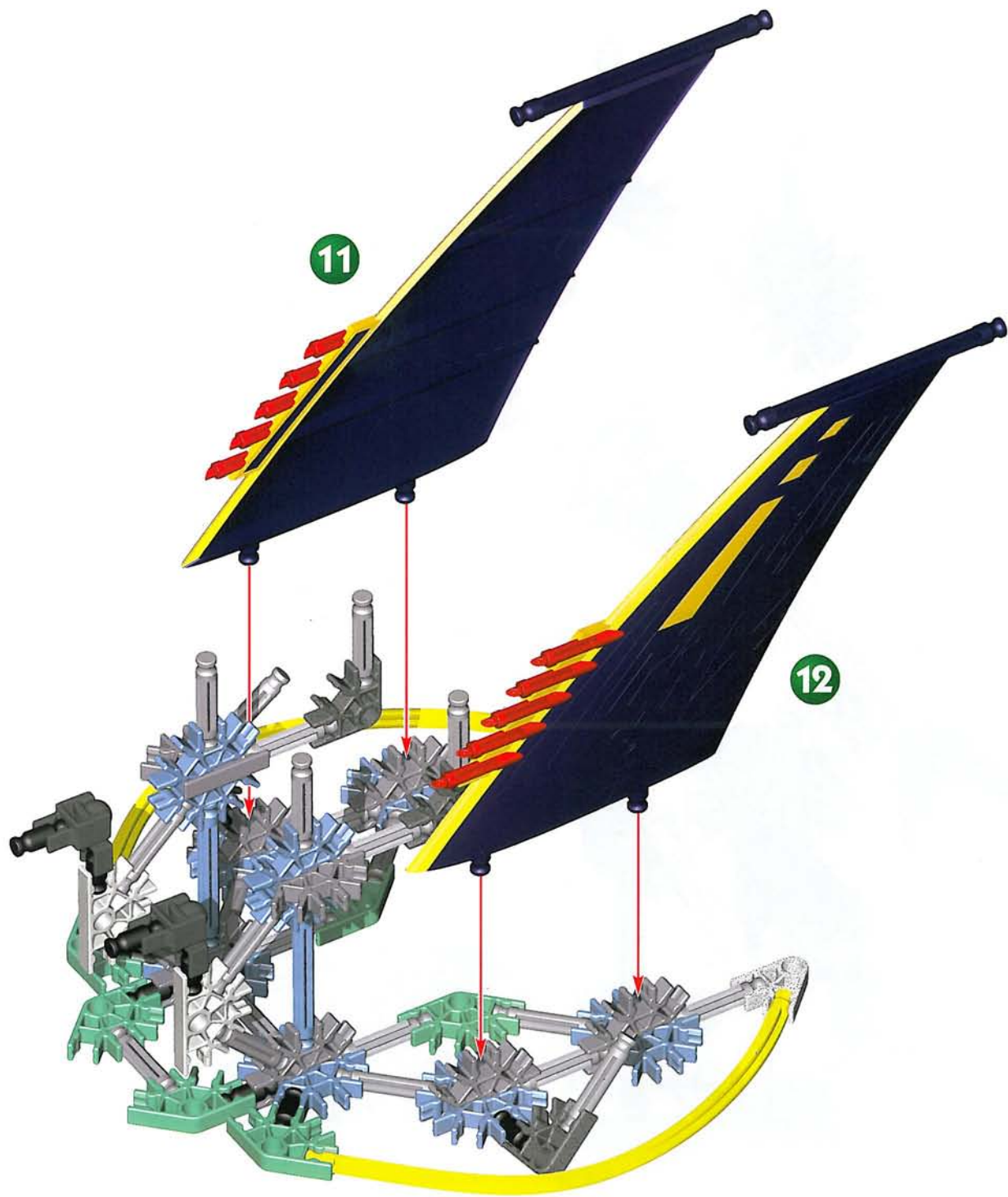

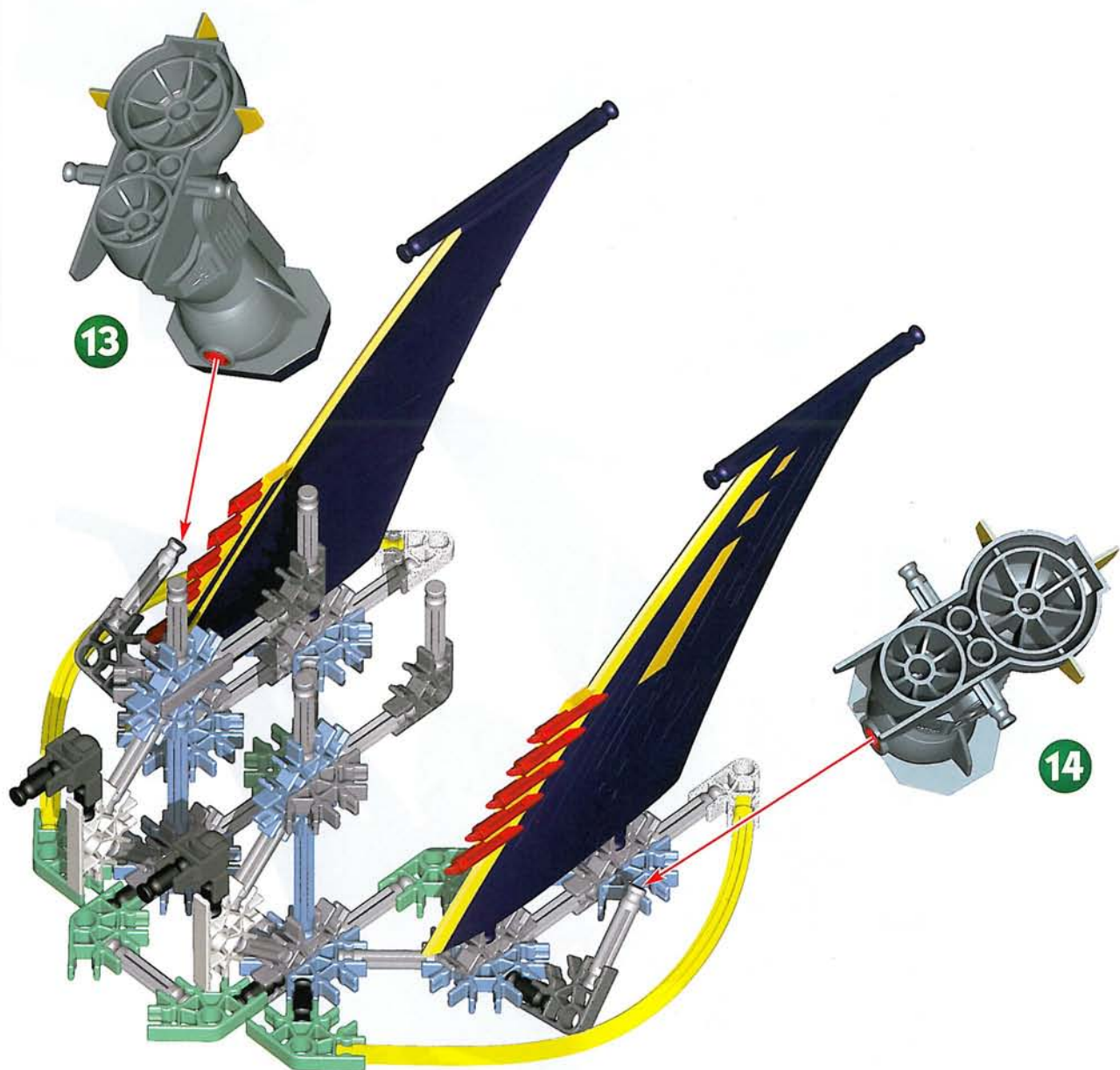

16

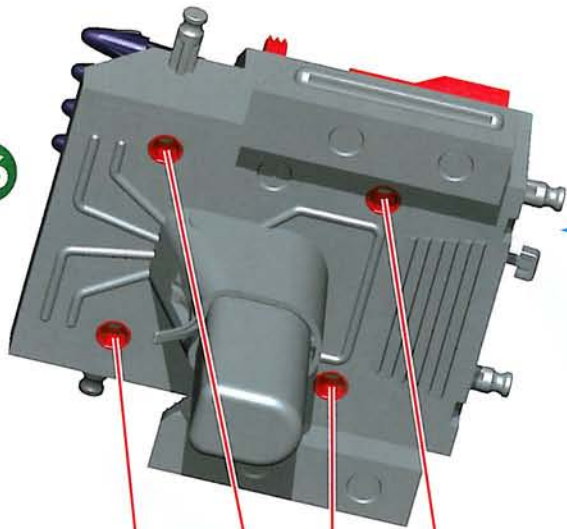

15

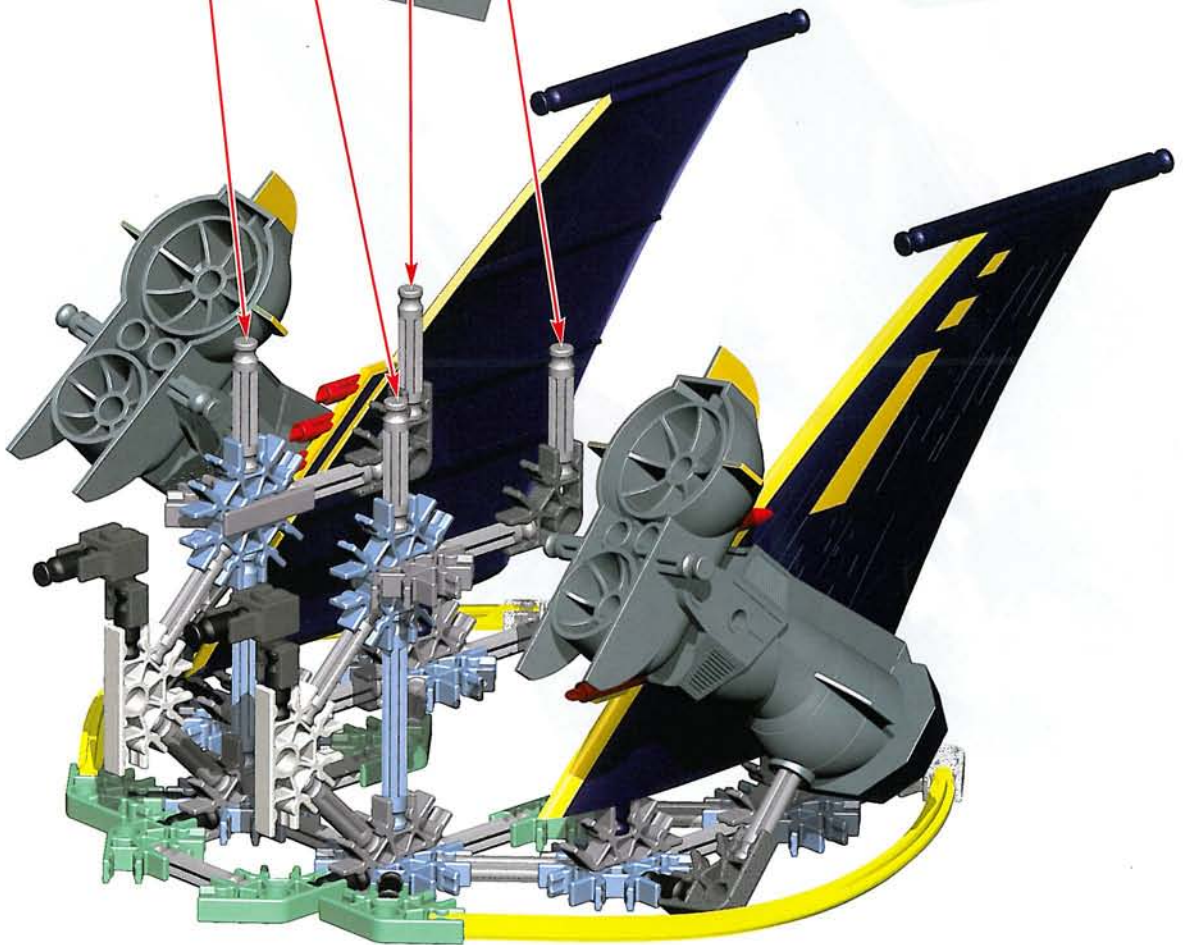

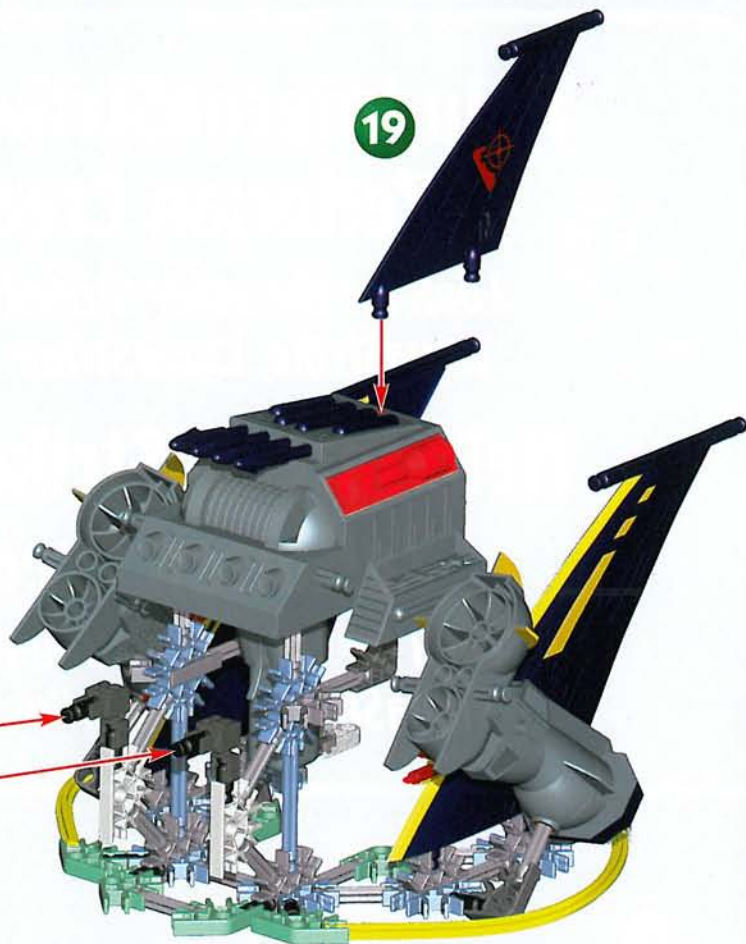
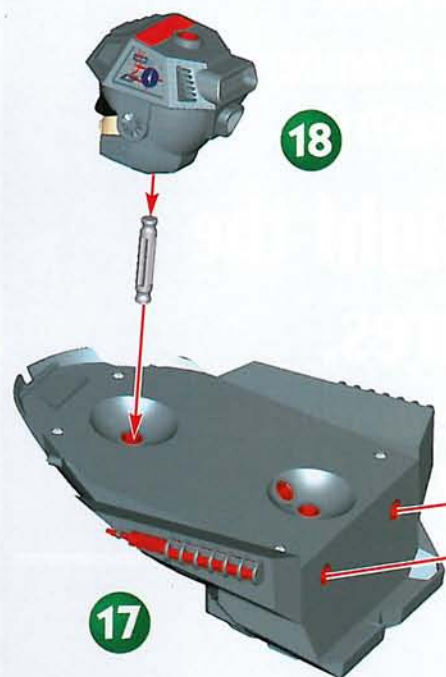

Help InfernoStrike Fight the ZeKorian Creatures.

Look for the other StrikeForce members AquaStrike, CycloStrike, TerraStrike.

Help InfernoStrike Fight the ZeKorian Creatures.

Look for the other StrikeForce members AquaStrike, CycloStrike, TerraStrike.



SPECIAL FEATURES *ATTRIBUTS SPÉCIAUX*

PRESS BUTTON
TO FIRE MISSILES

*APPUYE SUR LE
BOUTON POUR
PROPULSER
LES MISSILES*

PYROTECH POWERCORE™

FIRING MISSILES!
*MISSILES POUVÉANT
ÊTRE PROPULSES !*

PUMPING PLASMA!
*POMPANT DU
PLASMA !*

Caution: Do not launch in the direction of people, animals, or walls; you could cause injury or damage. Never attempt to launch any projectiles other than K'NEX missiles.

Mise en garde : ne pas lancer en direction de personnes, d'animaux, ou de murs pour éviter le risque de blesser quelqu'un ou de provoquer des dégâts. Ne jamais tenter de lancer d'autres projectiles que les missiles K'NEX.

Opgelet: Niet lanceren in de richting van mensen, dieren of muren; je zou letsel of schade kunnen veroorzaken. Nooit proberen om andere projectielen dan K'NEX raketten te lanceren.



PARTS COUNT *NOMBRE DE PIÈCES*



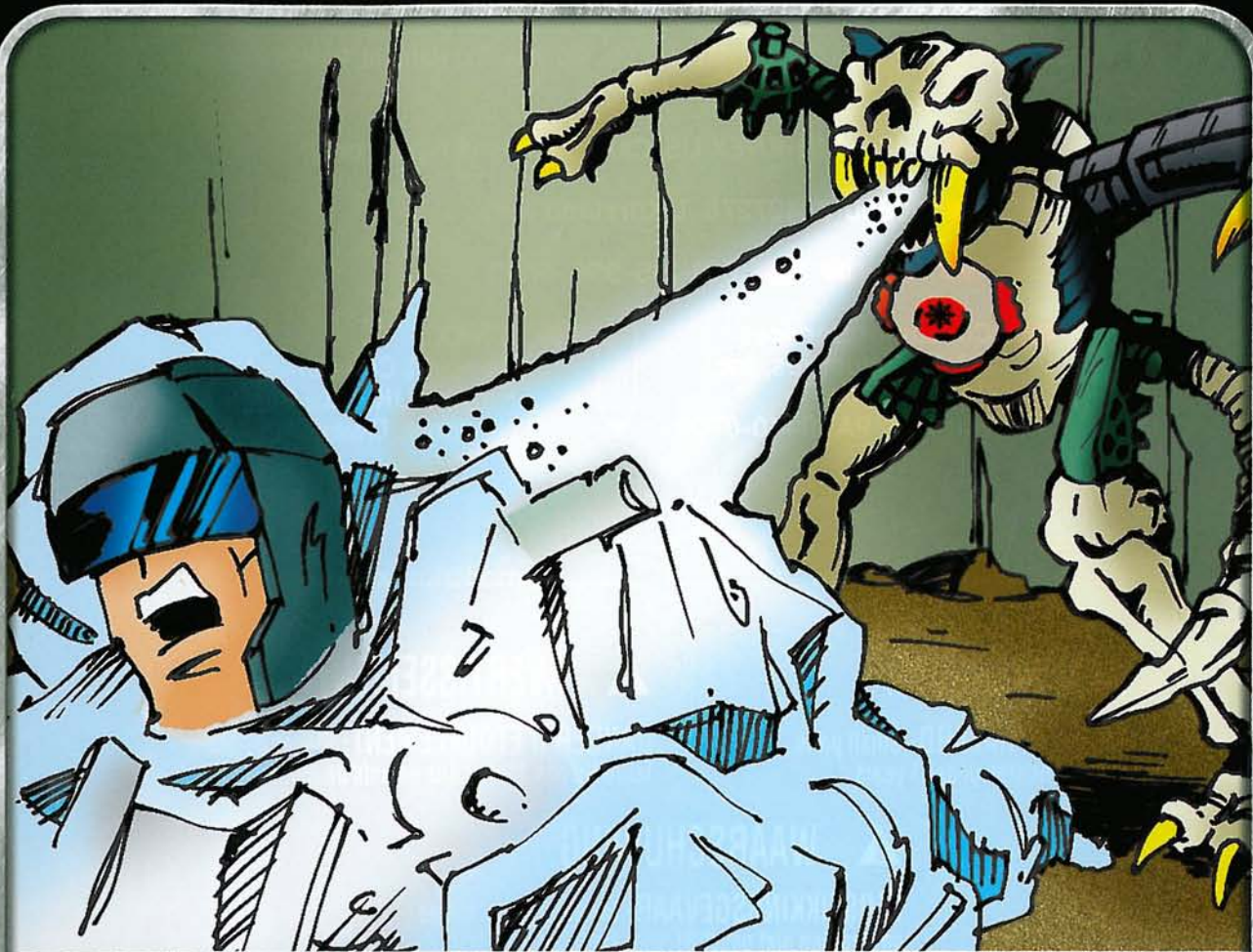

REKONSTRUCTORS.com

Get the Story, Play the Game!
Connais l'histoire, Joue le jeu !



REKONSTRUCTORS.COM



©2004 K'NEX Industries, Inc. P.O. Box 700 Hatfield, PA 19440-0700



US 1-800-KID-KNEX US/Canada only (English only)

GB 00800-22427276 UK/Ireland only

F E D NL 001-215-996-4823

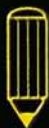

US Consumer Services
K'NEX Industries, Inc.
P.O. Box 700
Hatfield, PA 19440-0700



GB K'NEX
Newport Consumer Services
Hasbro UK Ltd., Caswell Way
Newport, Gwent NP9 0YH



www.knex.com



email@knex.com



WARNING:

CHOKING HAZARD- Small parts.
Not for children under 3 years.



AVERTISSEMENT:

DANGER D'ÉTOUFFEMENT- Pièces de petite
taille Ne pas donner aux enfants de moins de 3 ans.



WAARSCHUWING:

VERSTIKKINGSGEVAAR- In verband met kleine
onderdelen niet geschikt voor kinderen tot 3 jaar.

Printed in China
Imprimerie aux China

Product and colors may vary. Models can be built one at a time. K'NEX is a registered trademark of K'NEX Industries, Inc.
Le produit et les couleurs peuvent varier. La plupart des modèles peuvent être construits un à la fois.
K'NEX est une marque déposée de K'NEX Industries, Inc.

Manufactured under U.S. Patents/Fabriqué sous brevets américains 5,061,219; 5,137,486; 5,199,919; 6,460,572.
Other U.S. and foreign patents pending. Autres brevets américains et étrangers en instance.

Conforms to the Requirements of ASTM Standard Consumer Safety Specification on Toy Safety, F963-96a.
Conforme aux spécifications de sécurité du consommateur sur la sécurité des jouets
de la norme ASTM F963-96a.

Get the Story, Play the Game!
Lis l'histoire, joue le jeu!

REKONSTRUCTORS.com



404420.11-U1-12/03