

12038/48346

REKONSTRUCTORS™

ONE BATTLE... 3 WAYS TO SURVIVE!
UNE BATAILLE... TROIS MOYENS DE SURVIVRE !



K'NEX®

Building System
Système De Construction

8+

DIESEL™



DIESEL™

Commander Jonathon Drake was chosen to be the leader of an elite squadron of pilots sent from Earth in search of a new source of energy. Commander Drake is fearless but not reckless; every decision he makes is based on the safety of his team. When his space cruiser passed through a magnetic storm, the ship crashed on the planet ZeKor. Upon regaining consciousness, Commander Jonathon Drake found his body had combined with the metal of the ship and attached to his new metallic body was a glowing PowerCore. "Commander Jonathon Drake" became "Diesel".

Diesel's PowerCore is Sonic Boom, allowing him to send sonic pulses from his glowing eyes. These pulses produce ground shaking earthquakes that make the enemy fall over, giving the ReKconstructors team the chance to attack or escape. Diesel's careful leadership, fearless nature and incredible earth shaking power make him the ideal commander of the ReKconstructors team.

Le commandant Jonathon Drake a été choisi pour être à la tête d'une escadrille de pilotes d'élite envoyés en mission de la Terre pour trouver une nouvelle source d'énergie. Le commandant Drake n'a peur de rien, mais n'est pas une tête brûlée ; chaque décision qu'il prend tient compte de la sécurité de son équipe. Lorsque son vaisseau spatial a traversé une tempête magnétique, il s'est écrasé sur la planète ZeKor. En reprenant connaissance, le commandant Jonathon Drake a découvert que son corps avait fusionné avec le métal du vaisseau, et que, fixée à ce nouveau corps métallique, rayonnait un PowerCore. C'est ainsi que le « commandant Jonathon Drake » est devenu « Diesel ».

Le PowerCore de Diesel est le Sonic Boom, qui lui permet d'envoyer des pulsions soniques de ses yeux luisants. Ces pulsions entraînent des tremblements terribles qui font trébucher et tomber l'ennemi, donnant à l'équipe des ReKconstructors l'occasion d'attaquer ou de fuir. Le leadership avisé de Diesel, sa nature hardie et son incroyable pouvoir de faire trembler le sol font de lui le commandant idéal de l'équipe des ReKconstructors.



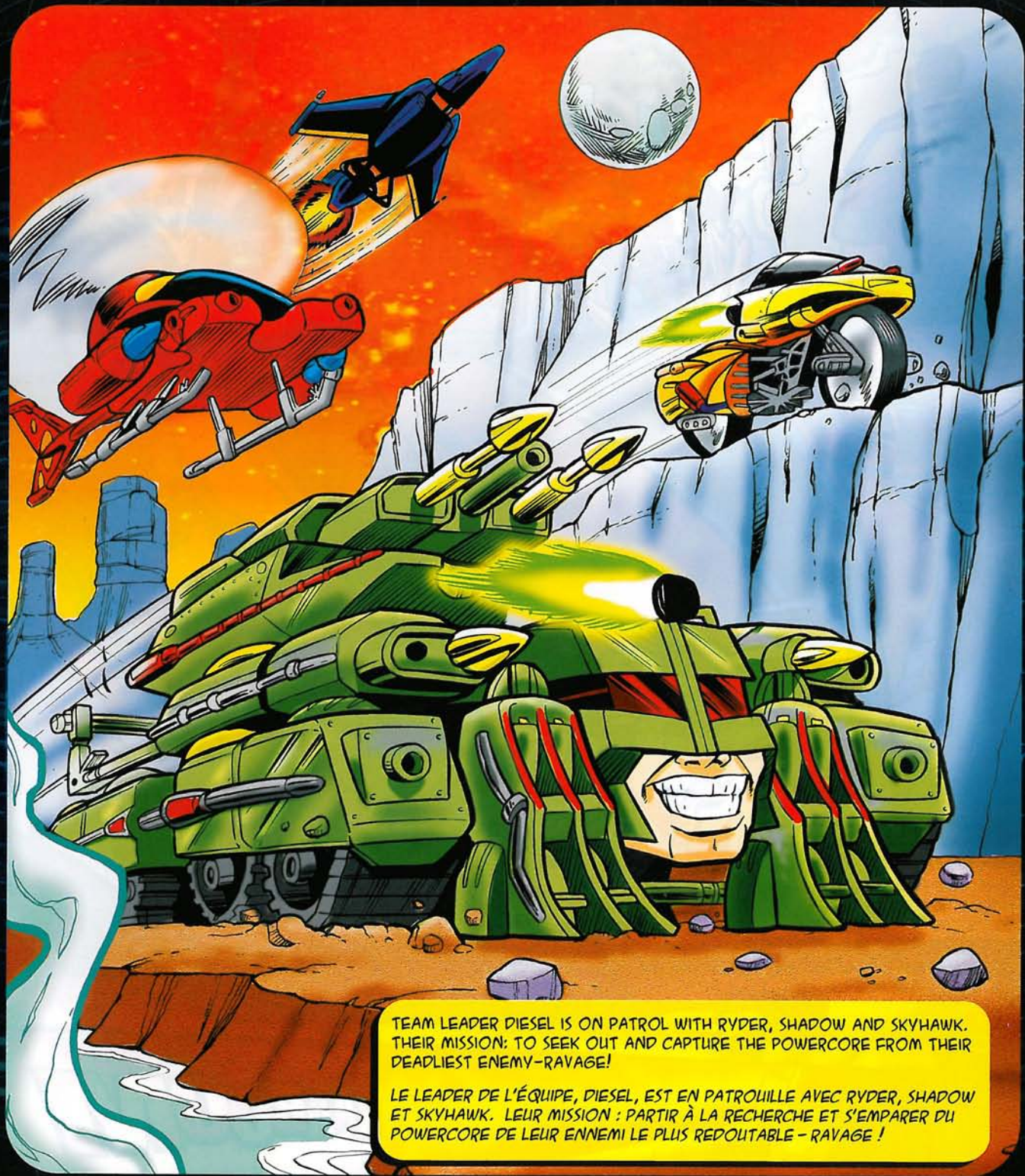

TEAM LEADER DIESEL IS ON PATROL WITH RYDER, SHADOW AND SKYHAWK. THEIR MISSION: TO SEEK OUT AND CAPTURE THE POWERCORE FROM THEIR DEADLIEST ENEMY—RAVAGE!

LE LEADER DE L'ÉQUIPE, DIESEL, EST EN PATROUILLE AVEC RYDER, SHADOW ET SKYHAWK. LEUR MISSION : PARTIR À LA RECHERCHE ET S'EMPARER DU POWERCORE DE LEUR ENNEMI LE PLUS REDOUTABLE—RAVAGE !



READY FOR BATTLE, THE TWO TEAMS CONFRONT EACH OTHER!
PRÊTES À LA BATAILLE, LES DEUX ÉQUIPES SE DÉFIENT !

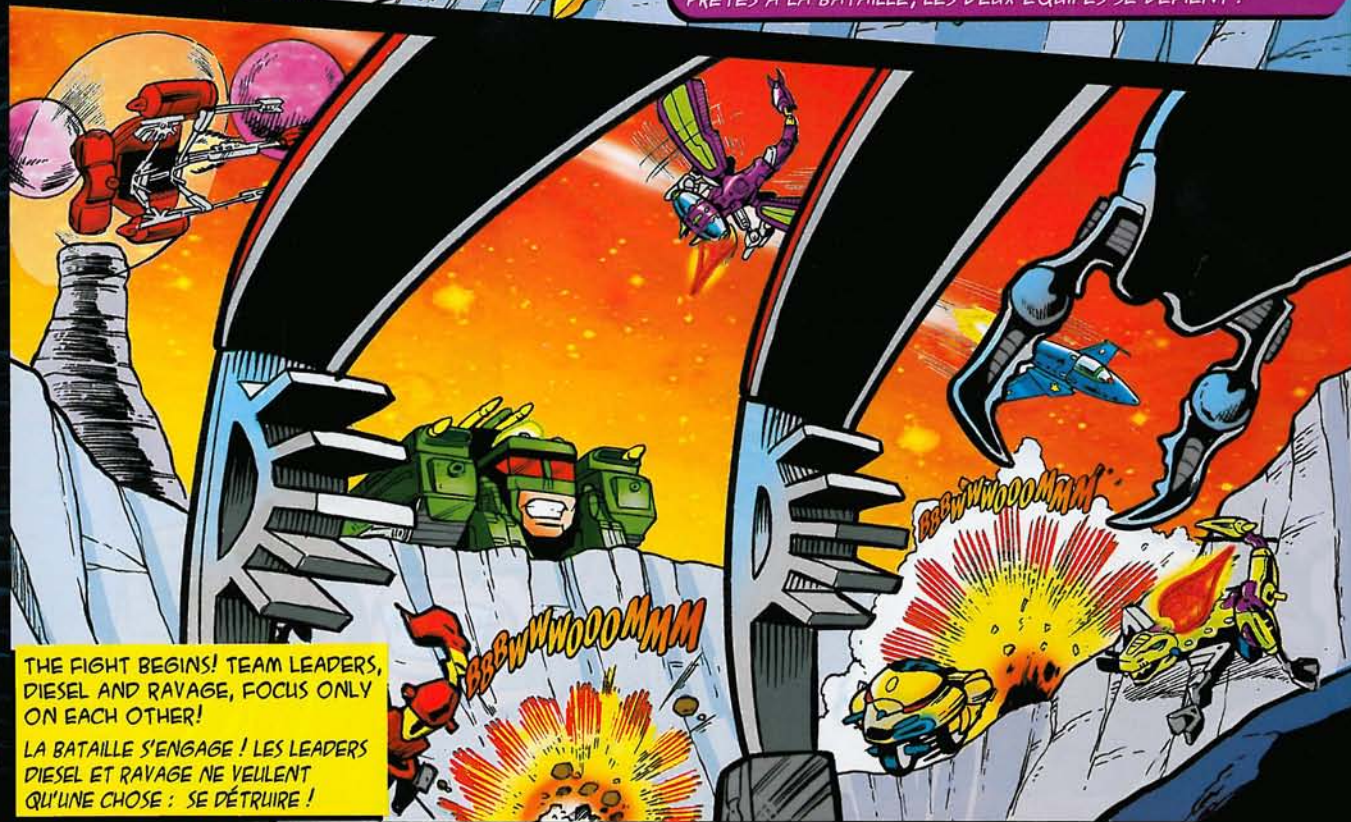

THE FIGHT BEGINS! TEAM LEADERS,
DIESEL AND RAVAGE, FOCUS ONLY
ON EACH OTHER!
LA BATAILLE S'ENGAGE ! LES LEADERS
DIESEL ET RAVAGE NE VEULENT
QU'UNE CHOSE : SE DÉTRUIRE !

DIESEL UNLEASHES HIS SONIC BOOM POWERCORE.
DIESEL DÉCHAÎNE SON POWERCORE DE BANG SUPERSONIQUE.



KAABOOM



DIESEL'S SONIC BOOM DESTROYS THE GROUND BENEATH RAVAGE.
LE BANG SUPERSONIQUE DE DIESEL DÉTRUIT LE TERRAIN OÙ SE TIENT RAVAGE.



DIESEL CAUTIOUSLY APPROACHES THE FALLEN RAVAGE.

DIESEL APPROCHE AVEC MÉFIANCE RAVAGE, QUI EST À TERRE.

"LOOKS LIKE YOU'RE FINISHED, RAVAGE!"
ON DIRAIT BIEN QUE TU ES FINI, RAVAGE!

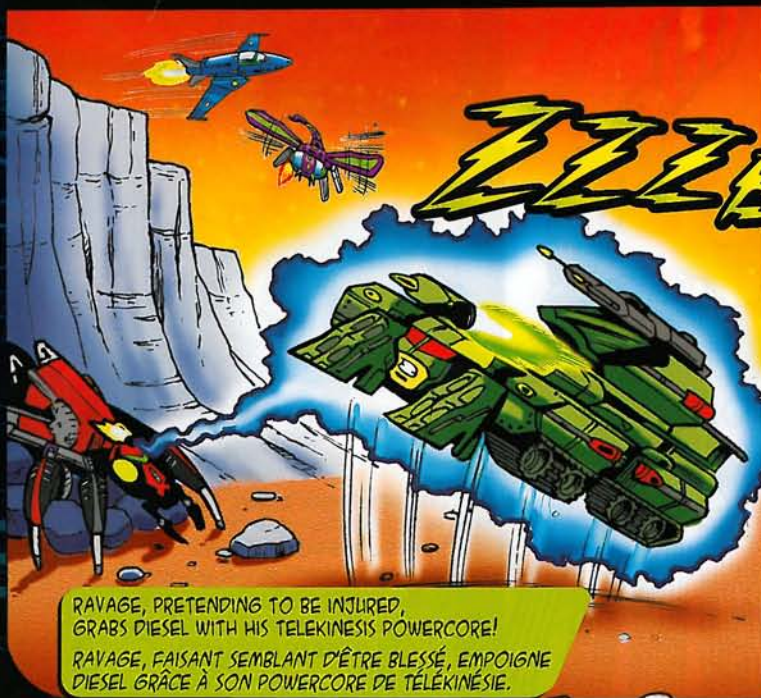

RAVAGE, PRETENDING TO BE INJURED, GRABS DIESEL WITH HIS TELEKINESIS POWERCORE!
RAVAGE, FAISANT SEMBLANT D'ÊTRE BLESSÉ, EMPLOIGNE DIESEL GRÂCE À SON POWERCORE DE TÉLEKINÉSIE.

RAVAGE, USING HIS TELEKINETIC POWER, LIFTS DIESEL HIGH INTO THE AIR.
RAVAGE, SE SERVANT DE SES POUVOIRS DE TÉLEKINÉSIE, SOULÈVE DIESEL HAUT DANS LES AIRS.





CAUGHT
IN RAVAGE'S
TELEKINETIC HOLD,
DIESEL UNLEASHES
HIS HOVERCRAFT MISSILE LAUNCHER.
EMPRISONNÉ DANS LA PRISE TÉLÉKINÉTIQUE
DE RAVAGE, DIESEL LÂCHE LE LANCEUR
DE MISSILES DE SON VAISSAU.

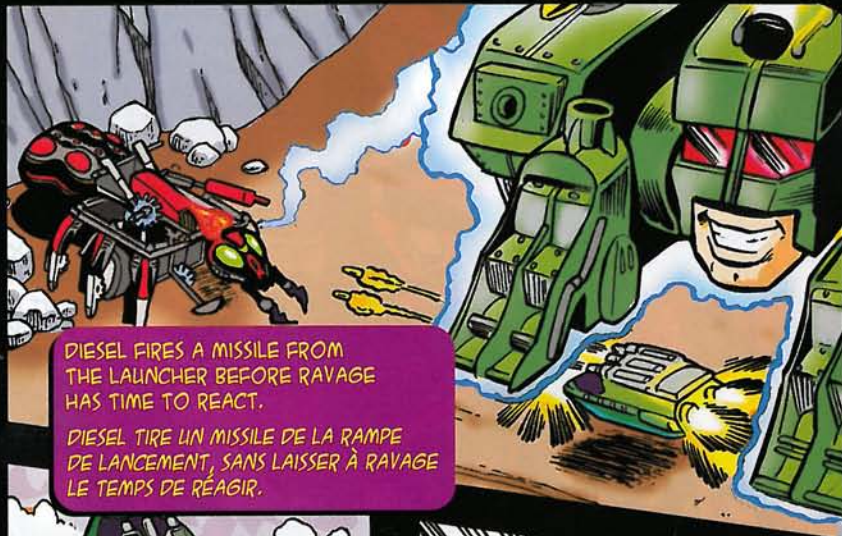

DIESEL FIRES A MISSILE FROM
THE LAUNCHER BEFORE RAVAGE
HAS TIME TO REACT.

DIESEL TIRE UN MISSILE DE LA RAMPE
DE LANCEMENT, SANS LAISSER À RAVAGE
LE TEMPS DE RÉAGIR.



THE HOVERCRAFT
RECONNECTS
WITH DIESEL.
LE VAISSAU SE
RECONNECTE À DIESEL.



RAVAGE'S INJURY BREAKS
HIS TELEKINETIC HOLD ON
DIESEL, MAKING DIESEL FALL.
LES BLESSURES DE RAVAGE ANNIHILENT
LA PRISE TÉLÉKINÉTIQUE QU'IL A SUR
DIESEL, CE QUI ENTRAÎNE LA
CHUTE DE DIESEL.



WHOA!
I HOPE THAT DIDN'T
FEEL AS BAD AS IT LOOKED!
OUI LA LA ! J'ESPÈRE QUE ÇA N'A
PAS FAIT AUSSI MAL QUE L'ON
POURRAIT LE CROIRE
À LE VOIR !



RAVAGE RECOVERS AND FIRES
A MISSILE AT THE FALLEN DIESEL.
RAVAGE RÉCUPÈRE ET LANCE UN MISSILE
EN DIRECTION DE DIESEL QUI EST À TERRE.



DIESEL IS HURT, BUT STILL STRONG ENOUGH TO
USE HIS BATTERING RAM TO SLAM INTO RAVAGE!
DIESEL EST BLESSÉ, MAIS SUFFISAMMENT FORT
ENCORE POUR SE PRÉCIPITER SUR RAVAGE ET LUI
RENTREZ DEDANS EN SE SERVANT DE SON BÉLIER !

US GB Read all instructions and warnings before you start to build and operate the models. Keep these instructions in a handy location. They contain important safety information.

F Lis tous les avertissements et les instructions avant de commencer le montage et l'exploitation du modèle. Garde ces instructions à portée de la main. Elles comportent d'importantes informations de sécurité.

NL Gelieve alle waarschuwingen en aanwijzingen te lezen vóór je het model begint op te bouwen en te gebruiken. Bewaar deze aanwijzingen op een gemakkelijk bereikbare plaats. Ze bevatten belangrijke veiligheidsgegevens.

US GB **WARNING:** This is a Class 1 LED product.

US **FCC Statements:**

This device complies with Part 15 of the FCC rules. Operation is subject to the following two conditions:

1. This device may not cause harmful interference and
2. This device must accept any interference received including interference that may cause undesired operation.

This model is tested to comply with FCC standards - FOR HOME AND OFFICE USE.

FCC Statement:

This equipment has been tested and found to comply with the limits for a Class B digital device, pursuant to part 15 of the FCC rules. These limits were designed to provide reasonable protection against harmful interference in a residential installation. This equipment generates, uses, and can radiate radio frequency energy, and, if not installed and used in accordance with the instructions, may cause harmful interference to radio communications. However, there is no guarantee that interference will not occur in a particular installation. If this equipment does cause harmful interference to radio or television reception, which can be determined by turning the equipment off and on, the user is encouraged to try to correct the interference by one or more of the following measures: (1) Reorient or relocate the receiving antenna. (2) Increase the separation between the equipment and receiver. (3) Consult the dealer or an experienced radio/TV technician.

F **AVERTISSEMENT :** ce produit est un produit de Classe 1 LED.

NL **WAARSCHUWING:** dit is een klasse 1 LED-product.

US GB The light module comes with 3 button cell batteries already installed.

F Le module lumière vient avec 3 piles déjà installées.

NL De lichtmodule wordt met 3 reeds geïnstalleerde batterijen geleverd.

US GB **WARNING:** As with all small items, these batteries should be kept away from children. If swallowed, seek medical attention immediately.

F **AVERTISSEMENT :** comme avec tous les petits objets, ces piles doivent être tenues hors de la portée des enfants. En cas d'ingestion, appeler immédiatement un médecin ou l'hôpital.

NL **WAARSCHUWING:** Zoals het geval is met alle kleine onderwerpen, moeten deze kleine batterijen verwijderd blijven van kinderen. Ingeval van inslikken, kijk onmiddellijk uit naar medische verzorging.

US GB To replace batteries, remove the screw as shown. Insert 3 button cell (or LR44, A76 or SR44) batteries, matching the (+/-) diagram inside the compartment.

F Pour remettre les piles, retirer la vis comme l'indique le schéma. Installer 3 piles boutons LR44 (A76 ou SR44), en suivant le diagramme (+/-) gravé à l'intérieur du boîtier.

NL Verwijder de schroef zoals afgebeeld om de batterijen te vervangen. Steek er 3 LR44 (A76 of SR44) batterijen in, en doe ze overeenstemmen met het (+/-) diagram binnenin het compartiment.



US GB Caution:
Do not aim missiles at eyes or face. Never aim missiles at others or pets. Never attempt to launch any projectiles other than the K'NEX missiles.

F **MISE EN GARDE** : ne vise pas les yeux ou le visage avec les missiles. Ne vise jamais des personnes ou des animaux domestiques avec les missiles. Ne tente jamais de lancer des projectiles autres que les missiles K'NEX.

NL **OPGEPAST**: Geen missielen naar de ogen of het gezicht mikken. Nooit de missielen nooit naar anderen toe of naar geen dieren. Tracht nooit projectielen af te vuren die geen projectielen van K'NEX zijn.

US GB Light is activated by inserting a Rod in the hole in the top of the head.

F L'indicatif lumineux est activé en introduisant une tige dans l'orifice situé dans la partie supérieure de la tête.

NL Het licht wordt aangezet door een staafje te steken in het gaatje bovenaan het hoofd.



US GB Light doesn't work? Check to see if you have fresh button cell batteries and that they are installed properly.

F Le son et/ou la lumière ne marche pas ? Vérifie si les piles sont chargées et si elles sont bien installées.

NL Werkt het geluid en/of licht niet? Ga even na of de batterijen geladen zijn en of ze goed op hun plaats zitten.

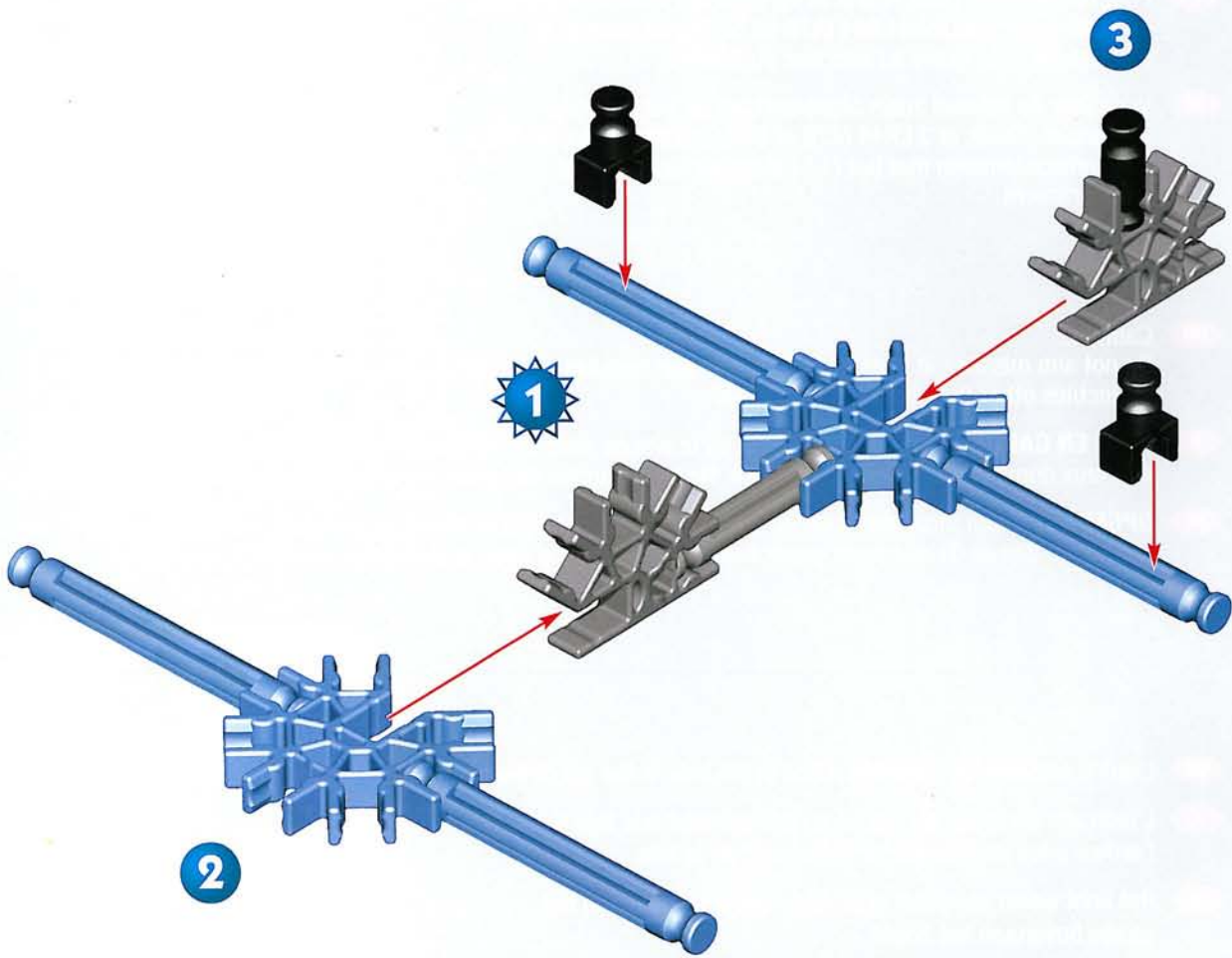

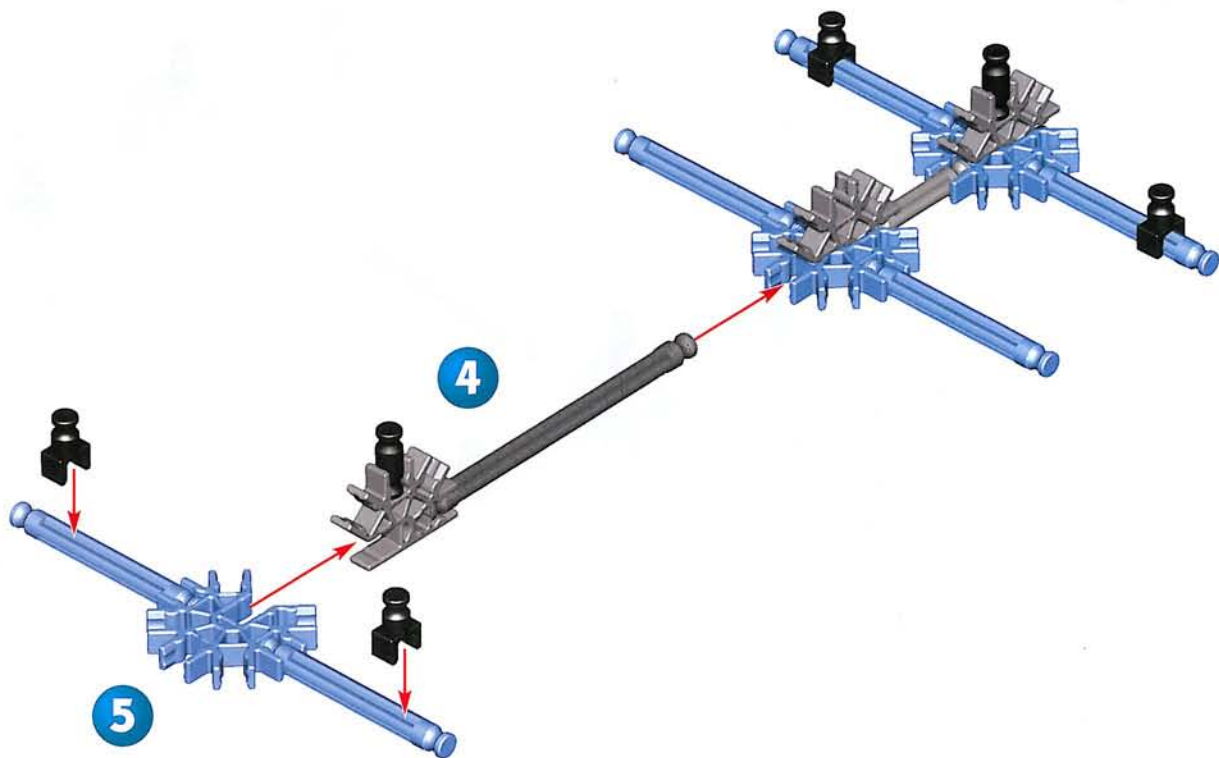

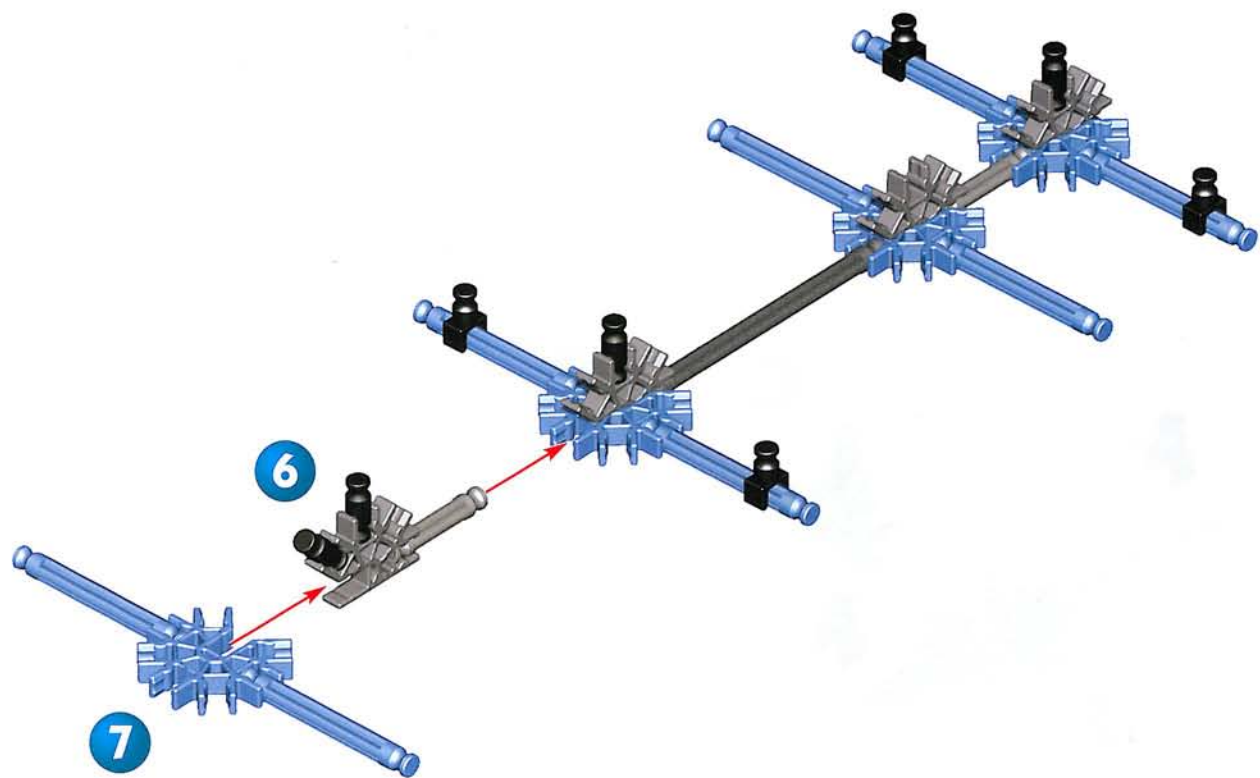

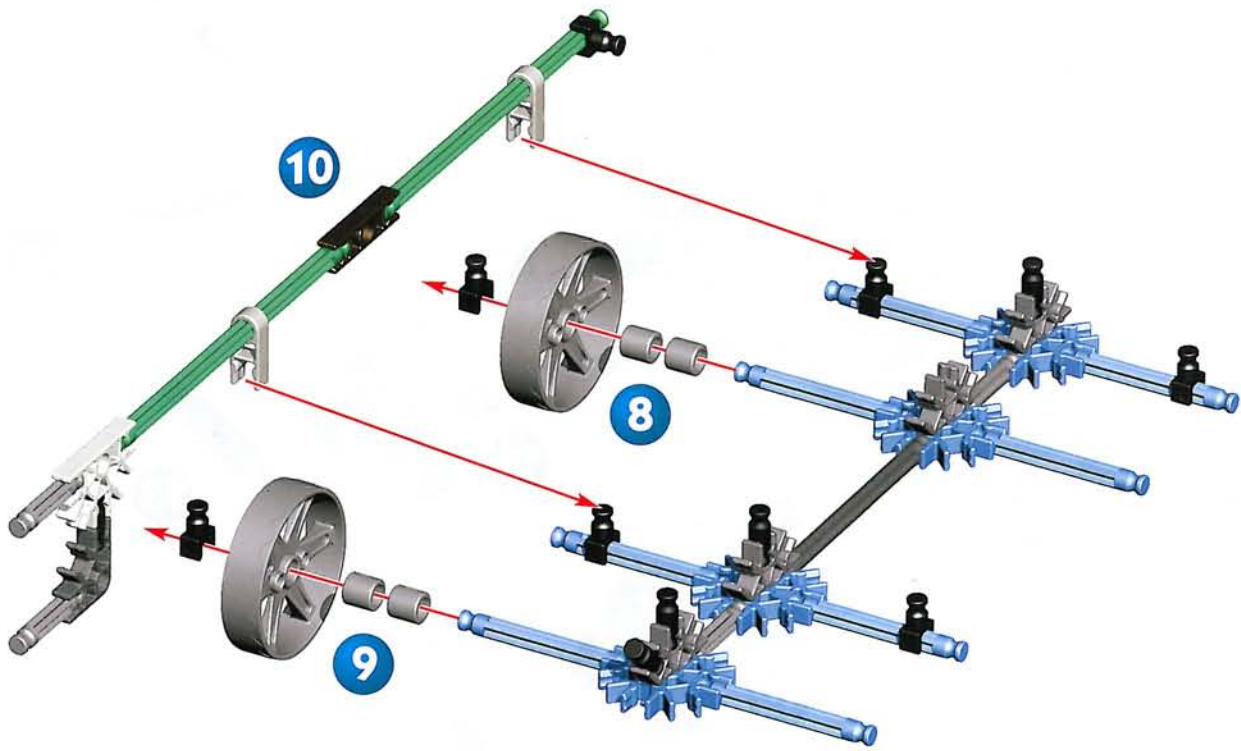

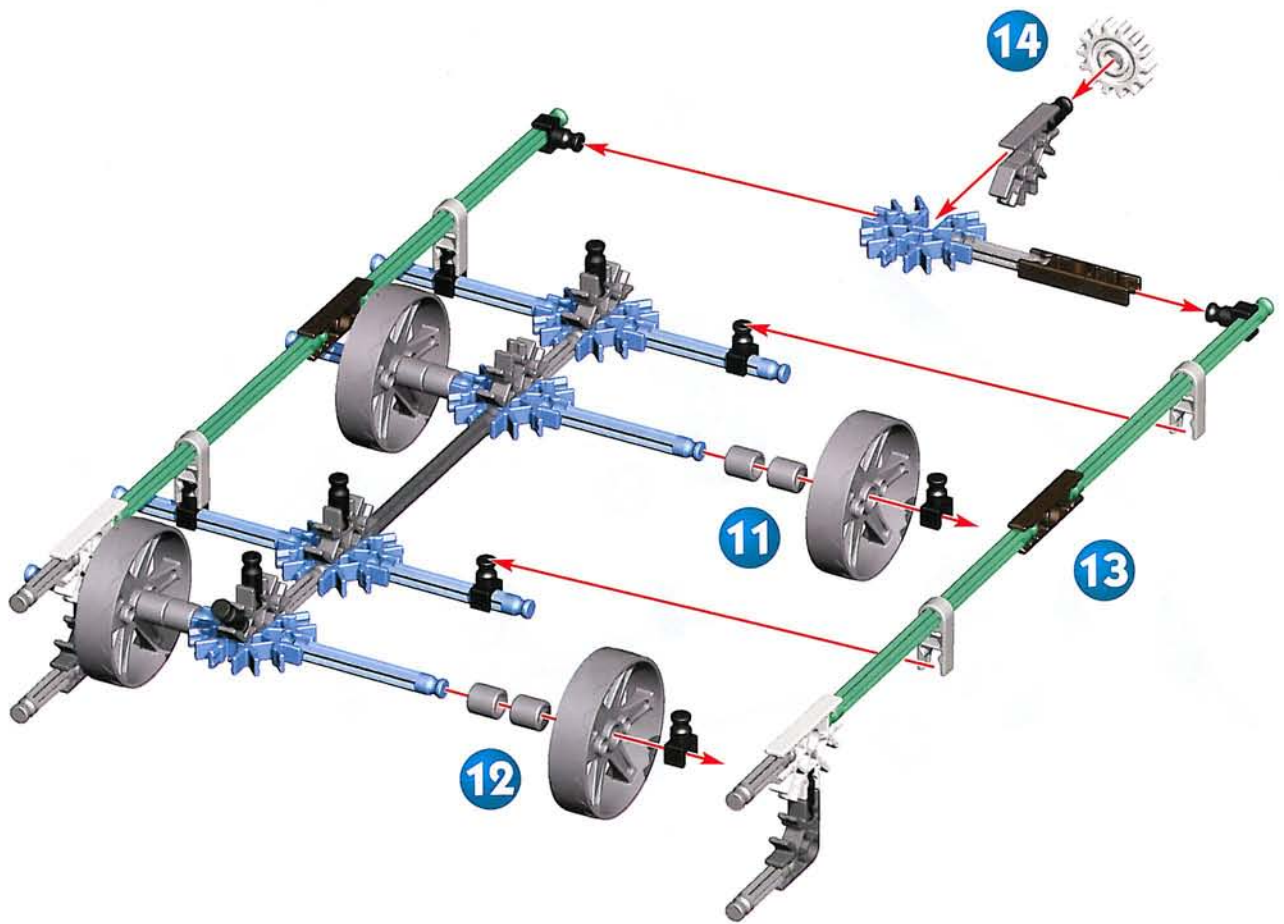

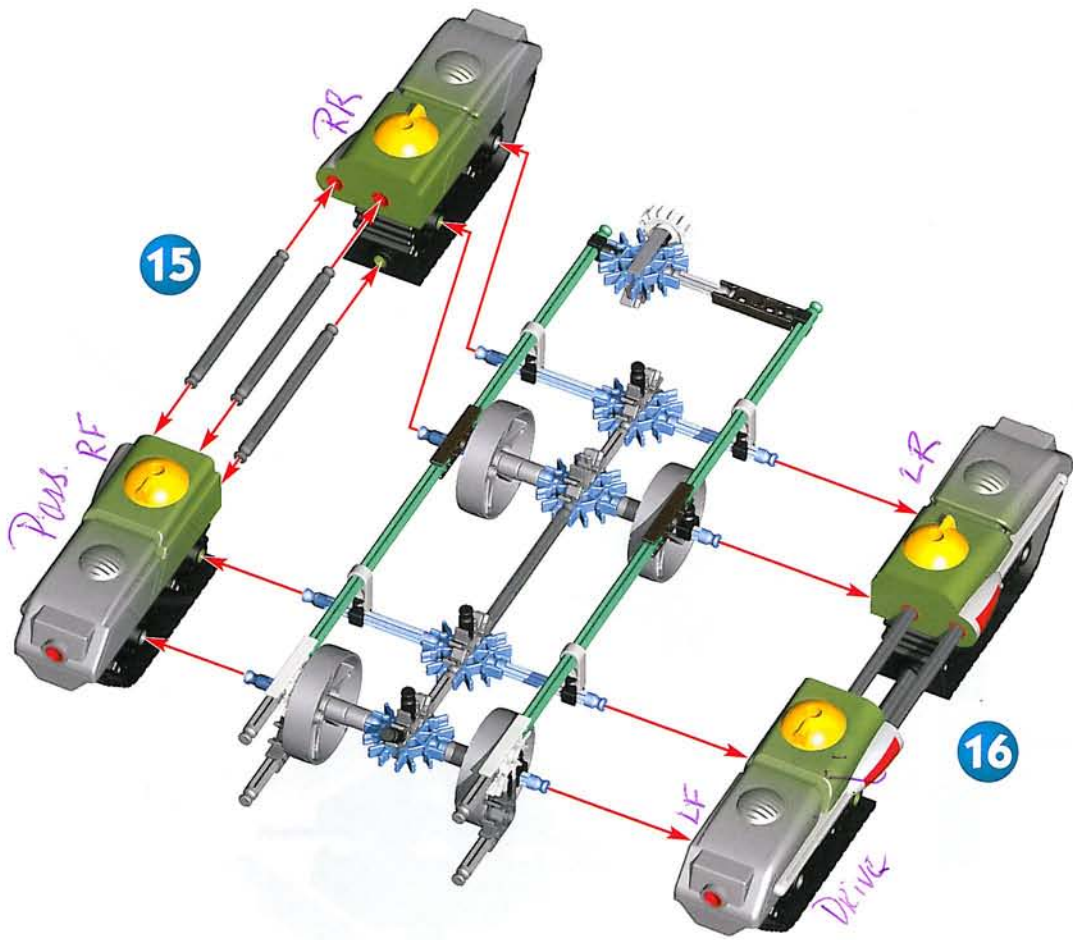

15

16

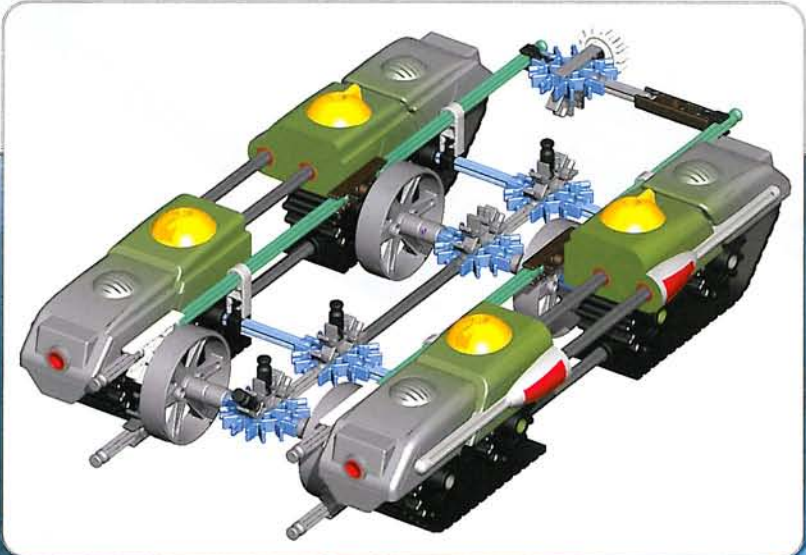

- US GB Here's what you've already built.
- F Voilà ce que tu as déjà construit.
- NL Kijk even wat je reeds hebt opgebouwd.

US GB Build this section separately (steps 17 - 22).

F Construis cette section séparément (étapes 17 - 22).

NL Dit gedeelte afzonderlijk opbouwen (stappen 17 - 22).

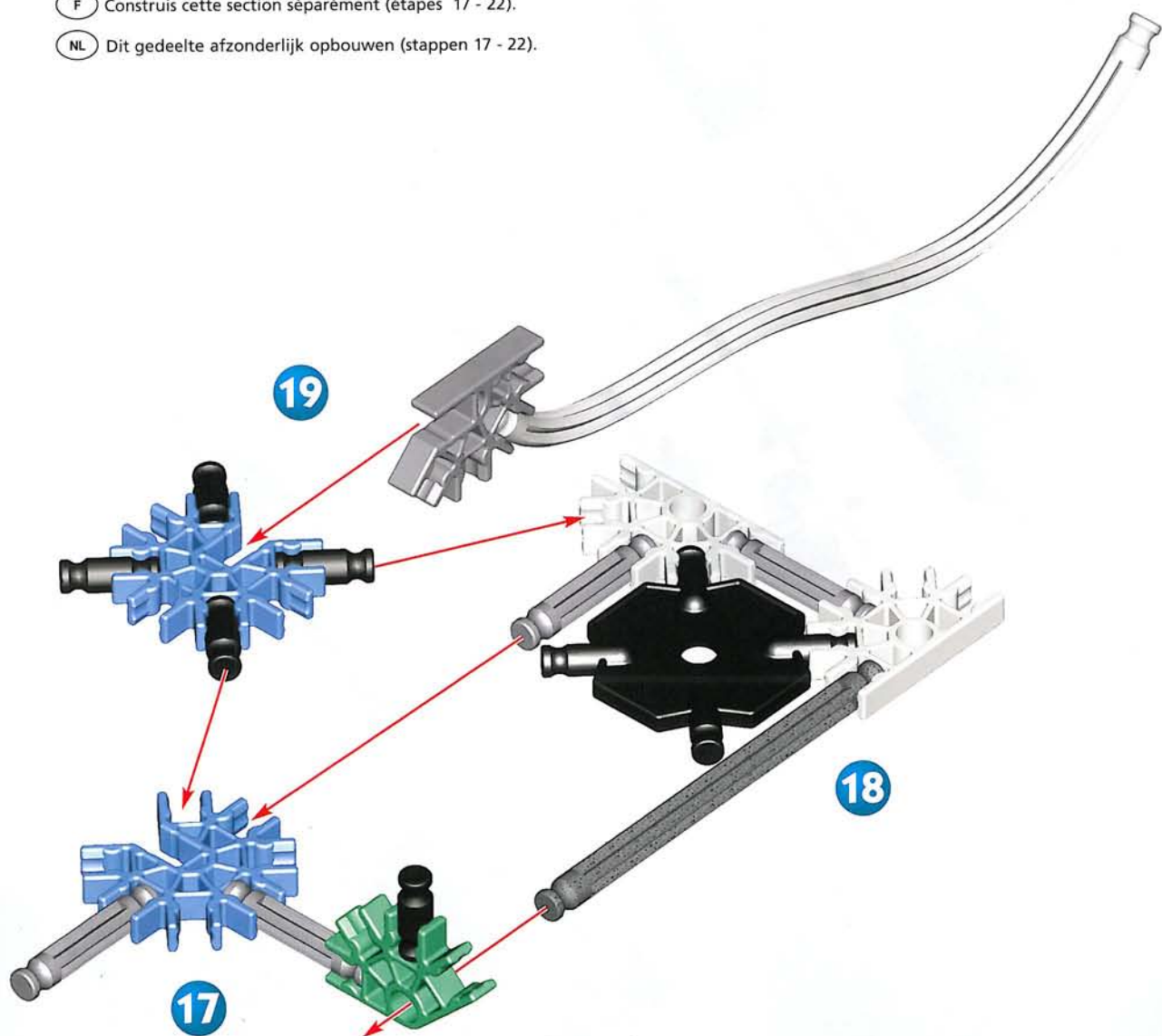

20

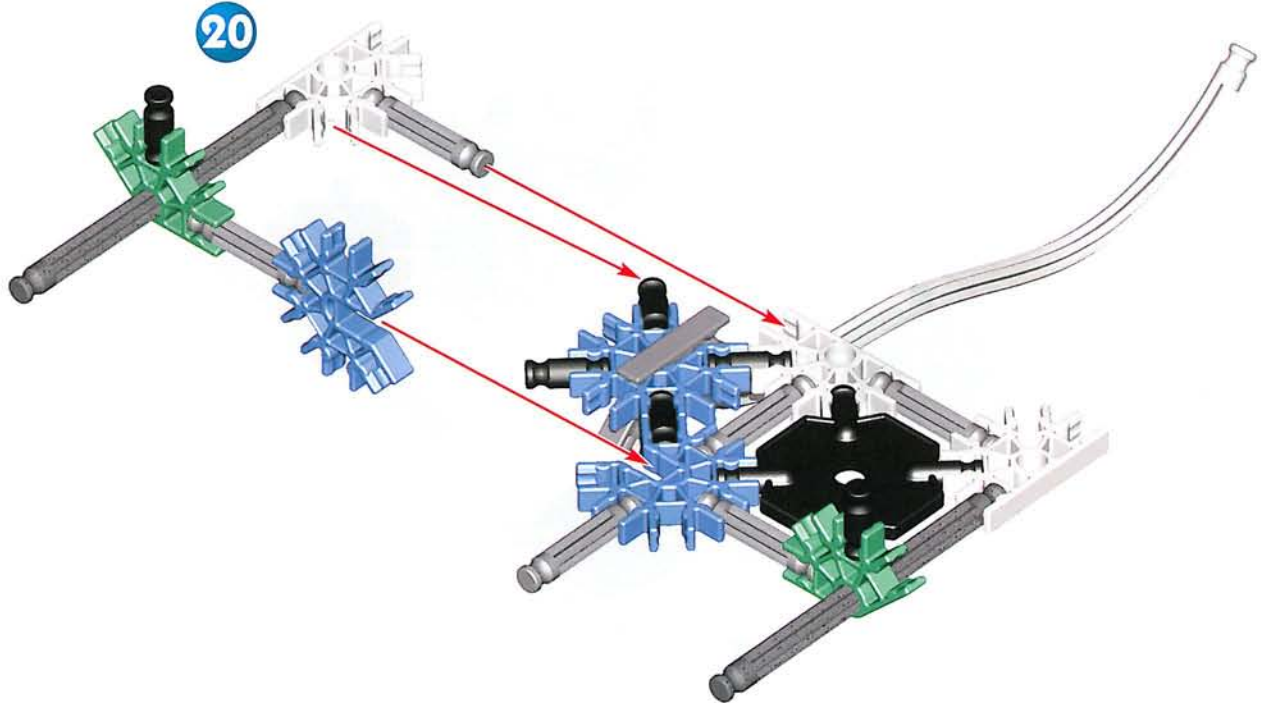

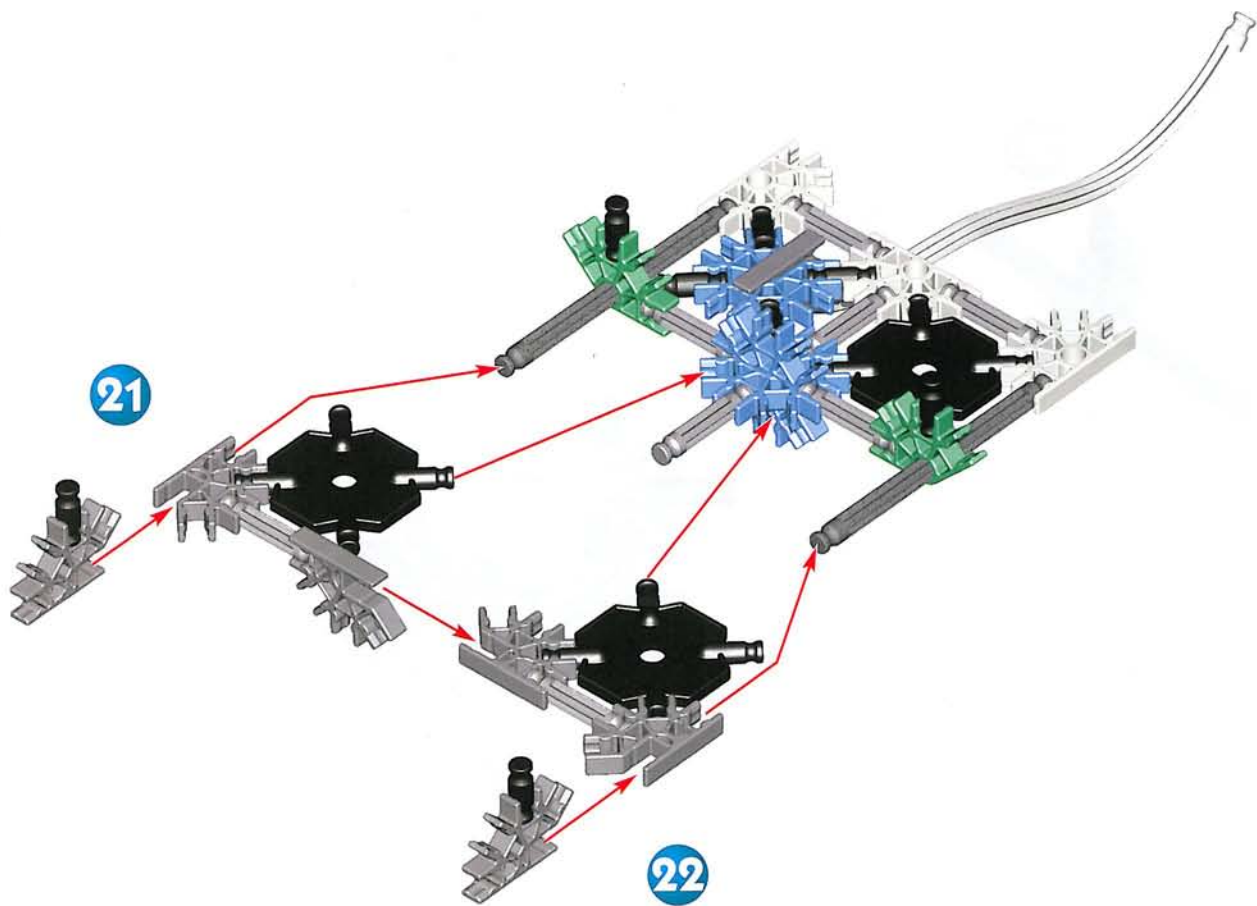

US GB Now attach it to the model.

F Fixe-la maintenant au modèle.

NL Het nu aan het model vastmaken.

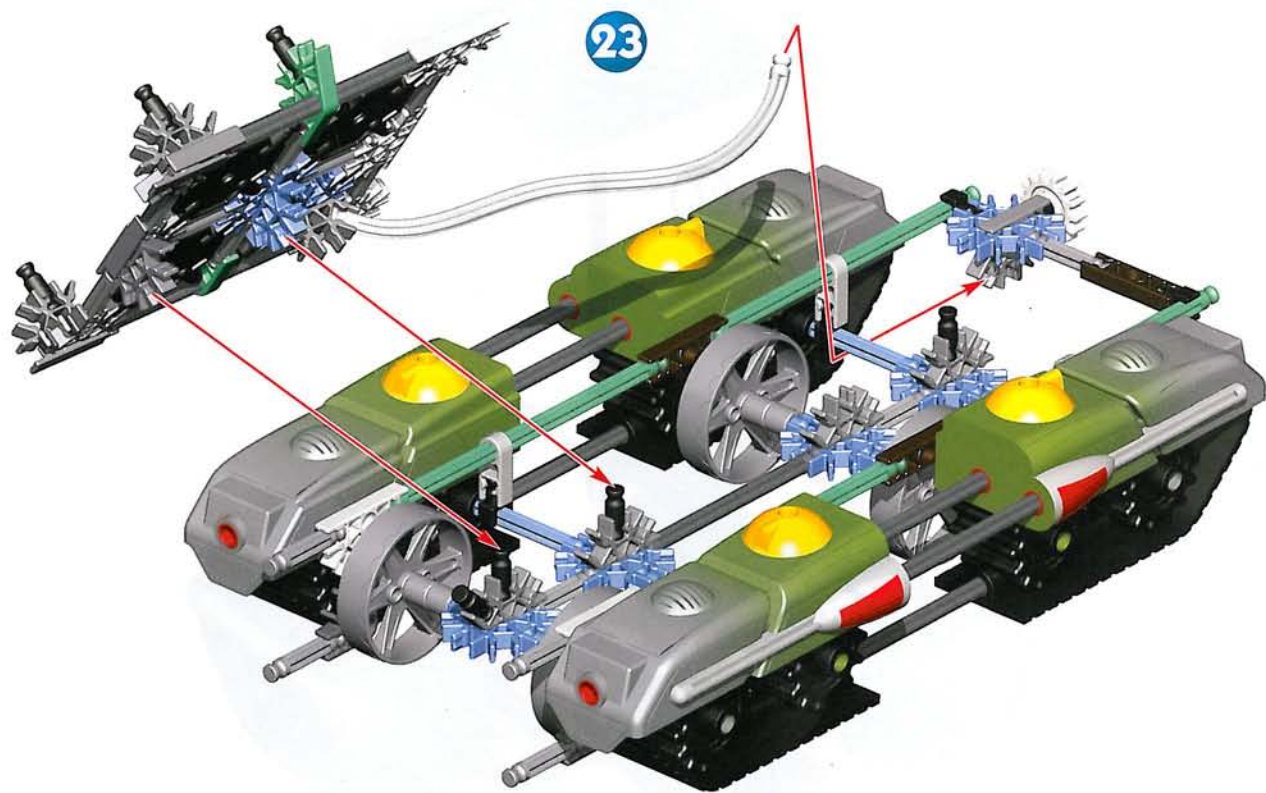



26

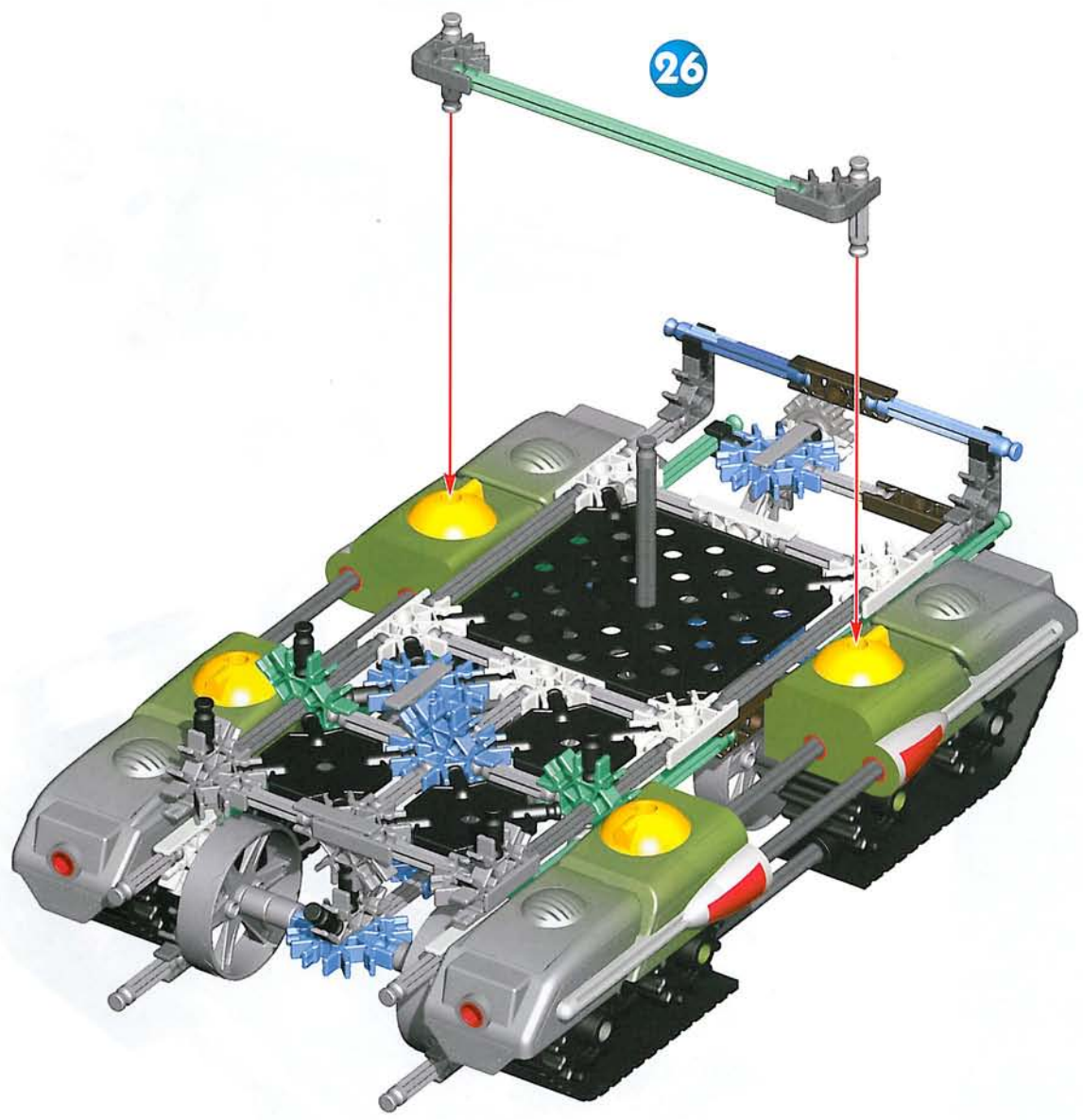

27

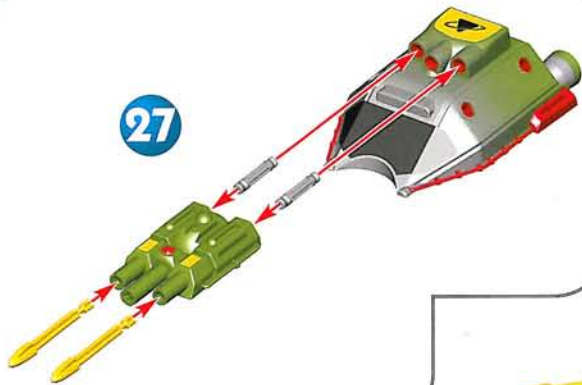

29

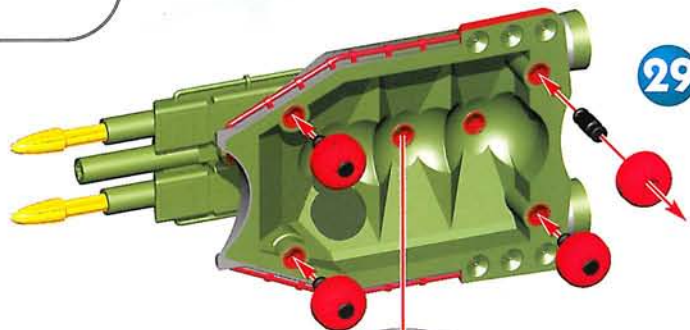

28

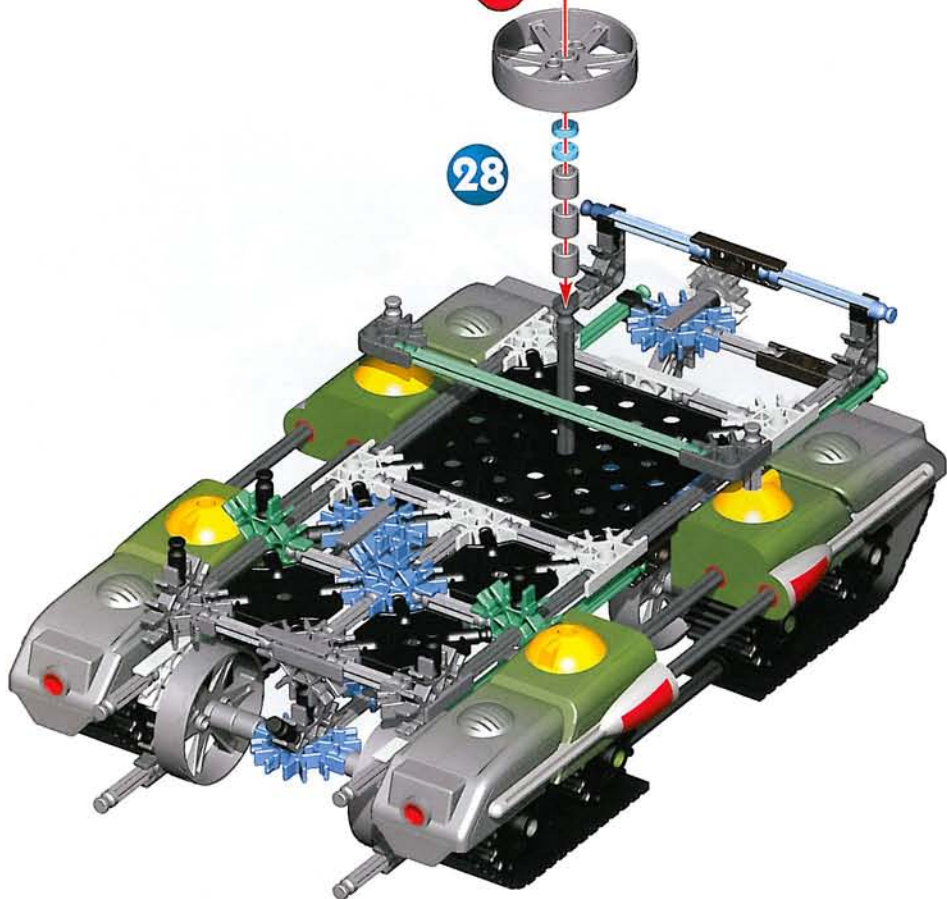

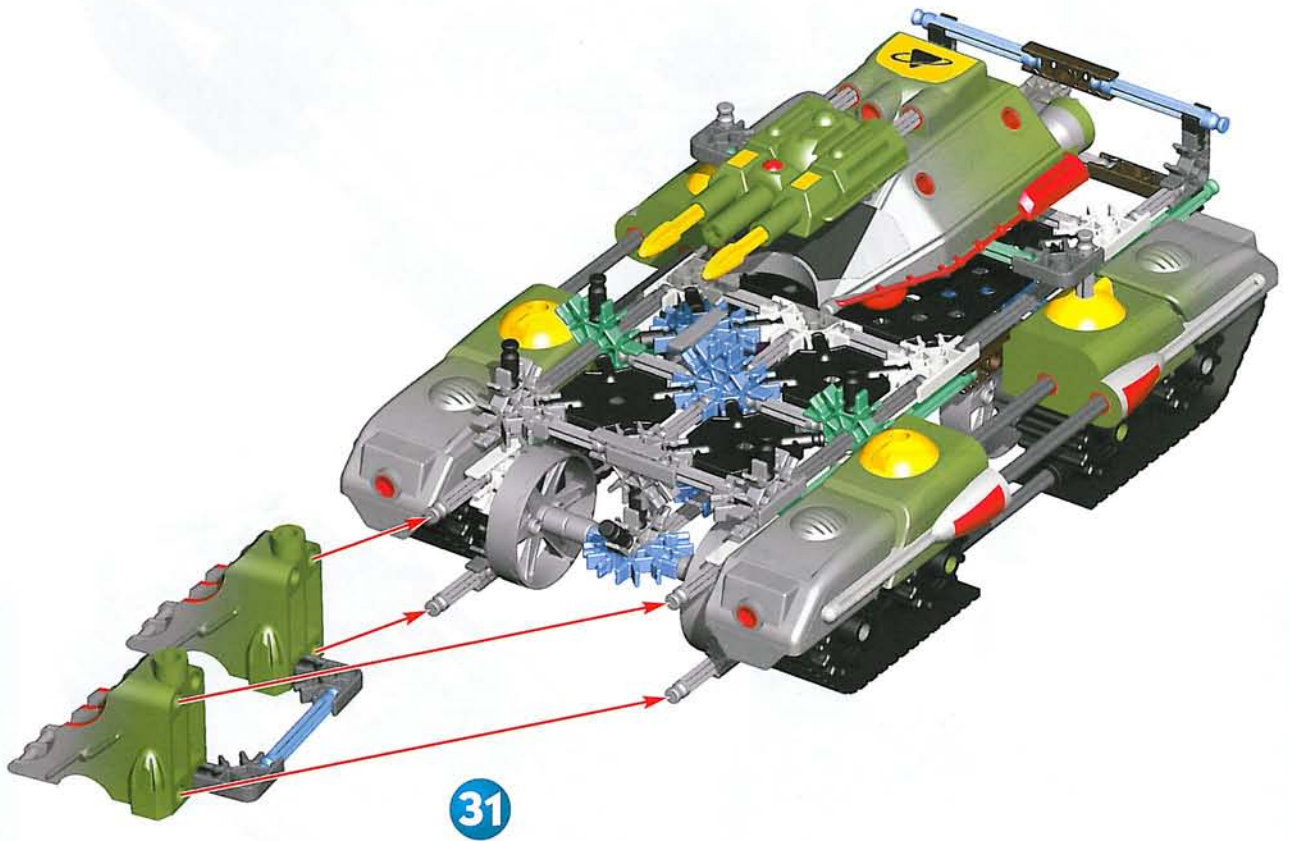
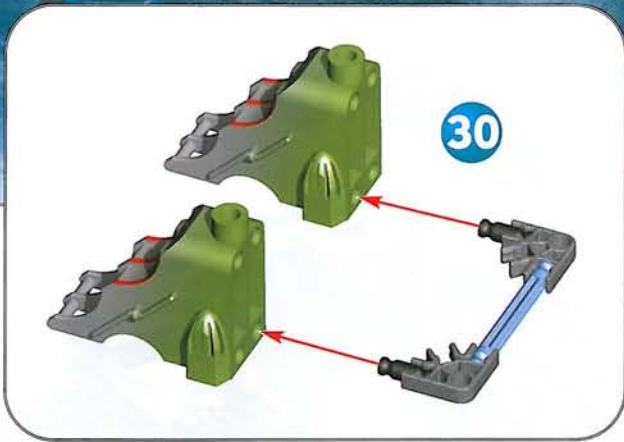

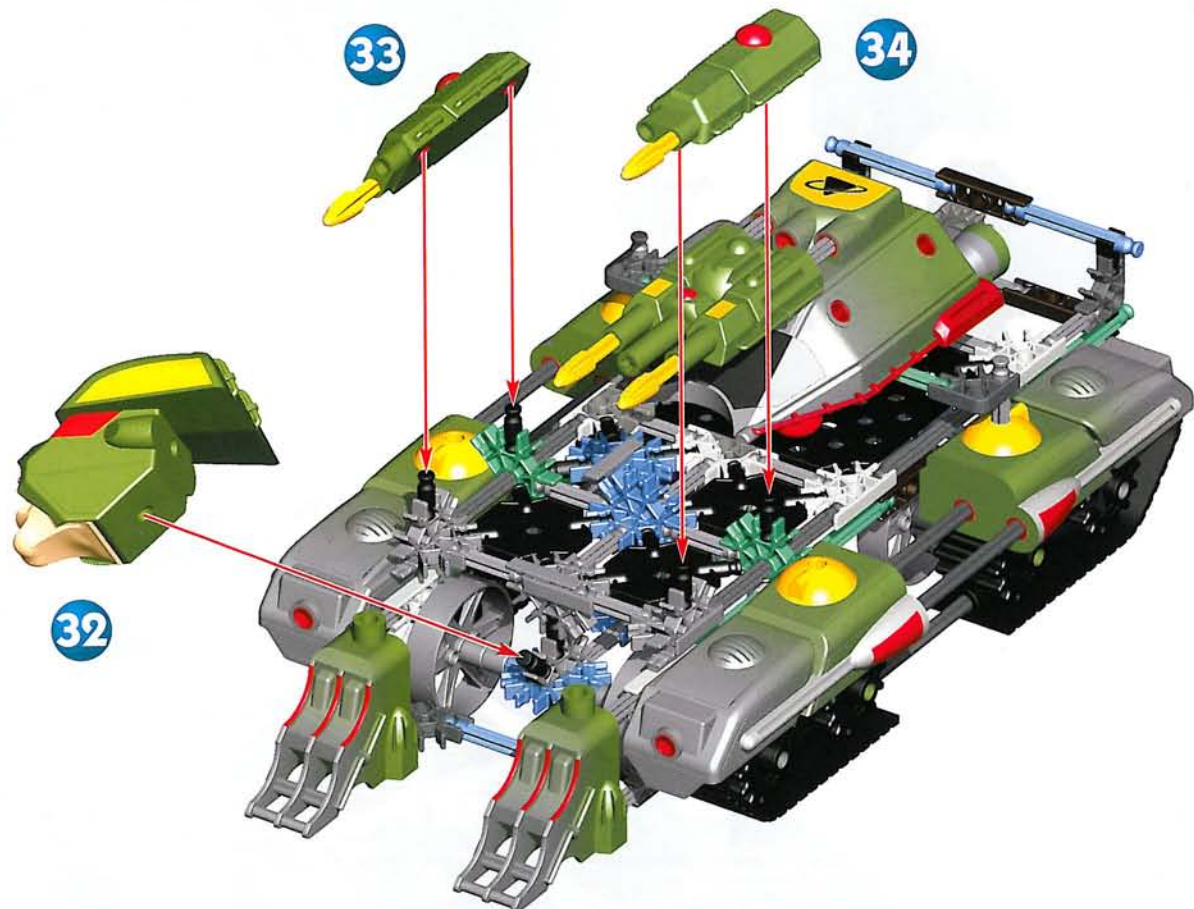

DIESEL FIRES ANOTHER MISSILE AT RAVAGE AND NOTICES THAT RAVAGE ALWAYS GUARDS THE SAME SPOT ON HIS HEAD!
DIESEL LANCE UN AUTRE MISSILE EN DIRECTION DE RAVAGE, ET REMARQUE QUE RAVAGE PROTÈGE TOUJOURS LE MÊME ENDROIT SUR SA TÊTE !



DIESEL YELLS "ReKconstruct"
AND CHANGES INTO BATTLE MODE!
DIESEL CRIE « REKONSTRUCT ! »
ET PASSE EN MODE DE GUERRIER !



RAVAGE ALSO CHANGES INTO HIS BATTLE SHAPE,
AND THE BATTLE BEGINS!
RAVAGE SE TRANSFORME EN GUERRIER,
ET LA BATAILLE COMMENCE !



DIESEL REMOVES
RAVAGE'S POWERCORE.
DIESEL S'EMPRE DU
POWERCORE
DE RAVAGE

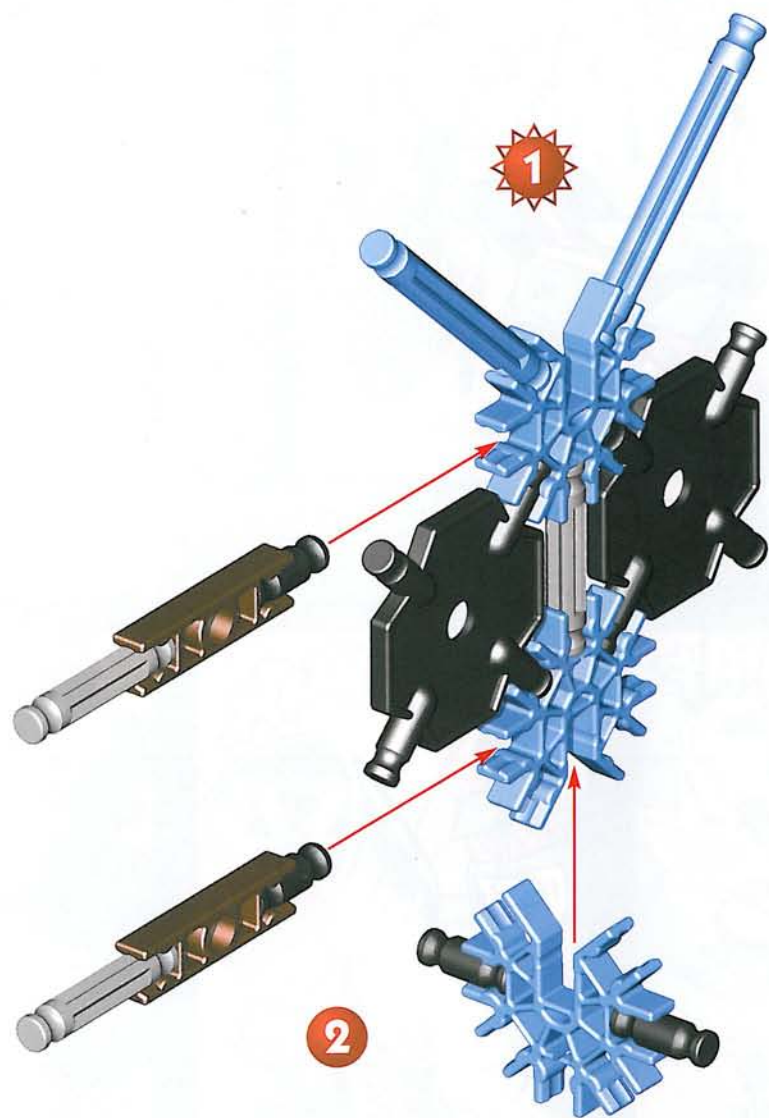

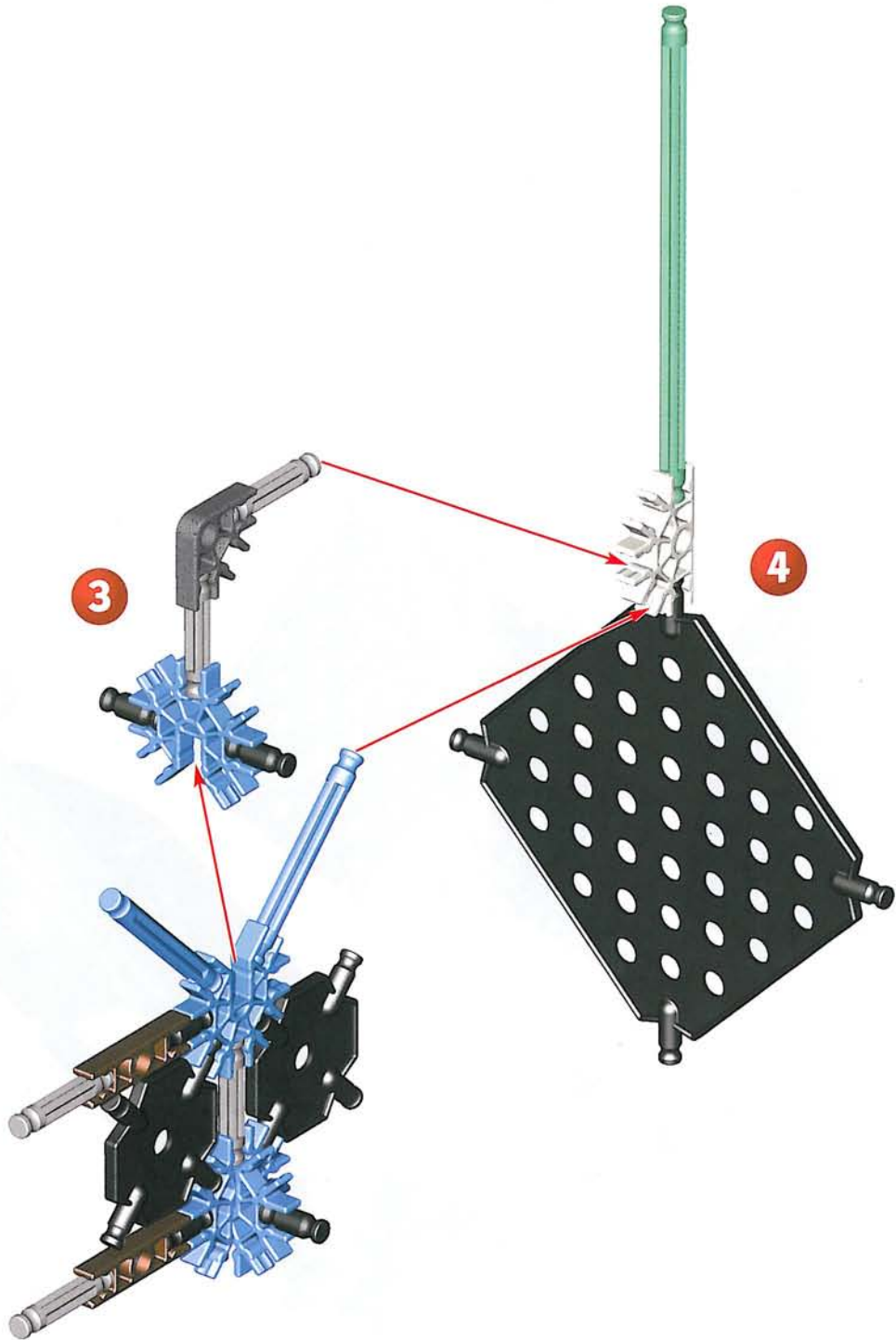

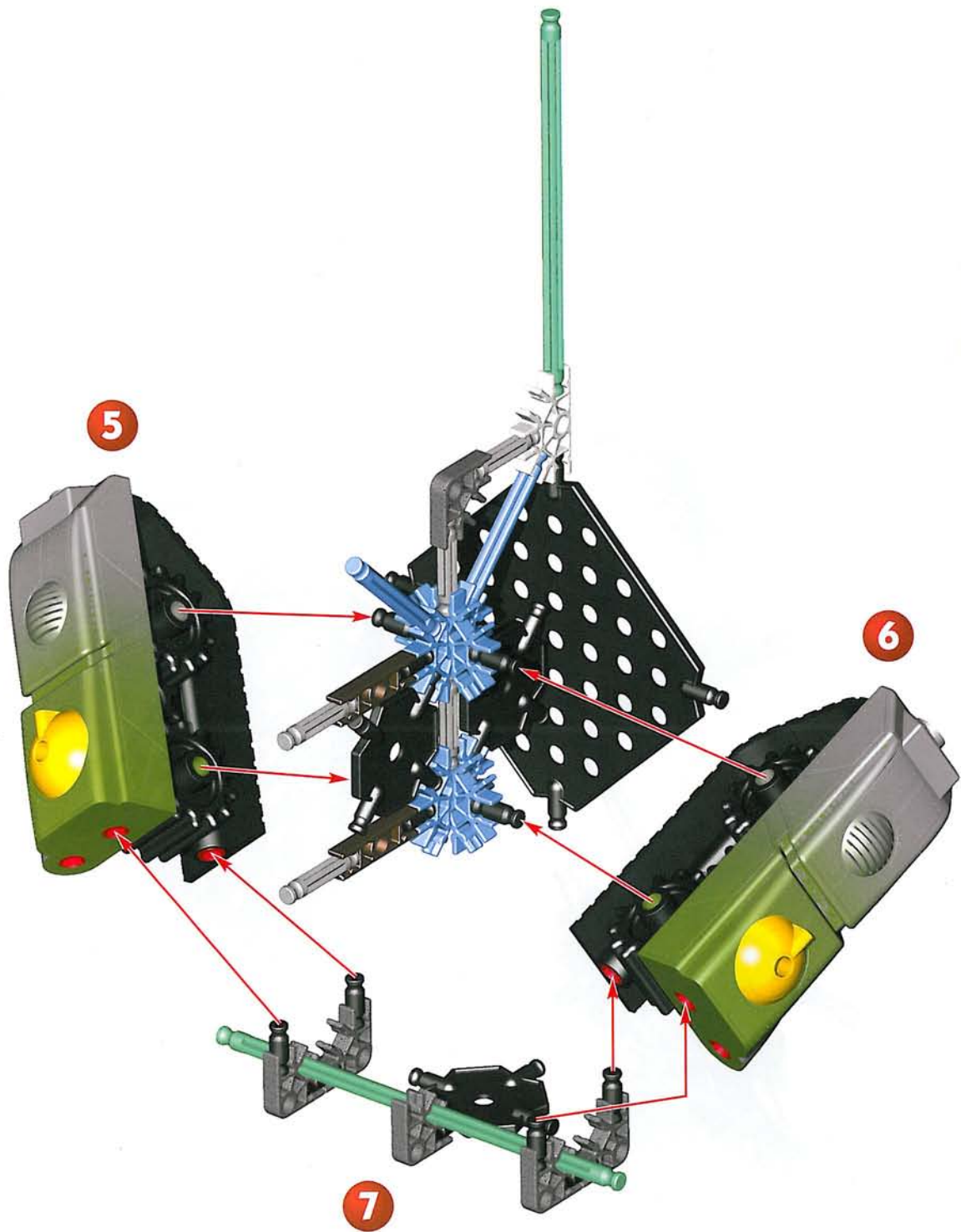

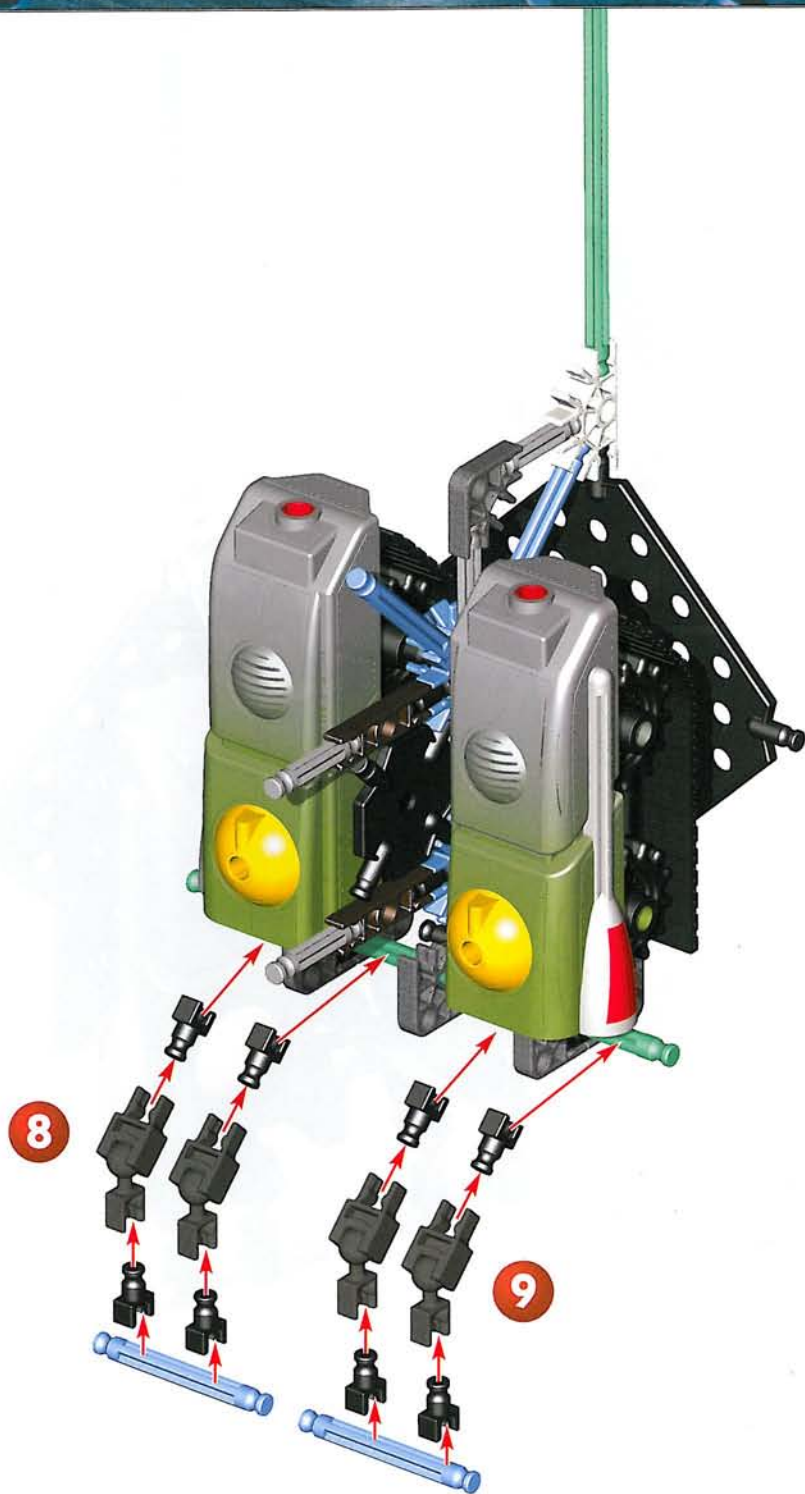

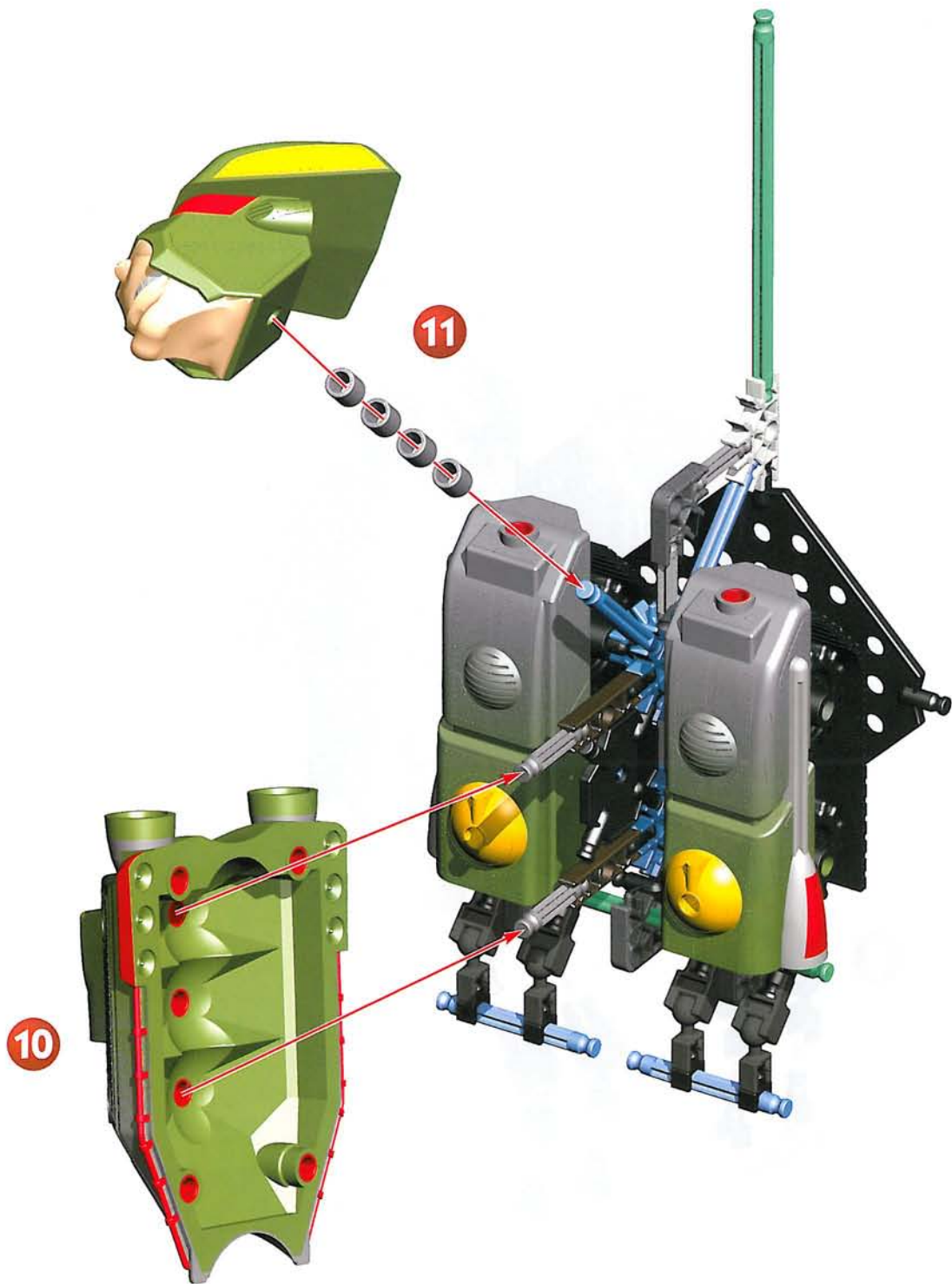



12

13

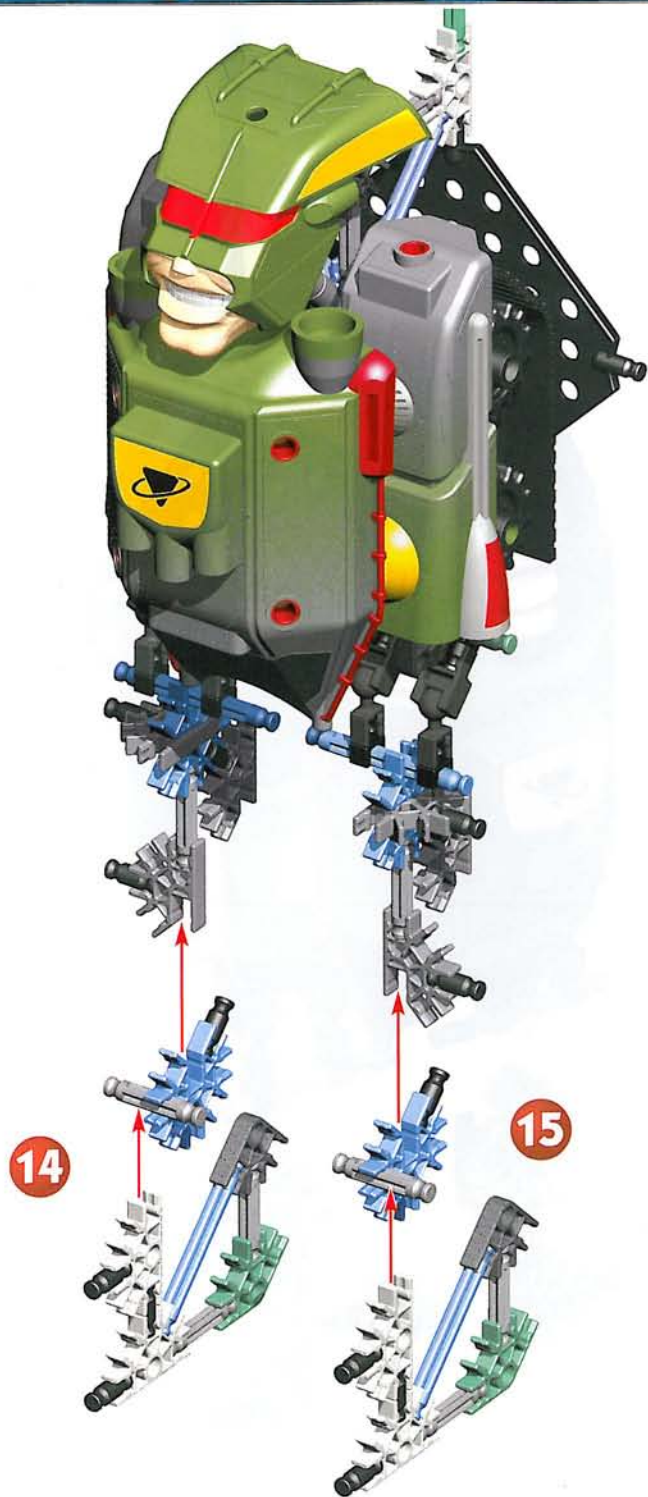

14

15

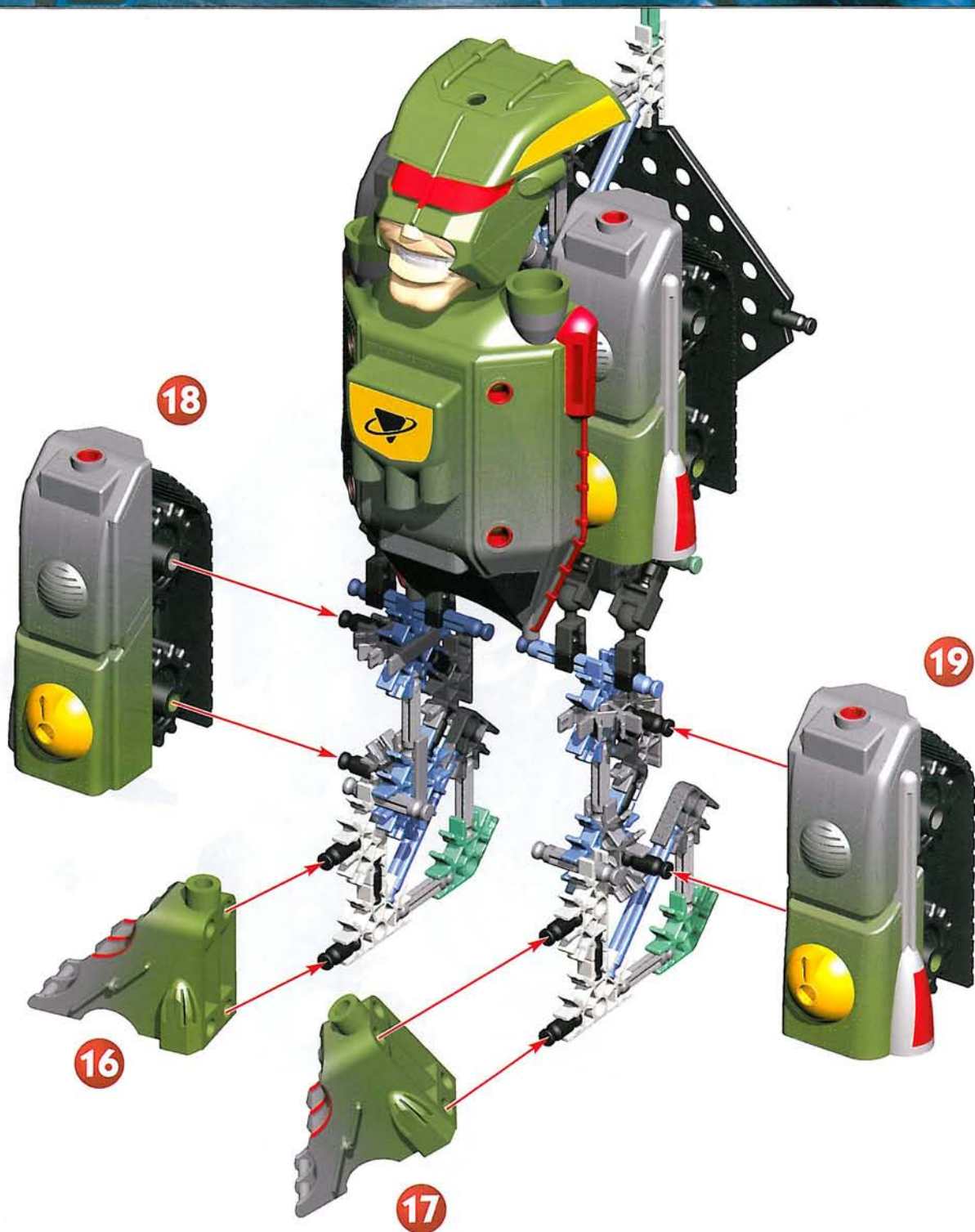

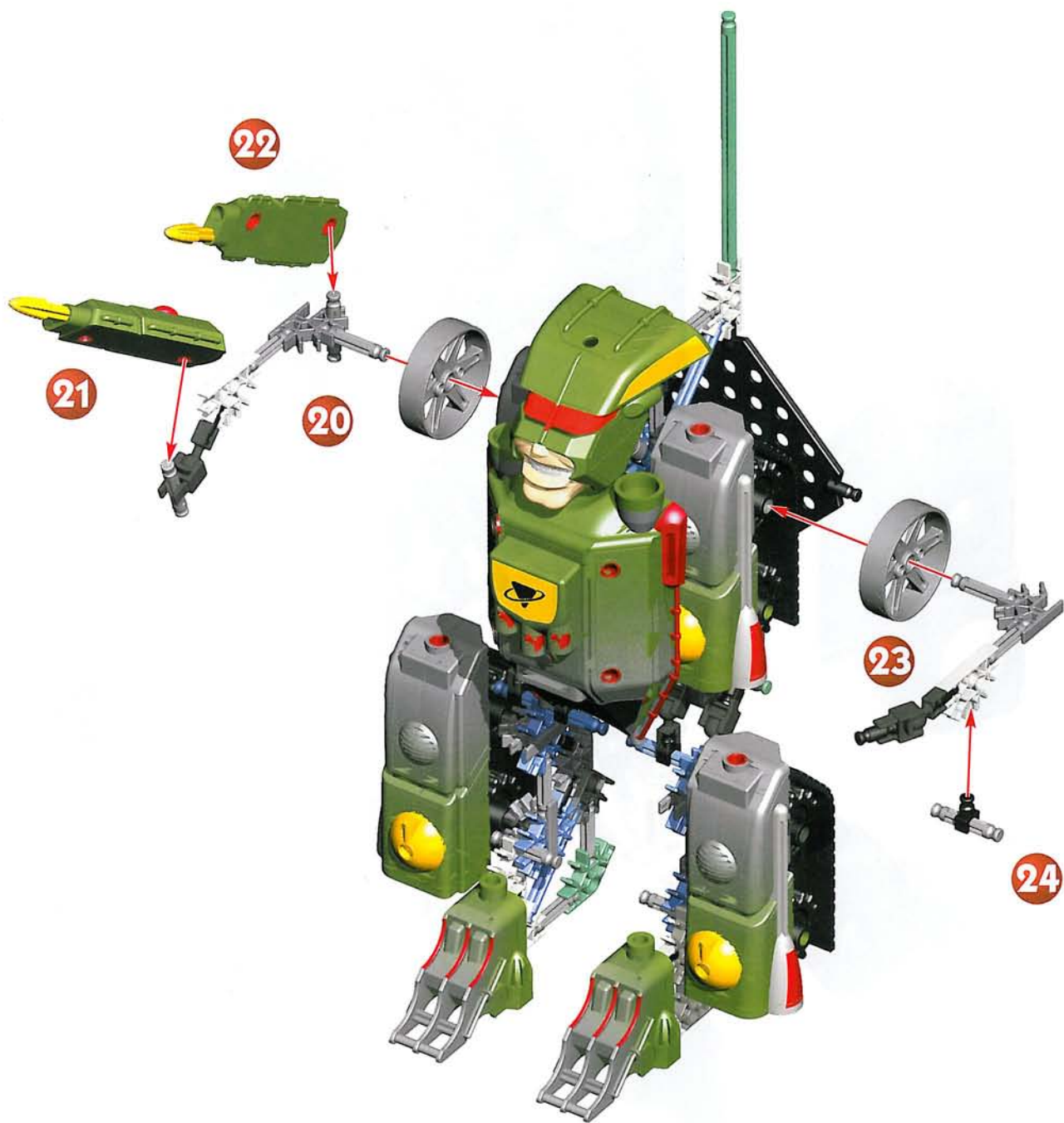







DIESEL WATCHES AS RAVAGE'S TEAMMATES
RETREAT, DEFEATED.
DIESEL OBSERVE TANDIS QUE LES COÉQUIPIERS
DE RAVAGE BATTENT EN RETRAITE, VAINCUS.



"ReKconstruct!"



DIESEL REKONSTRUCTS INTO HIS
MOBILE FIELD BASE MODE.
DIESEL PASSE EN MODE DE
CHAMP MOBILE.



DIESEL HELPS REPAIR HIS INJURED BUT VICTORIOUS ALLIES!
DIESEL AIDE À RÉPARER SES ALLIÉS QUI SONT
BLESSÉS MAIS VICTORIEUX!

"REST UP, EVERYONE! I HAVE A
FEELING THE BATTLE'S JUST BEGUN!"
REPOSEZ-VOUS, TOUT LE MONDE!
J'AI L'IMPRESSON QUE LA BATAILLE VIENT
TOUT JUSTE DE COMMENCER!

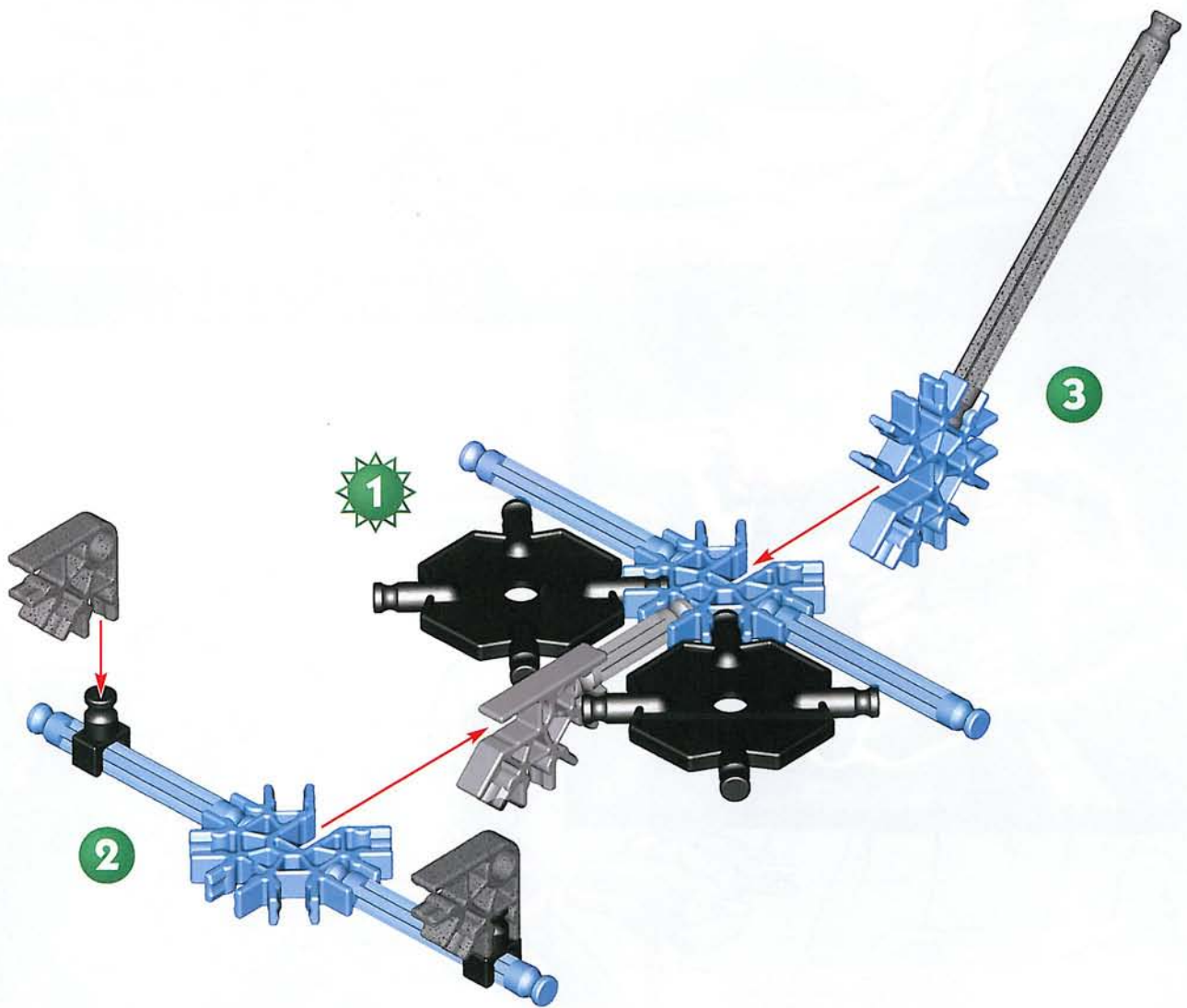

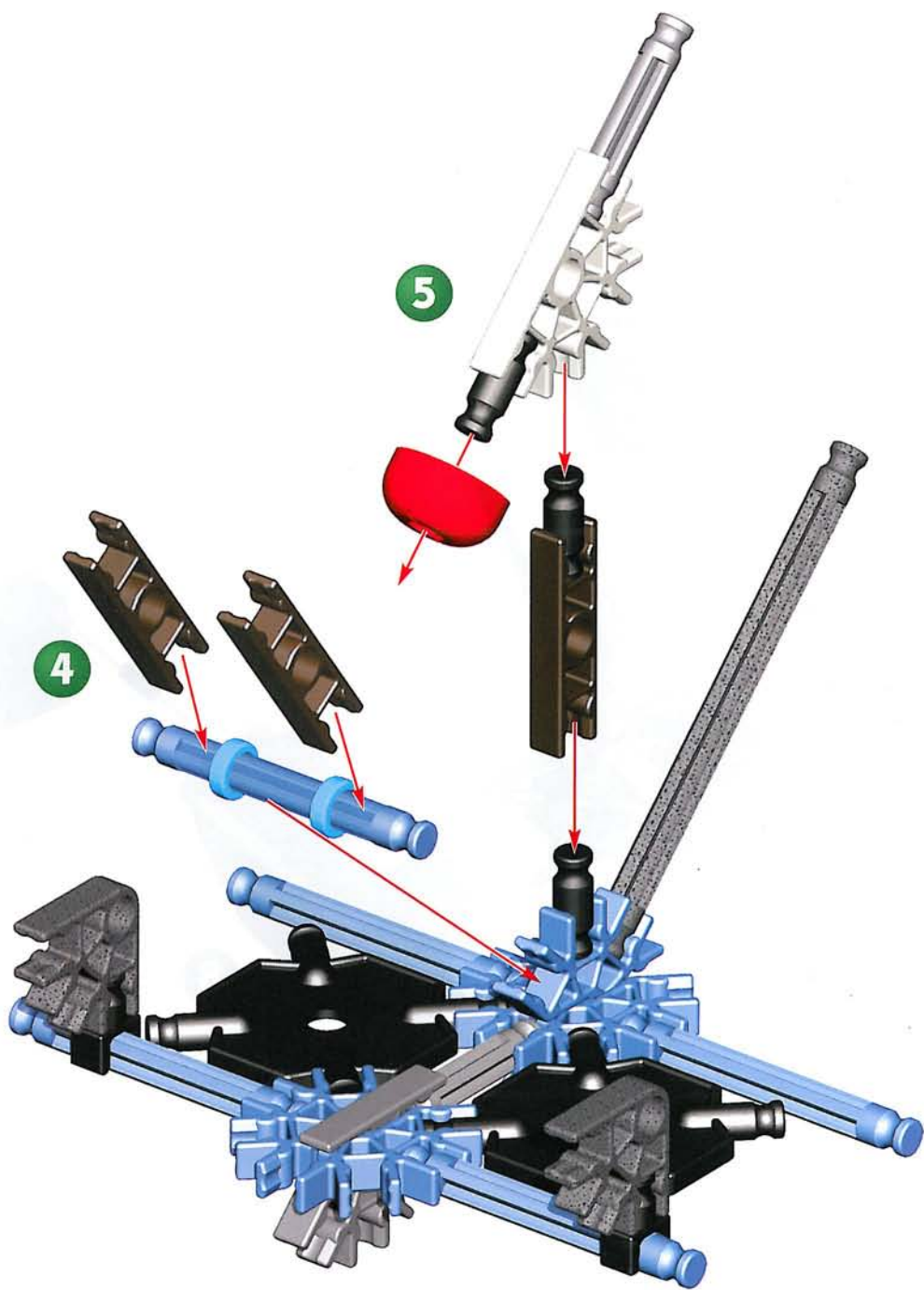

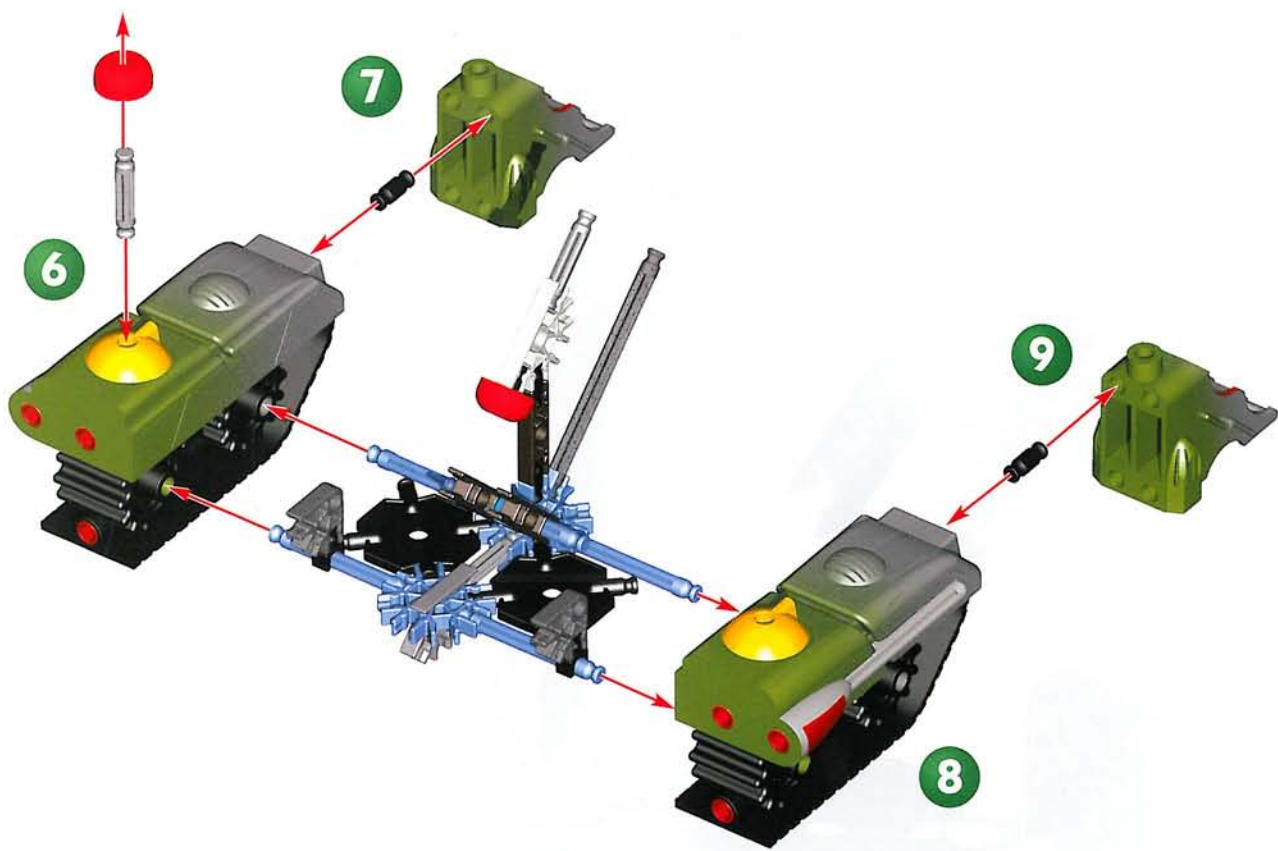

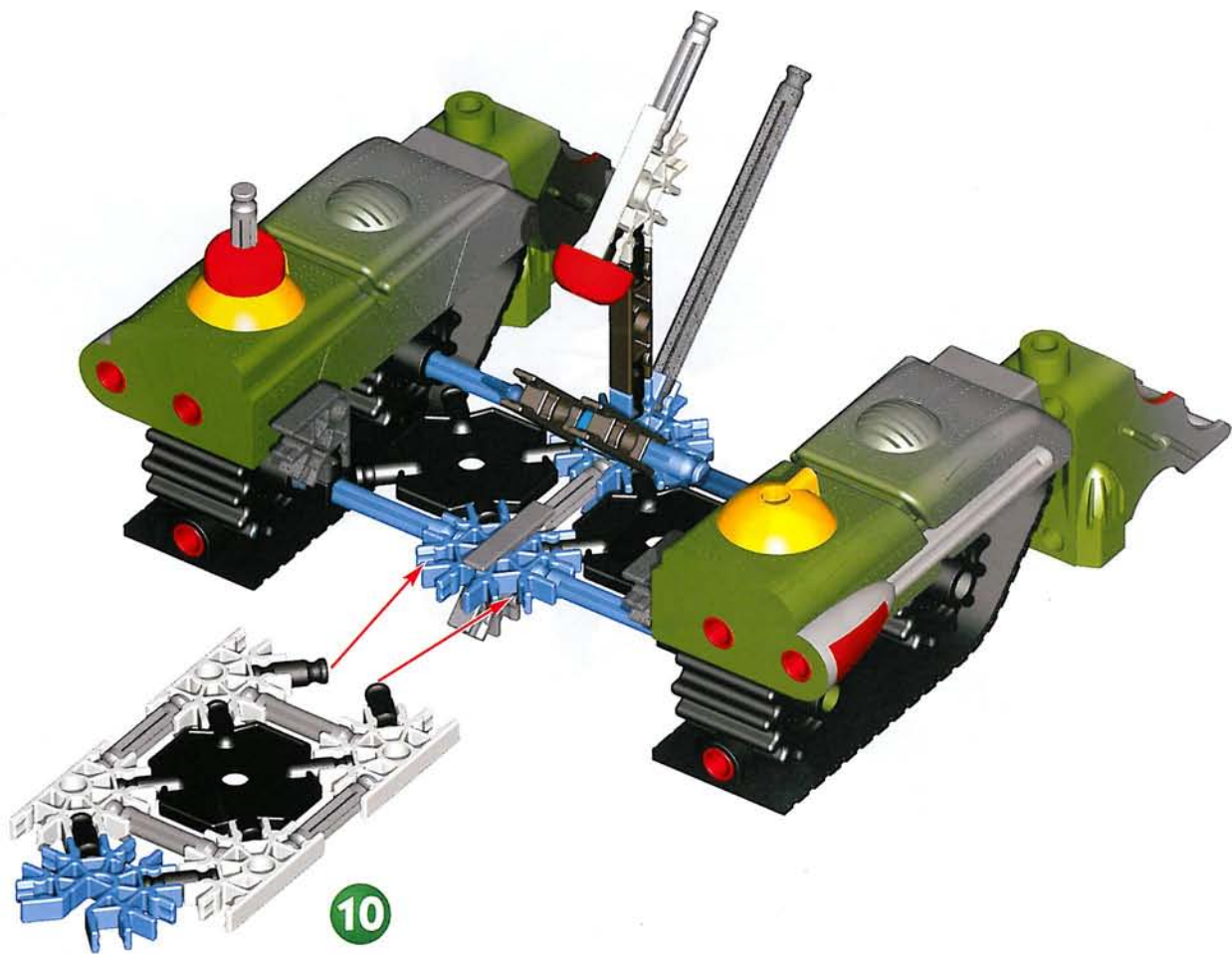

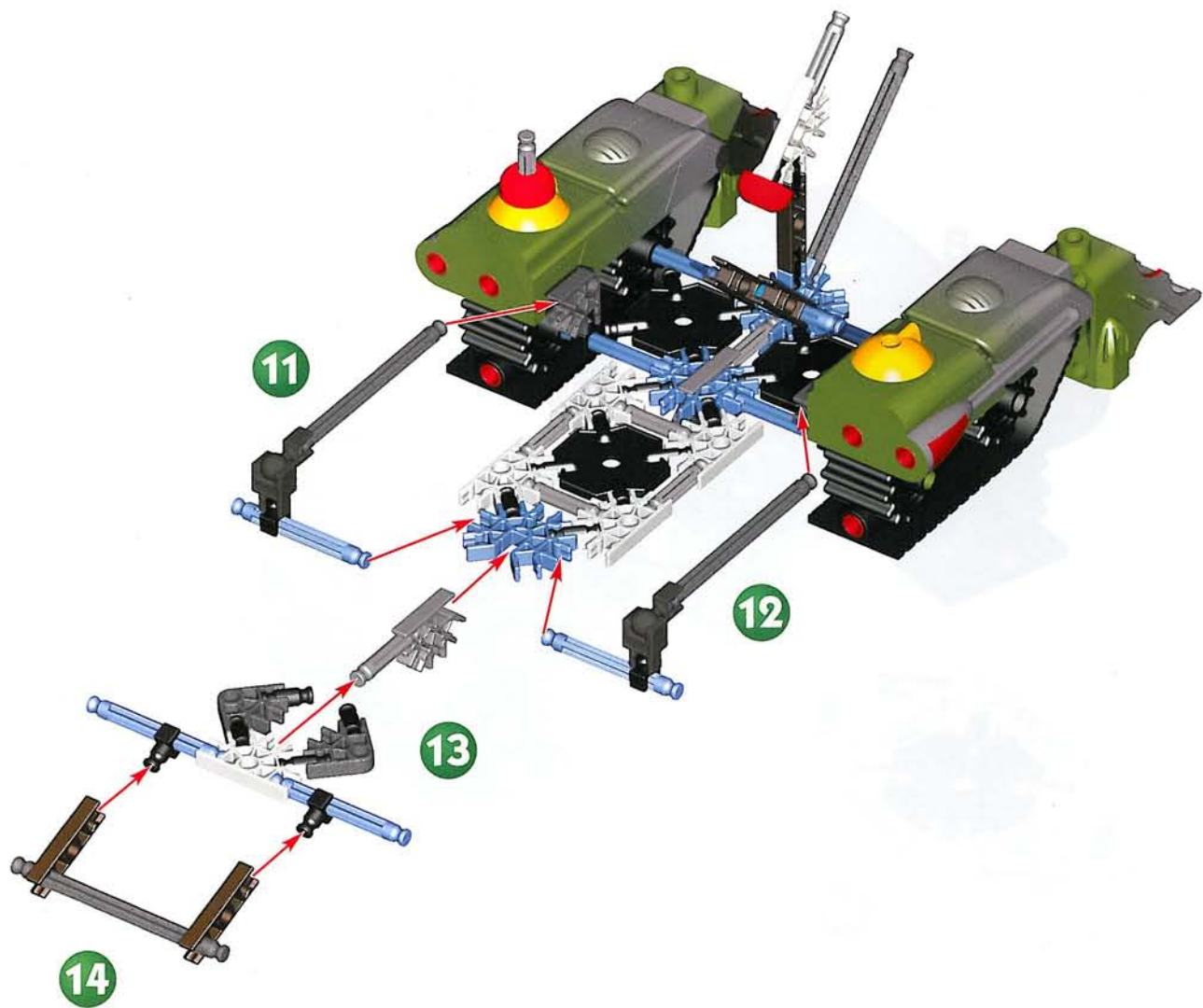

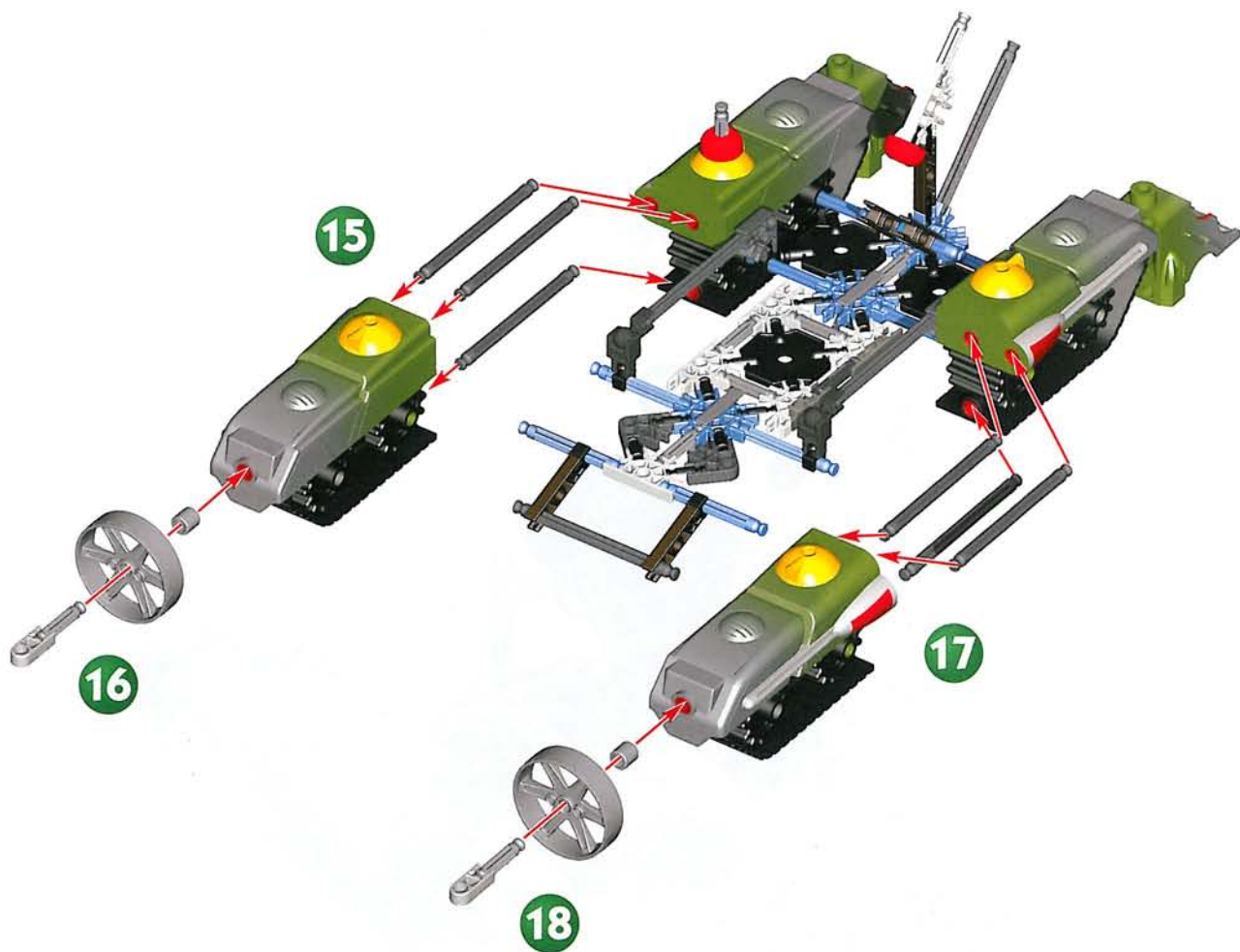

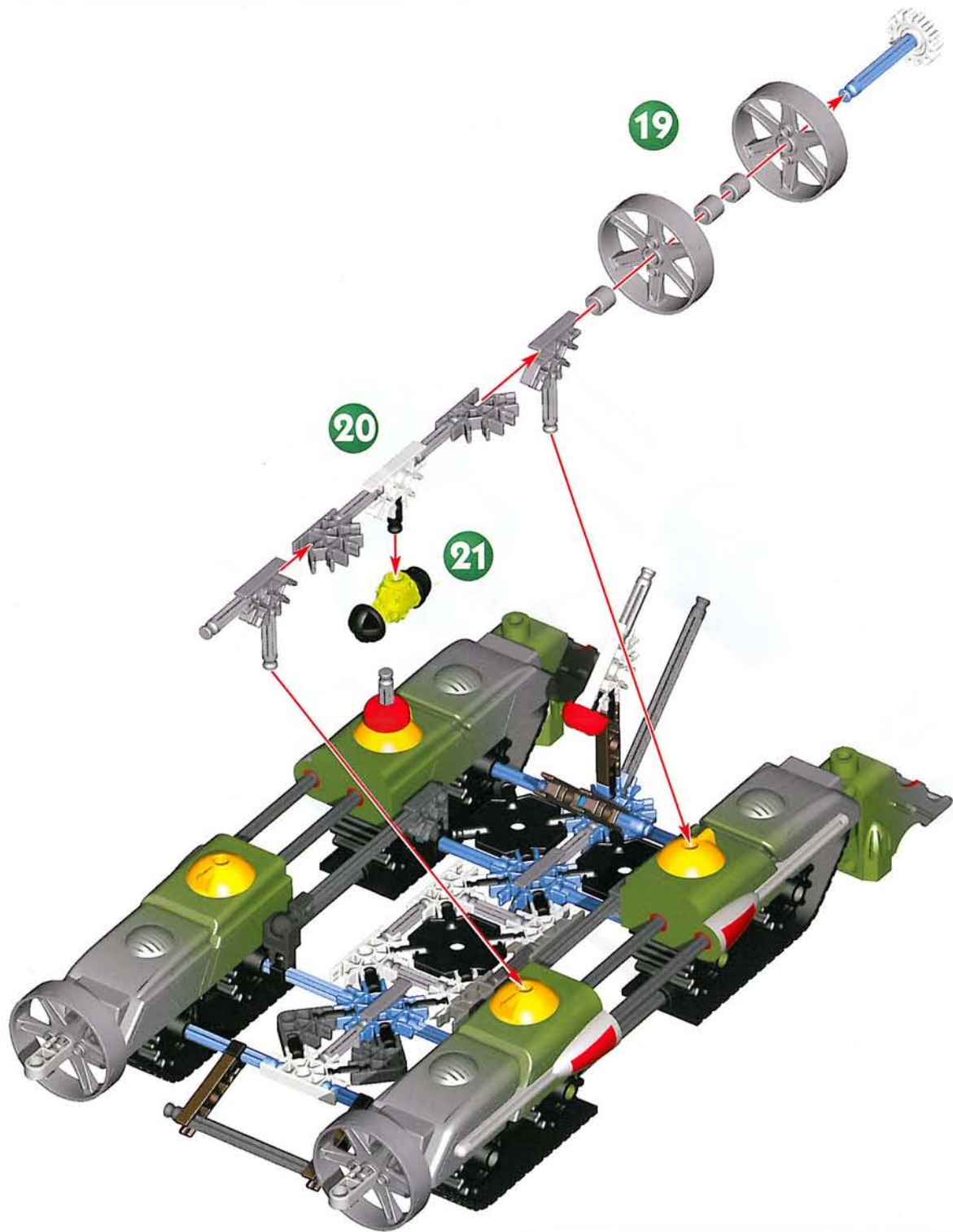

US GB Build this section separately.

F Construis cette section séparément.

NL Dit gedeelte afzonderlijk opbouwen.

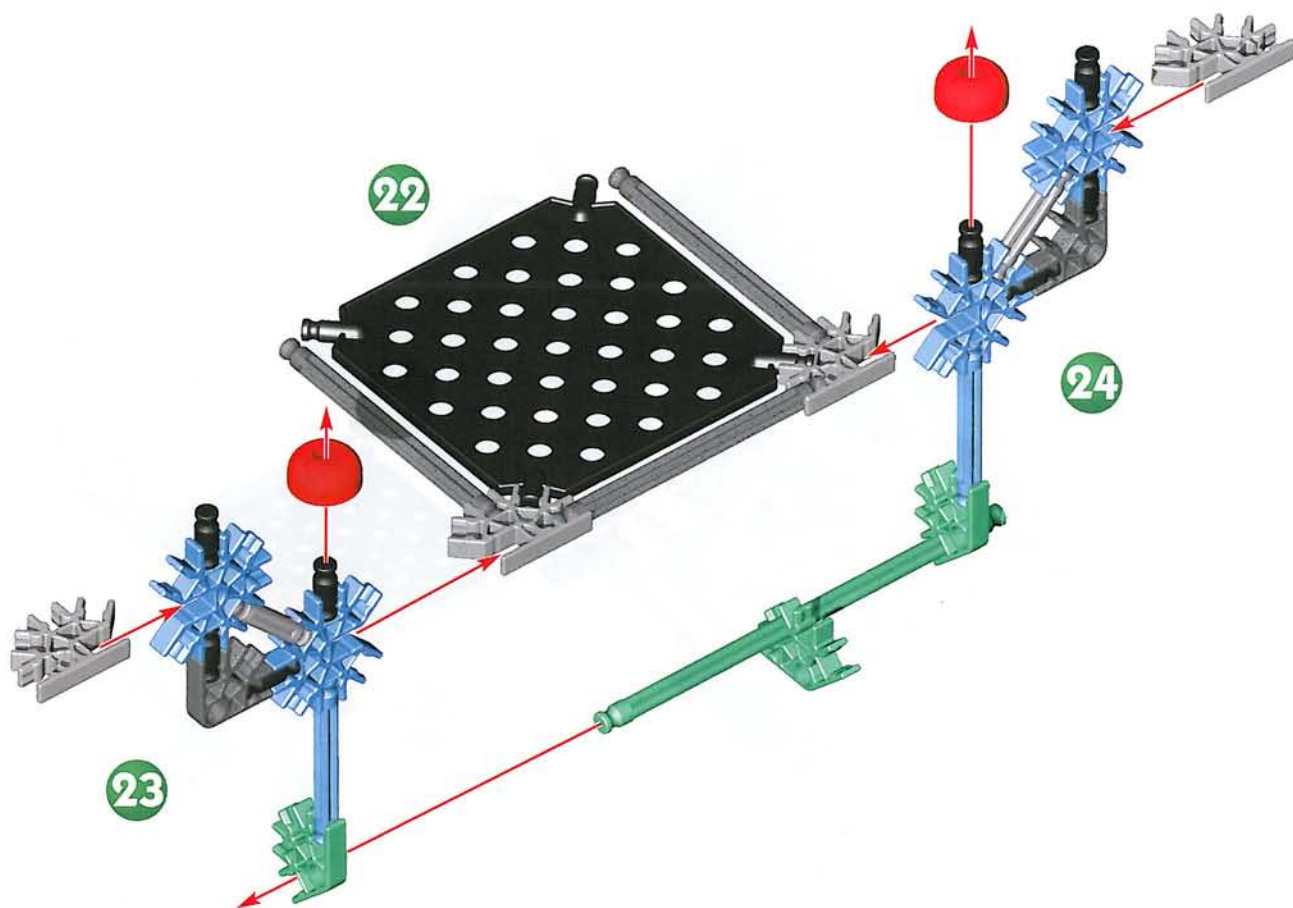

US GB Now attach it to the model.

F Fixe-la maintenant au modèle.

NL Het nu aan het model vastmaken.

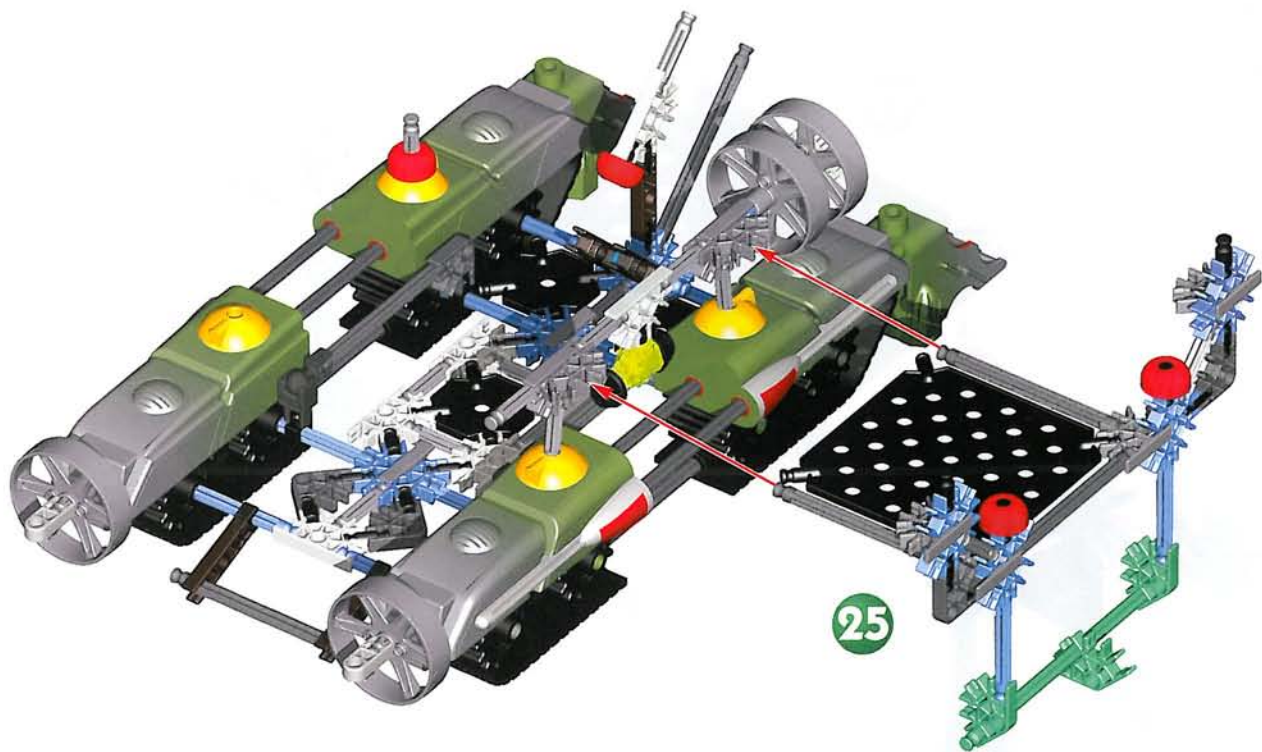

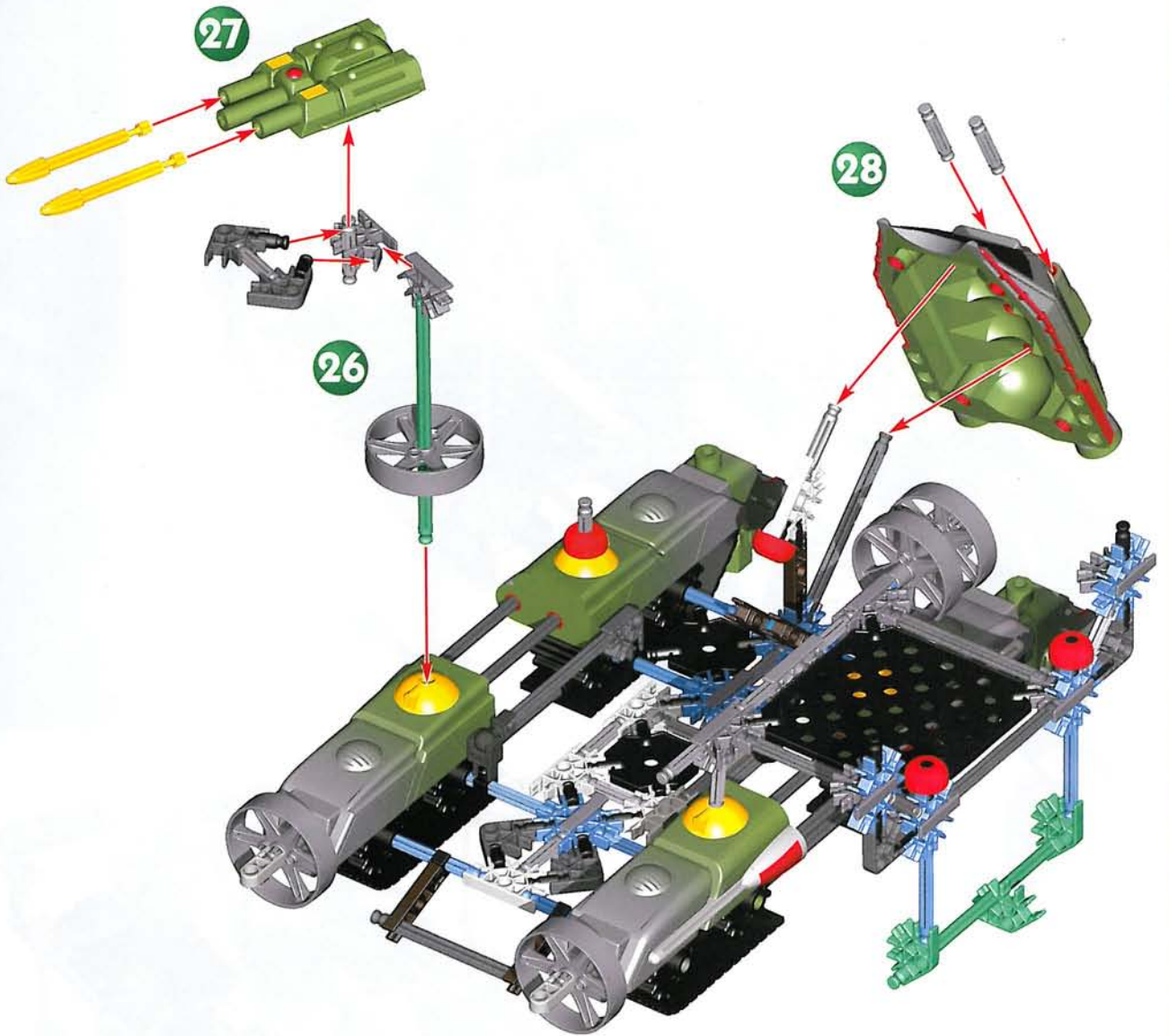

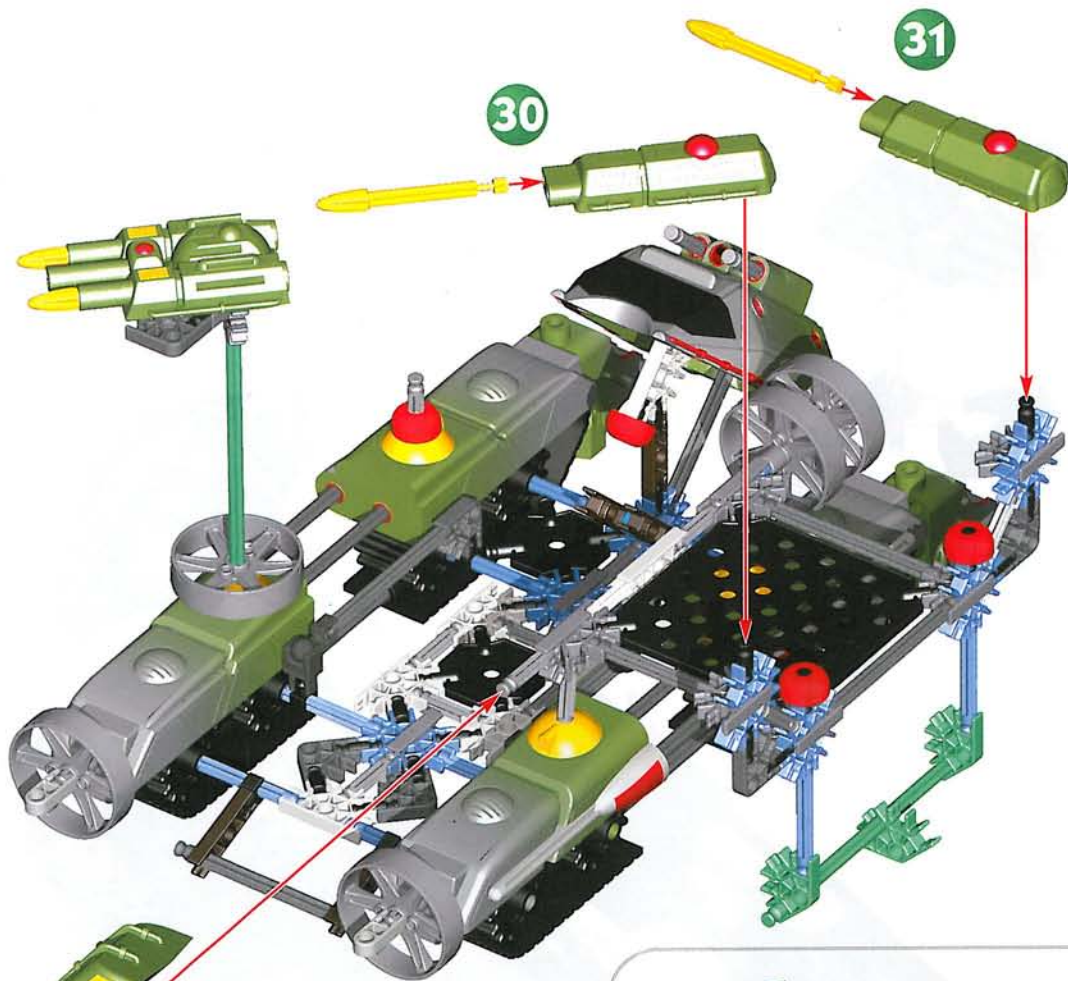

SPECIAL FEATURES *ATTRIBUTS SPÉCIAUX*

PRESS BUTTON TO FIRE MISSILES
*APPUYE SUR LE BOUTON POUR
PROPULSER LES MISSILES*

SONIC BOOM POWERCORE
*POWERCORE À BANG
SUPERSONIQUE*

**INSERT POWERCORE
TO LIGHT UP EYES**
*INSÉRER POWERCORE
POUR ILLUMINER
LES YEUX.*

BATTERING RAM
BÉLIER

Caution: Do not launch in the direction of people, animals, or walls; you could cause injury or damage. Never attempt to launch any projectiles other than K'NEX missiles.

Mise en garde : ne pas lancer en direction de personnes, d'animaux, ou de murs pour éviter le risque de blesser quelqu'un ou de provoquer des dégâts. Ne jamais tenter de lancer d'autres projectiles que les missiles K'NEX.

Opgelet: Niet lanceren in de richting van mensen, dieren of muren; je zou letsel of schade kunnen veroorzaken. Nooit proberen om andere projectielen dan K'NEX raketten te lanceren.

PARTS COUNT *NOMBRE DE PIÈCES*

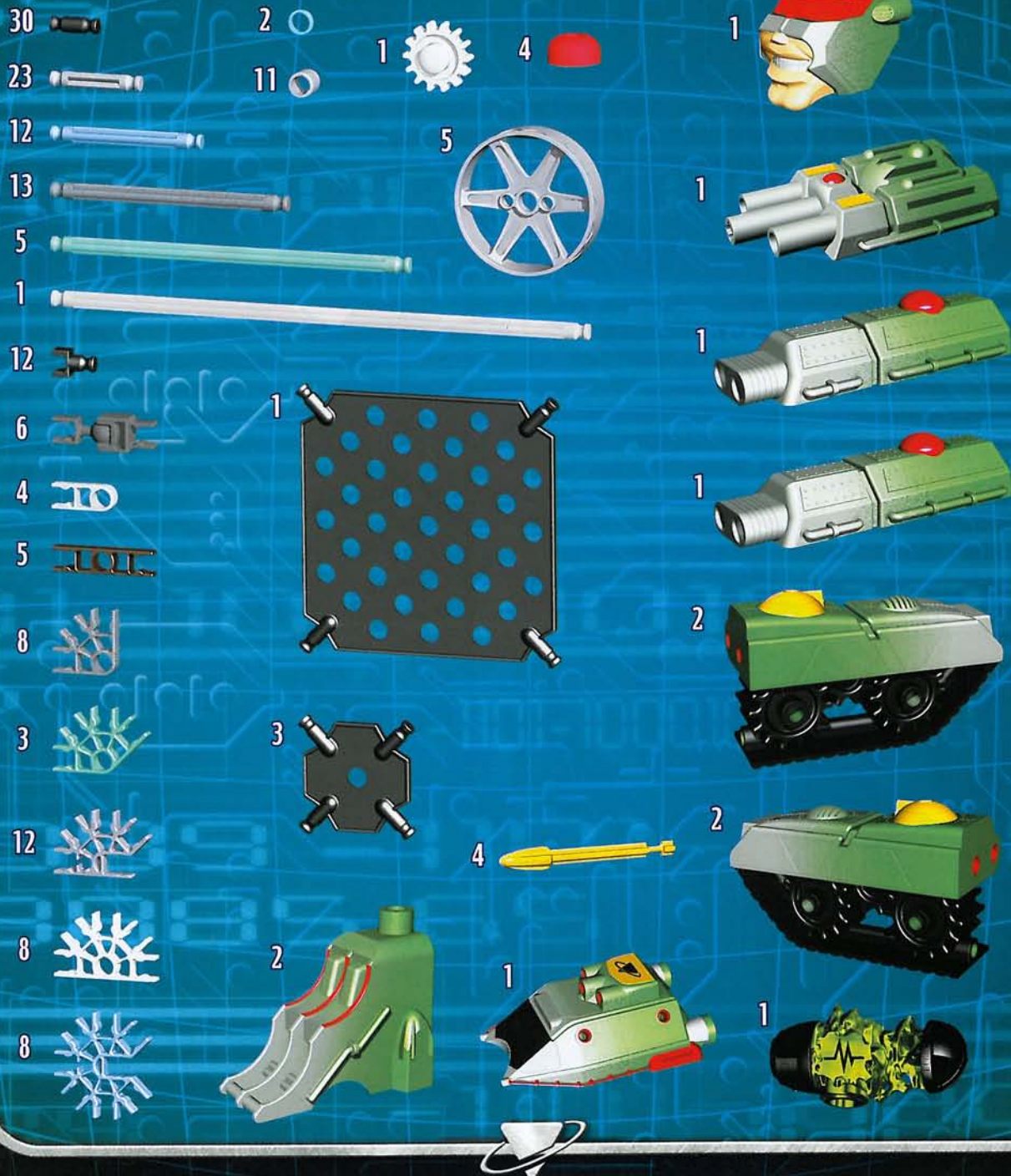

EXPERIENCE THE BATTLE ONLINE!

Enter THEIR World - Get the Story, Play the Game!

SUIVEZ LE COMBAT EN DIRECT!

Entre dans LEUR monde - Connais l'histoire, Joue le jeu!



www.REKONSTRUCTORS.com



©2003 K'NEX Industries, Inc. P.O. Box 700 Hatfield, PA 19440-0700



US 1-800-KID-KNEX US/Canada only (English only)

GB 00800-22427276 UK/Ireland only

F E D NL 001-215-996-4823



**US Consumer Services
K'NEX Industries, Inc.
P.O. Box 700
Hatfield, PA 19440-0700**



**GB K'NEX
Newport Consumer Services
Hasbro UK Ltd., Caswell Way
Newport, Gwent NP9 0YH**



www.knex.com



email@knex.com



WARNING:

CHOKING HAZARD- Small parts.
Not for children under 3 years.



AVERTISSEMENT:

DANGER D'ÉTOUFFEMENT- Pièces de petite
taille Ne pas donner aux enfants de moins de 3 ans.



WAARSCHUWING:

VERSTIKKINGSGEVAAR- In verband met kleine
onderdelen niet geschikt voor kinderen tot 3 jaar.

Printed in China
Imprimerie aux China

Product and colors may vary. Models can be built one at a time. K'NEX is a registered trademark of K'NEX Industries, Inc. Le produit et les couleurs peuvent varier. La plupart des modèles peuvent être construits un à la fois. K'NEX est une marque déposée de K'NEX Industries, Inc.

Manufactured under U.S. Patents/Fabriqué sous brevets américains 5,061,219; 5,137,486; 5,199,919; 6,460,572. Other U.S. and foreign patents pending. Autres brevets américains et étrangers en instance.

Conforms to the Requirements of ASTM Standard Consumer Safety Specification on Toy Safety, F963-96a. Conforme aux spécifications de sécurité du consommateur sur la sécurité des jouets de la norme ASTM F963-96a.



403025.11