



# MARIO KART™

Wii

6+

**2** Motorized Karts  
Karts Motorizado  
Karts Motorisé

**ULTIMATE COMBINATION  
BUILDING SET™**



38565

# K'NEX®



1

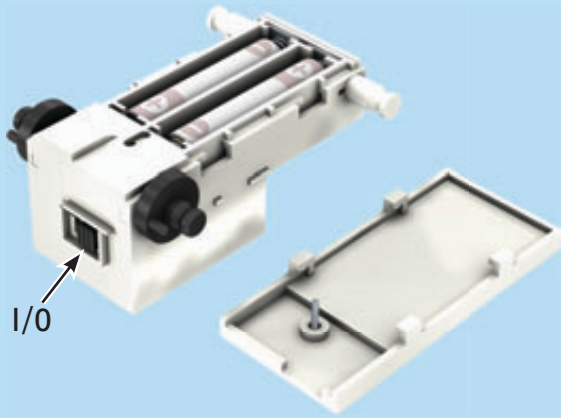

2

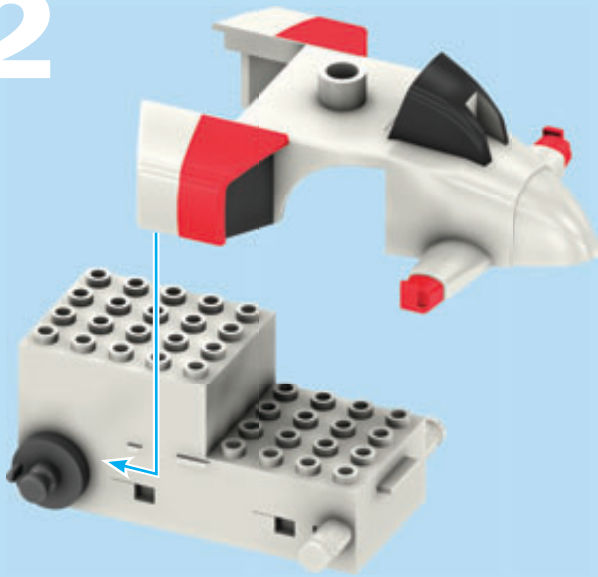

# MARIOKART™

## Wii

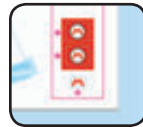

- Apply stickers
- Aplicar pegatinas
- Appelez des autocollants
- Anbringen von Aufklebern
- Applicare gli adesivi
- Aplicar adesivos
- Aanbrengen stickers

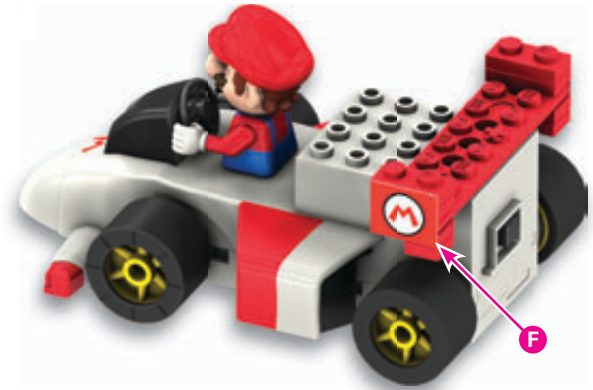

**WARNING:** CHOKING HAZARD – SMALL PARTS.  
Not for children under 3 years.

**ADVERTENCIA:** PELIGRO DE ASFIXIA – PIEZAS PEQUEÑAS. No para niños menores de 3 años.

**ATTENTION !** RISQUE D'ÉTOUFFEMENT – Pièces de petite taille. Ne convient pas aux enfants de moins de 3 ans.

**WARNHINWEIS:** ERSTICKUNGSGEFAHR – KLEINTEILE. Nicht geeignet für Kinder unter 3 Jahren.

**AVVERTENZA:** PERICOLO DI SOFFOCAMENTO – CONTIENE PICCOLE PARTI. Non adatto per bambini al di sotto di 3 anni.

**AVISO:** PERIGO DE SUFOCAÇÃO – PEÇAS PEQUENAS. Não se destina a crianças com menos de 3 anos de idade.

**WAARSCHUWING:** VERSTIKKINGSGEVAAR – KLEINE ONDERDELEN. Niet geschikt voor kinderen onder 3.

3

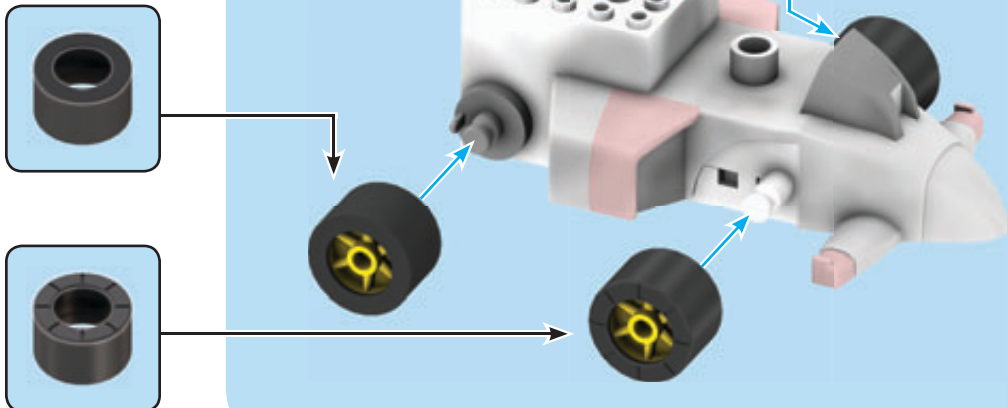

4

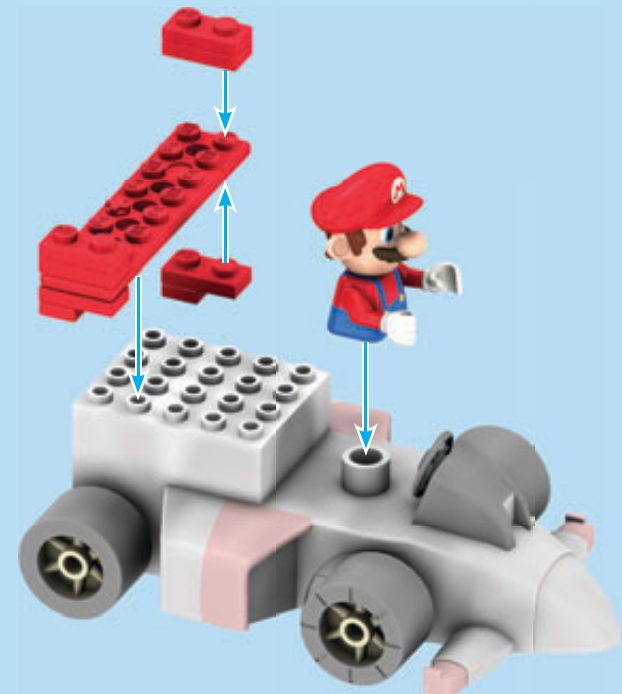

1

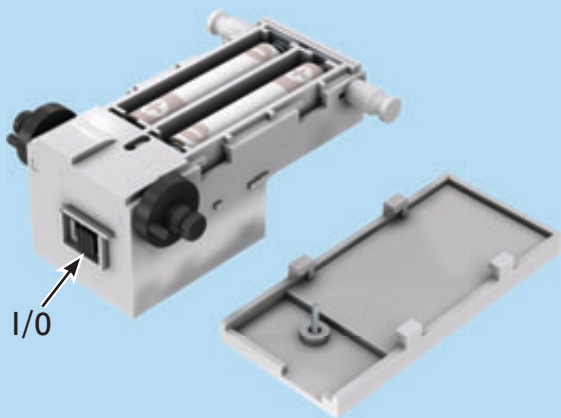

2

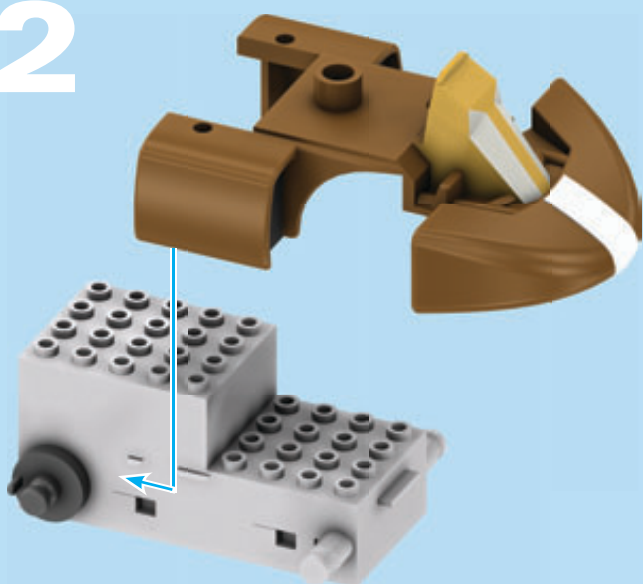

3

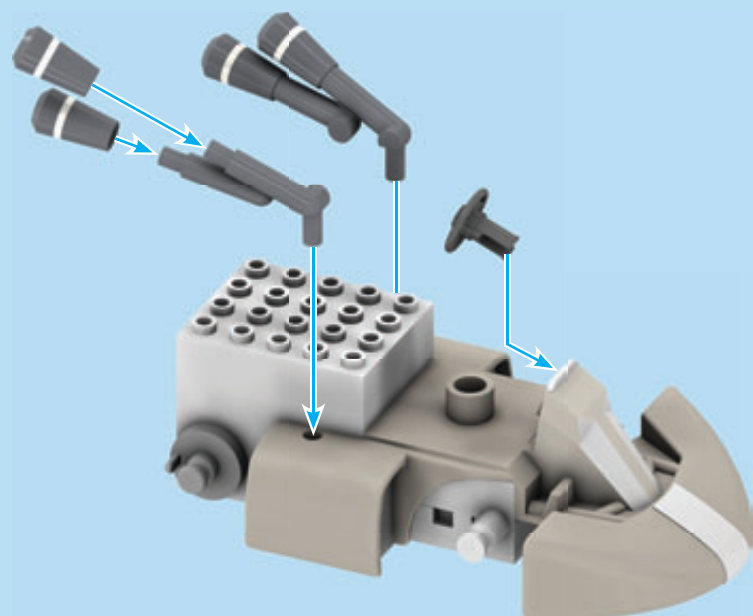

4

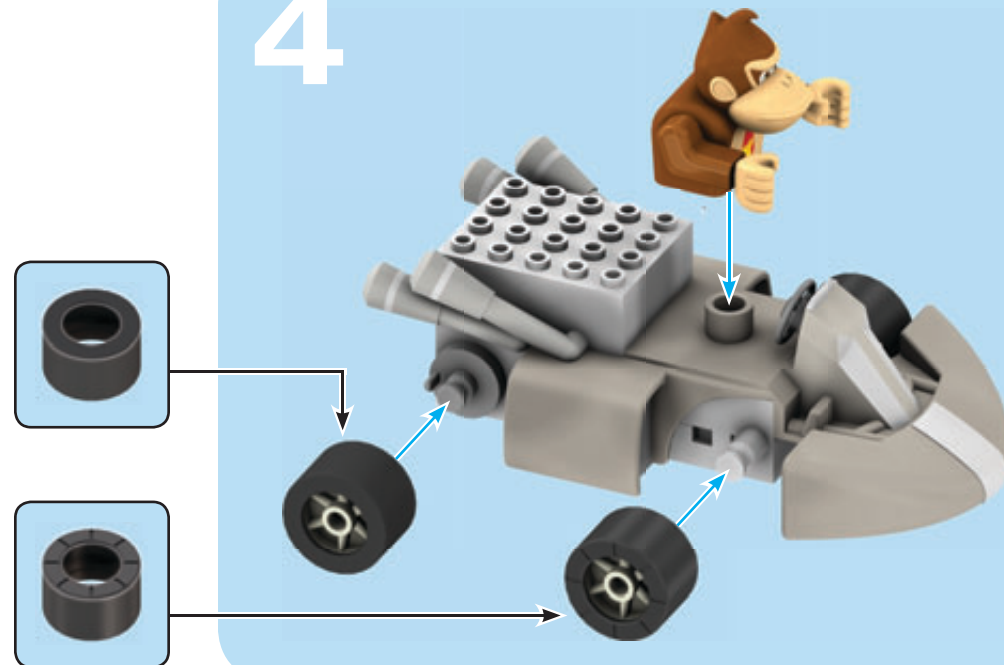

# MARIOKART™

## Wii

**⚠ WARNING: CHOKING HAZARD – SMALL PARTS.**  
Not for children under 3 years.

**ADVERTENCIA: PELIGRO DE ASFIXIA – PIEZAS PEQUEÑAS.** No para niños menores de 3 años.

**ATTENTION ! RISQUE D'ÉTOUFFEMENT – Pièces de petite taille.** Ne convient pas aux enfants de moins de 3 ans.

**WARNHINWEIS: ERSTICKUNGSGEFAHR – KLEINTEILE.** Nicht geeignet für Kinder unter 3 Jahren.

**AVVERTENZA: PERICOLO DI SOFFOCAMENTO – CONTIENE PICCOLE PARTI.** Non adatto per bambini al di sotto di 3 anni.

**AVISO: PERIGO DE SUFOCAÇÃO – PEÇAS PEQUENAS.** Não se destina a crianças com menos de 3 anos de idade.

**WAARSCHUWING: VERSTIKKINGSGEVAAR – KLEINE ONDERDELEN.** Niet geschikt voor kinderen onder 3.

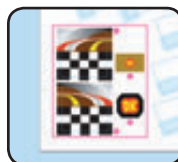
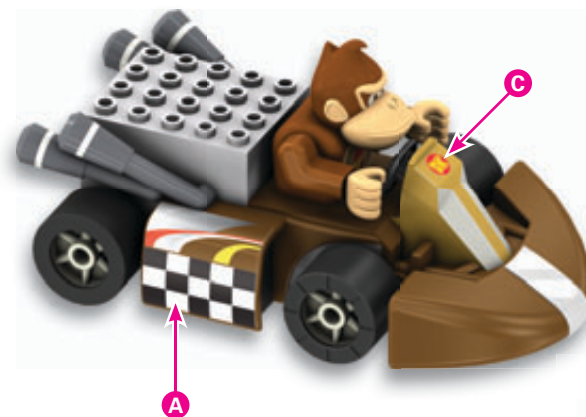

- Apply stickers
- Aplicar pegatinas
- Appez des autocollants
- Anbringen von Aufklebern
- Applicare gli adesivi
- Aplicar adesivos
- Aanbrengen stickers





=

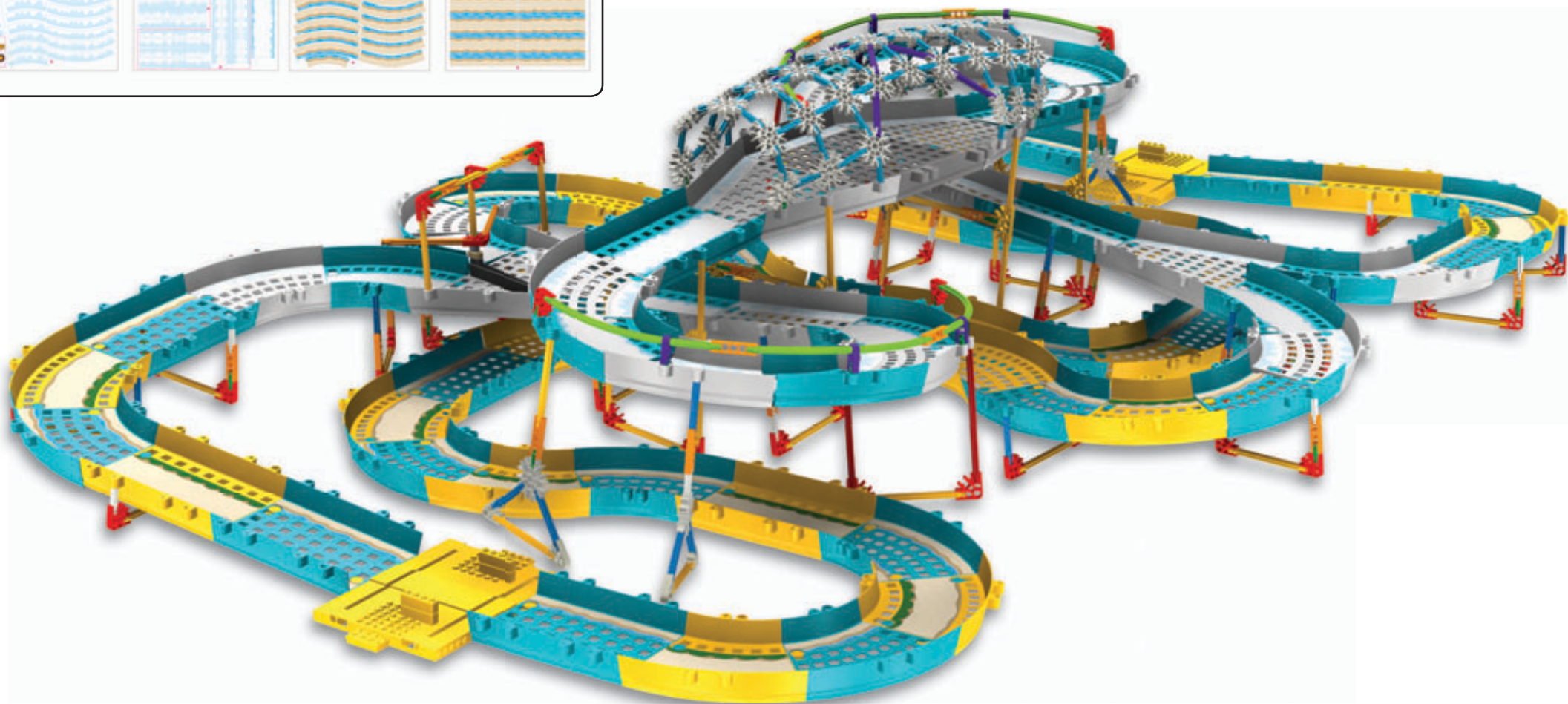
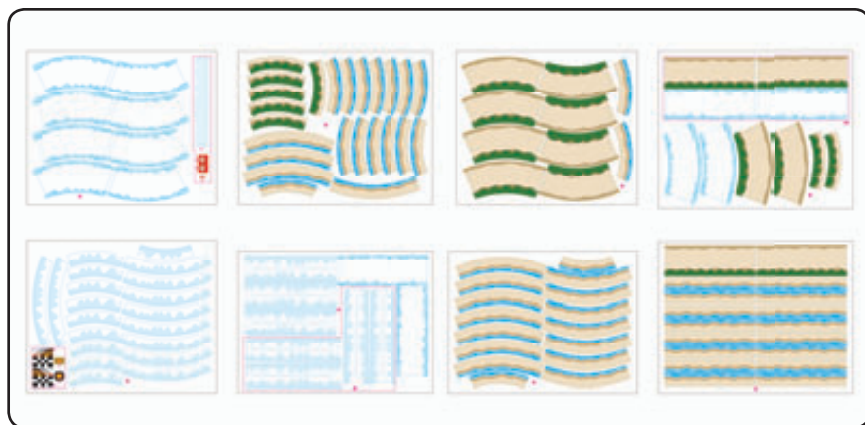
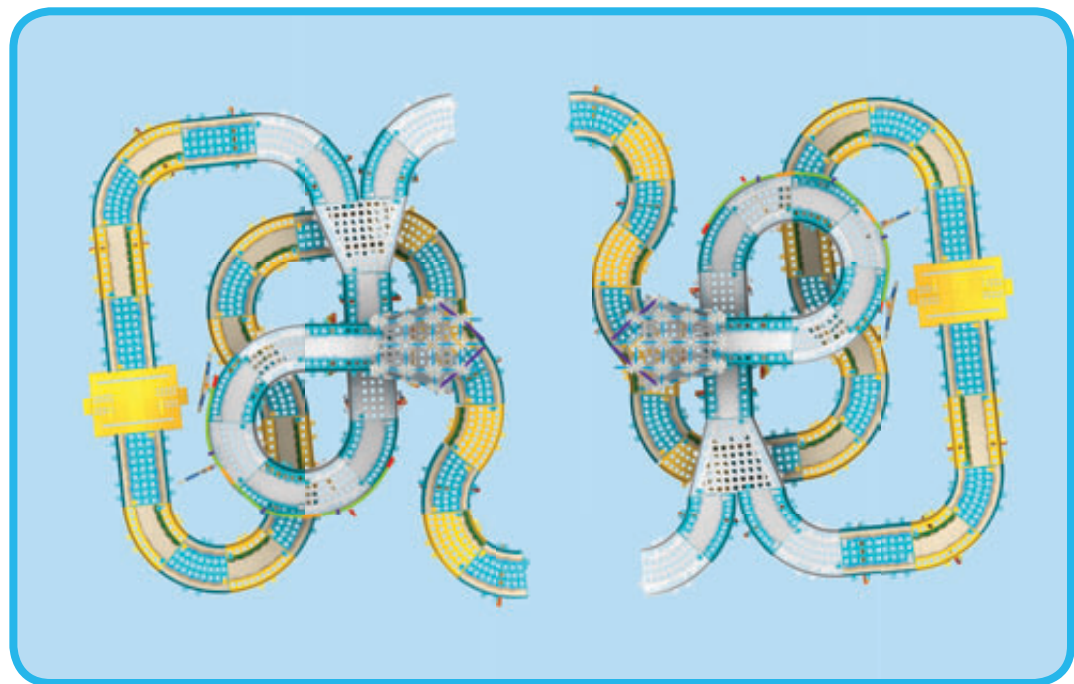

# 2



# x2

# 1

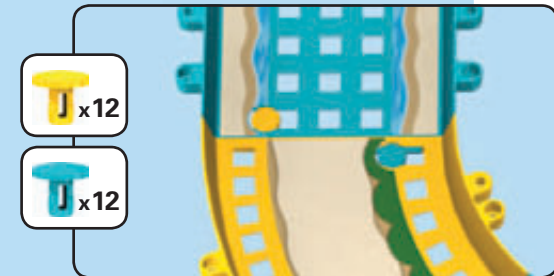
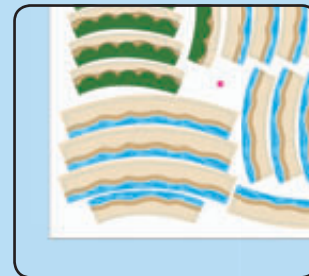
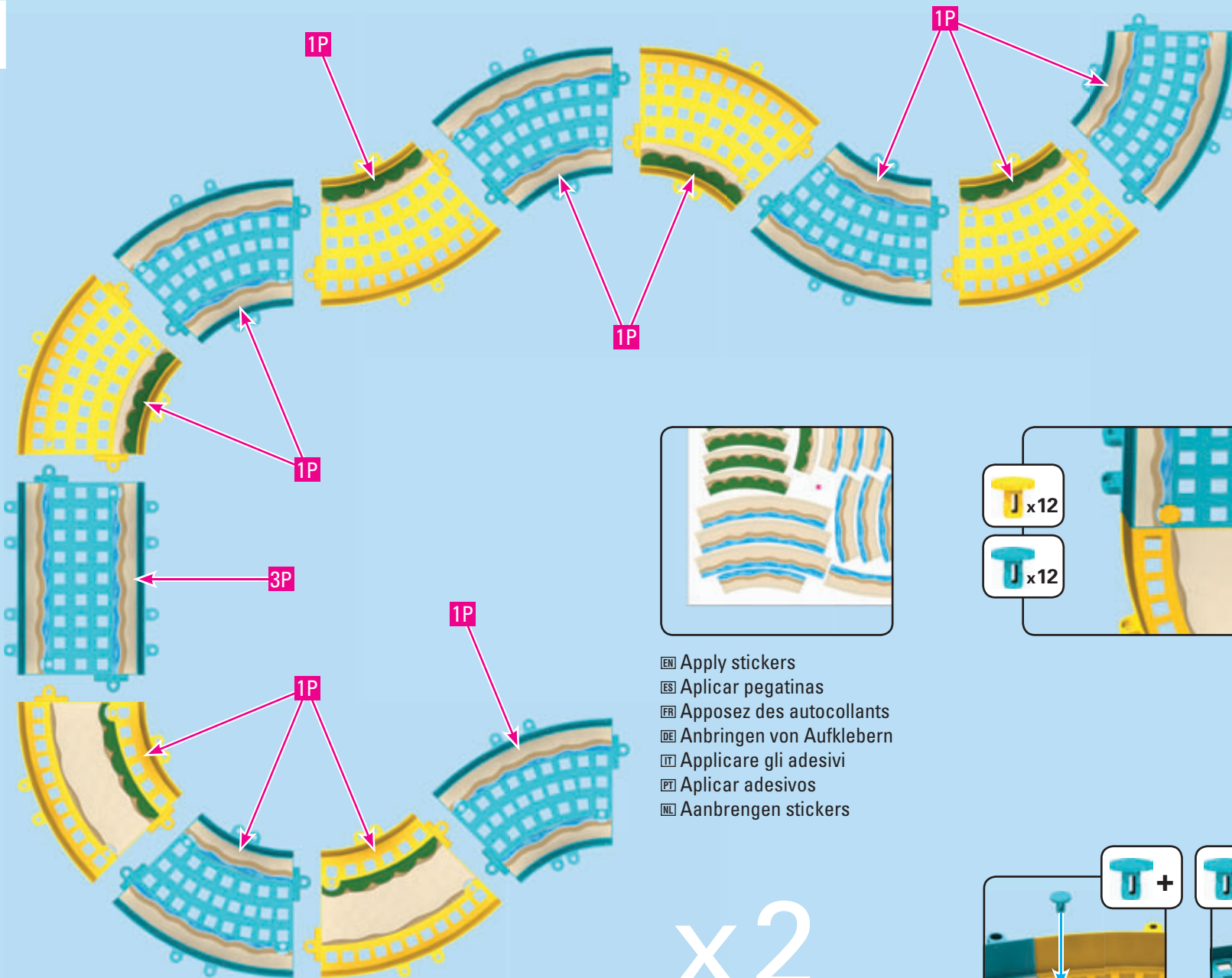

- Apply stickers
- Aplicar pegatinas
- Appezer des autocollants
- Anbringen von Aufklebern
- Applicare gli adesivi
- Aplicar adhesivos
- Aanbrengen stickers

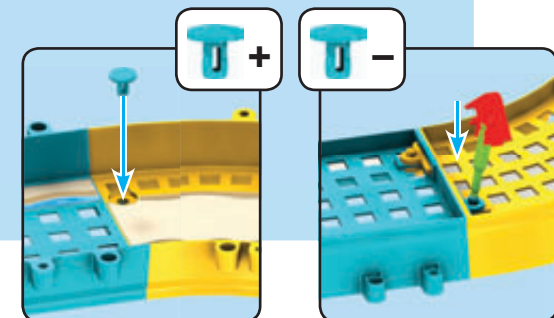

# x2

3

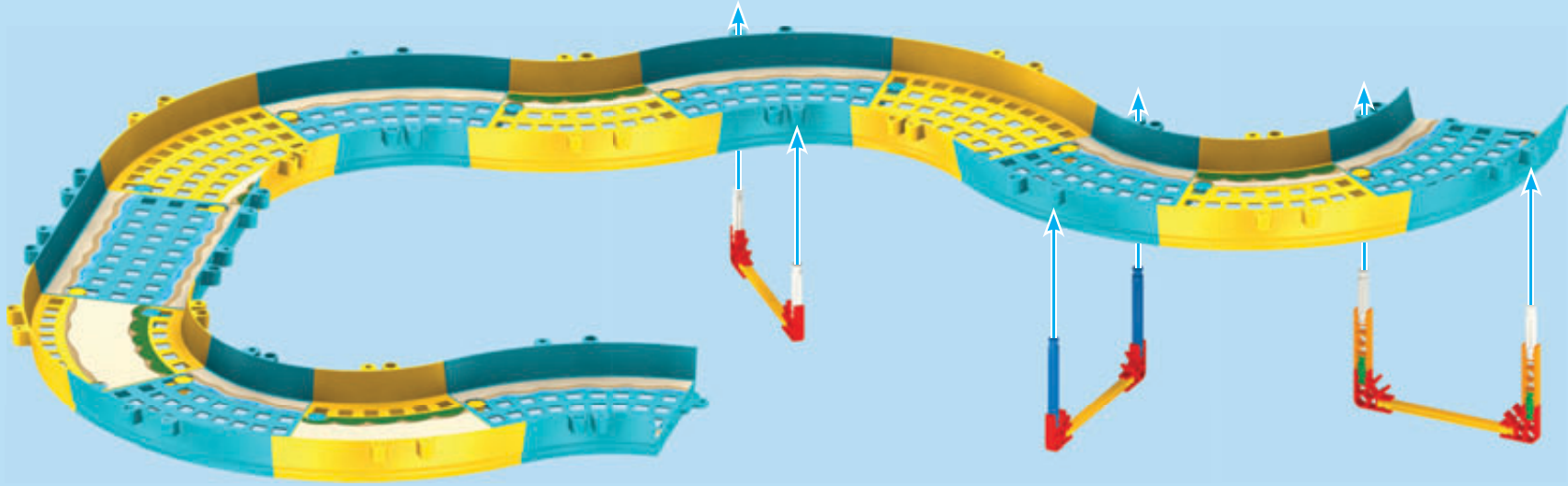

x2

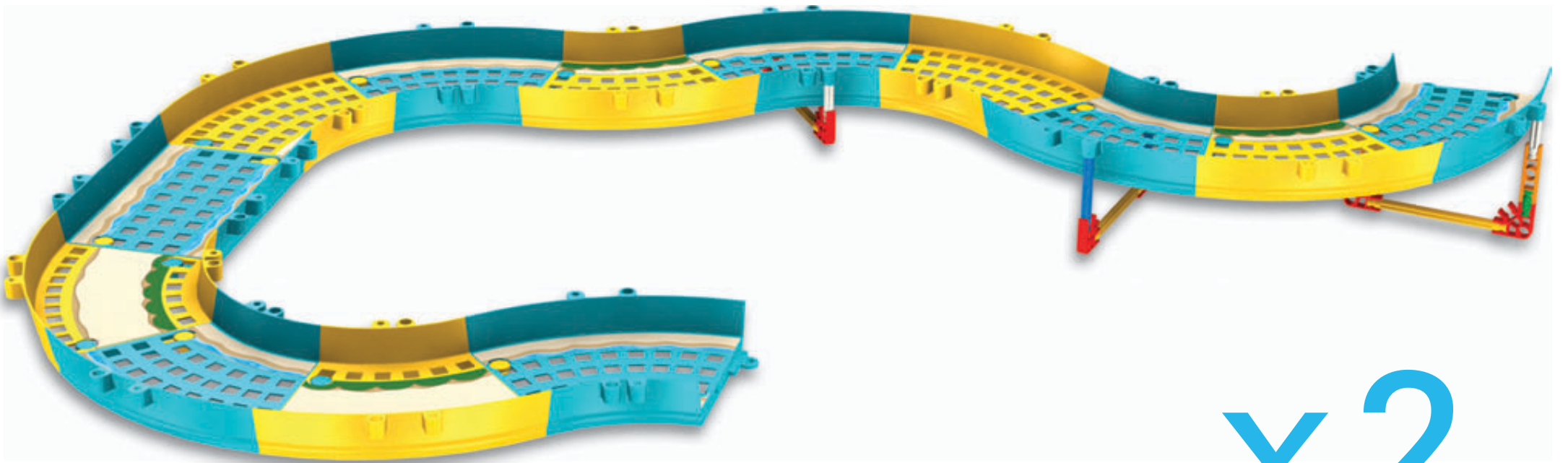
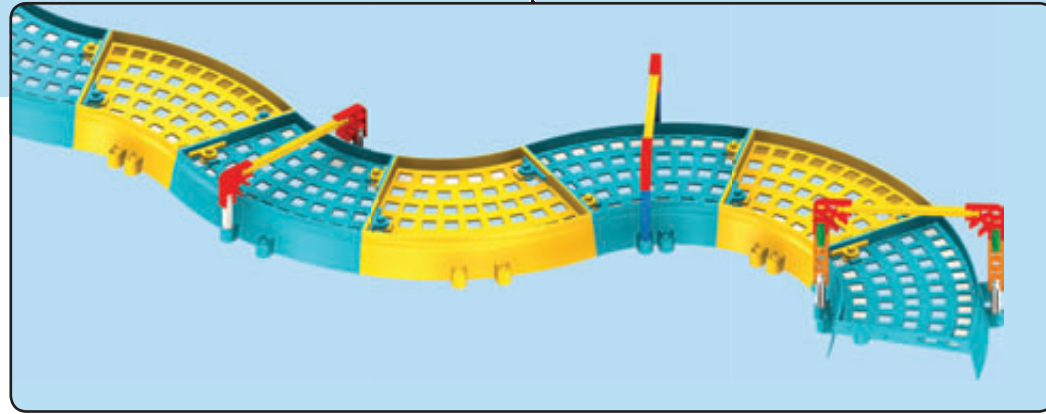

x2

# 1

- Apply stickers
- Aplicar pegatinas
- Appelez des autocollants
- Anbringen von Aufklebern
- Applicare gli adesivi
- Aplicar adhesivos
- Aanbrengen stickers

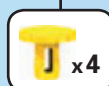
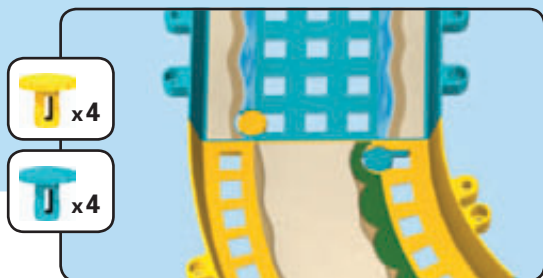
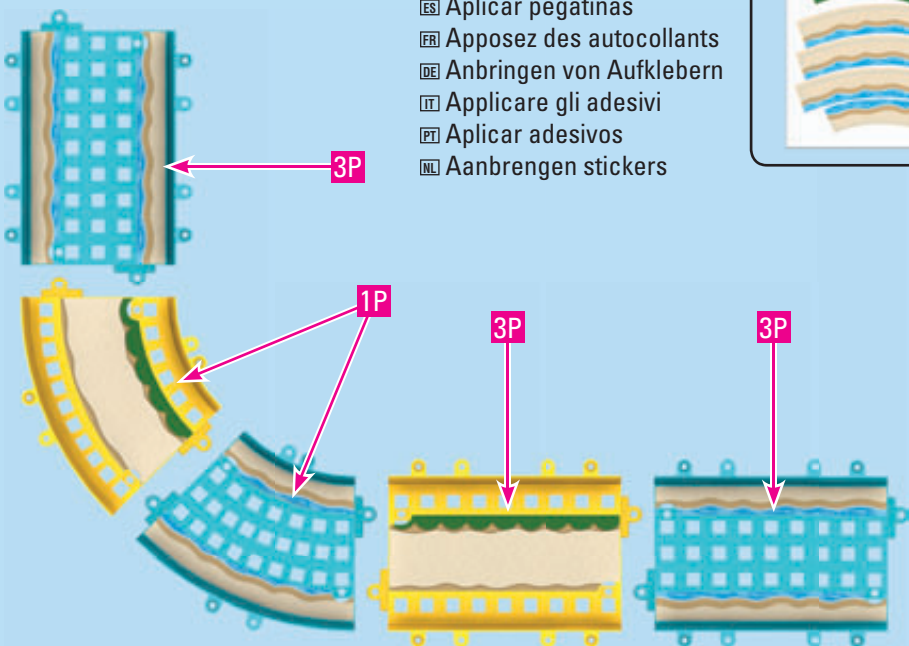
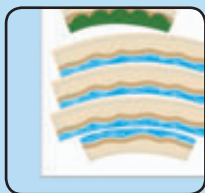

# x2

# 2

# x2

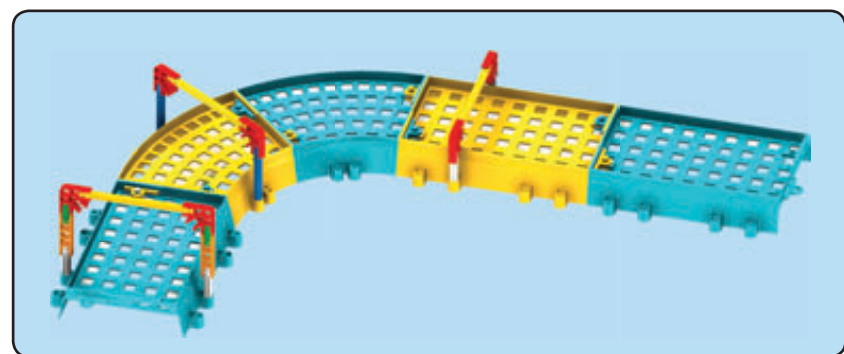
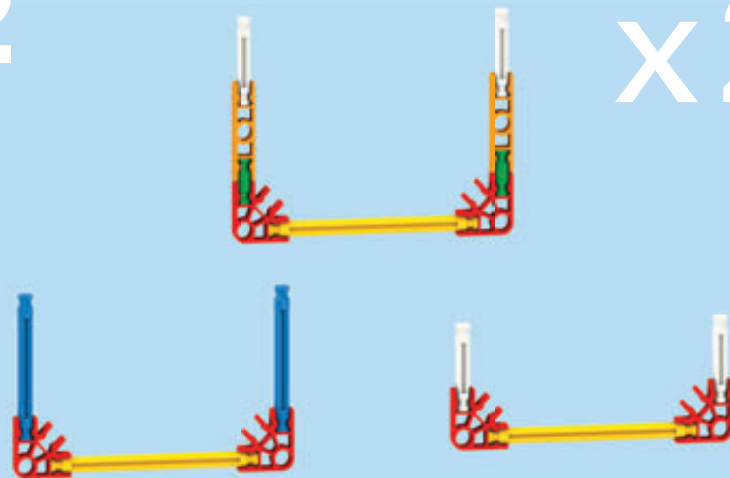

# 5

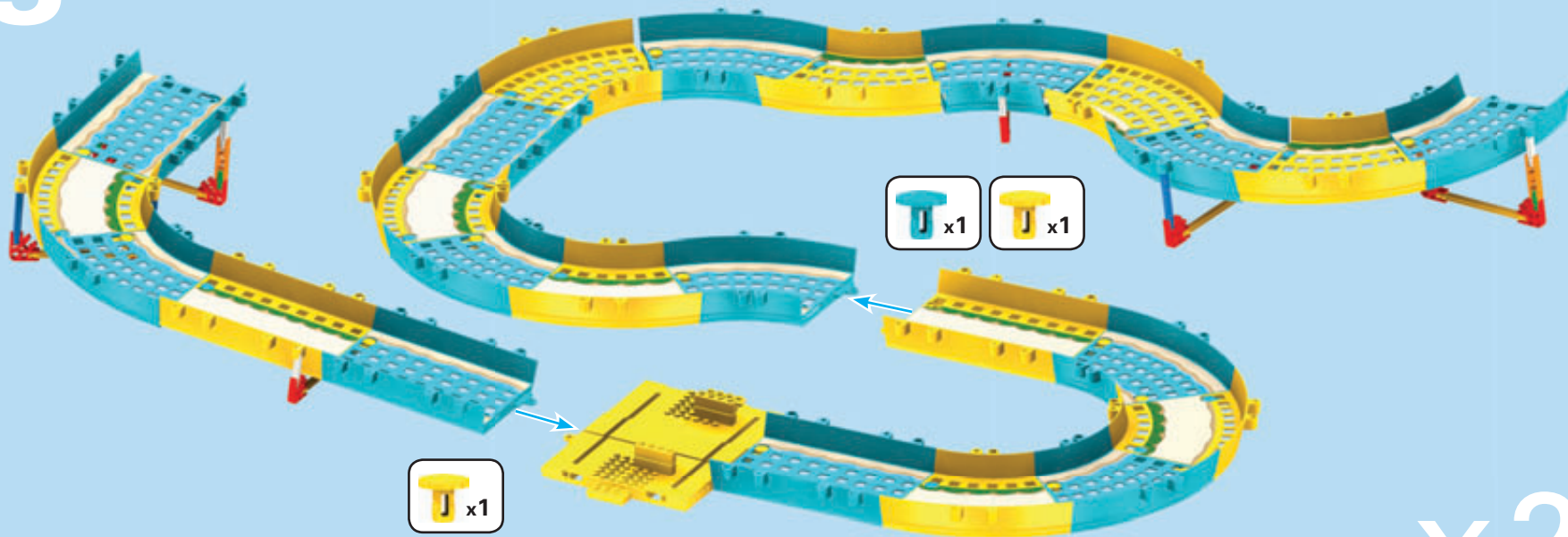

# x2

3

x2

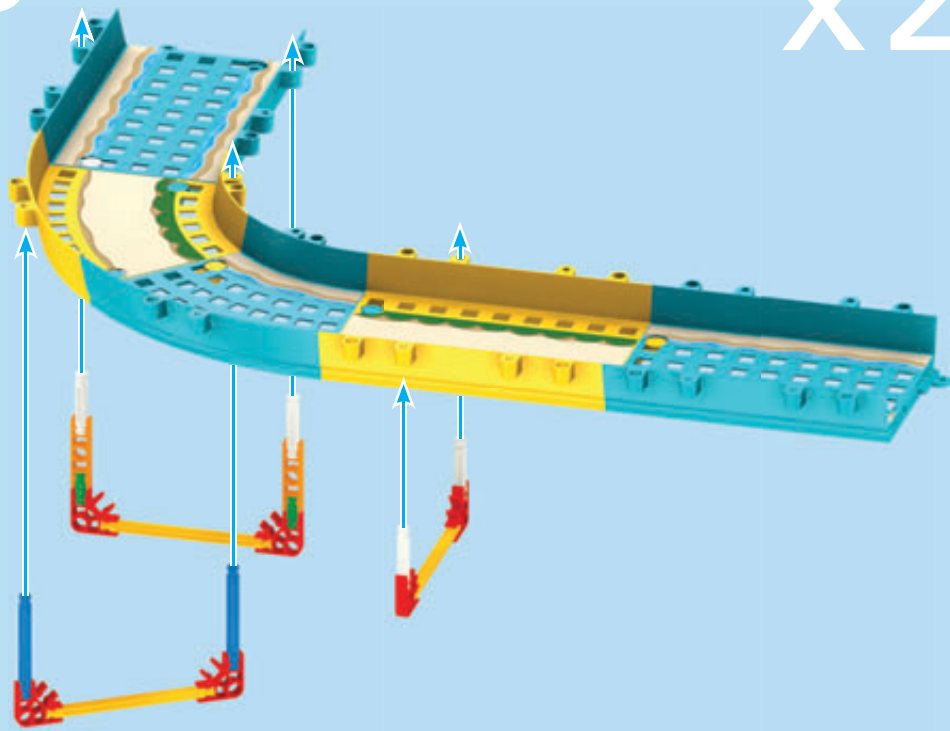

4

x2

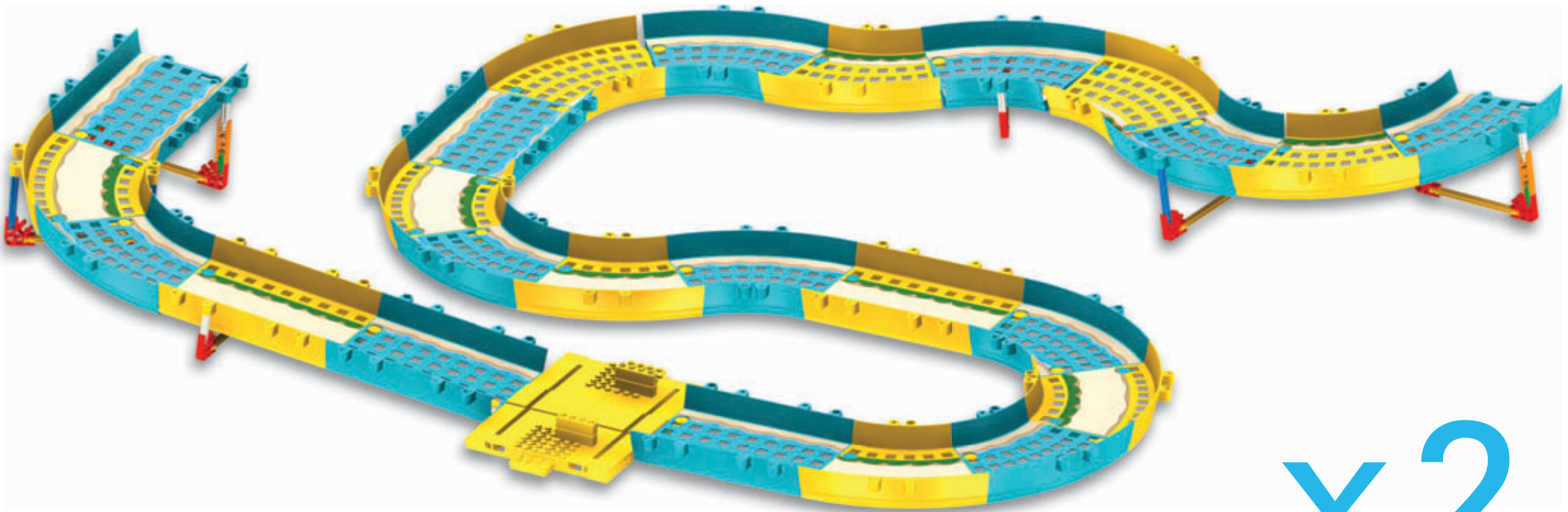
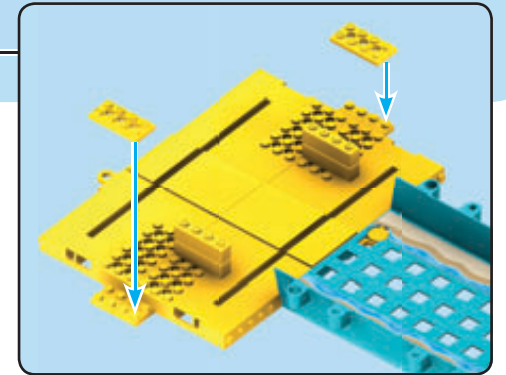
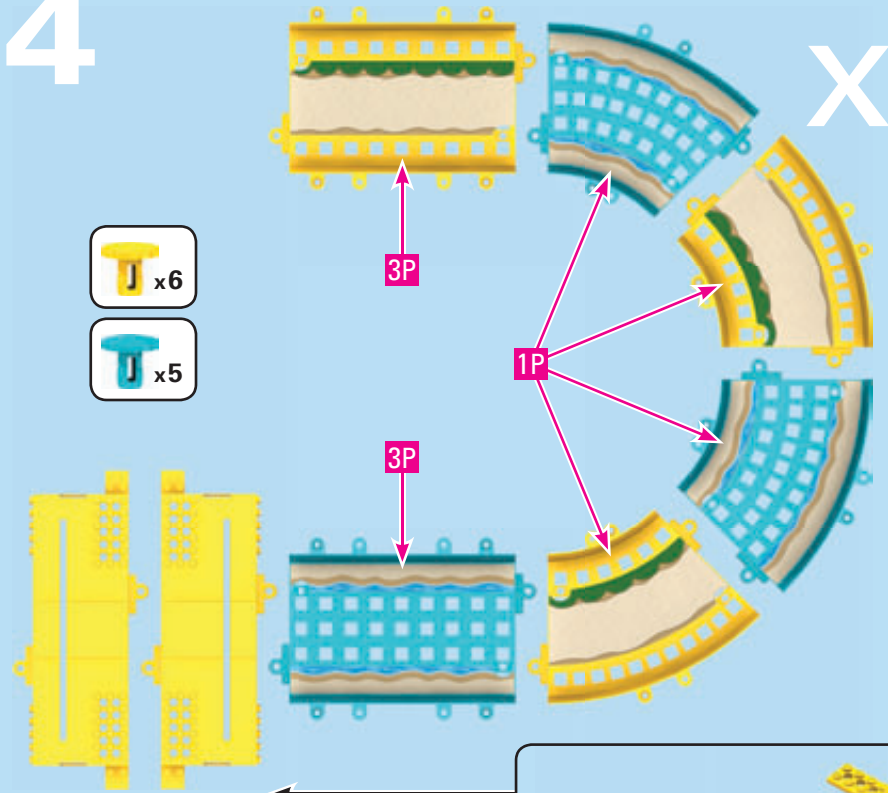

x2

# 1

- ☒ Apply stickers
- ☒ Aplicar pegatinas
- ☒ Appelez des autocollants
- ☒ Anbringen von Aufklebern
- ☒ Applicare gli adesivi
- ☒ Aplicar adesivos
- ☒ Aanbrengen stickers

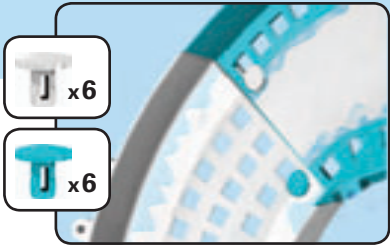
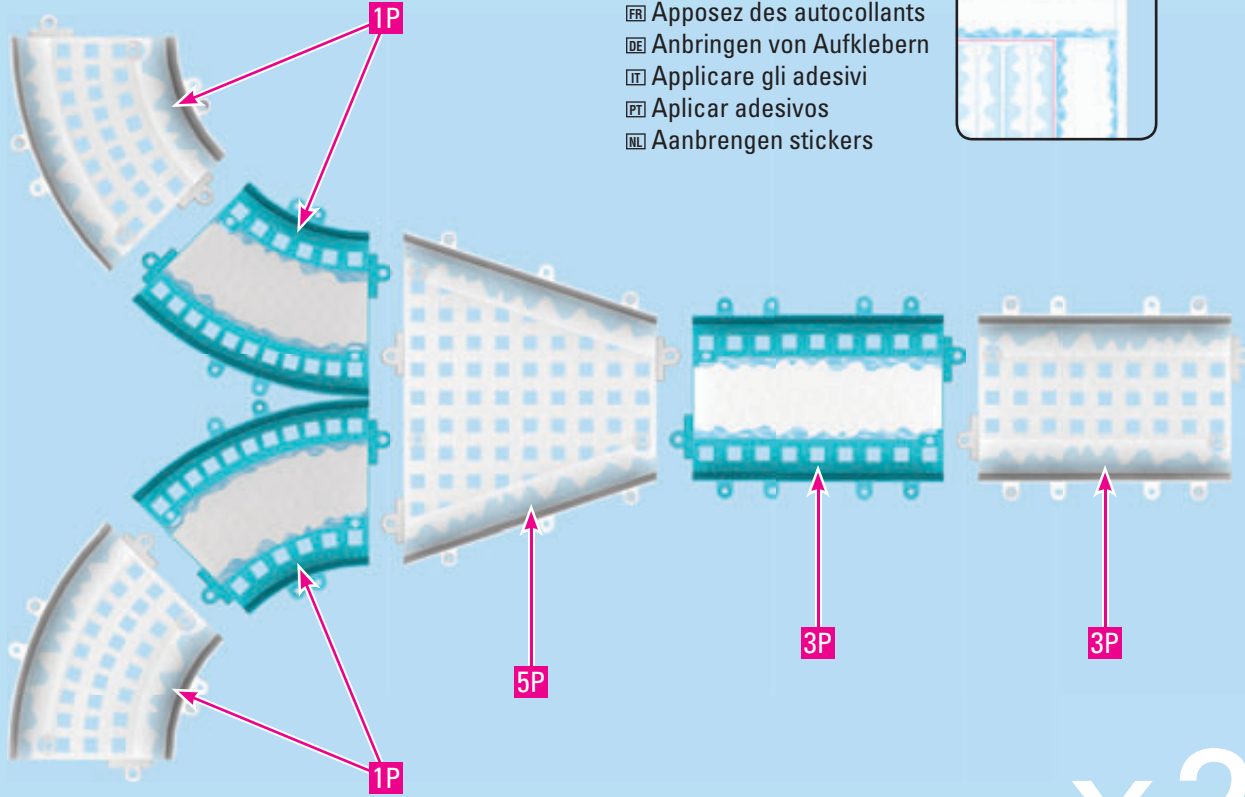
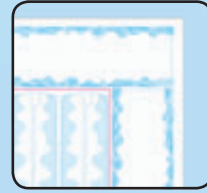

# 2

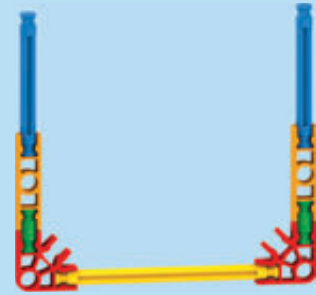

# x6

# 3



# x2

# 5

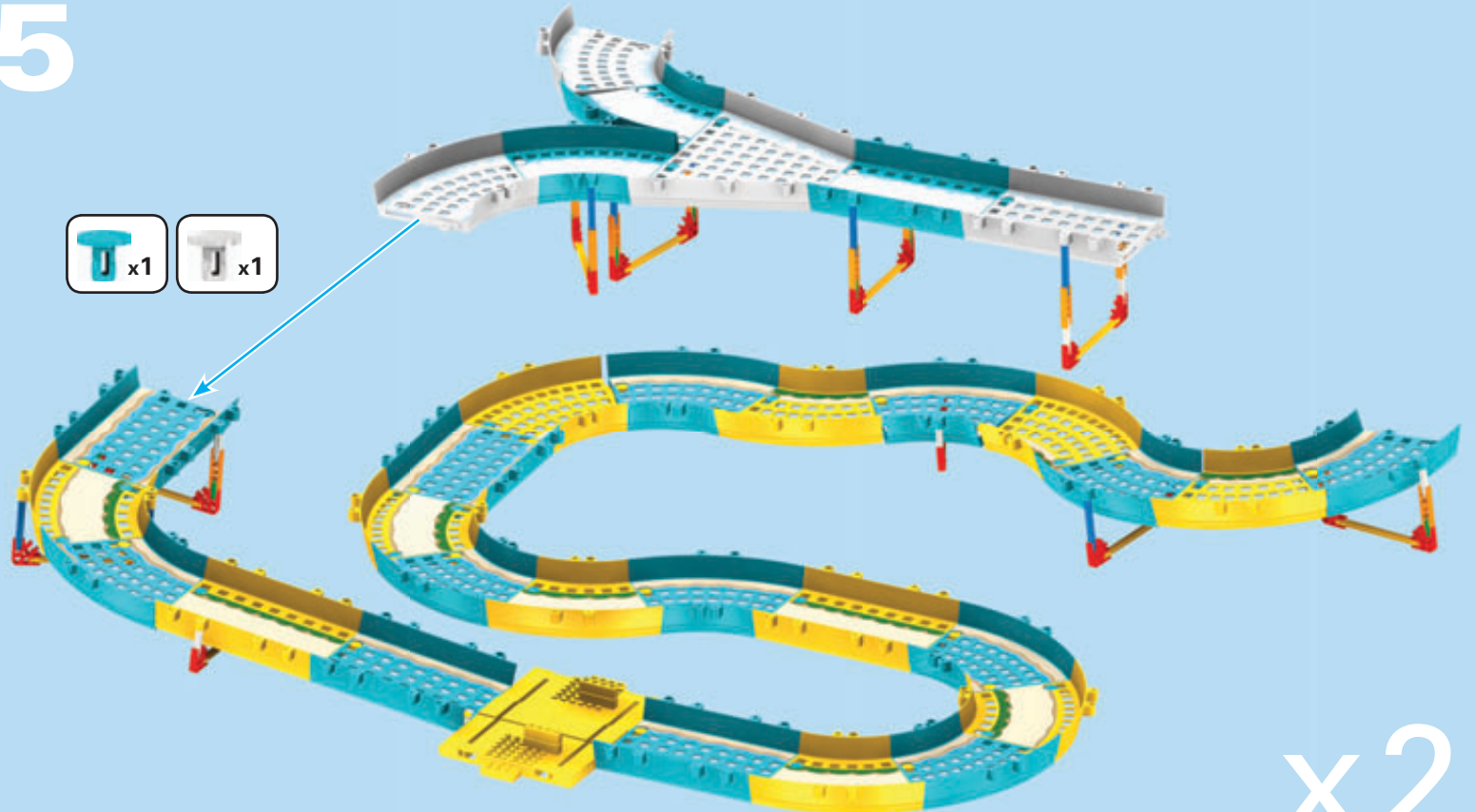
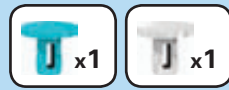

# x2

4

x2

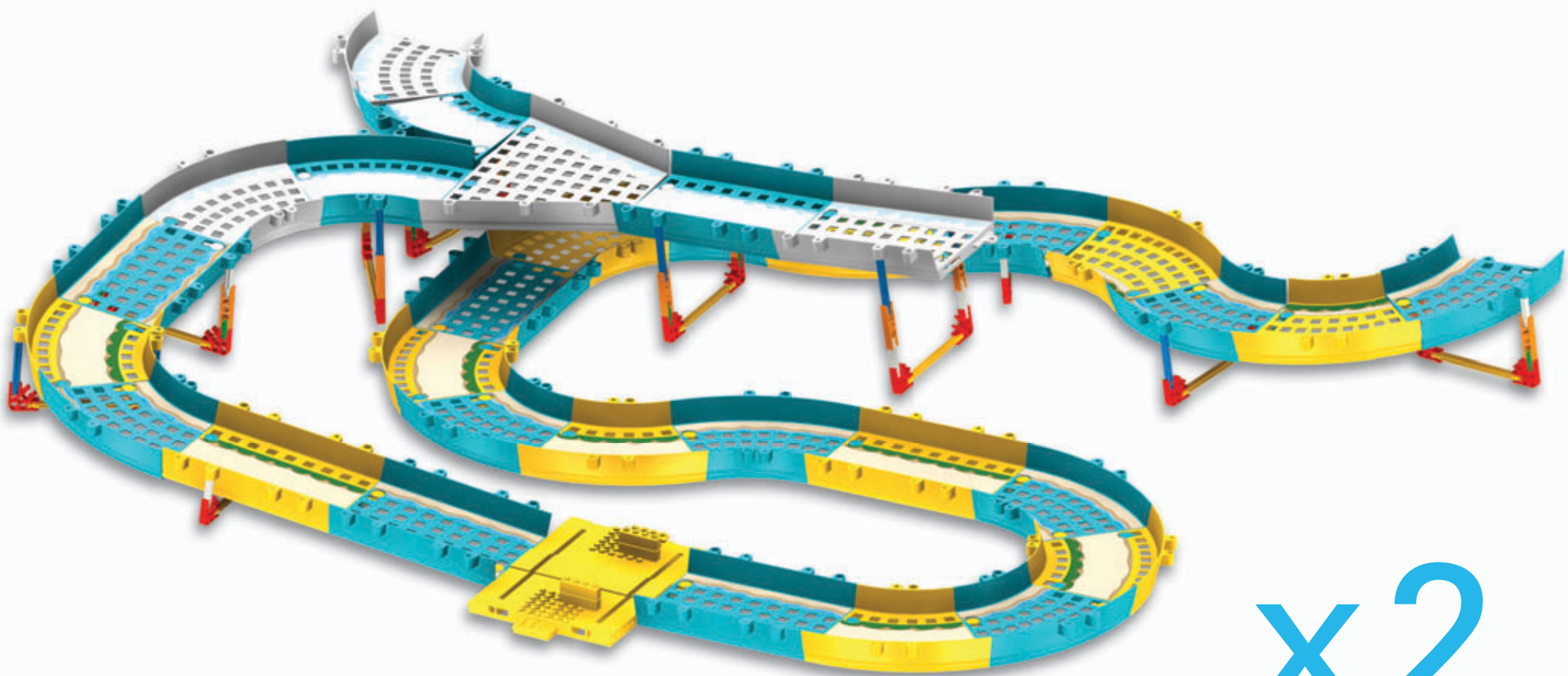
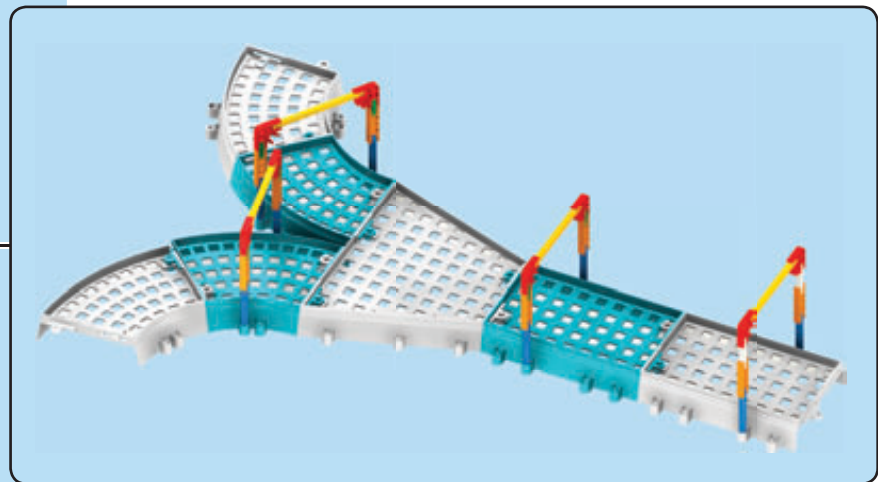
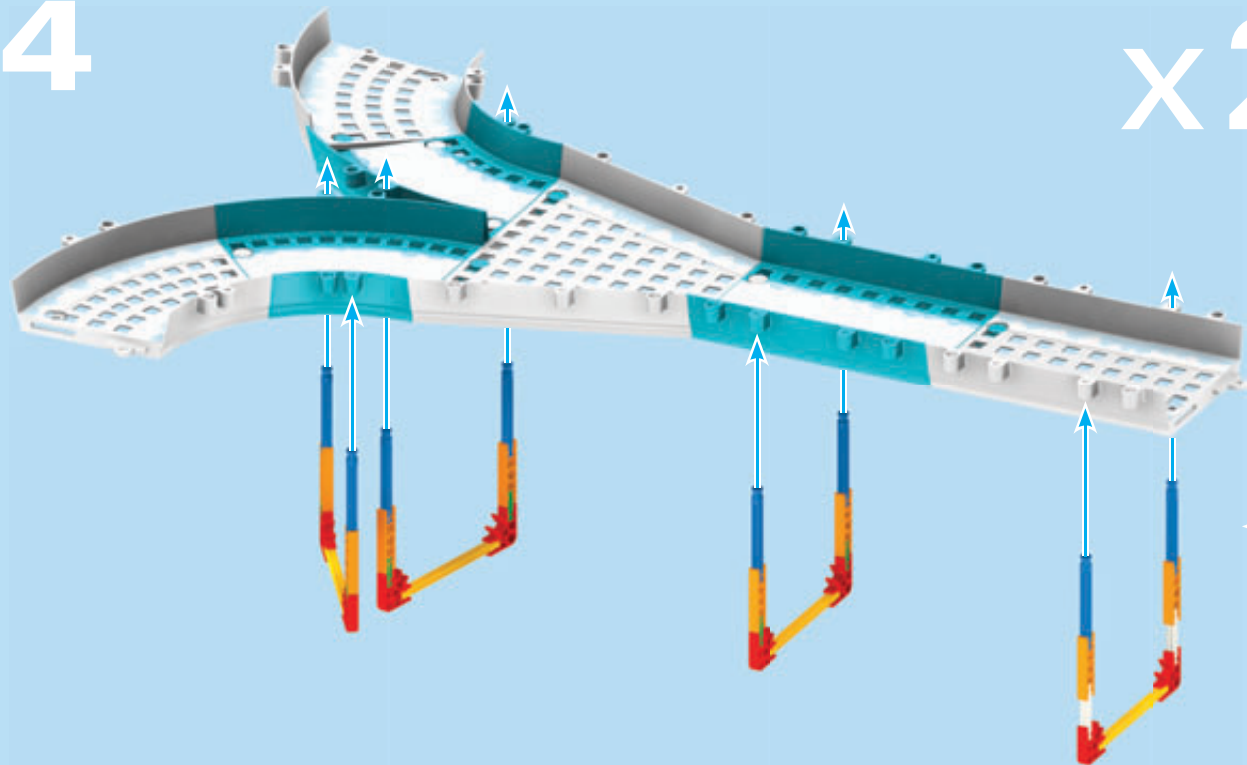

x2

# 1

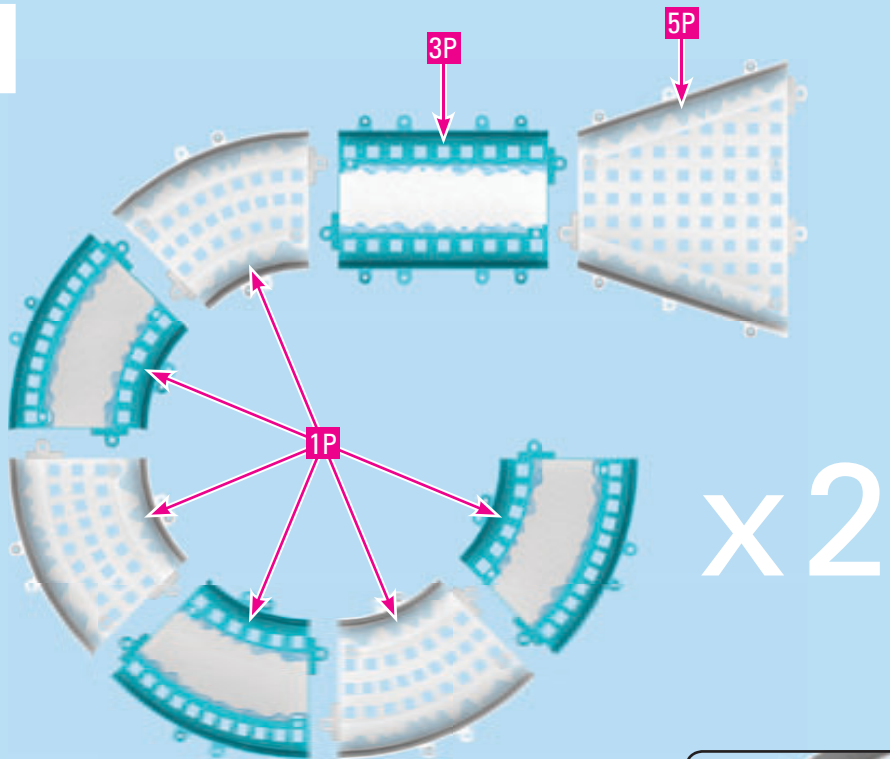

- Apply stickers
- Aplicar pegatinas
- Appelez des autocollants
- Anbringen von Aufklebern
- Applicare gli adesivi
- Aplicar adhesivos
- Aanbrengen stickers

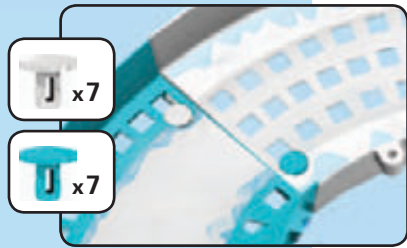
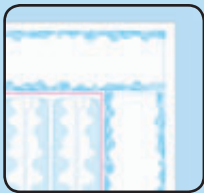

# 2

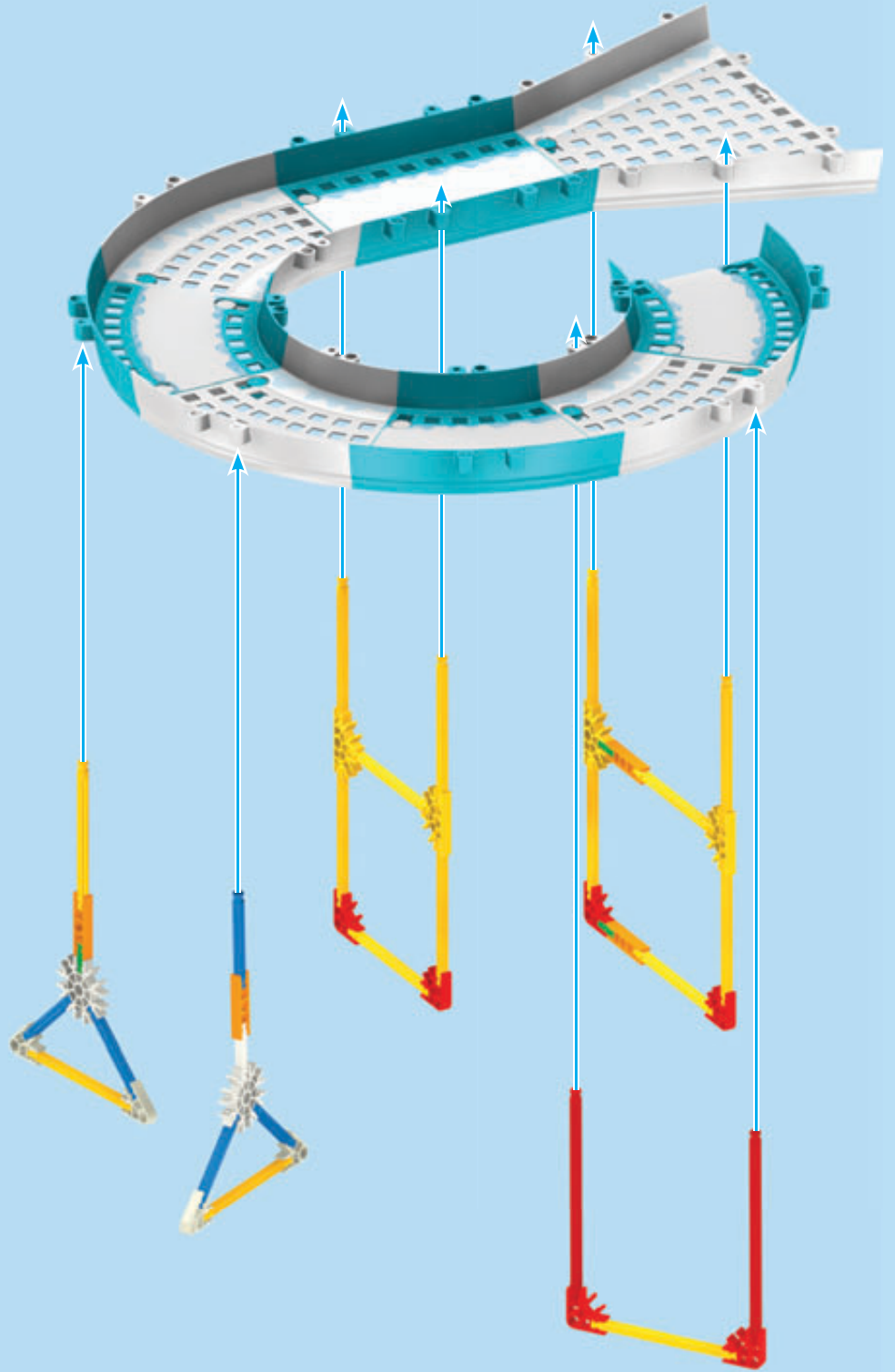

# x2

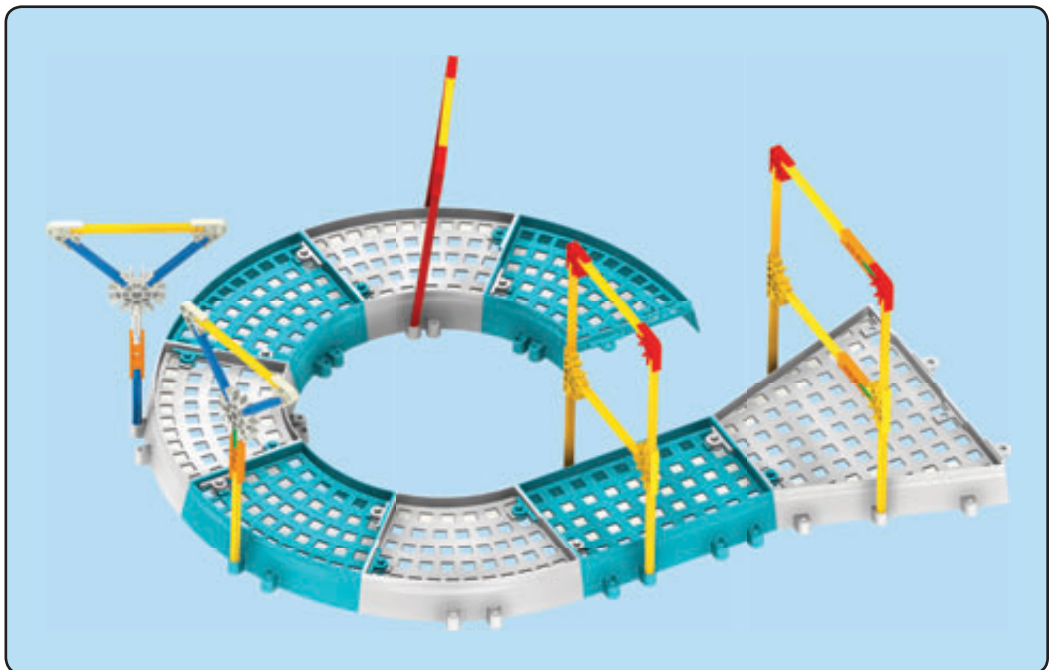

3

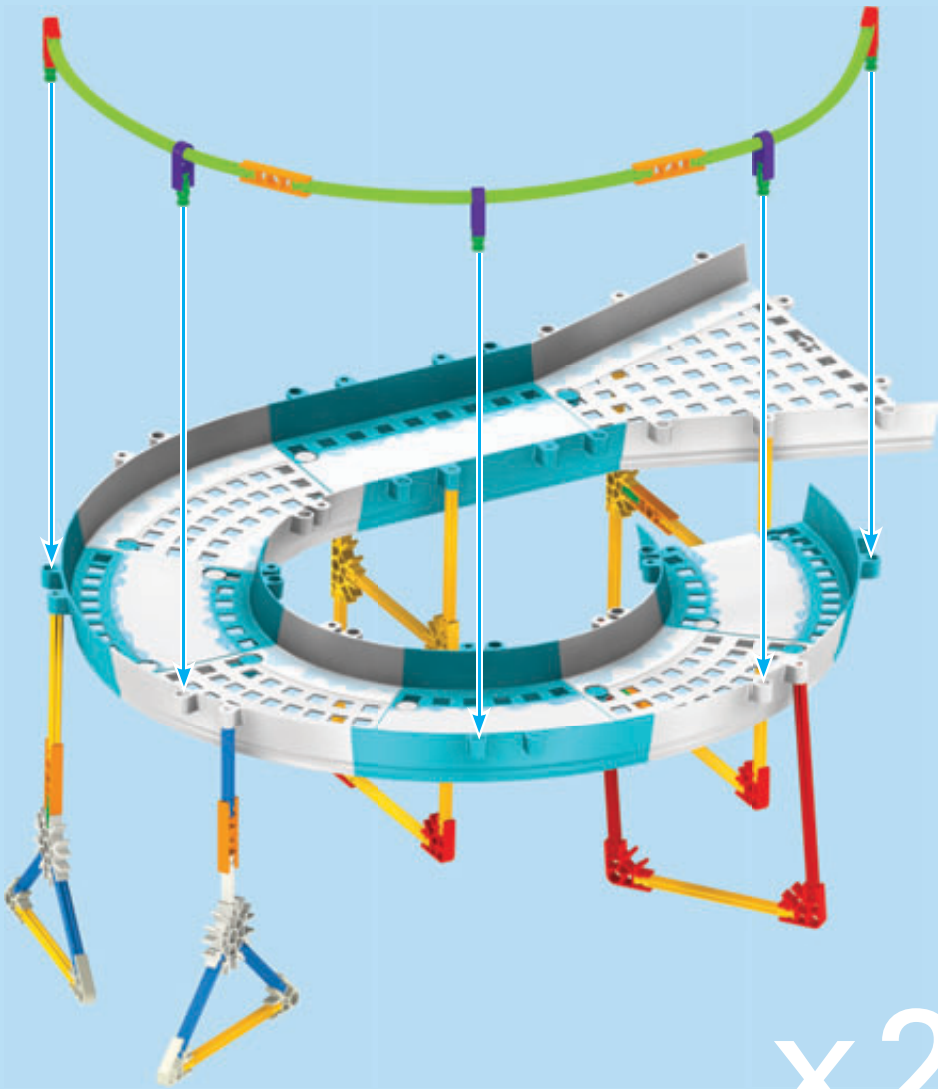

x2

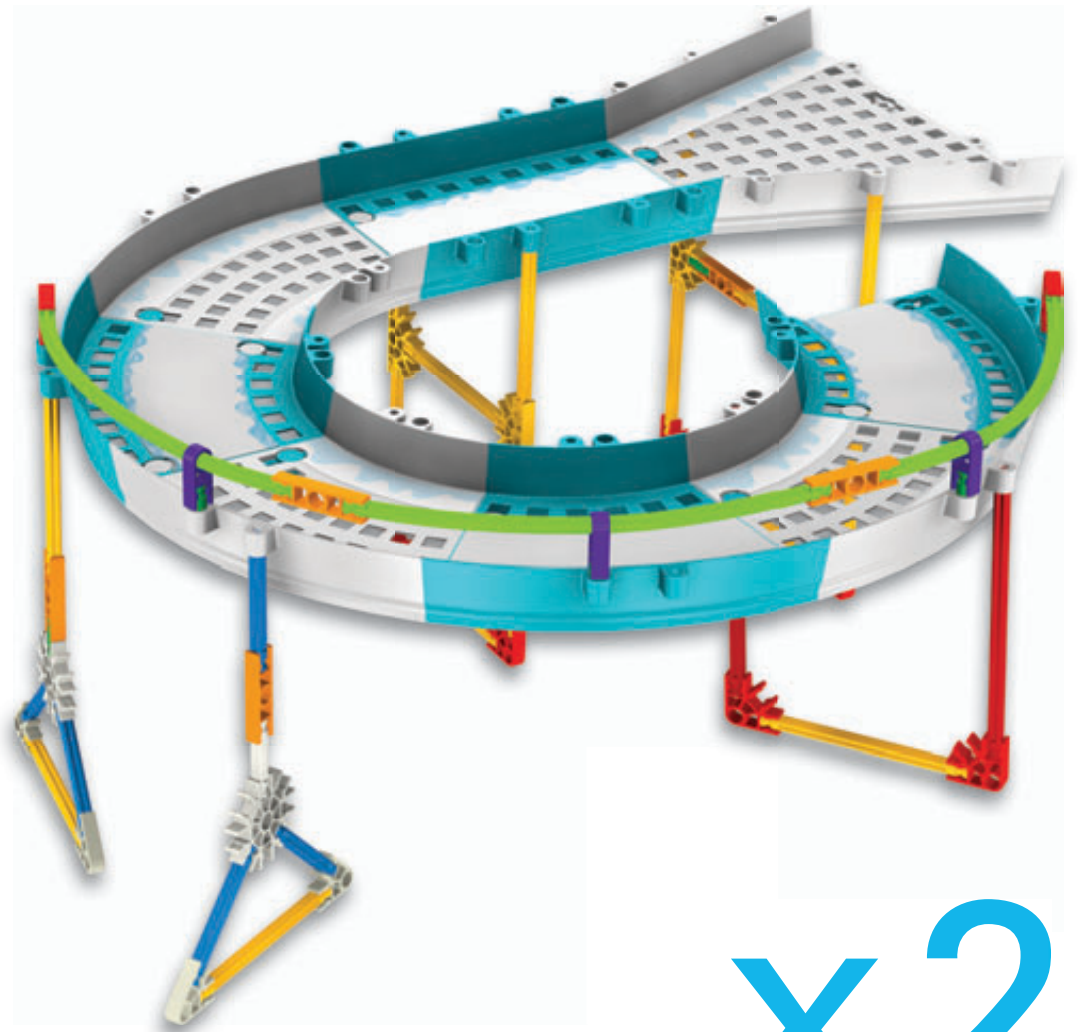

x2

1

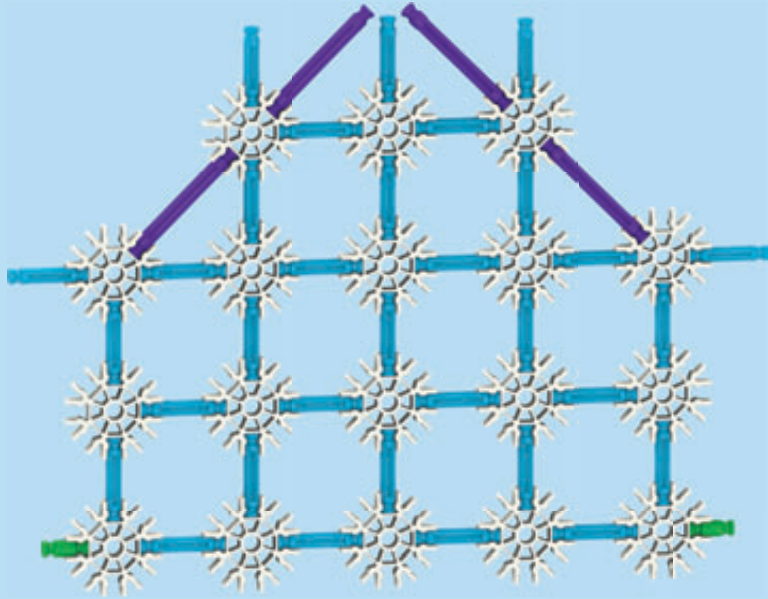

x2

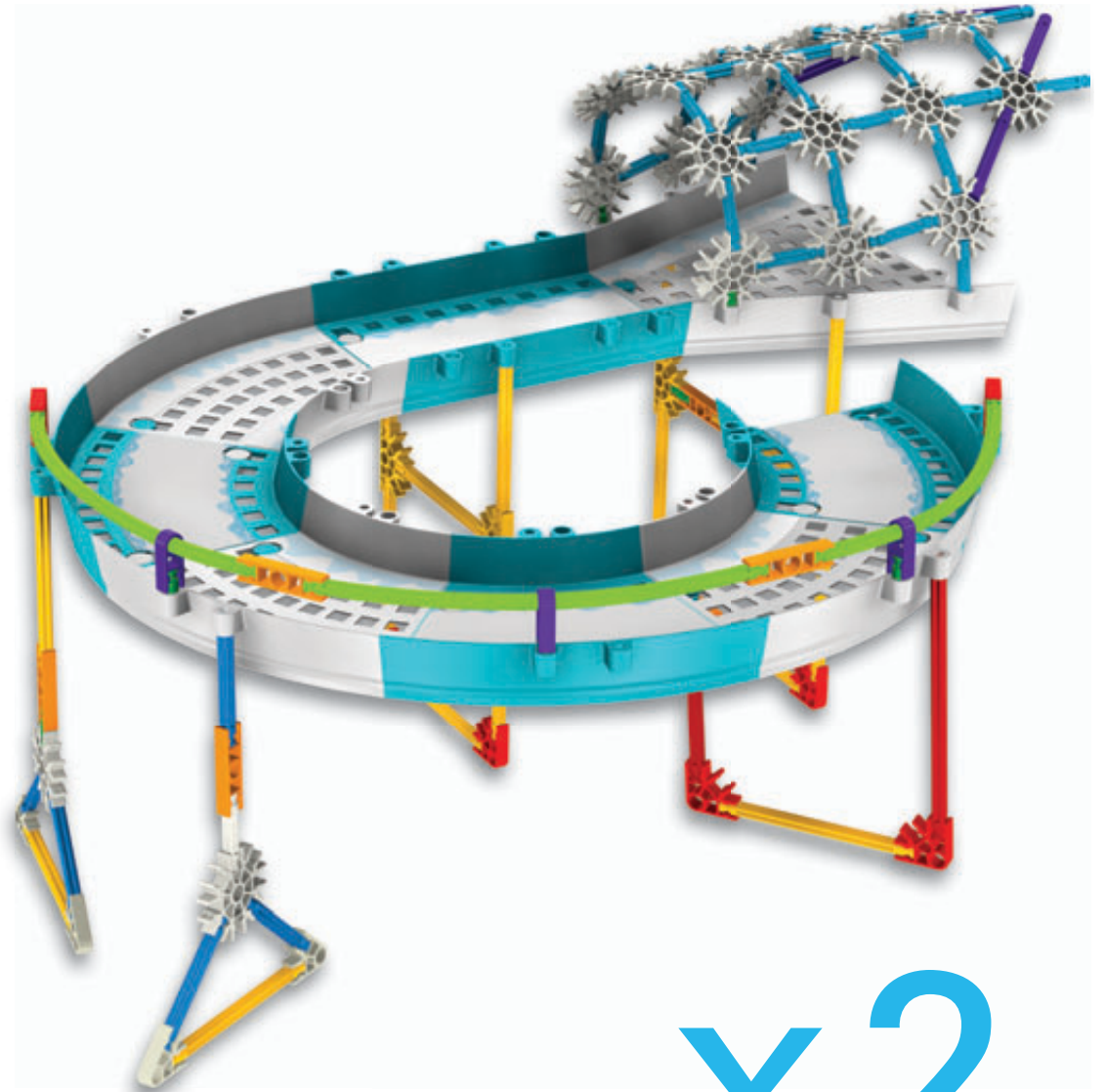

x2

2

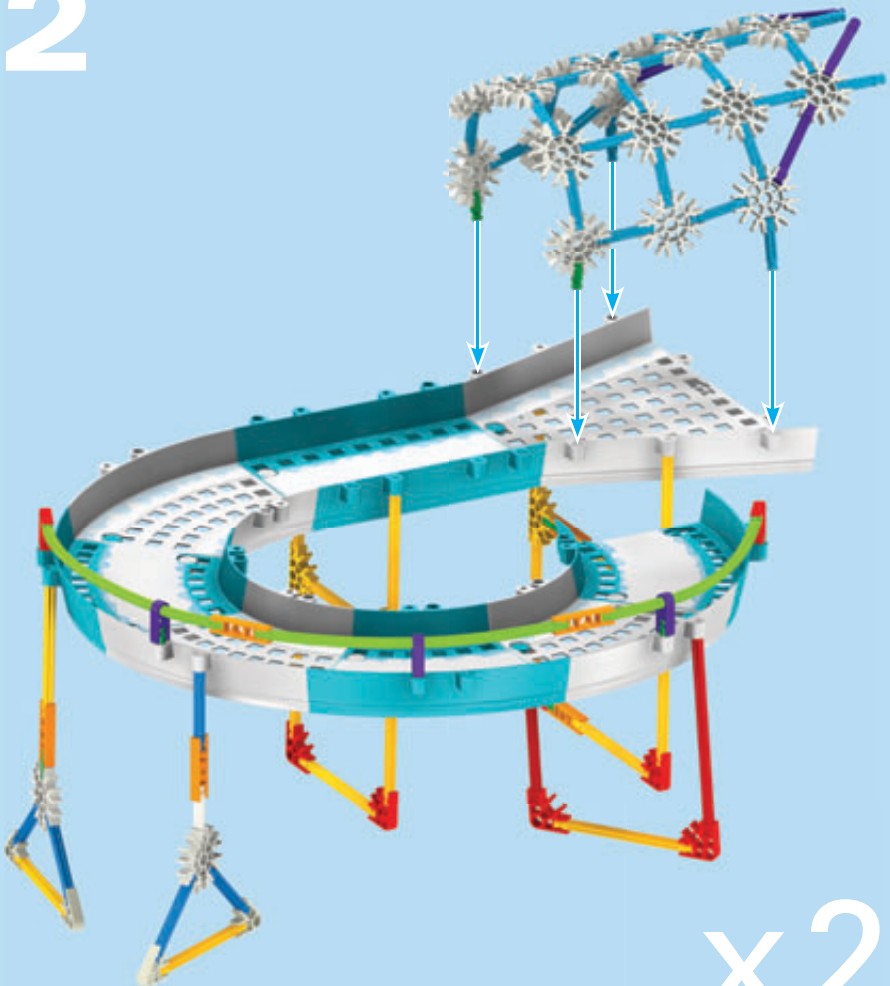

x2

3

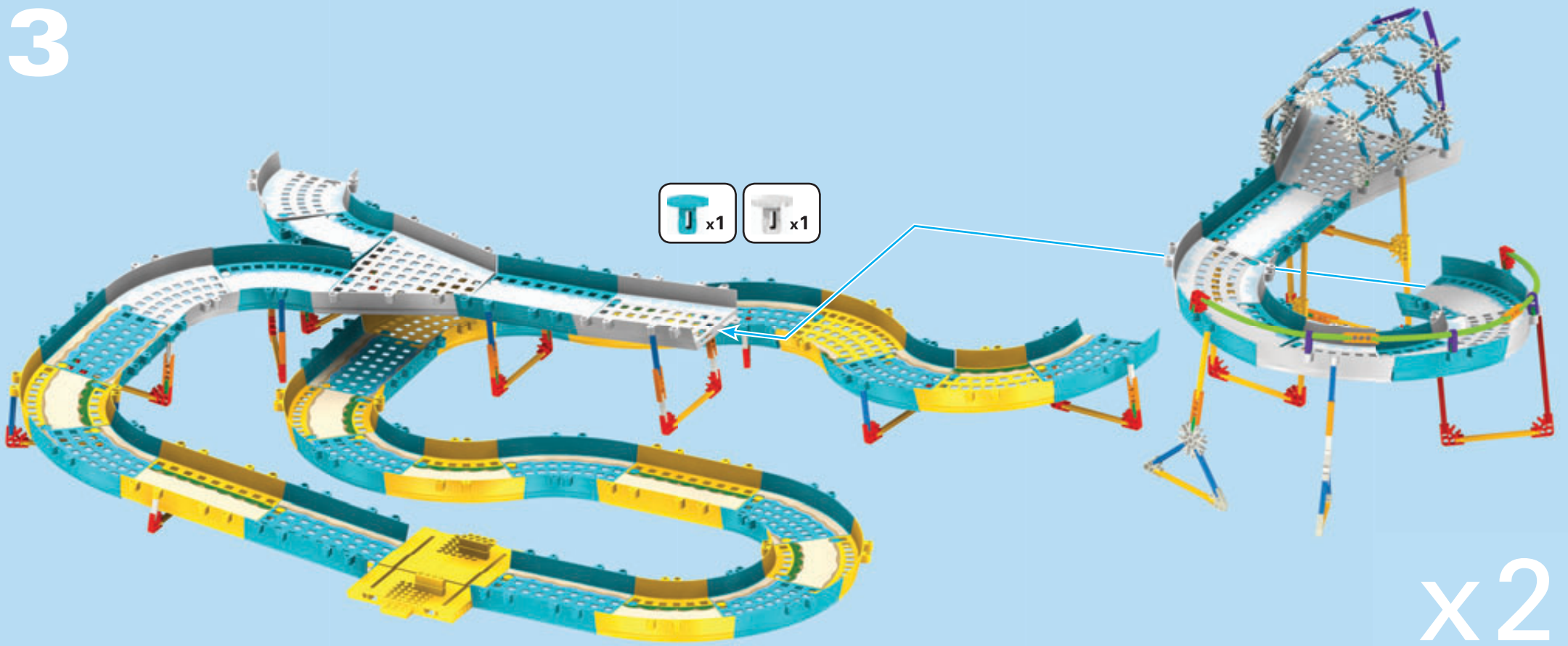

x2



x2

1

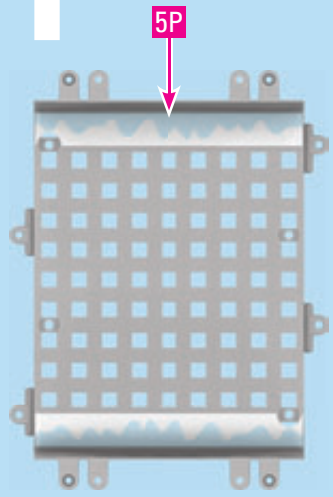

2



3

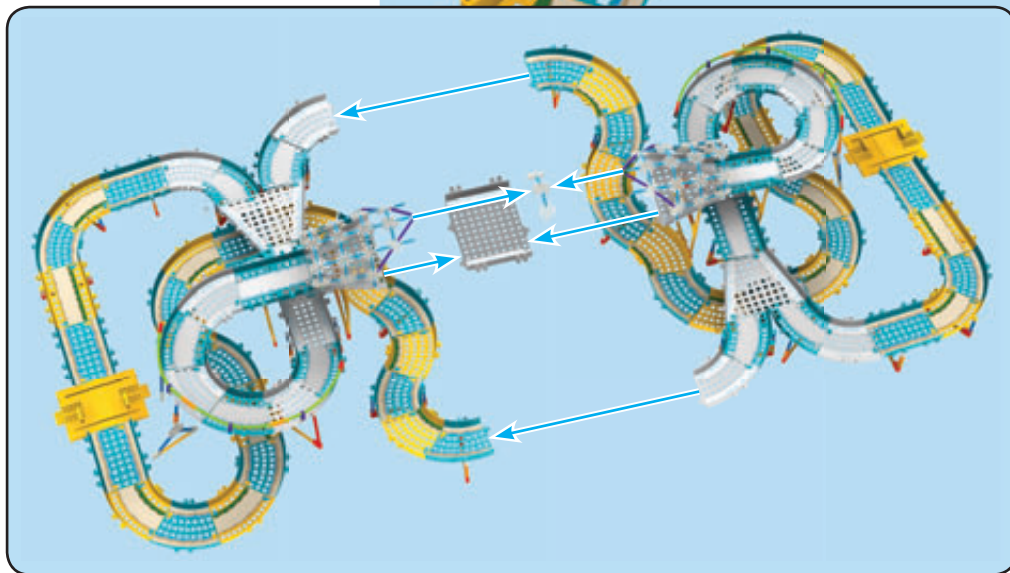
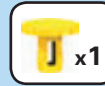
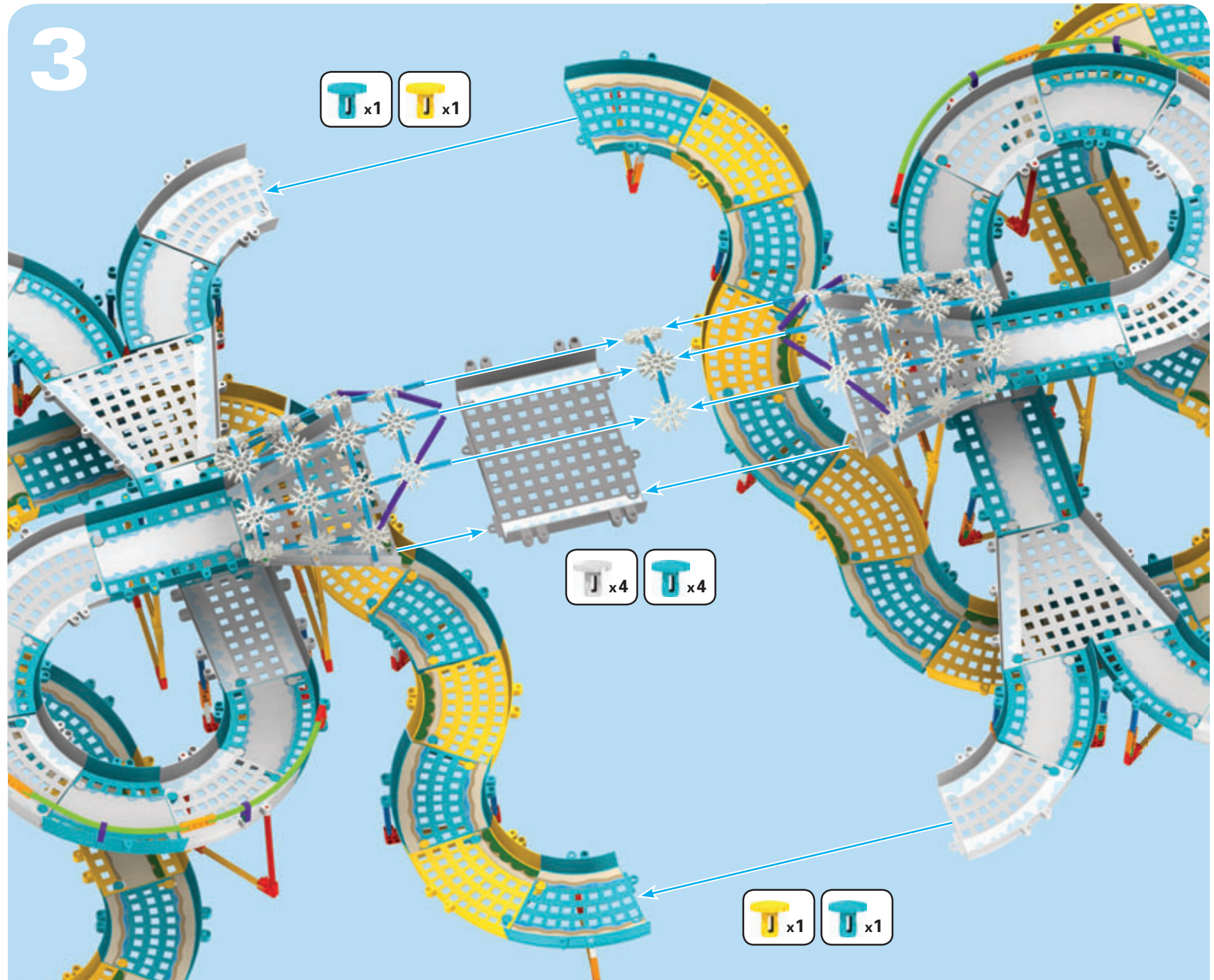

4

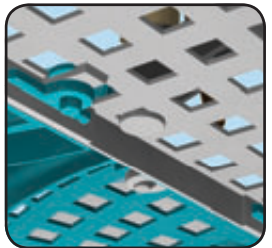
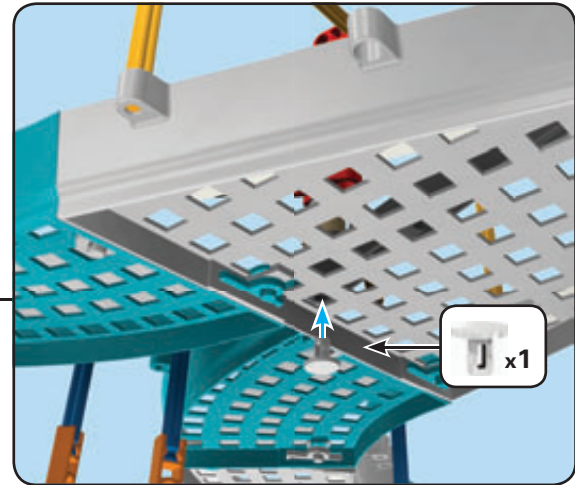
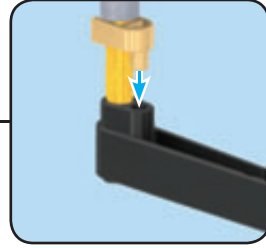
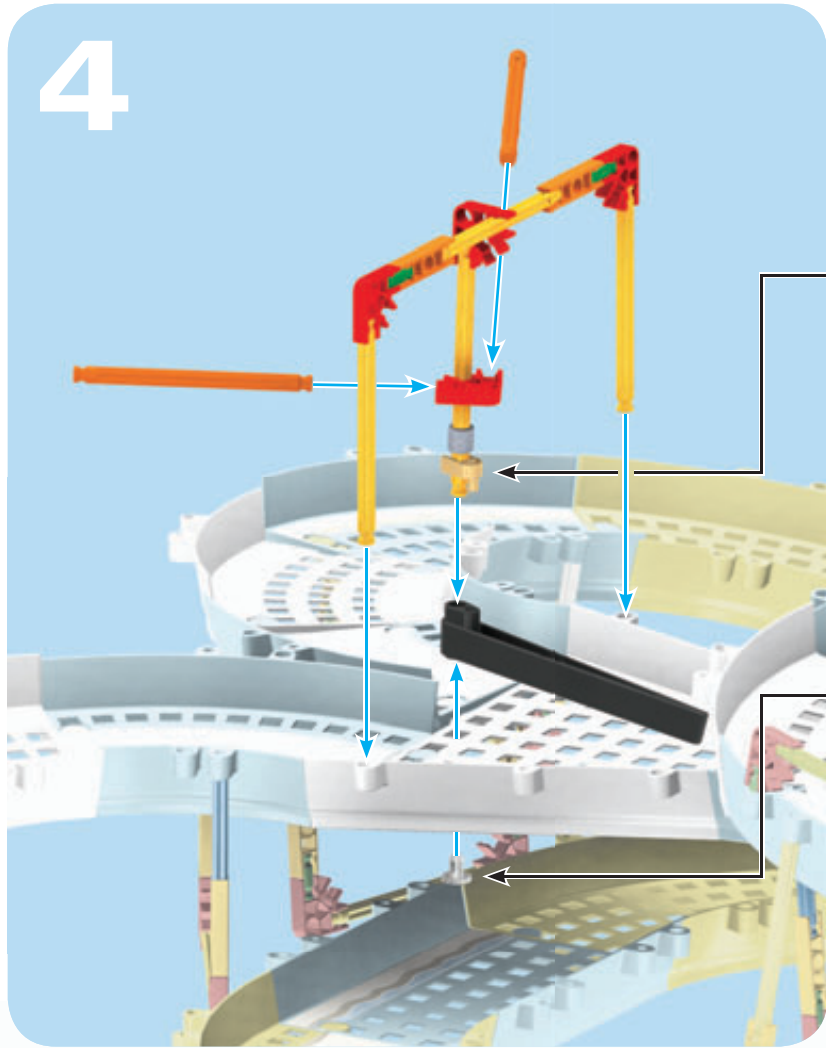

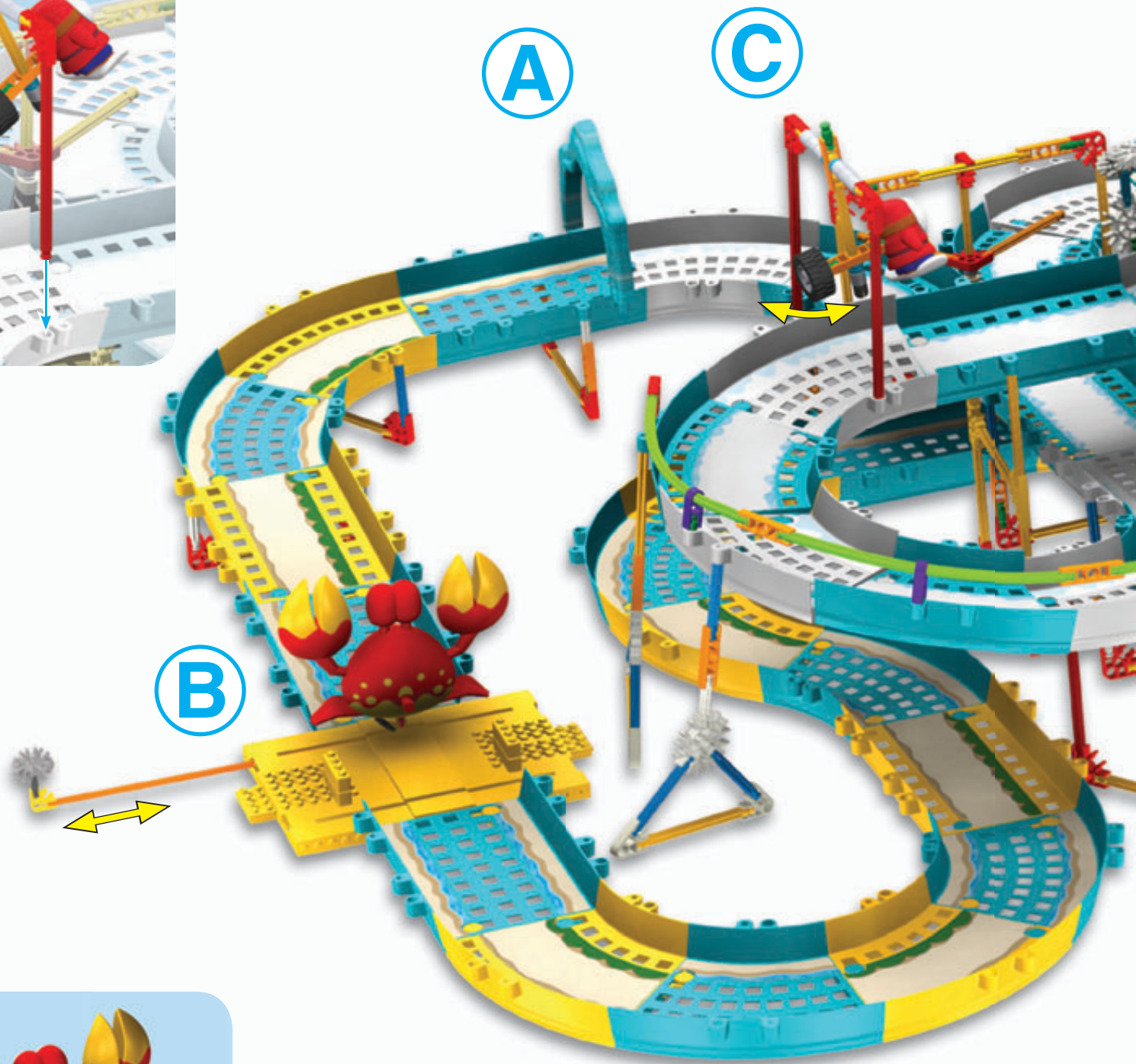
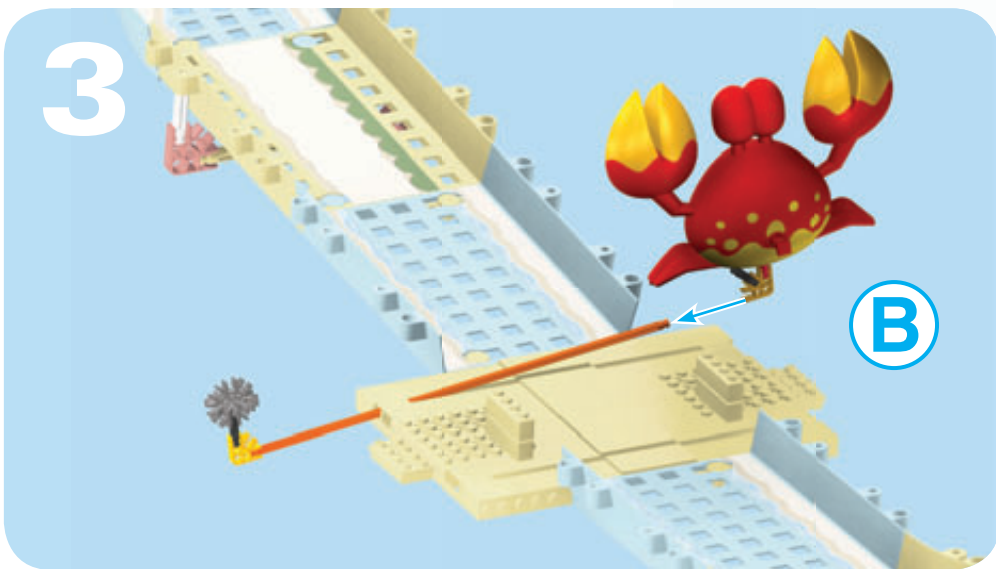
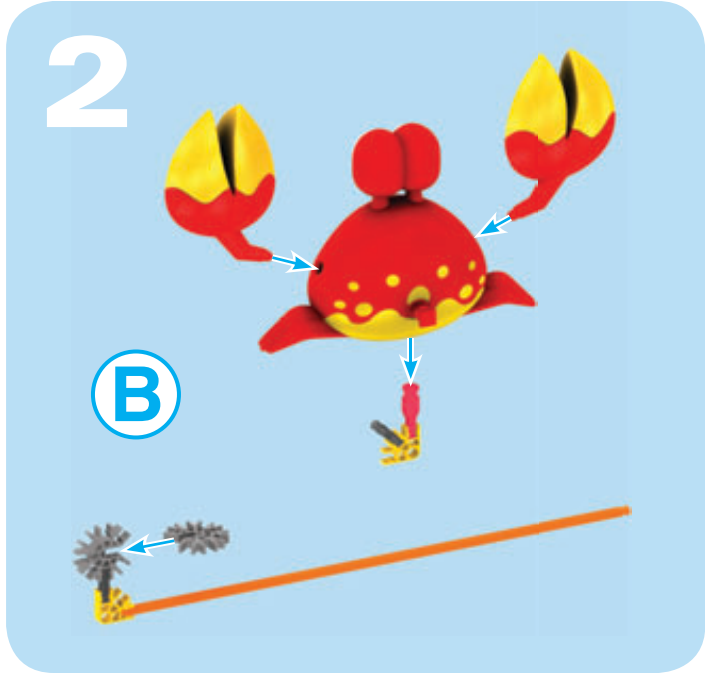
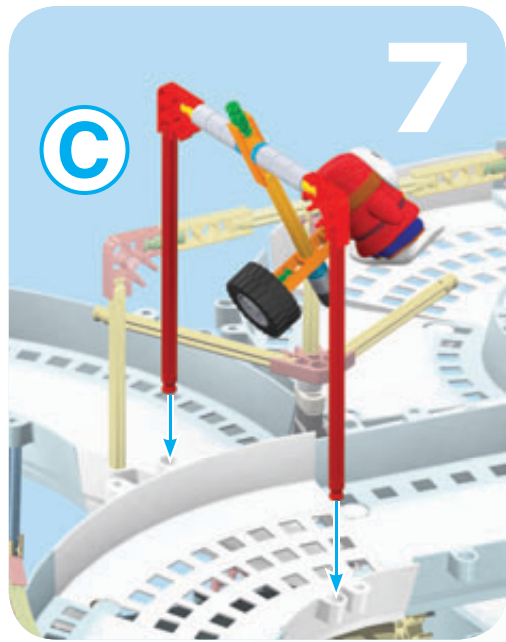
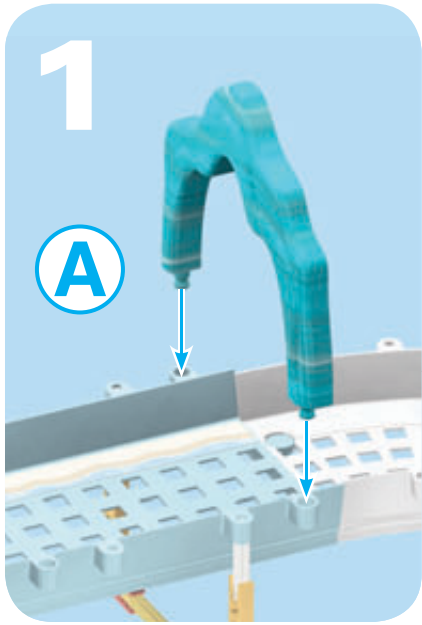

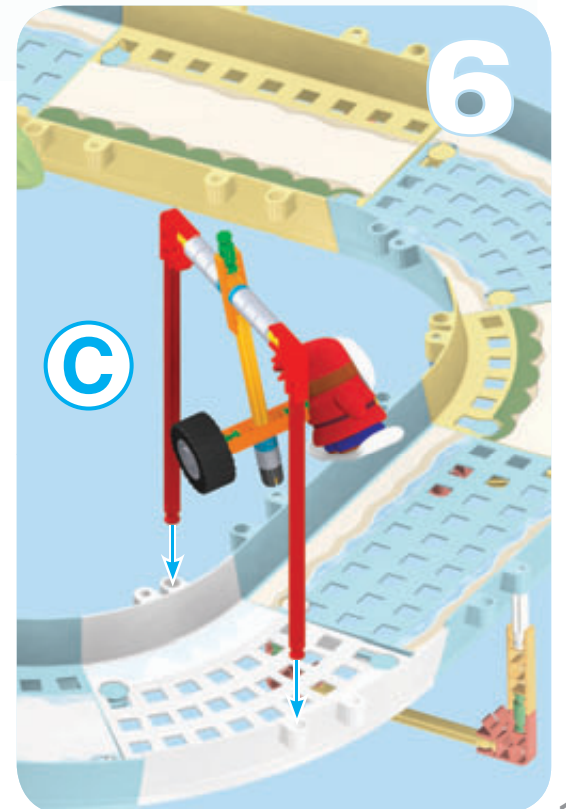
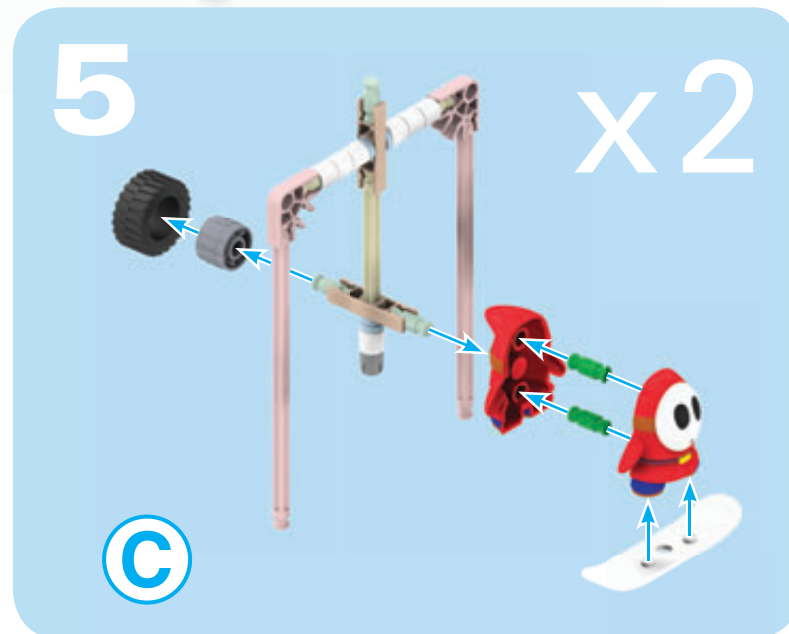
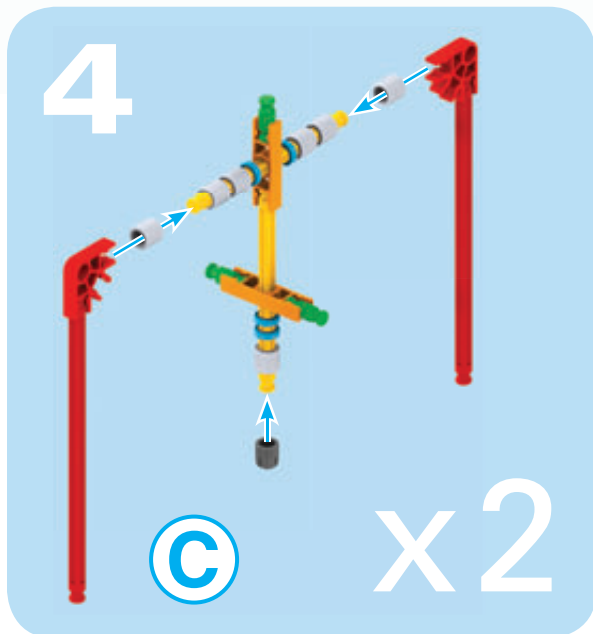
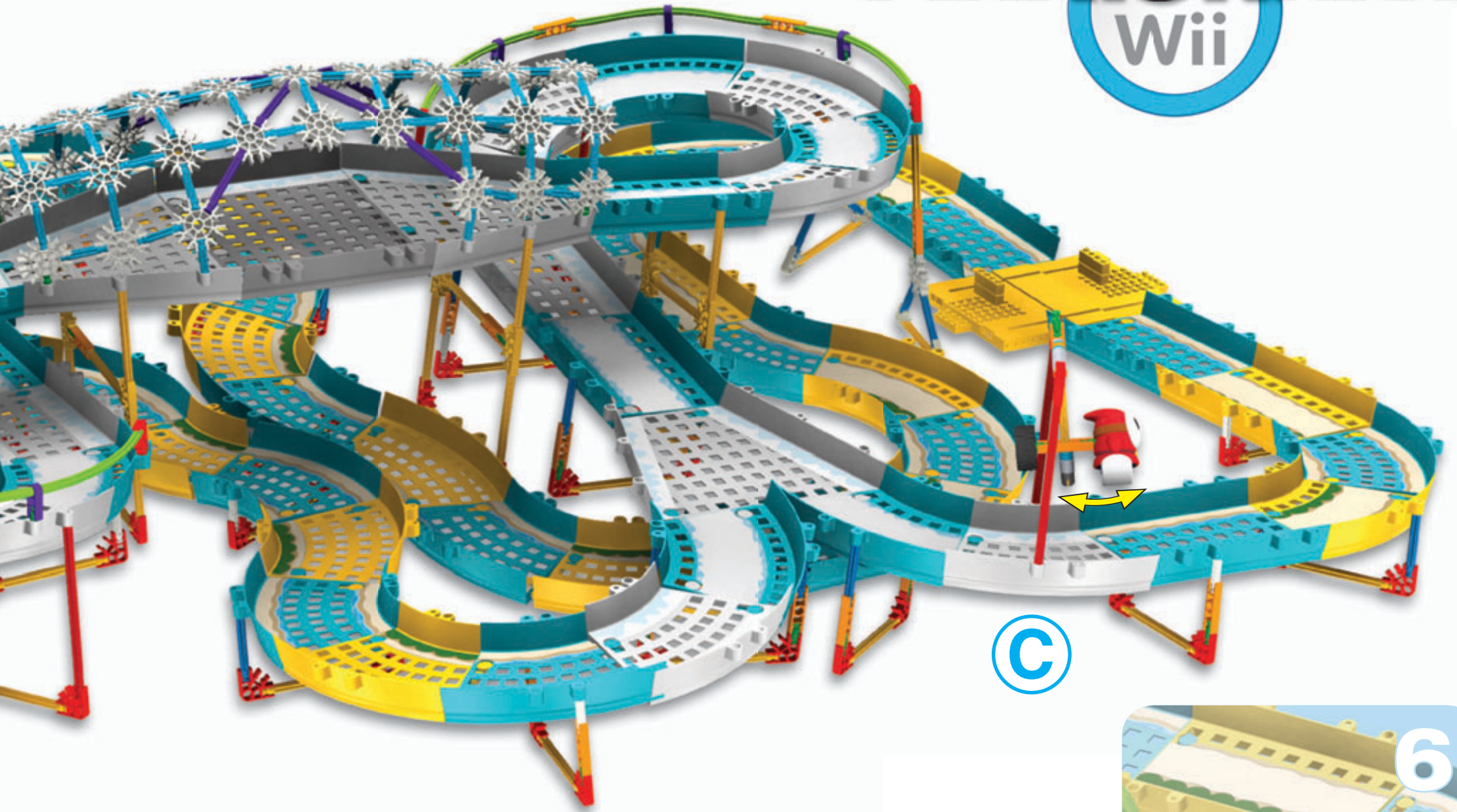

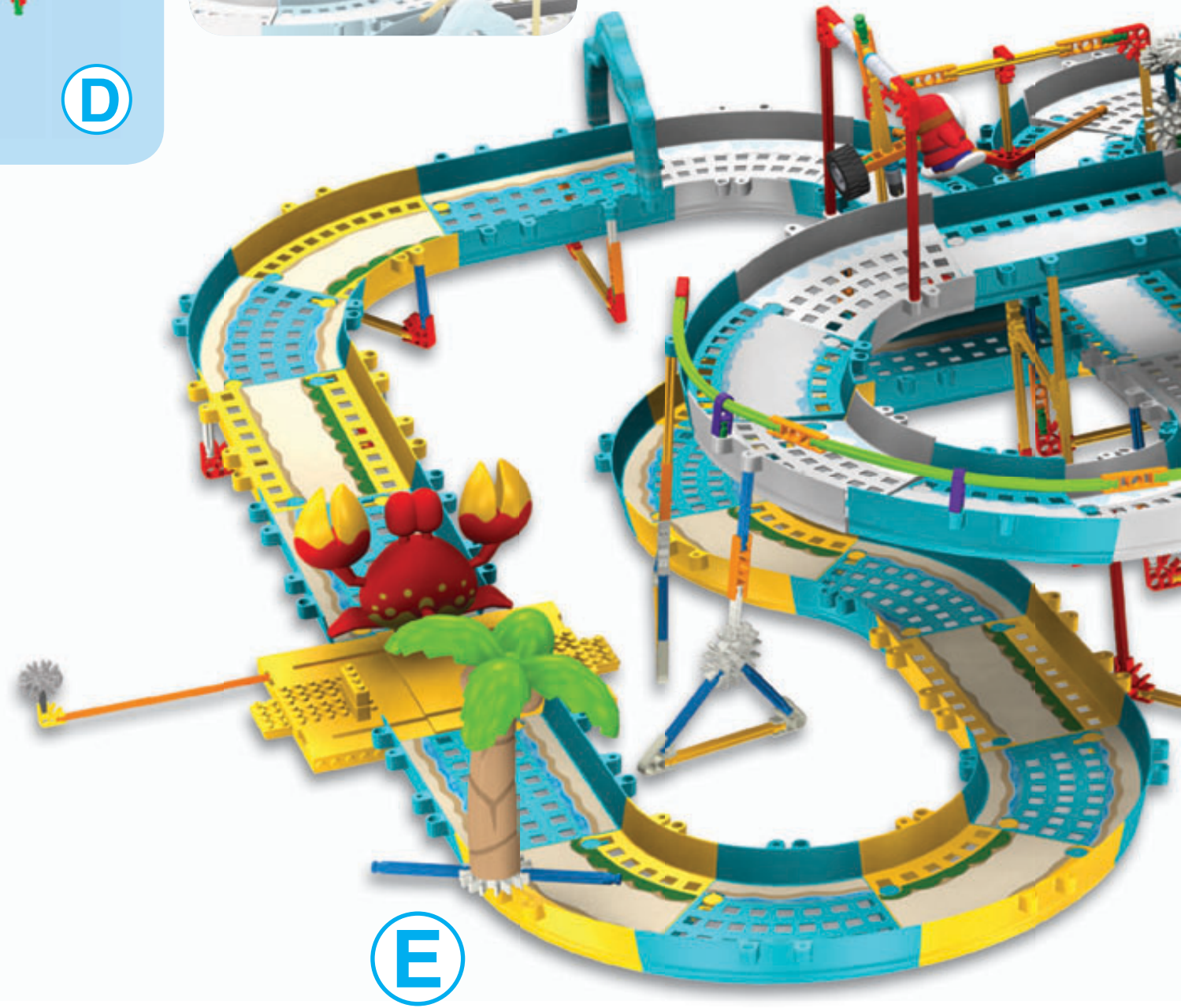
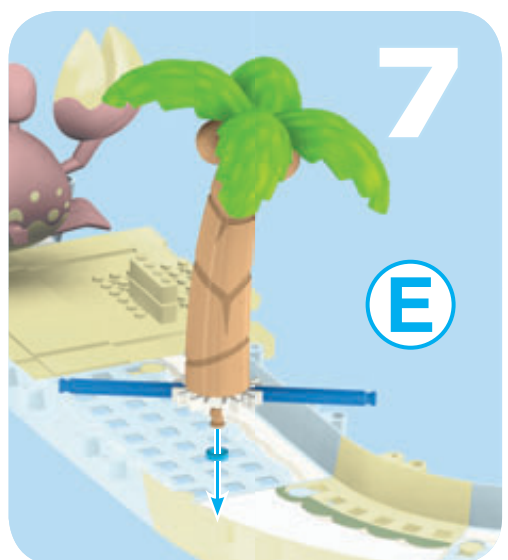
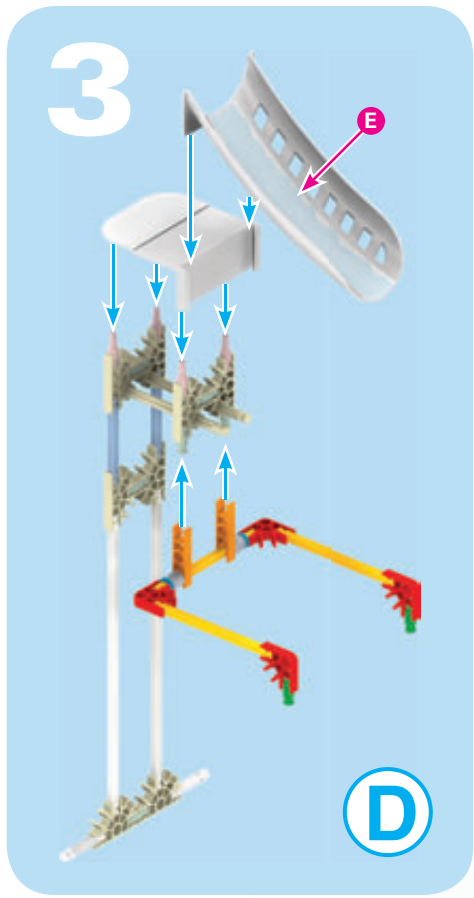
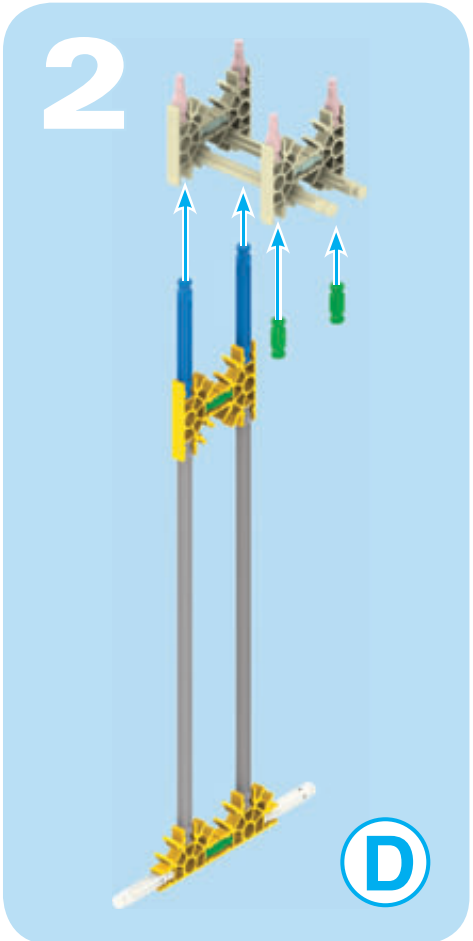
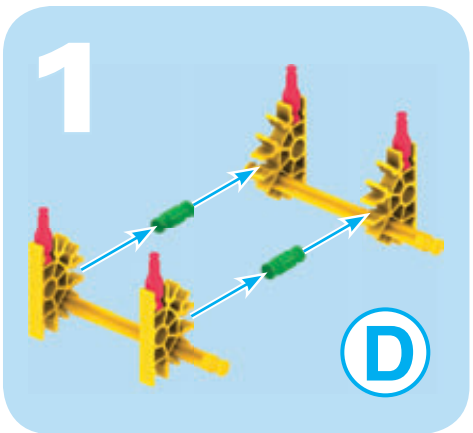

# MARIOKART™ Wii

D

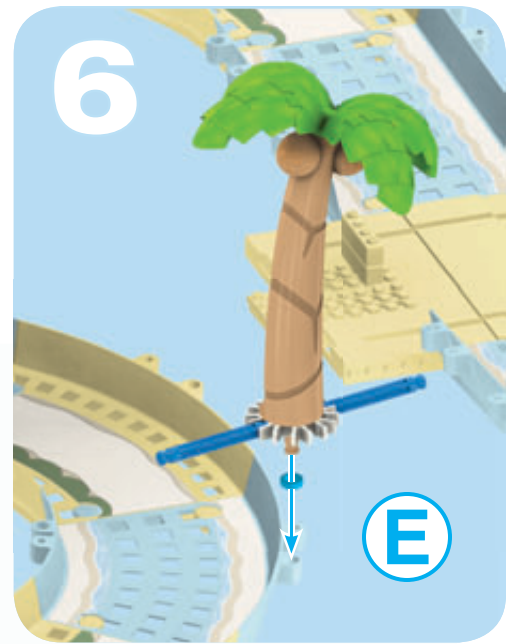
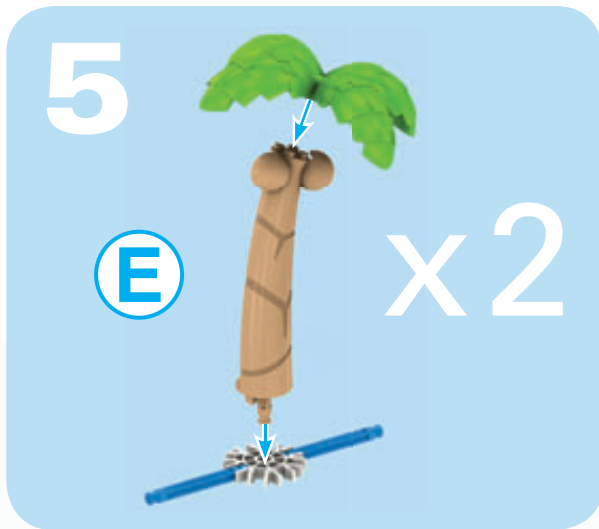
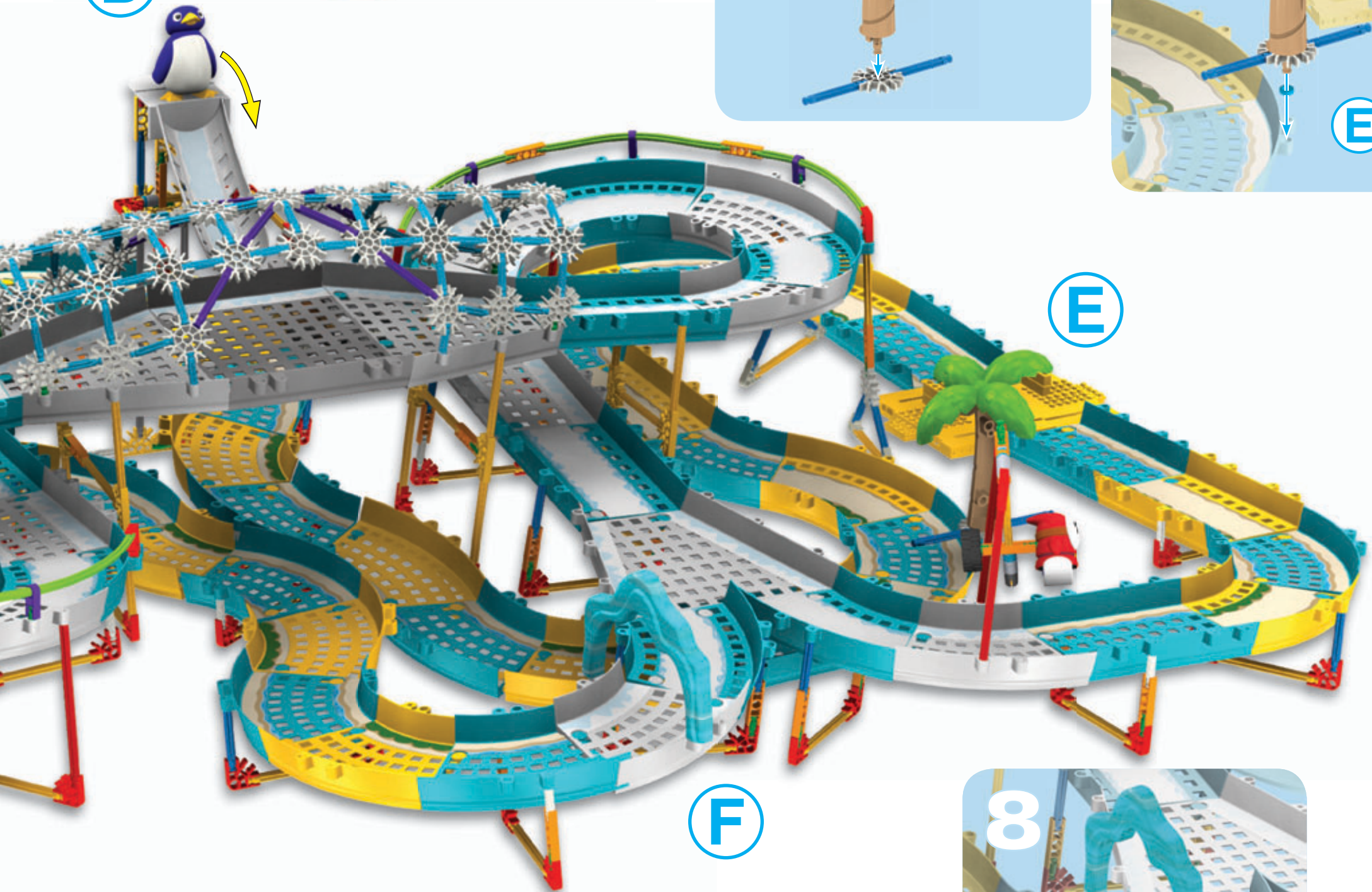

F

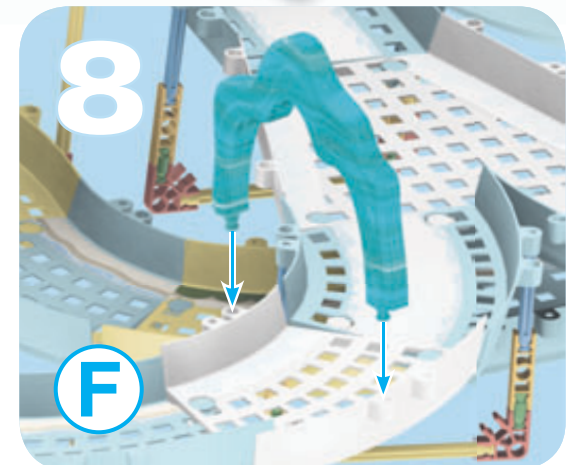

1

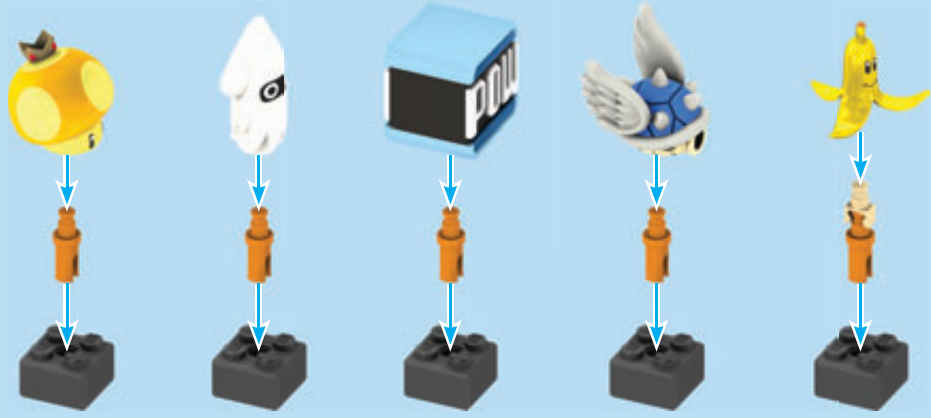

# MARIOKART™ Wii



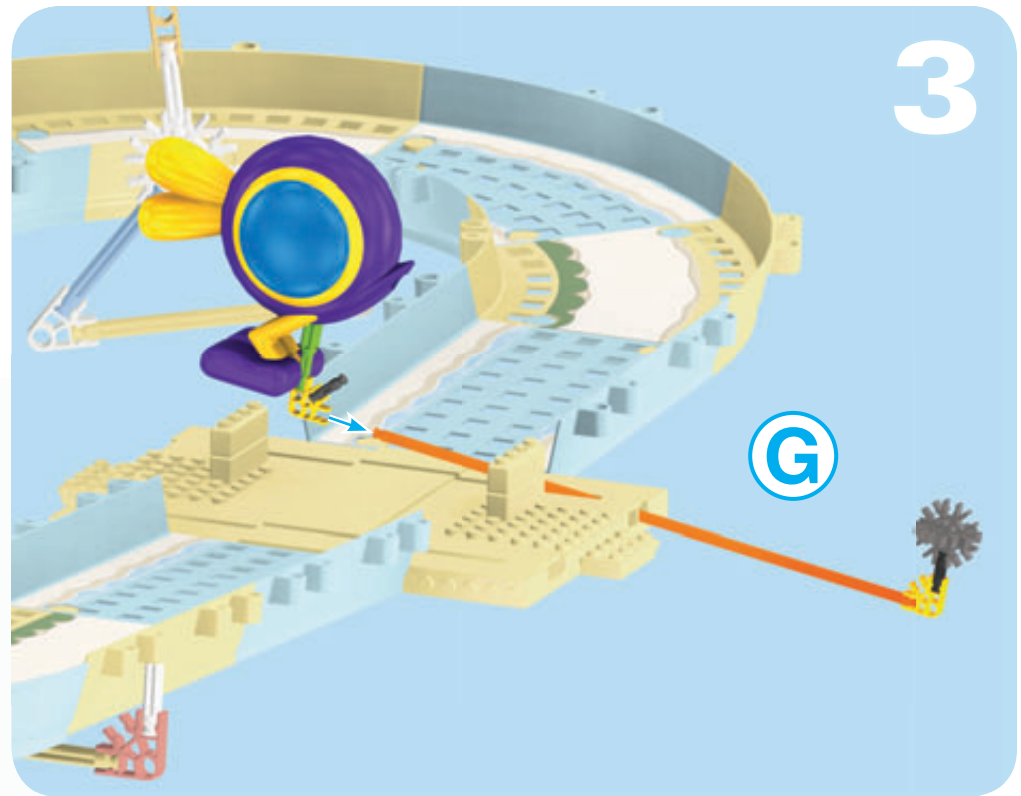
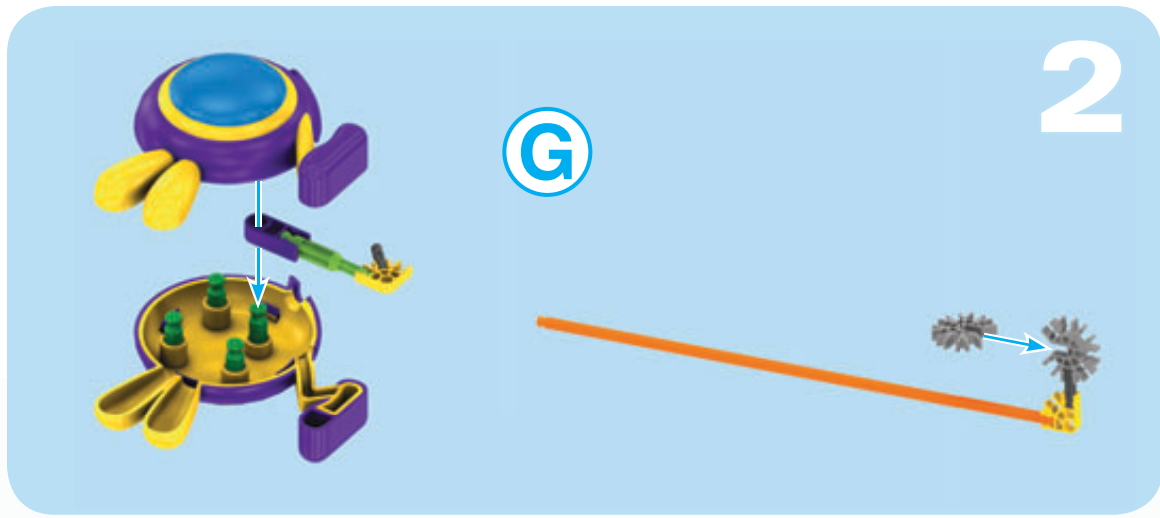



\*\* 2 Motorizadas Karts  
2 Karts Motorizadas  
2 Karts Motorizadas  
2 Gemotoriseerde Karts

• **Samle mere Mario Kart™ Wii  
Bausätze, um größere  
Strecken zu bauen!**  
• **Raccogli più Mario  
Kart™ Wii giochi di  
costruzioni per costruire  
piste più grandi!**  
• **Collez mais Mario Kart™  
Wii sets afin de  
construire des pistes  
plus grandes!**  
• **Verzamel meer Mario Kart™  
Wii gebouwen stelt te bouwen  
groter tracks!**



[www.knex.com/mariokartwii](http://www.knex.com/mariokartwii)

Collect more Mario Kart™ Wii building sets  
to build bigger tracks!

¡Recoge más Mario Kart™ Wii juegos de construcción  
para construir más grandes pistas!

Rassemblez plus d'ensembles de Mario Kart™ Wii jouets  
de construction pour faire plus grandes pistes !

\*Bild separaat. Some products may not be available in all markets.  
Se venden por separado. Algunos productos no pueden estar disponibles en todos mercados.  
Vendidos separadamente. Certains produits ne sont pas disponibles pour tous les marchés.  
Separat erhältlich. Einige Produkte können möglicherweise nicht in allen Märkten vorhanden sein.  
Venduti separatamente. Alcuni prodotti non possono essere disponibili in tutti i mercati.  
Vendidos separadamente. Algunos productos não podem estar disponíveis em todos os mercados.  
Afzonderlijk verkocht. Sommige producten kunnen niet in alle markten beschikbaar zijn.

TM & © 2012 Nintendo.



38155/  
71936\*



38064\*



38471/  
71676\*

K'NEX is a registered trademark of K'NEX Limited Partnership Group. Product & colors may vary. (ES) K'NEX es una marca registrada de K'NEX Limited Partnership Group. El producto y los colores pueden variar. (FR) K'NEX est une marques déposée de K'NEX Limited Partnership Group. Produits et couleurs peuvent varier.

©2012 K'NEX Limited Partnership Group, P.O. Box 700, Hatfield, PA 19440-0700; email@knex.com; www.knex.com; 1-800-KID-KNEX (USA/EE.UU./États-Unis/Canada). Customer outside the USA & Canada contact your local distributor at www.knex.com/distributors. (ES) El cliente que no vive en EE.UU. y Canadá se pone en contacto con el distribuidor local. Encuentre la información para el distribuidor local en www.knex.com/distributors. (FR) Le Service clients hors États-Unis et Canada, s'il vous plaît contacter le distributeur local. L'information de distributeur peut être trouvée à www.knex.com/distributors. (DE)(FR)(NL)(UK) www.tomy.eu. (UK) TOMY Careline, PO Box 20, Totton, Hants, SO40 3YF, England; Tel 023 8066 2600. (FR) ALLO TOMY SAV, Parc d'affaires international, 74166 ARCHAMPS, France ; Tél 0 820 013 013.

- Identifies Genuine K'NEX Bricks.
- Identifica los ladrillos genuinos de K'NEX.
- Identifie que ce sont d'authentiques briques K'NEX.
- Identifiziert echte K'NEX-Bausteine.
- Edentifica i veri blocchi K'NEX.
- Identifica que são cubos genuinos da K'NEX.
- Identificeert K'NEX bakstenen voor.

facebook.com/buildknex

KNEX.COM

138565-V1-05/12

