

K'NEX

Building Worlds Kids Love

SUPER MARIO 3D WORLD



CAT MARIO™
BUILDING SET

MARIO CHAT
JEU DE CONSTRUCTION

KATZE MARIO
BAUSATZ

KAT MARIO
BOUWSET

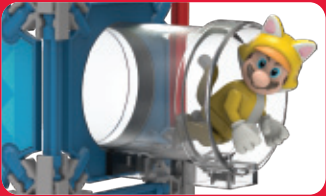

CLEAR WARP PIPE!
TUYAU TRANSLUCIDE !
DURCHSICHTIGE WARP-RÖHRE!
TRANSPARANTE WARPBUIS!‡

LIMITED EDITION!
ÉDITION LIMITÉE !
LIMITED EDITION!
BEPERKTE UITGAVE!‡



CAT MARIO™
MARIO CHAT



MOUSE
SOURIS



8+

38635/38635 ML



SUPER MARIO 3D WORLD

CAT MARIO™
 BUILDING SET
MARIO CHAT
 JEU DE CONSTRUCTION
KATZE MARIO
 BAUSATZ
KAT MARIO
 BOUWSET



1		1		4		1	
8		1		13		1	
2		4		27		1	
5		2		1		5	
23		12		1		1	
8		2		39		1	
26		2		6		2	
4		5					
1							

1		1		1	
1		1		1	
1		1		1	
1		1		1	
				1	

1

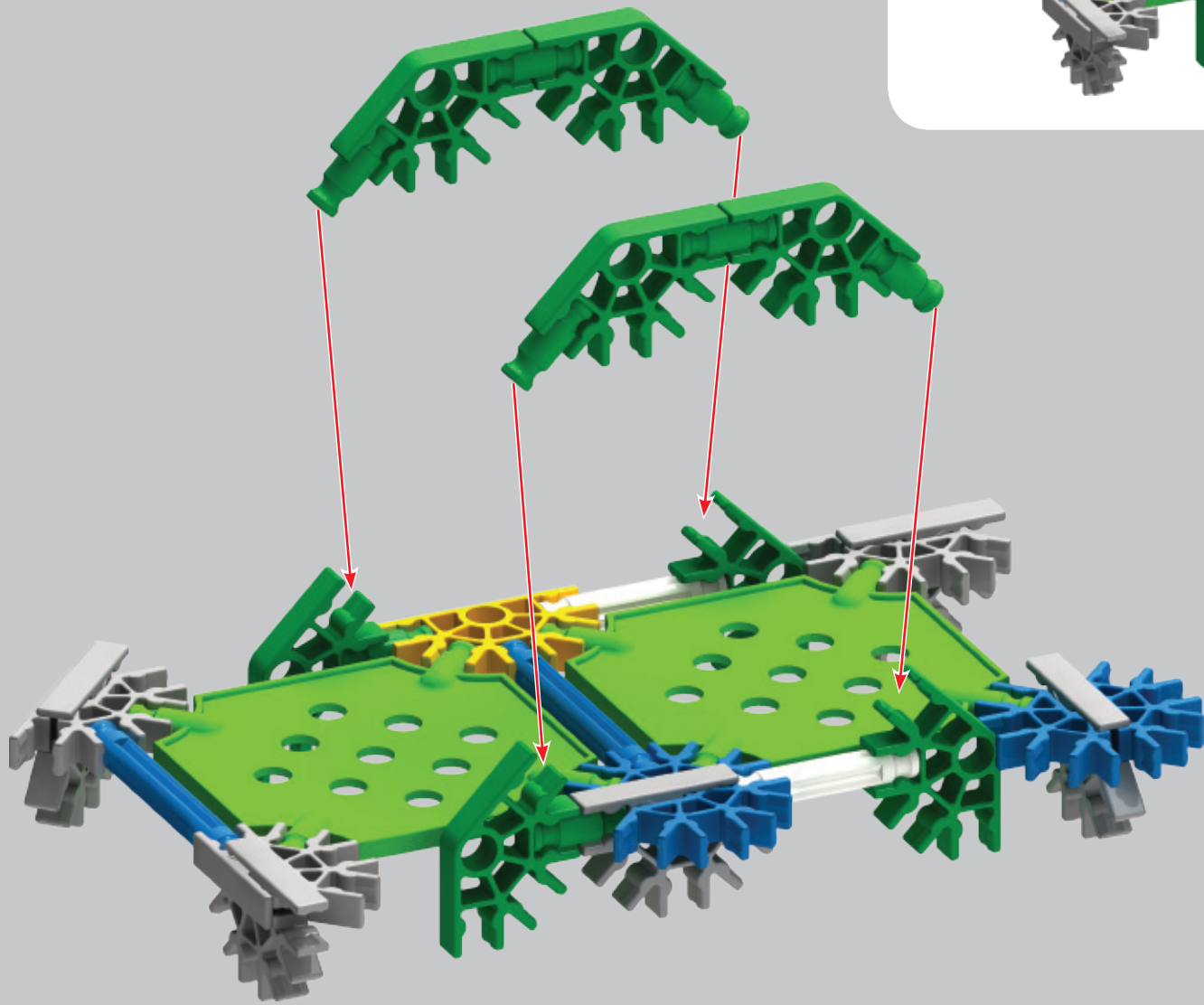
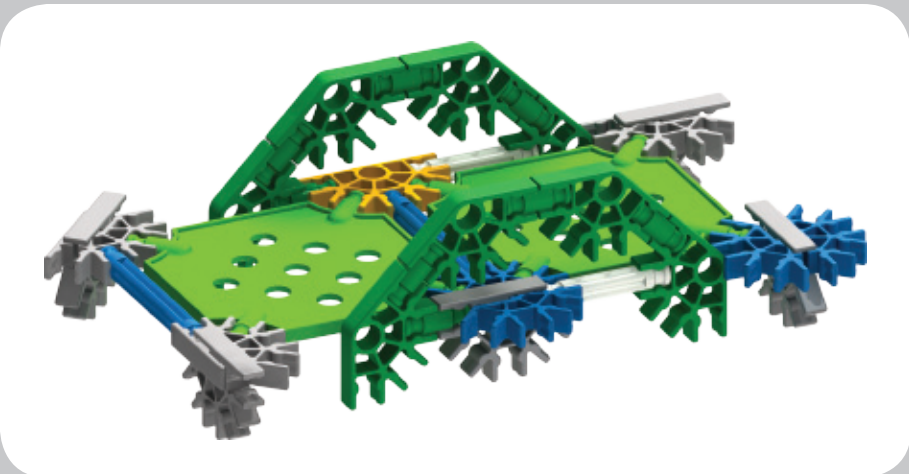

2

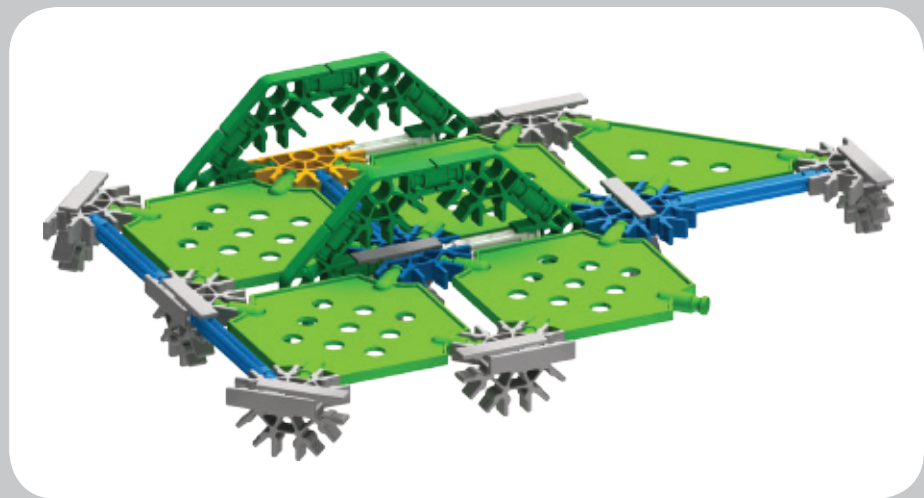
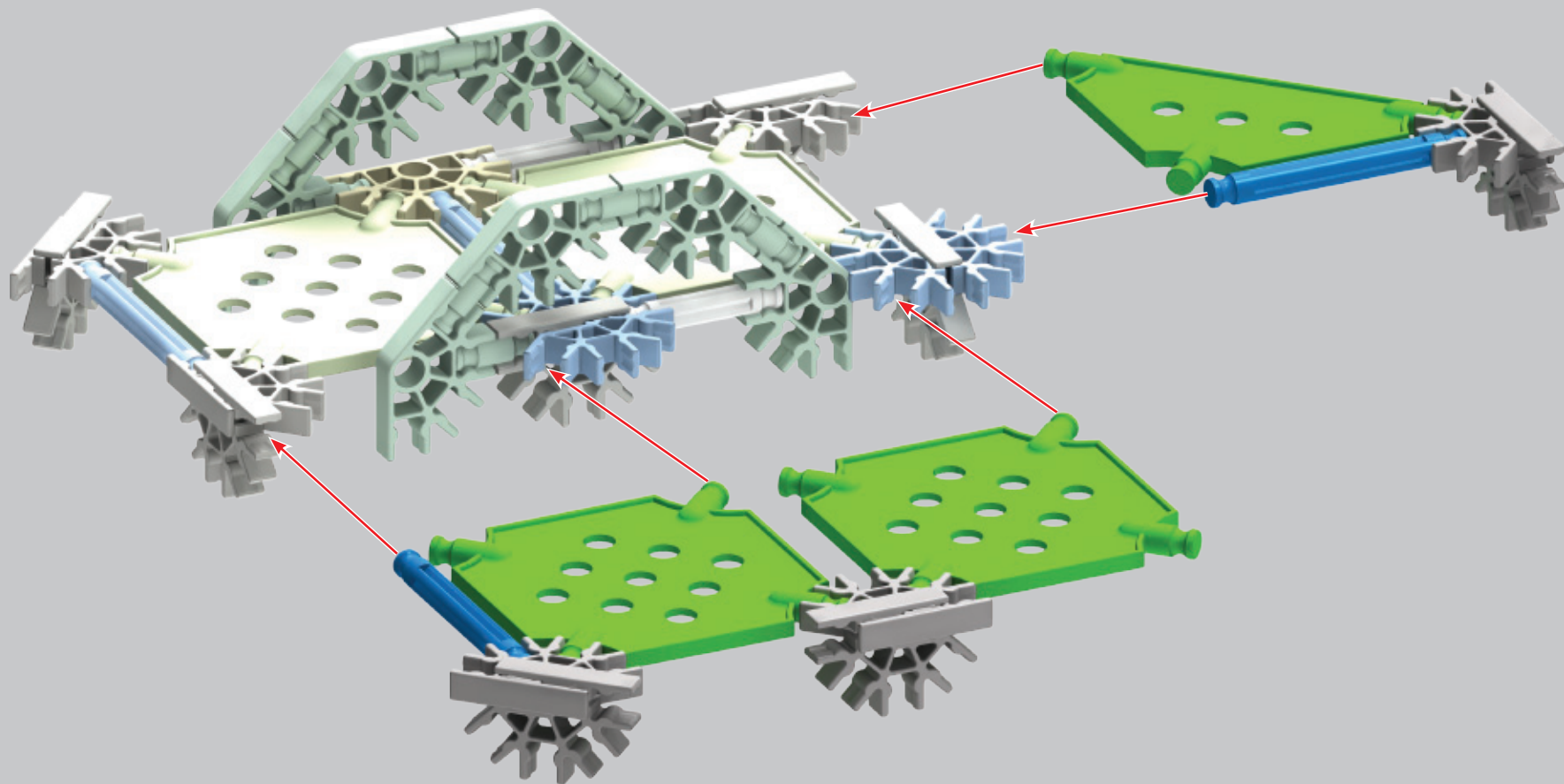

3

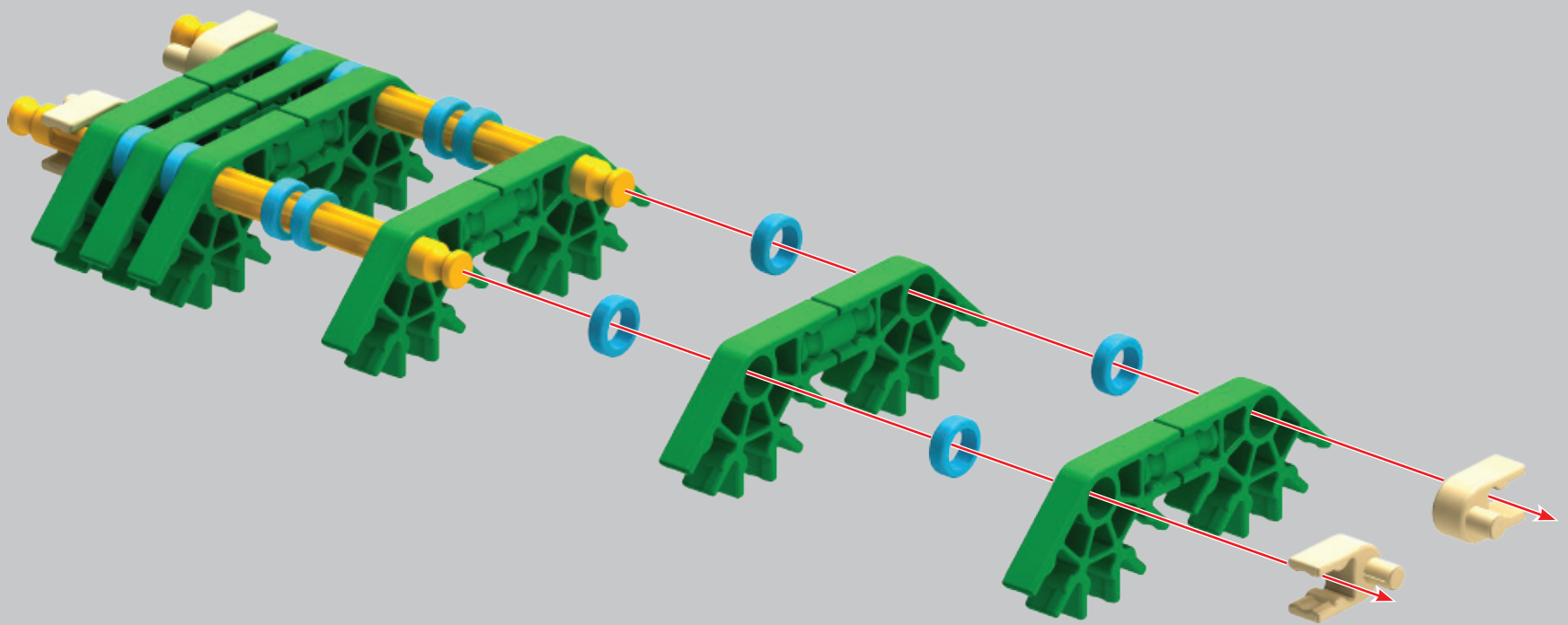
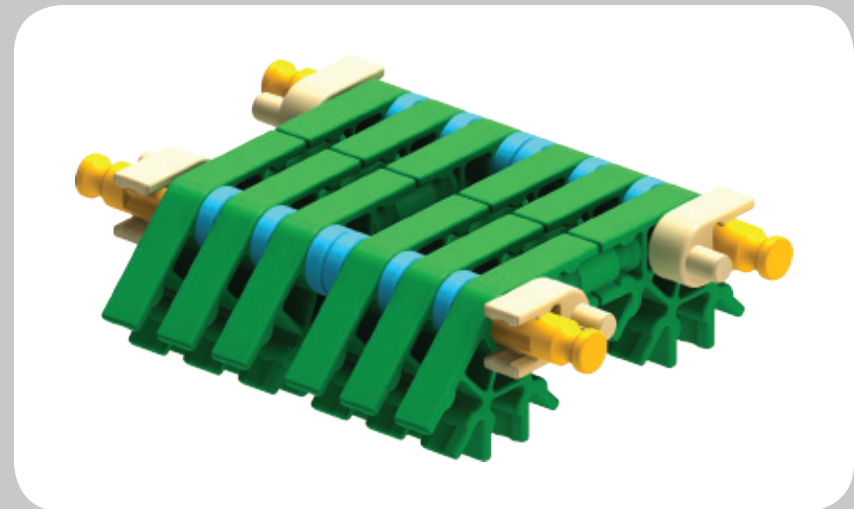

4

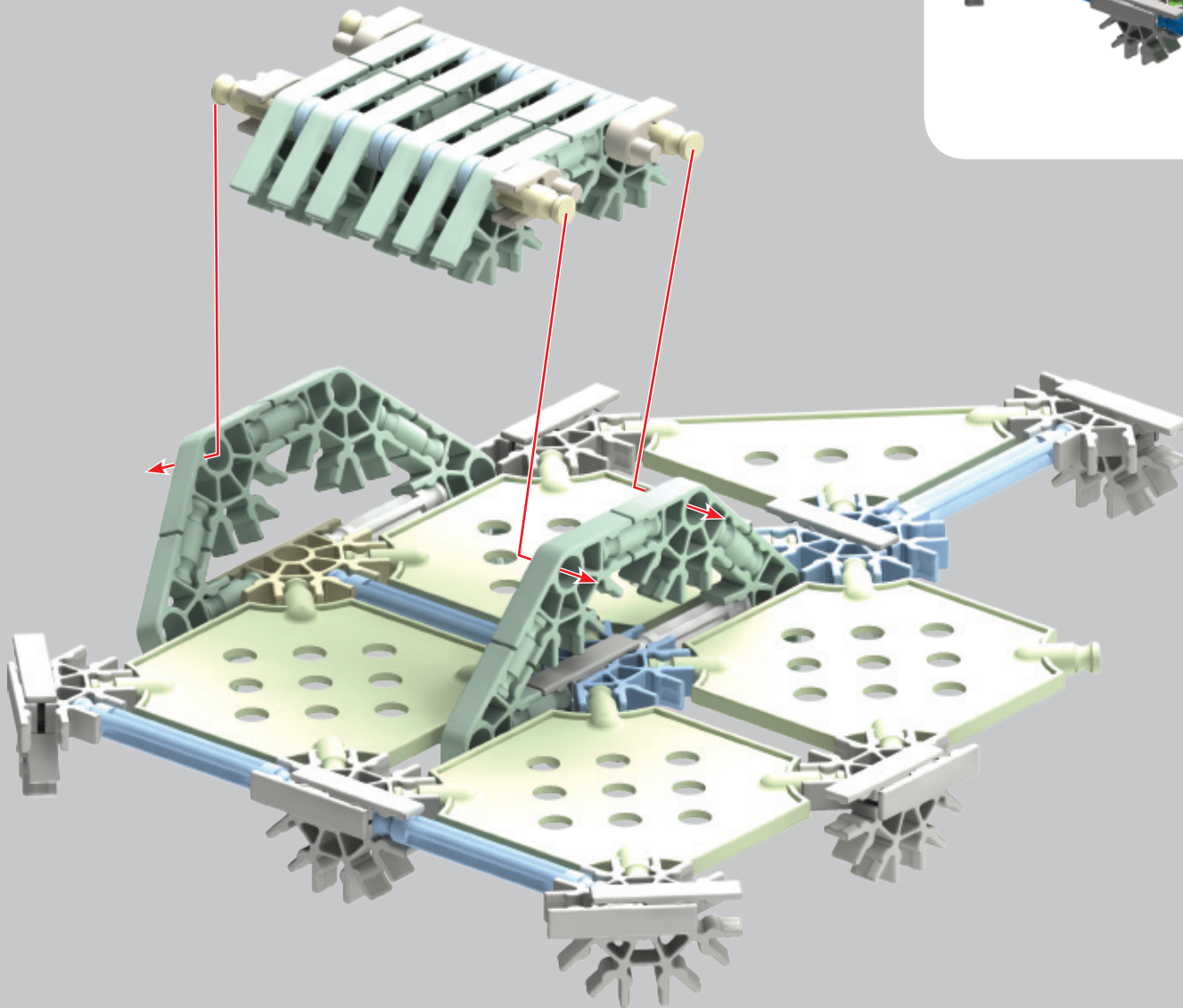

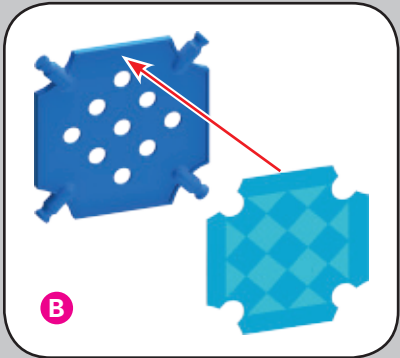
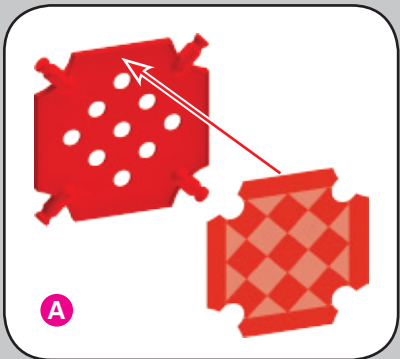
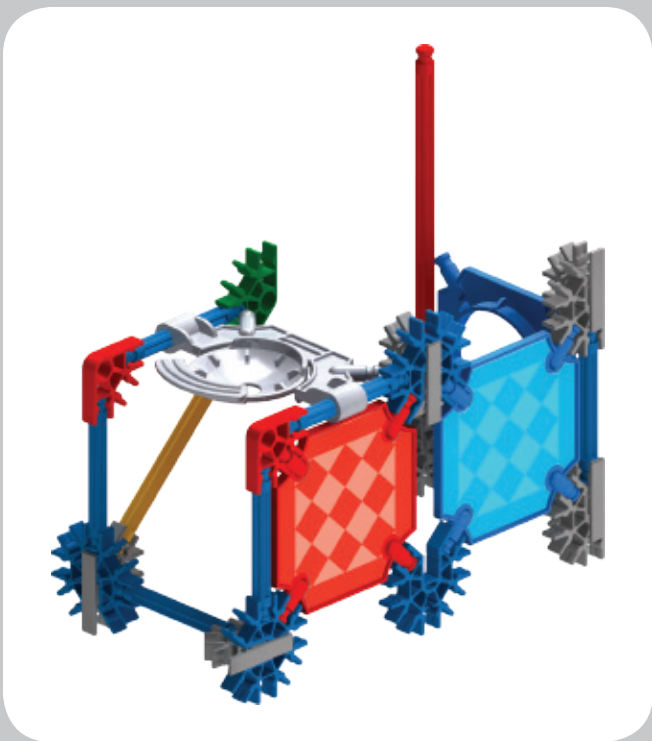

Apply stickers.
 Appelez des autocollants.
 Aplicar pegatinas.
 Bringe die Aufkleber an.
 Applicare gli adesivi.
 Aplicar adhesivos.
 Stickers plakken.

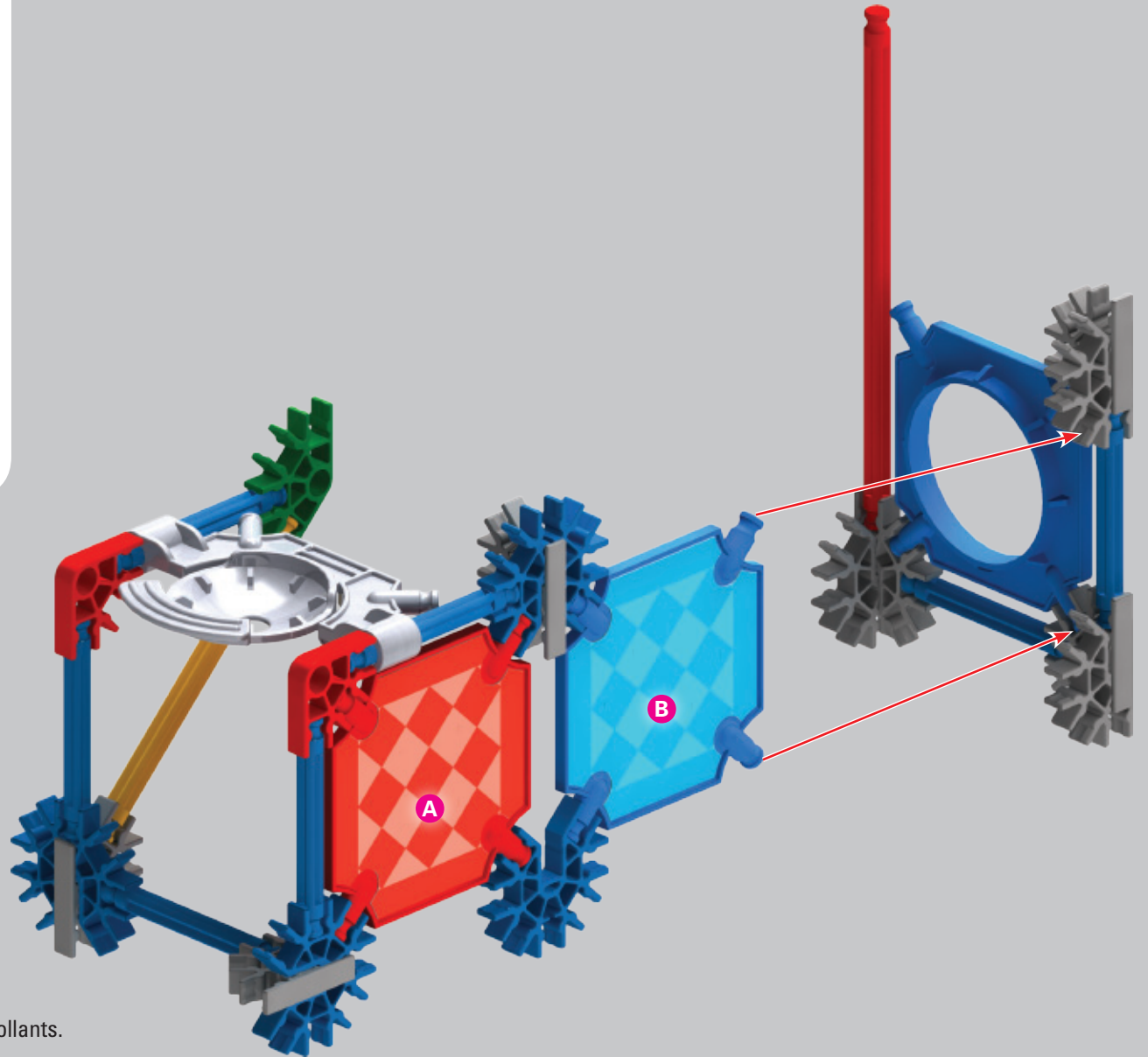

6

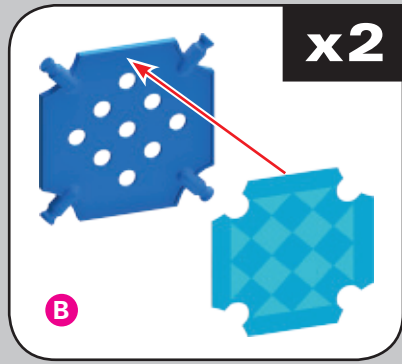
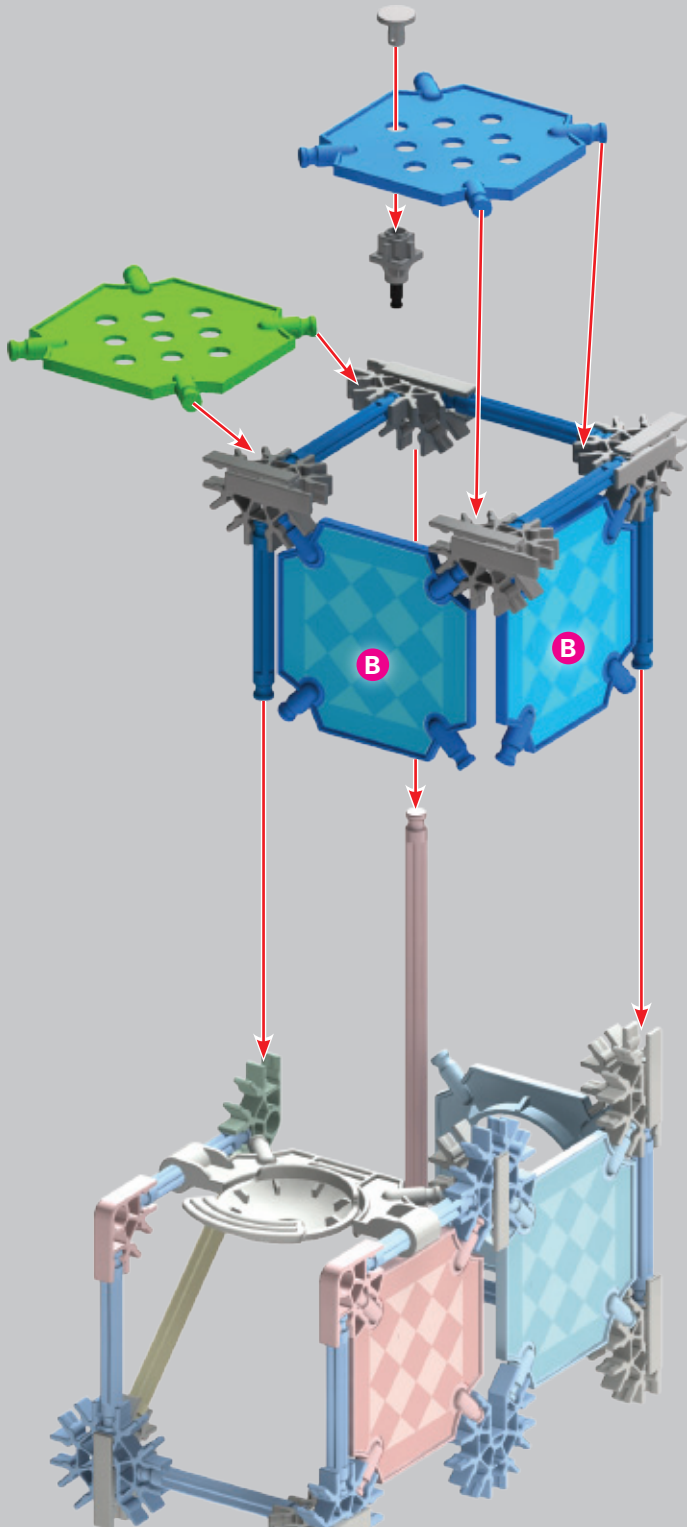

Apply stickers.
Appelez des autocollants.
Aplicar pegatinas.
Bringe die Aufkleber an.
Applicare gli adesivi.
Aplicar adhesivos.
Stickers plakken.

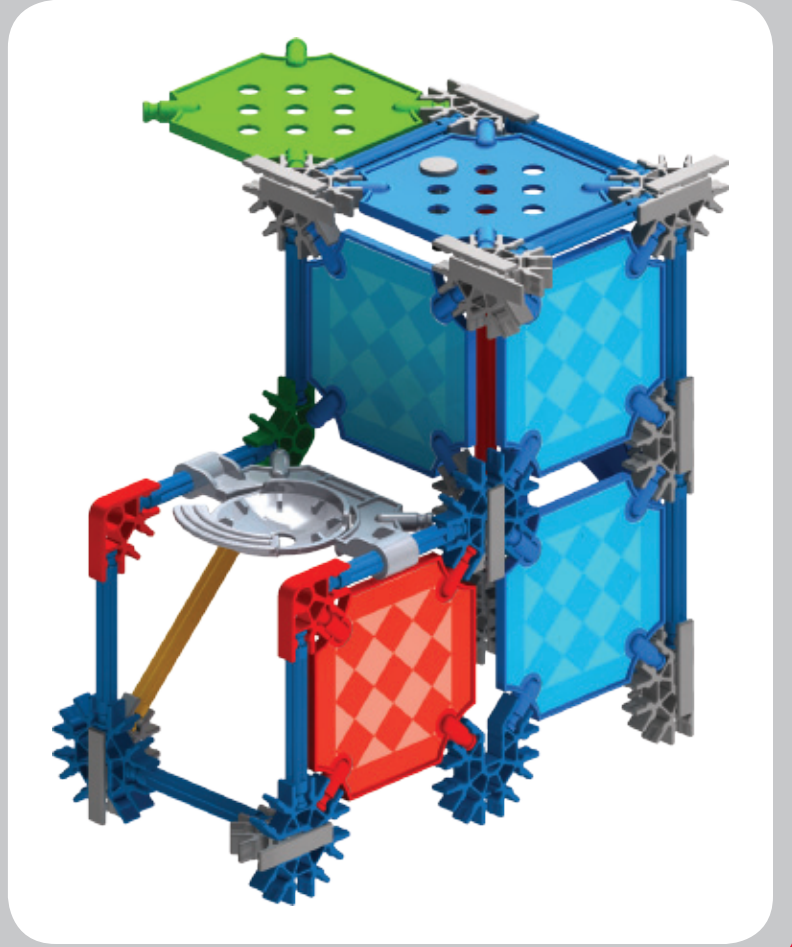

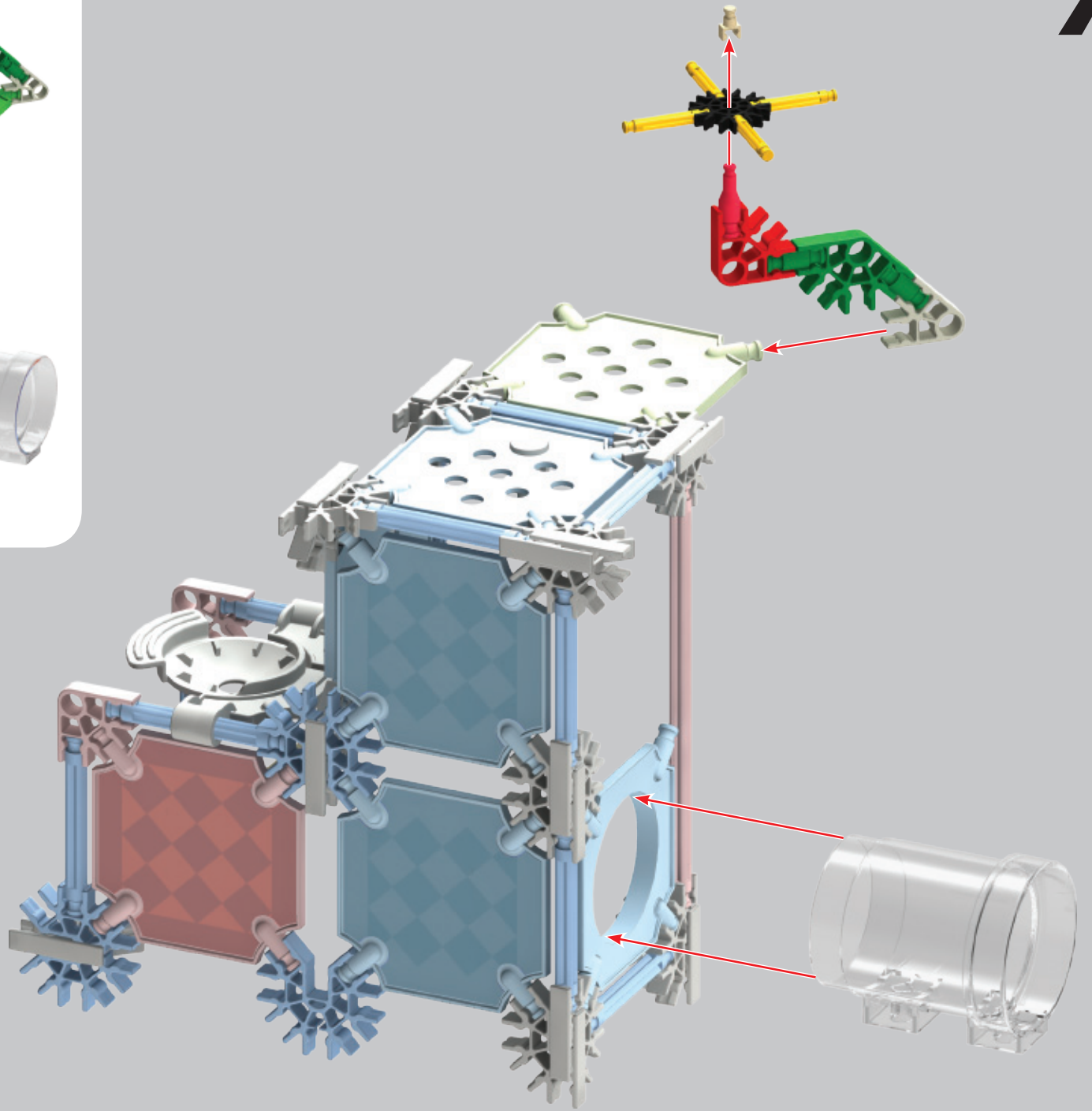

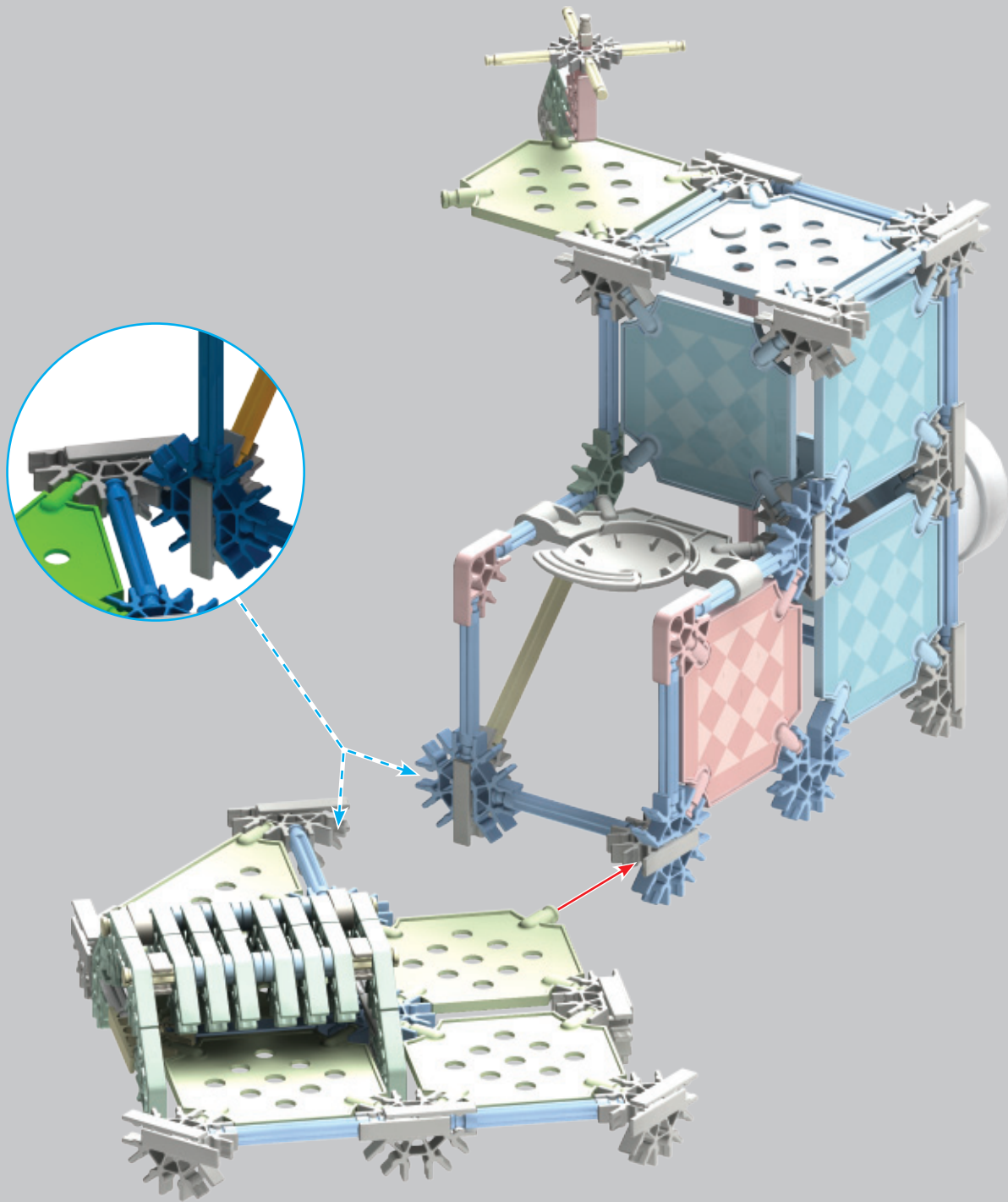

9

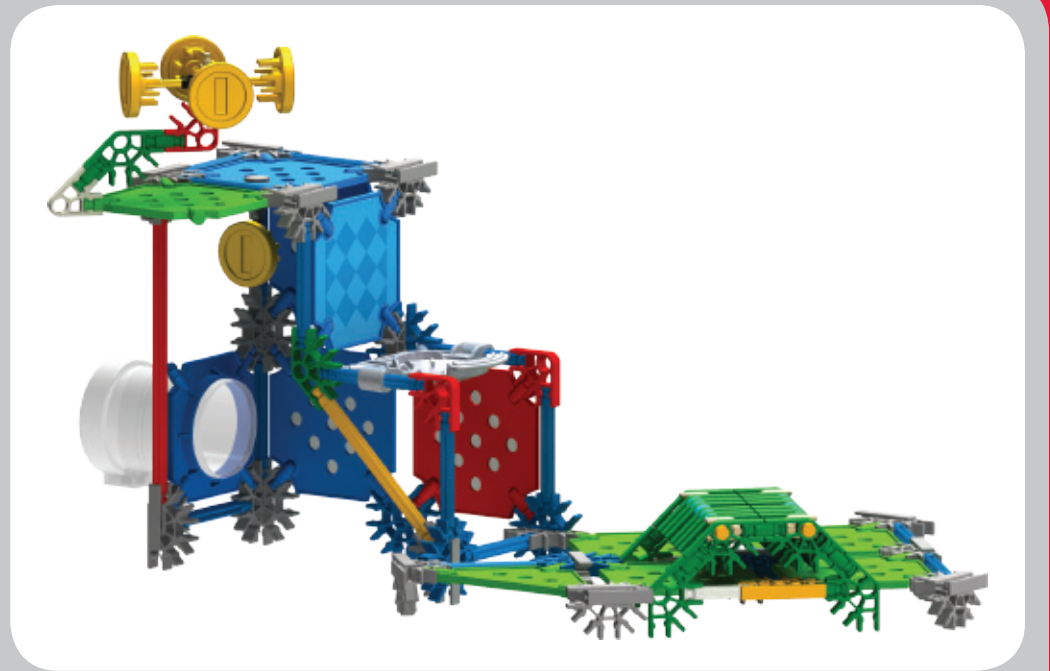
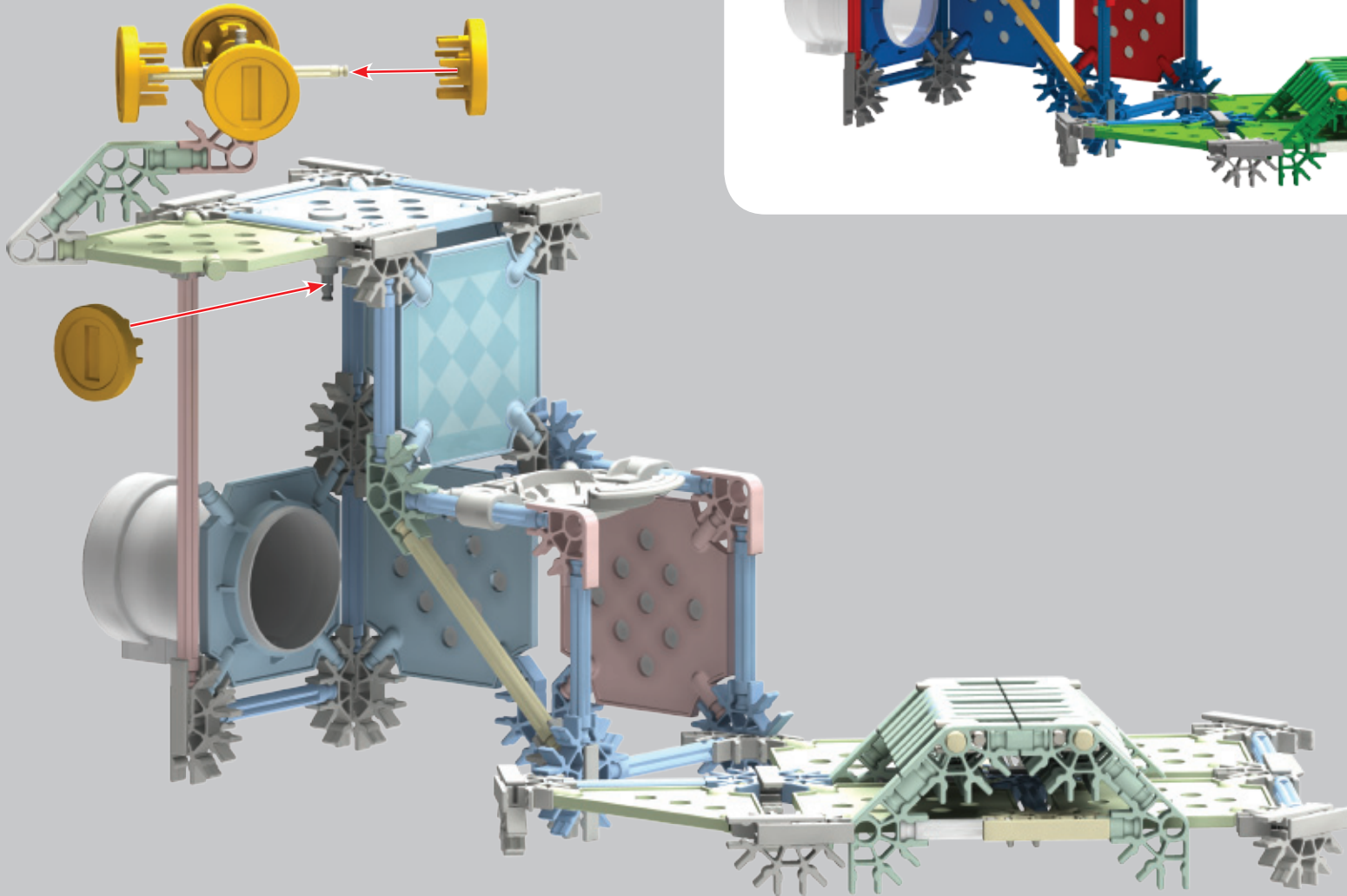

10

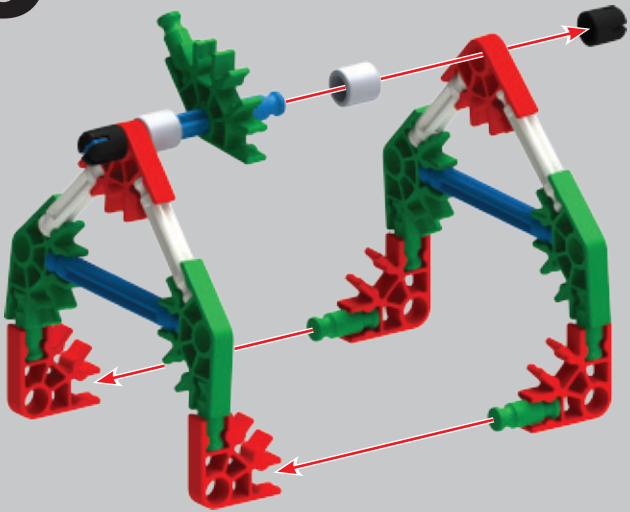

11

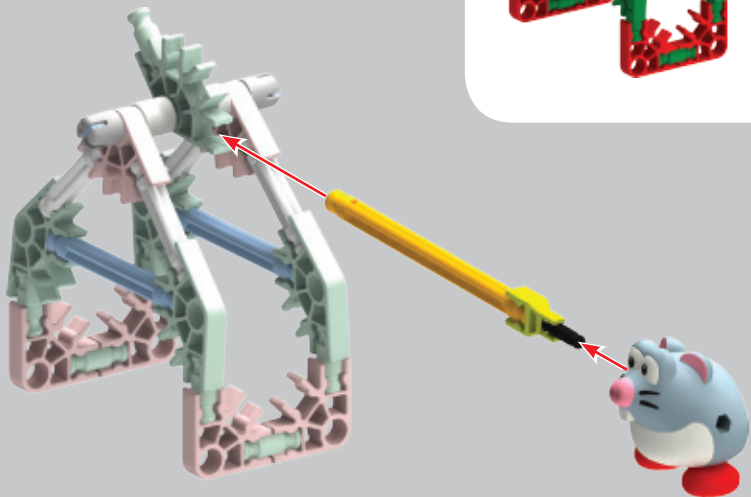

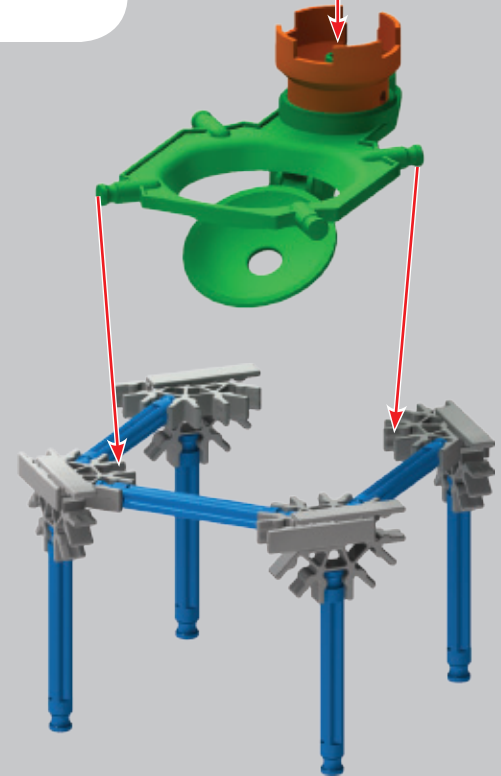
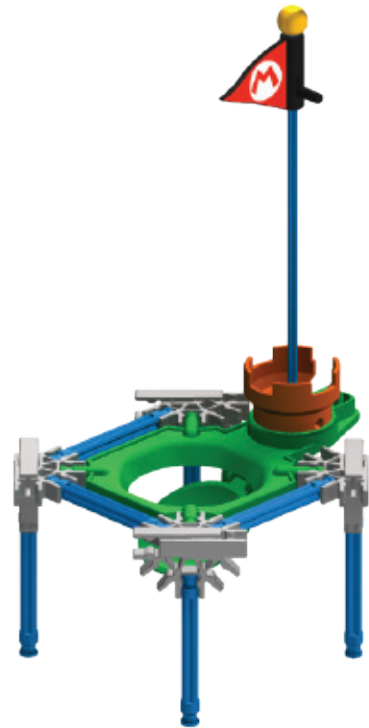
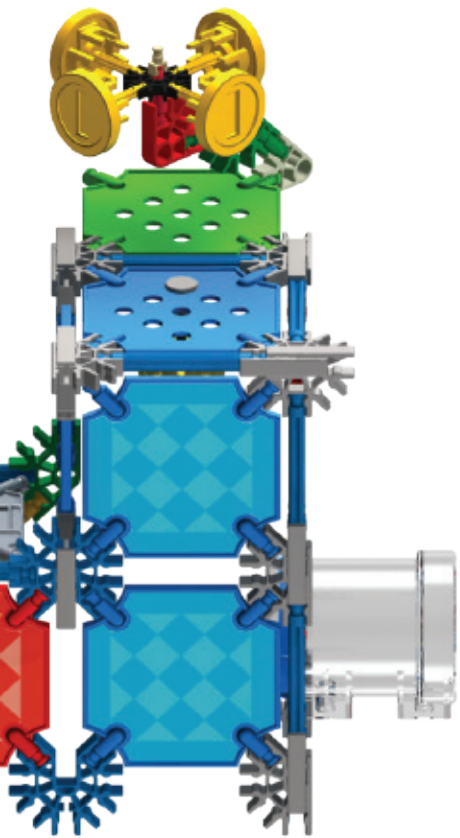

12



Sold separately.
 Vendus séparément. Se venden por separado.
 Separat erhältlich. Venduti separatamente.
 Vendidos separadamente. Afzonderlijk verkocht.

KNEX.COM

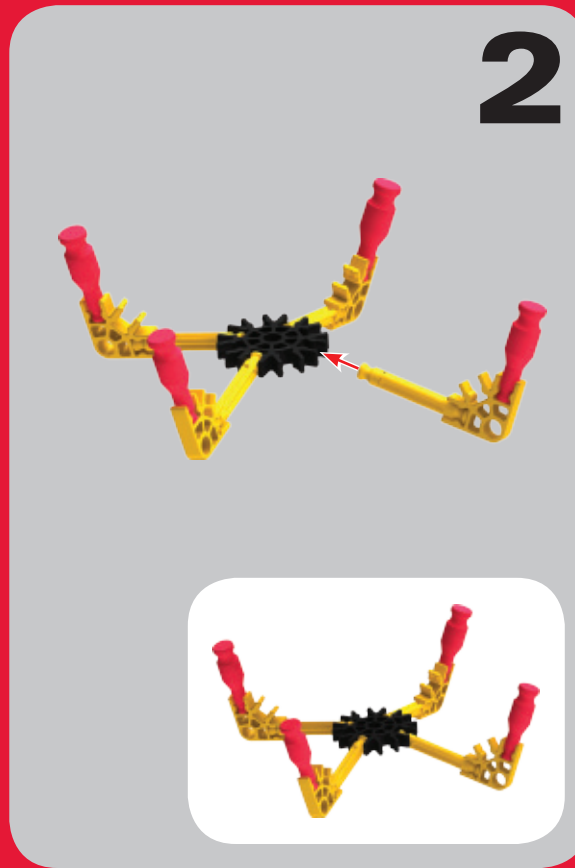

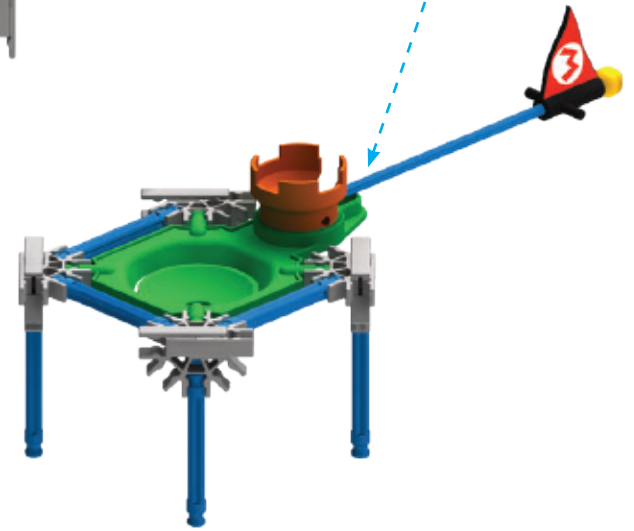
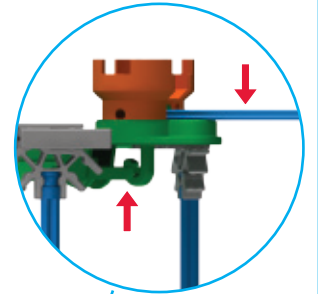
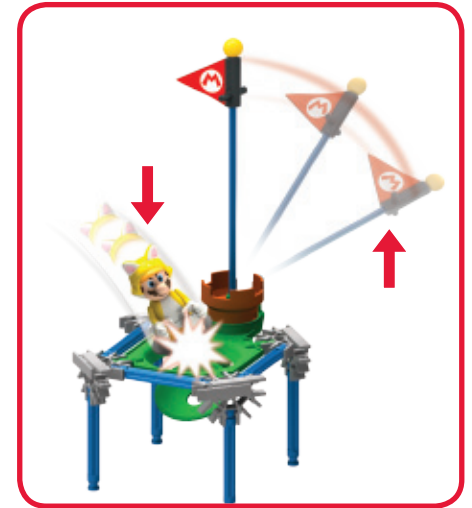

(EN) Keep this important information for future reference. **CAUTION:** Rubber Bands can cause injury from snap-back, breaking, or loss of control. While assembling models shown in instructions, hold rubber band tightly, and do not overstretch. Use Rubber Bands only as shown in these instructions. **DO NOT USE FRAYED OR TORN RUBBER BANDS. CAUTION:** Keep Rubber Bands away from face and eyes.

(FR) Gardez précieusement cette notice pour vous y référer ultérieurement.

ATTENTION : Les élastiques peuvent causer des blessures en claquant, en se cassant ou quand on les manipule imprudemment. Tenez fermement les élastiques lors de l'assemblage du modèle en veillant à ne pas trop les tendre. N'utilisez les élastiques que selon les instructions. **N'UTILISEZ PAS D'ÉLASTIQUES DISTENDUS OU ABIMÉS. ATTENTION :** Tenez les élastiques à l'écart du visage et des yeux.

(ES) Guarde esta información importante para futuras referencias. **PRECAUCIÓN:** Las gomas pueden causar daños si se sueltan con fuerza, se rompen o se pierde su control. Al construir los modelos

que se muestran en las instrucciones, sujetar bien la goma y no estirarla demasiado. Las gomas deben usarse únicamente como se indica en las instrucciones. **NO USAR GOMAS QUE ESTÉN DESGASTADAS NI ASGADAS. PRECAUCIÓN:** Mantenga las gomas elásticas alejadas de la cara y los ojos.

(DE) Informationen für später aufbewahren.

VORSICHT: Gummibänder können Verletzungen hervorrufen, wenn sie reißen, zurückspringen oder wenn sie nicht vorsichtig gehandhabt werden. Halten Sie die Gummibänder während des Zusammenbaus der Modelle fest, ohne sie jedoch zu überdehnen. Verwenden Sie die Gummibänder gemäß den Anweisungen. **VERWENDEN SIE NIEMALS AUSGEFRANSTE ODER ZERRISSENE GUMMIBÄNDER. ACHTUNG:** Halten Sie Gummibänder weg von Gesicht und Augen.

(IT) Conservare queste importanti informazioni per riferimento futuro.

ATTENZIONE: Elastici può causare lesioni da snap-back, rottura, o perdita di controllo. Durante il montaggio dei modelli indicati nelle istruzioni, tenere ben elastico, e non tirare troppo. Utilizzare Elastici solo come indicato in queste istruzioni. **NON USARE**

SFILACCIATI O STRAPPATI ELASTICI. ATTENZIONE: Mantenga gli elastici a partire dal fronte e dagli occhi.

(PT) Manter esta informação importante para referência futura.

CUIDADO: As borrachas poderão causar ferimentos ao serem esticadas, ao quebrarem ou ao perderem controlo. Ao montar os modelos mostrados nas instruções, segure bem a borracha e não a estique demasiado. Utilize as borrachas apenas da forma exemplificada nestas instruções. **NÃO UTILIZE BORRACHAS CORROÍDAS OU QUEBRADAS. CUIDADO:** Mantenha as faixas de borracha longe da cara e dos olhos.

(NL) Bewaar deze belangrijke informatie, zodat u deze in de toekomst opnieuw kunt raadplegen.

LET OP: Elastiekjes kunnen letsel veroorzaken als ze wegschieten, kapotgaan of als er achteloos mee wordt omgegaan. Houd elastiekjes goed vast als je modellen bouwt volgens de instructies. Rek ze niet te ver uit. Gebruik elastiekjes uitsluitend zoals in de instructies beschreven staat. **GEBRUIK GEEN GERAFFELDE OF GESCHEURDE ELASTIEKJES. LET OP:** houd elastiekjes uit de buurt van het gezicht en de ogen.



WARNING: CHOKING HAZARD – Toy contains a small ball and small parts. Not for children under 3 years.

ATTENTION : RISQUE D'ÉTOUFFEMENT – Ce jouet contient une bille en plastique et des pièces de petite taille. Ne convient pas aux enfants de moins de 3 ans.

ADVERTENCIA: PELIGRO DE ASFIXIA – Juguete contiene una pequeña bola y piezas pequeñas. No recomendado para niños menores de 3 años.

ACHTUNG: ERSTICKUNGSGEFAHR – Spielzeug enthält einen kleinen Ball und Kleinteile. Nicht für Kinder unter 3 Jahren.

AVVISO: PERICOLO DI SOFFOCARE – Giocattolo a una piccola pallina e pezzi piccoli. Non adatto per bambini sotto 3 anni.

AVISO: PERIGO DE SUFOCAÇÃO – Toy contém uma pequena bola e peças pequenas. Não indicado para crianças menores de 3 anos.

WAARSCHUWING: INSLIKKINGSGEVAAR – Dit speelgoed bevat een balletje en kleine onderdelen. Niet geschikt voor kinderen jonger dan 3 jaar.

CAUTION: Do not launch in the direction of people, animals, or walls; you could cause injury or damage.

ATTENTION : Ne pas lancer en direction des personnes, des animaux ni des murs. Risque de blessure ou d'endommagement.

PRECAUCIÓN: No lance en dirección de gente, de animales, o de paredes; usted podría estropear lesión o.

VORSICHT: Nicht auf Menschen, Tiere oder Wände werfen; könnte Verletzungen oder Schäden verursachen.

AVVERTENZA: Non lanci in direzione della gente, degli animali, o delle pareti; potreste causare la lesione o il danno.

CUIDADO: Não lançe no sentido dos povos, dos animais, ou das paredes; você poderia causar ferimento ou dano.

LET OP: Richt nooit op mensen, dieren of muren. Hierdoor kun je letsel of schade veroorzaken.

©2014 K'NEX Limited Partnership Group, P.O. Box 700, Hatfield, PA 19440-0700; 1-800-KID-KNEX (USA/Canada/États-Unis/EE.UU.); K'NEX UK Ltd., P.O. Box 3083, Reading RG1 9YQ, England; knex.com; email@knex.com.

K'NEX, Building Worlds Kids Love and America's Building Toy are registered trademarks of K'NEX Limited Partnership Group. Product and colors may vary. For customers outside the USA and Canada please contact your local distributor at www.knex.com/distributors.

K'NEX, Building Worlds Kids Love et America's Building Toy sont des marques déposées de K'NEX Limited Partnership Group. Produits et couleurs peuvent varier. Pour les clients en dehors du Canada et des États-Unis, veuillez contacter votre distributeur local que vous pouvez trouver sur www.knex.com/distributors.

K'NEX, Building Worlds Kids Love y America's Building Toy son marcas registradas de K'NEX Limited Partnership Group. El producto y los colores pueden variar. El cliente que no vive en EE.UU. y Canadá se pone en contacto con el distribuidor local. Encuentre la información para el distribuidor local en www.knex.com/distributors.

TM & © 2014 Nintendo.

KNEX.COM

 facebook.com/buildknex

America's Building Toy®
Jeu de Construction Américain
Juguete de Construcción de América
Amerikas Bauspielzeug
Gioco di Costruzione dell'America
Brinquedo de construção da América
Het bouwspelgoed van Amerika

‡ Clear Warp Pipe!
Tuyau translucide !
‡Tubo Warp Claro!
Durchsichtige Warp-Röhre!
Trasparente condotto
spazio-temporale!
Claro tubo de urdidura!
Transparante warpbuis!

† Limited Edition!
Édition Limitée !
Edición Limitada!
Limited Edition!
Edizione Limitata!
Edição Limitada!
Bepèrkte Uitgave!

138635-V1-03/14

