



MARIO KART™

Wii

6+

MARIO™ CIRCUIT ULTIMATE BUILDING SET

ULTIME JEU DE
CONSTRUCTION

2 Motorized Karts
Karts Motorisé
Karts Motorizado



38501/71938

K'NEX®

1

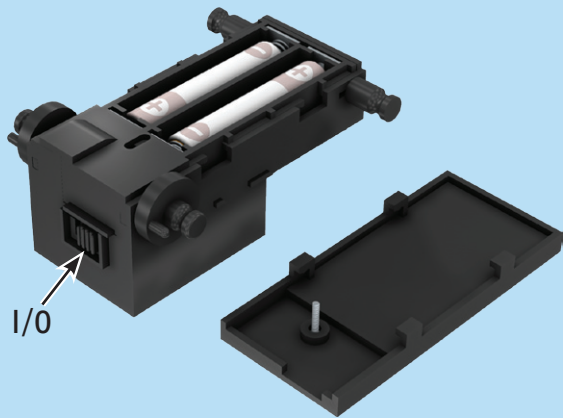

MARIOKART™

Wii

WARNING: CHOKING HAZARD – SMALL PARTS.
Not for children under 3 years.

ATTENTION ! RISQUE D'ÉTOUFFEMENT – PIÈCES DE PETITE TAILLE. Ne convient pas aux enfants de moins de 3 ans.

ADVERTENCIA: PELIGRO DE ASFIXIA – PIEZAS PEQUEÑAS. No para niños menores de 3 años.

WARNHINWEIS: ERSTICKUNGSGEFAHR – KLEINTEILE. Nicht geeignet für Kinder unter 3 Jahren.

AVVERTENZA: PERICOLO DI SOFFOCAMENTO – CONTIENE PICCOLE PARTI. Non adatto per bambini al di sotto di 3 anni.

AVISO: PERIGO DE SUFOCAÇÃO – PEÇAS PEQUENAS. Não se destina a crianças com menos de 3 anos de idade.

WAARSCHUWING: VERSTIKKINGSGEVAAR – KLEINE ONDERDELEN. Niet geschikt voor kinderen onder 3.



2

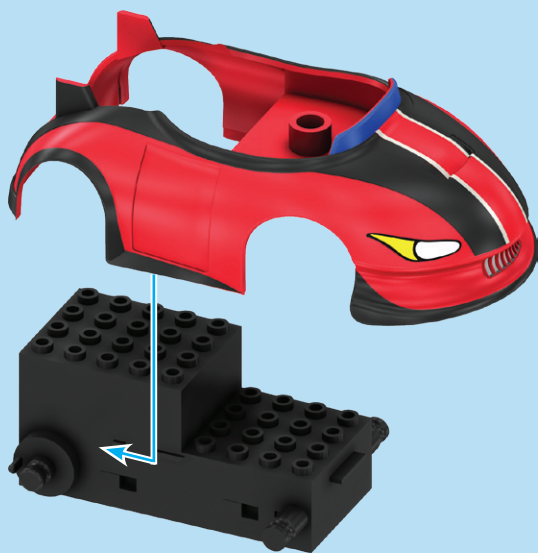

- Apply stickers
- Apposez des autocollants
- Aplicar pegatinas
- Anbringen von Aufklebern
- Applicare gli adesivi
- Aplicar adesivos
- Aanbrengen stickers

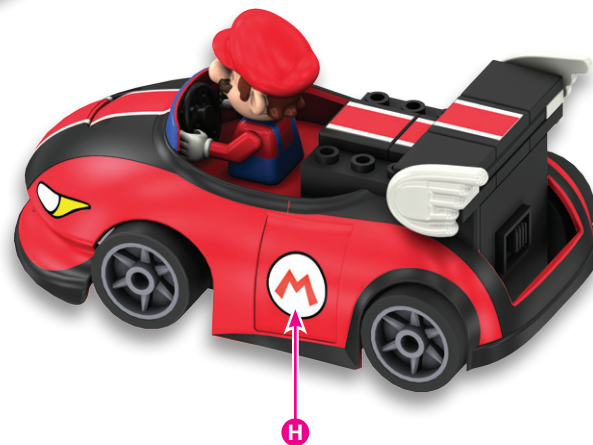

3

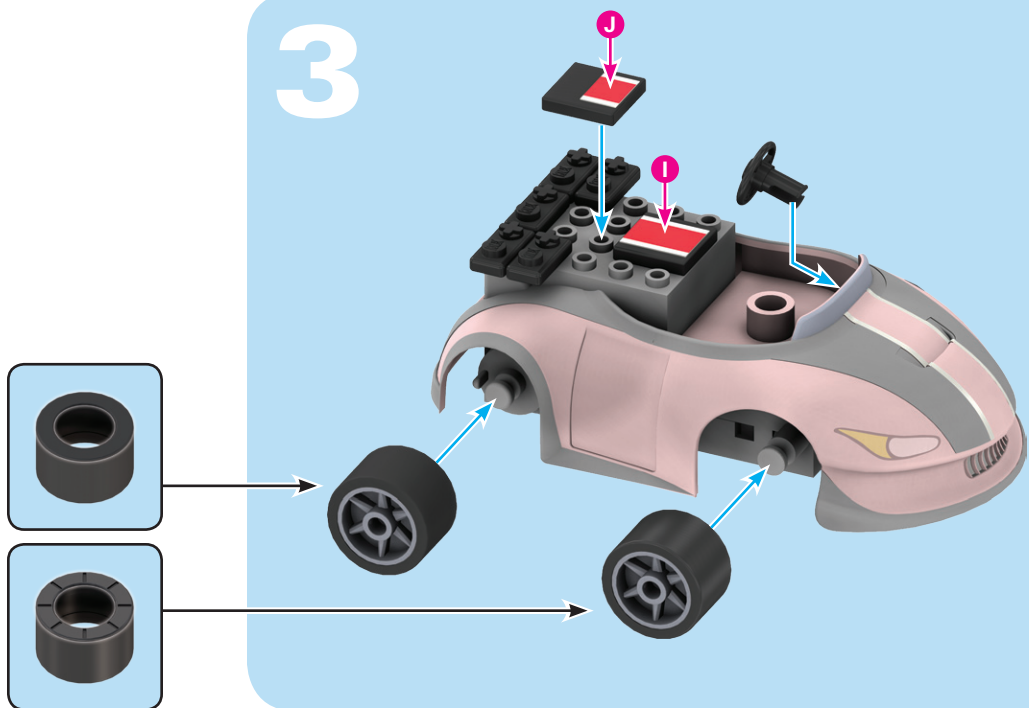

4

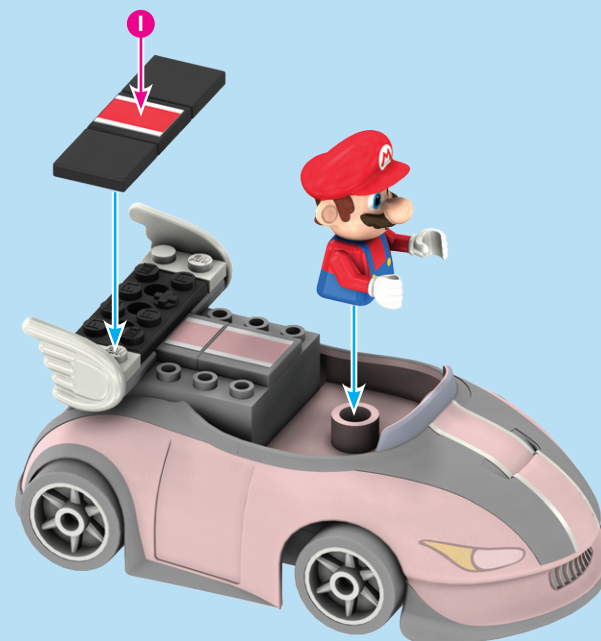

1

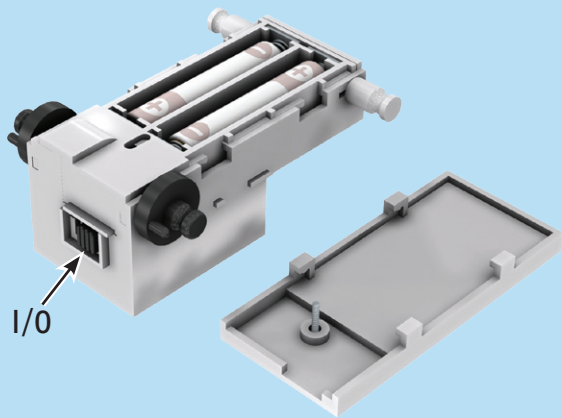

2

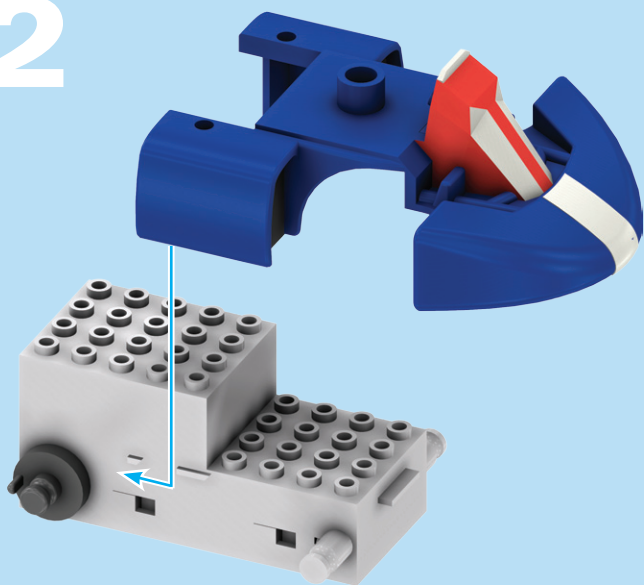

MARIOKART™

Wii

! WARNING: CHOKING HAZARD – SMALL PARTS.
Not for children under 3 years.
ATTENTION ! RISQUE D'ÉTOUFFEMENT – PIÈCES DE PETITE TAILLE. Ne convient pas aux enfants de moins de 3 ans.

ADVERTENCIA: PELIGRO DE ASFIXIA – PIEZAS PEQUEÑAS. No para niños menores de 3 años.

WARNHINWEIS: ERSTICKUNGSGEFAHR – KLEINTEILE. Nicht geeignet für Kinder unter 3 Jahren.

AVVERTENZA: PERICOLO DI SOFFOCAMENTO – CONTIENE PICCOLE PARTI. Non adatto per bambini al di sotto di 3 anni.

AVISO: PERIGO DE SUFOCAÇÃO – PEÇAS PEQUENAS. Não se destina a crianças com menos de 3 anos de idade.

WAARSCHUWING: VERSTIKKINGSGEVAAR – KLEINE ONDERDELEN. Niet geschikt voor kinderen onder 3.

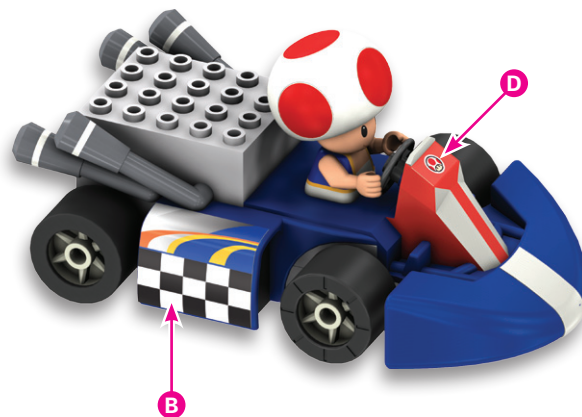

- Apply stickers
- Apposez des autocollants
- Aplicar pegatinas
- Anbringen von Aufklebern
- Applicare gli adesivi
- Aplicar adesivos
- Aanbrengen stickers



3

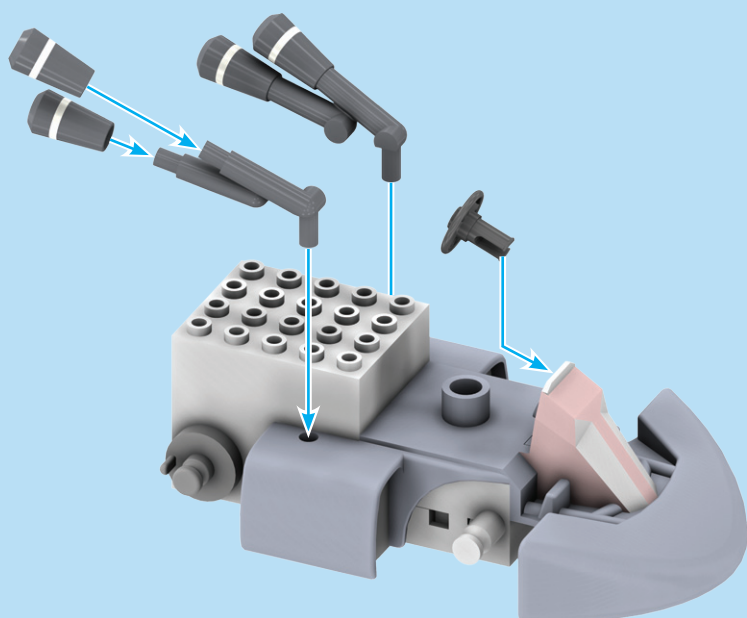

4

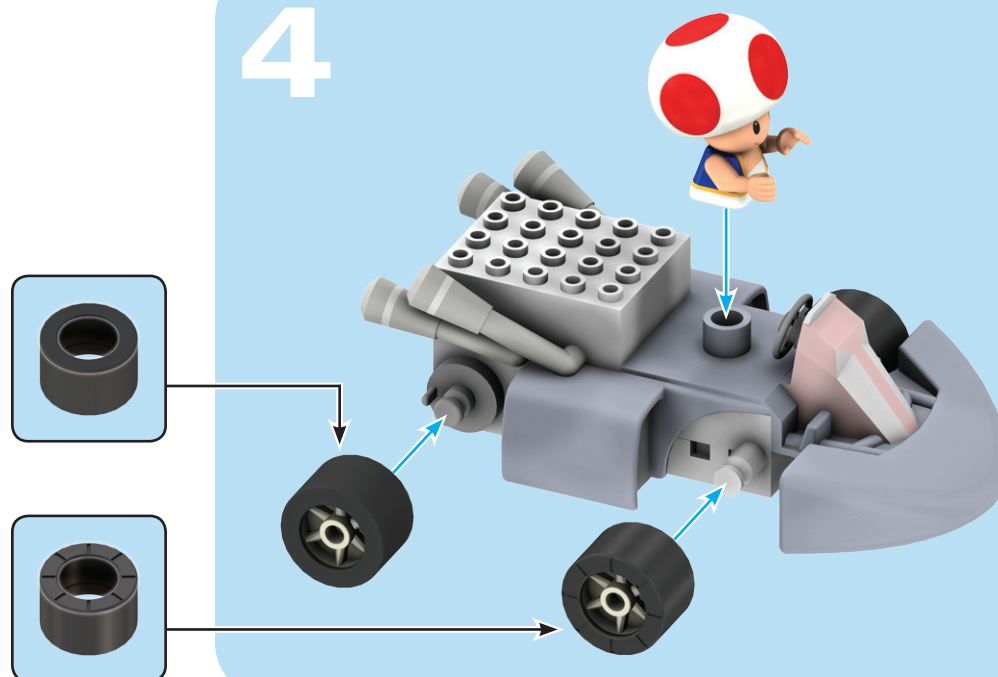

MARIO™ CIRCUIT

ULTIMATE BUILDING SET

ULTIME JEU DE CONSTRUCTION

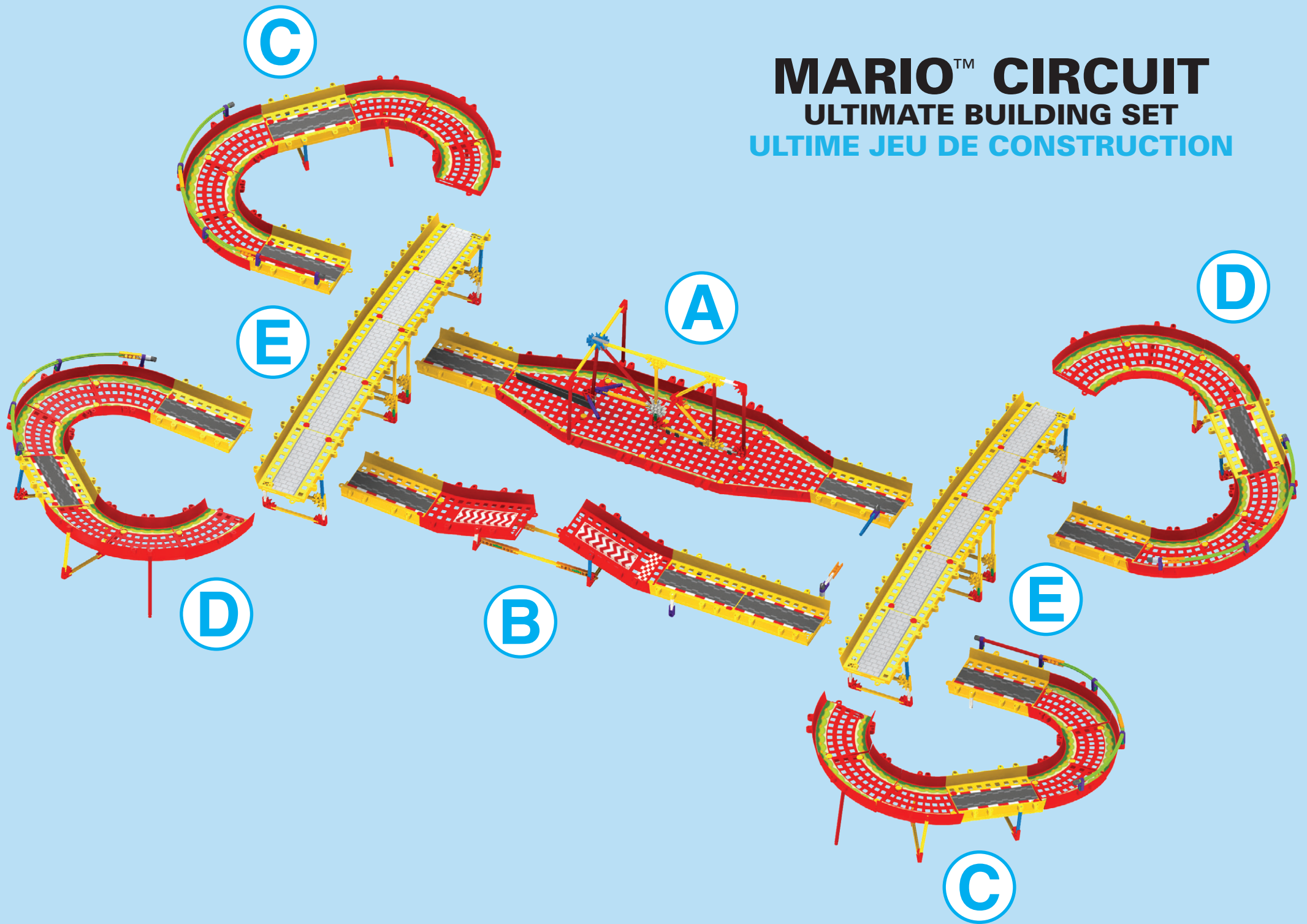

1

A

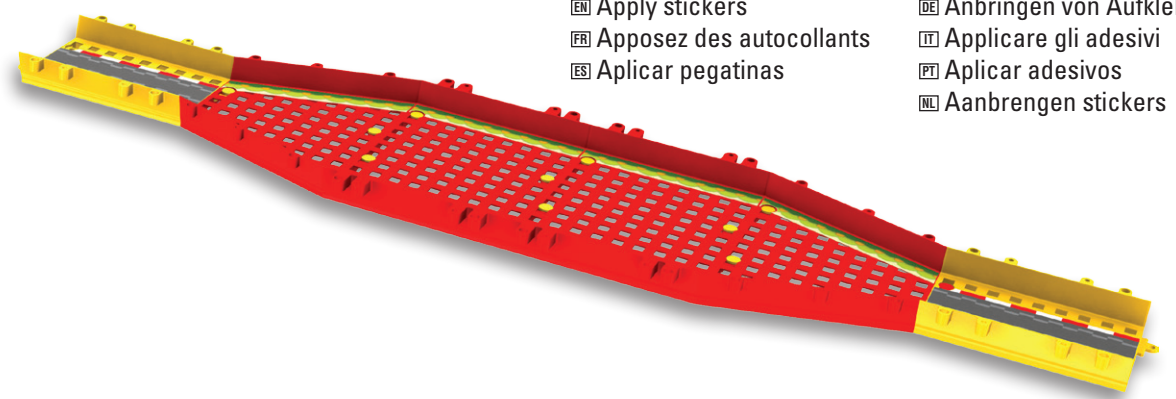
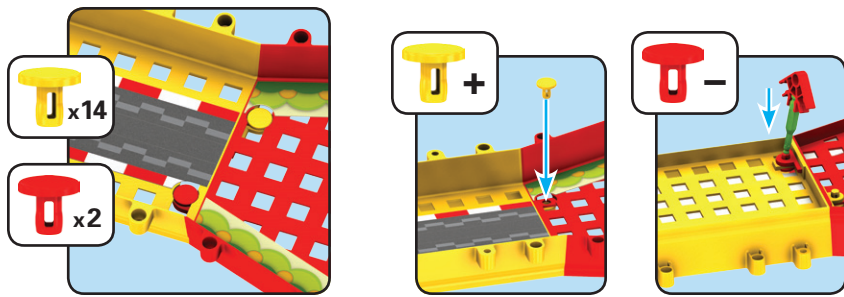
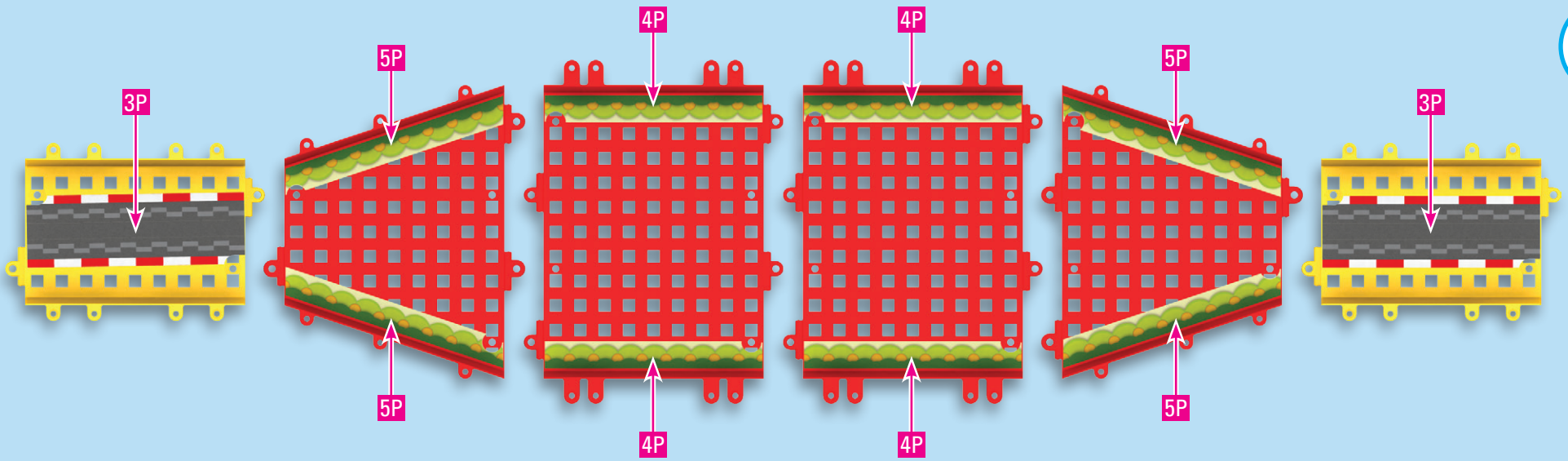

- Apply stickers
- Anbringen von Aufklebern
- Appezer des autocollants
- Applicare gli adesivi
- Aplicar pegatinas
- Aplicar adesivos
- Aanbrengen stickers

2

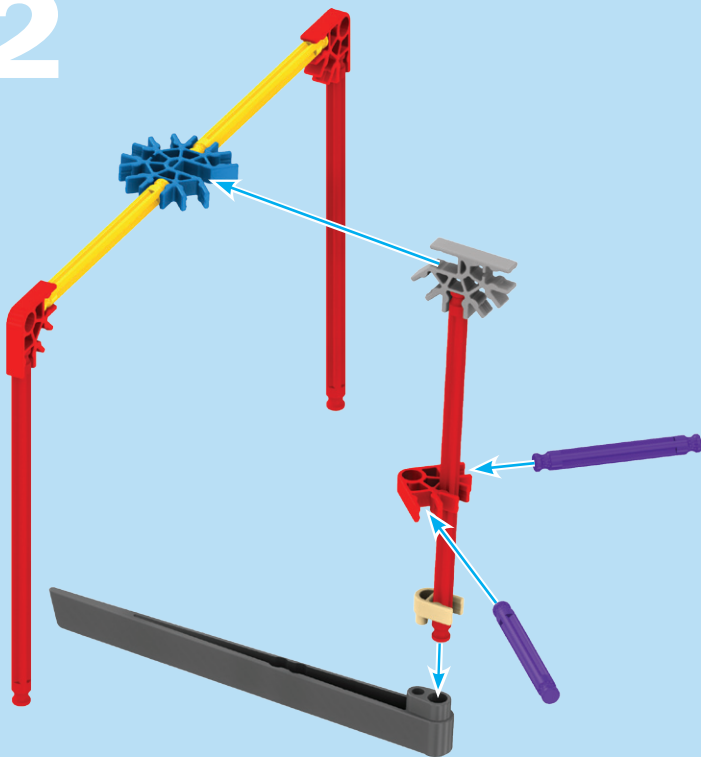

3



4

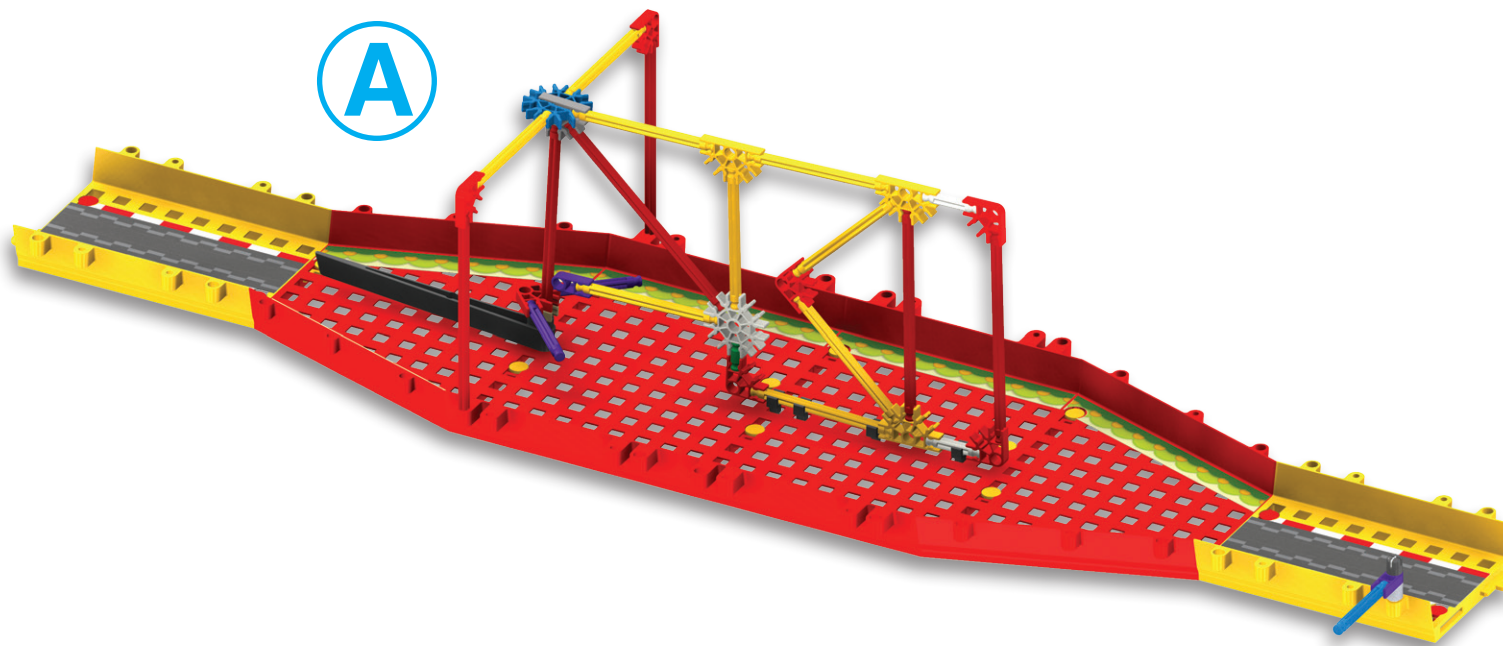
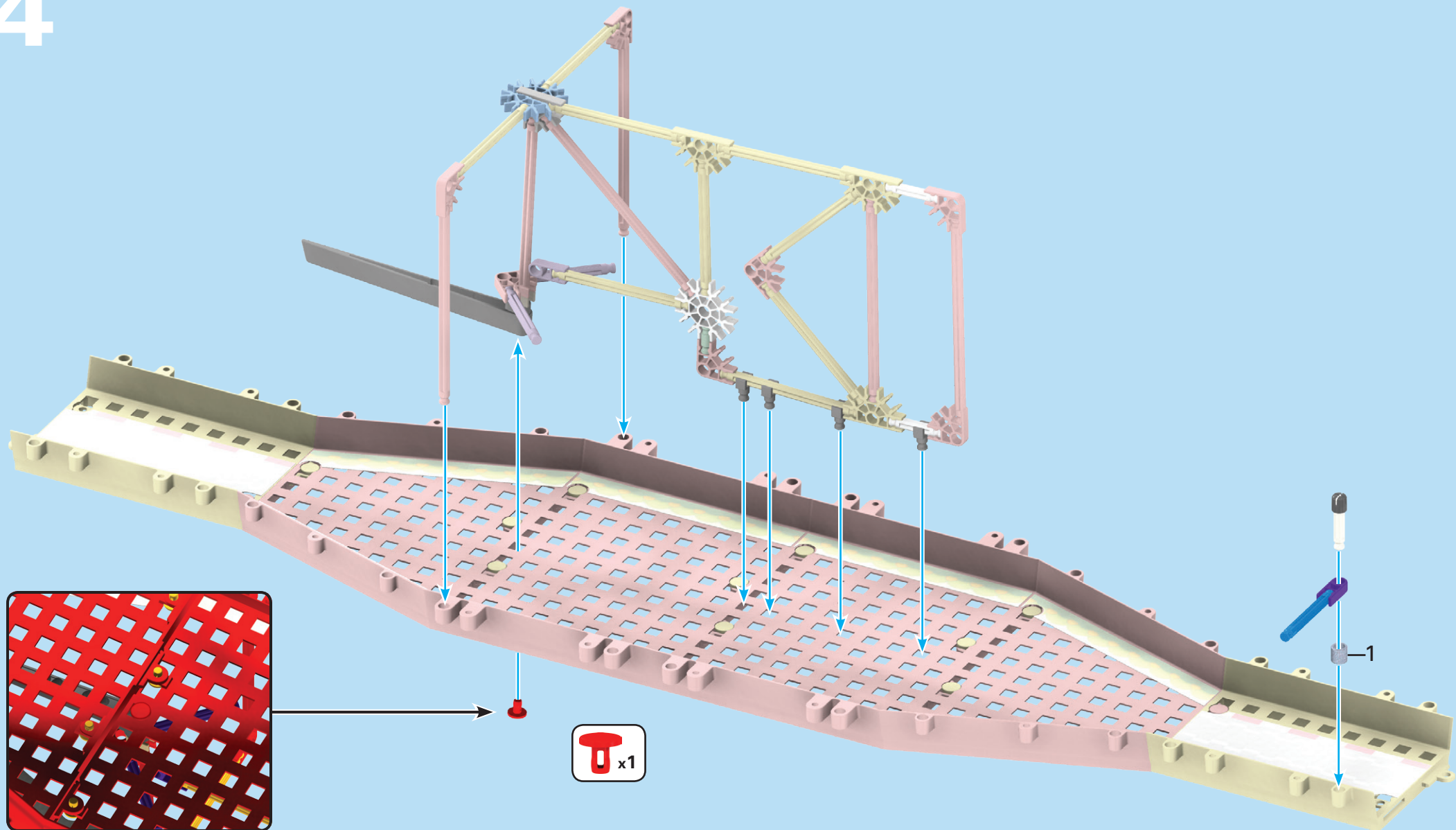

1

B

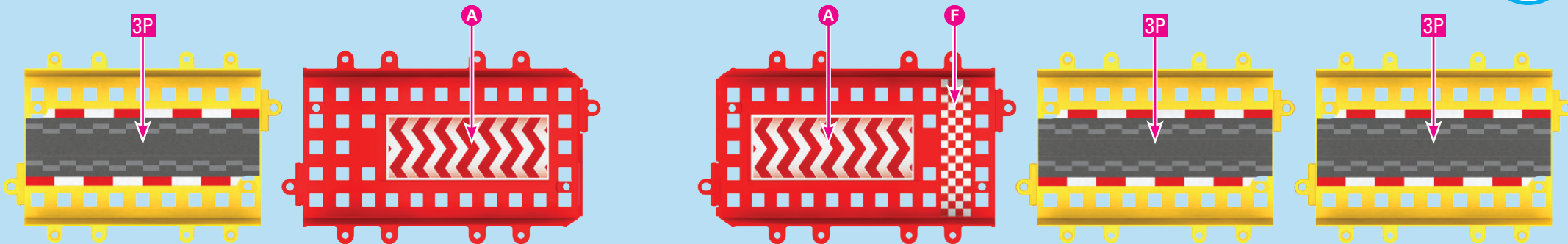

Apply stickers
Appelez des autocollants

Aplicar pegatinas
Anbringen von Aufklebern

Applicare gli adesivi
Aplicar adesivos

Aanbrengen
stickers

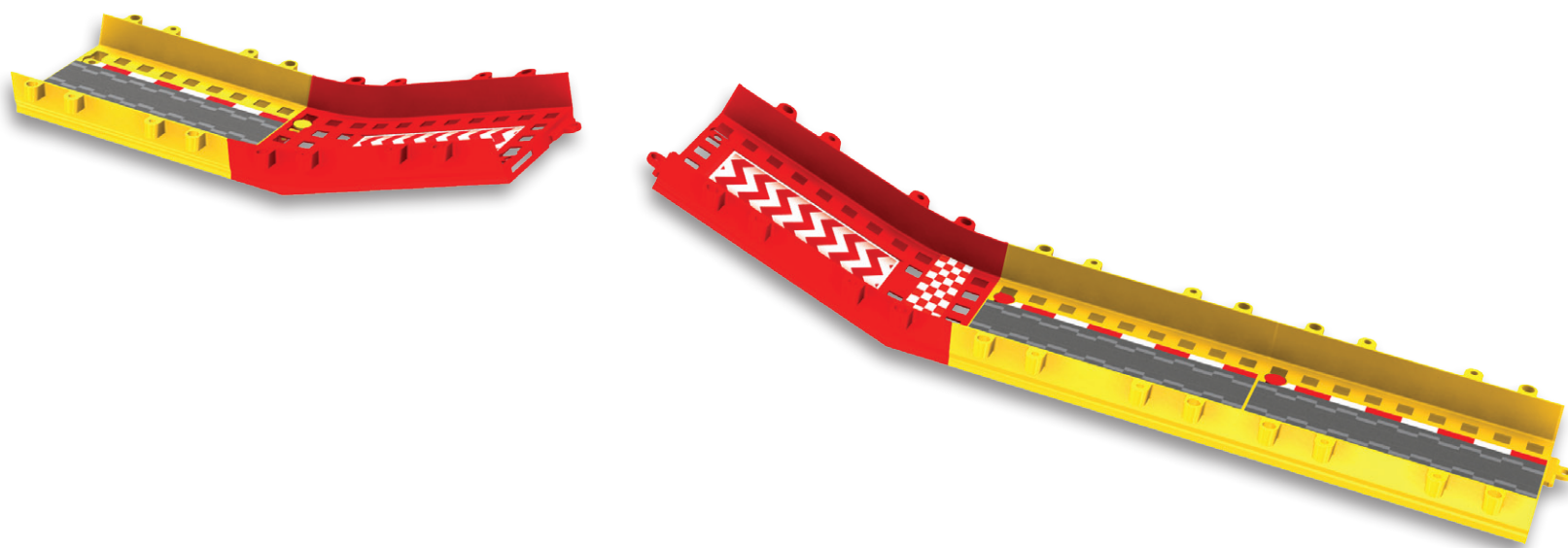
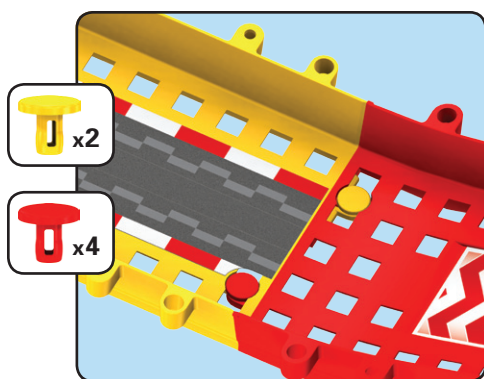

2

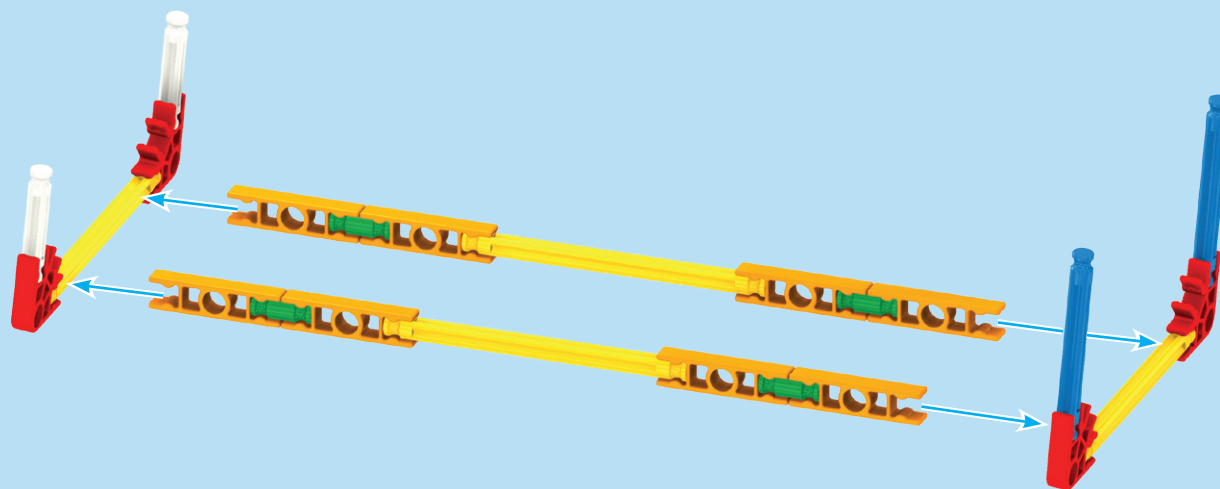

3



x2

4

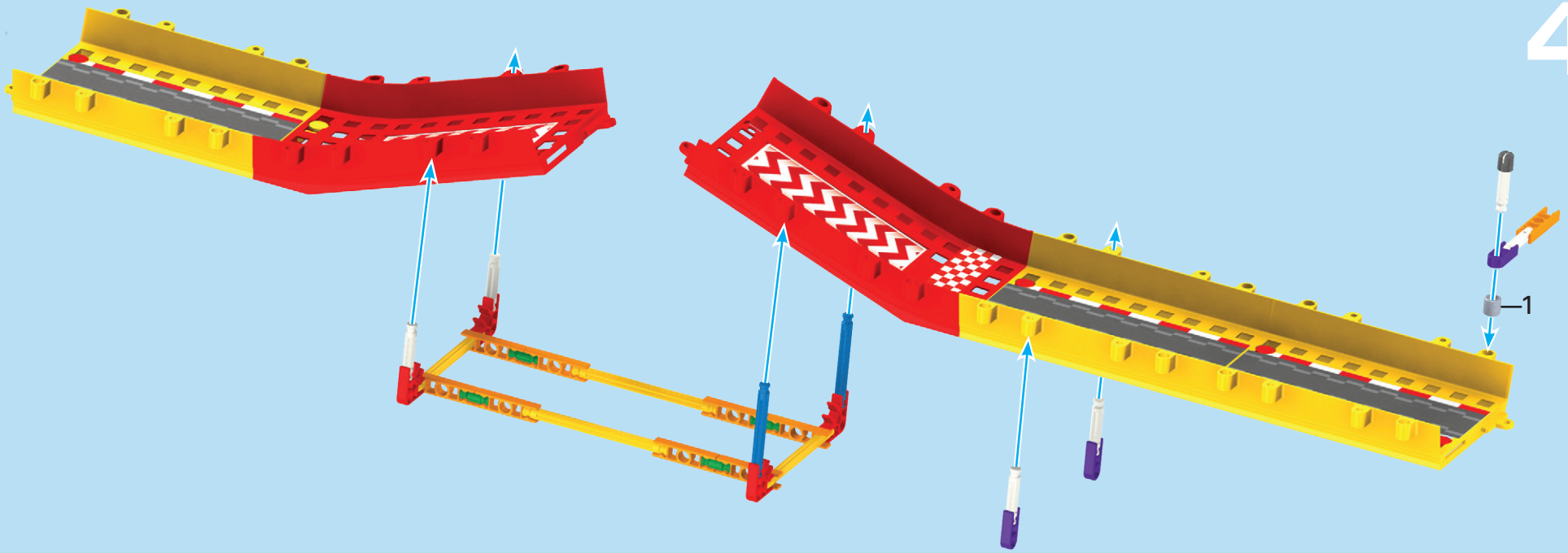

B



5

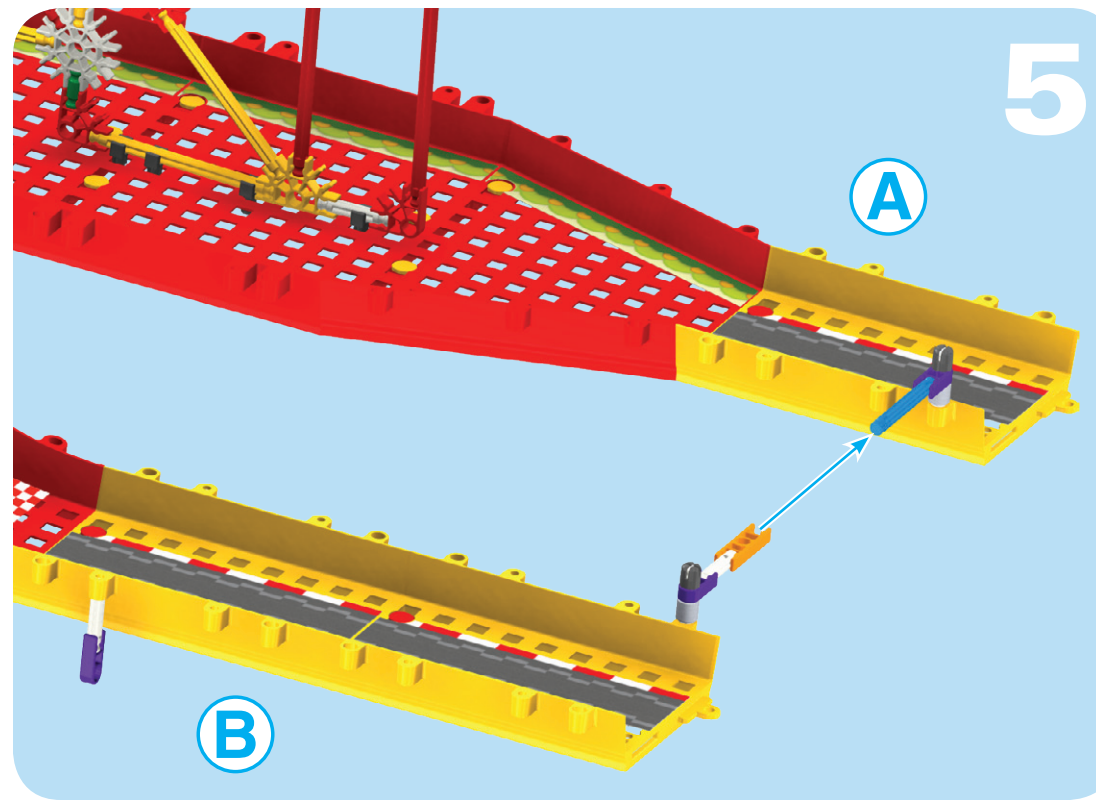

A B

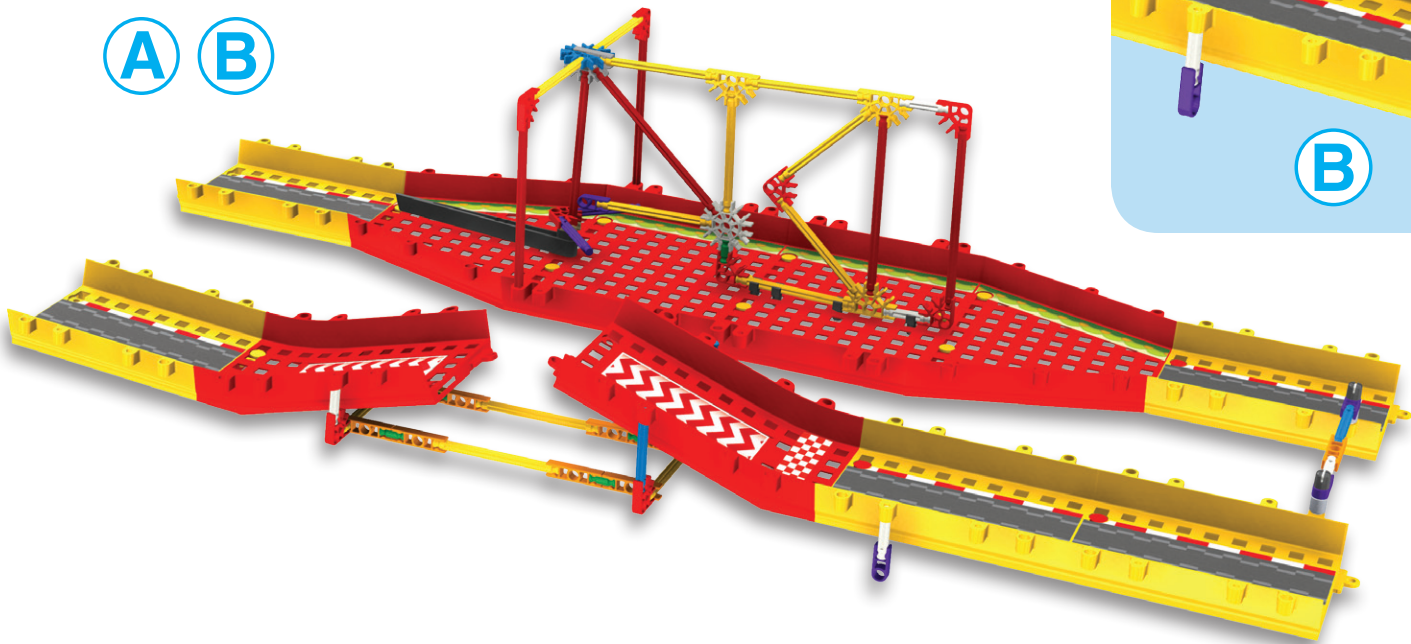

1

C

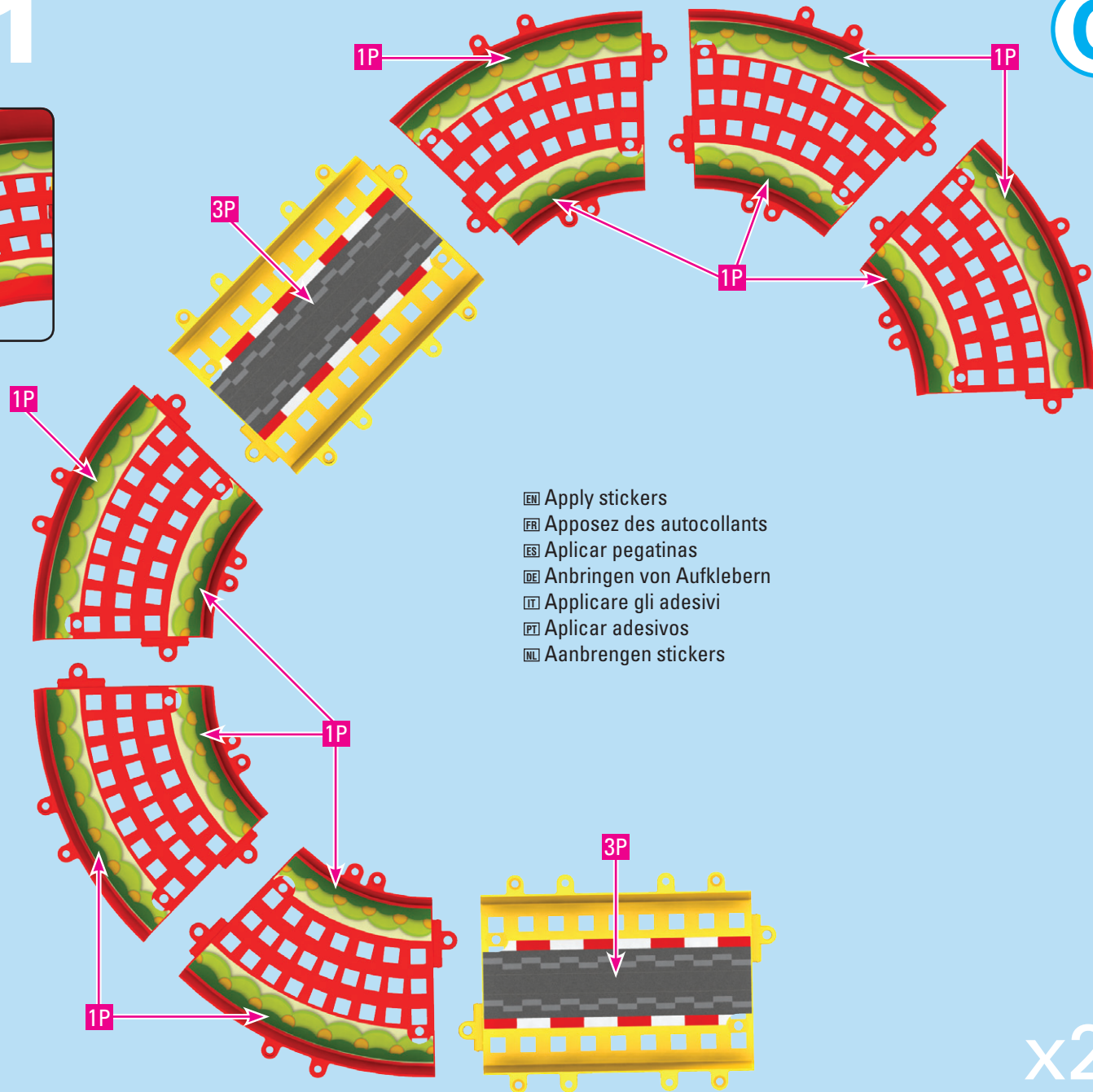
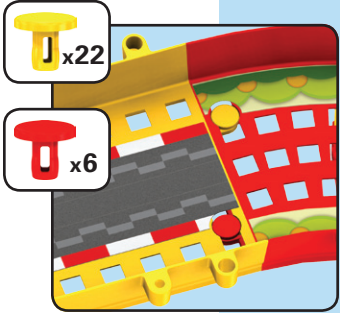

- Apply stickers
- Appelez des autocollants
- Aplicar pegatinas
- Anbringen von Aufklebern
- Applicare gli adesivi
- Aplicar adhesivos
- Aanbrengen stickers

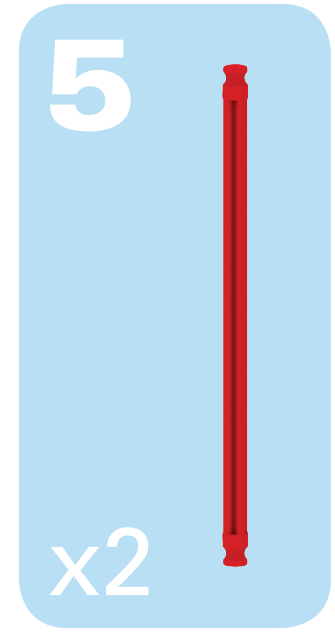
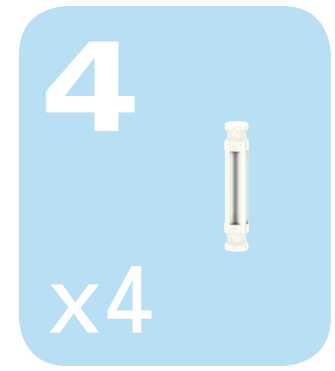
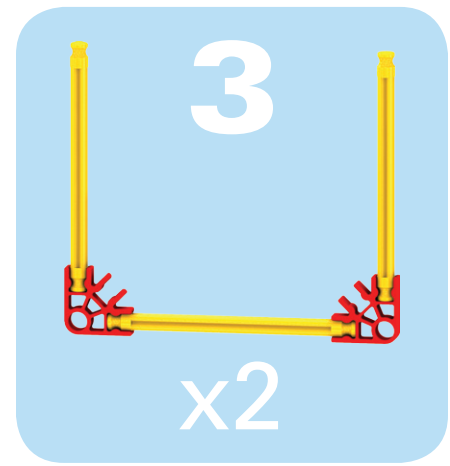
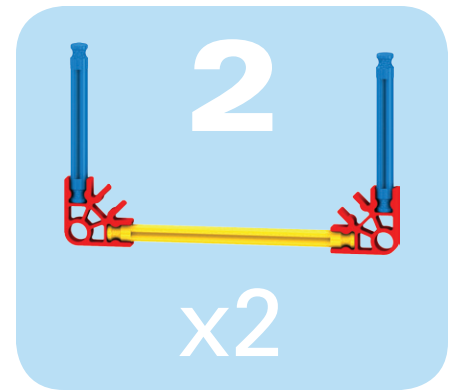
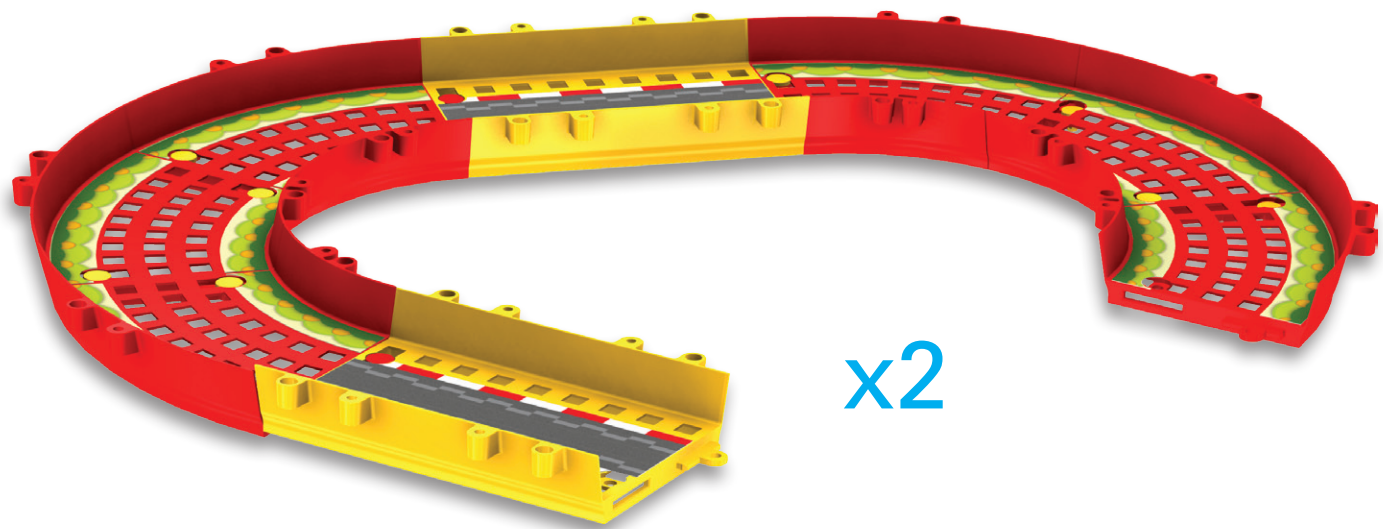

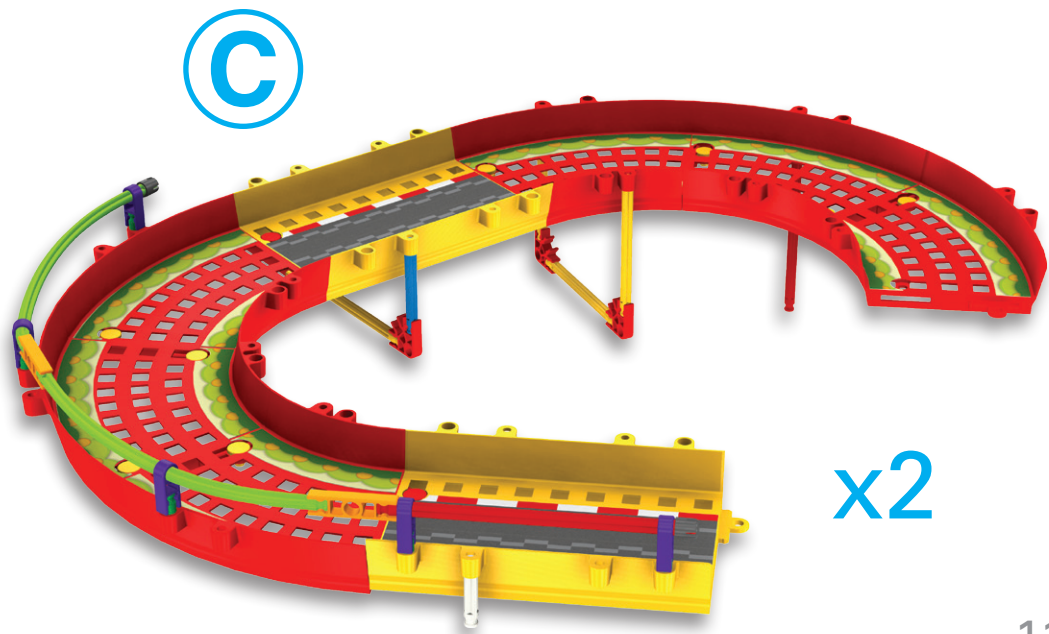
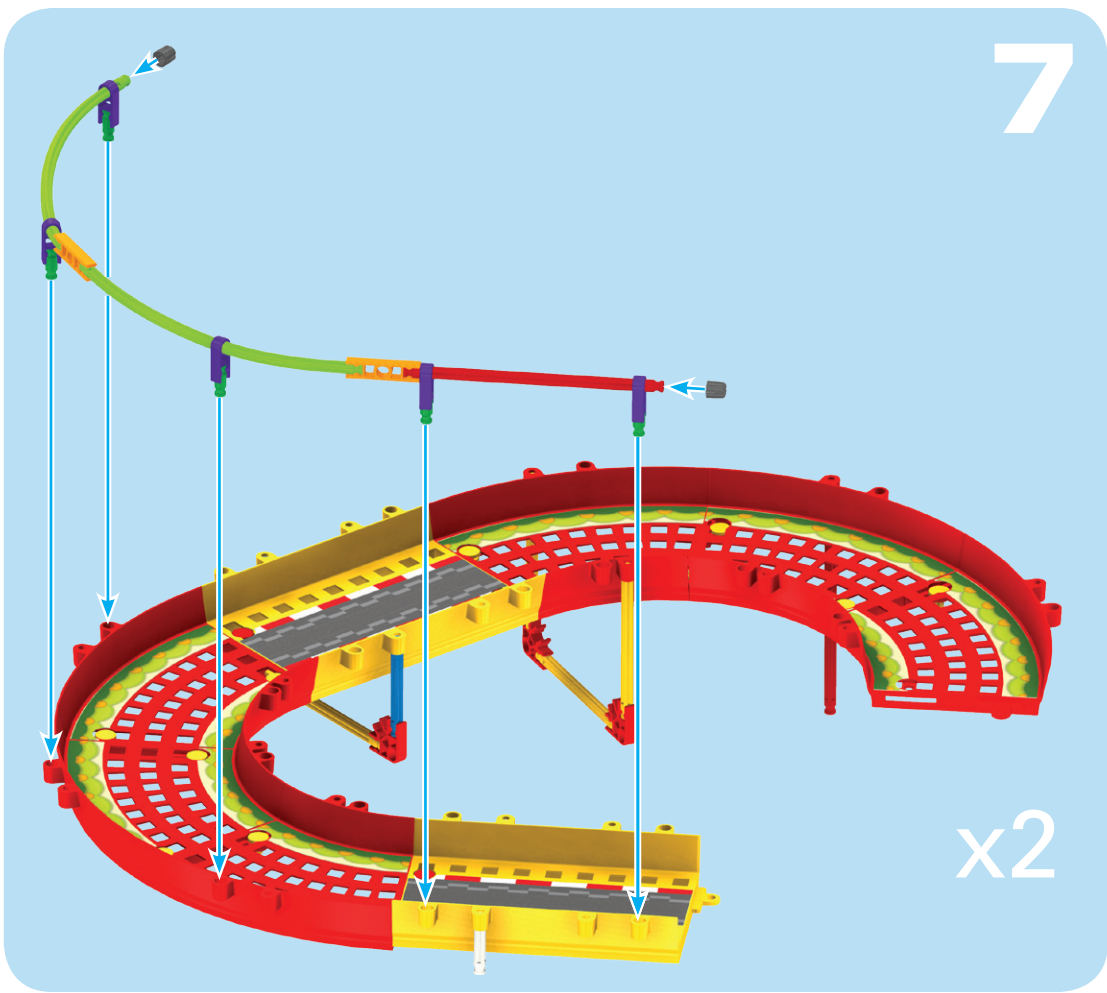
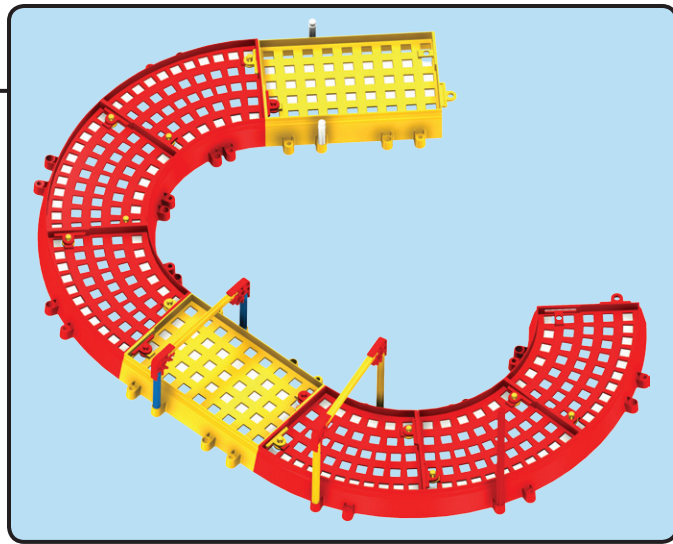
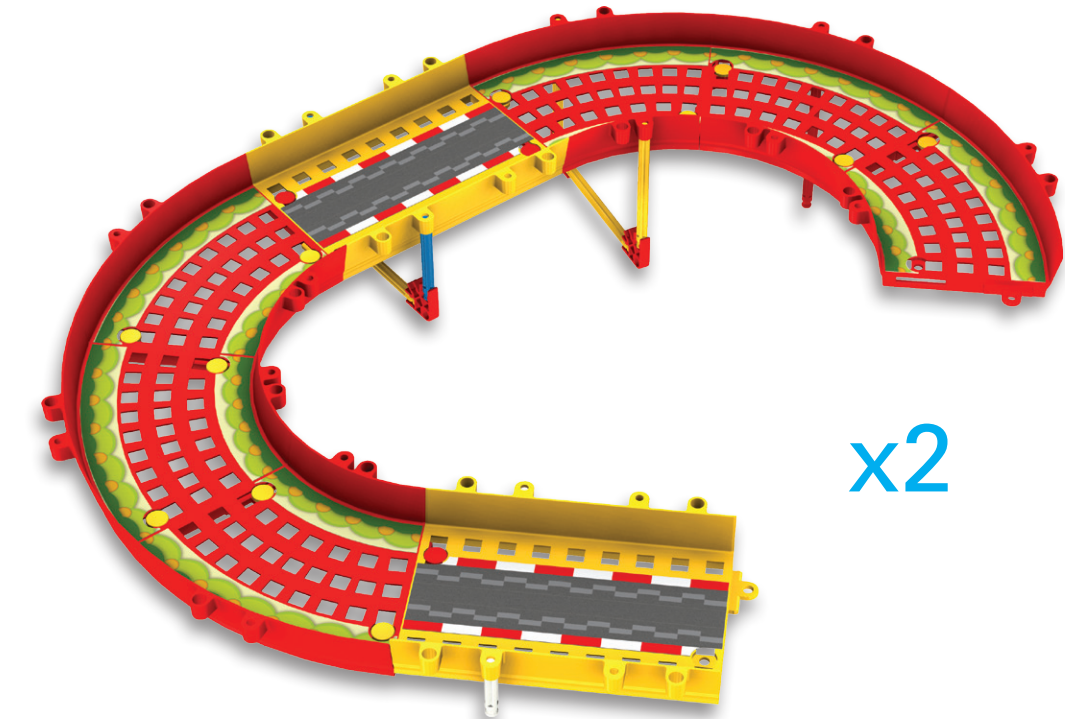
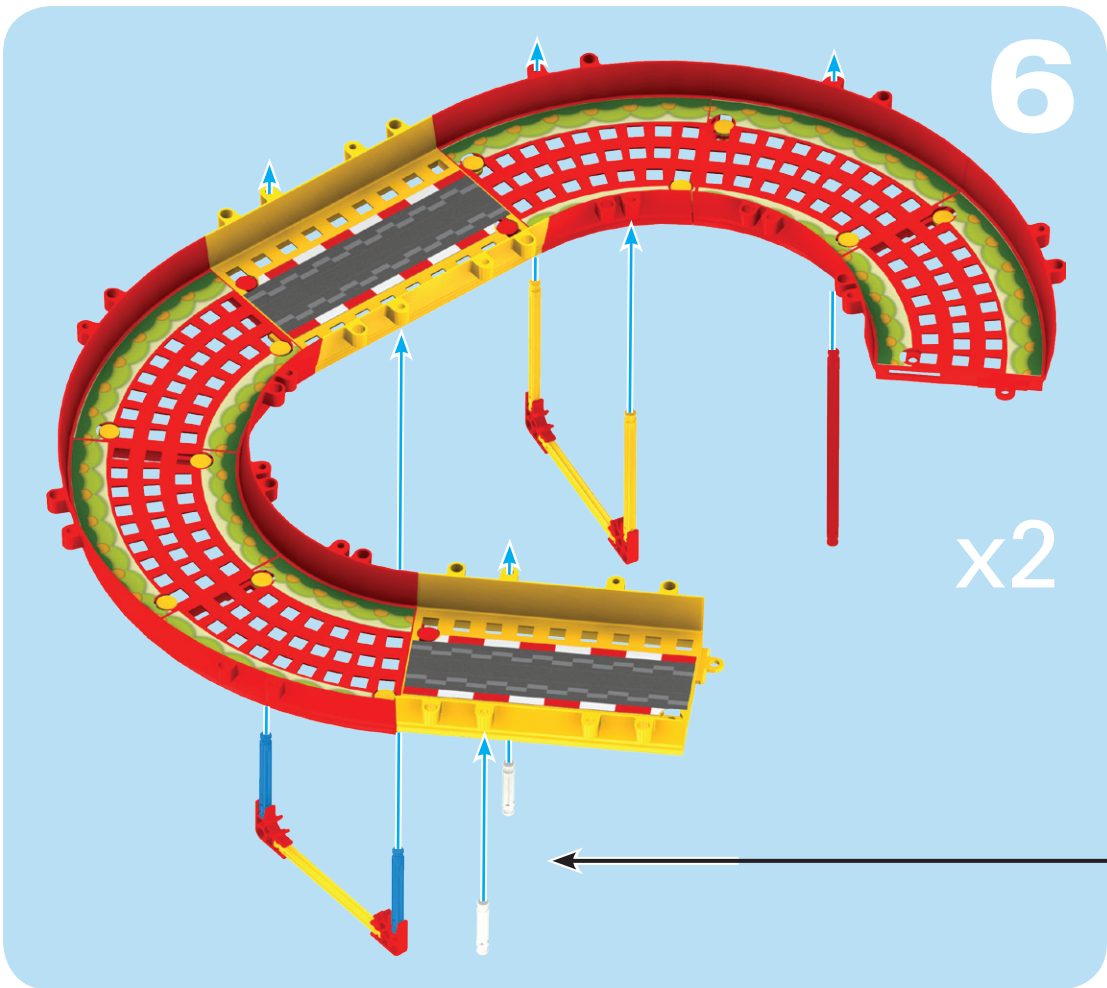

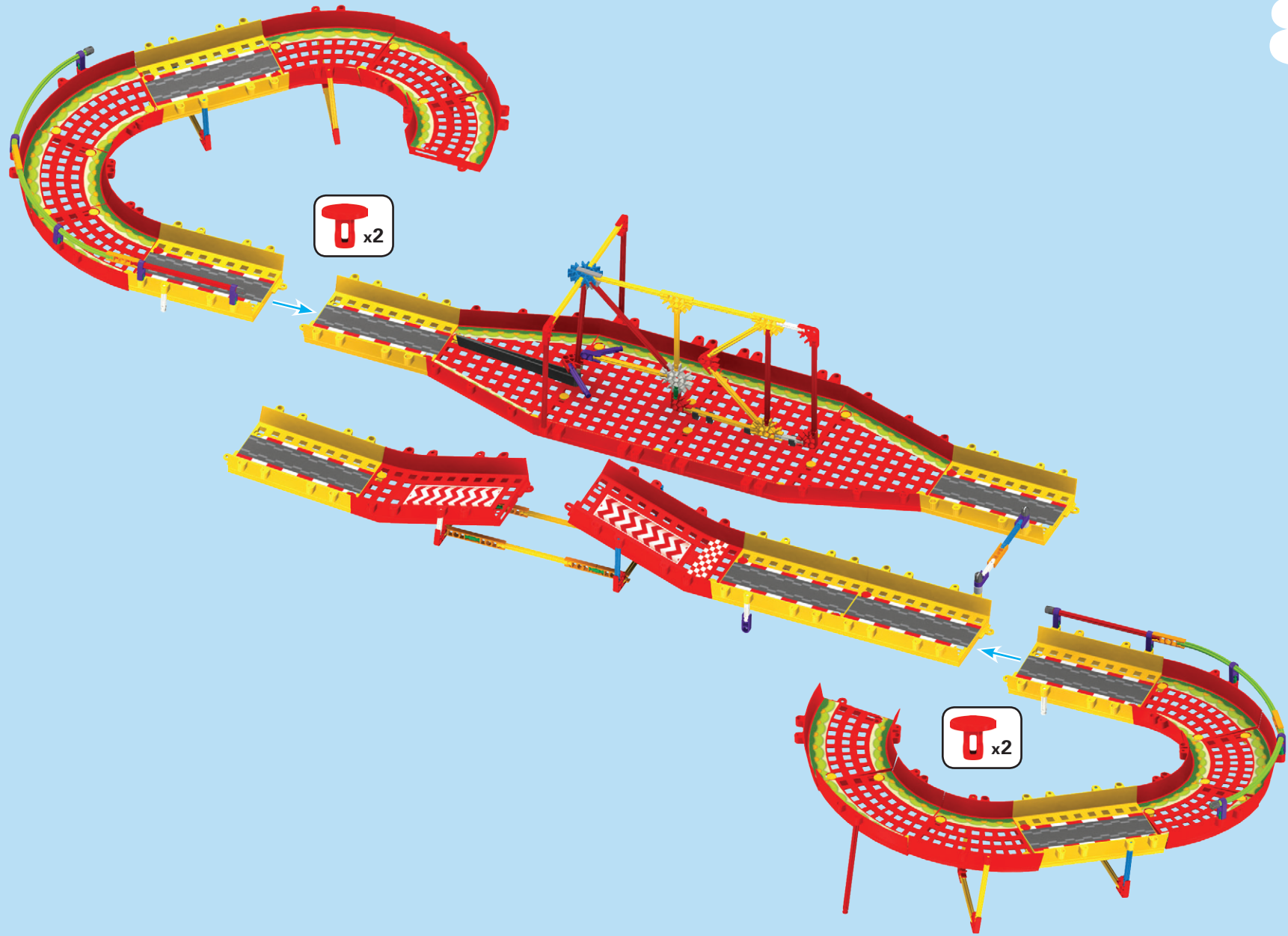

1

D

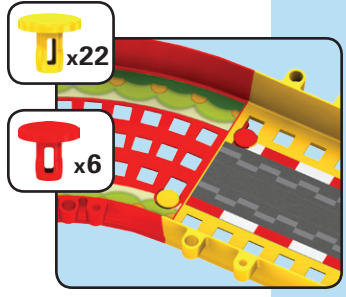

- J Apply stickers
- R Appelez des autocollants
- S Aplicar pegatinas
- D Anbringen von Aufklebern
- I Applicare gli adesivi
- P Aplicar adhesivos
- L Aanbrengen stickers

x2

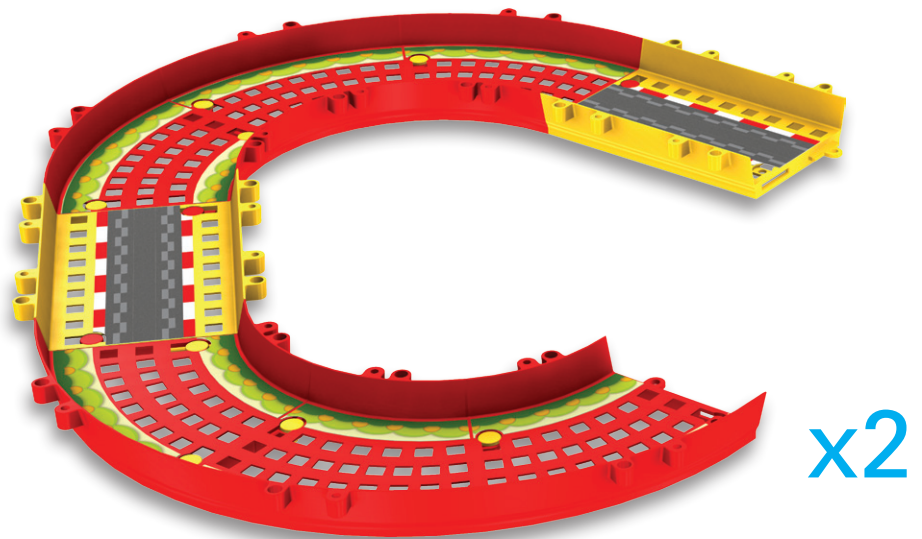

x2

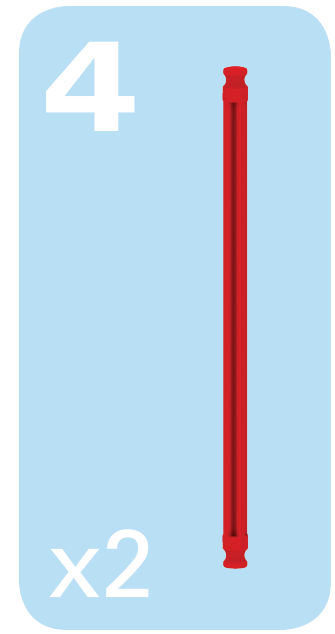
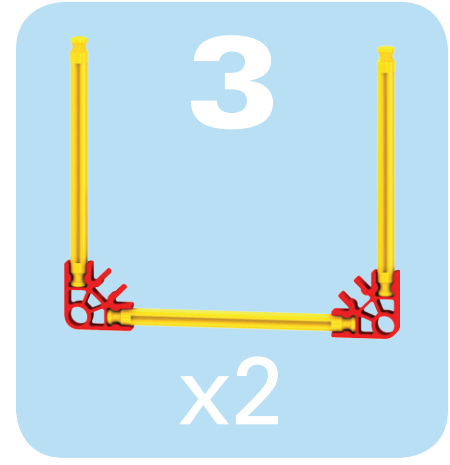
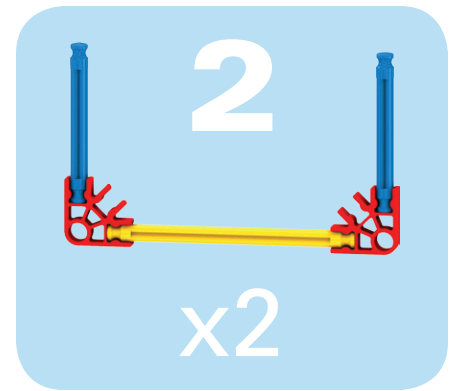

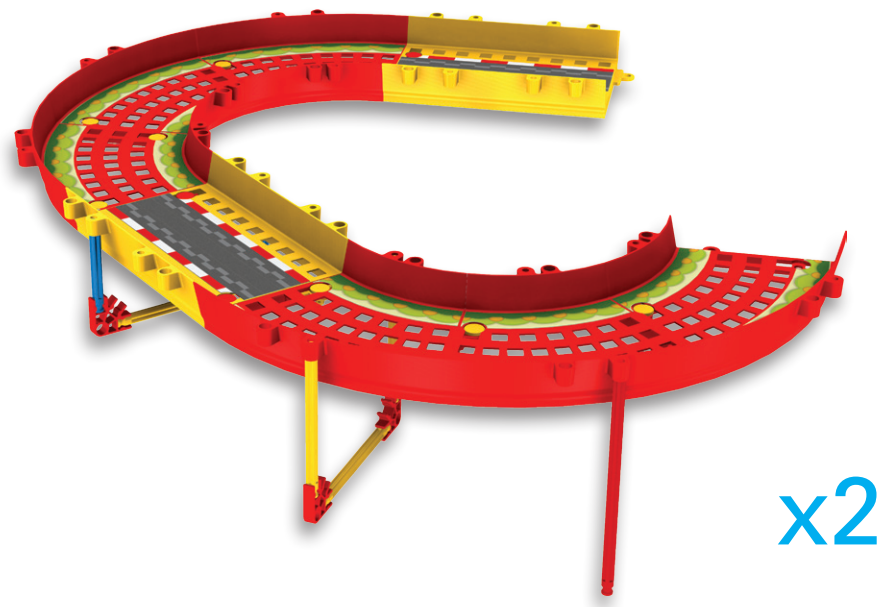
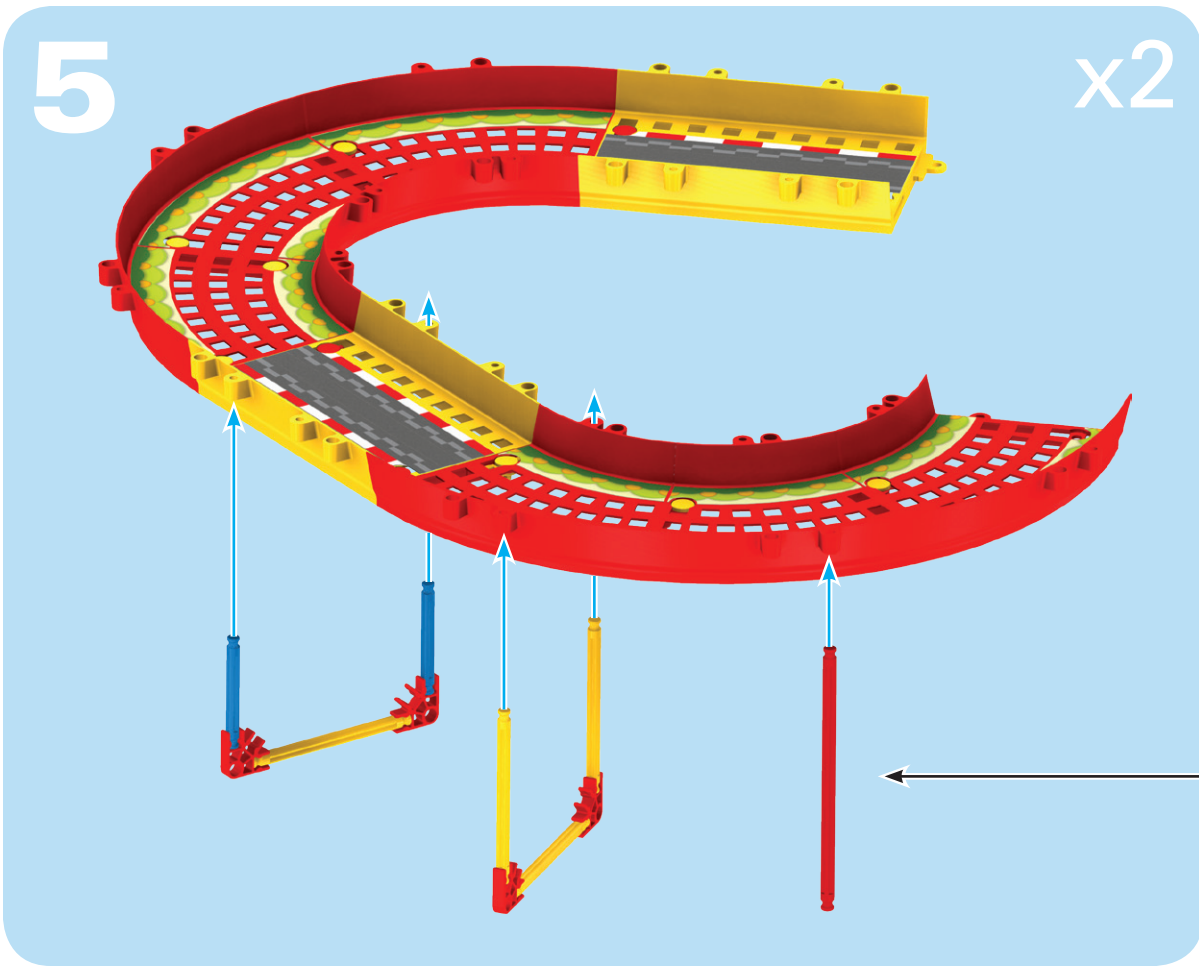

x2

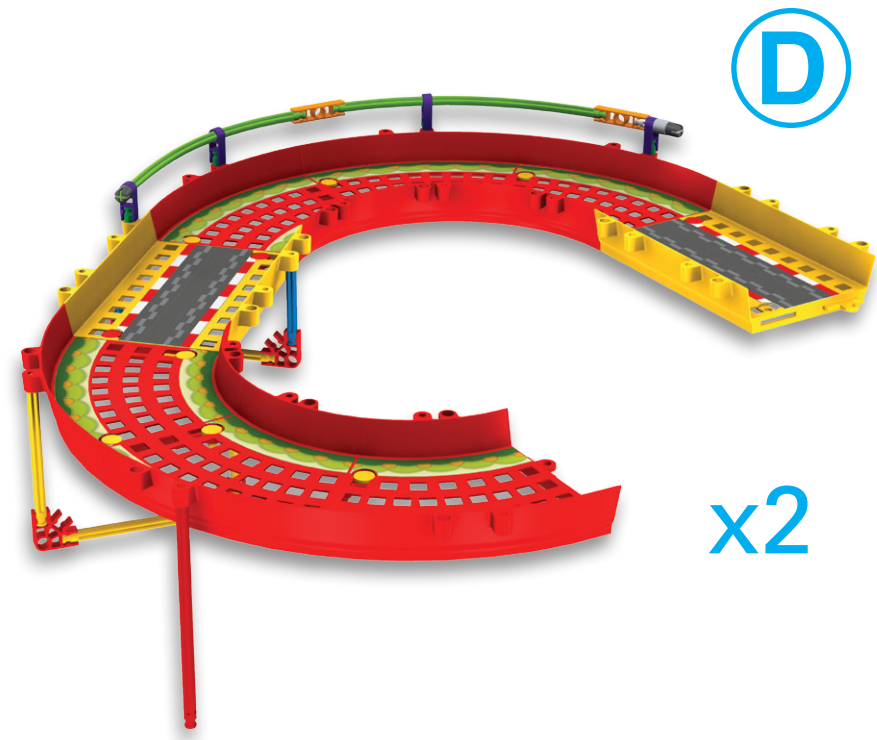
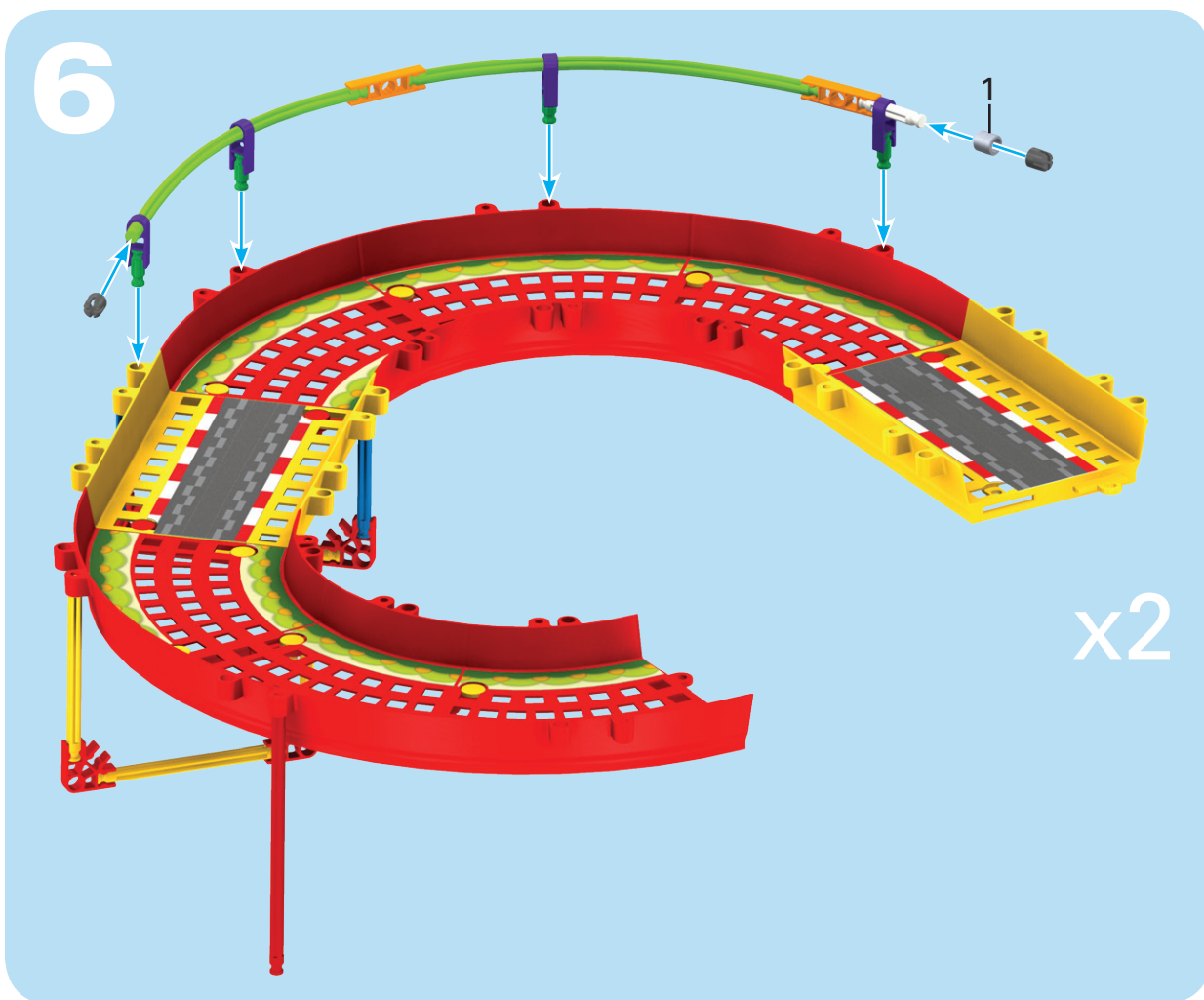
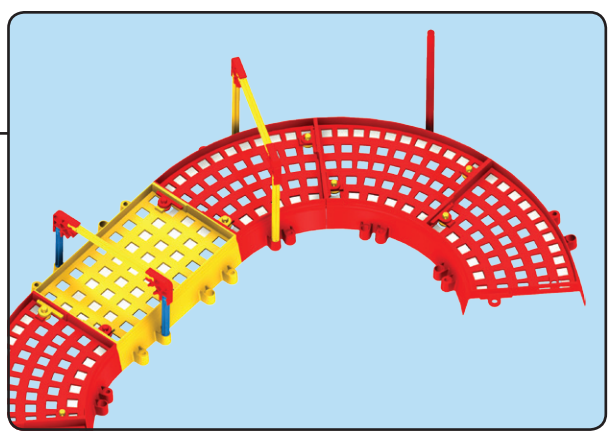

7

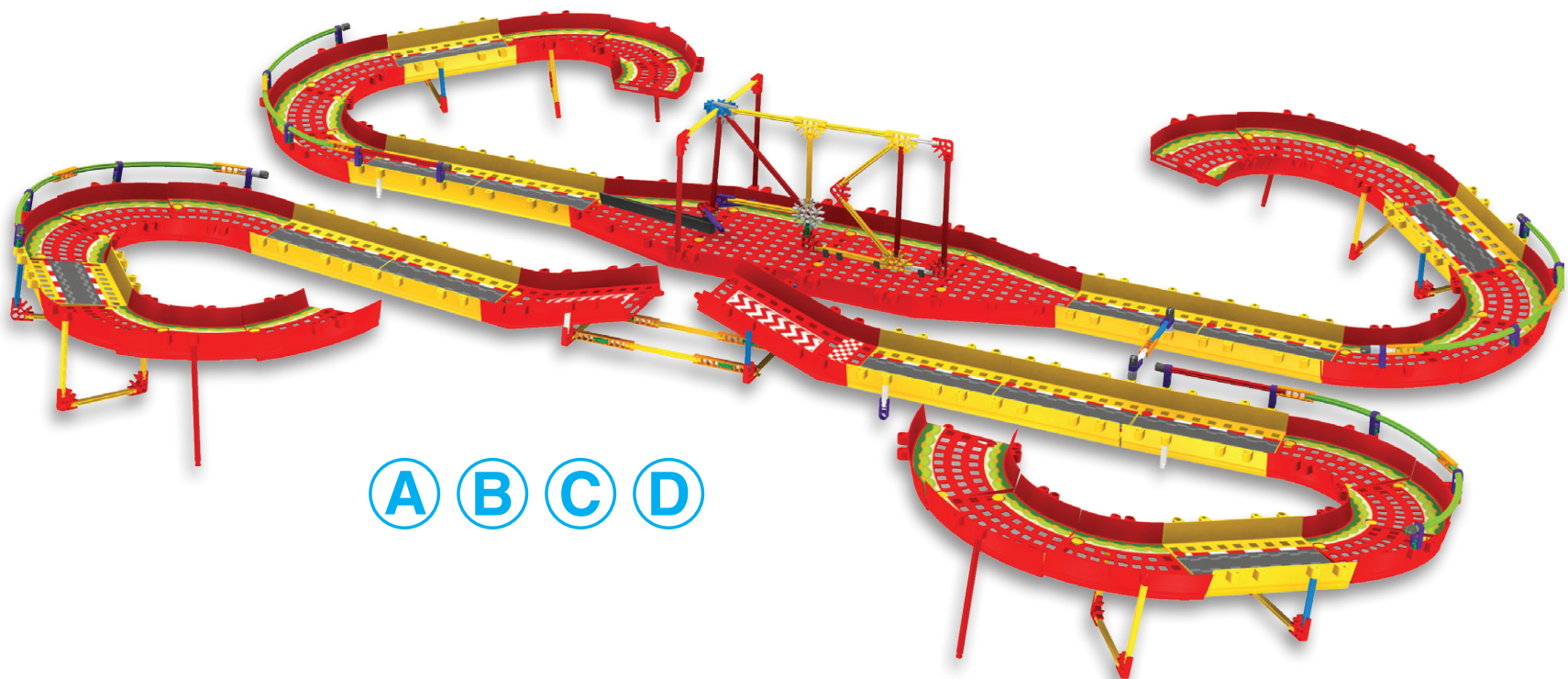
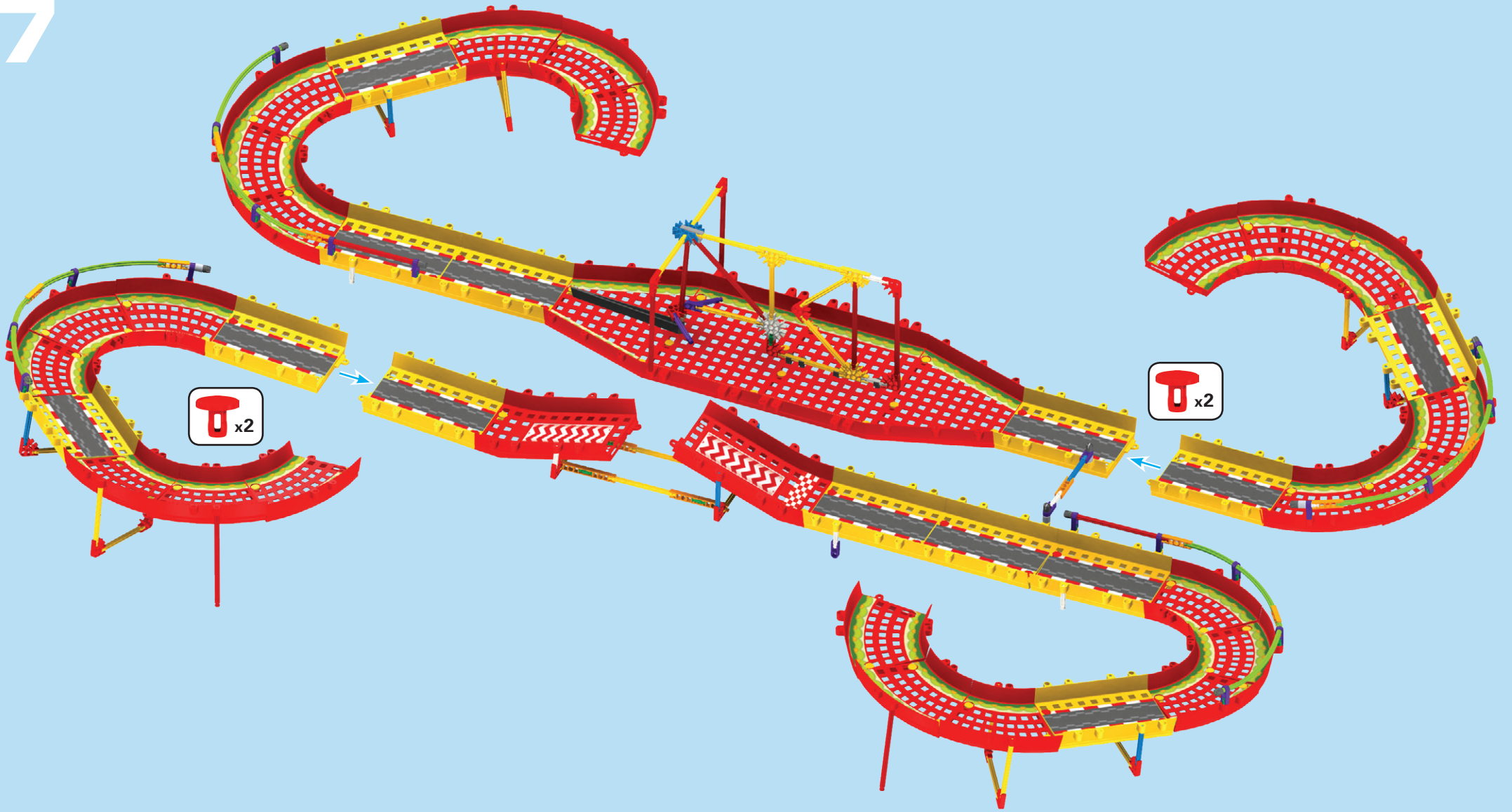

1

x2

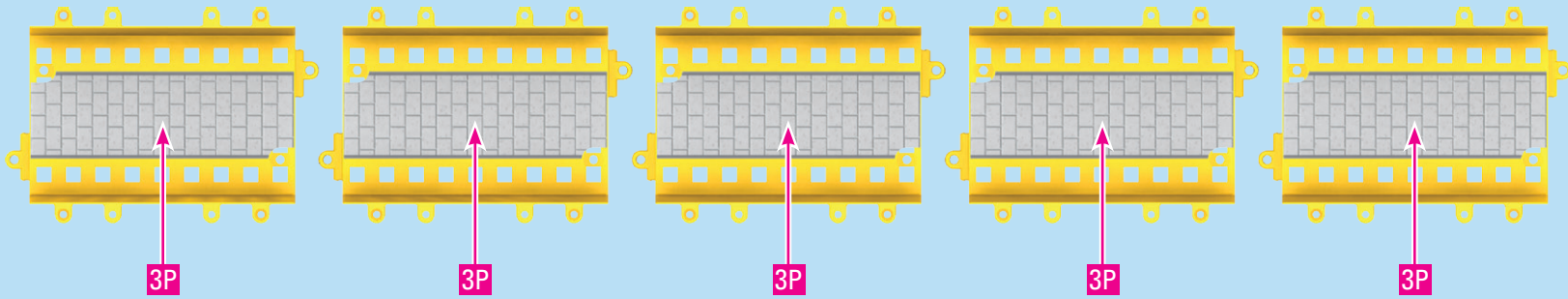

E

2

x4

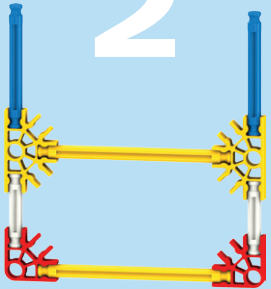

T x16

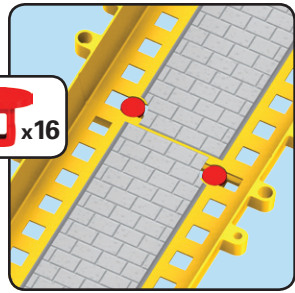

- Apply stickers
- Appelez des autocollants
- Aplicar pegatinas
- Anbringen von Aufklebern
- Applicare gli adesivi
- Aplicar adesivos
- Aanbrengen stickers

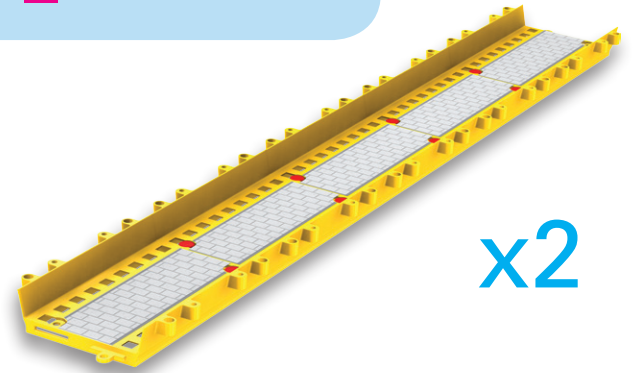

x2

3

x4

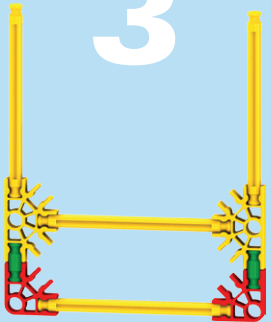

4

x2

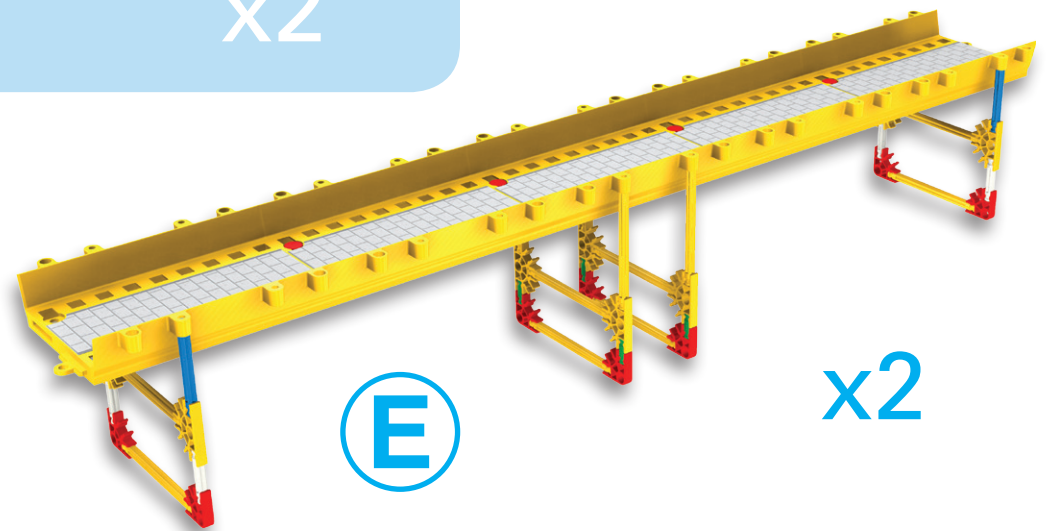
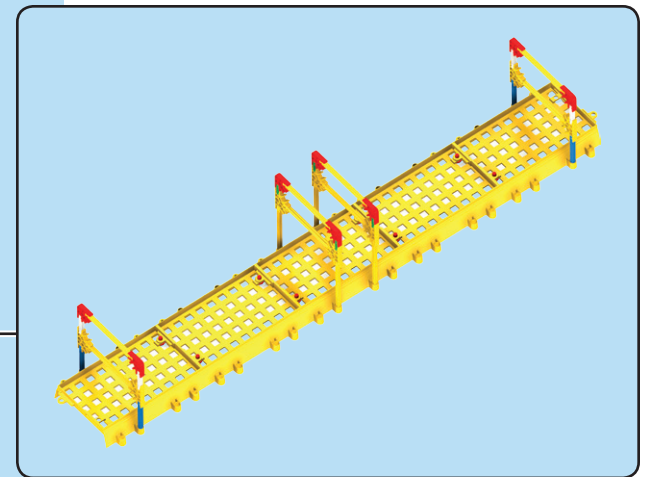
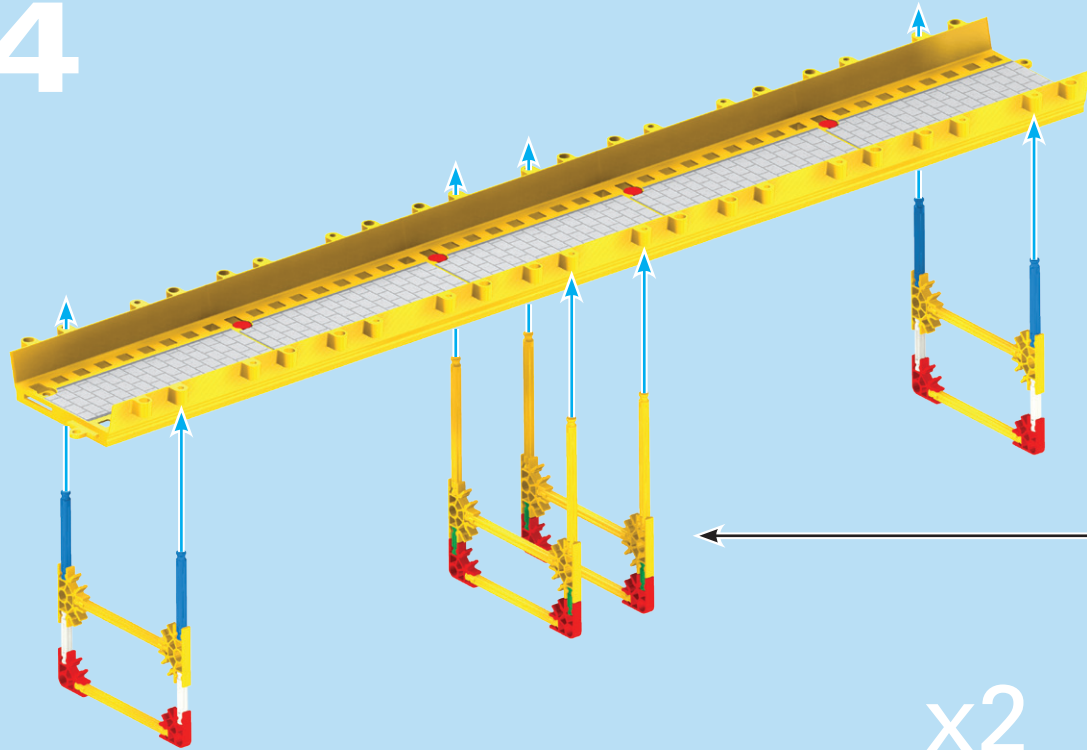

x2

E

5

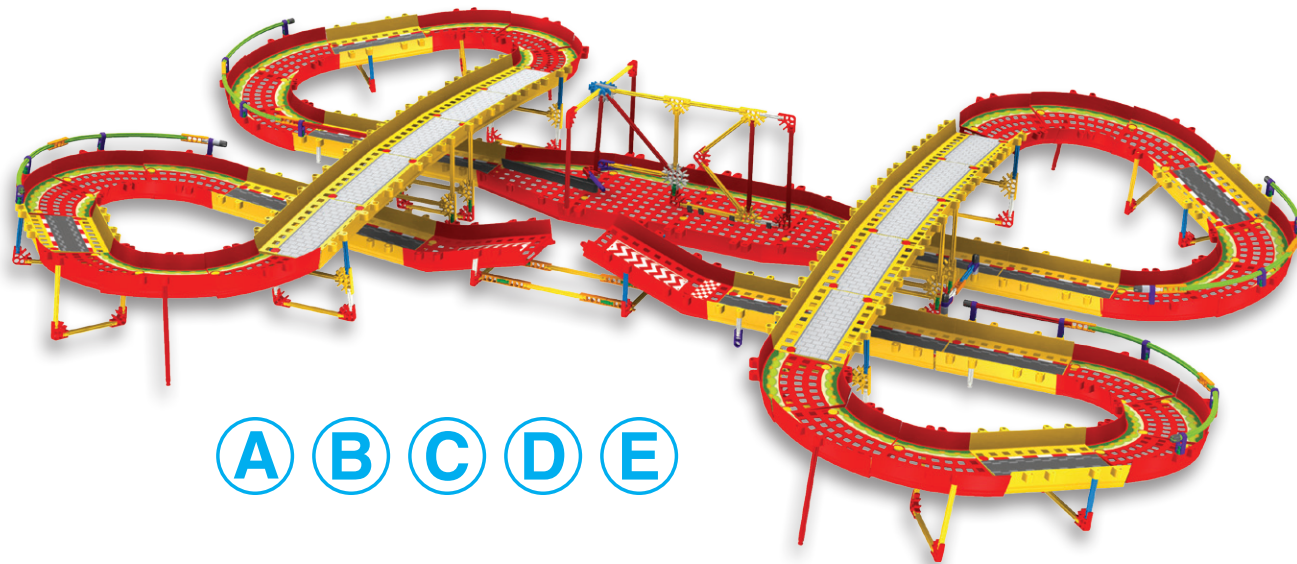
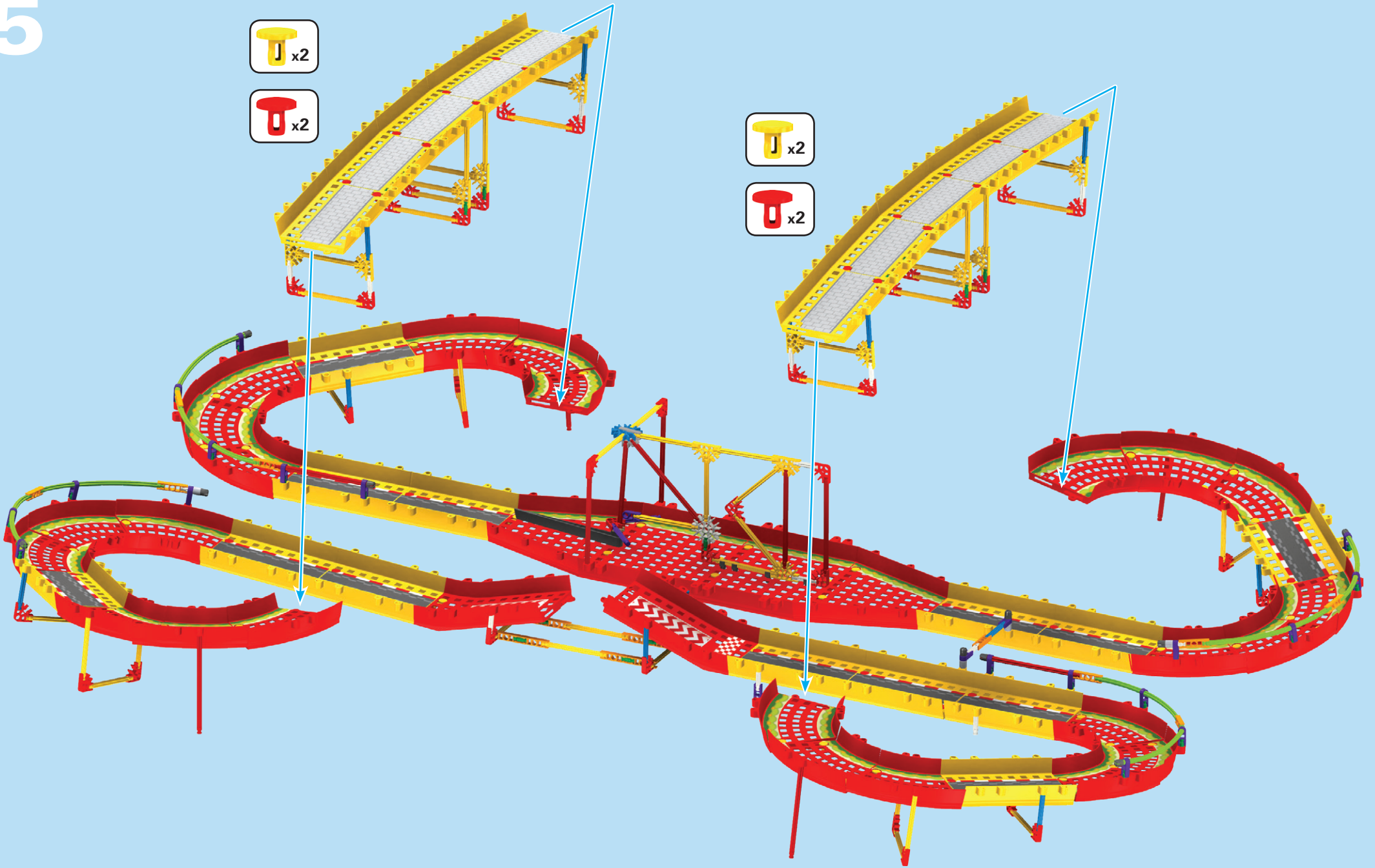
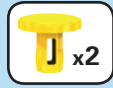

1

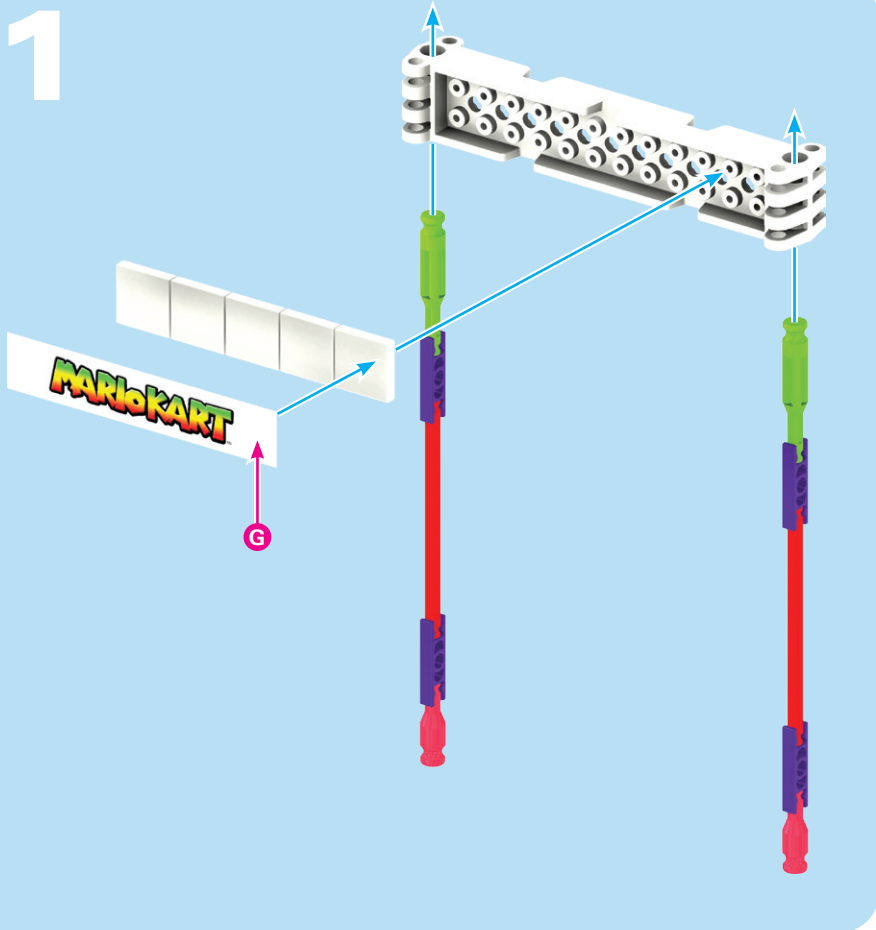

2

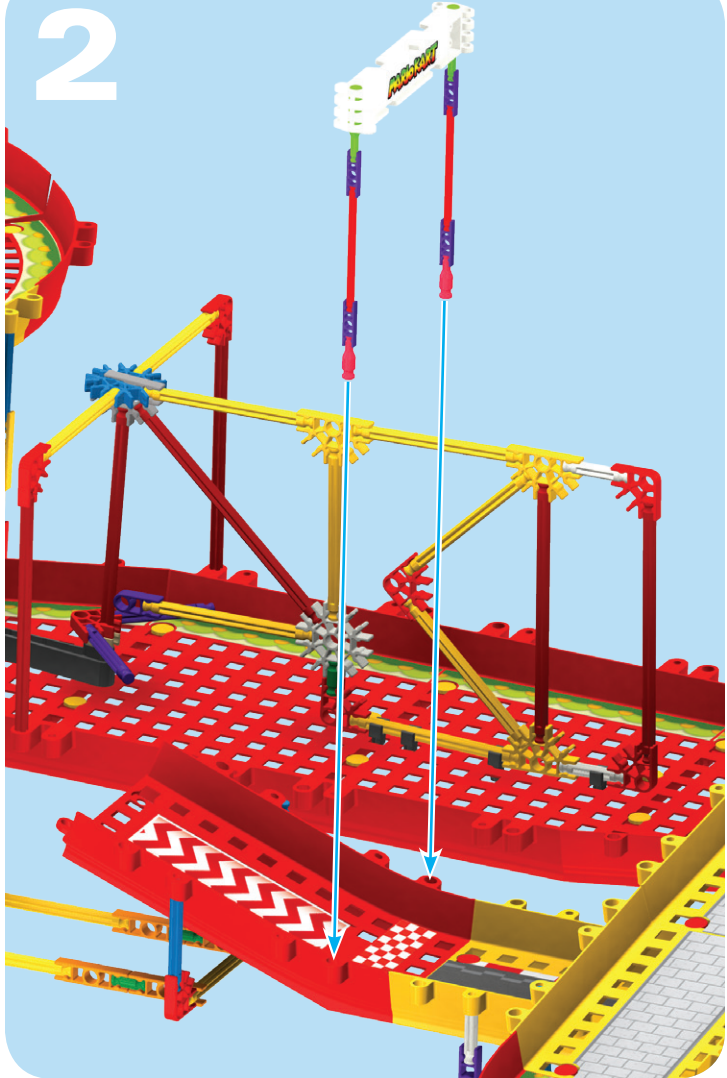

1

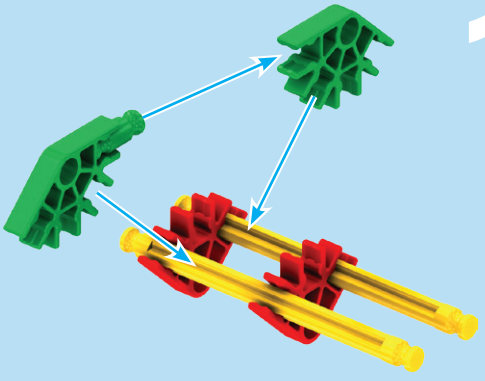

2

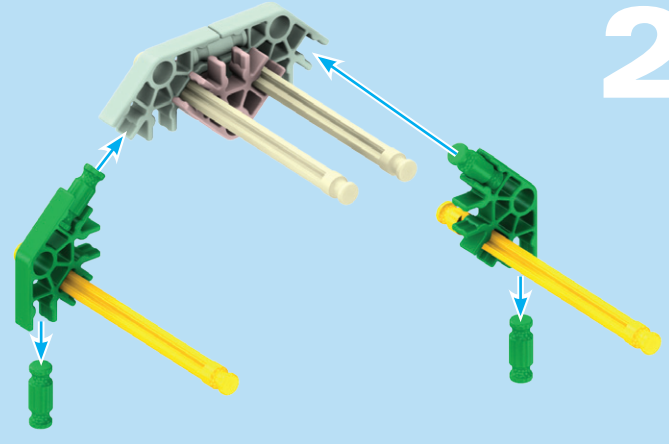

3

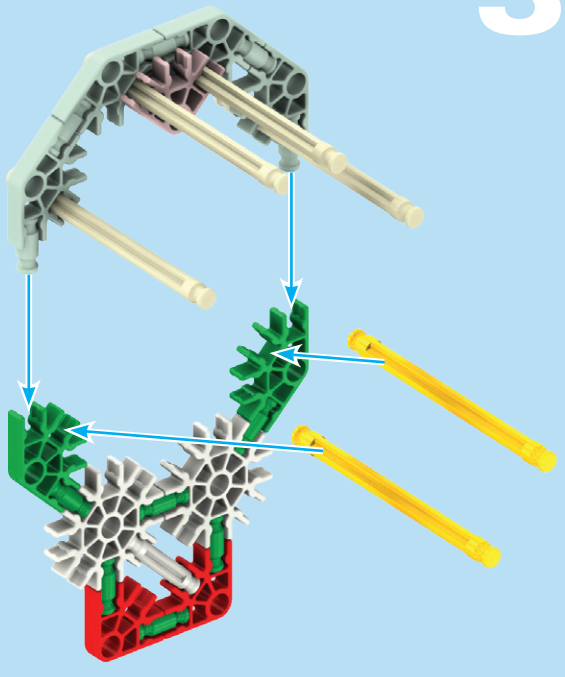

4

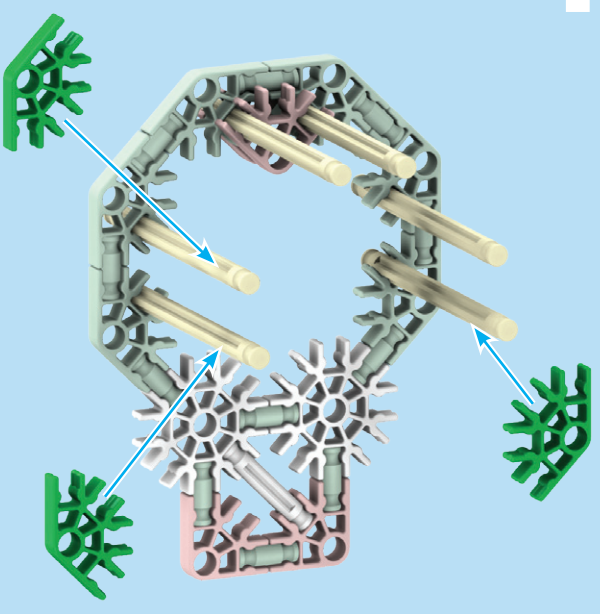

5

 x1

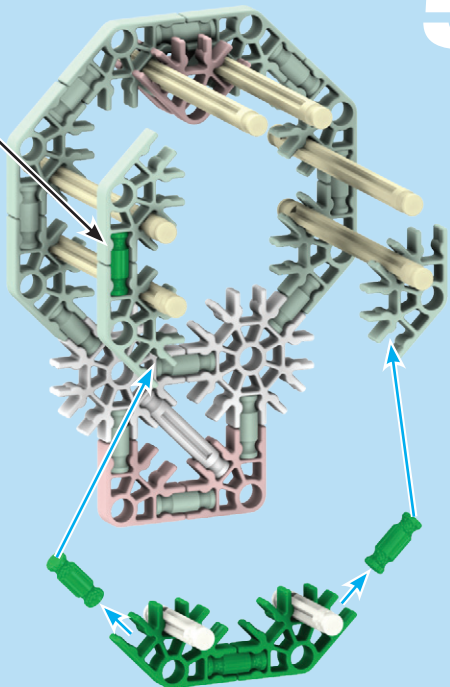

6

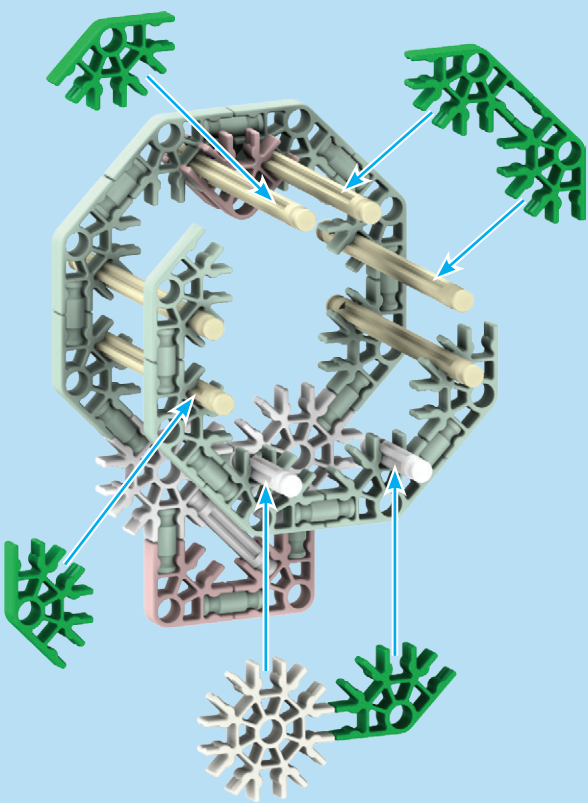

7

 x7

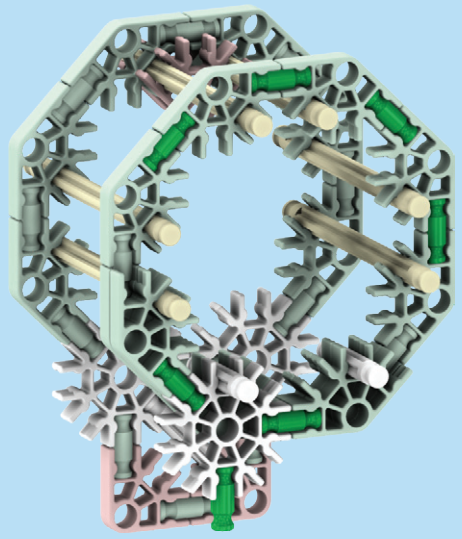

8

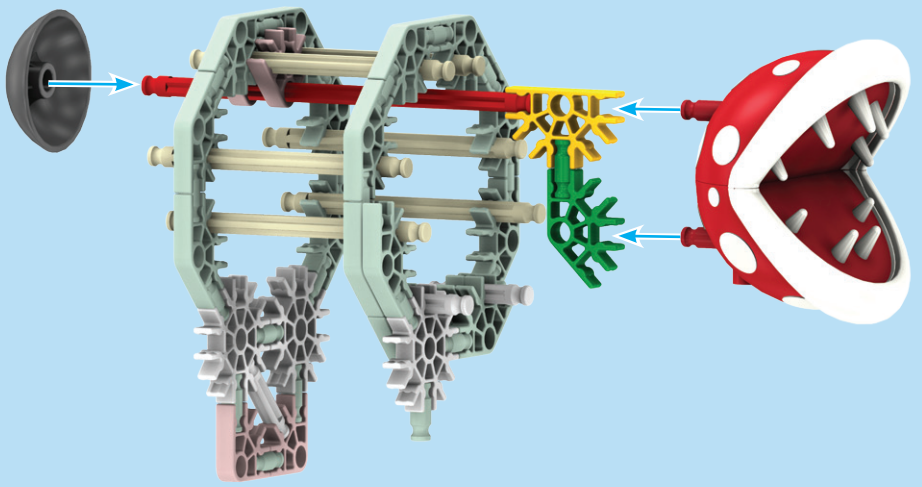

9



1

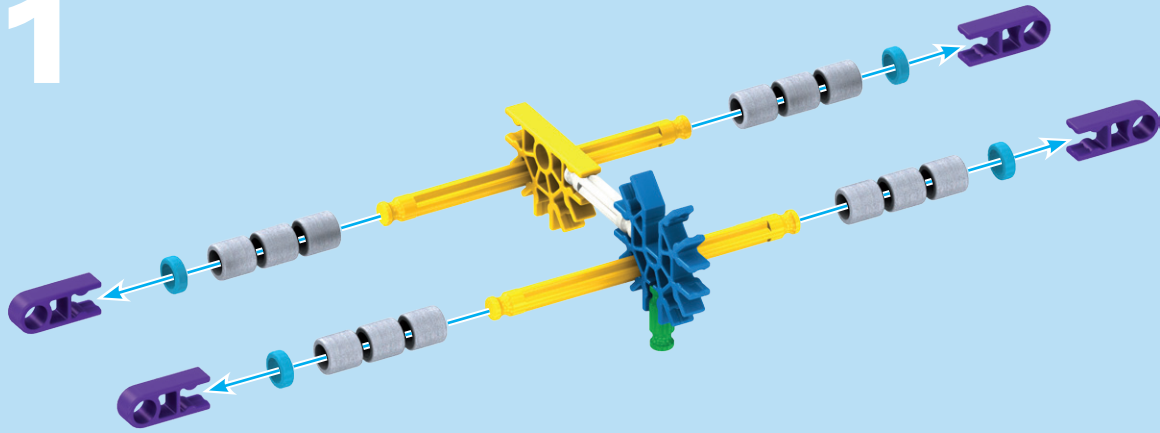

2

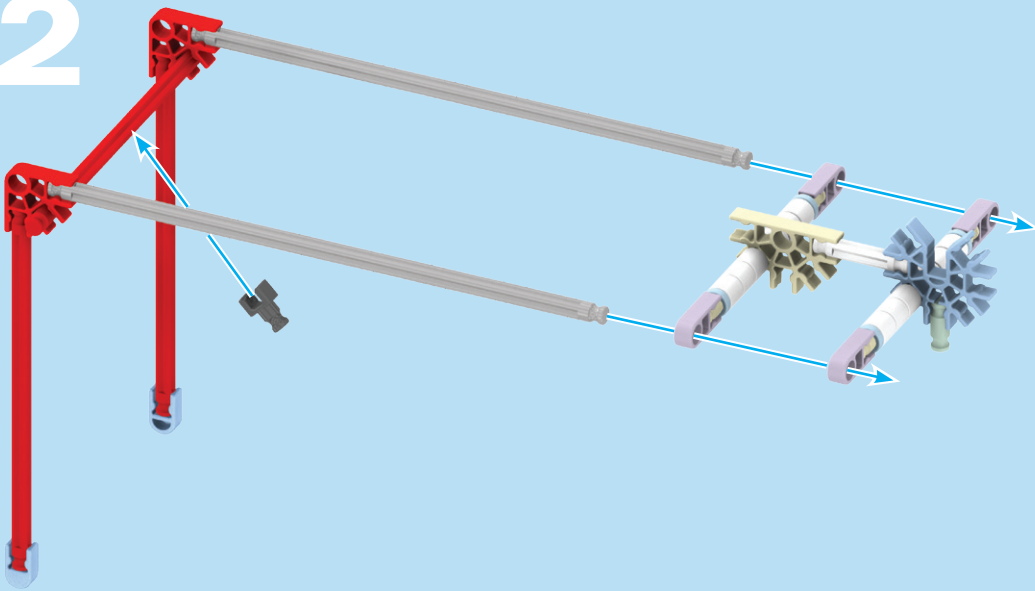

3



- Ⓔ Be sure to attach all the chain links in the same direction.
- Ⓕ Assure-toi de fixer tous les maillons de la chaîne dans le même sens.
- Ⓖ Asegúrate de fijar todos los elementos de la cadena en la misma dirección.
- Ⓓ Achte darauf, alle Kettenglieder in der gleichen Richtung zu verbinden.
- Ⓜ Accertati di attaccare tutti i collegamenti della catena nella stessa direzione.
- Ⓟ Assegura-te que prendes todos os elos da corrente seguindo a mesma direcção.
- Ⓝ Zorg ervoor dat alle schakels in dezelfde richting te bevestigen.

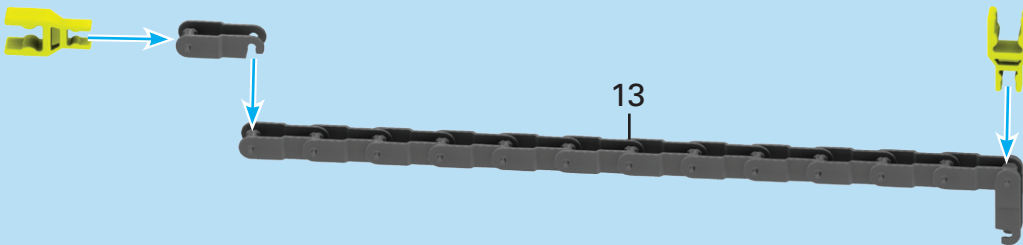

13

4

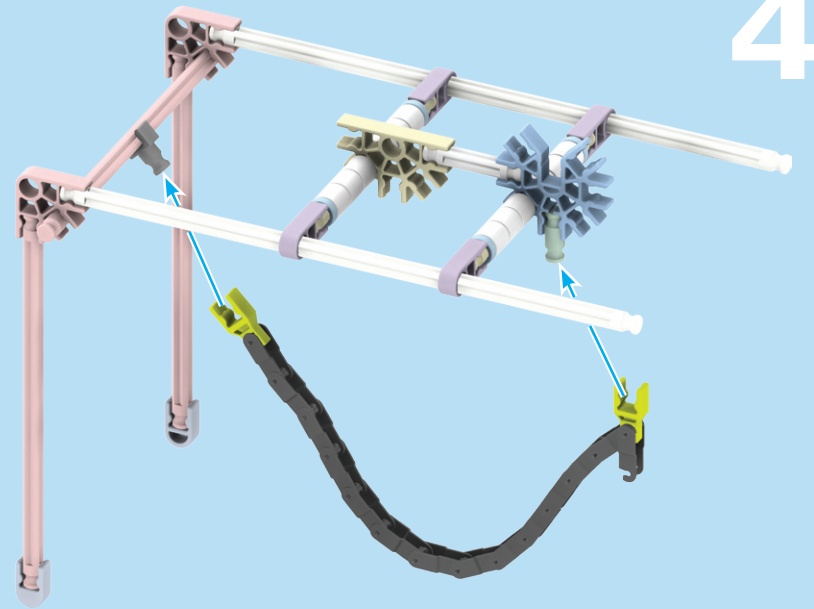

5

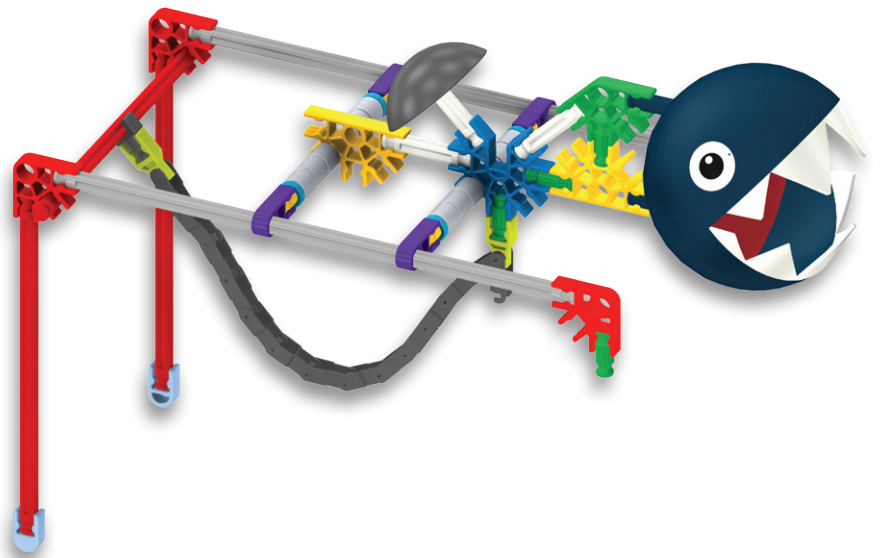
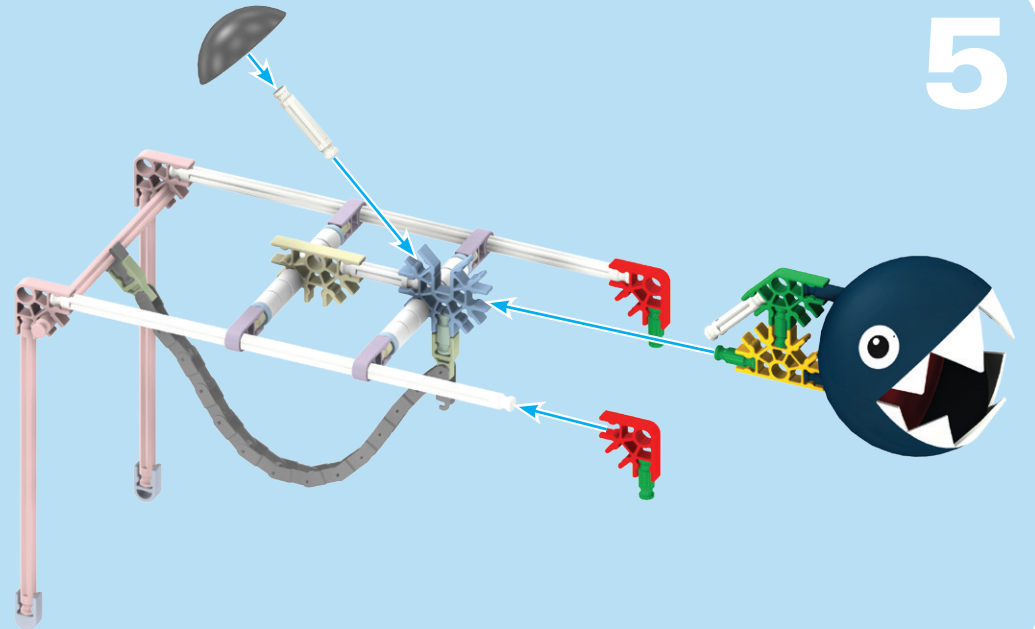

6

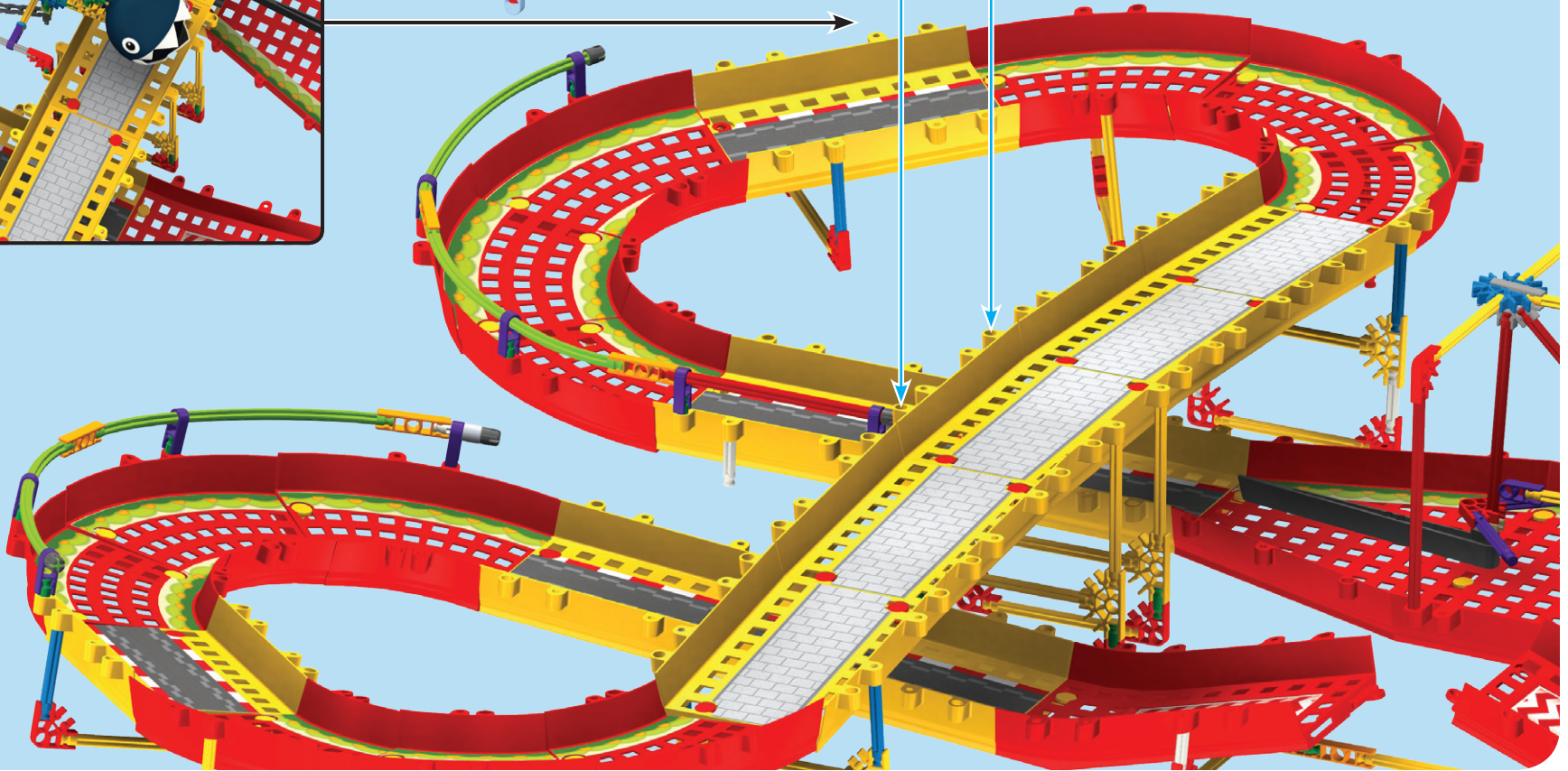
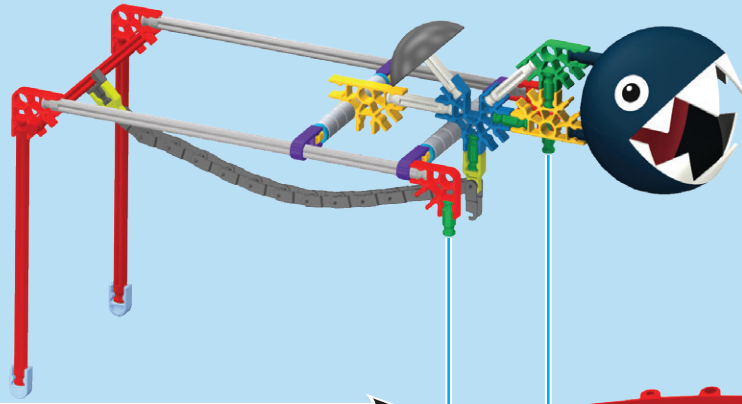
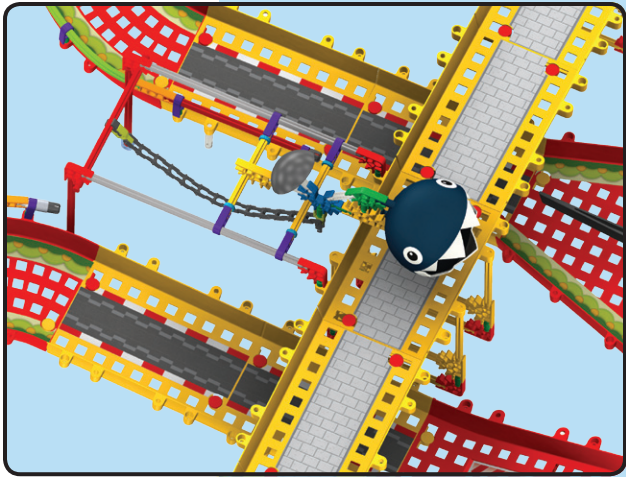

1

x2

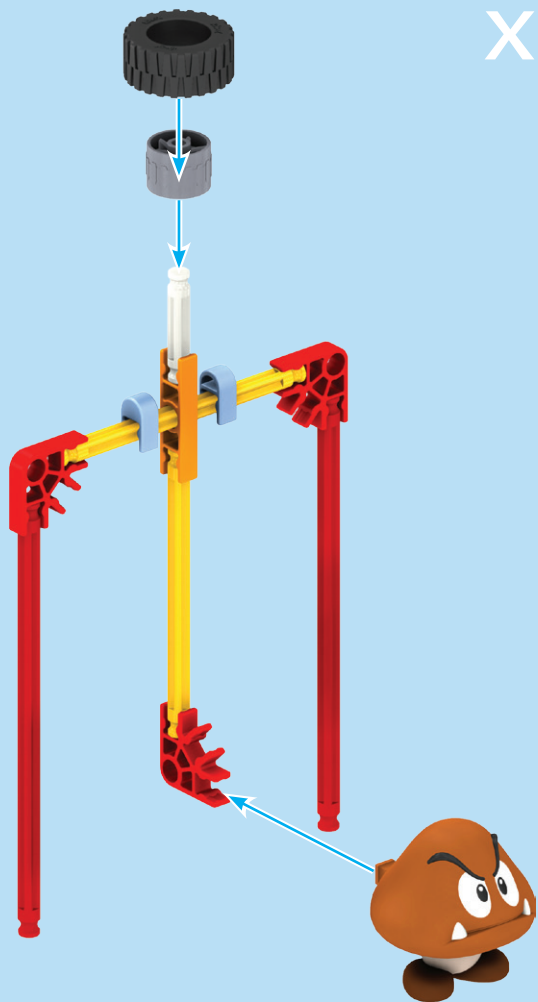

2



x2

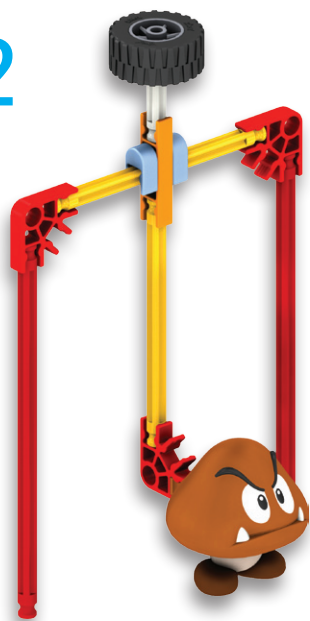

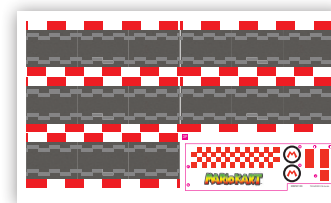
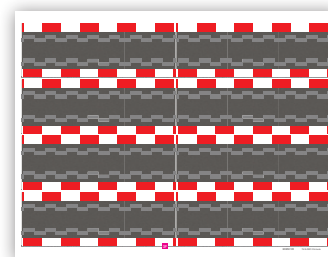
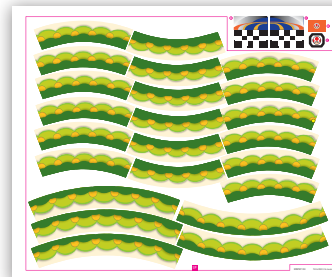
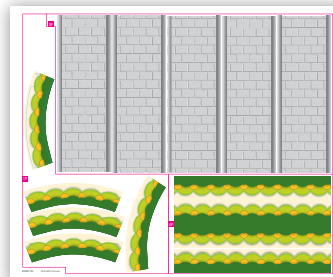
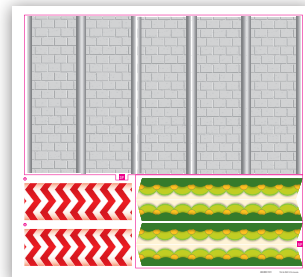
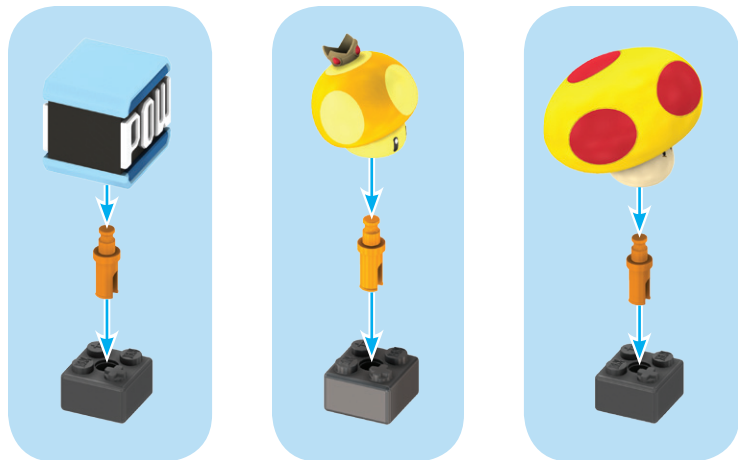

MARIO™ CIRCUIT

ULTIMATE BUILDING SET

ULTIME JEU DE CONSTRUCTION



MARIO KART™ Wii

Collect all the Mario Kart™ Wii building sets to create your own tracks!
Rassemblez tous les ensembles de bâtiment de Mario Kart™ Wii pour créer vos propres voies!
¡Recoja todos los sistemas del edificio de Mario Kart™ Wii para crear sus propias pistas!



TM & © 2012 Nintendo.



* Sold separately. Some products may not be available in all markets.
Vendus séparément. Certains produits ne sont pas disponibles pour tous les marchés.
Se venden por separado. Algunos productos no pueden estar disponibles en todos mercados.

www.knex.com/mariokartwii



KNEX.COM

K'NEX is a registered trademark of K'NEX Limited Partnership Group. Product & colors may vary. (FR) K'NEX est une marques déposée de K'NEX Limited Partnership Group. Produits et couleurs peuvent varier. (ES) K'NEX es una marca registrada de K'NEX Limited Partnership Group. El producto y los colores pueden variar.

©2012 K'NEX Limited Partnership Group, P.O. Box 700, Hatfield, PA 19440-0700; email@knex.com; www.knex.com; 1-800-KID-KNEX (USA/Canada/États-Unis/EE.UU.) Customer outside the USA & Canada contact your local distributor at www.knex.com/distributors. (FR) Le Service clients hors États-Unis et Canada, s'il vous plaît contacter le distributeur local. L'information de distributeur peut être trouvée à www.knex.com/distributors. (ES) El cliente que no vive en EE.UU. y Canadá se pone en contacto con el distribuidor local. Encuentre la información para el distribuidor local en www.knex.com/distributors.(DE)(FR)(NL)(UK) www.tomy.eu. (UK) TOMY Careline, PO Box 20, Totton, Hants, SO40 3YF, England; Tel 023 8066 2600. (FR) ALLO TOMY SAV, Parc d'affaires international, 74166 ARCHAMPS, France ; Tél 0 820 013 013.

- Identifies Genuine K'NEX Bricks.
- Identifie que ce sont d'authentiques briques K'NEX.
- Identifica los ladrillos genuinos de K'NEX.
- Identifiziert echte K'NEX-Bausteine.
- Edentifica i veri blocchi K'NEX.
- Identifica que são cubos genuínos da K'NEX.
- Identificeert K'NEX bakstenen voor.



 facebook.com/buildknex

138501-V2-09/12

