

inventor's CLUBHOUSE

CLUBHOUSE

de l'inventeur



(EN) Keep this important information for future reference.
(FR) Gardez précieusement cette notice pour t'y référer ultérieurement.
(ES) Guarde esta información importante para futuras referencias.
(DE) Informationen für später aufbewahren.
(IT) Conservare queste importanti informazioni per riferimento futuro.
(PT) Manter esta informação importante para referência futura.
(NL) Bewaar deze belangrijke informatie, zodat u deze in de toekomst opnieuw kunt raadplegen.

(EN) **WARNING:** Not suitable for children under 18 months. Long cord/Long chain. Strangulation hazard.
(FR) **AVERTISSEMENT :** Ne convient pas aux enfants de moins de 18 mois. Longue corde/Longue chaîne. Risque d'étranglement.
(ES) **ADVERTENCIA:** No adecuado para niños menores de 18 meses. Cable largo/cadena larga. Peligro de estrangulamiento.
(DE) **ACHTUNG:** Nicht geeignet für Kinder unter 18 Monate. Lange Schnur / Lange Kette. Strangulierungsgefahr.
(IT) **AVVISO:** Non adatto a bambini di età inferiore a 18 mesi. Cavo lungo / lunga catena. Rischio di strangolamento.
(PT) **AVISO:** Não recomendado para menores de 18 meses. Cabo longo / cadeia longa. Perigo de estrangulamento.
(NL) **WAARSCHUWING:** Niet geschikt voor kinderen onder de 18 maanden. Lang snoer / lange keten. Gevaar voor worging.

 **WARNING:** CHOKING HAZARD – Small parts. Not for children under 3 years.
ATTENTION : RISQUE D'ÉTOUFFEMENT – Pièces de petite taille. Ne convient pas aux enfants de moins de 3 ans.
ADVERTENCIA: PELIGRO DE ASFIXIA – Piezas pequeñas. No para niños menores de 3 años.
ACHTUNG: ERSTICKUNGSGEFAHR – Kleinteile. Nicht geeignet für Kinder unter 3 Jahren.
AVVISO: PERICOLO DI SOFFOCARE – Pezzi piccoli. Non adatto per bambini sotto 3 anni.
AVISO: PERIGO DE SUFOCAÇÃO – Peças pequenas. Não se destina a crianças com menos de 3 anos de idade.
WAARSCHUWING: INSLIKKINGSGEVAAR – Kleine onderdelen. Niet geschikt voor kinderen jonger dan 3 jaar.

CAUTION: Keep hands, face, hair and clothing away from all moving parts.
ATTENTION : Gardez les cheveux, les doigts, la figure et les vêtements à l'écart de toutes les pièces mobiles.
PRECAUCIÓN: Mantén el cabello, los dedos, la cara y la ropa alejada de las piezas móviles.
VORSICHT: Haare, Finger, Gesicht und Kleidungsstücke nicht mit beweglichen Teilen in Berührung kommen lassen.

ATTENZIONE: Tenere i capelli, le dita, il viso e i vestiti lontano da tutte le parti in movimento.
CUIDADO: Mantém o cabelo, os dedos, a cara e a roupa afastados de todas as peças móveis.
OPGEPAST: Hou het haar, de vingers, het gezicht en kledij verwijderd van alle bewegende onderdelen.

(EN) Battery Information

CAUTION: To Avoid Battery Leakage

- Be sure to insert the batteries correctly and always follow the toy and battery manufacturers' instructions.
- Do not mix old and new batteries or alkaline, standard (carbon-zinc) or rechargeable (nickel-cadmium) batteries. Only batteries of the same or equivalent type recommended should be used.
- Always remove weak or dead batteries from the product; do not short-circuit supply terminals.
- Insert batteries with correct polarity (+/-) as shown.

Important Tips

- Alkaline batteries are recommended.
- Rechargeable batteries are not recommended.
- Remove rechargeable batteries from toy before charging; they must be charged only under adult supervision.
- Non-rechargeable batteries must not be recharged.
- Keep components free of dust; do not immerse or use in water.
- Do not dispose of batteries in a fire; they could leak or explode and cause injury.
- Remove all batteries if the toy will not be used for a long period of time.

 The wheeled bin indicates this product cannot be disposed of with household waste due to presence of hazardous substances. To protect human health and environment, check your local authority for recycling advice and facilities, Europe only.

How to Insert and Remove Batteries

Use a small Phillips head screwdriver to loosen the screw. Insert 2 fresh AA batteries** (LR6) into the compartment with the correct polarity (+/-) as shown here. **Not included

(FR) Informations Pile

ATTENTION : Pour éviter la fuite des piles

- S'assurer d'installer les piles correctement et de suivre toujours les directives des fabricants du jouet et des piles.
- Ne pas mélanger des piles neuves avec des piles usées. Ne pas mélanger des piles alcalines avec des piles standard (Leclanché), ou des piles rechargeables (au nickel-cadmium). Il convient d'utiliser uniquement des piles du type recommandé ou d'un type équivalent.
- Retirer toujours les piles faibles ou mortes du produit ; ne pas faire court-circuiter les bornes.
- Installer les piles en respectant la polarité (+/-) comme l'indique le schéma.

Conseils importants

- Les piles alcalines sont recommandées.
- Il est déconseillé d'utiliser des piles rechargeables.
- Retirer les piles rechargeables du jouet avant de les recharger; elles doivent être chargées exclusivement en présence d'un adulte.
- Les piles qui ne sont pas rechargeables ne doivent pas être rechargées.
- Veiller à ce que les éléments restent à l'abri de la poussière ; ne pas les plonger dans l'eau ; ne pas utiliser dans l'eau.
- Ne pas jeter les piles dans le feu ; elles risqueraient de fuir ou d'exploser et d'entraîner des blessures.
- Retirer toutes les piles si le jouet restera inutilisé pendant longtemps.

 Le symbole "poubelle à roulettes" indique que ce produit ne peut pas être éliminé avec vos déchets ménagers en raison de la présence de substances dangereuses. Afin de protéger votre santé et l'environnement, renseignez-vous auprès de vos autorités locales afin d'obtenir des conseils sur le recyclage et la localisation des installations adaptées, Europe uniquement.

Comment mettre et retirer des piles

Utiliser un petit Phillips tournevis pour desserrer la vis et pour enlever la couverture de batterie. Insérer 2 AA (LR6) batteries** fraîches dans le compartiment de batterie avec la polarité correcte (+/-). ** Non fournies

(ES) Información de la batería

PRECAUCIÓN: Para evitar fugas en las pilas

- Asegúrese de insertar las pilas correctamente y de siempre seguir las instrucciones del fabricante del juguete y de las pilas.
- No mezcle pilas viejas con nuevas, ni pilas alcalinas, estándar (carbón-cinc) o recargables (níquel-cadmio). Se debe usar solamente pilas del mismo tipo, o las que se recomiendan como equivalentes.
- Siempre retire las pilas débiles o gastadas del producto; no forme cortocircuito en los puntos de intercambio.
- Inserte las pilas de acuerdo con los esquemas de polaridad (+/-).

Consejos importantes

- Se recomiendan las pilas alcalinas.
- No se recomiendan las pilas recargables.
- Retire las pilas recargables del juguete antes de cargarlas; éstas deben ser cargadas solamente bajo la supervisión de un adulto.
- No se debe recargar las pilas que no son recargables.
- Mantenga los componentes sin polvo; no sumerja ni use en agua.
- No deseches las pilas en el fuego ya que pueden tener fugas, explotar y causar lesiones personales.
- Retire todas las pilas si el juguete no se usará por mucho tiempo.

 El contenedor de basura indica que este producto no puede desecharse con la basura doméstica debido a la presencia de sustancias peligrosas. Para proteger la salud humana y el medio ambiente consultar con la agencia local para el consejo y las facilidades de reciclaje, solo Europa.

Cómo insertar y quitar las pilas

Utilizar un pequeño destornillador principal Phillips para aflojar el tornillo y para quitar la cubierta de batería. Insertar 2 AA (LR6) baterías* frescas en el compartimento de batería con la polaridad correcta (+/-). * No se incluyen

(DE) Informationen zu den Batterien

VORSICHT: Um ein Auslaufen der Batterien zu vermeiden

- Achte darauf dass die Batterien korrekt einglegt werden und folge den Anweisungen der Spielzeug- und Batteriefabrikanten.
- Mische keine alten und neuen Batterien oder alkaline Batterien, Standardbatterien (Kohle-Zink) oder wiederaufladbare Batterien (Nickel-Cadmium). Verwende nur Batterien des gleichen Typs oder des empfohlenen äquivalenten Typs.
- Leere oder verbrauchte Batterien aus dem Spielzeug entfernen; darauf achten, dass die Pole der Batterie nicht kurzgeschlossen werden.
- Beim Einlegen der Batterien auf die korrekte Polarität (+/-), wie dargestellt, achten.

Wichtige Tipps

- Alkaline Batterien werden empfohlen.
- Wiederaufladbare Batterien sind nicht empfohlen.
- Bei Verwendung von wiederaufladbaren Batterien müssen diese aus dem Spielzeug entfernt werden, bevor sie wieder aufgeladen werden; das Wiederaufladen darf nur unter Aufsicht eines Erwachsenen stattfinden.
- Nichtwiederaufladbare Batterien dürfen nicht wieder aufgeladen werden.
- Die Komponenten von Staub freihalten; nicht in Wasser tauchen.
- Zu entsorgende Batterie nicht ins Feuer werfen; sie können auslaufen oder explodieren und Körperverletzungen verursachen.
- Wenn das Spielzeug längere Zeit nicht verwendet werden soll, alle Batterien entfernen.

 Der Abfallbehälter zeigt an, dass dieses Produkt aufgrund von Gefahrstoffen nicht im normalen Hausmüll entsorgt werden kann. Zum Schutz von Gesundheit und Umwelt kontaktieren bitte deine lokale Behörden für Recyclingtipps und -einrichtungen, nur Europa.

Anweisungen zum Einlegen und Entfernen der Batterien
Einen kleinen Kreuzkopfschraubenzieher benutzen, um die Schraube zu lösen und die Batterieabdeckung zu entfernen. 2 frische AA (oder LR6) Batterien** in den Batterieraum mit der korrekten Polarität einsetzen (+/-). ** Nicht enthalten

(IT) Informazioni sulle batterie

ATTENZIONE: Come evitare perdite delle batterie

- Accertarsi di inserire le batterie correttamente e seguire sempre le istruzioni del produttore delle batterie e del giocattolo.
- Non mettere insieme batterie nuove e vecchie o alcaline, standard (carbonio-zinco) e ricaricabili (níquel-cadmio). Usare sempre batterie raccomandate dello stesso tipo o di tipo equivalente.
- Rimuovere sempre batterie quasi scariche o completamente scariche dal prodotto; non causare corto circuito ai terminali di alimentazione.
- Inserire le batterie con la polarità corretta (+/-) come illustrato.

Consigli importanti

- Si raccomanda l'uso di batterie alcaline.
- Non si raccomanda l'uso di batterie ricaricabili.
- Rimuovere le batterie ricaricabili dal giocattolo prima della carica: devono essere caricate solo sotto la supervisione di un adulto.
- Le batterie non ricaricabili non devono essere ricaricate.
- Mantenere i componenti privi di polvere; non immergere o usare in acqua.
- Non gettare le batterie nel fuoco, poiché potrebbero perdere o esplodere e causare lesioni.
- Rimuovere tutte le batterie se il giocattolo non verrà usato per un lungo periodo di tempo.

 Il bidone della spazzatura indica che questo prodotto non si può buttare via con i rifiuti domestici a causa della presenza di sostanze pericolose. Per proteggere la salute umana e l'ambiente, devi controllare con la tua autorità locale per consigli e impianti di riciclaggio, solo in Europa.

Come inserire e rimuovere le batterie

Utilizzare un piccolo cacciavite Phillips per allentare la vite e per rimuovere la copertura di batteria. Inserire 2 AA (o LR6) batterie** fresche nello scompartimento di batteria con la polarità corretta (+/-). ** Non incluse

(PT) Informações Sobre as Pilhas

CUIDADO: Para evitar fugas das pilhas

- Certifique-se de que introduz as pilhas correctamente e siga sempre as instruções do fabricante da bateria e do brinquedo.
- Não combine pilhas usadas com pilhas novas, pilhas alcalinas, padrão (carbono-zinco) ou pilhas recarregáveis (níquel-cádmio). Devirão ser usadas apenas pilhas do mesmo tipo ou equivalentes ao tipo recomendado.
- Retire sempre as pilhas fracas ou gastadas do produto; não provoque um curto-circuito nos terminais de alimentação.
- Introduza as pilhas com a polaridade correcta (+/-), conforme se mostra.

Conselhos importantes

- Recomenda-se o uso de pilhas alcalinas.
- Não se recomenda o uso de pilhas recarregáveis.
- Retire as pilhas recarregáveis do brinquedo antes de as carregar; estas pilhas devem ser recarregadas apenas sob vigilância de adultos.
- As pilhas não recarregáveis não devem ser recarregadas.
- Mantenha os componentes livres de poeiras; não mergulhe em água nem use água.
- Não elimine as pilhas queimando-as; estas podem apresentar fugas ou explodir causando lesões.
- Retire todas as pilhas do brinquedo se não tentarem usá-lo durante um longo período de tempo.

 O caixote do lixo indica que este produto não pode ser descartado junto com o lixo doméstico devido à presença de substâncias perigosas. Para proteger a saúde humana e o meio ambiente verifique a sua autoridade local para reciclagem conselho e instalações, somente na Europa.

Como inserir e remover as pilhas

Usar uma chave de fenda principal pequena de Phillips para afrouxar o parafuso e para remover a tampa de bateria. Introduzir 2 AA (ou LR6) baterias** frescas no compartimento de bateria com a polaridade correta (+/-). ** Não estão incluídas

(NL) Batterijgegevens

OPGEPAST: Om batterijgegevens te vermijden

- Verzeker je ervan dat de batterijen er op de juiste manier in te steken en volg steeds de aanduidingen van de speelgoed- en batterijfabrikanten.
- Meng geen oude en nieuwe batterijen of alkalische, gewone (koolstof-zink) of herlaadbare (nikkel-cadmium) batterijen met mekaar. Uitsluitend batterijen van dezelfde of van een aanbevolen equivalente soort dienen gebruikt te worden.
- Verwijder steeds uitgeputte of ontladen batterijen uit het product; veroorzaakt geen kortsluiting van de voedingspolen.
- Steek de batterijen erin volgens de juiste polariteit (+/-) zoals afgebeeld.

Belangrijke tips

- Alkalische batterijen worden aanbevolen.
- Herlaadbare batterijen worden niet aanbevolen.
- Verwijder herlaadbare batterijen uit het speelgoed alvorens ze te herladen; ze moeten slechts herladen worden onder het toezicht van een volwassene.
- Niet-herlaadbare batterijen mogen niet herladen worden.
- Bescherm onderdelen tegen stof; dompel ze niet of gebruik ze niet in water.
- Werp de batterijen niet in het vuur; ze zouden kunnen lekken of ontploffen en verwondingen veroorzaken.
- Verwijder alle batterijen wanneer het speelgoed gedurende lange tijd niet gebruikt zal worden.

 Het pictogram van een verwijdbare vuilnisbak geeft weer dat dit product niet samen met het gewone huis-, tuin- en keukenafval mag worden weggegooid, omdat het gevaarlijke substanties bevat. Bescherm gezondheid en milieu en vraag advies aan de plaatselijke afvalverwerkingsdienst over hoe en waar u producten kunt recyclen, alleen Europa.

Insteken en verwijderen van batterijen

Gebruik een kleine hoofdschroevendraaier Phillips om de schroef los te maken en de batterijdekking te verwijderen. Neem 2 verse AA (of LR6) batterijen** in het batterijcompartiment met op de correcte polariteit (+/-). ** Niet inbegrepen

Meet Emily & Audrey

Rencontrez Emily et Audrey

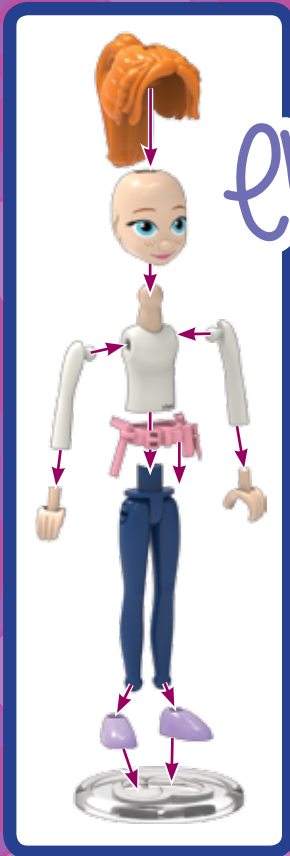

emily



Emily's favorite things!
Choses préférées de Emily !

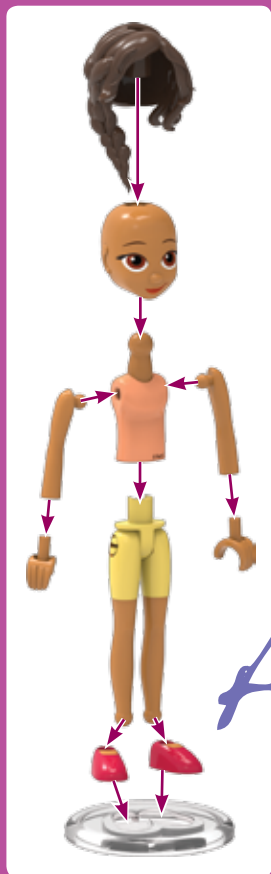

Audrey



Audrey's favorite things!
Choses préférées de Audrey !



We like to design new inventions in our clubhouse! Can you help us build our latest ideas?

Nous aimons concevoir de nouvelles inventions dans notre club! Pouvez-vous nous aider à construire nos idées les plus récentes ?

inventor's CLUBHOUSE

CLUBHOUSE

de l'inventeur



1

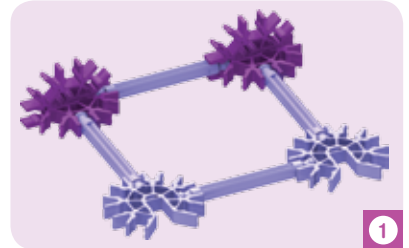
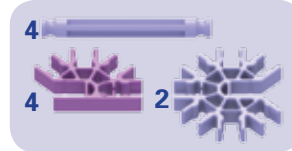
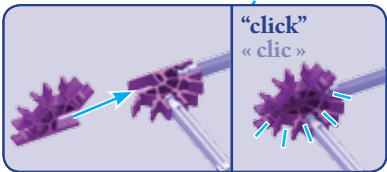
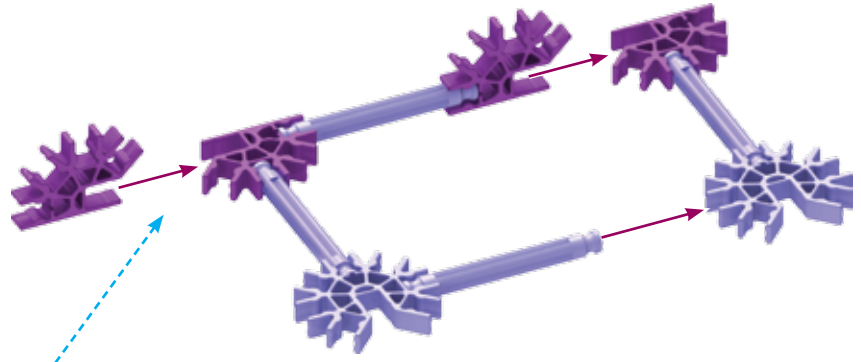

2

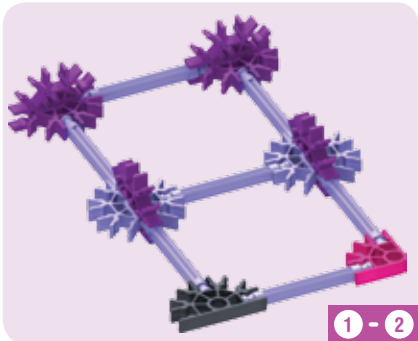
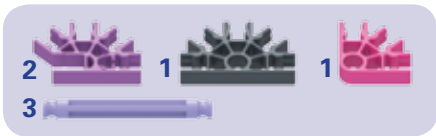
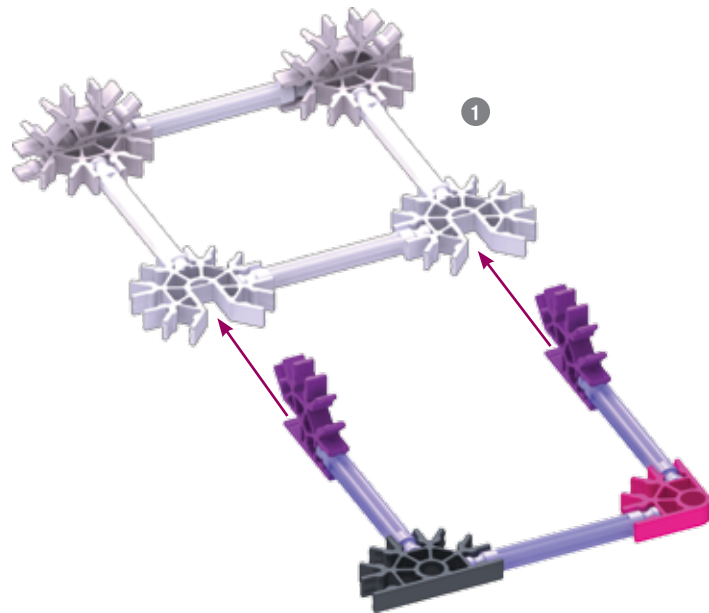

3

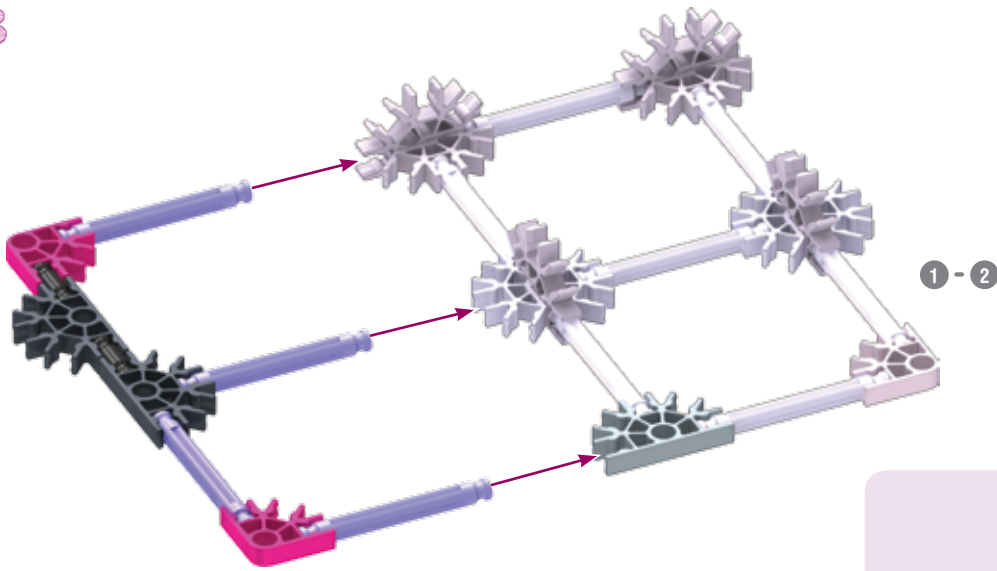

1 - 2

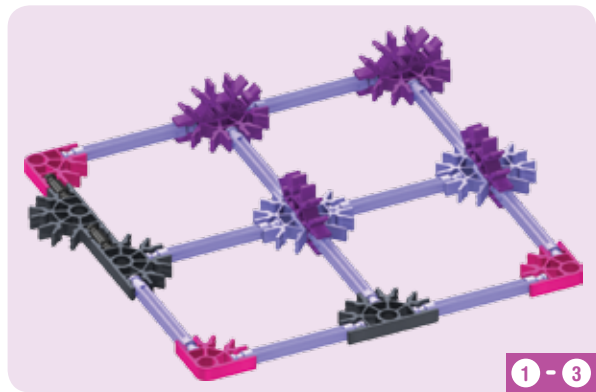
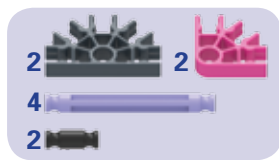

1 - 3

4

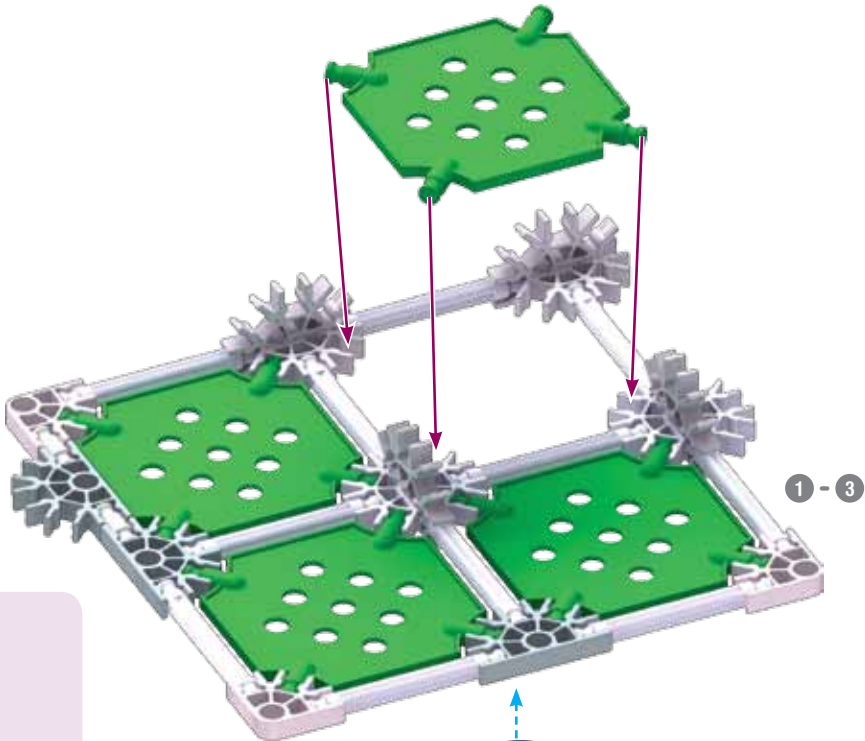

1 - 3

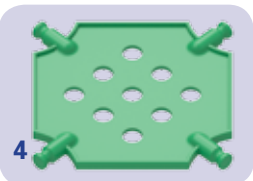

4

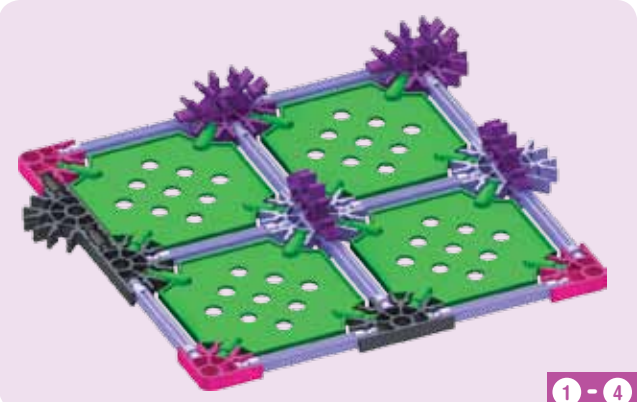

1 - 4

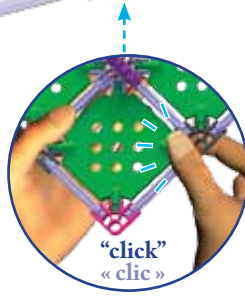

5

2  5  5 

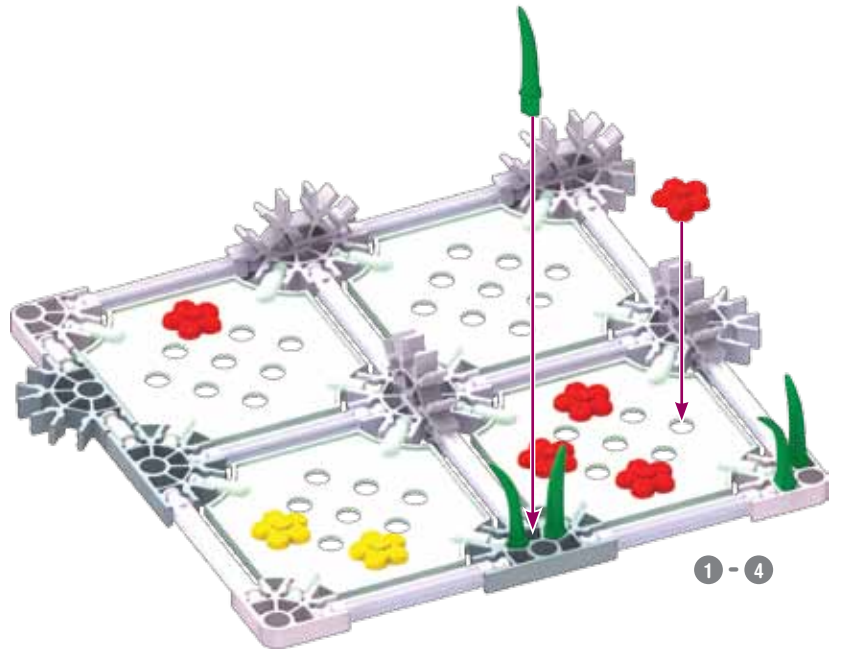
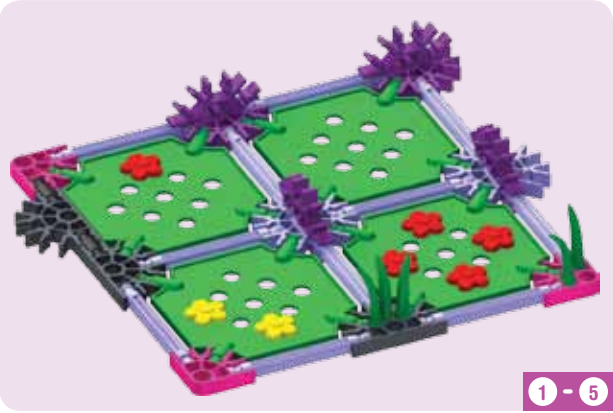

6

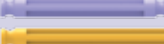
1  1 
 2 
 1 
 3 

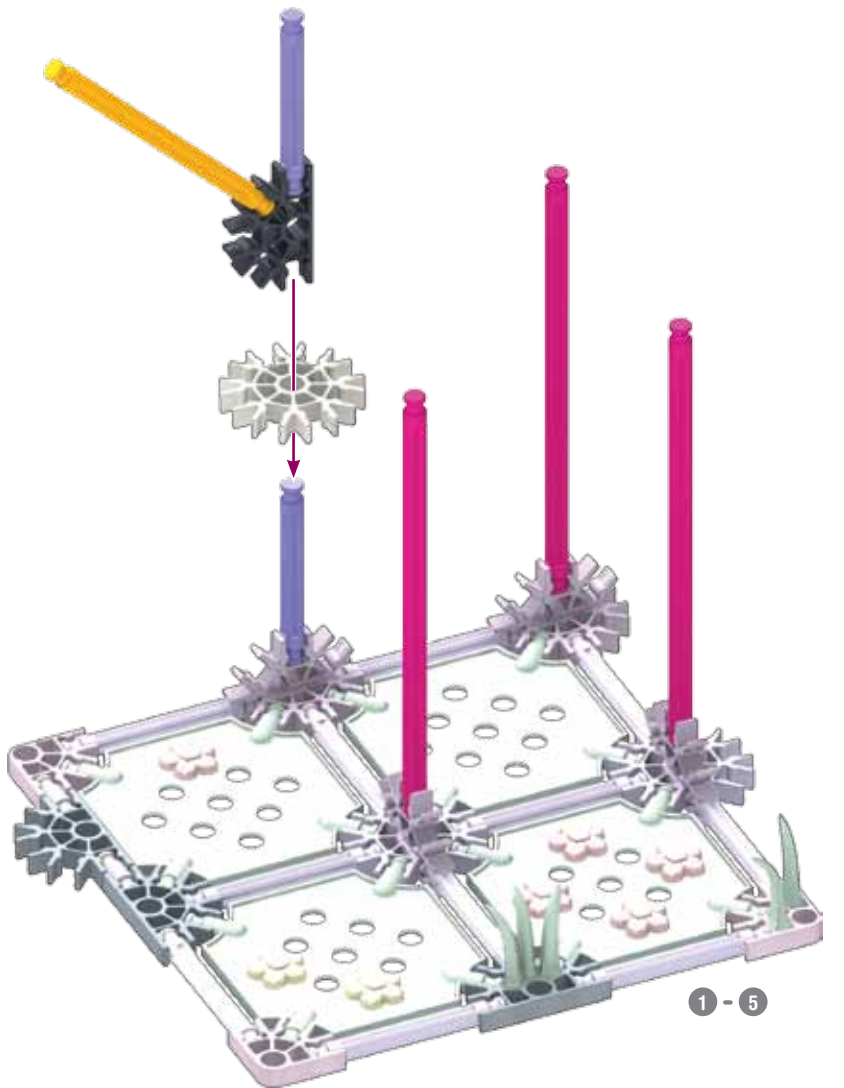
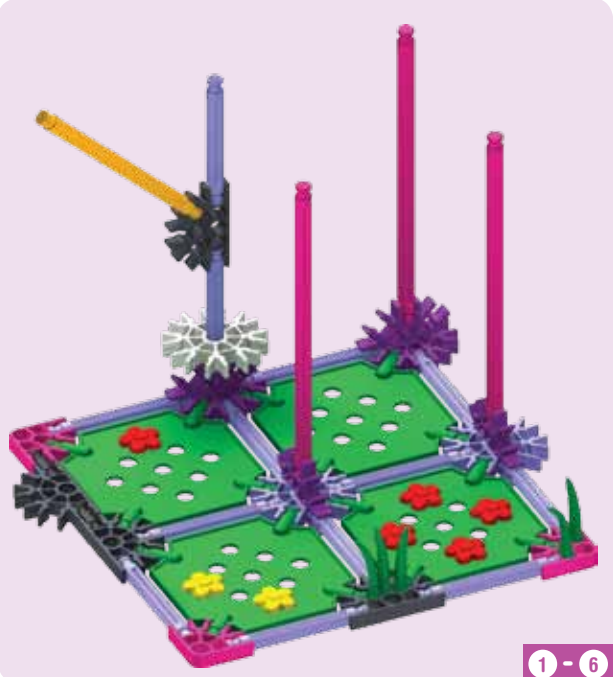

7

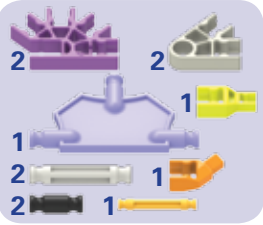
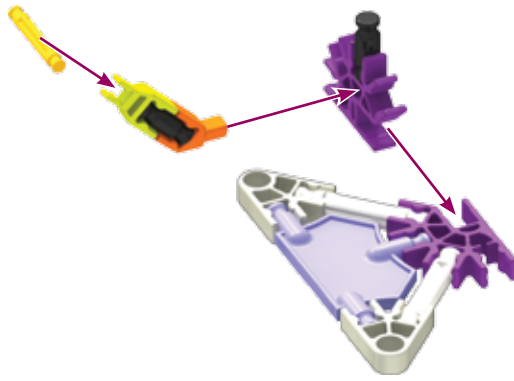

7

8

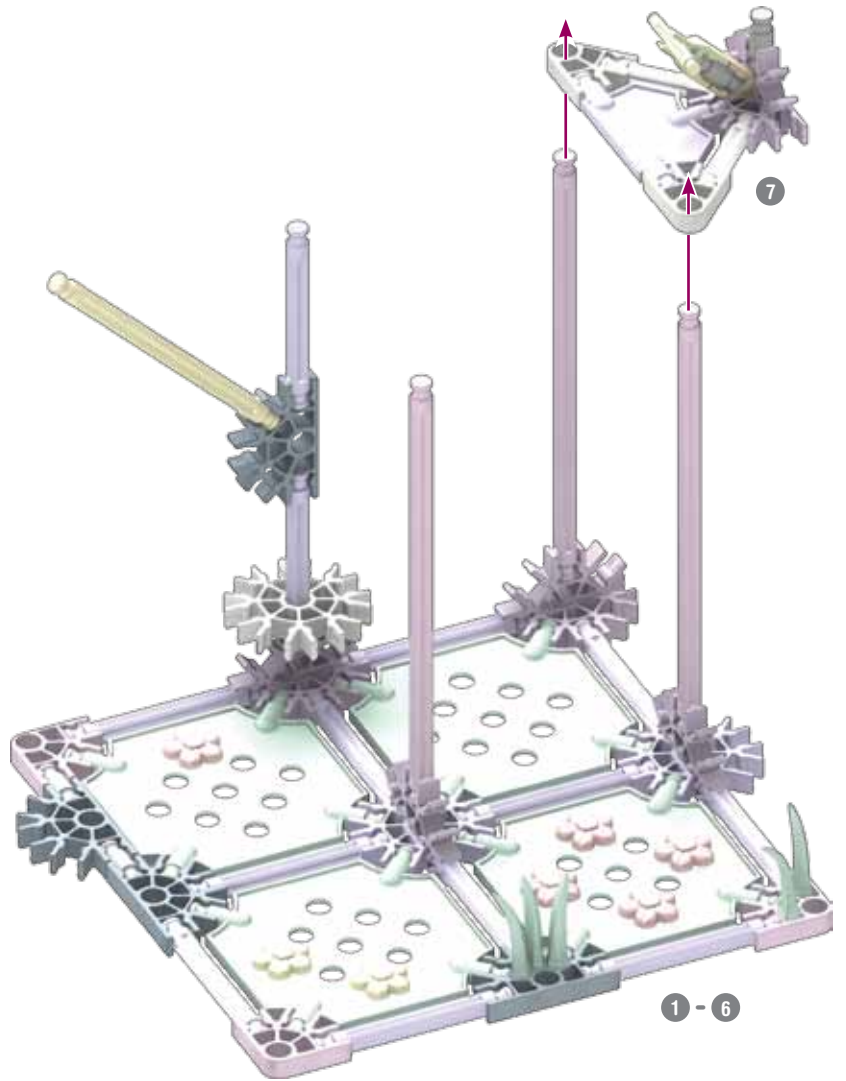

1 - 6

1 - 8

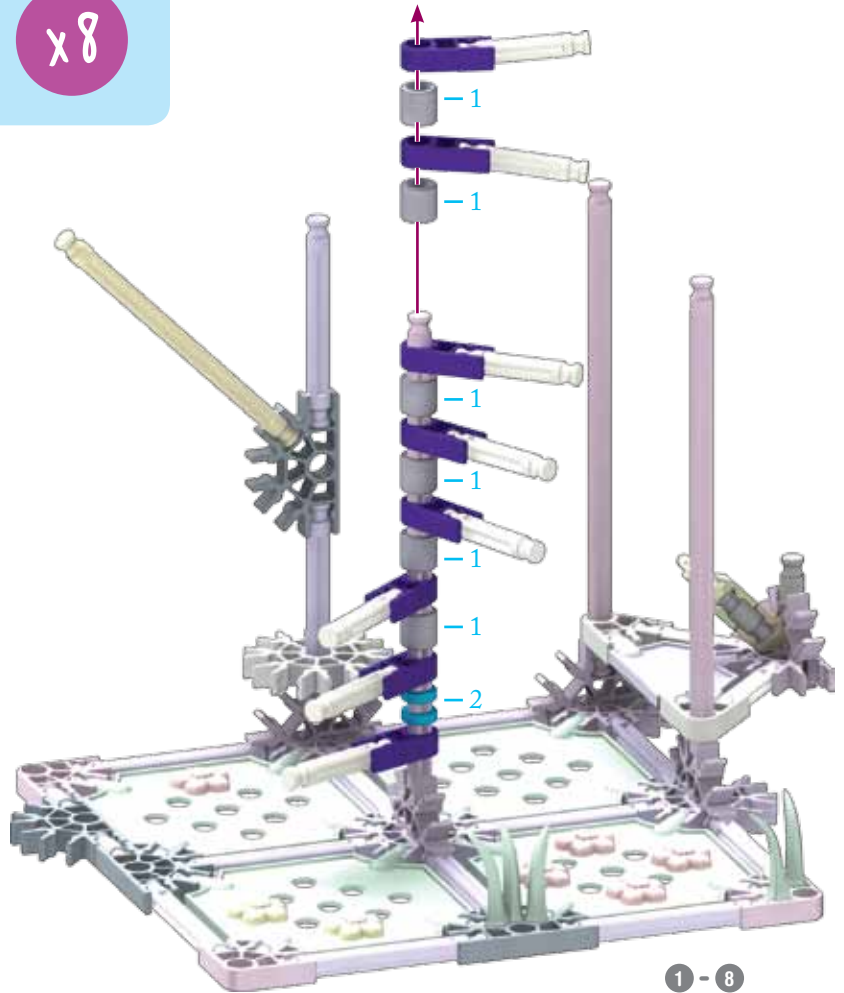

- 8 6 2
- 8

1 - 8



1 - 9

10

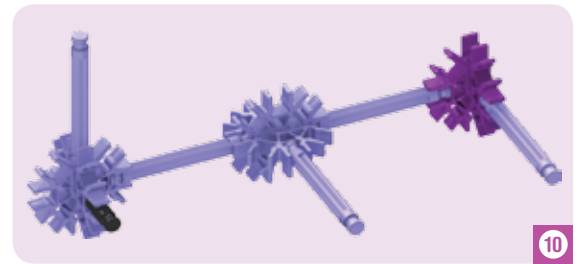
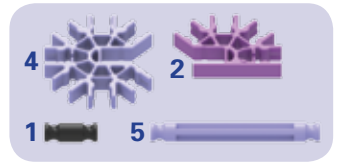
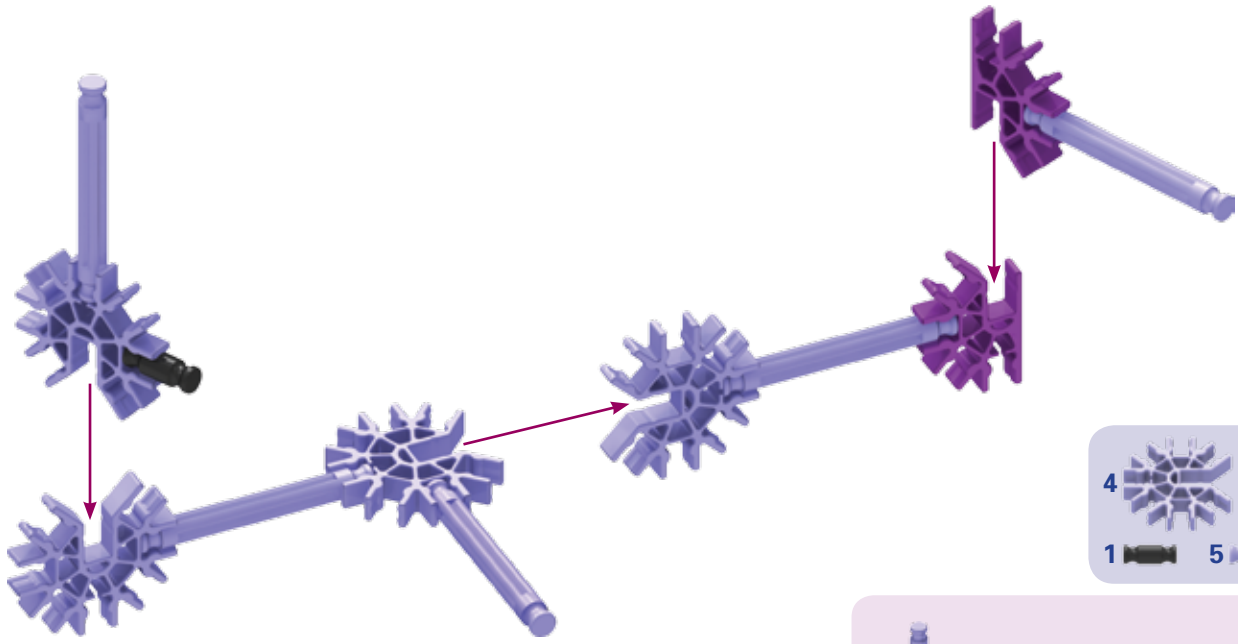

11

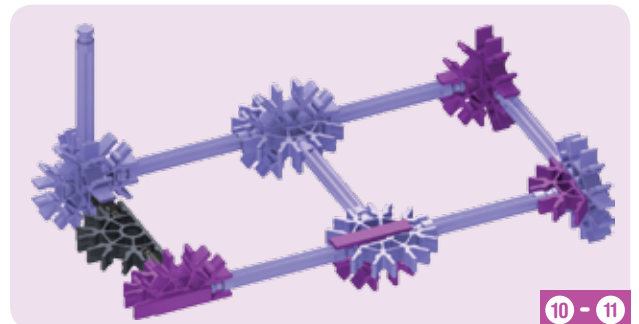
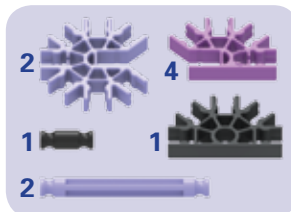
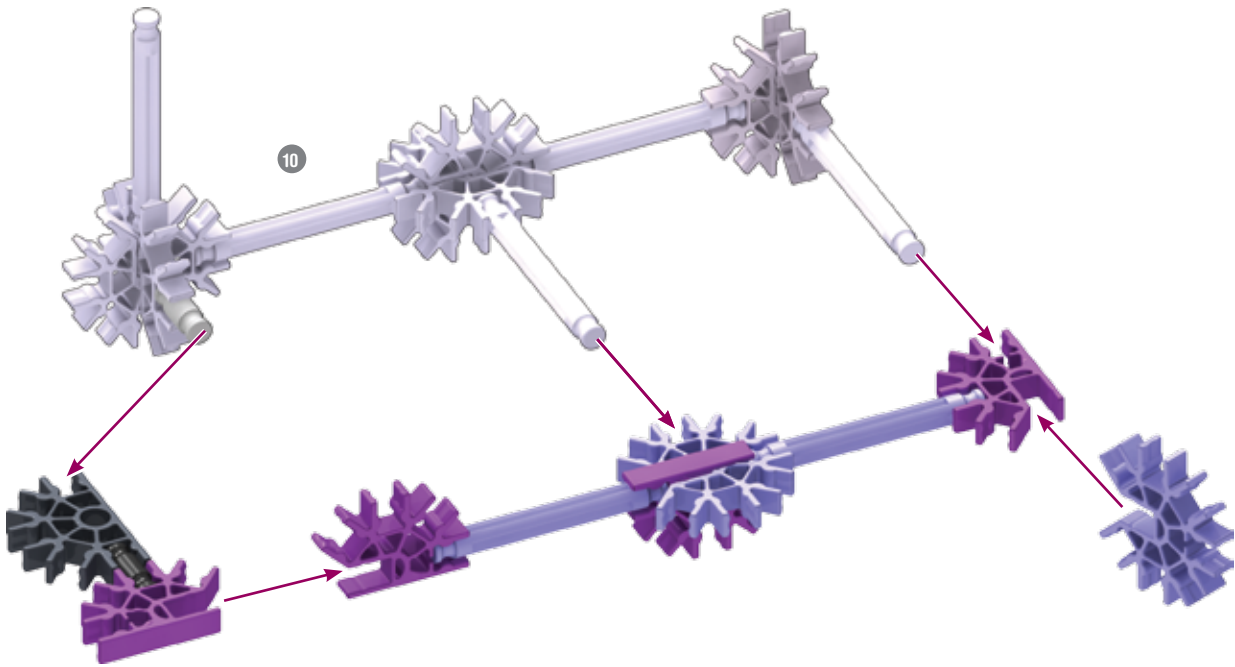

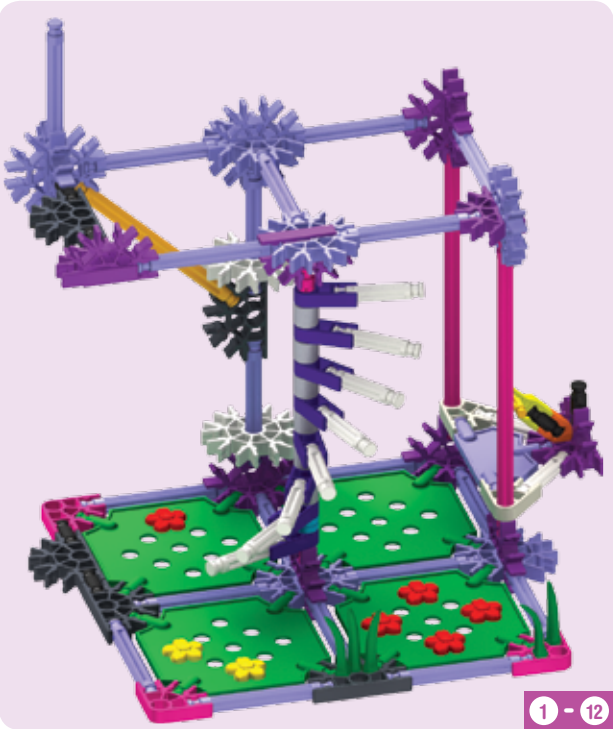
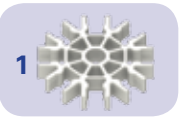
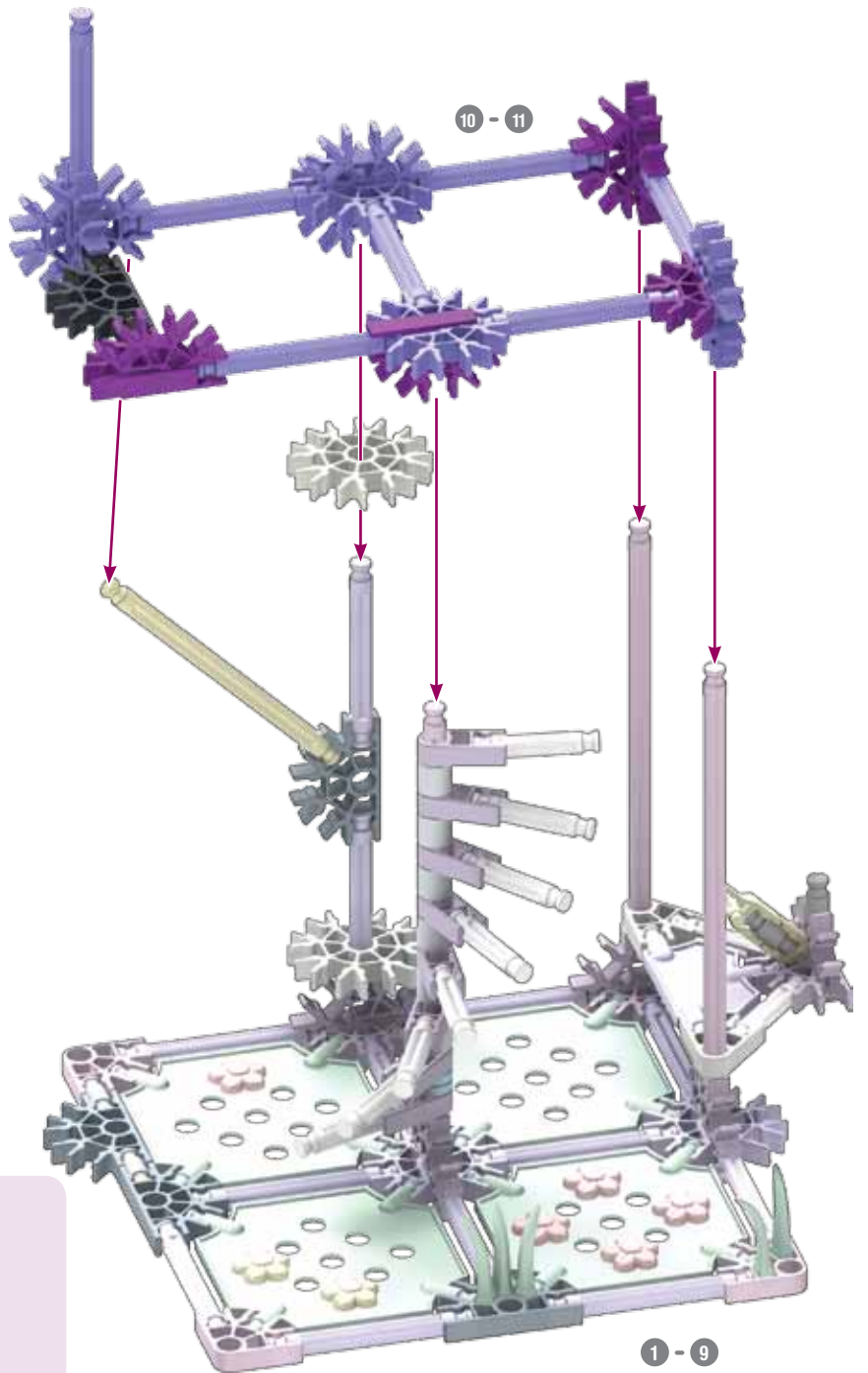

1 - 12

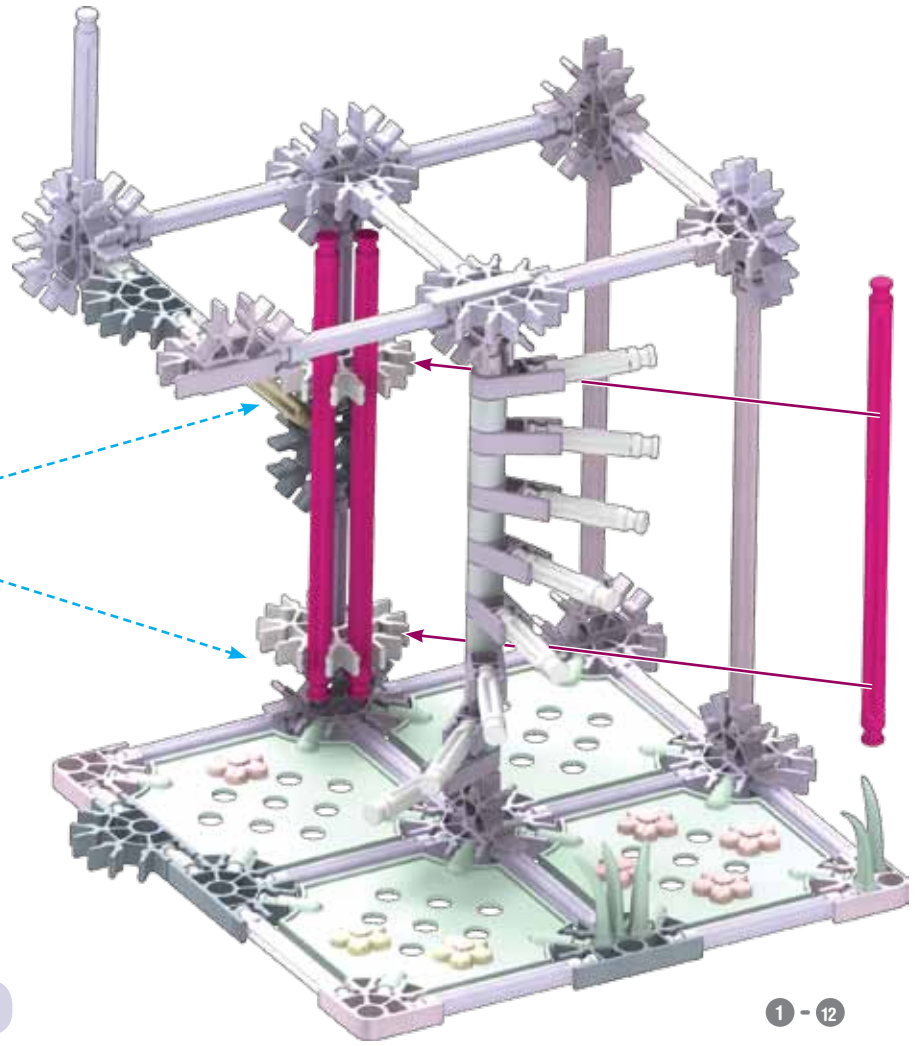
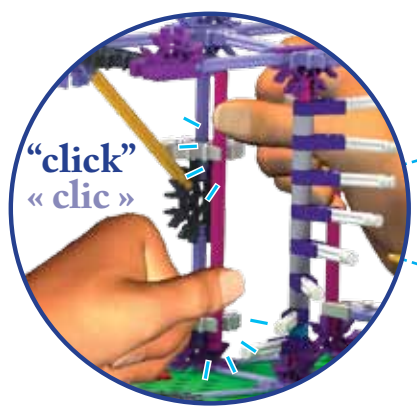

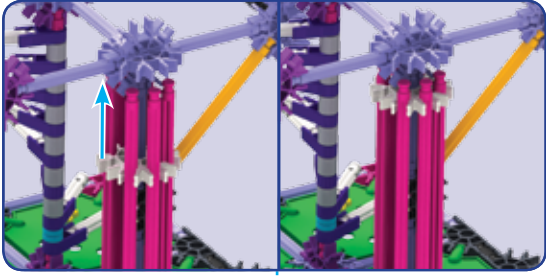

rotate model
pivoter le modèle

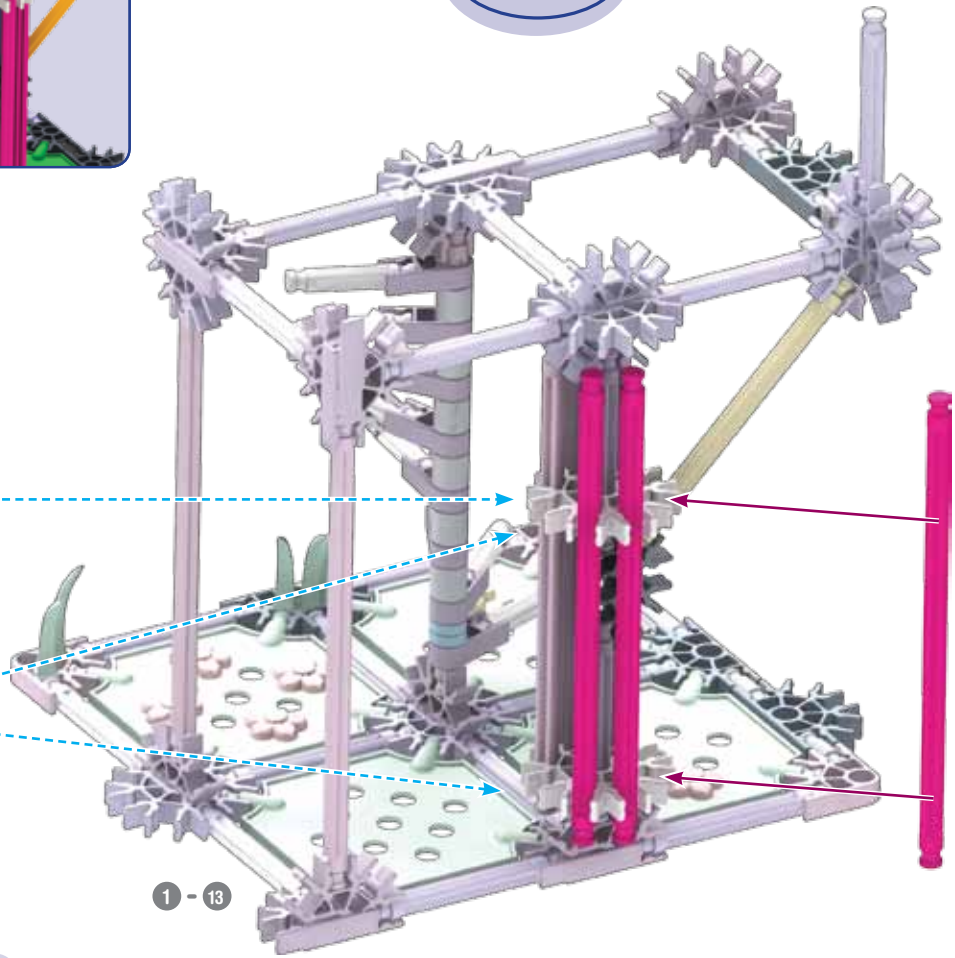
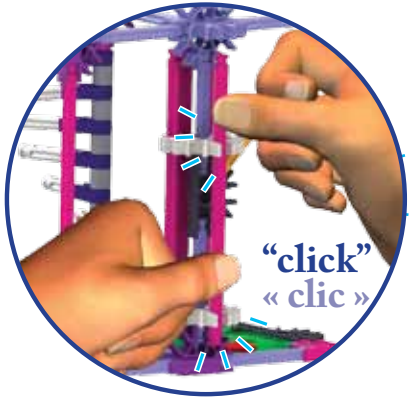

1 - 13



1 - 14

rotate model
pivoter le modèle

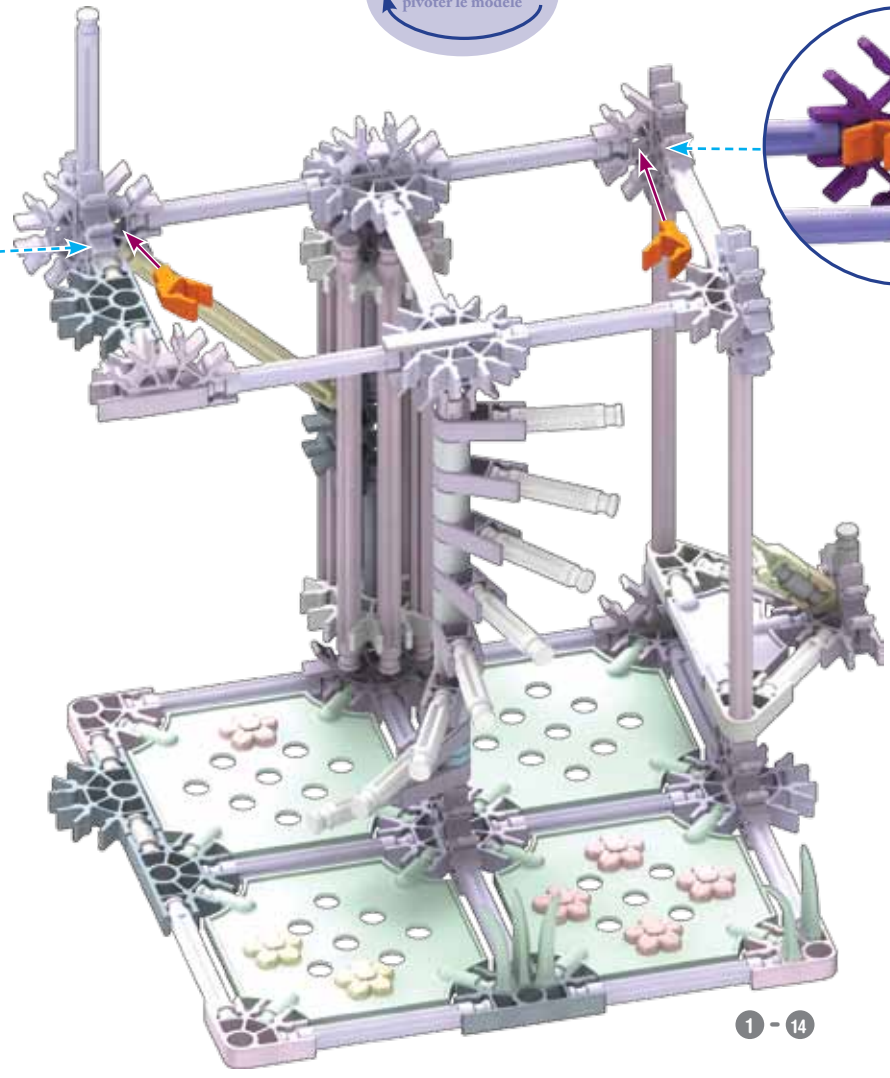

1 - 14

2

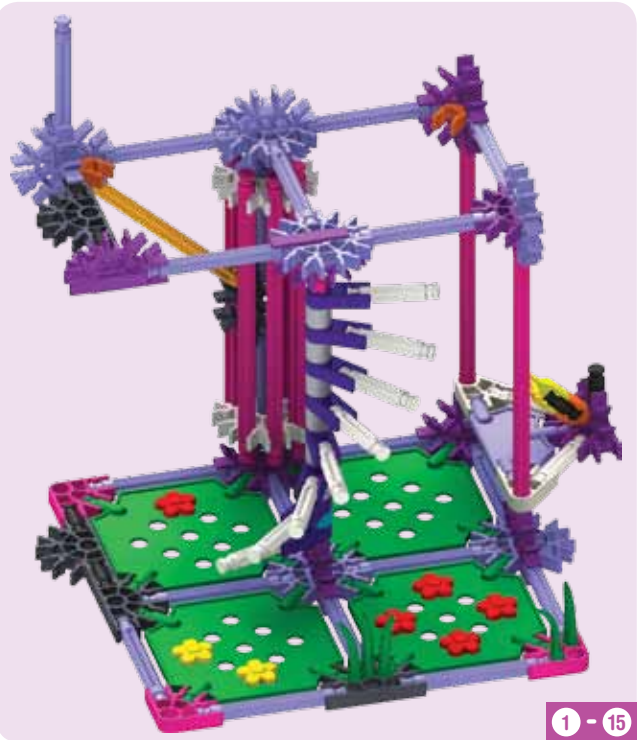

1 - 15

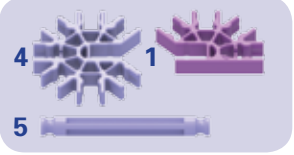
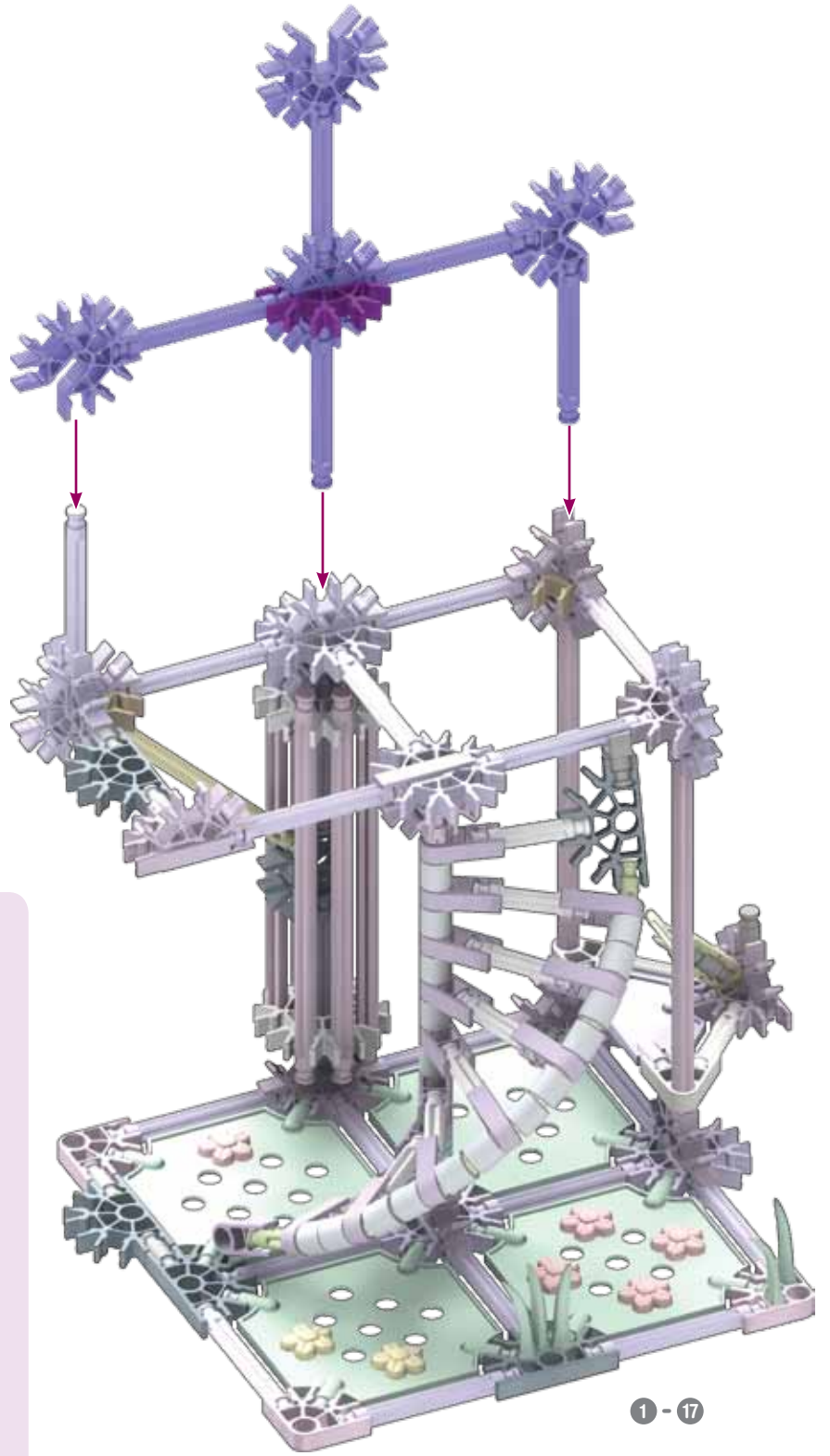

19

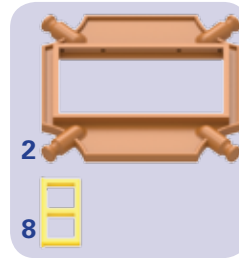
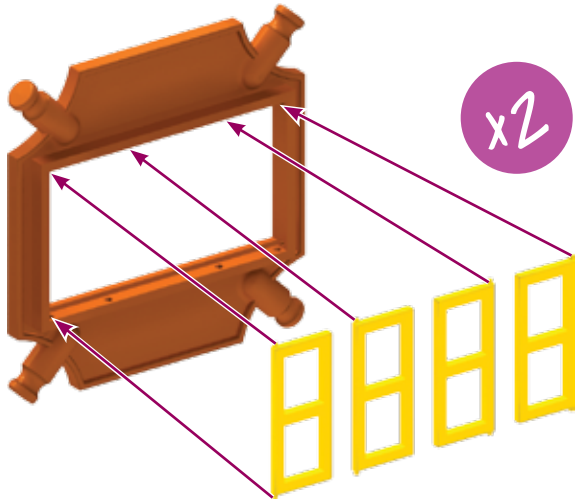

20

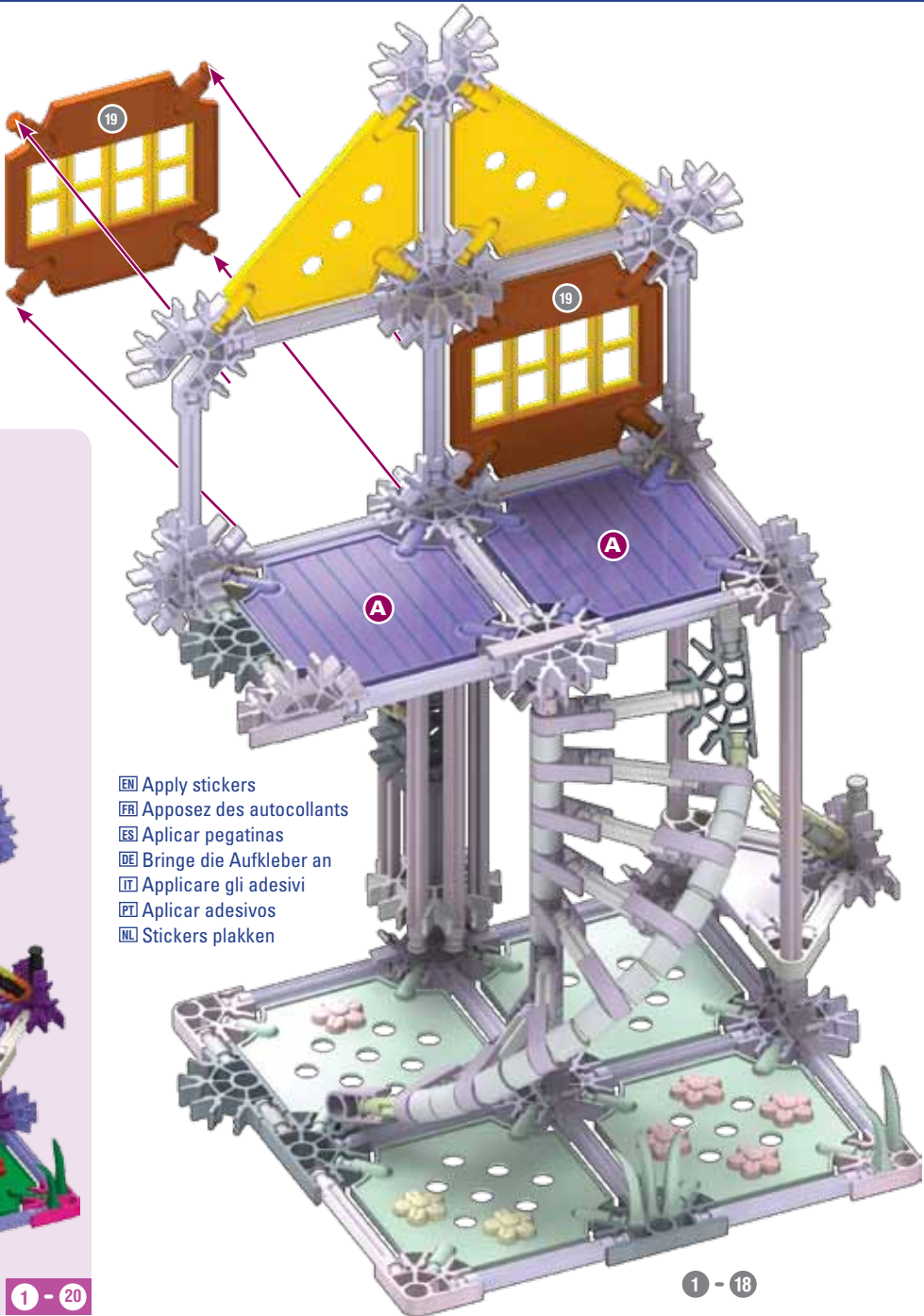
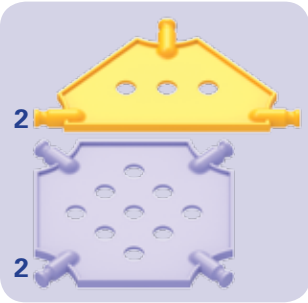

- EN Apply stickers
- FR Appelez des autocollants
- ES Aplicar pegatinas
- DE Bringe die Aufkleber an
- IT Applicare gli adesivi
- PT Aplicar adesivos
- NL Stickers plakken

1 - 20

1 - 18





rotate model
pivoter le modèle

1 - 21

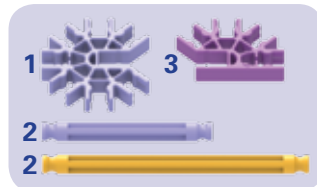

1 - 22

rotate model
pivoter le modèle

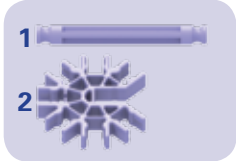
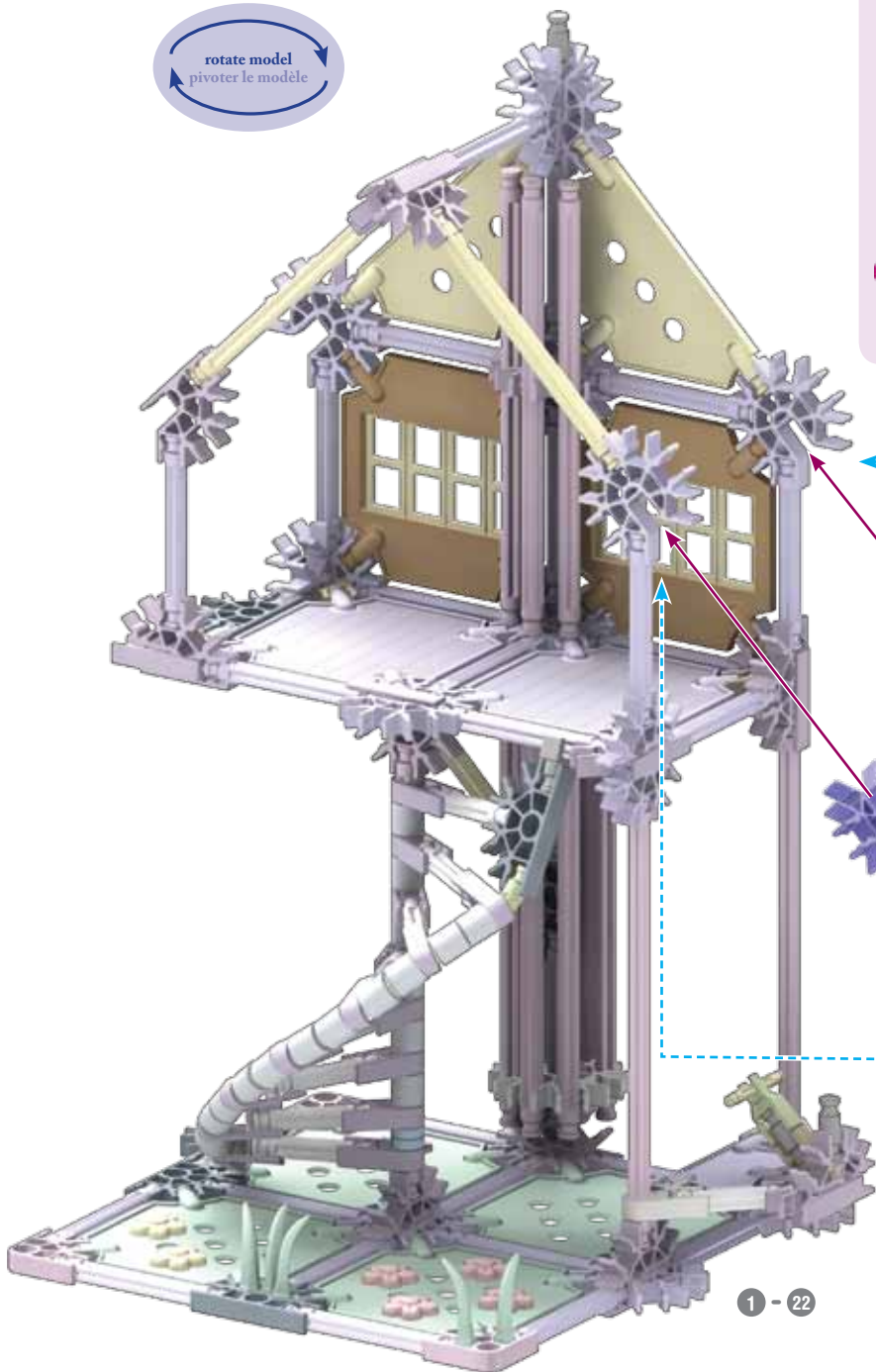

24

- Apply sticker
- Appelez des autocollant
- Aplicar pegatina
- Bringe die Aufkleber an
- Applicare gli adesivi
- Aplicar adesivo
- Sticker plakken

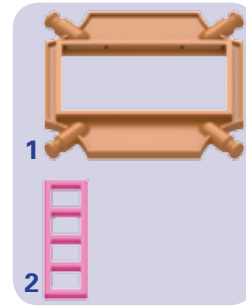
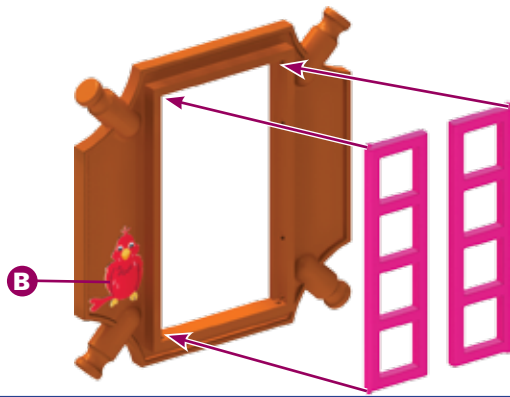

24

25

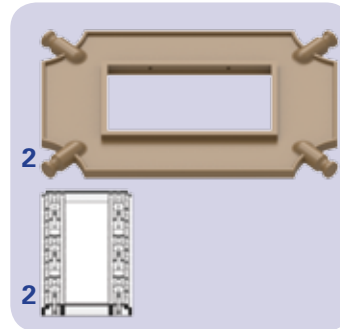
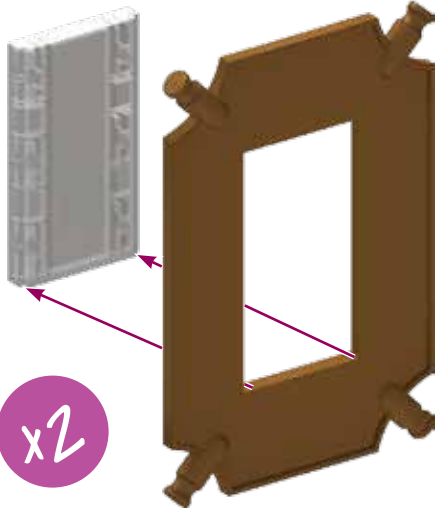

25

26

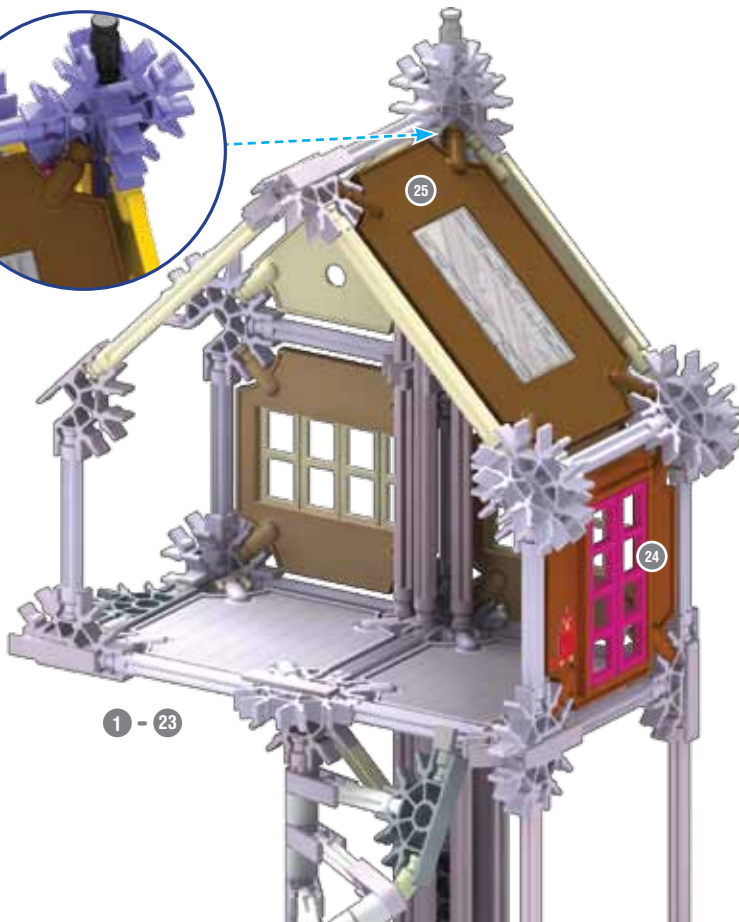
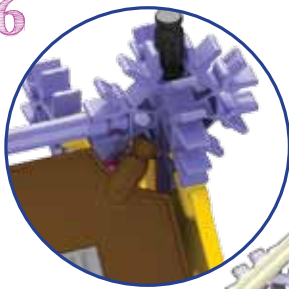

1 - 26

rotate model
pivoter le modèle

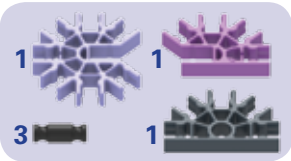

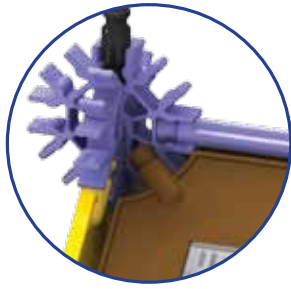

1 - 27



1 - 28



x2



x2

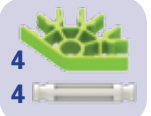



30

29

29

1 - 28



1 - 31



2

32

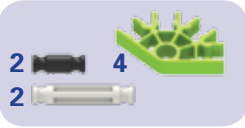

x2

33



x3



34



1 - 31

1 - 34

35



x2

36



37



rotate model
pivoter le modèle

1 - 34



1 - 37

38



x4

8



8

39



rotate model
pivoter le modèle

- 4 2
- 2 1
- 3 3
- 1 1
- 1 1



1 - 39

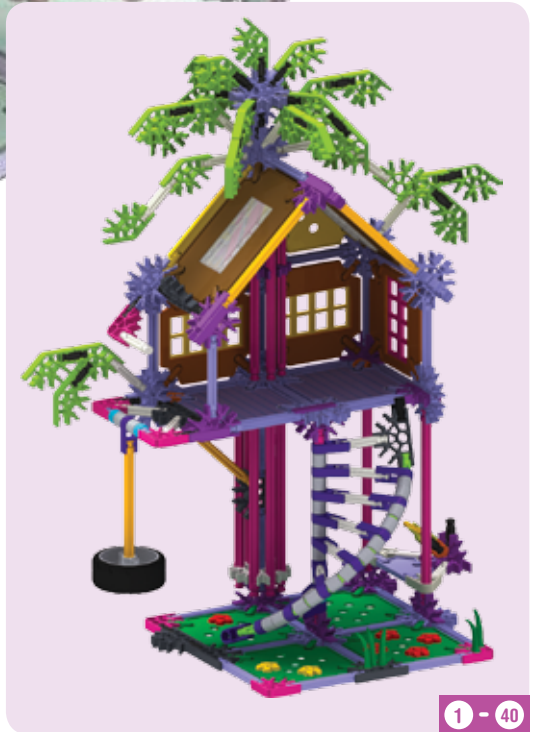

1 - 40

Great work building the clubhouse. Now, we can add on a tire swing!

Beau travail a consruire le clubhouse. Maintenant, nous pouvons ajouter sur un pneu balançoire !





1 - 40

Let's add an elevator to the clubhouse. By using a pulley and lever, we can make it easier for the elevator to go up and down.

Ajoutons un ascenseur au clubhouse. À l'aide d'un levier et poulie, nous pouvons rendre la vie plus facile à l'ascenseur pour aller vers le haut et vers le bas.



- 3
- 1
- 1
- 1
- 1
- 3
- 2
- 2

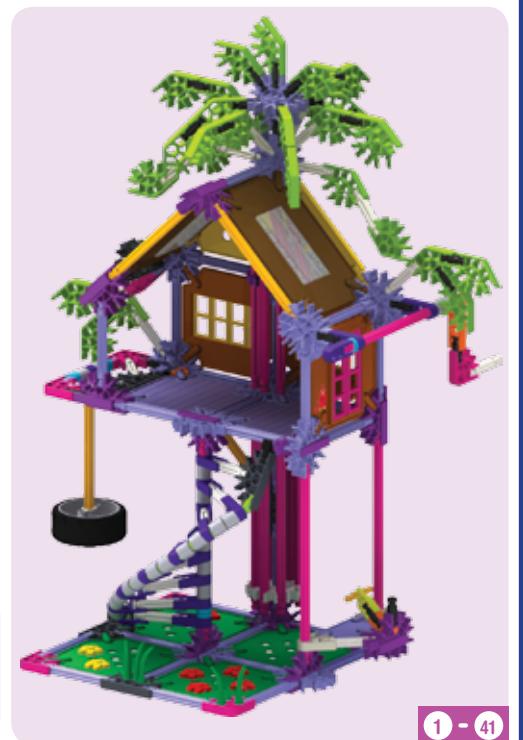

1 - 41

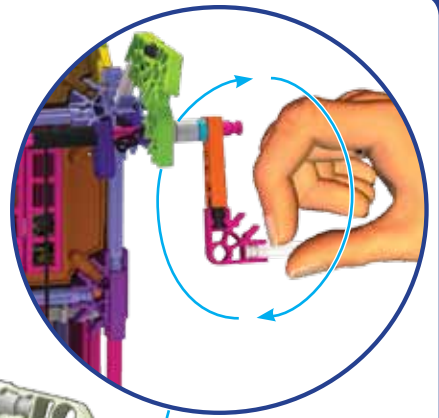

1 - 41



2

1



1 - 42

We should also add a zipline to the clubhouse. Did you know that when you zip down the line, your stored, or potential energy, is turned into kinetic energy? Kinetic energy is the energy of motion.

Nous devrions également ajouter une tyrolienne au clubhouse. Saviez-vous que lorsque vous descendez en tyrolienne, votre réserve d'énergie est convertie en énergie cinétique ? L'énergie cinétique est l'énergie du mouvement.



- 2
- 1
- 7
- 2
- 3
- 4



- 1
- 2
- 2
- 2
- 1

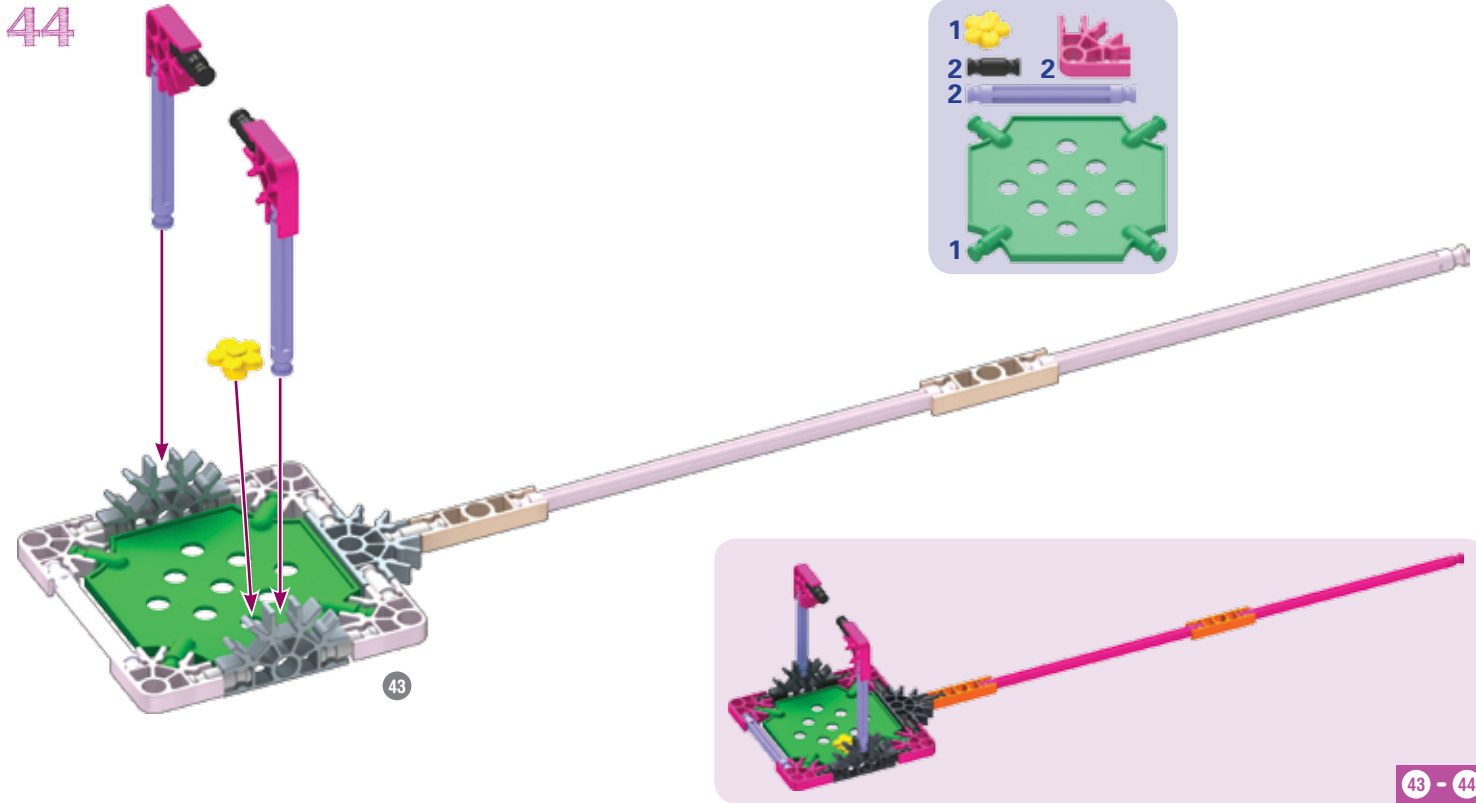



1 - 45



1 - 42

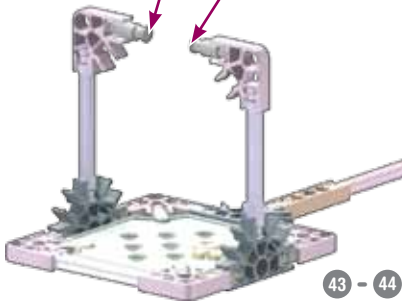

43 - 44

- 1
- 1
- 1
- 1
- 1

1

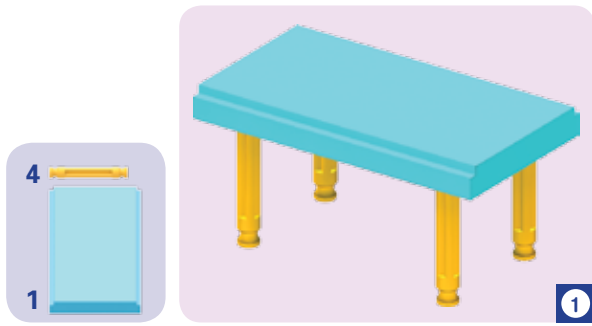
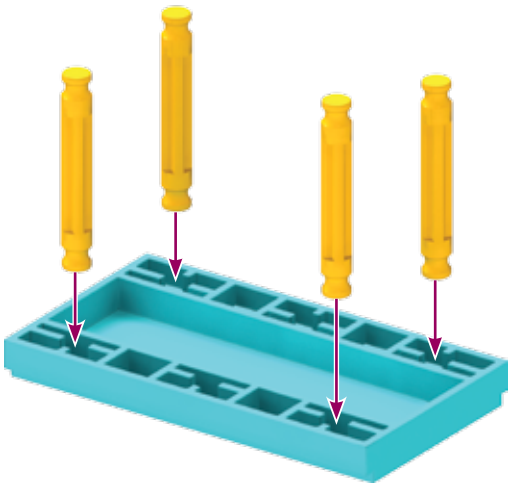

2

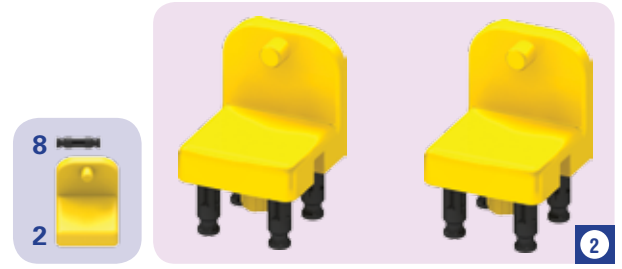
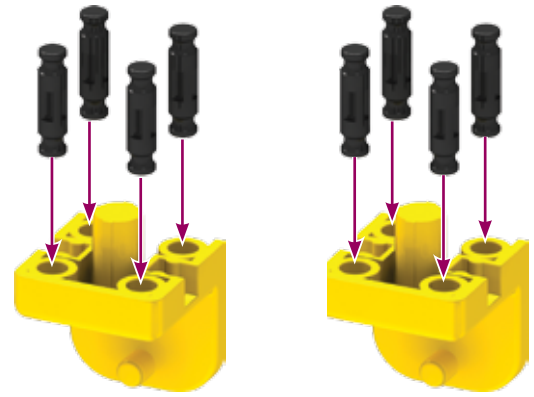

3

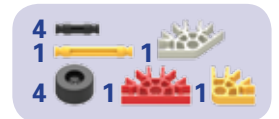
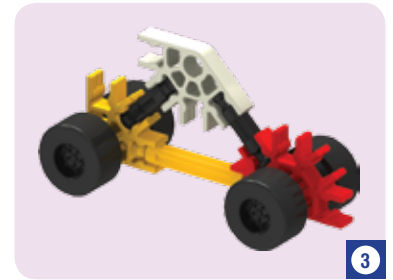
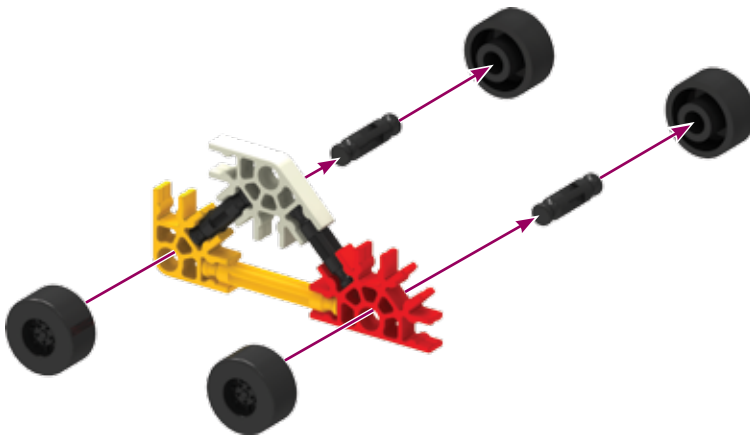

4

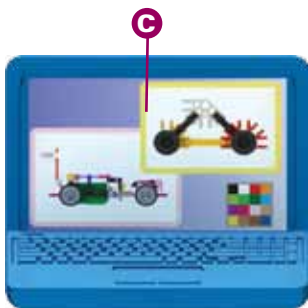

- Apply sticker
- Appliquez des autocollants
- Aplicar pegatina
- Bringe die Aufkleber an
- Applicare gli adesivi
- Aplicar adesivo
- Sticker plakken

Creating this model car gave me a fantastic idea! Can you help me build a car that Audrey and I can drive?

En créant cette modèle de voiture sa m'a donné une idée fantastique ! Pouvez-vous m'aider à construire une voiture qu' Audrey et moi peut conduire ?







1

- EN Did you install 2 AA (or LR6) batteries in the motor?
- FR Est-ce que tu as installé 2 piles AA (ou LR6) dans le moteur ?
- ES ¿Instalaste 2 pilas AA (o LR6) en el motor?
- DE Hast du 2 AA (oder LR6) Batterien in den Motor eingelegt?
- IT Hai installato 2 batterie AA (o LR6) nel motore?
- PT Foram instaladas as pilhas 2 AA (ou LR6) no motor?
- NL Heb je 2 AA (of LR6)-batterijen in de motor geplaatst?

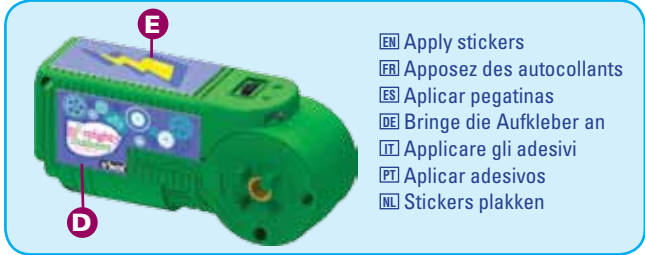
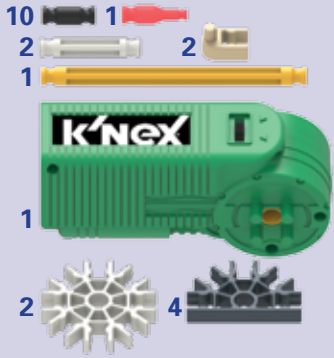
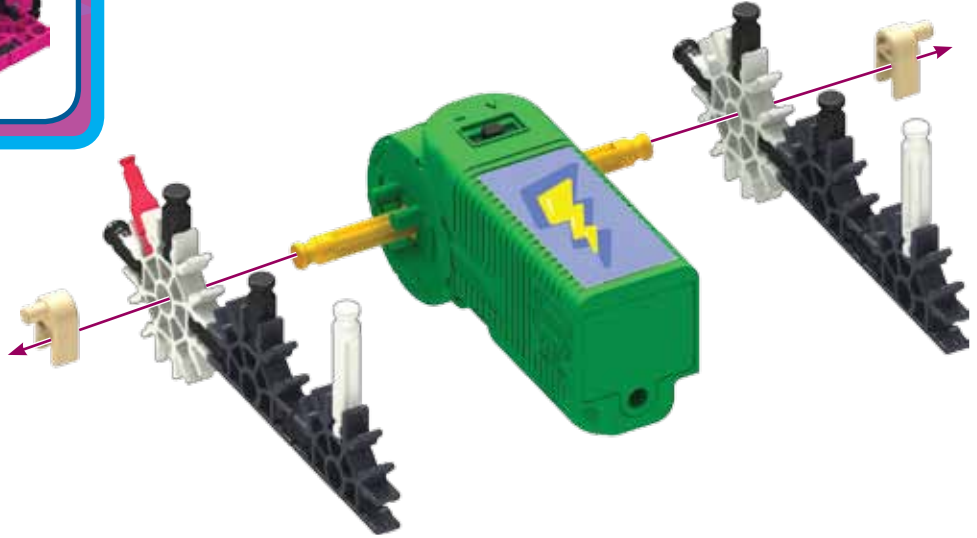
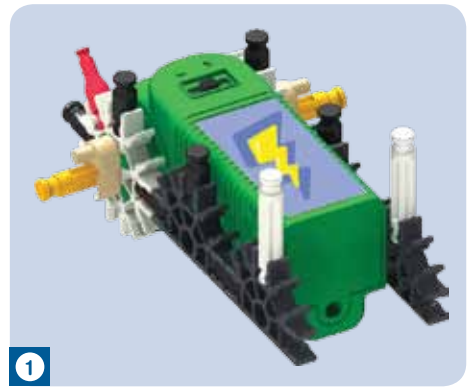

- EN Apply stickers
- FR Apposez des autocollants
- ES Aplicar pegatinas
- DE Bringe die Aufkleber an
- IT Applicare gli adesivi
- PT Aplicar adesivos
- NL Stickers plakken

2

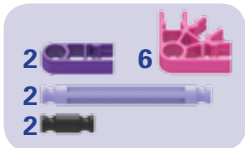
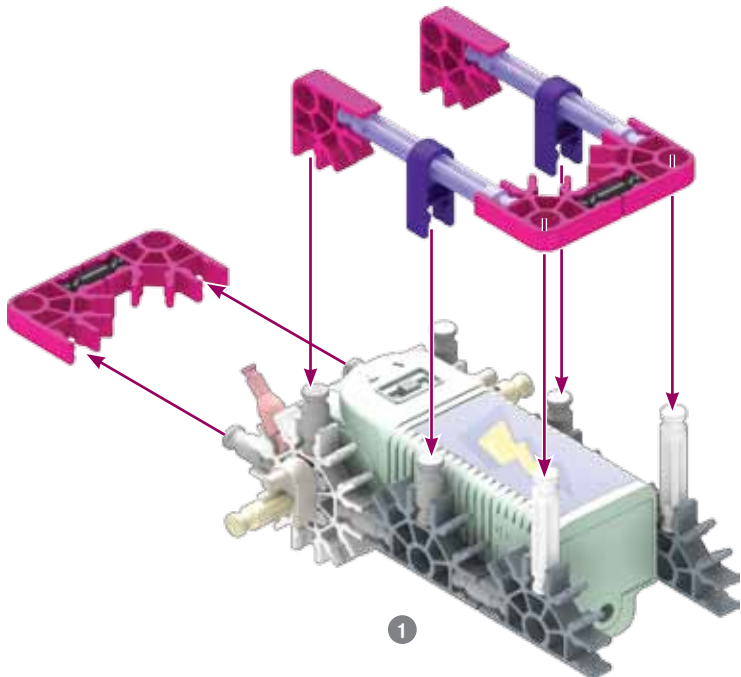

3

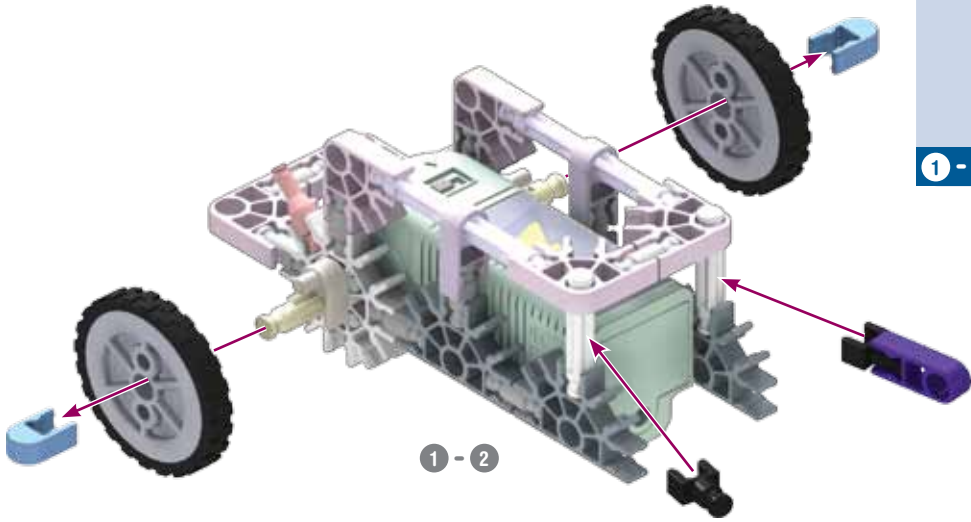

1-3



- 1
- 2
- 2
- 2
- 2

4

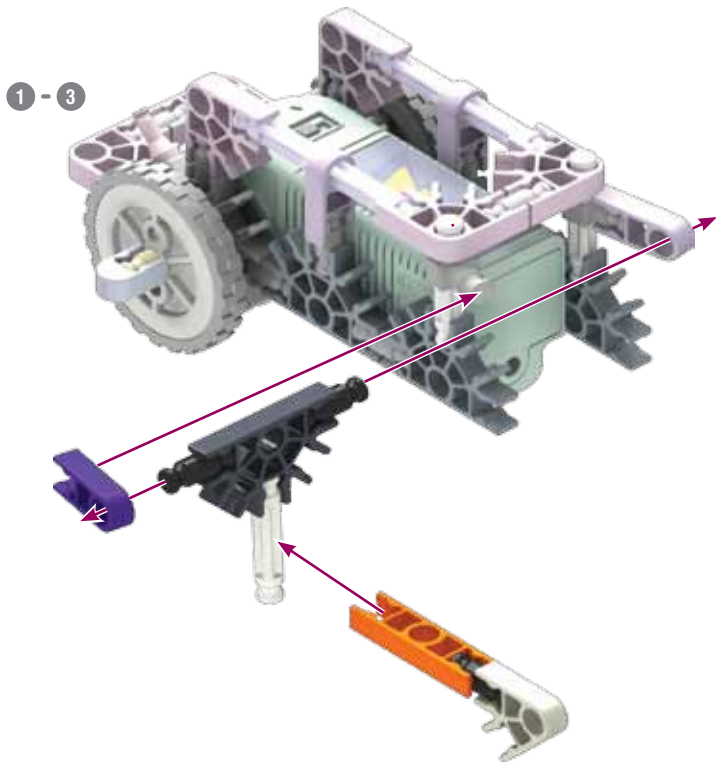

1-4

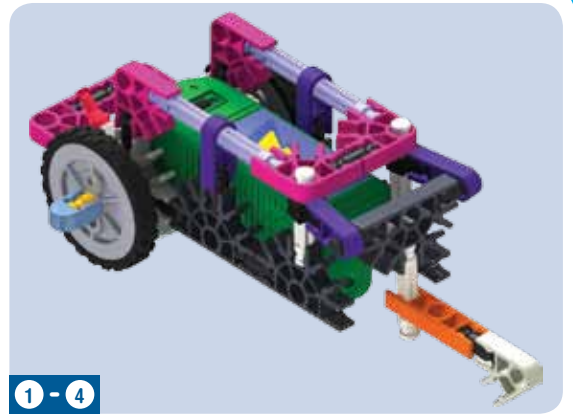

- 1
- 1
- 1
- 1
- 1
- 3

5

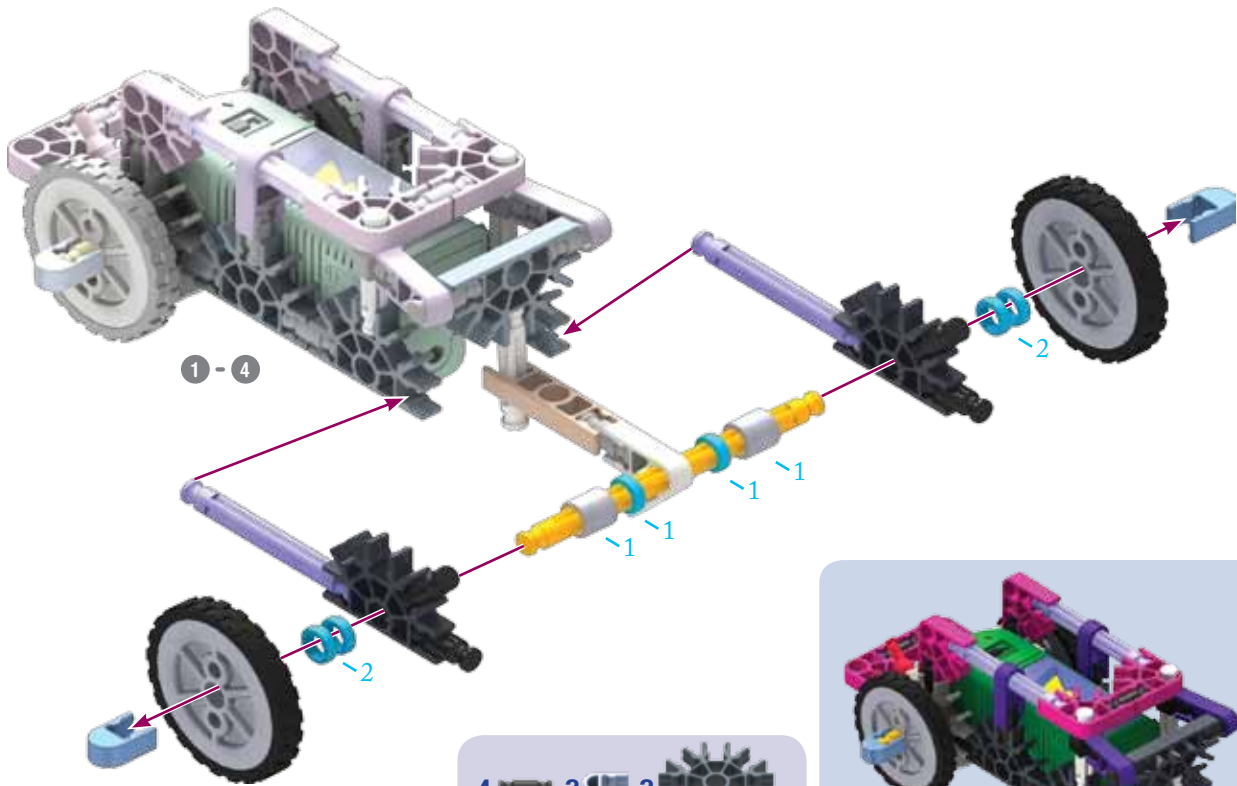

- 4 [Black Pin]
- 2 [Blue Pin]
- 2 [Black Gear]
- 2 [Purple Axle]
- 6 [Yellow Axle]
- 2 [Grey Axle]
- 1 [Yellow Axle]
- 2 [Black Wheel]
- 2 [Black Tire]



6

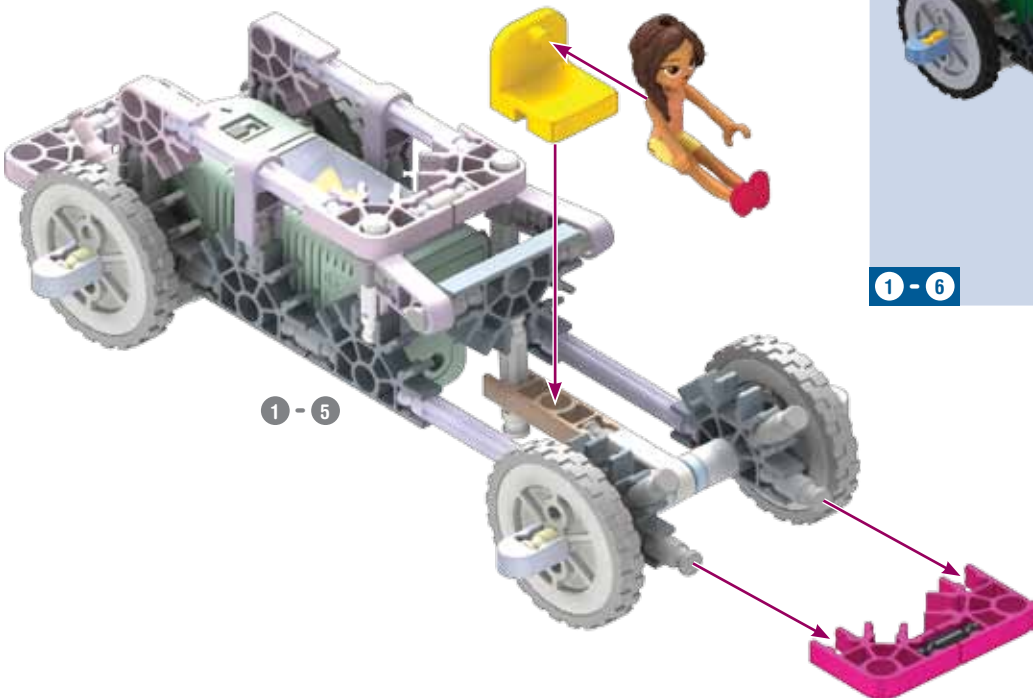

- 1 [Black Pin]
- 2 [Pink Base Plate]
- 1 [Yellow Seat]



We built the clubhouse!
Now grab your Mighty Makers®
card to get started on your first
invention.

Nous avons construit le clubhouse !
Maintenant prenez votre carte de
Mighty Makers® pour
commencer votre première
invention.



Alternate Models Modèles Alternatif

41

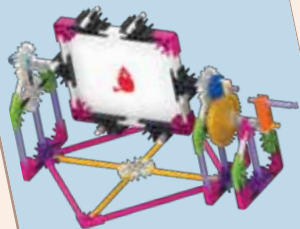

animation machine
machine d'animation

47



flapping bird
oiseau battant

55



eggbeater
bateur à œufs

59



optical illusion machine
machine à illusion d'optique

#IAmAMightyMaker

For instructions of these models go to www.knex.com/instructions and enter code 43753.

Pour les instructions de ces modèles vont à www.knex.com/instructions et entrez dans le code 43753.



fan
ventilateur



fishing pole
canne à pêche



flag pole
mât de drapeau



wheelbarrow
brouette

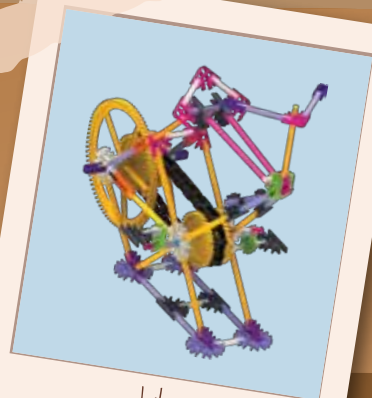

bike
vélo

Invention: Animation Machine
Invention : Machine d'animation

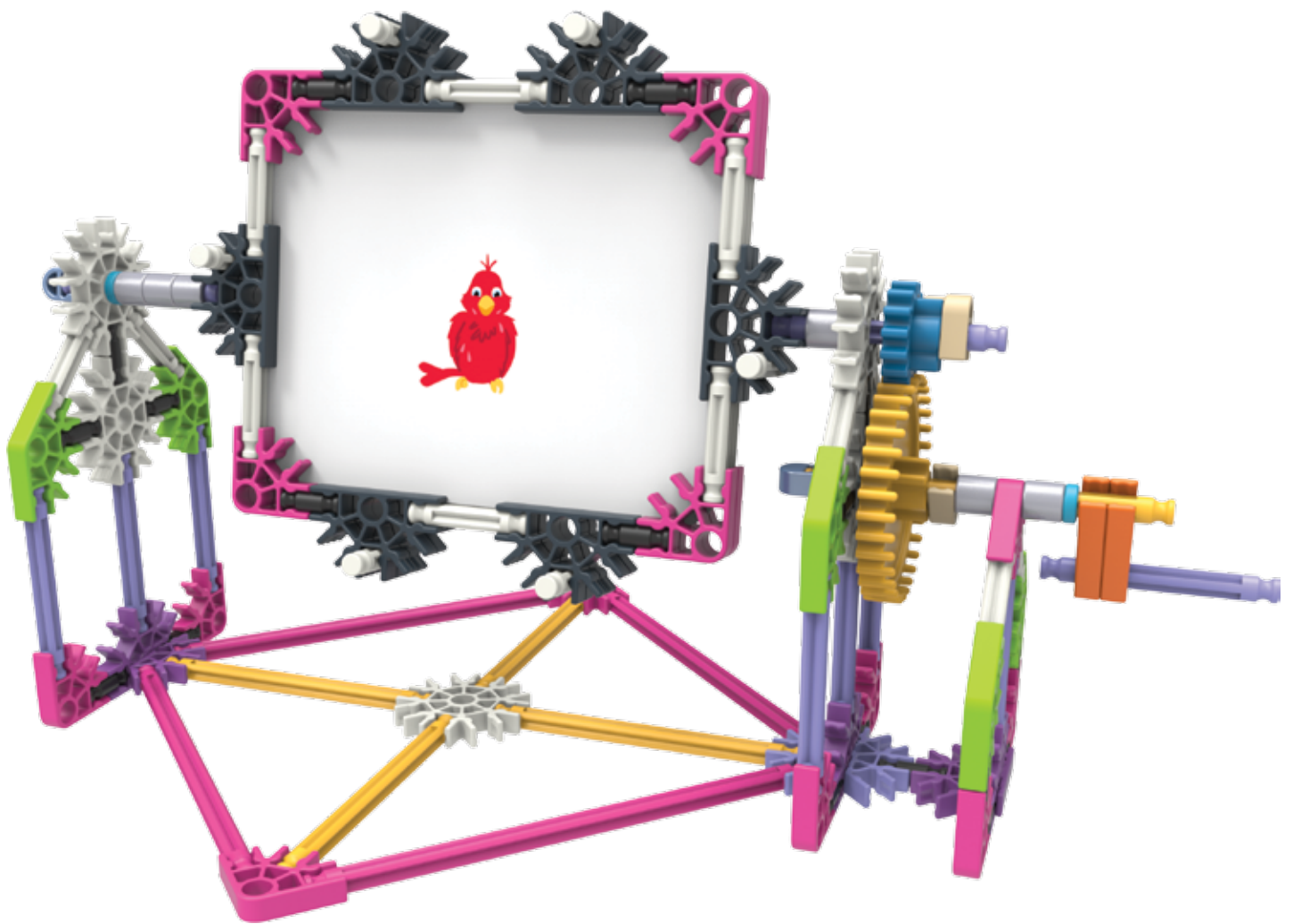

1

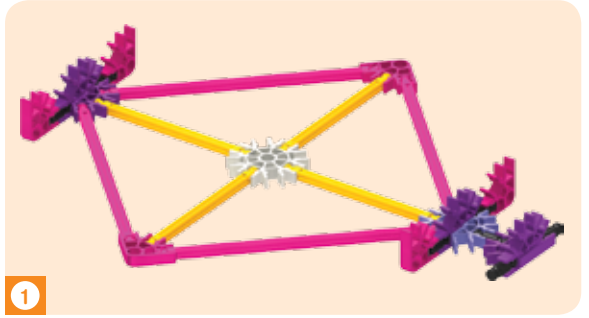

2

x4

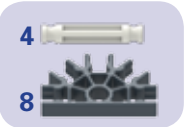
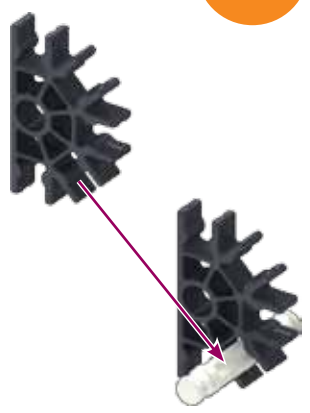

2

3

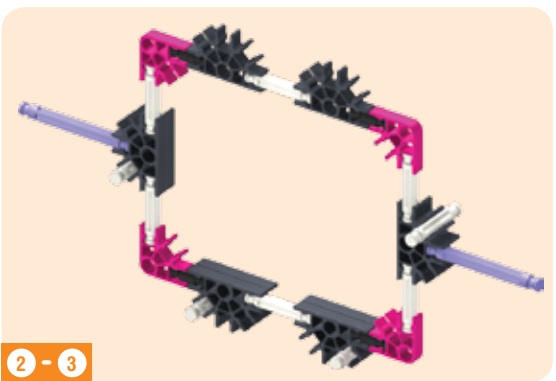
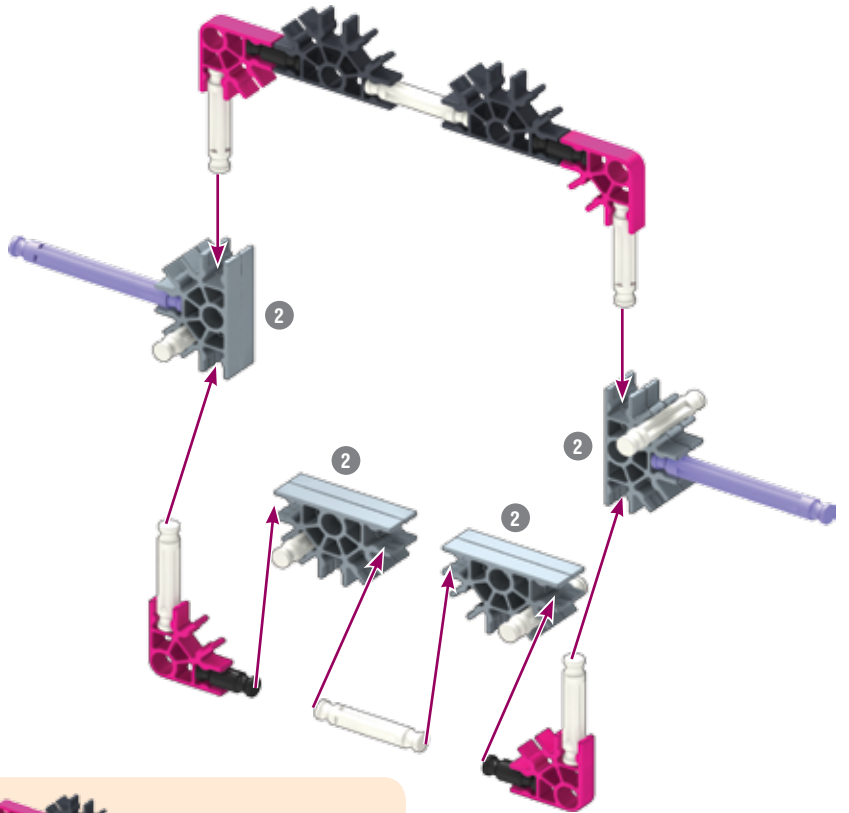

4

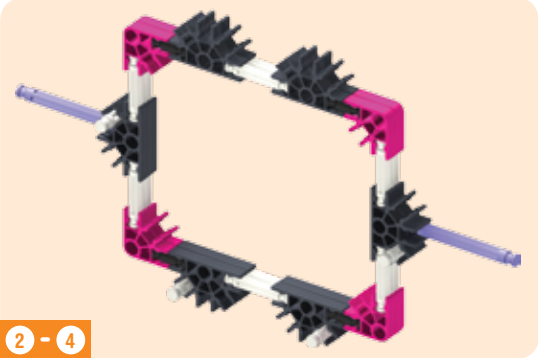
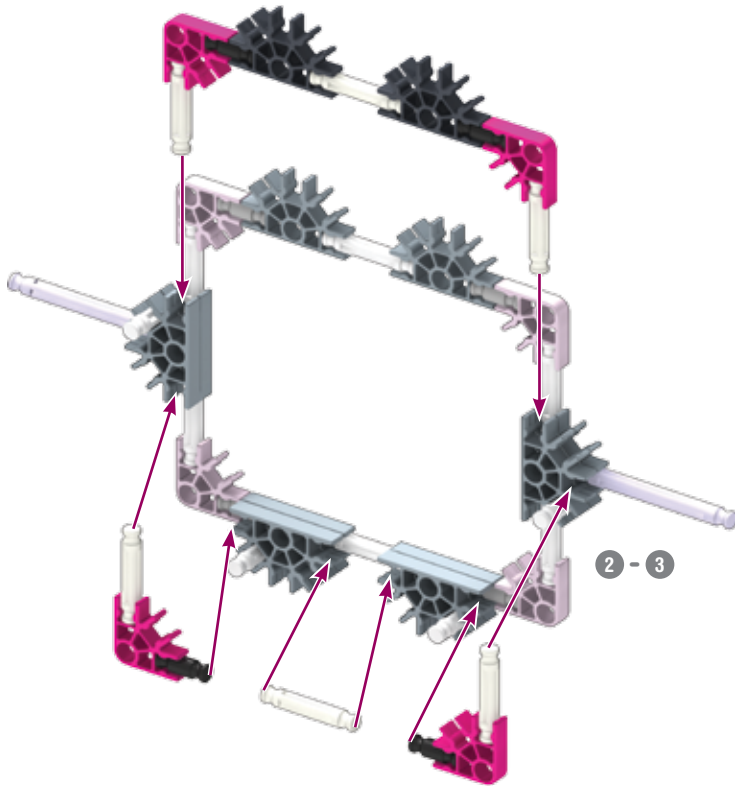

2-4

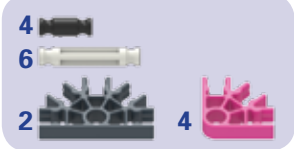

rotate model
pivoter le modèle

5

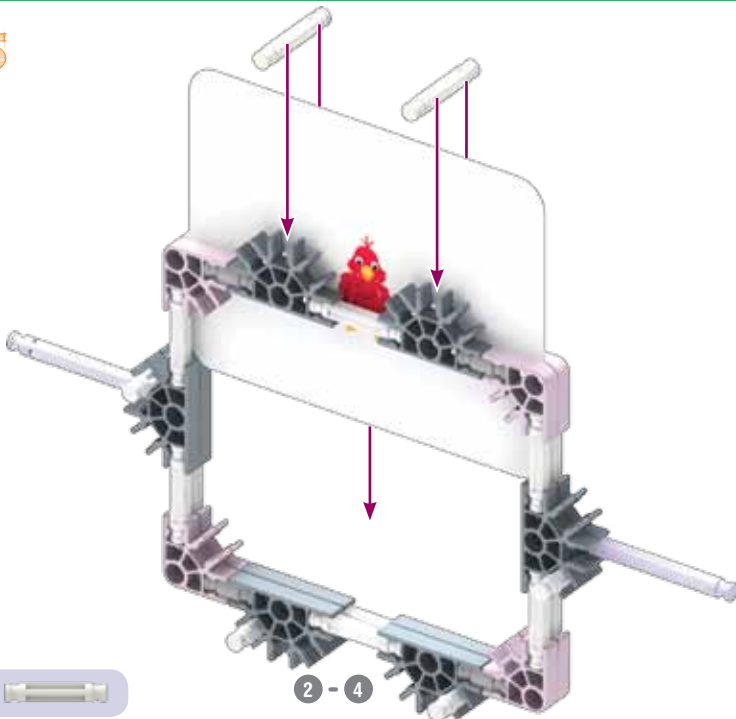

2-4

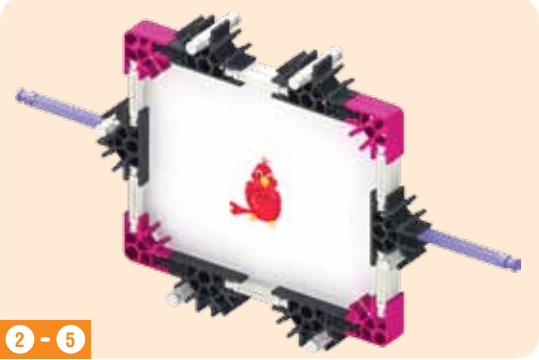

2-5

6

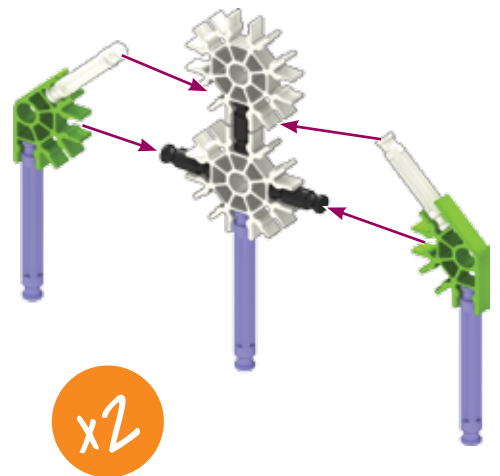

x2

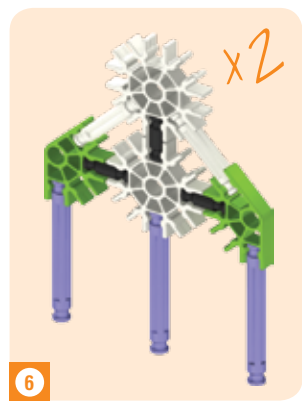
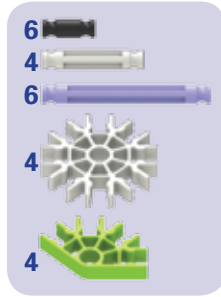

6

7

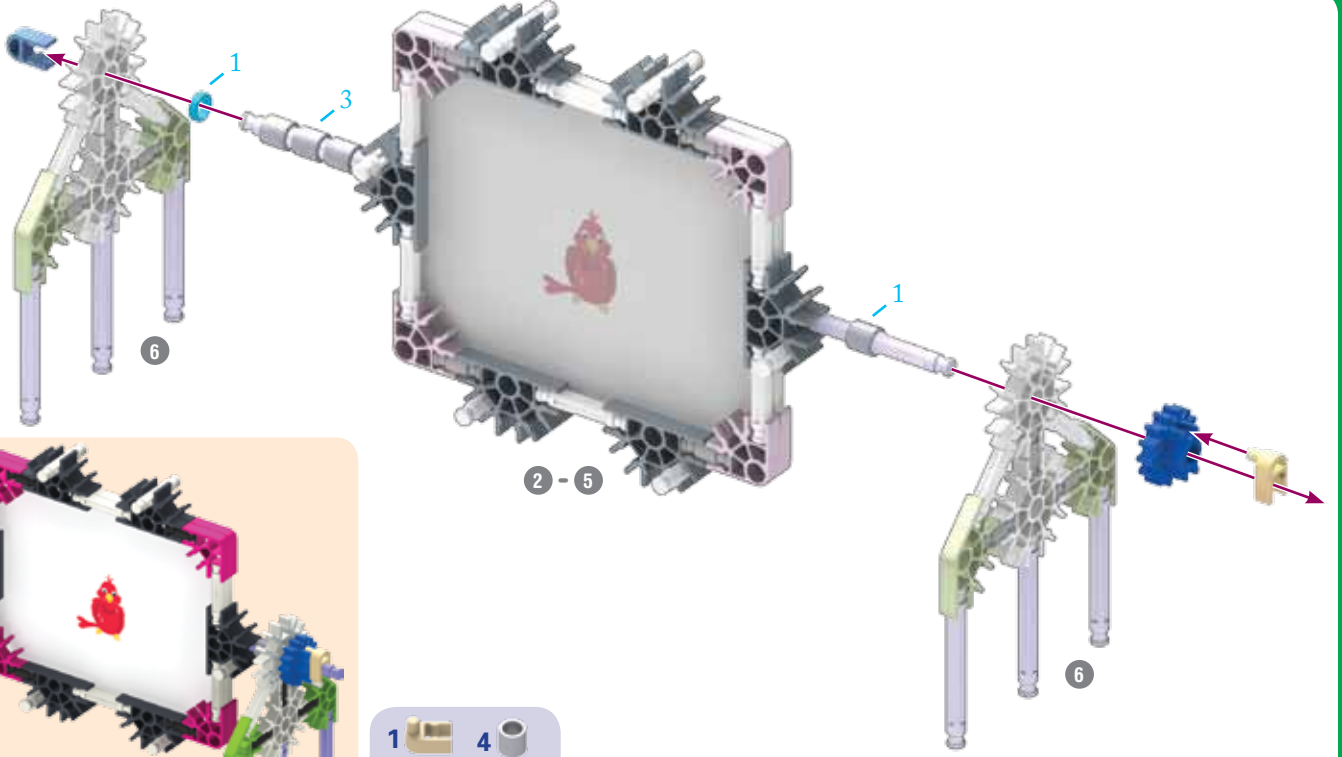

2 - 7

- | | |
|---|---|
| 1 | 4 |
| 1 | 1 |
| 1 | 1 |

8

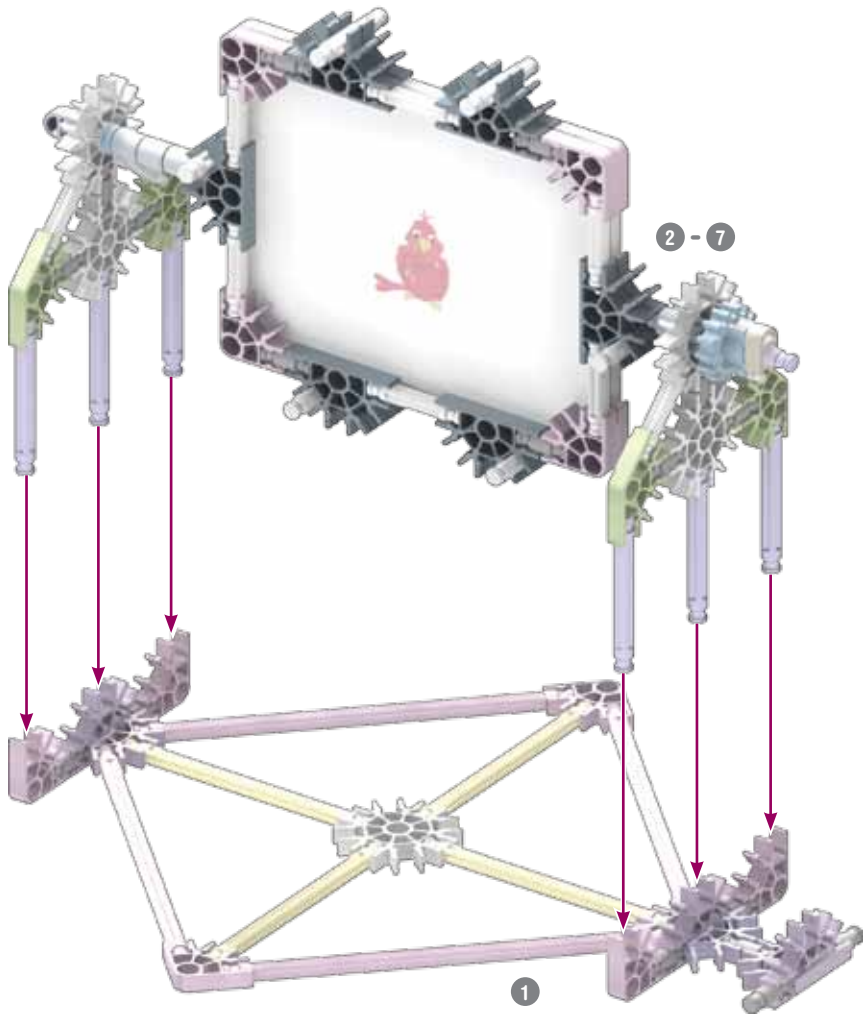

2 - 7

1

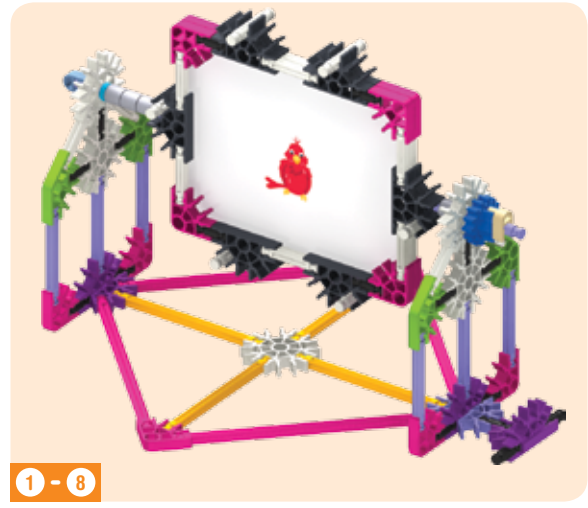

1 - 8



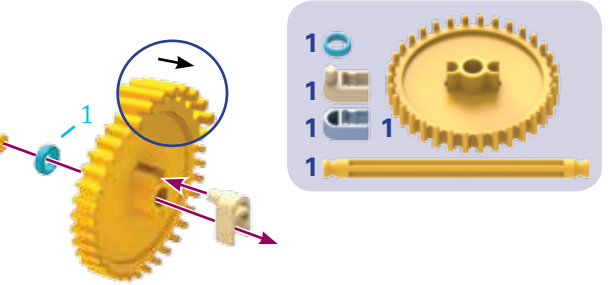
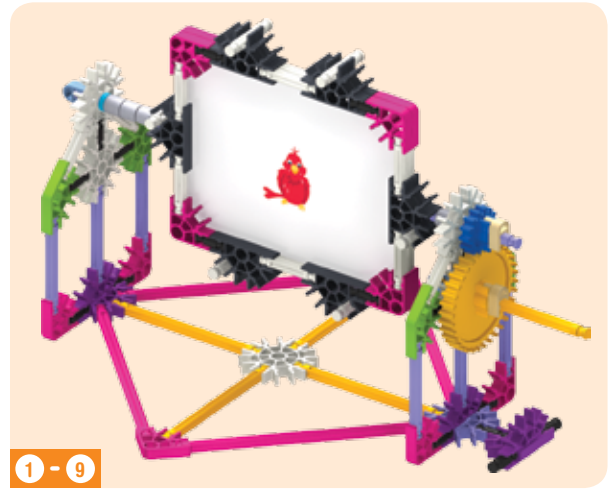
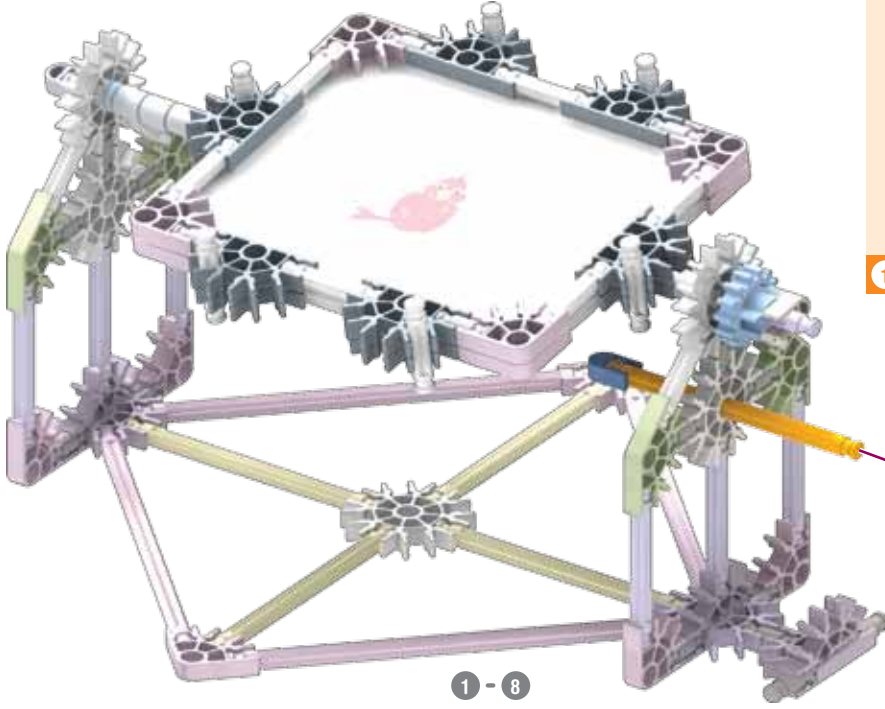

9

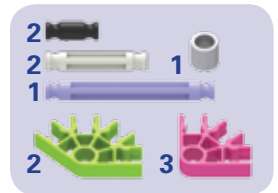
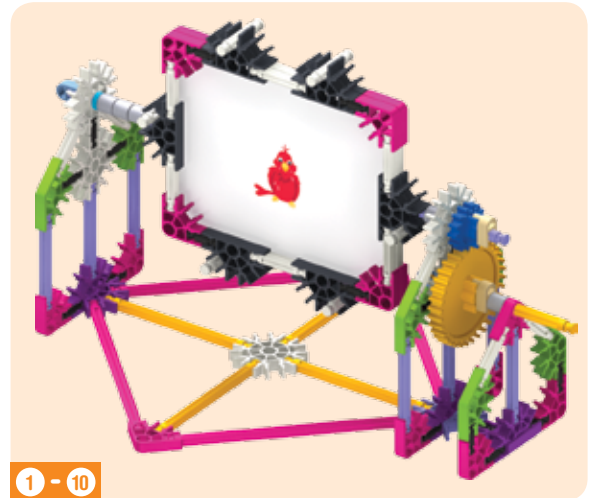
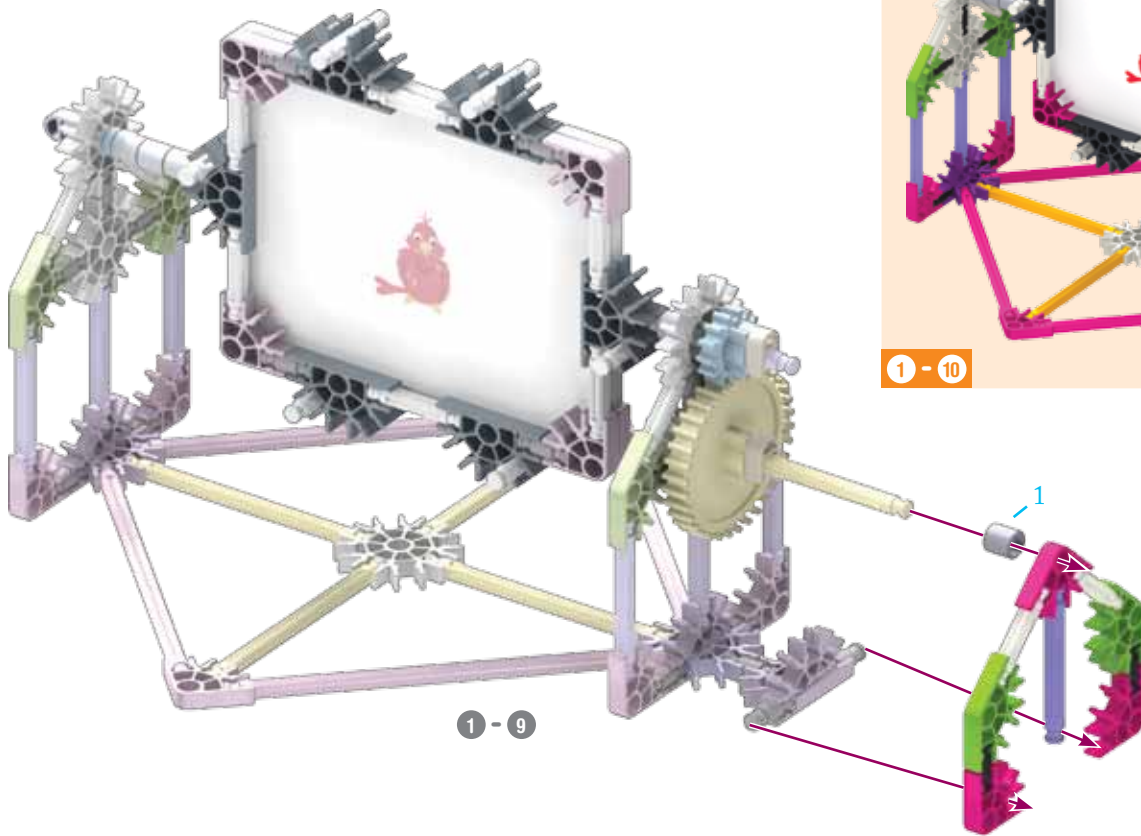

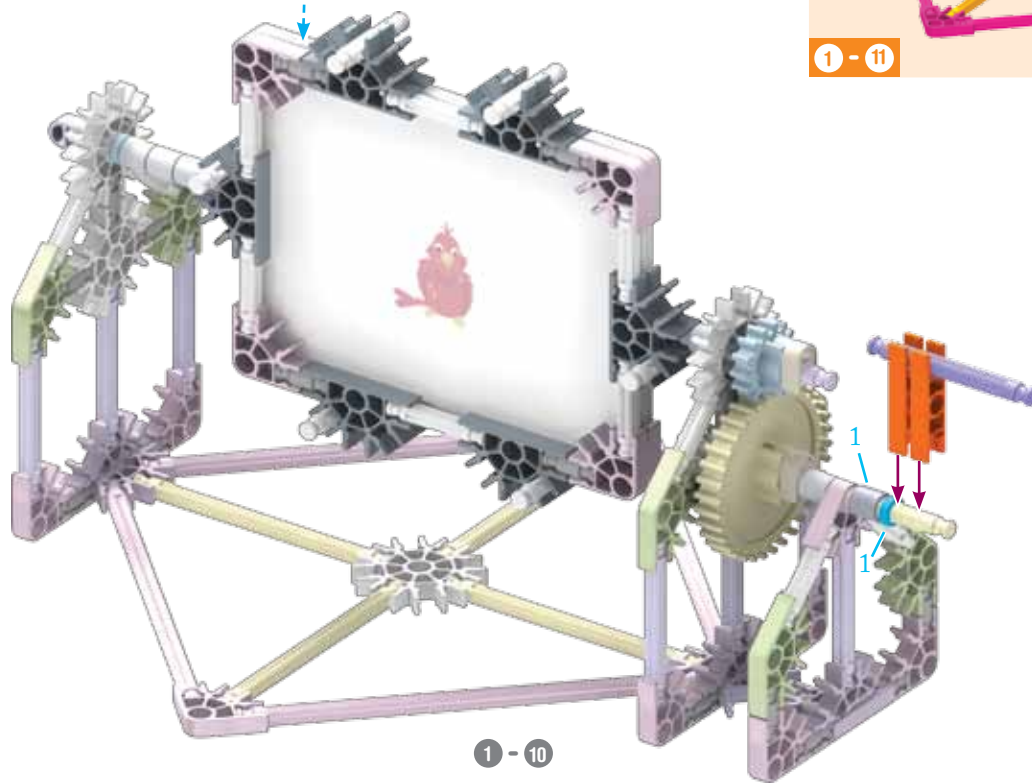
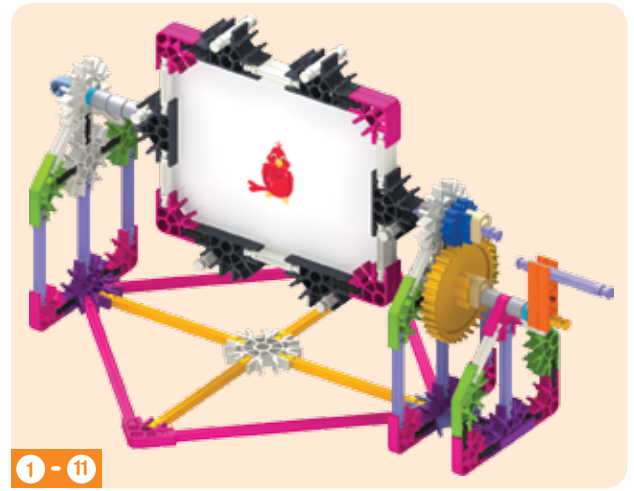
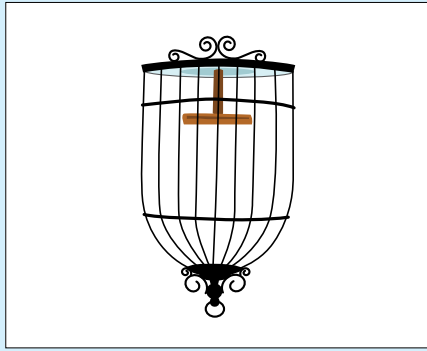
10





- 1  1 
- 1 
- 2 



Go to www.knex.com/downloadables and enter 43753 to print graphic panels!
 Allez à www.knex.com/downloadables et entrez 43753 pour imprimer des panneaux graphiques !

Invention: Flapping Bird

Invention : Oiseau Battant



1

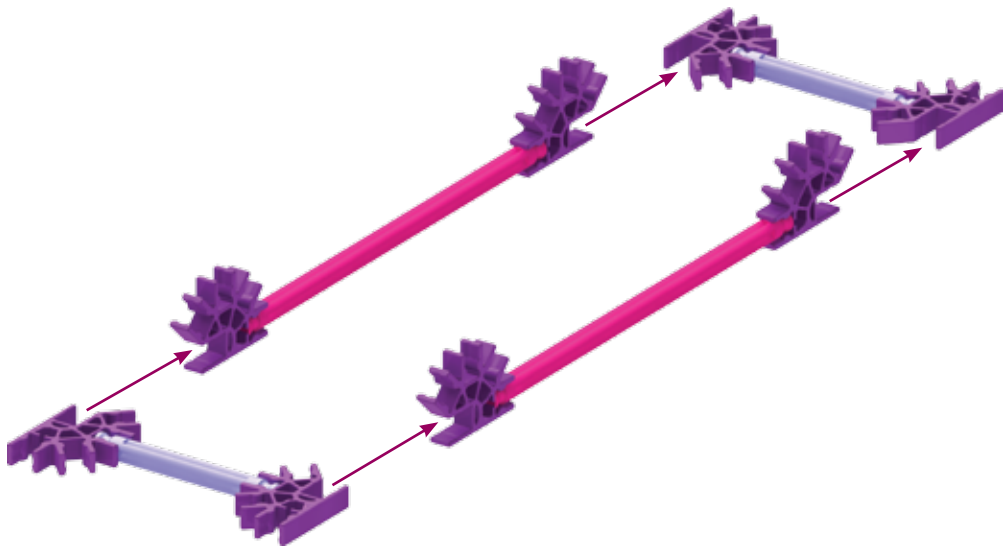
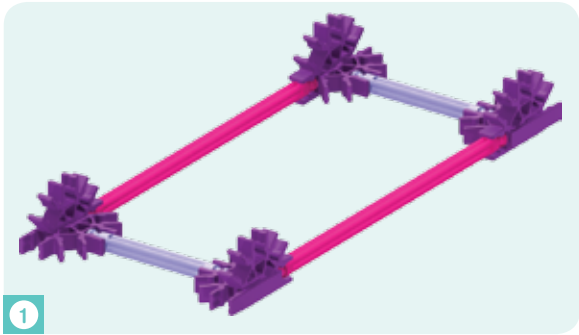

2

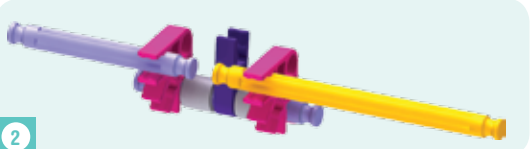
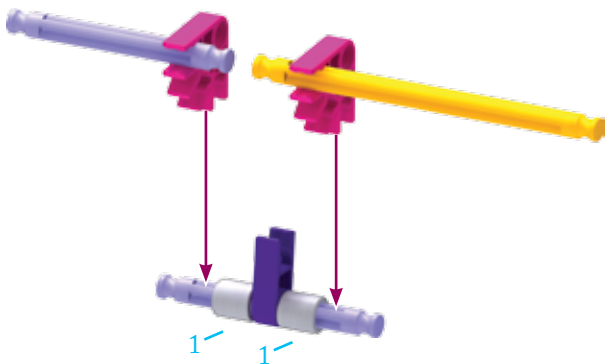

3

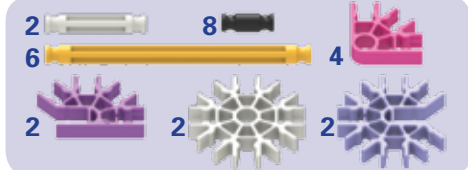
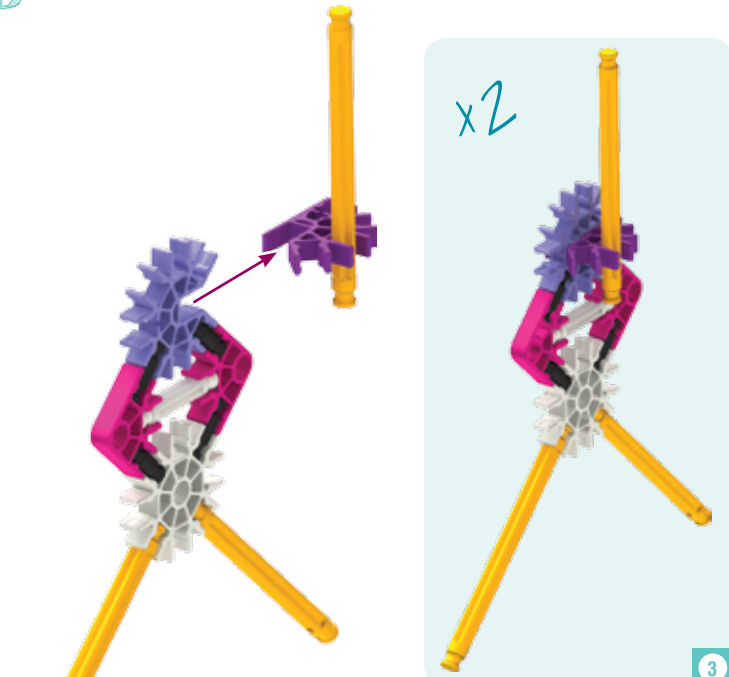

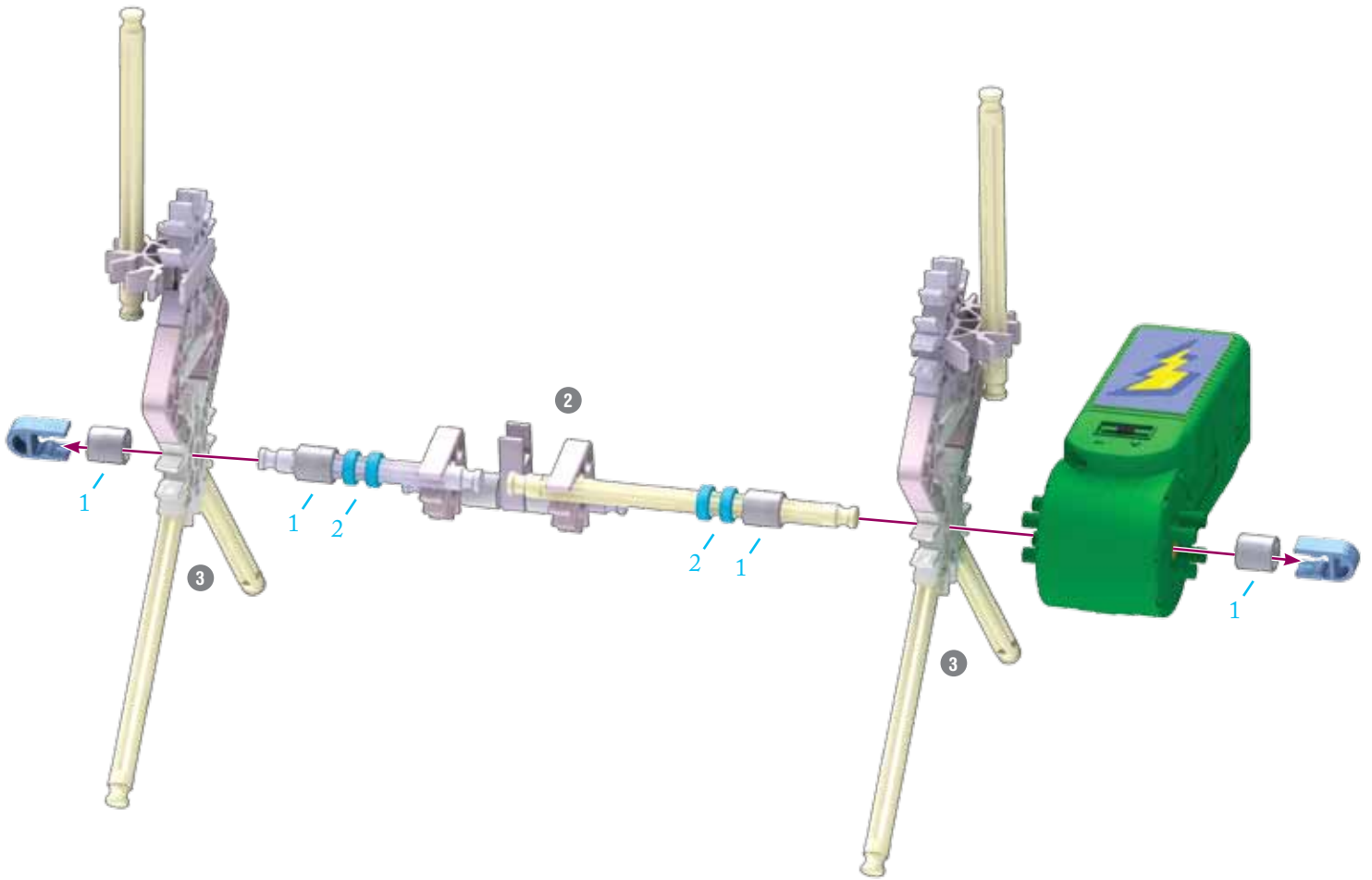

- EN** Did you install 2 AA (or LR6) batteries in the motor?
- FR** Est-ce que tu as installé 2 piles AA (ou LR6) dans le moteur ?
- ES** ¿Instalaste 2 pilas AA (o LR6) en el motor?
- DE** Hast du 2 AA (oder LR6) Batterien in den Motor eingelegt?
- IT** Hai installato 2 batterie AA (o LR6) nel motore?
- PT** Foram instaladas as pilhas 2 AA (ou LR6) no motor?
- NL** Heb je 2 AA (of LR6)-batterijen in de motor geplaatst?

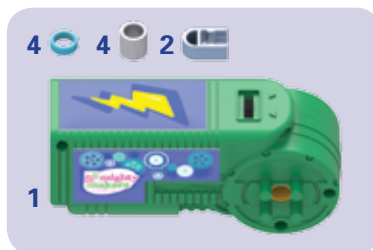
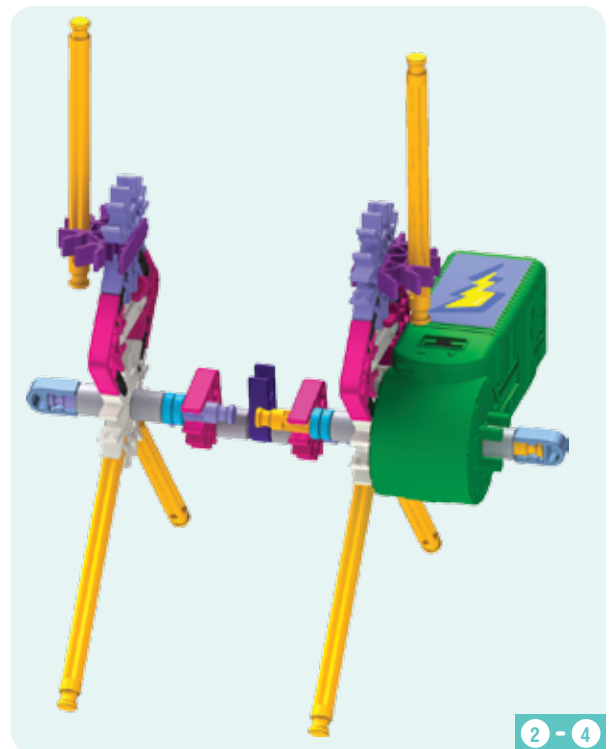

5

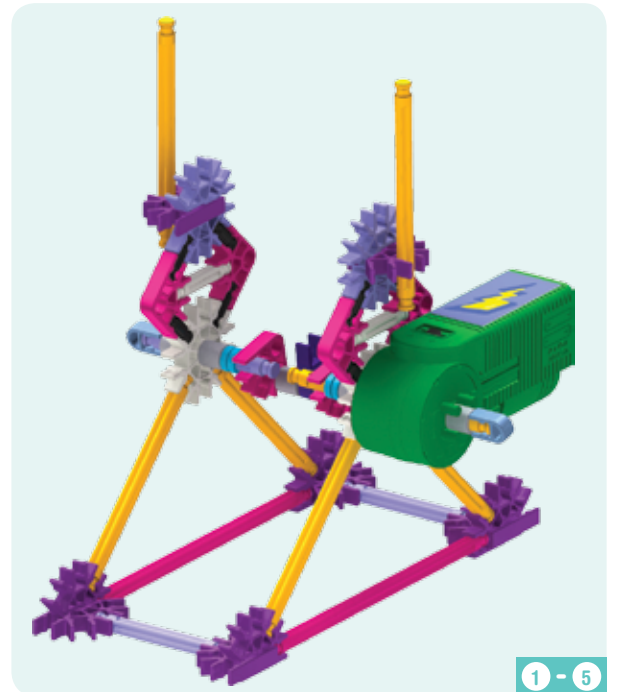
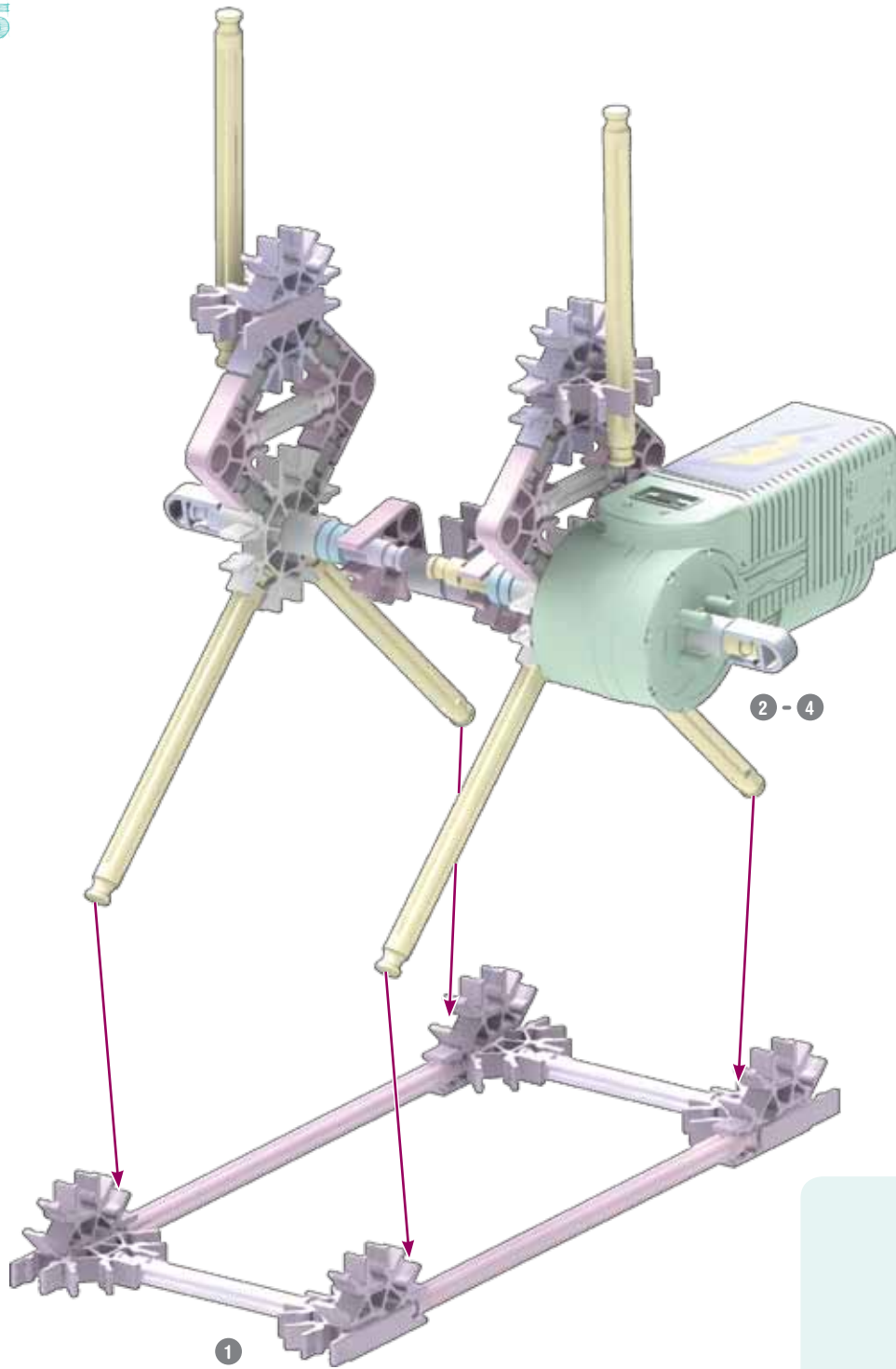

6

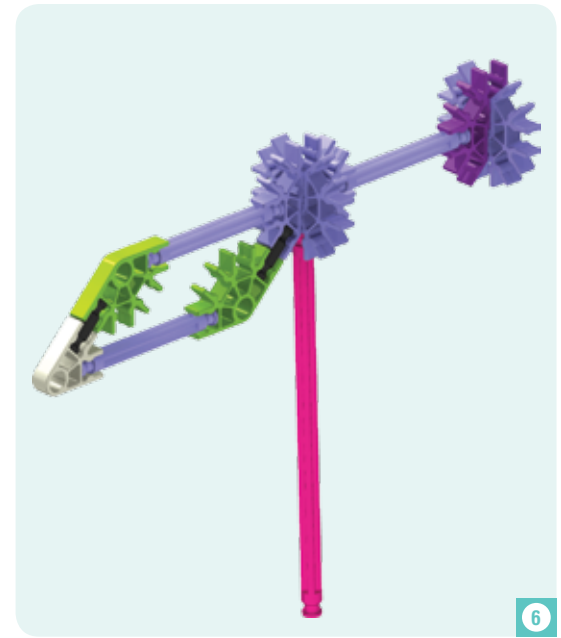
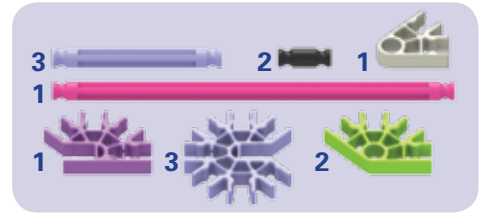
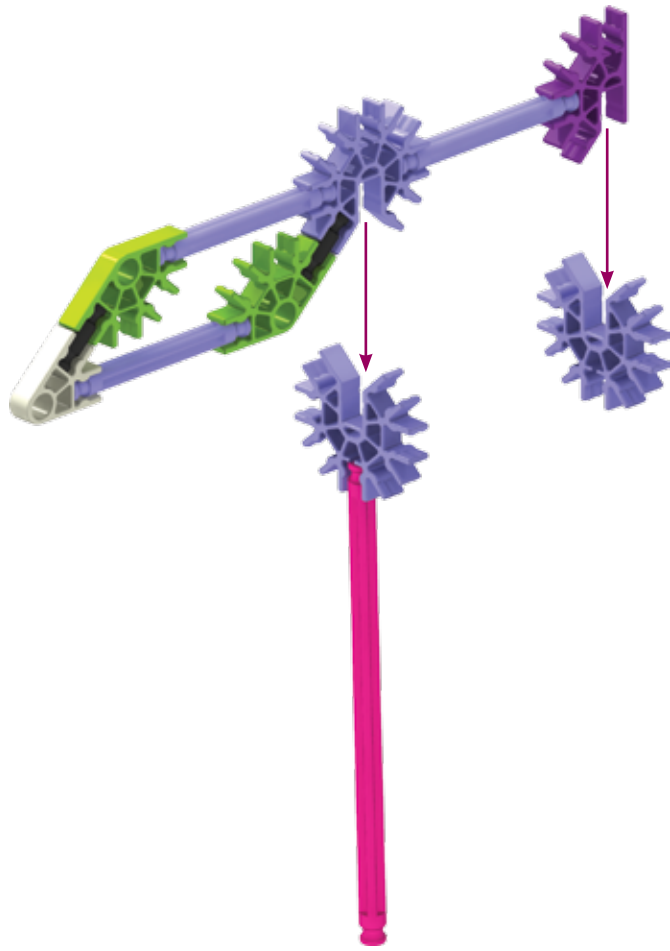

6

7

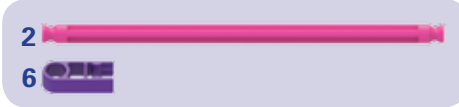
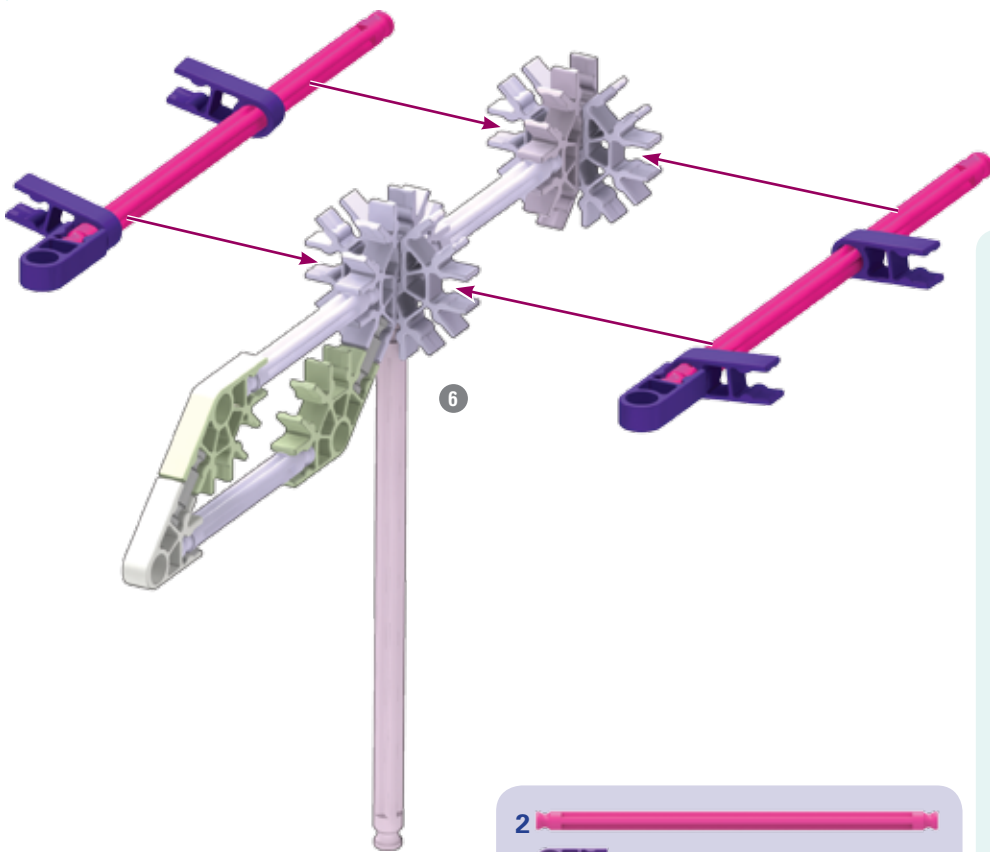

6 - 7

8

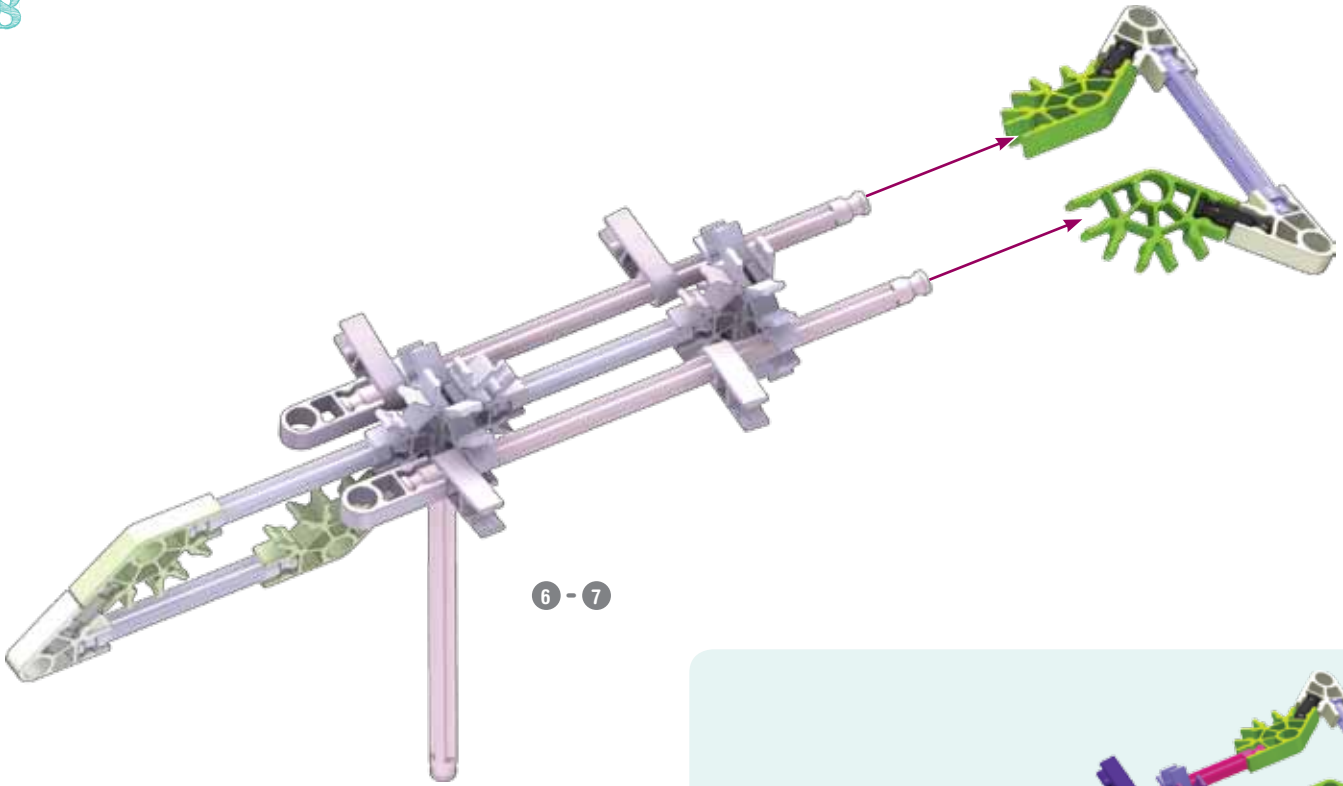

6 - 7

- 2
- 1
- 2
- 2



6 - 8

9

- 4
- 8
- 4
- 2
- 4
- 4
- 2

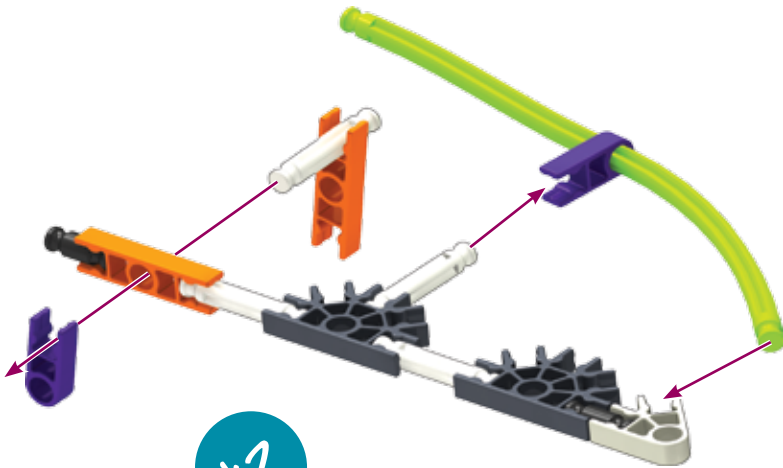

x2

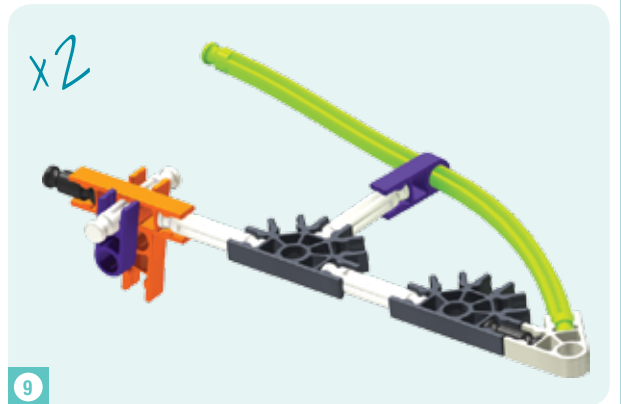

9

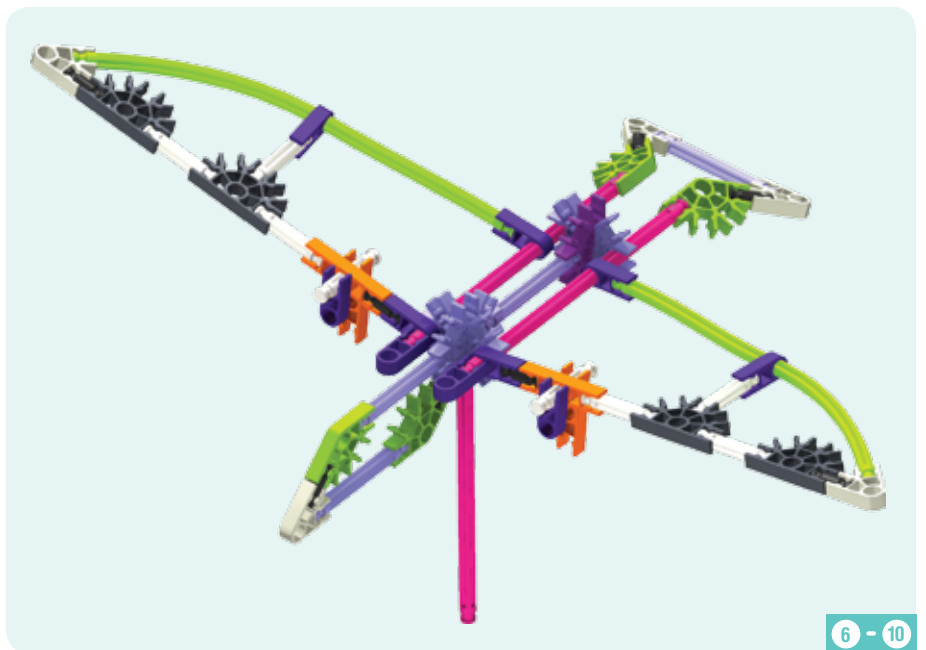
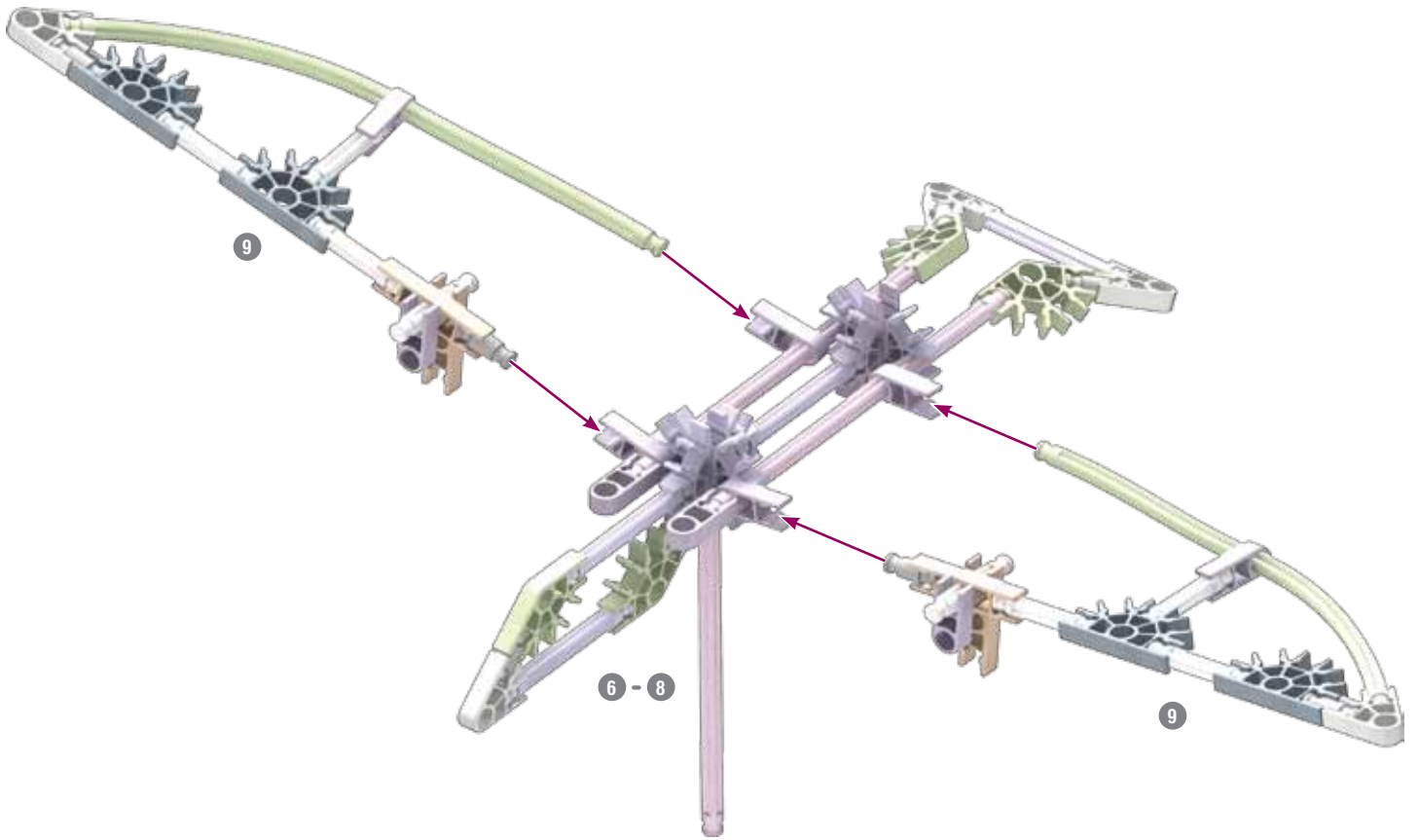

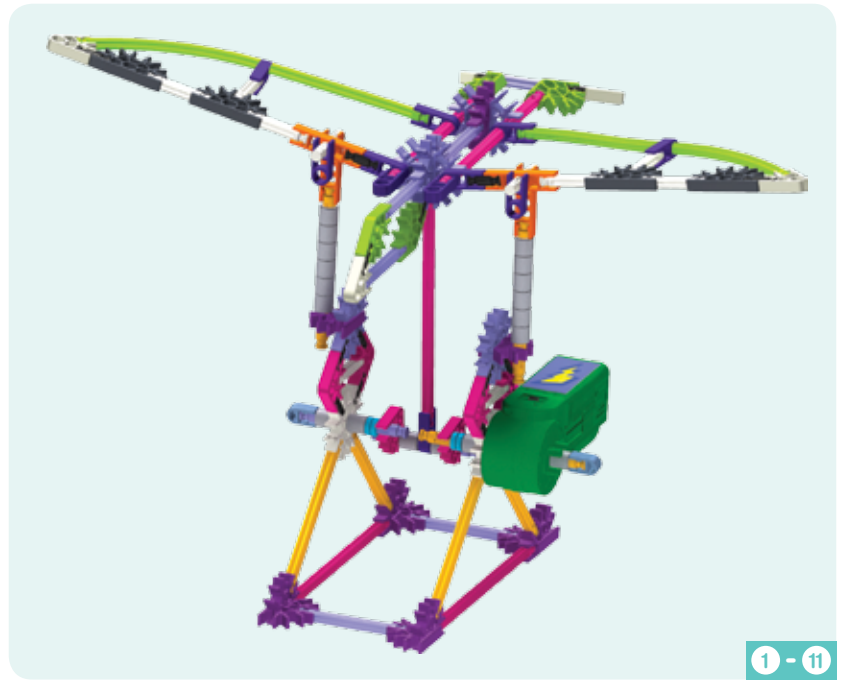

1 - 11

12 

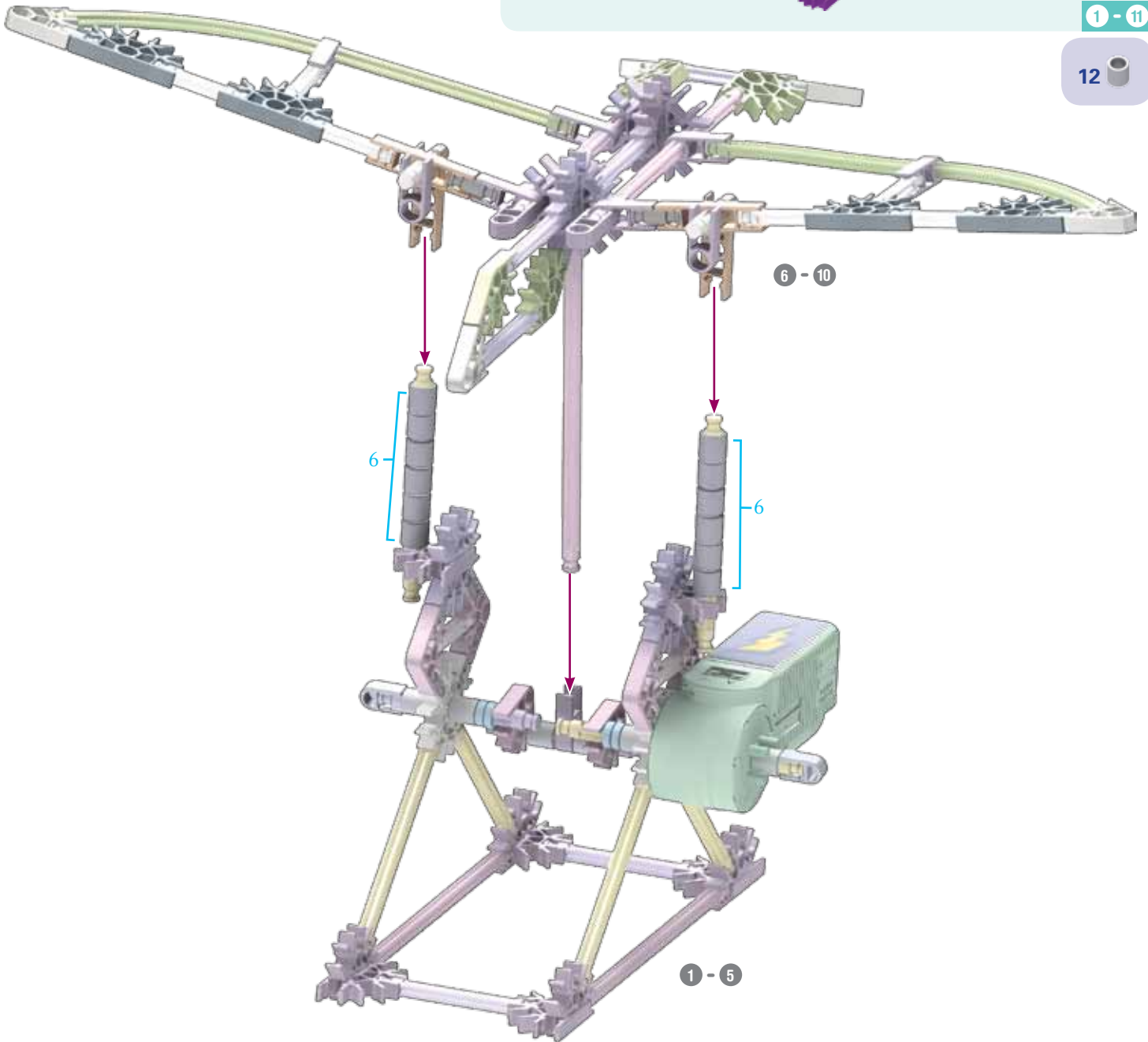

6 - 10

6

6

1 - 5

Invention: Eggbeater
Invention : Batteur à œufs



1

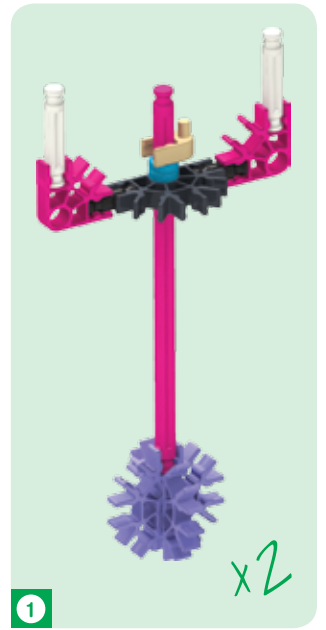
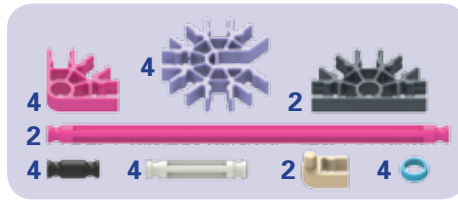
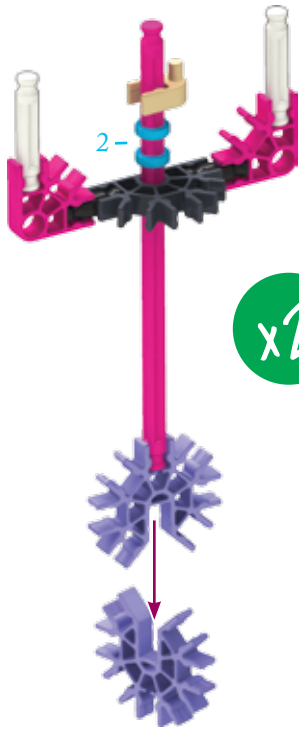

2

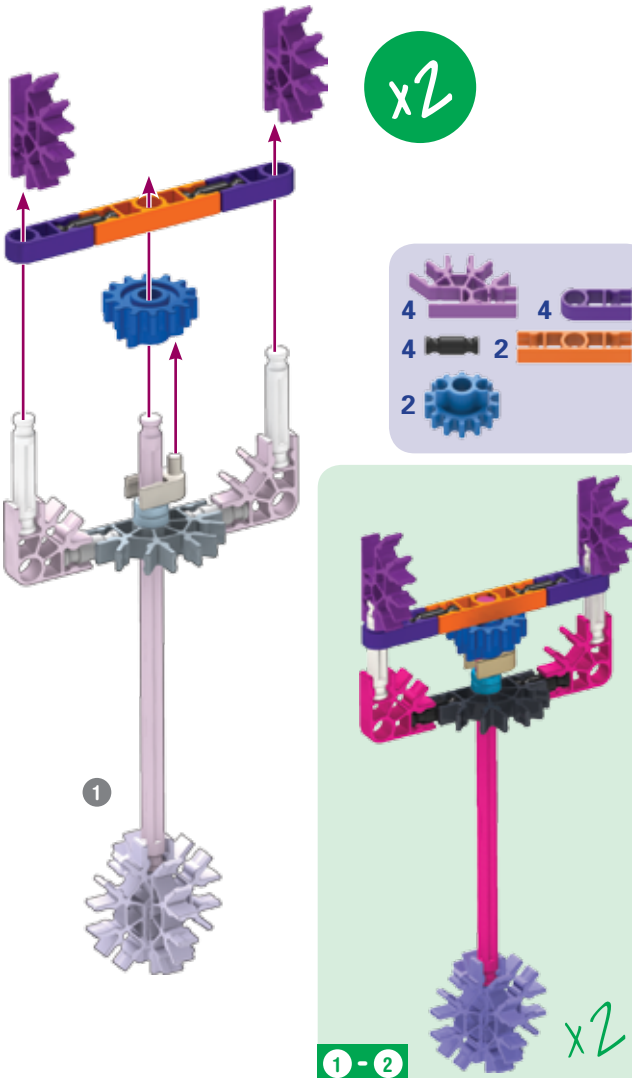

3



4

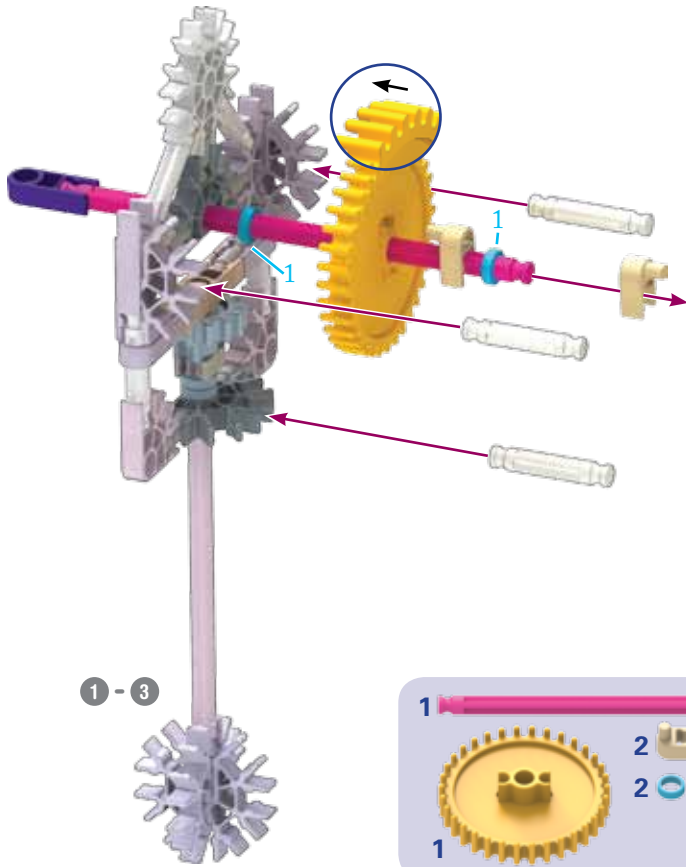

1 - 3

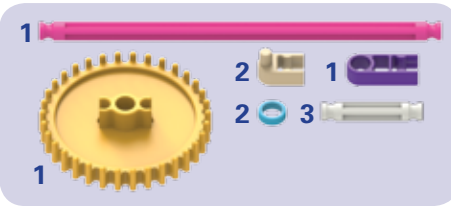

1 - 4

5

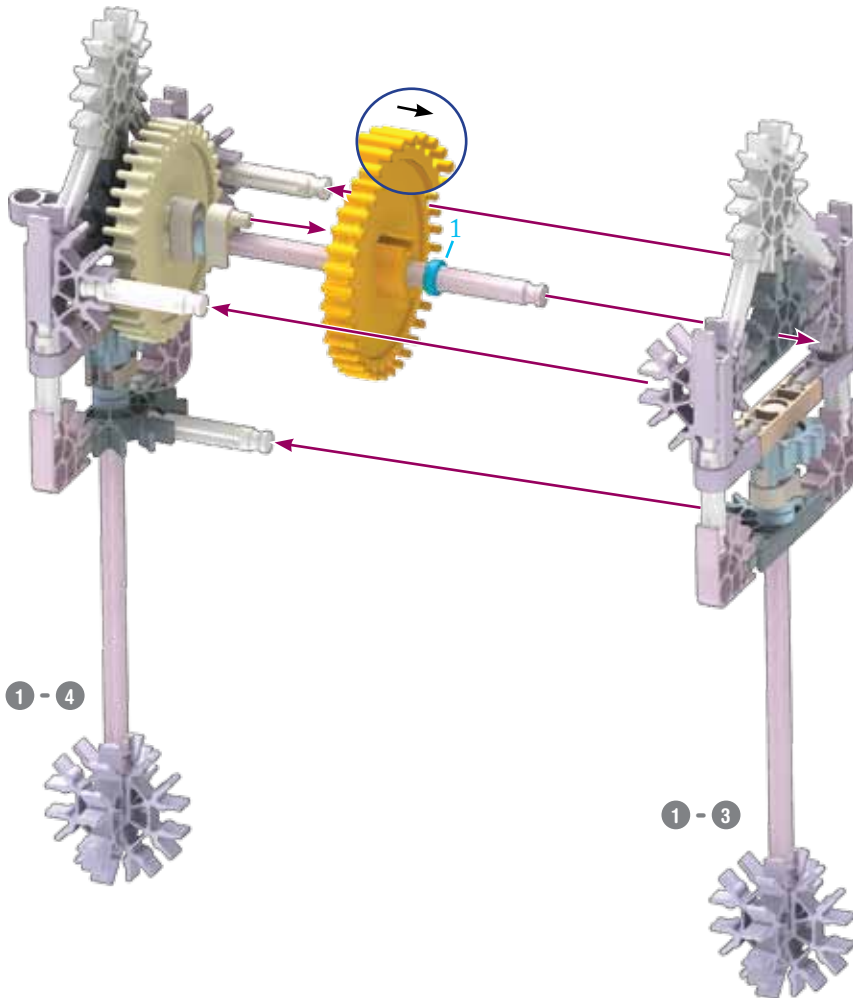

1 - 4

1 - 3

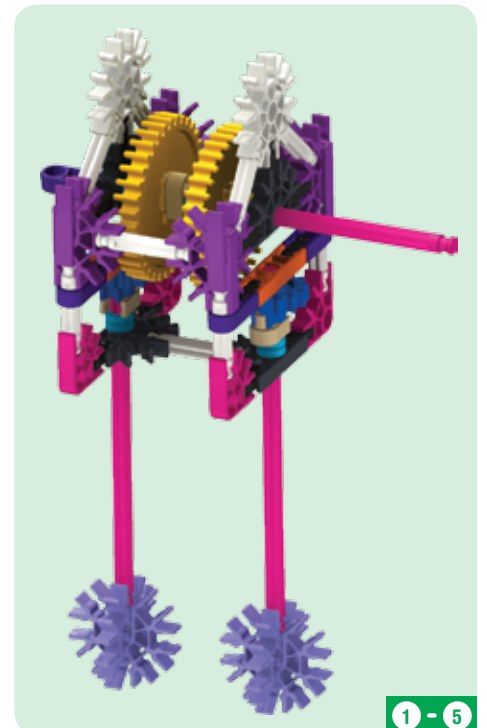
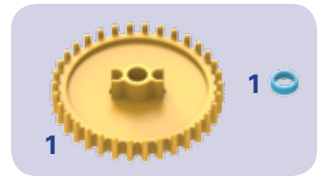

1 - 5

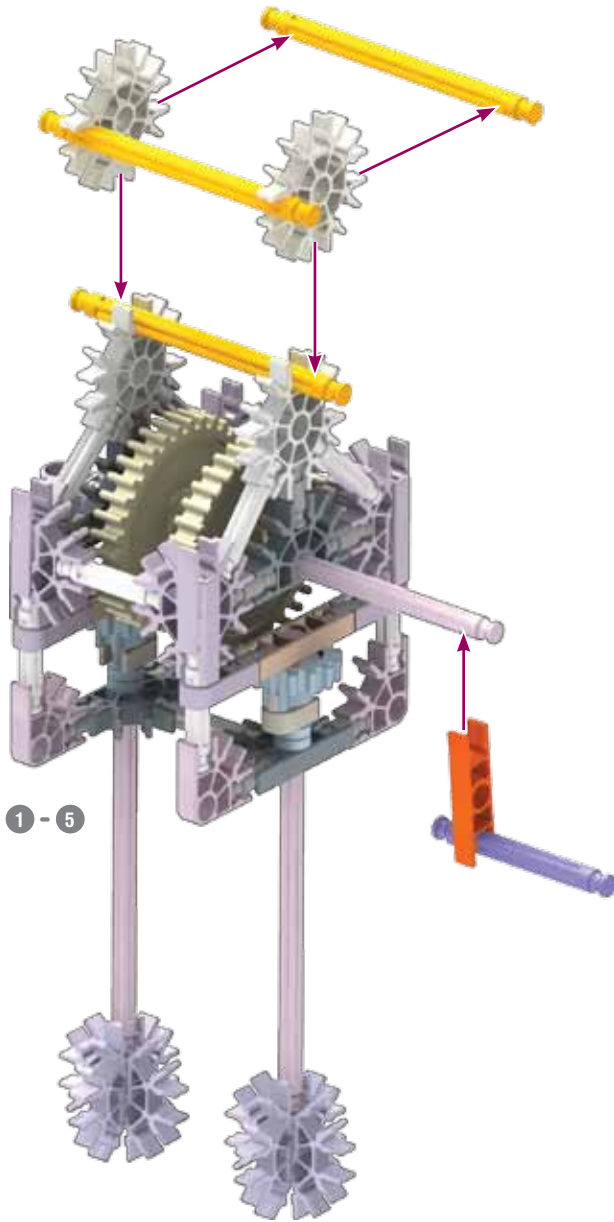

- 1
- 3
- 2
- 1



We love your builds! You are an awesome inventor!

Nous aimons vos constructions ! Vous êtes un inventeur génial !

Invention: Optical Illusion Machine
Invention : Machine à Illusion d'optique

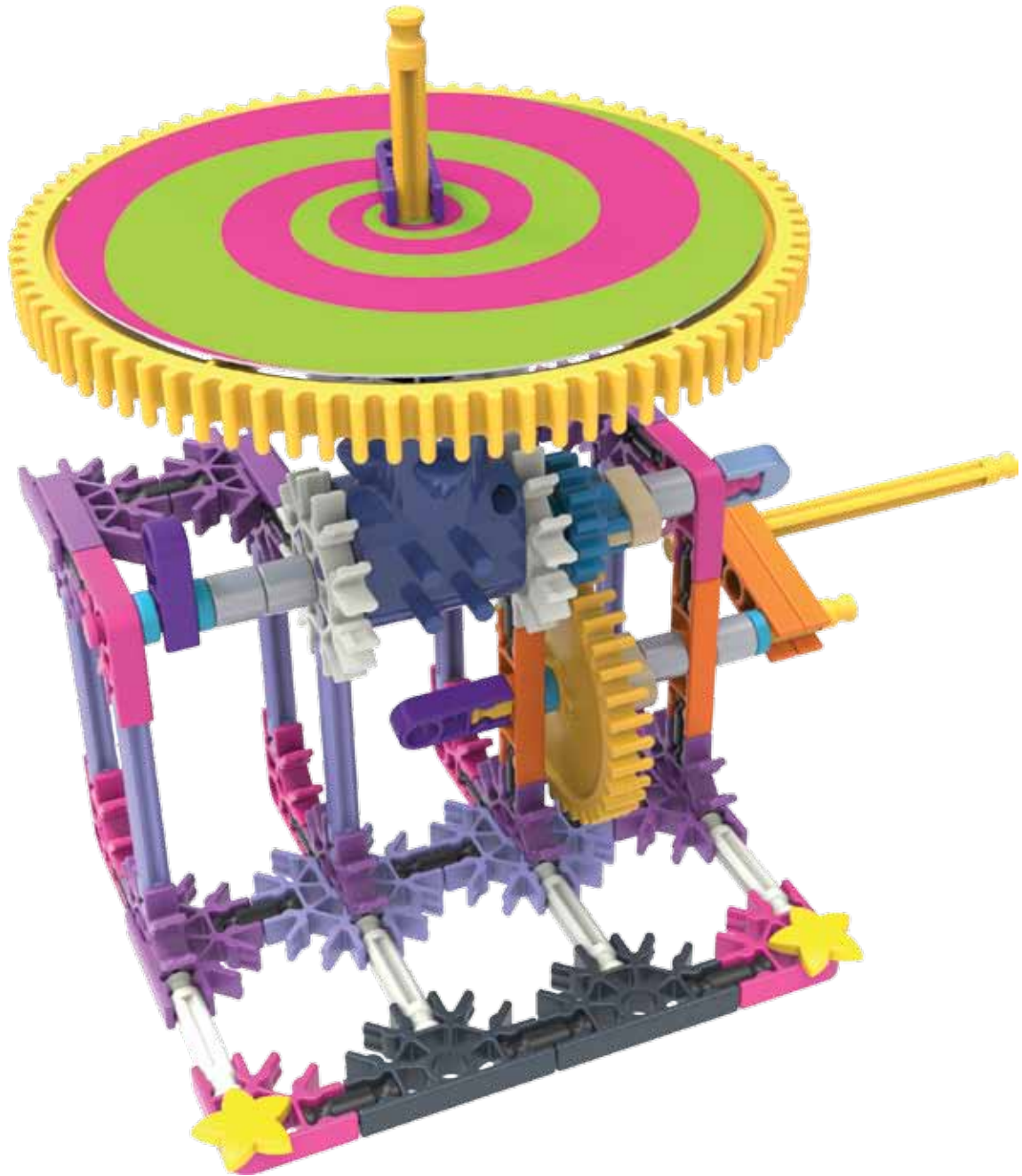

1

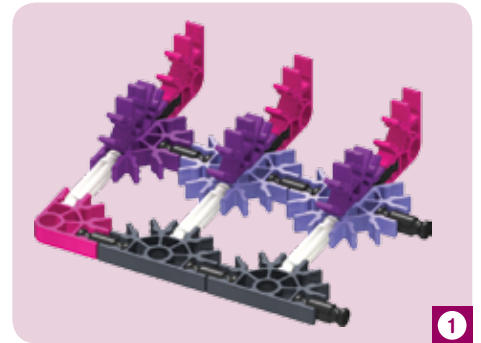
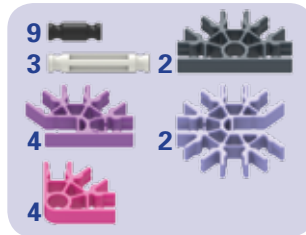
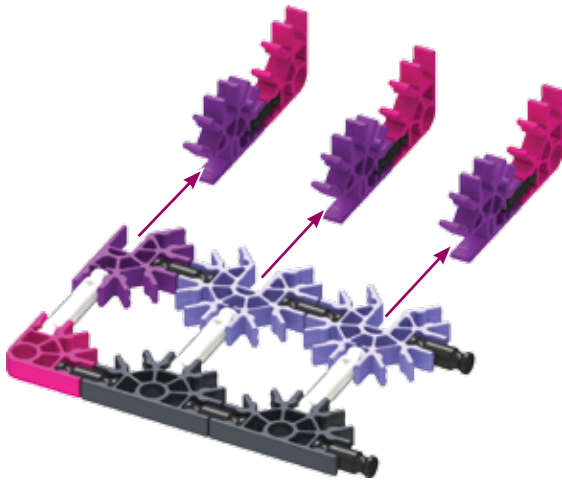

1

2

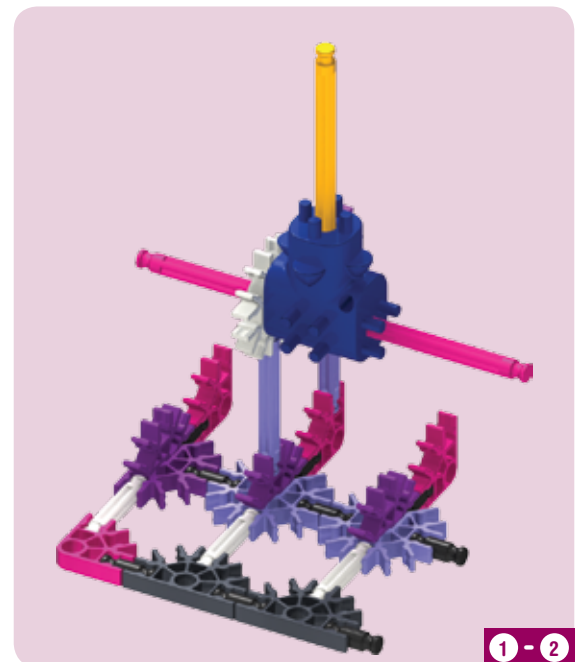
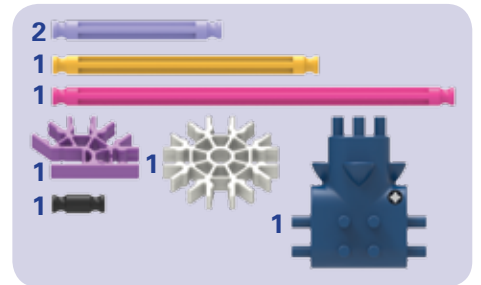
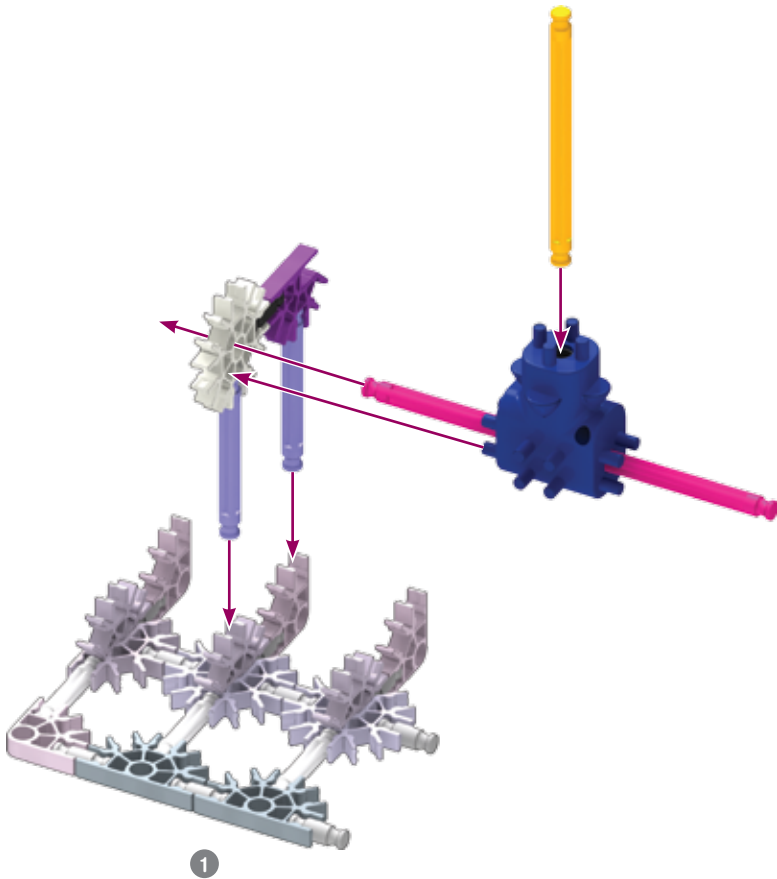

1-2

3

- 3 black pins
- 1 purple Technic axle
- 2 grey Technic bush
- 1 grey Technic axle
- 1 grey Technic bush
- 1 purple Technic axle
- 1 grey Technic bush
- 1 purple Technic axle
- 1 grey Technic bush
- 1 orange Technic axle
- 1 grey Technic bush
- 1 grey gear

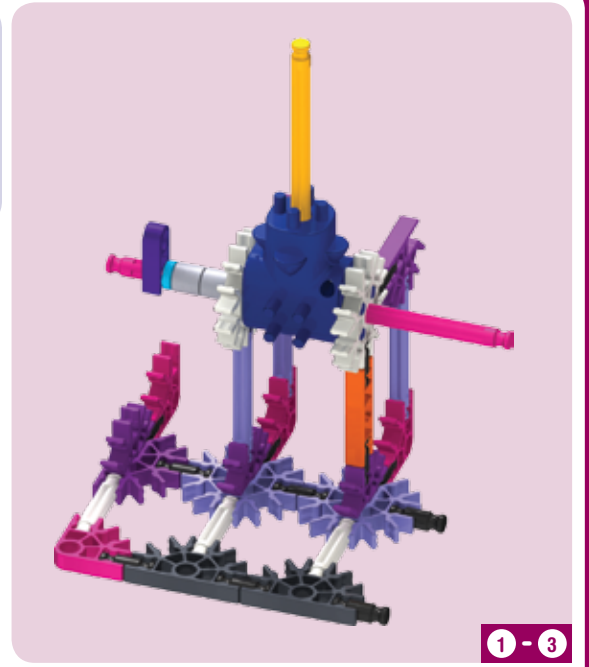
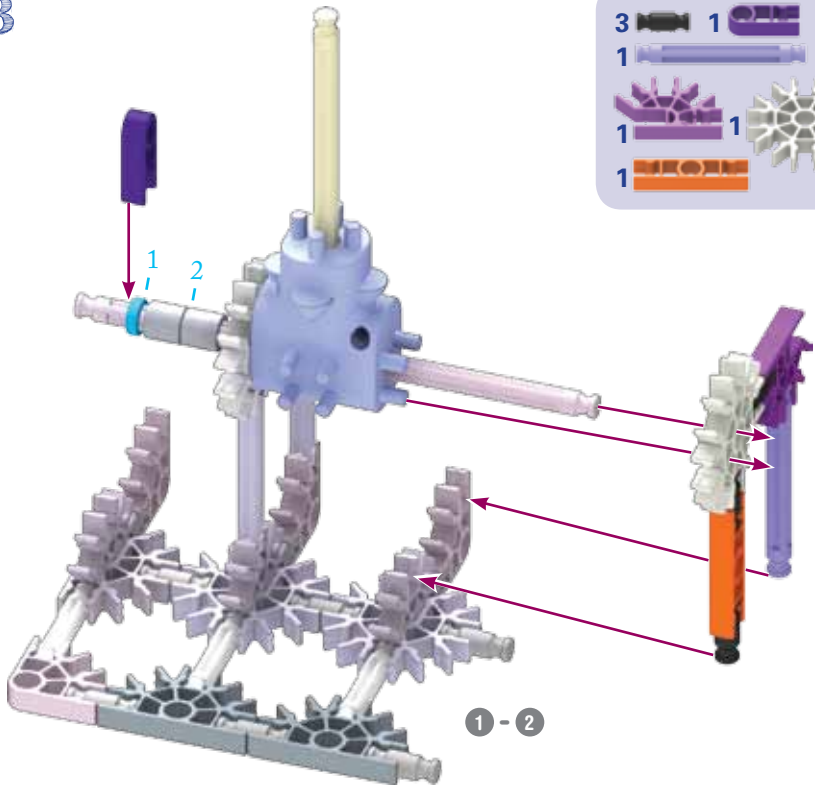

1-3

4

- 1 yellow Technic axle
- 1 purple Technic axle
- 2 grey Technic bush
- 1 grey Technic bush
- 1 blue gear
- 2 grey Technic bush
- 1 yellow gear

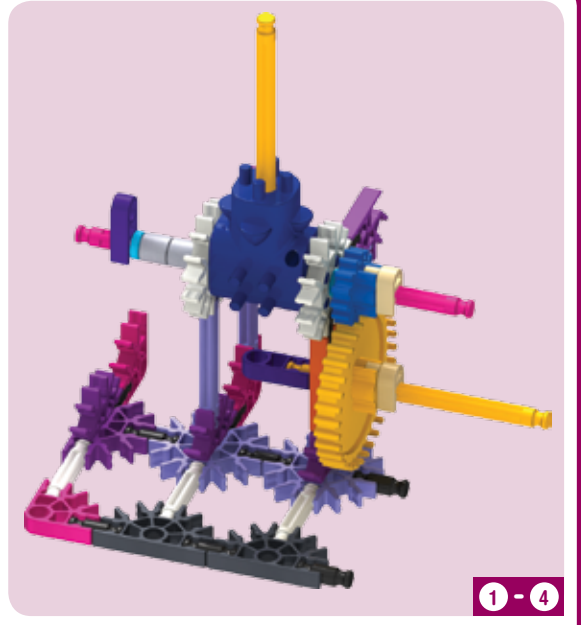
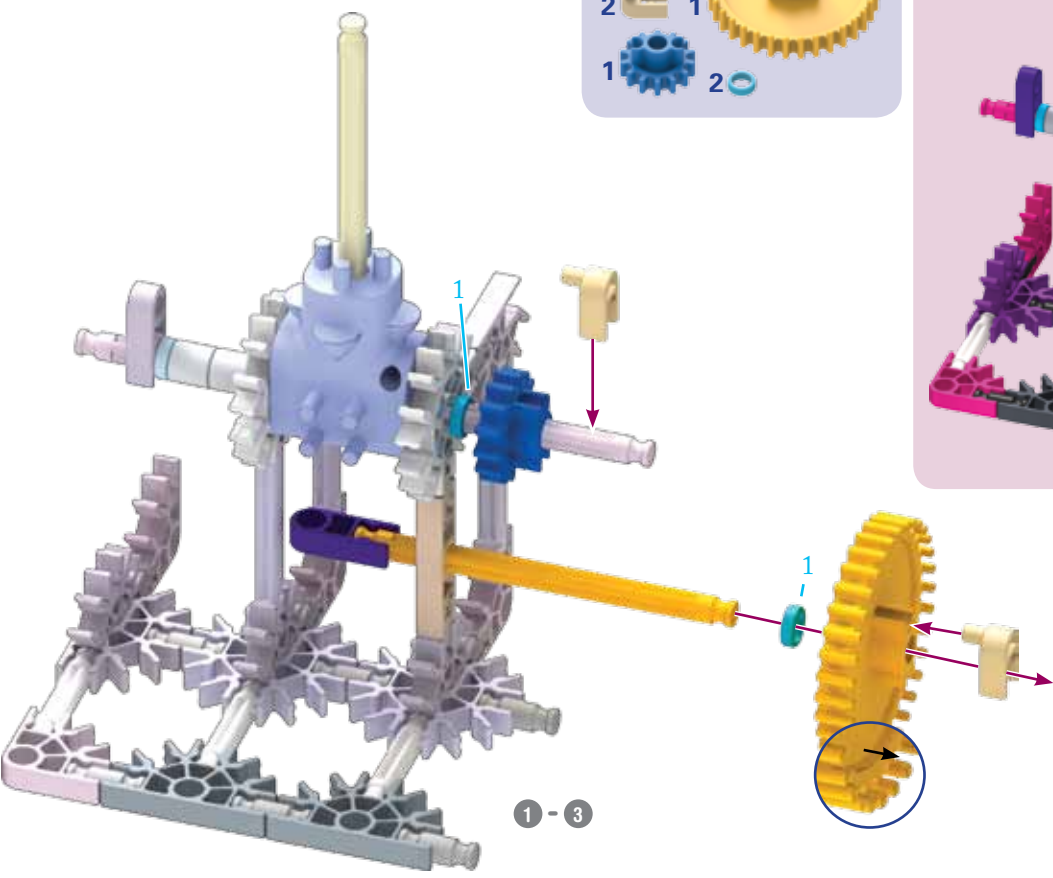

1-4

5

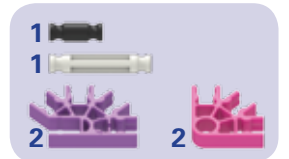
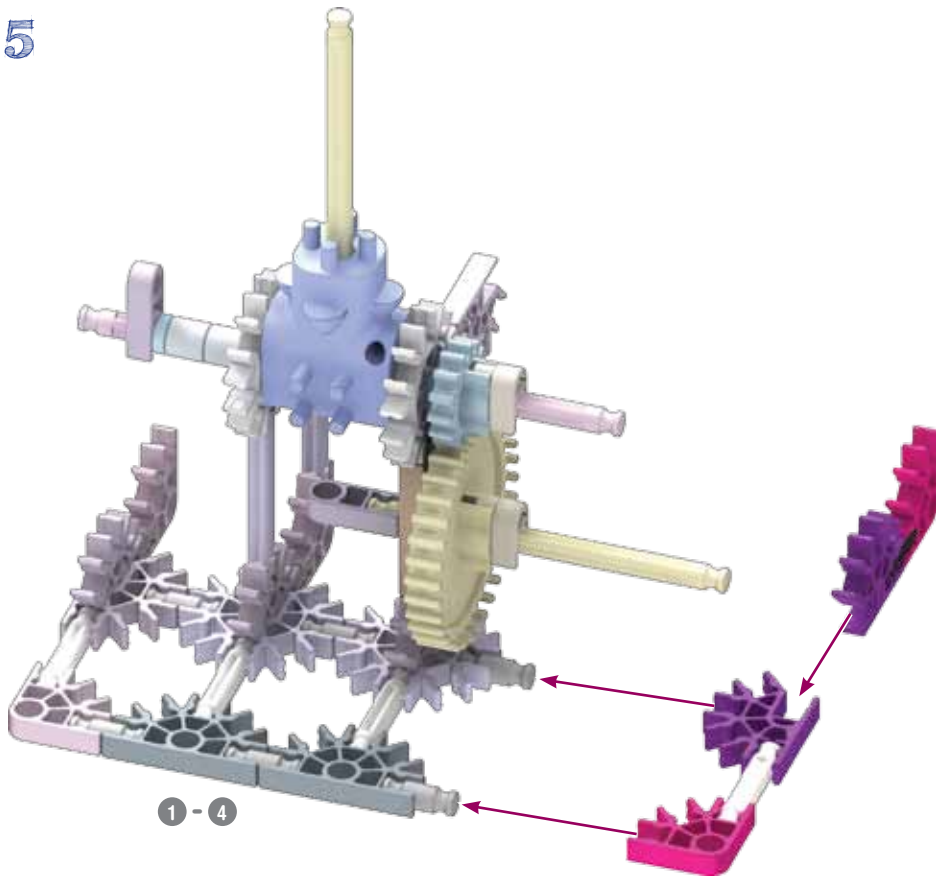

6

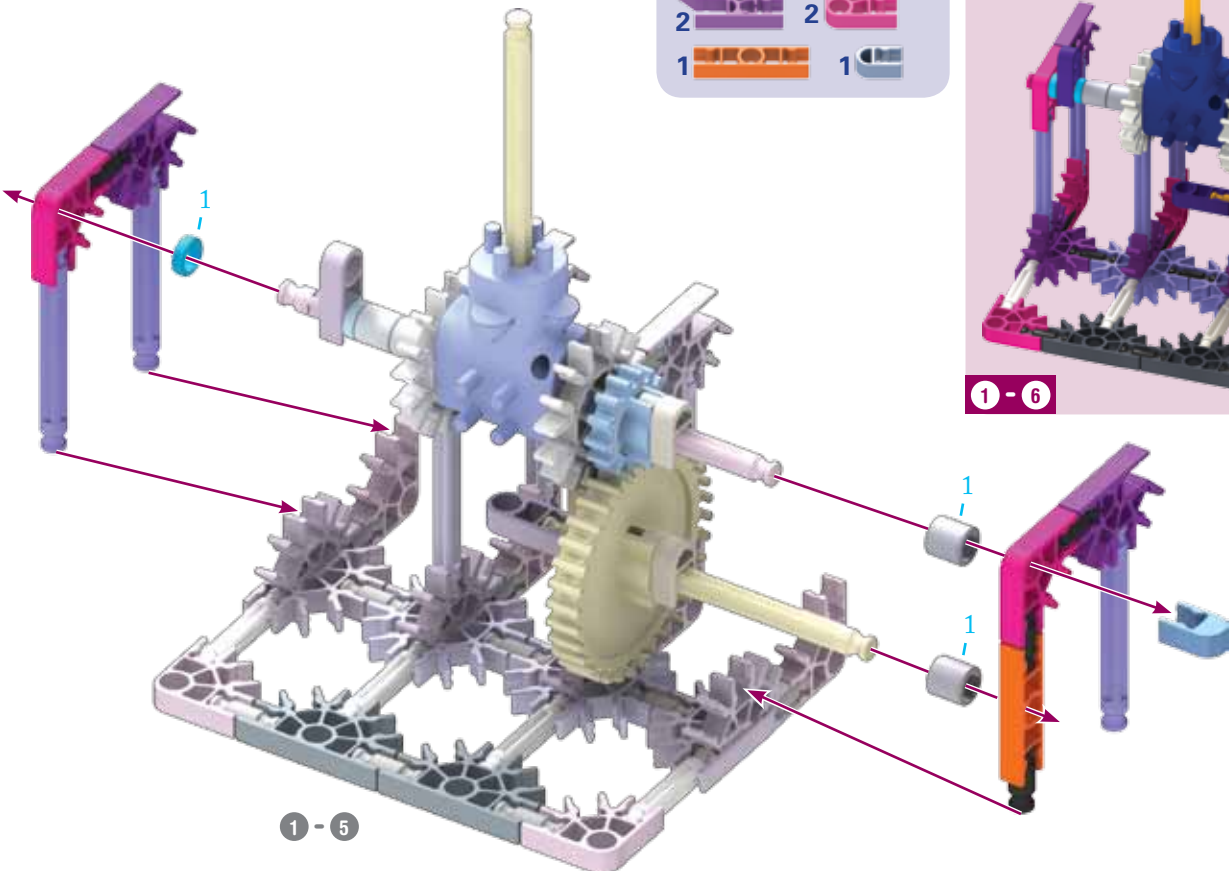
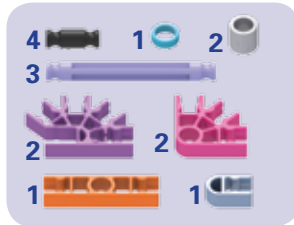

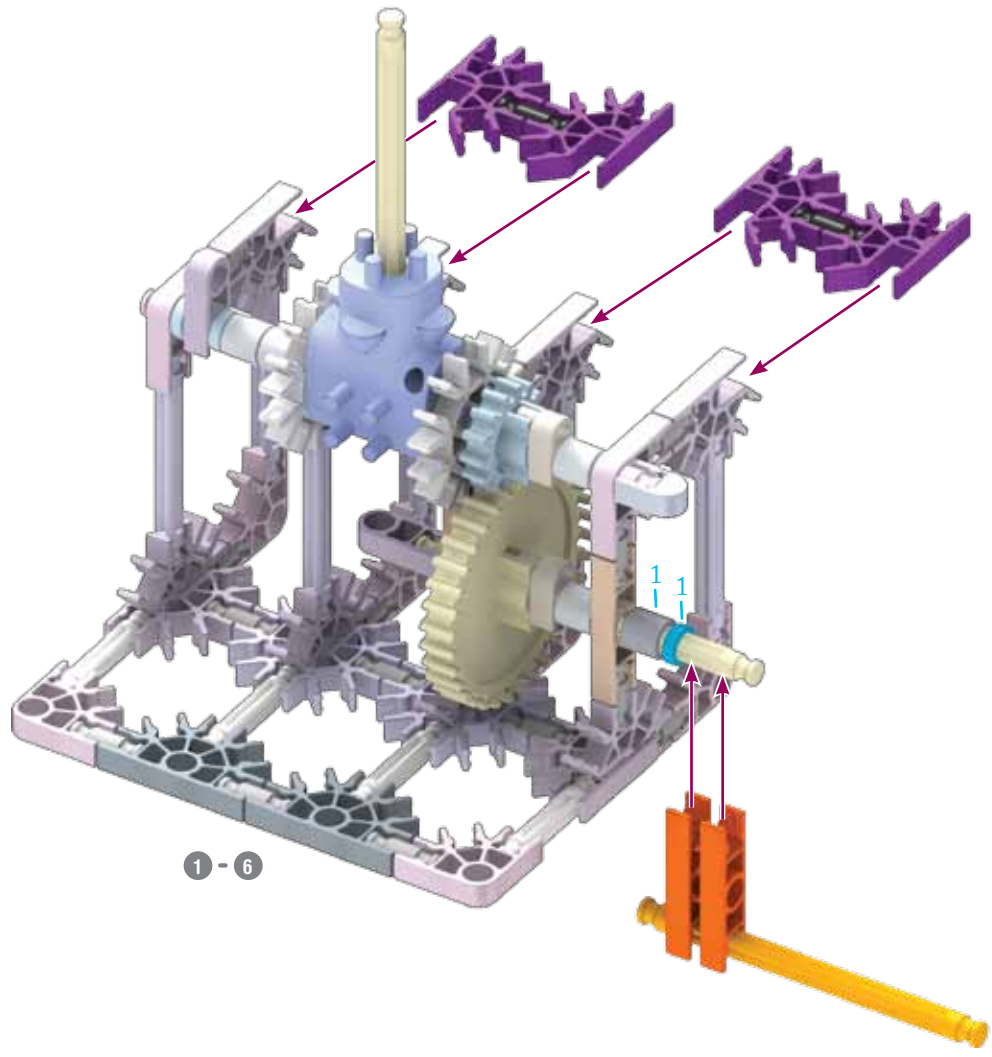

1 - 6



1 - 7

- 1
- 4
- 2
- 1
- 1
- 2

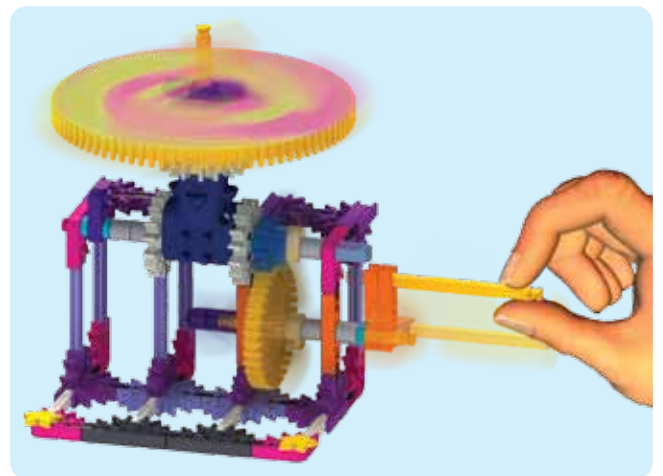
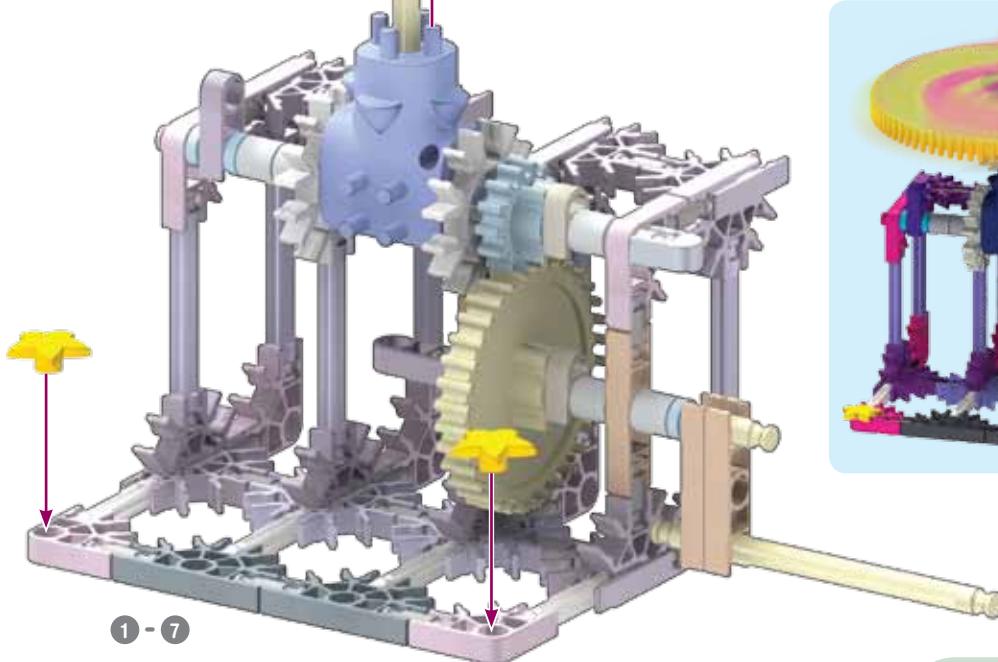
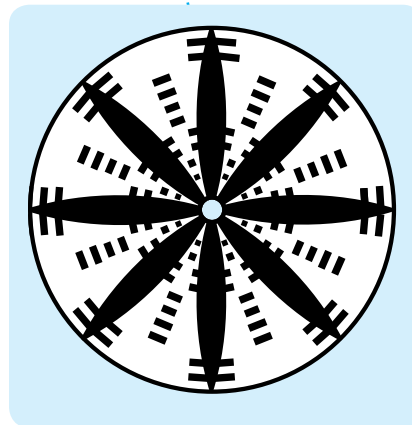
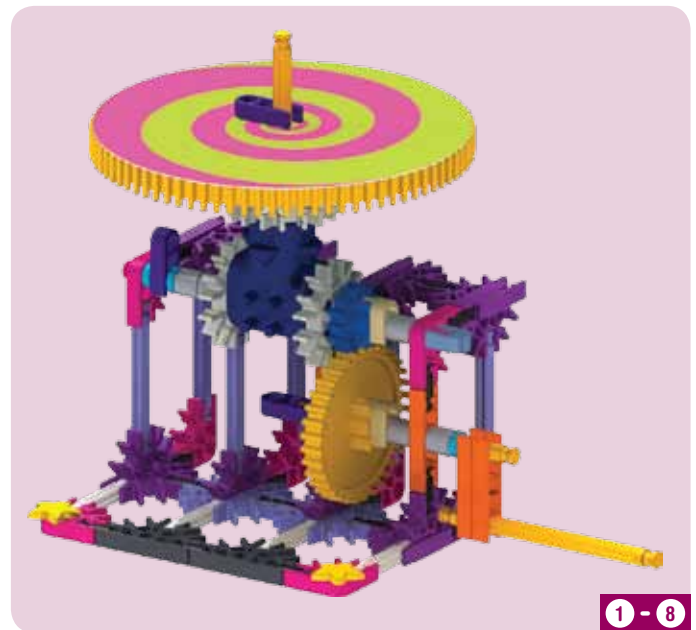
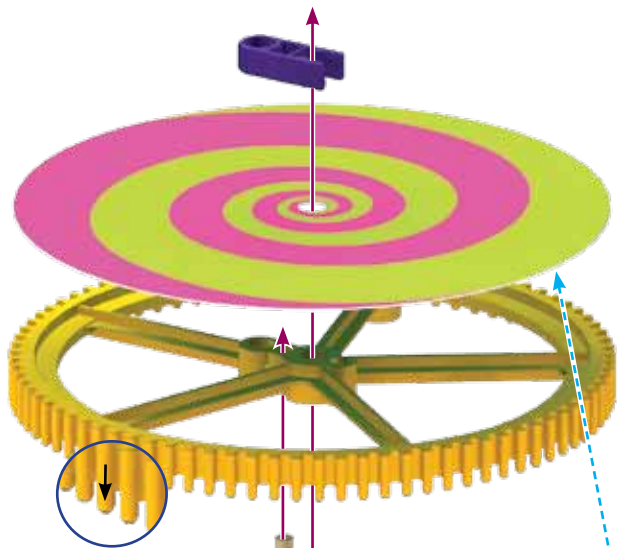

Go to www.knex.com/downloadables and enter 43753 to print graphic panels!
 Allez à www.knex.com/downloadables et entrez 43753 pour imprimer des panneaux graphiques !

(ES) (Página 3)

Conozca a Emily y Audrey
¡Cosas favoritas de Emily!
¡Cosas favoritas de Audrey!
**Aprenda acerca...#Inventar

(Página 4)

Nos gusta el diseño de nuevas invenciones en nuestro club! ¿Puede ayudarnos a construir nuestras últimas ideas?

(Página 5)

club

coche

(Página 6)

“clic”

(Página 14)

gire modelo

(Página 29)

Buen trabajo construyendo la casa de club.
¡Ahora, podemos añadir un columpio de rueda!

(Página 30)

Vamos a añadir un ascensor a la casa de club.
Con el uso de una polea y la palanca, podemos hacer que sea más fácil para el ascensor para subir y bajar.

(Página 32)

Debemos añadir un “zipline” a la casa de club.
¿Sabías que cuando usted baja por el “zipline” su energía almacenada o potencial, se convierte en energía cinética? La energía cinética es la energía del movimiento.

(Página 34)

¡La creación de este modelo de coche me dio una idea fantástica! ¿Puedes ayudarme a construir un coche que Audrey y yo puedo manejar?

(Página 39)

¡Construimos la casa de club! Ahora agarre su tarjeta de Mighty Makers® a empezar a trabajar en su primera invención.

(Página 40)

Modelos alternativos

máquina de animación

aleteo de pájaro

batidor de huevo

máquina de ilusión óptica

Ya que las instrucciones de los estos modelos van a www.knex.com/instructions y entre en el código **43753**.

ventilador

carretilla

caña de pescar

poste de bandera

bicicleta

(Página 41)

Inventión: Máquina de animación

(Página 46)

¡Ir a www.knex.com/downloadables y escriba **43753** para imprimir paneles gráficos!

(Página 47)

Inventión: Aleteo de Pájaro

(Página 55)

Inventión: Batidor de Huevo

(Página 58)

¡Nos encanta su construye! ¡Usted es un increíble inventor!

(Página 59)

Inventión: Máquina de Ilusión Óptica

(Tarjeta Mighty Makers®)

¡Hacerla girar!

El trompo quiere permanecer en posición vertical y equilibrada para que se pueda mover con menos energía - la resistencia al caer se llama inercia.

(DE) (Seite 3)

Treffen sie Emily und Audrey

Emilys Lieblingssachen!

Audreys Lieblingssachen!

**Lernen sie über...

#Erfinden

(Seite 4)

Wir wollen neue Erfindungen in unserem Clubhaus entwickeln! Können Sie uns bei der Herstellung unserer neuen Ideen helfen?

(Seite 5)

klubhaus

auto

(Seite 6)

“klicken”

(Seite 14)

drehe das modell

(Seite 29)

Tolle Arbeit beim Bauen des Klubhauses. Jetzt können wir noch eine Reifenschaukel anbringen!

(Seite 30)

Lassen Sie uns noch einen Aufzug zum Clubhaus einbauen. Durch die Verwendung einer Riemenscheibe und Hebel, können wir den Aufzugsehrn einfach von oben nach unten bewegen.

(Seite 32)

Wir sollten auch eine Zipline am Klubhaus anbringen. Wussten Sie, dass wenn Sie die Zipline herunterrollen, sich Ihre gespeicherte oder potentielle Energie, in kinetische Energie umgewandelt wird? Die kinetische Energie ist die Energie der Bewegung.

(Seite 34)

Der Bau dieses Modell Auto's gab mir eine fantastische Idee! Kannst Du mir helfen ein Auto zu bauen, in dem Audrey und ich fahren können?

(Seite 39)

Wir bauen das Klubhaus! Nun greifen Sie sich Ihre Mighty Makers® karte um mit Ihrer ersten Erfindung anzufangen.

(Seite 40)

Alternative Modelle

animations maschine

flutternder vogel

schneebesen

optische täuschung maschine

Für Anweisungen dieser Modelle gehen sie zu www.knex.com/instructions und geben sie Code **43753** ein.

lüfter

schubkarre

angelrute

fahnenmast

fahrrad

(Seite 41)

Erfindung: Animations Maschine

(Seite 46)

Gehe zu www.knex.com/downloadables und gebe **43753** ein um die Graphiken zu drucken!

(Seite 47)

Erfindung: Flatternder Vogel

(Seite 55)

Erfindung: Schneebesen

(Seite 58)

Wir lieben Ihre Bauten! Sie sind ein wunderbare Erfinder!

(Seite 59)

Erfindung: Optische Täuschung Maschine

(Karte Mighty Makers®)

Bringe es zum Drehen!

Der Kreisel will aufrecht und balanciert bleiben, so das ser sich mit möglichst wenig Energie bewegt – dieser Widerstand gegen das Umfallen heist Trägheit.

(IT) (Pagina 3)

Conosci Emily e Audrey

Cose preferite di Emily!

Cose preferite di Audrey!

**Imparavi...#Inventing

(Pagina 4)

Ci piace di progettare nuove invenzioni nel nostro clubhouse! Puoi aiutarci a costruire le nostre ultime idee?

(Pagina 5)

clubhouse

auto

(Pagina 6)

“clic”

(Pagina 14)

gira il modello

(Pagina 29)

Ottimo lavoro a costruire il clubhouse. Ora possiamo aggiungere l'altalena con ruota!

(Pagina 30)

Aggiunciamo un ascensore al clubhouse. Usando la puleggia e leva, possiamo rendere più facile per l'ascensore di andare su e giù.

(Pagina 32)

Doviamo anche aggiungere una teleferica al clubhouse. Sai che quando usi la teleferica, l'energia conservata o potenziale, si trasforma a energia cinetica? Energia cinetica è l'energia di movimento.

(Pagina 34)

La creazione di questo modello mi ha dato una fantastica idea! Mi puoi aiutare a costruire un'auto che lo e Audrey possiamo guidare?

(Pagina 39)

Abbiamo costruito il clubhouse! Adesso prendi la tua carta di Mighty Makers® per cominciare la prima invenzione.

(Pagina 40)

Modelli Alternativi

macchina per animazione

uccello che sbatte

sbattiuova

macchina d'illusione ottica

Per istruzioni di questi modelli vai a

www.knex.com/instructions e' inserire il codice **43753**.

ventilatore

carriola

canna da pesca

asta portabandiera

bicicletta

(Pagina 41)

Invention: Macchina per Animazione

(Pagina 46)

Vai a www.knex.com/downloadables e inserire **43753** per stampare carte grafici!

(Pagina 47)

Invention: Uccello che Sbatte

(Pagina 55)

Invention: Sbattiuova

(Pagina 58)

Chi piace il vostro costruzione! Lei è un incredibile inventore!

(Pagina 59)

Invention: Macchina D'illusione Ottica

(Carta Mighty Makers®)

Farlo girare!

La trottola vuole stare in piedi e bilanciata così si può muoversi usando menu energia – questa resistenza di non cadere is chiama inerzia.

(PT) (Página 3)

Reunir-se Emily e Audrey

Emilys coisas favoritas!

Audreys coisas favoritas!

**Aprender sobre...#Inventar

(Página 4)

Que gostaria de projetar novas invenções do nosso clube! Você pode ajudar-nos a construir as nossas ideias?

(Página 5)

clubhouse

carro

(Página 6)

“clique”

(Página 14)

gire modelo

(Página 29)

Grande trabalho construindo o clube. Agora, podemos acrescentar um pneu swing!

(Página 30)

Vamos adicionar um elevador para o clube. Usando uma polia e a alavanca, que pode tornar mais fácil para o elevador para ir para cima e para baixo.

(Página 32)

Devemos acrescentar também uma tirolesa para o clube. Você sabia que quando você zip para baixo da linha, sua memorizada, ou energia potencial, é transformada em energia cinética? Energia cinética é a energia do movimento.

(Página 34)

Criar este modelo de carro deu-me uma ideia fantástica! Você pode me ajuda a construir um carro que Audrey e eu posso dirigir?

(Página 39)

Criamos o clube! Agora pegue o seu Mighty Makers® cartão para começar a sua primeira invenção.

(Página 40)

Modelos Alternativos

animação máquina

pássaro batendo

ovo batedor

ilusão de óptica máquina

Para obter instruções destes modelos vá em www.knex.com/instructions e digite o código **43753**.

ventilador

carrinho de mão

cana de pesca

pólo de bandeira

bicicletas

(Página 41)

Invention: Animação Máquina

(Página 46)

Vá para www.knex.com/downloadables e entrar **43753** para imprimir painéis gráficos!

(Página 47)

Invention: Pássaro Batendo

(Página 55)

Invention: Ovo Batedor

(Página 58)

Nós adoramos a sua cria! Você é um fantástico inventor!

(Página 59)

Invention: Ilusão de Óptica Máquina

(Cartão Mighty Makers®)

A spin!

A spinning top quer permanecer na posição vertical e equilibrado de forma que possa se mover com menor consumo de energia - essa resistência à queda é chamada inércia.

(NL) (Bladzijde 3)

Ontmoet Emily en Audrey

Emily's favoriete dingen!

Audreys favoriete dingen!

**Leer over...#Uitvinden

(Bladzijde 4)

We willen nieuwe uitvindingen in ons clubhuis! U kunt meewerken aan onze nieuwste ideeën?

(Bladzijde 5)

clubhuis

auto

(Bladzijde 6)

“klik”

(Bladzijde 14)

draai model

(Bladzijde 29)

Grote gebouw het clubhuis. We kunnen nu een band swingen!

(Bladzijde 30)

Voegen we een lift naar het clubhuis. Door met een poelie en hendel, wij maken het gemakkelijker voor de lift naar boven en naar beneden.

(Bladzijde 32)

Wij moeten ook nog een zipline naar het clubhuis. Wist u dat wanneer u zip-down the line, uw opgeslagen, of potentiële energie wordt omgezet in kinetische energie? De kinetische energie is de energie van beweging.

(Bladzijde 34)

Het maken van dit model auto gaf me een fantastisch idee! Kunt u me helpen bouwen aan een auto dat Audrey en IK kan rijden?

(Bladzijde 39)

We bouwen het clubhuis! Nu pak je Mighty Makers® kaart om aan de slag te gaan met uw eerste uitvinding.

(Bladzijde 40)

Alternatieve Modellen

animatie machine

fladderende vogel

eiwit klopper

optische illusie machine

Voor instructies van deze modellen naar www.knex.com/instructions en vul de code **43753**.

ventilator

kruiwagen

hengel

vlag pole

fiets

(Bladzijde 41)

Invention: Animatie Machine

(Bladzijde 46)

Ga naar www.knex.com/downloadables en voer **43753** printen grafische panelen!

(Bladzijde 47)

Invention: Fladderende Vogel

(Bladzijde 55)

Invention: Eiwit Klopper

(Bladzijde 58)

We love u bouw! U bent een geweldige uitvinder!

(Bladzijde 59)

Invention: Optische Illusie Machine

(Mighty Makers® Kaart)

Het spin!

De botsauto wil rechtop en evenwichtige dus het kan verplaatsen met minder energie - deze weerstand naar beneden valt is inertie genoemd.



Inventor's Clubhouse

building set

Clubhouse de L'inventeur

jeu de construction



Sold separately.

Vendus séparément.

Se venden por separado.

Separat erhältlich.

Venduti separatamente.

Vendidos separadamente.

Afzonderlijk verkocht.



KNEX.COM

WARNING: CHOKING HAZARD – Small parts. Not for children under 3 years.
ATTENTION : RISQUE D'ÉTOUFFEMENT – Pièces de petite taille. Ne convient pas aux enfants de moins de 3 ans.
ADVERTENCIA: PELIGRO DE ASFIXIA – Piezas pequeñas. No para niños menores de 3 años.
ACHTUNG: ERSTICKUNGSGEFAHR – Kleinteile. Nicht geeignet für Kinder unter 3 Jahren.
AVVISO: PERICOLO DI SOFFOCARE – Pezzi piccoli. Non adatto per bambini sotto 3 anni.
AVISO: PERIGO DE SUFOCAÇÃO – Peças pequenas. Não se destina a crianças com menos de 3 anos de idade.
WAARSCHUWING: INSLIKKINGSGEVAAR – Kleine onderdelen. Niet geschikt voor kinderen jonger dan 3 jaar.

©2016 K'NEX Limited Partnership Group, P.O. Box 700, Hatfield, PA 19440-0700; 1-800-KID-KNEX (USA/Canada/États-Unis/EE.UU.); email@knex.com; knex.com. K'NEX UK Ltd., P.O. Box 3083, Reading RG1 9YQ, England.

K'NEX, Building Worlds Kids Love, Mighty Makers, and Building Big Ideas are registered trademarks of K'NEX Limited Partnership Group. Product & colors may vary. Most models can be built one at a time. For customers outside the USA/Canada please contact your local distributor at www.knex.com/distributors.

(FR) K'NEX, Building Worlds Kids Love, Mighty Makers, et Building Big Ideas sont des marques déposées de K'NEX Limited Partnership Group. Le produit et ses couleurs peuvent varier. Les différents modèles ne peuvent être construits qu'un par un. Pour les clients en dehors du Canada et des États-Unis, veuillez contacter votre distributeur local que vous pouvez trouver sur www.knex.com/distributors.

(ES) K'NEX, Building Worlds Kids Love, Mighty Makers, y Building Big Ideas son marcas registradas de K'NEX Limited Partnership Group. El producto y los colores pueden variar. La mayoría de los modelos se pueden construir uno a la vez. El cliente que no vive en EE.UU./Canadá se pone en contacto con el distribuidor local. Encuentre la información para el distribuidor local en www.knex.com/distributors.

7+

43753

143753-V1-04/16