

15135/63192

K'NEX

Loopin' Lizard

BALL MACHINE
MACHINE À BALLES

⚠ WARNING:

CHOKING HAZARD - Small parts.
Not for children under 3 years.

⚠ AVERTISSEMENT:

DANGER D'ÉTOUFFEMENT - Pièces de
petite taille. Ne pas donner aux enfants de
moins de 3ans.



OVER 3FT / PLUS DE 1M

Get more, See more, Do more!
Obtiens plus, Vois plus, Fais plus !



K'NEX.com

9+

Building System
Système de Construction

Important Stuff for Parents and Kids

Keep these instructions in a handy location. They contain important safety information.

Read all warnings and instructions before you start to build and operate the model.

WARNING: CHOKING HAZARD - Small parts. Not for Children under 3 years.

CAUTION: Keep hair, fingers, face, and clothing away from all moving parts.

Battery Information:

Caution: To Avoid Battery Leakage

- Be sure to insert the batteries correctly and always follow the toy and battery manufacturers' instructions.
- Do not mix old and new batteries or alkaline, standard (carbon-zinc) or rechargeable (nickel-cadmium) batteries. Only batteries of the same or equivalent type recommended should be used.
- Always remove weak or dead batteries from the product; do not short-circuit supply terminals.
- Insert batteries with correct polarity (+/-) as shown.

Important Tips

- Alkaline batteries AA (LR6) are recommended.
- Rechargeable batteries are not recommended.
- Remove rechargeable batteries from toy before charging; they must be charged only under adult supervision.
- Non-rechargeable batteries must not be recharged.
- Keep components free of dust; do not immerse or use in water.
- Do not dispose of batteries in a fire; they could leak or explode and cause injury.

- Remove all batteries if the toy will not be used for a long period of time.
- Do not put Rods smaller than 2 inches in any openings of the motor; they will damage the motor, and cannot be removed.

How to Insert and Remove Batteries:

- Use a small Phillips head screwdriver to loosen the screw. Insert 2 fresh AA batteries (LR6) into the compartment with the correct polarity (+/-) as shown here.

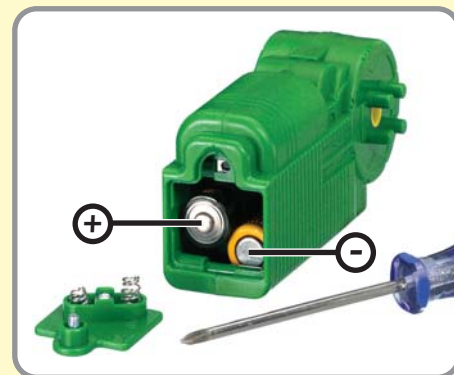

K'NEX Building Basics

Ready, Set, Build

To begin your model, find the **1** and follow the numbers. Each piece has its own shape and color. Just look at the pictures, find the pieces in your set that match and then connect them together.

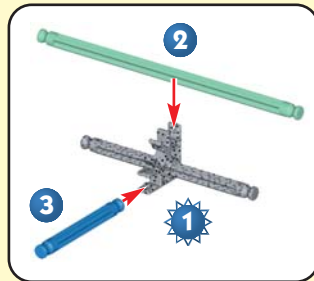

Movin' On

Faded colors show you this section is already built. You'll want to connect the new section to the place where the arrows are pointing. The new pieces you add and the place where they connect will be in full color.

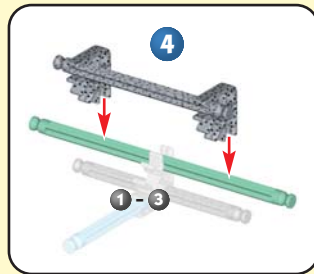

Spacers

There are places in your model where you need to add blue and silver Spacers. Be sure to use the right color and count them carefully.



Flexi-rods

A Flexi-rod is a Rod that you can bend to make curves. It will be easier to attach to your model if you bend it back and forth first.



Chain Links

Attach Chain Links in the same direction. Chain Links stretch over time; replace one link with a Chain Splice if needed.



Connectors

There are blue and silver Connectors with special long slots. They slide together as you see in the pictures. Push these parts together until you hear a "click".

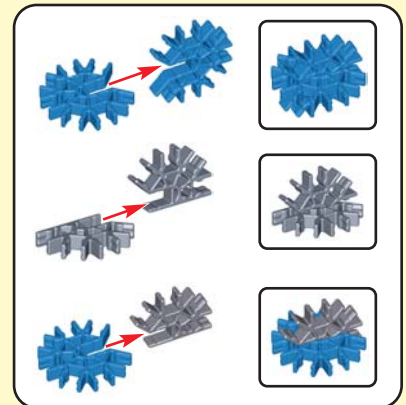

Splice

You may need to use a Splice piece on your Track.

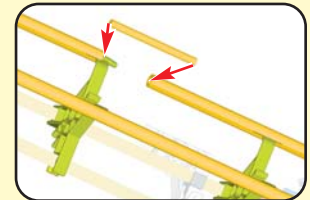

Try to face your model in the same direction as shown in the instructions while you build.

In order to see the parts more clearly, sometimes the view changes from page to page.

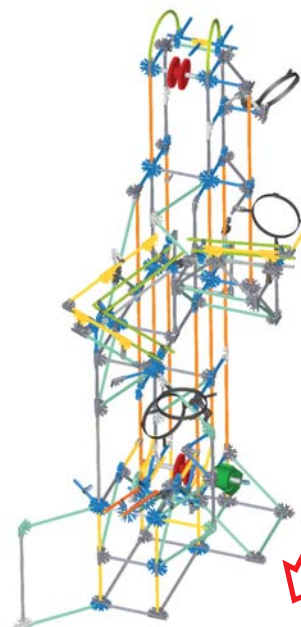

Tips & Troubleshooting

Building Tips:

- Important Tip: Do not bend the Clamps back and forth too much.
- Install batteries to test motor before building models.
- Build on a flat, level surface.
- Take your time to enjoy the building process.
- Share the K'NEX building experience with your child! K'NEX building can be fun for the whole family.
- If you need to move your model after it's built, two people can lift it carefully, making sure you are not unsnapping the connections.
- Product and colors may vary.
- Flexi-Tubes and Clamps may need adjustments when you're ready to turn on the model.
- Make sure the Ball Pick-Ups are built properly.
- Are the Chain Link pieces built correctly? Do you have the exact number of chain pieces for each model?
- Pay special attention to the placement and the number of Track Connectors and the spacing between them.

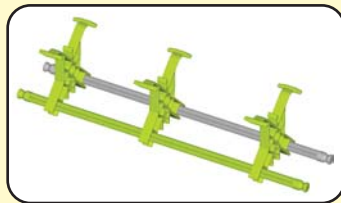

- Stretch out the green Flexi-Tubes fully before using.
- Standard, hard K'NEX balls from other K'NEX sets (or other balls) WILL NOT WORK.
- Watch how the Balls interact with the Flexi-Tubes and adjust where needed.
- Move the Flexi-Tubes side to side by turning or twisting either the Clamps or the K'NEX parts that hold the Clamps.
- Stretch or compress the Flexi-Tubes to help the Balls spiral through the Tubes.

Balls stuck in Tubes or falling off

- Check to see if your model is built correctly.
- Adjust Flexi-Tubes and make sure they are positioned with the Clamps as shown in the instructions.
- Watch the path of the Balls and twist or adjust the Flexi-Tubes so the Balls are not stuck.
- Adjustments to the position of the Flexi-Tubes will be necessary as you send the Balls through the model and watch the path of the Balls.
- Due to the complexity of the model, an occasional Ball will fall off. Place it back in the Ball Pick-Up and send it on its way again through the Loopin' Lizard.

Parts Count

Before you start building, be sure to compare the parts in your set with the parts listed below. If anything is missing, check out the back cover of this instructions booklet for how to contact us. We're here to help!

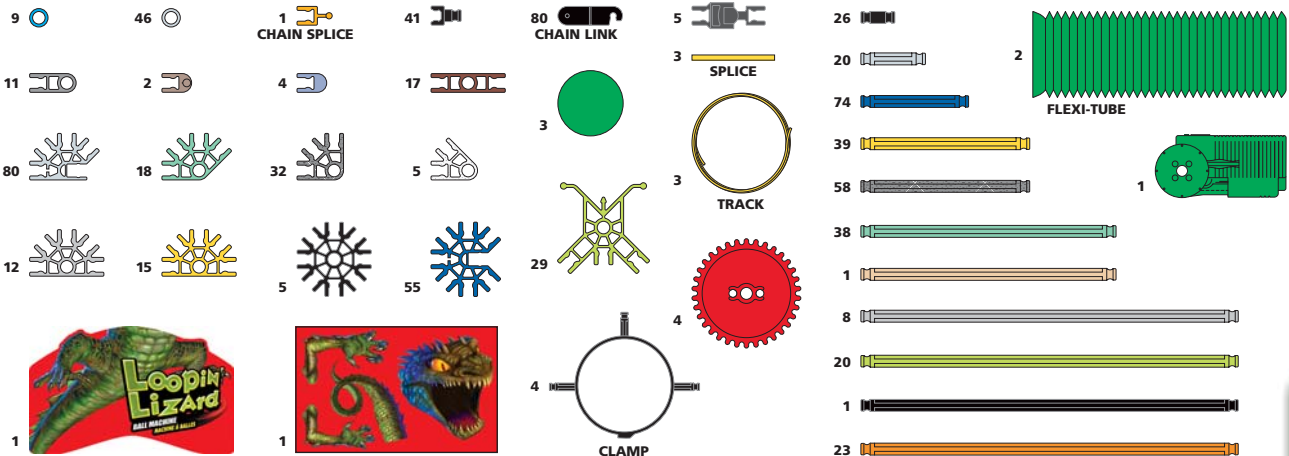

Loopin' Lizard

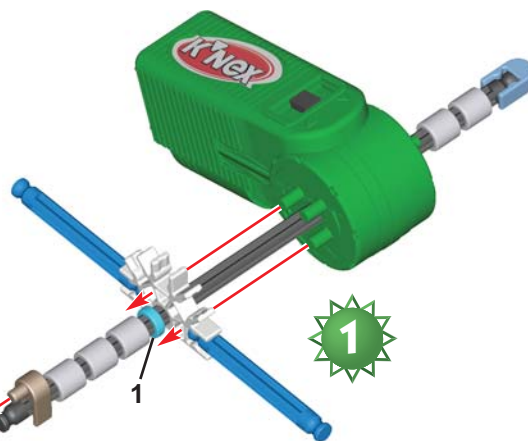

- ENG** Did you install 2 AA (or LR6) batteries?
- F** As-tu installé 2 piles AA (ou LR6)?
- E** ¿Instalaste 2 pilas AA (o LR6)?
- D** Hast du 2 Batterien der Baugröße AA (oder LR6) eingelegt?
- NL** Heb je er 2 AA (of LR6) batterijen ingestoken?

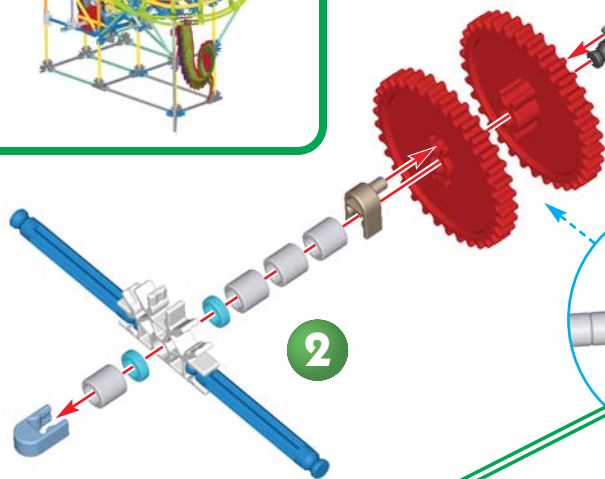

- ENG** Push Gears together tightly.
- F** Pousse bien les engrenages ensemble.
- E** Engancha firmemente los Engranajes.
- D** Achte darauf, dass das Getriebe fest verzahnt ist.
- NL** Duw de versnellingsmechanismen stevig in mekaar.

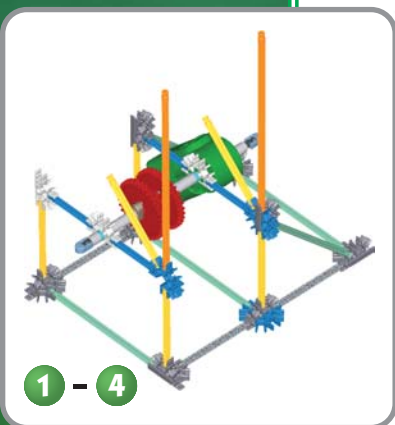
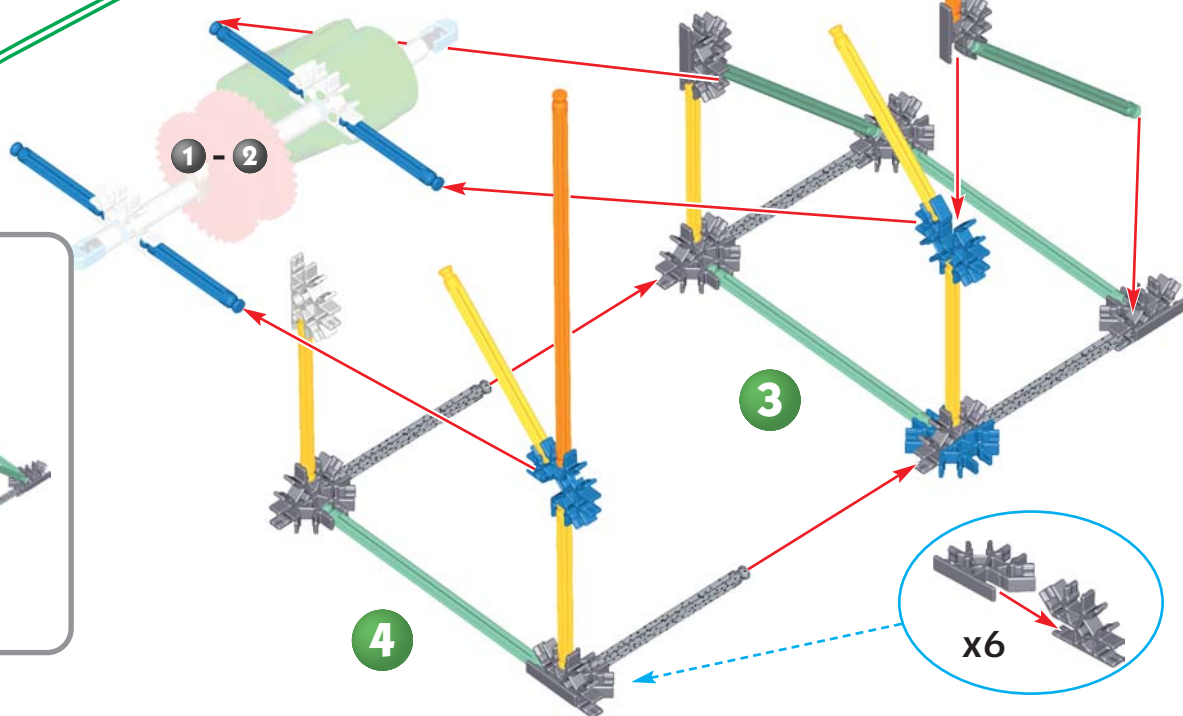

1 - 4

6

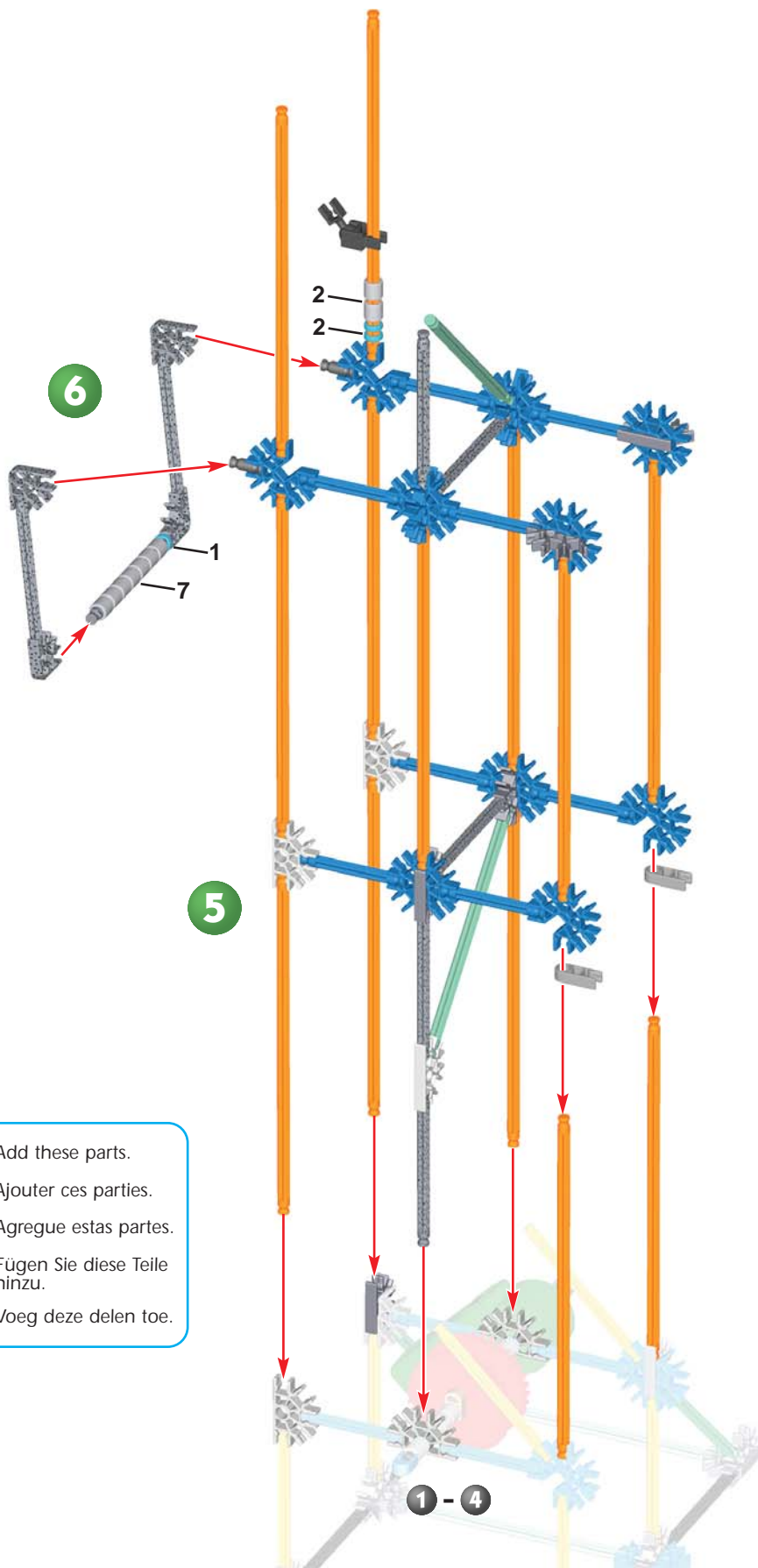

6

5

1 - 4

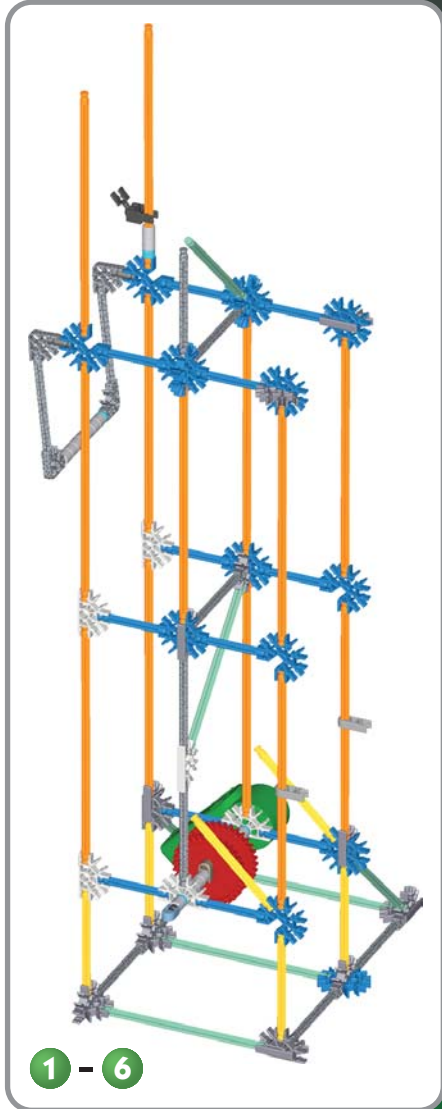

1 - 6



x11

- ENG** Add these parts.
- F** Ajouter ces parties.
- E** Agregue estas partes.
- D** Fügen Sie diese Teile hinzu.
- NL** Voeg deze delen toe.

7

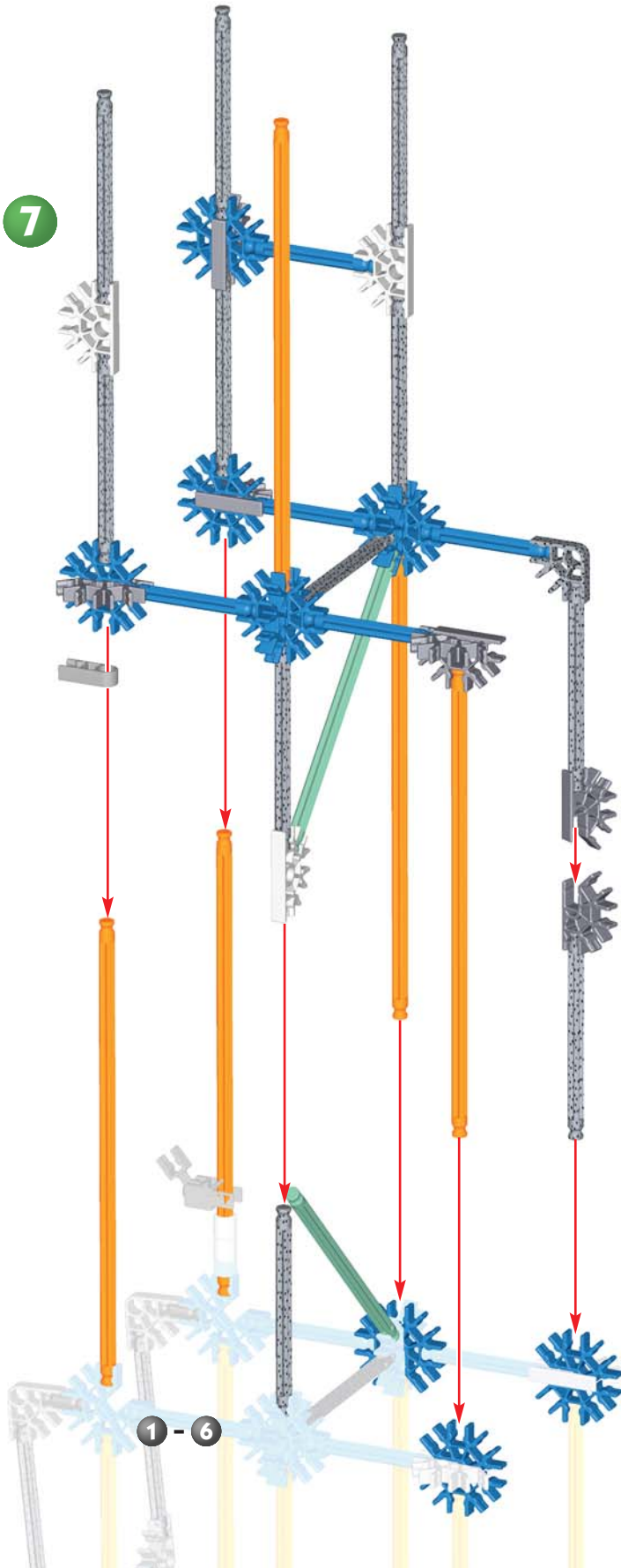

1 - 6

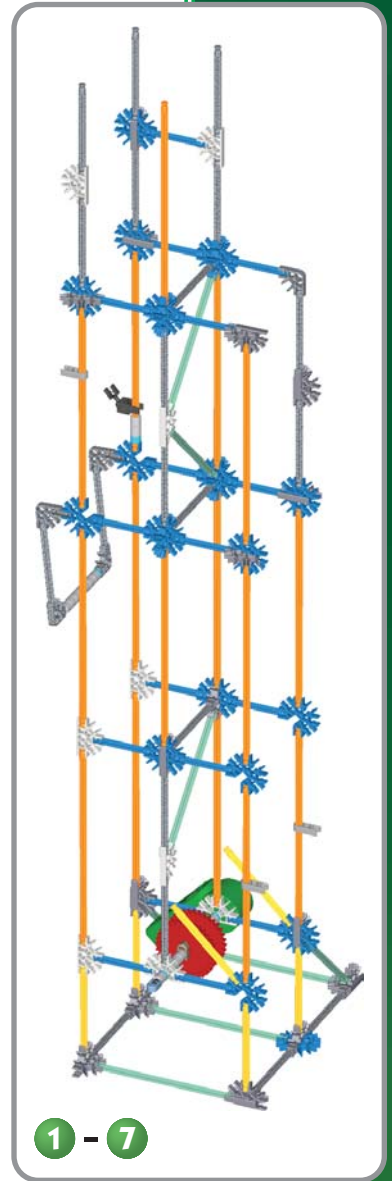

1 - 7

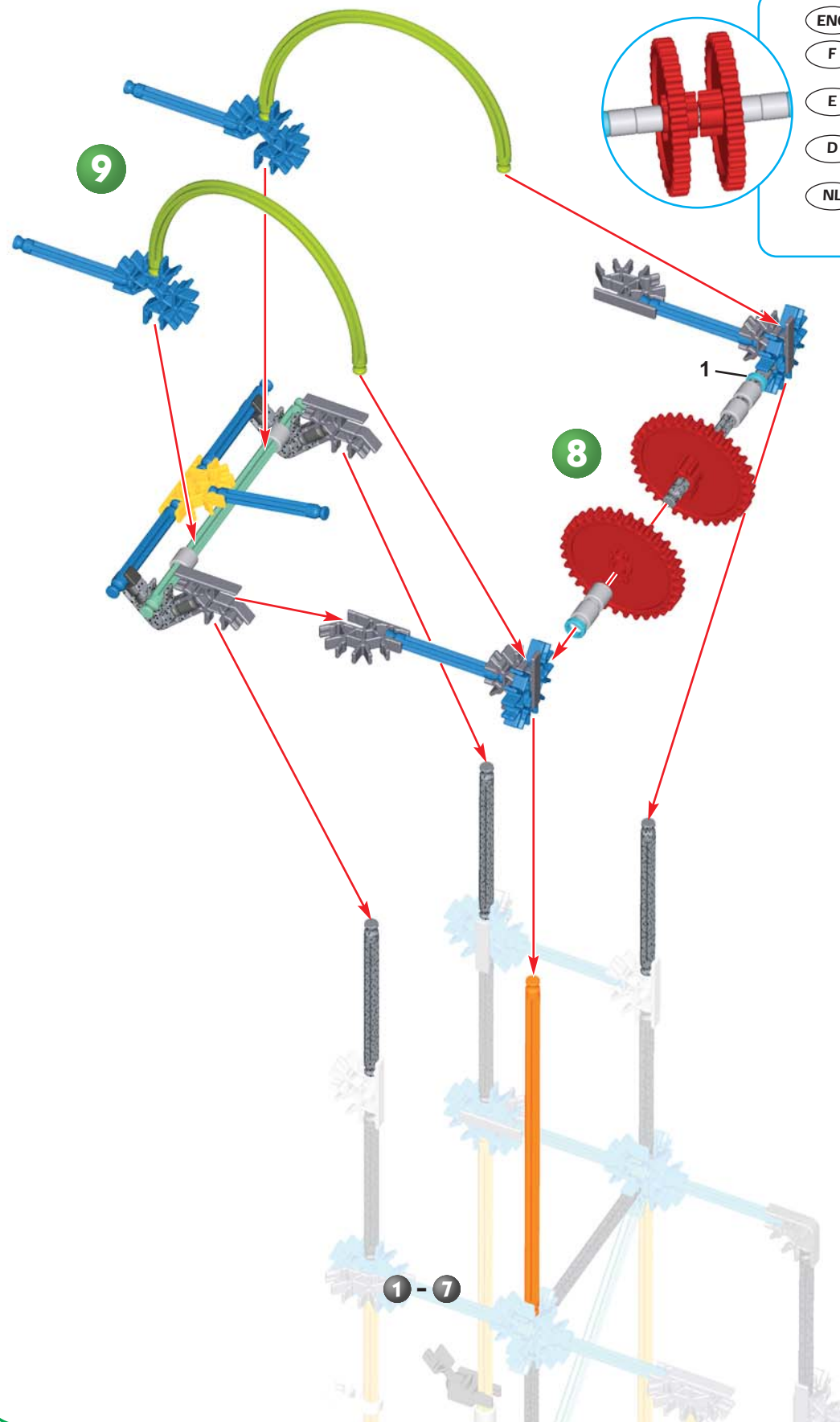

ENG Push Gears together tightly.

F Pousse bien les engrenages ensemble.

E Engancha firmemente los Engranajes.

D Achte darauf, dass das Getriebe fest verzahnt ist.

NL Duw de versnelling-smechanismen stevig in mekaar.

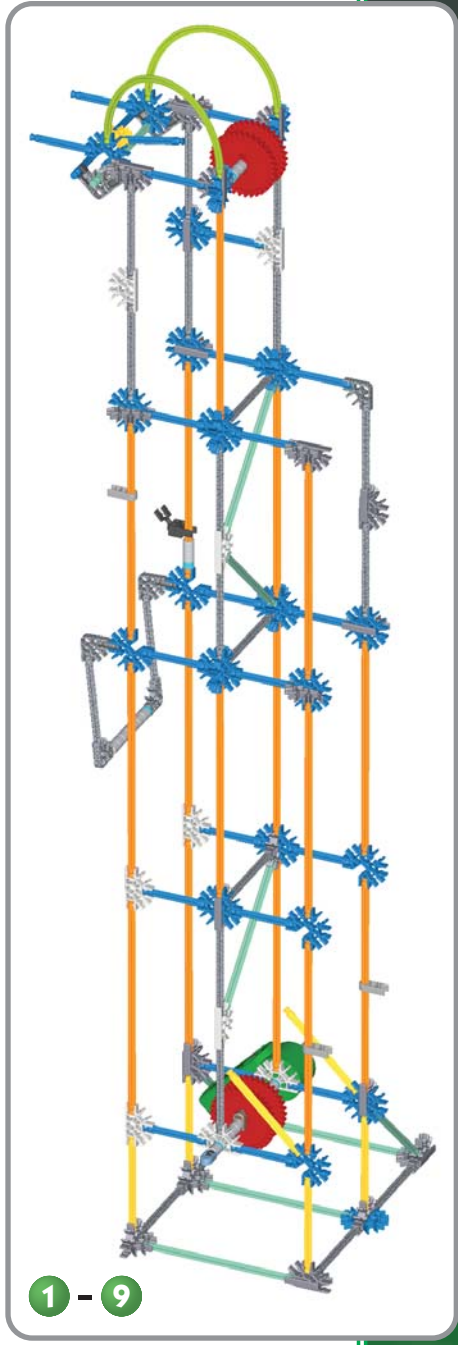

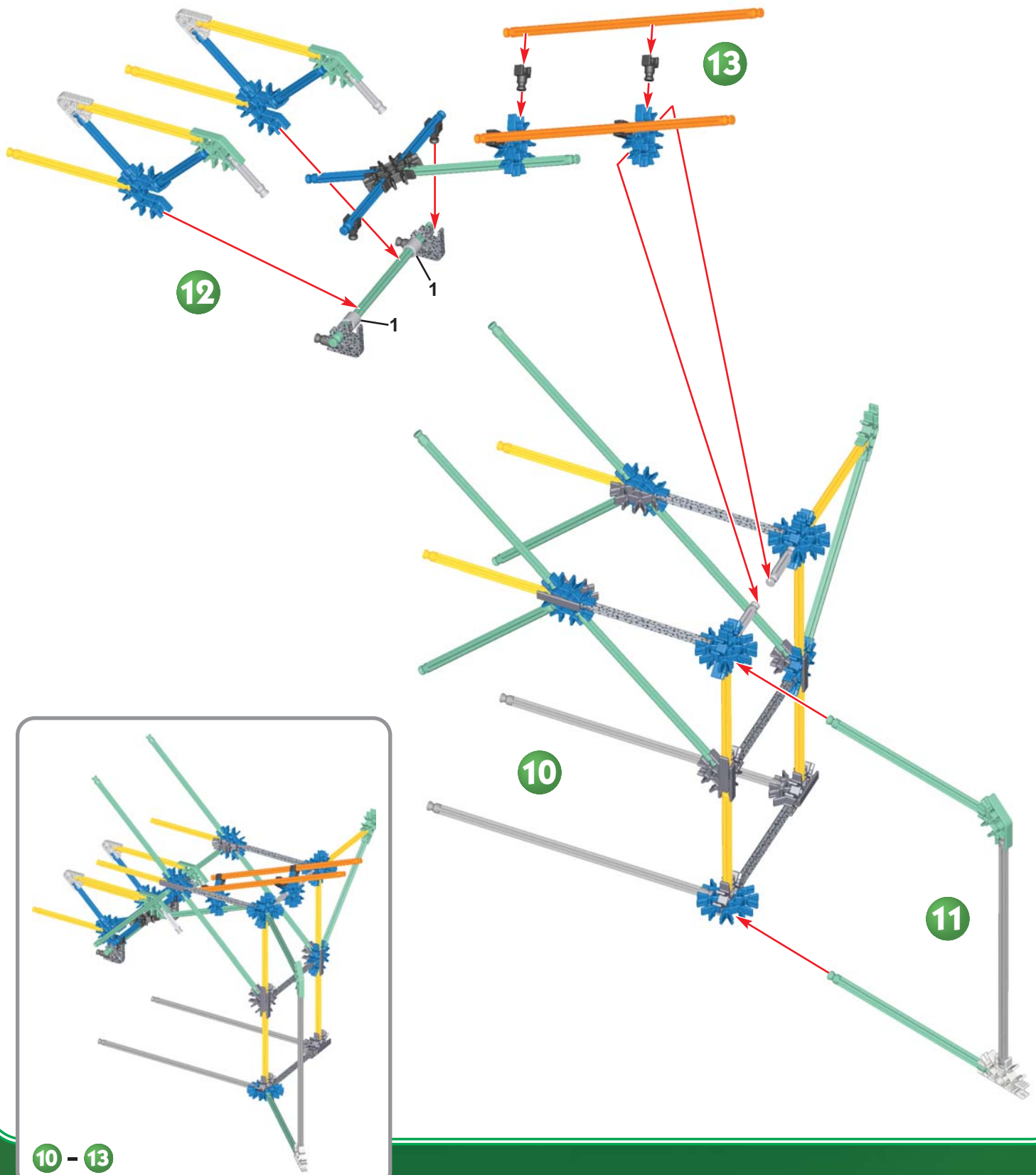

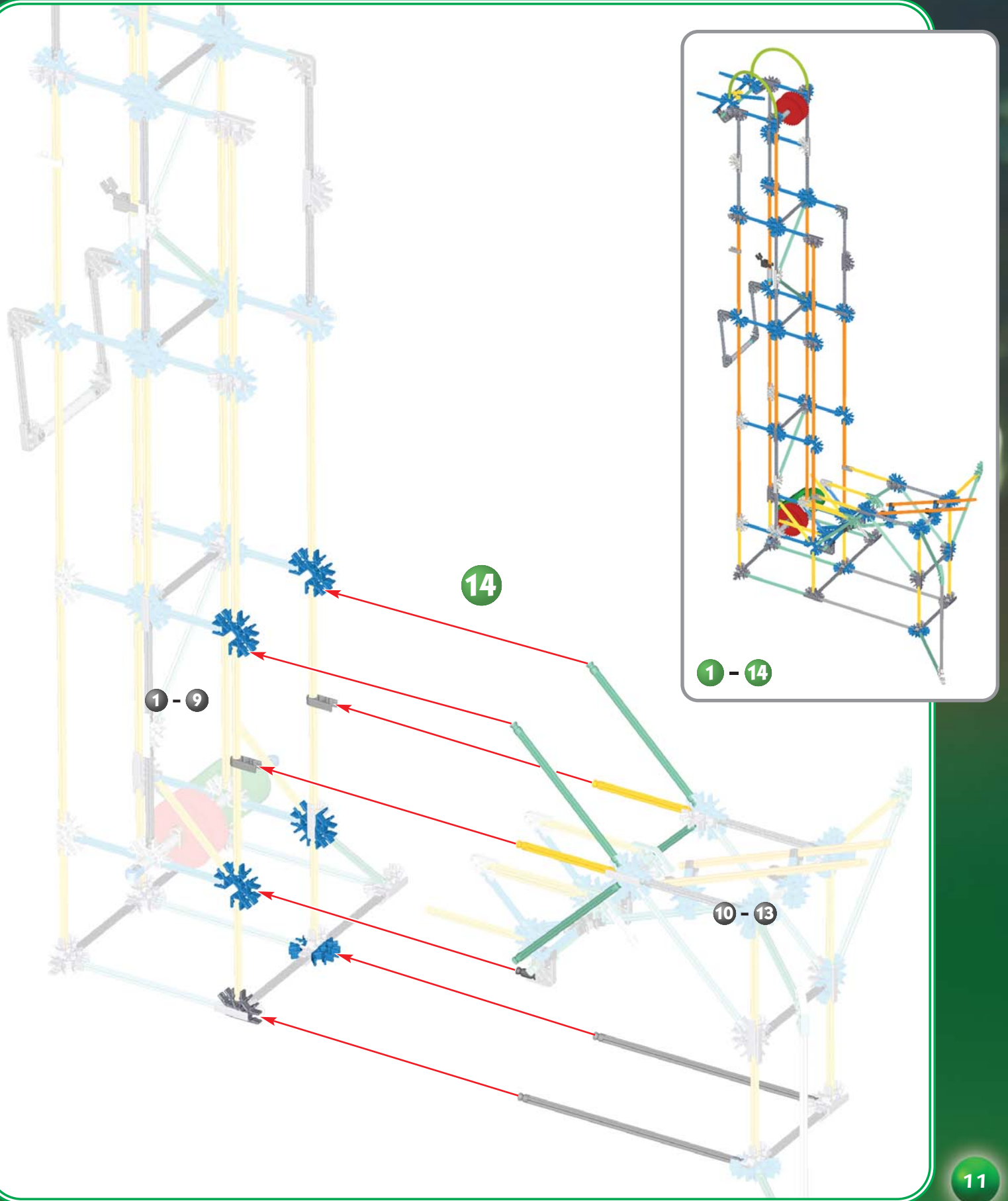

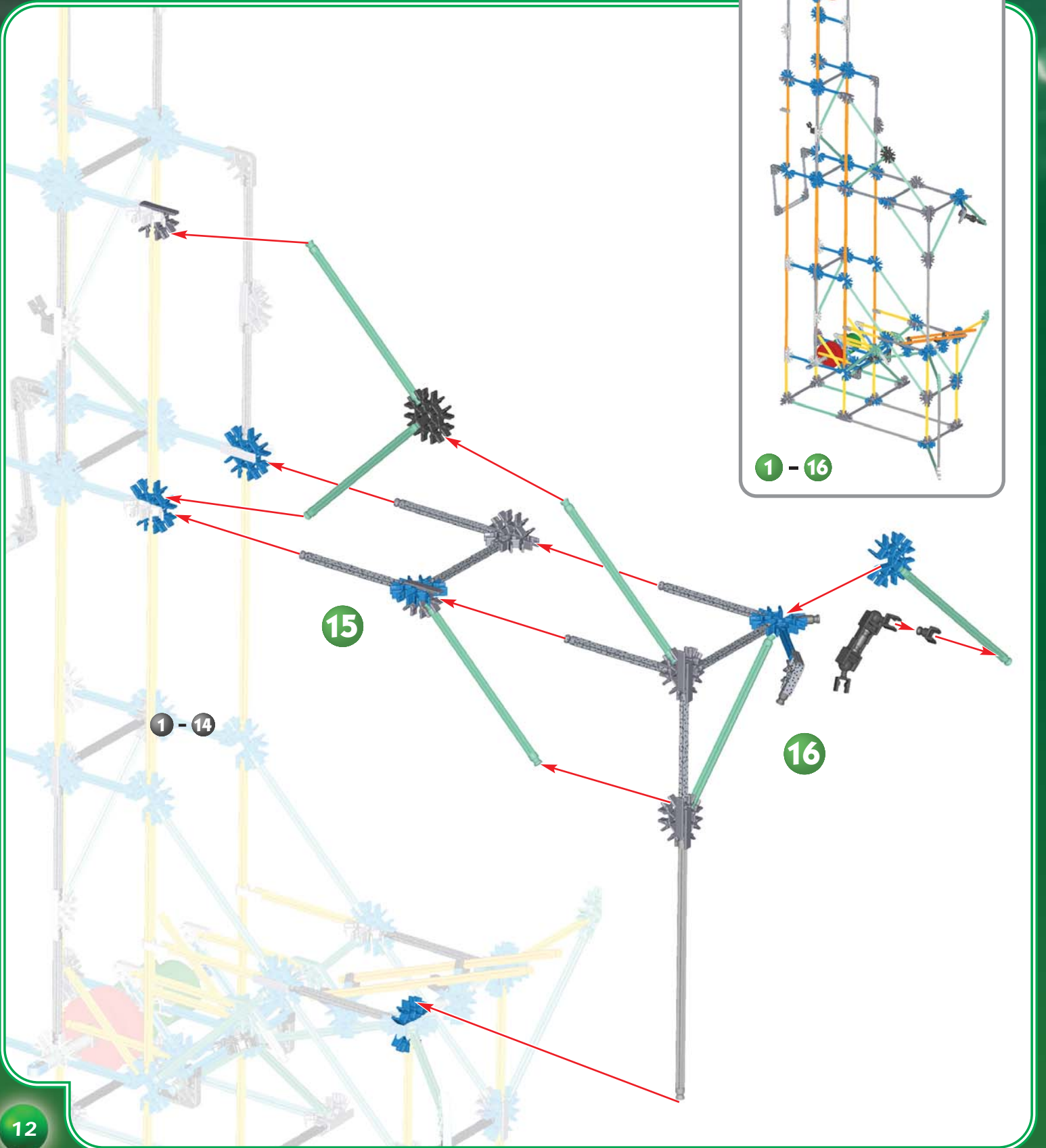

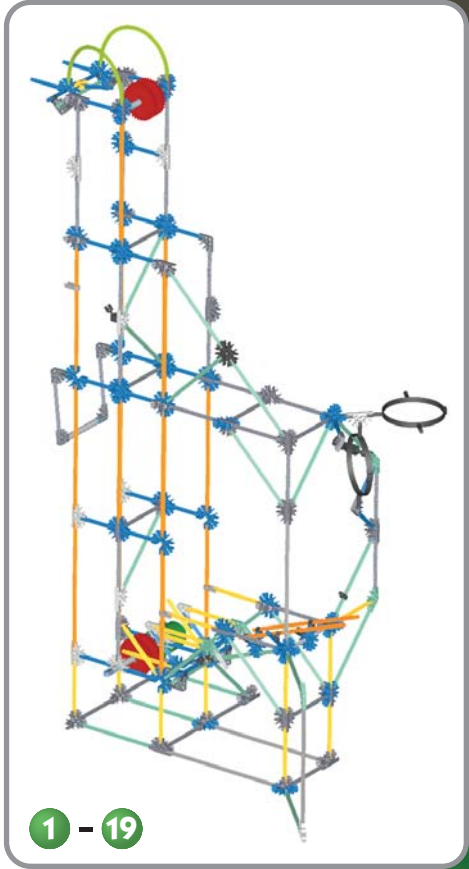
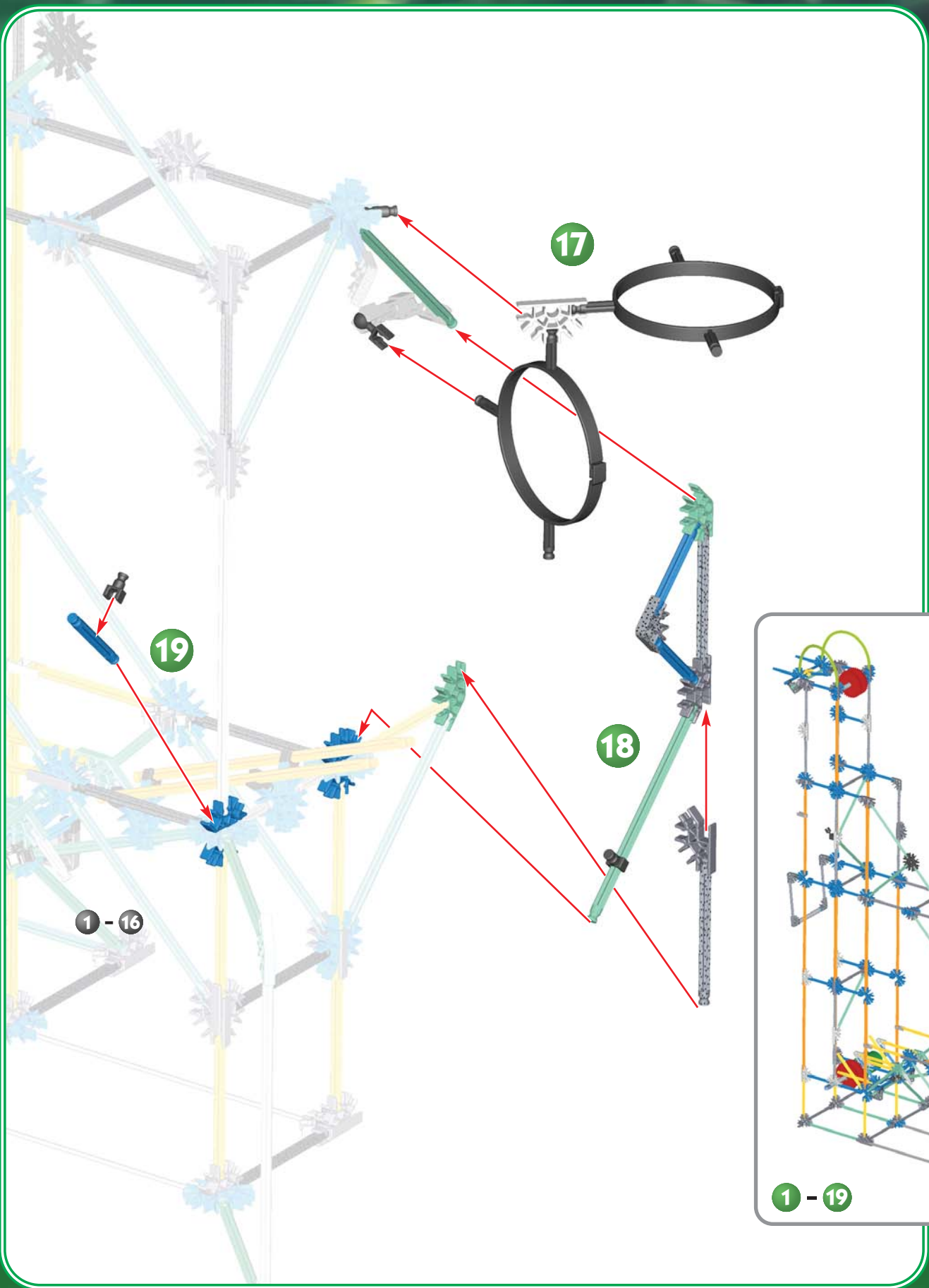

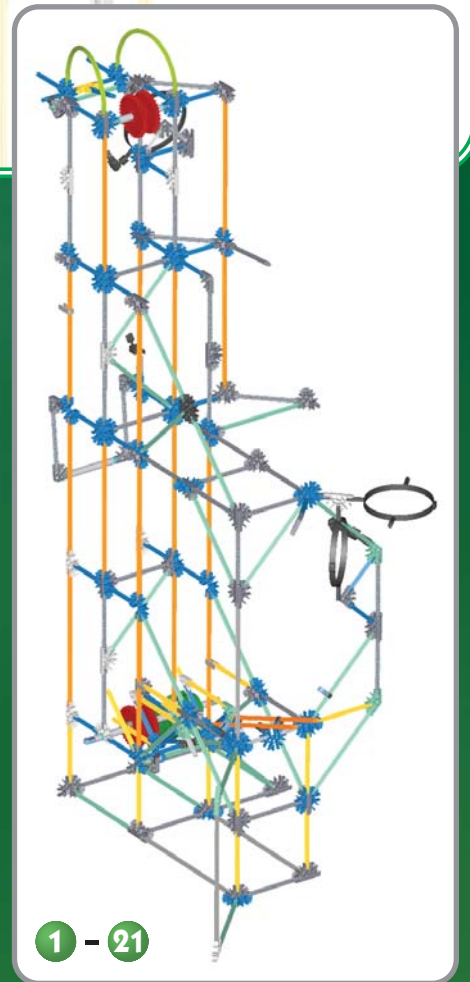
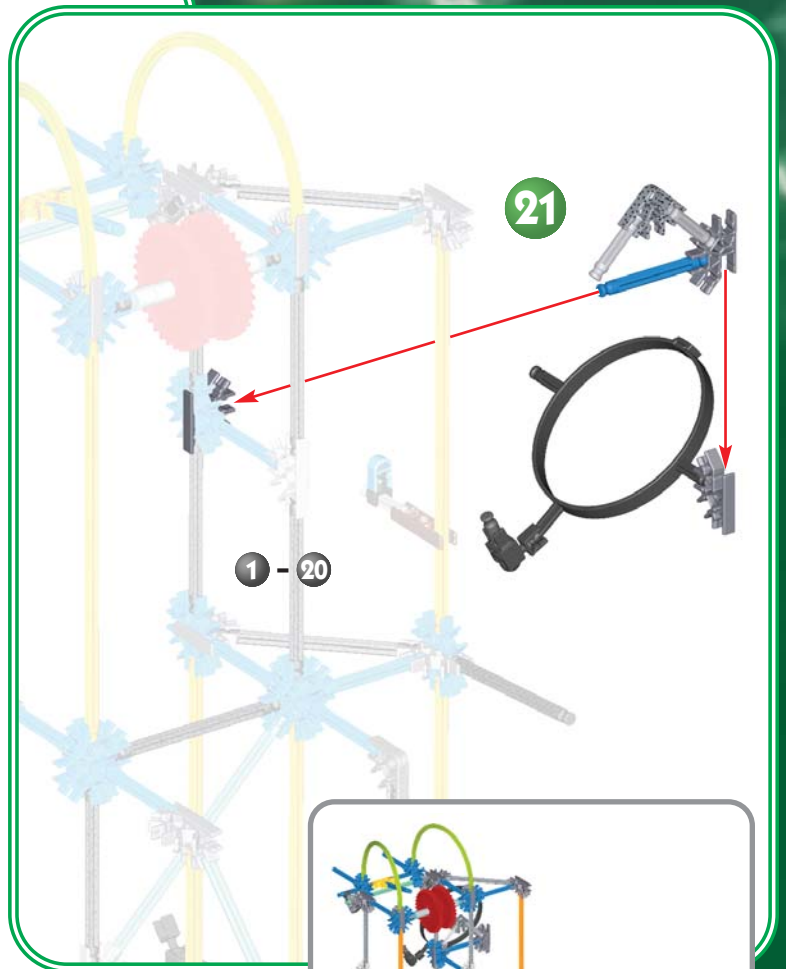
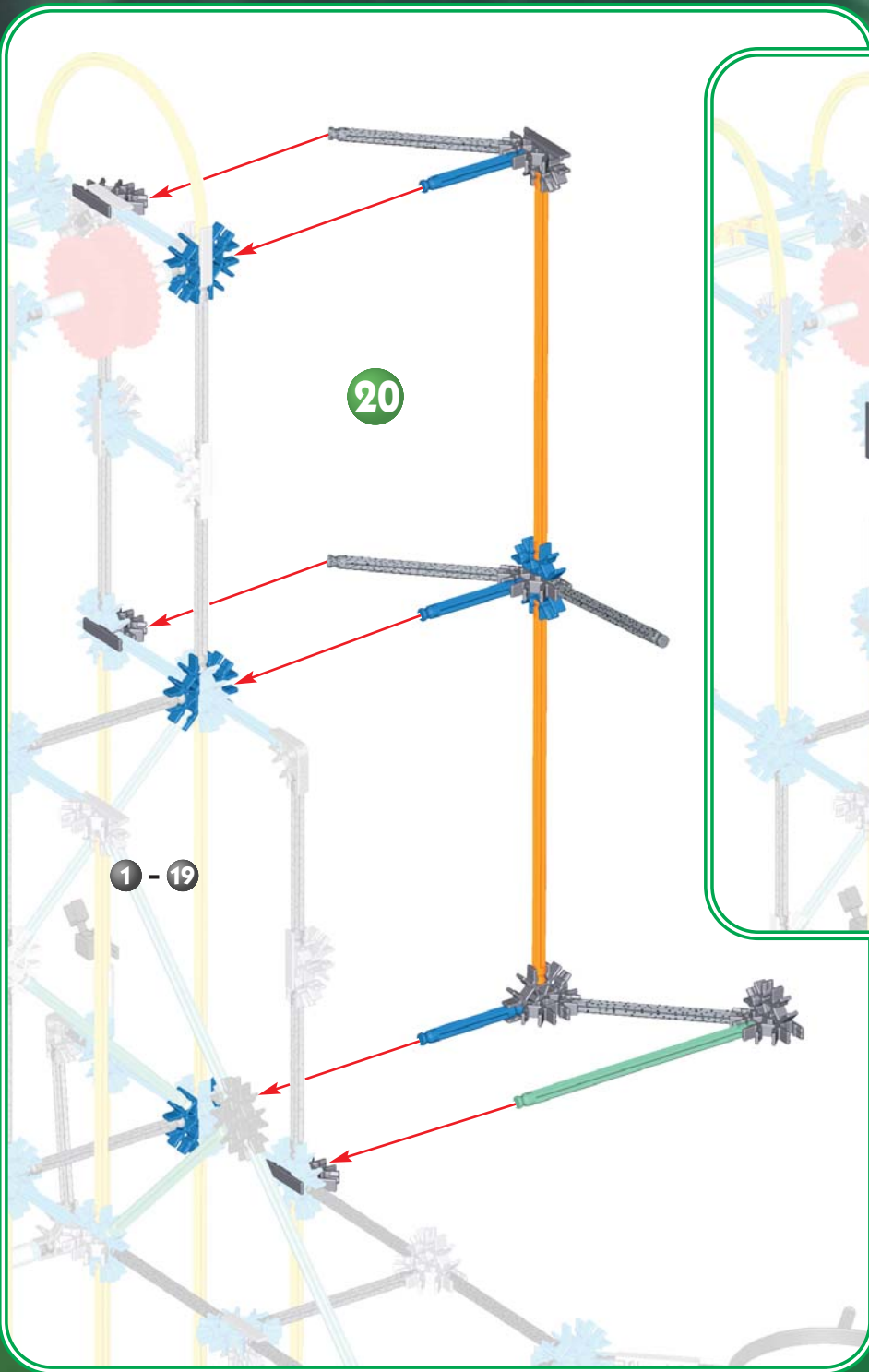

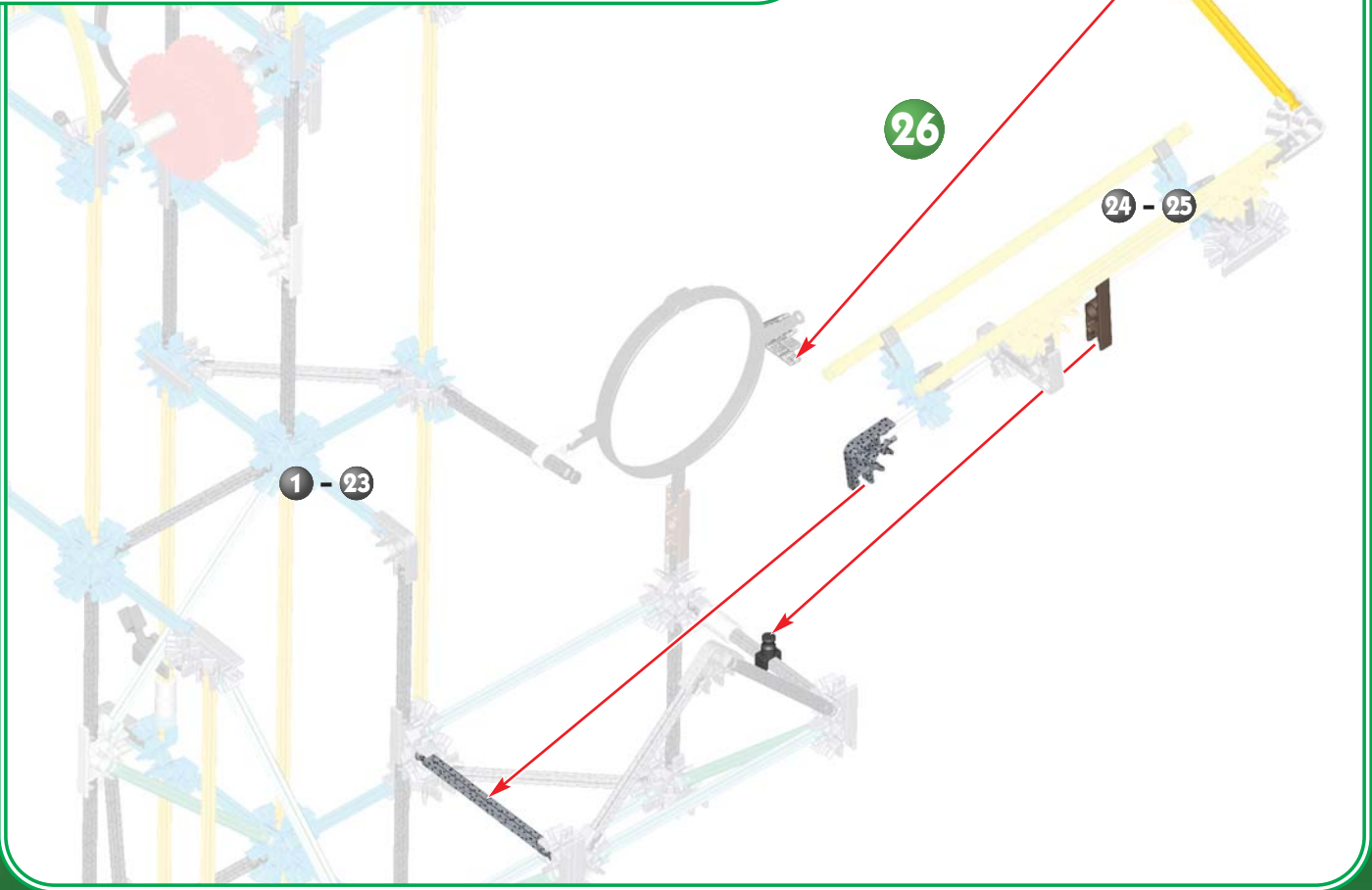
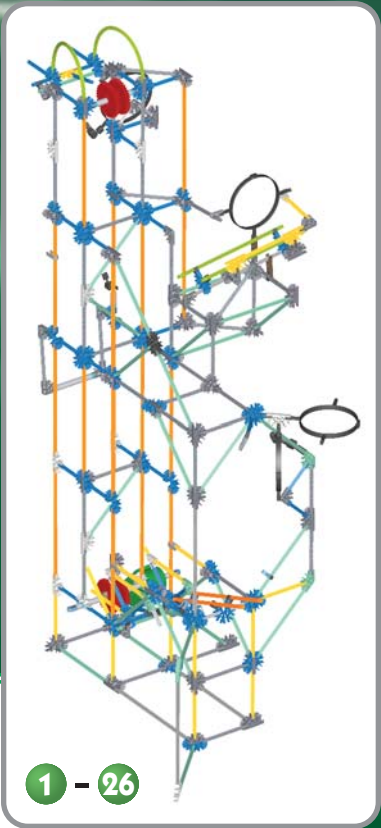
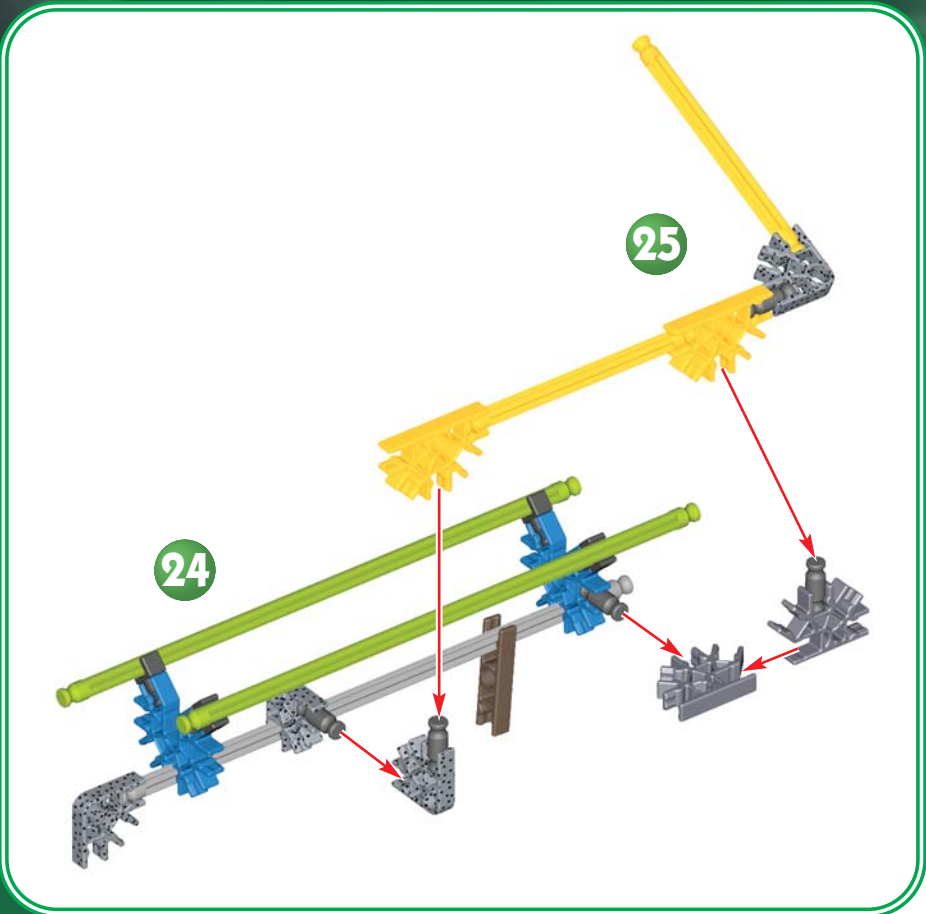

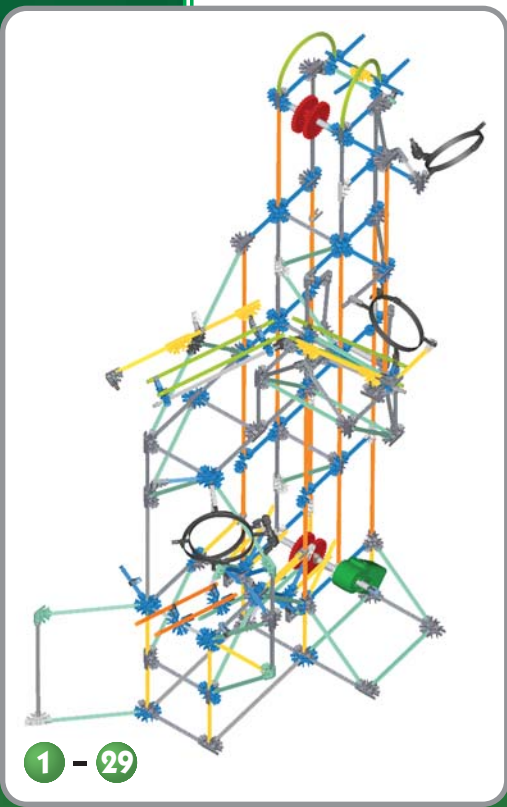
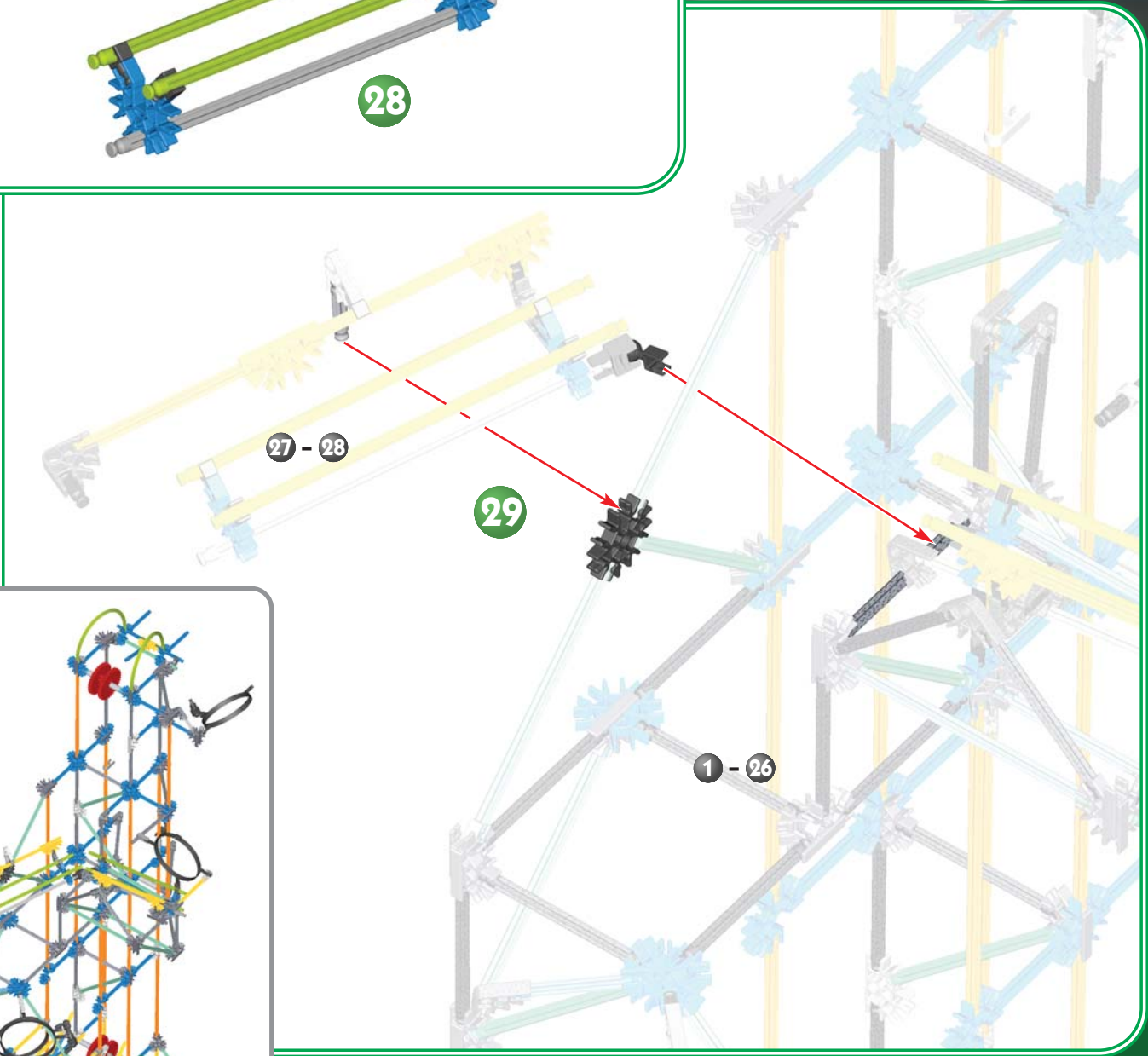
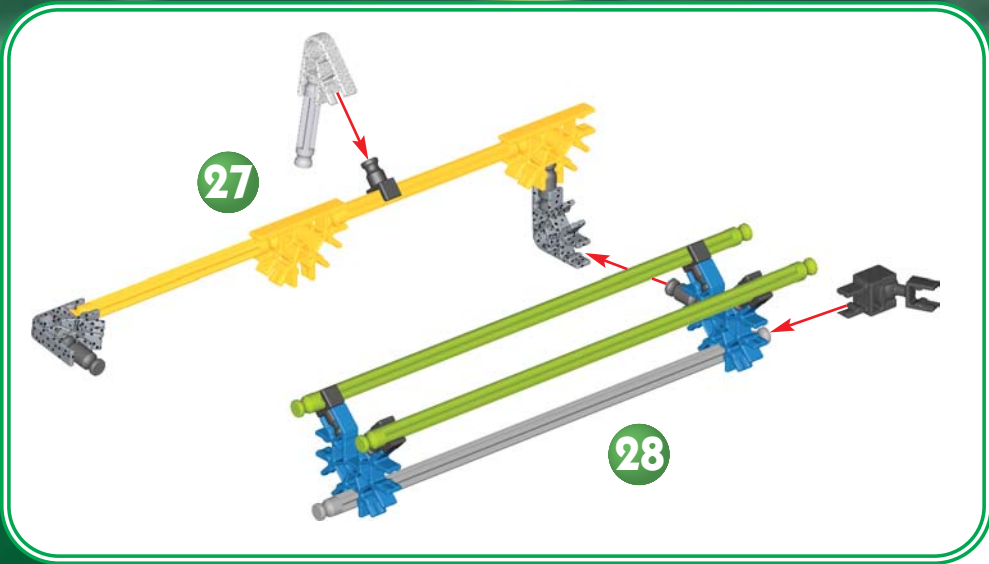

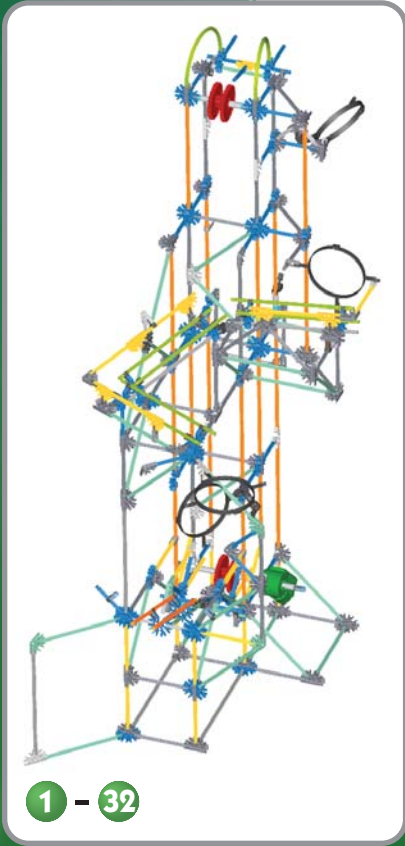
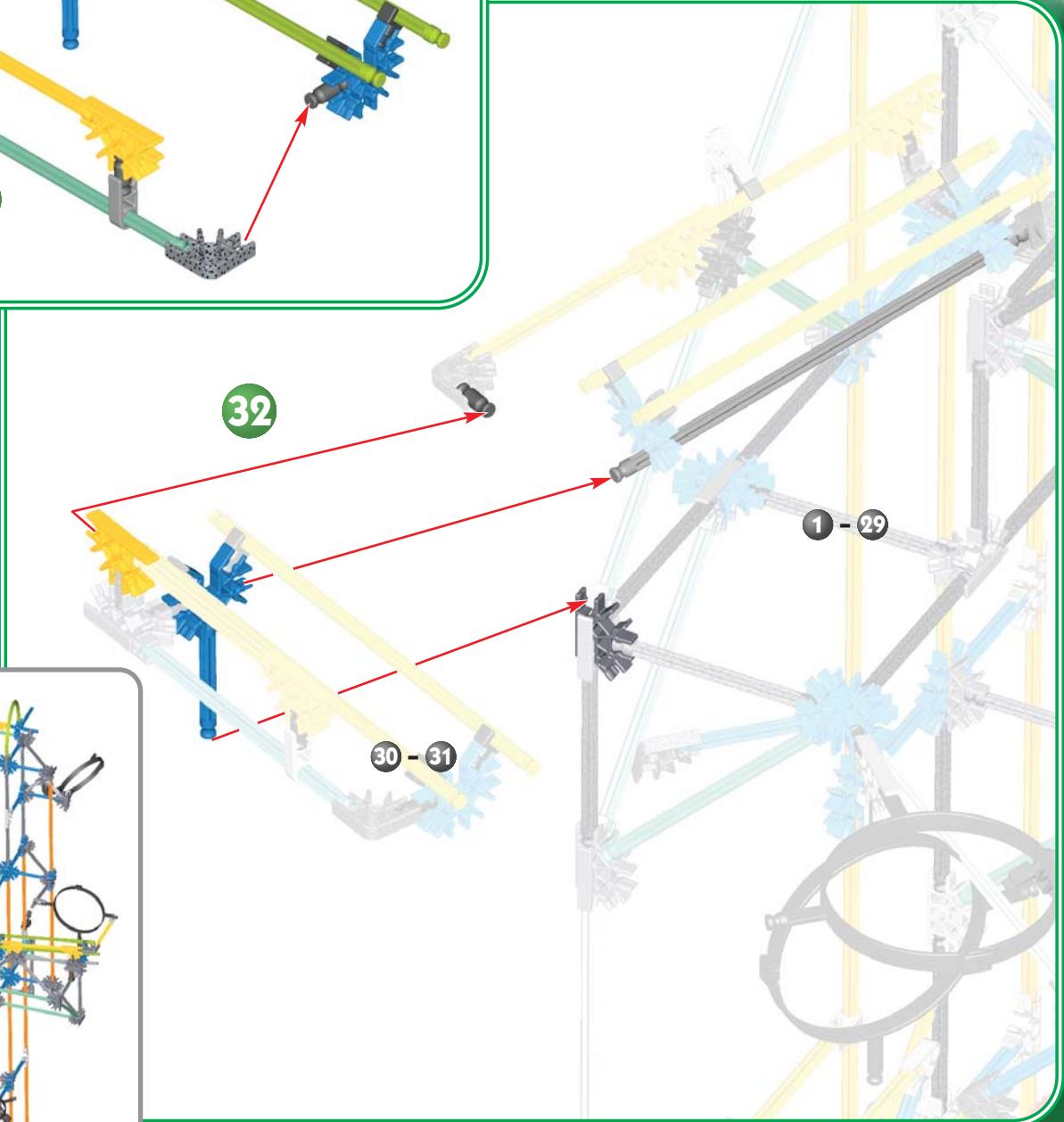
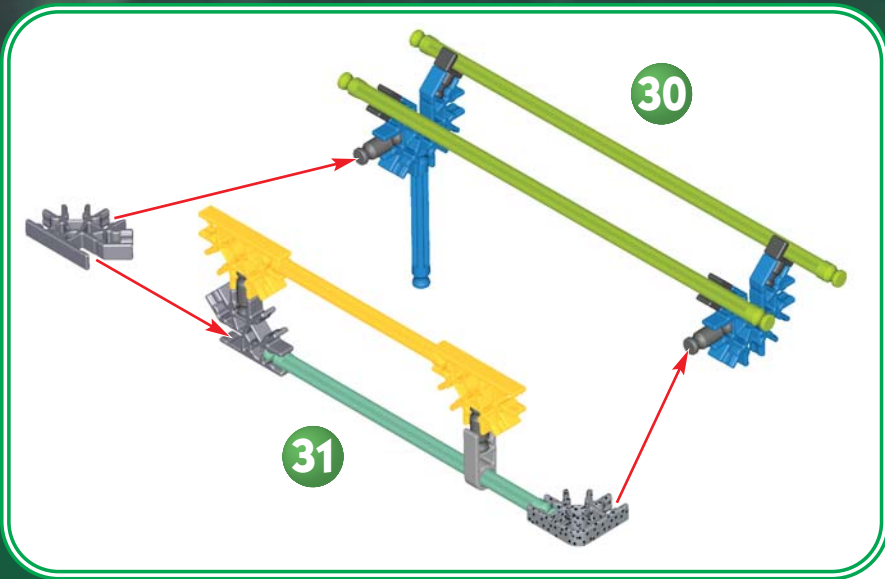

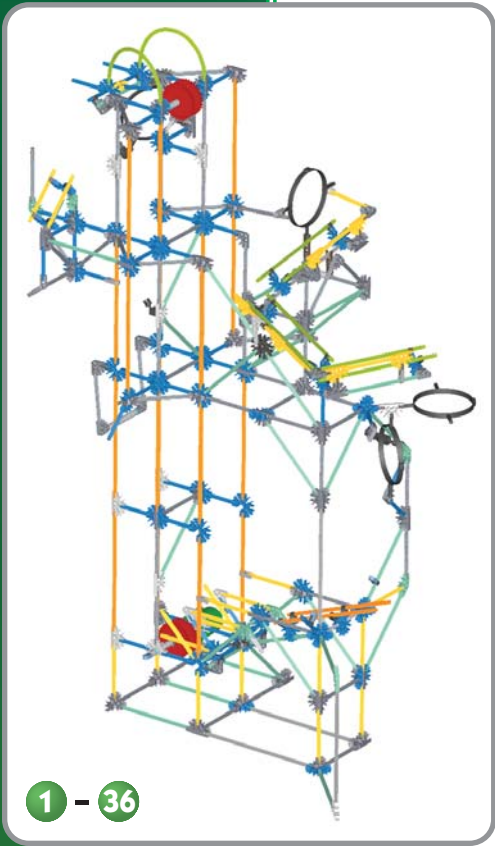
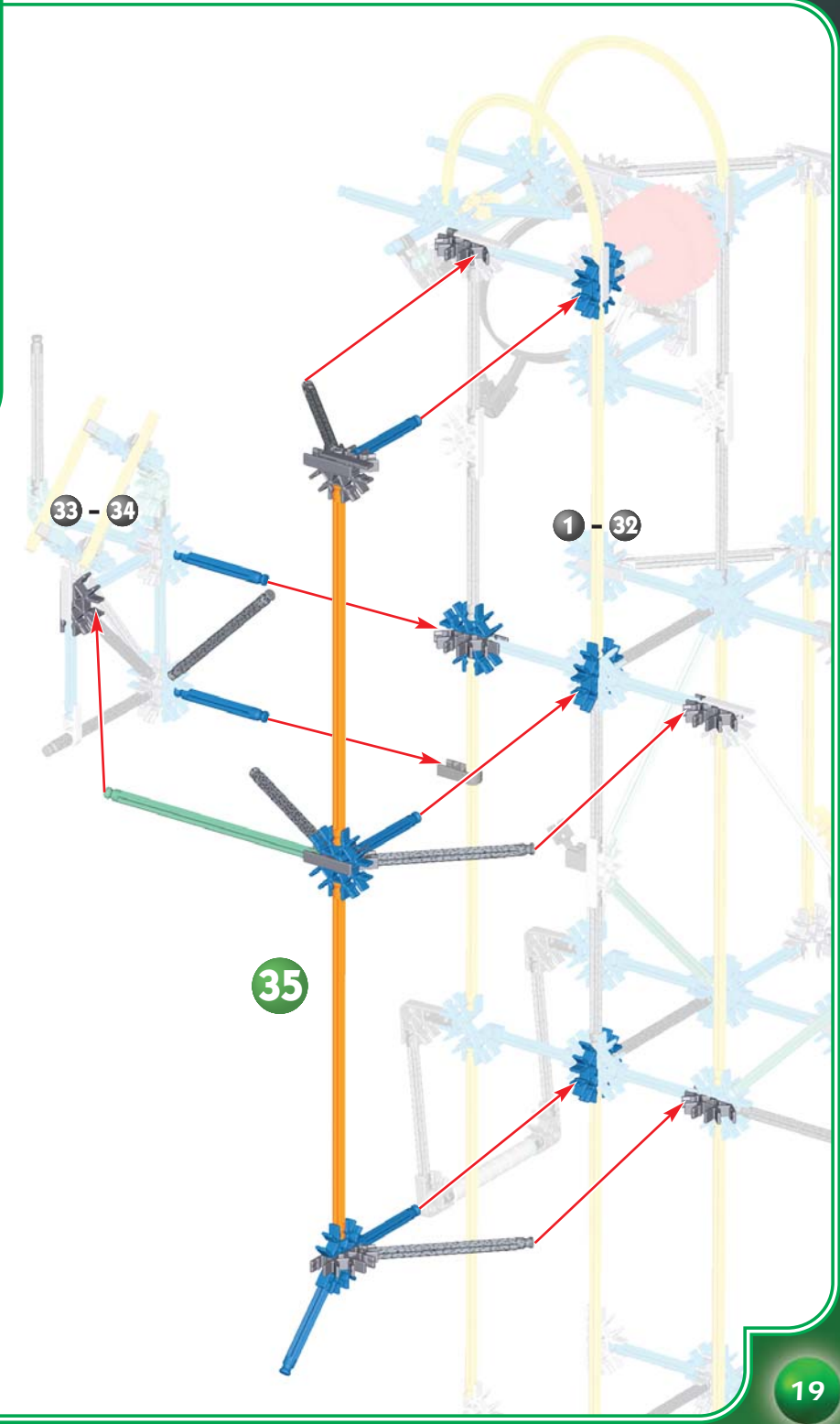
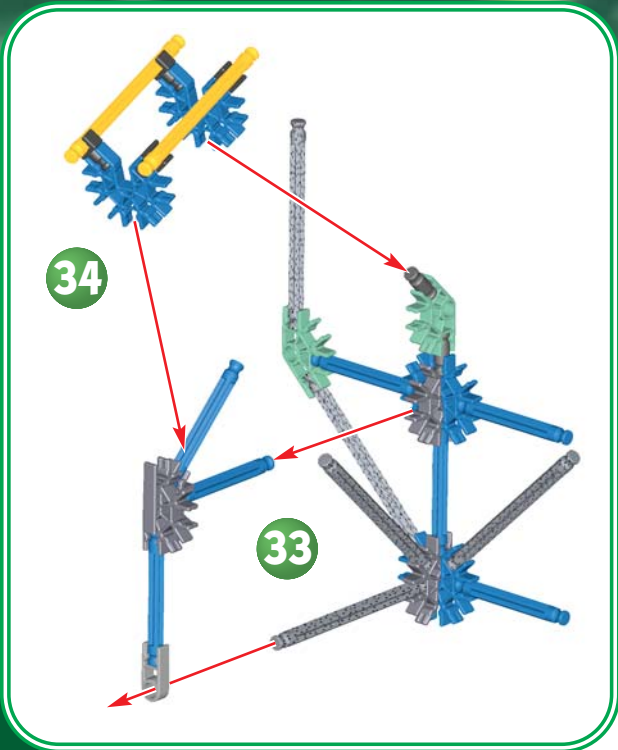

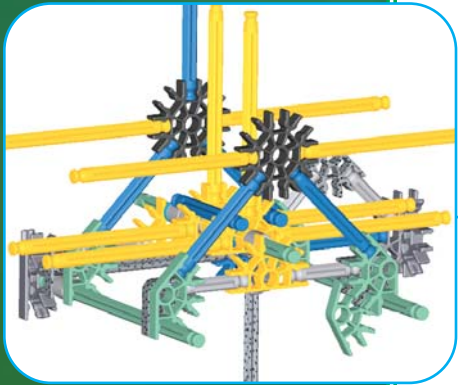
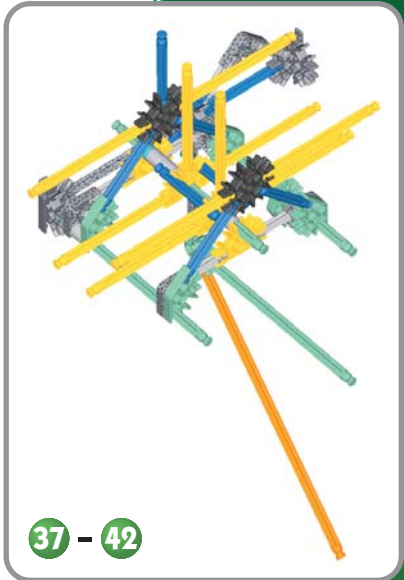
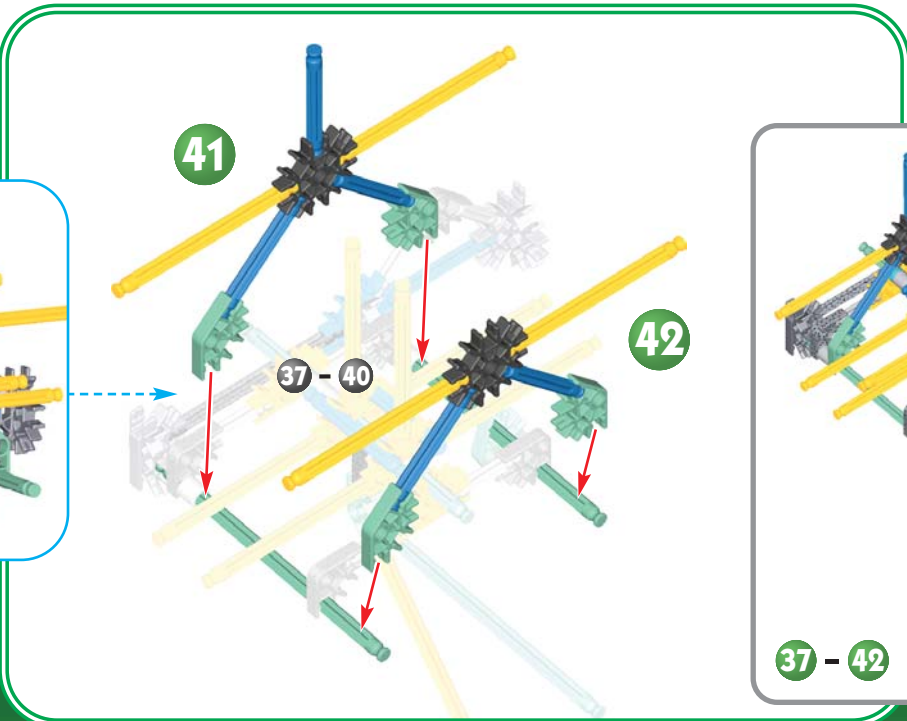
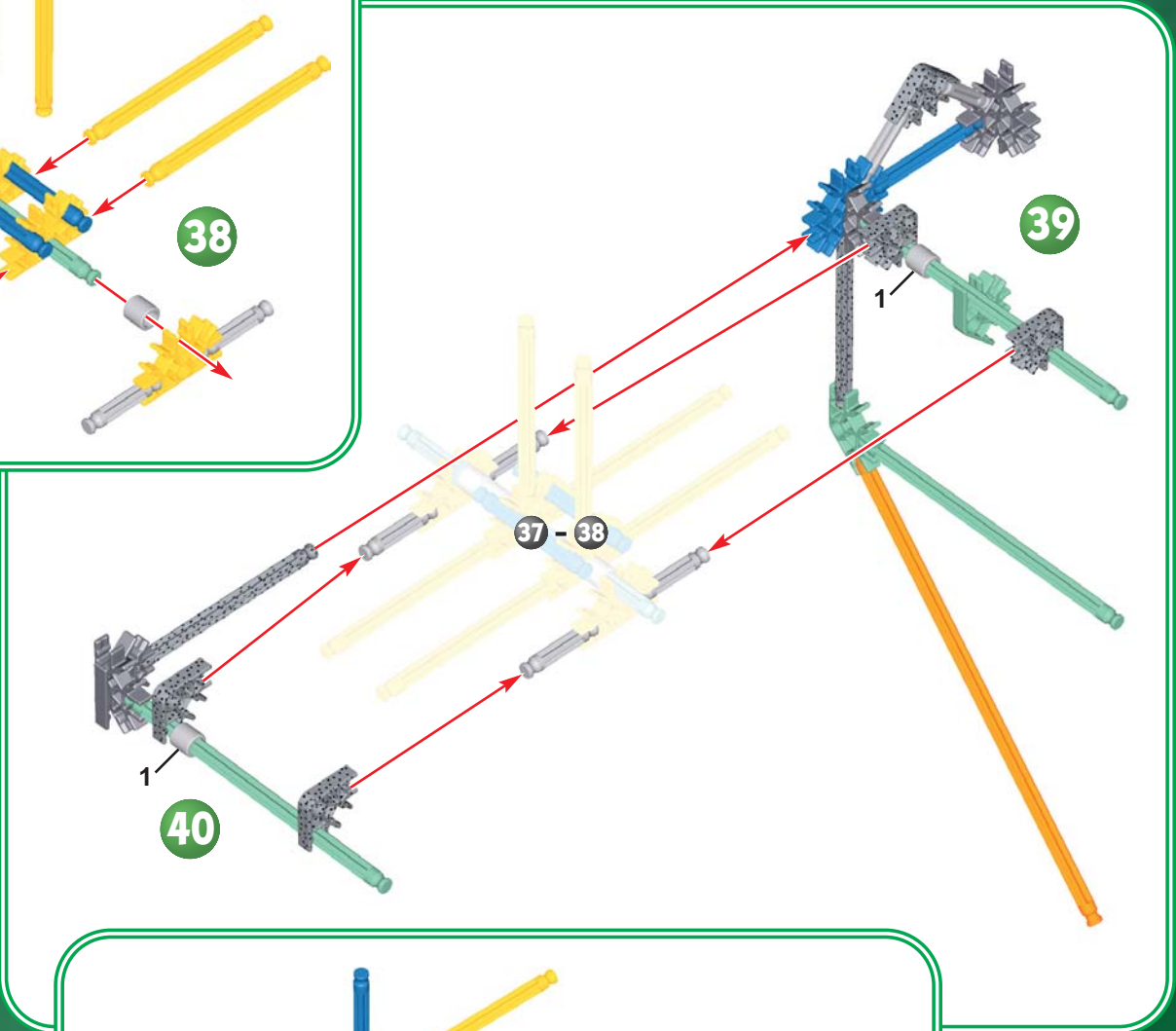
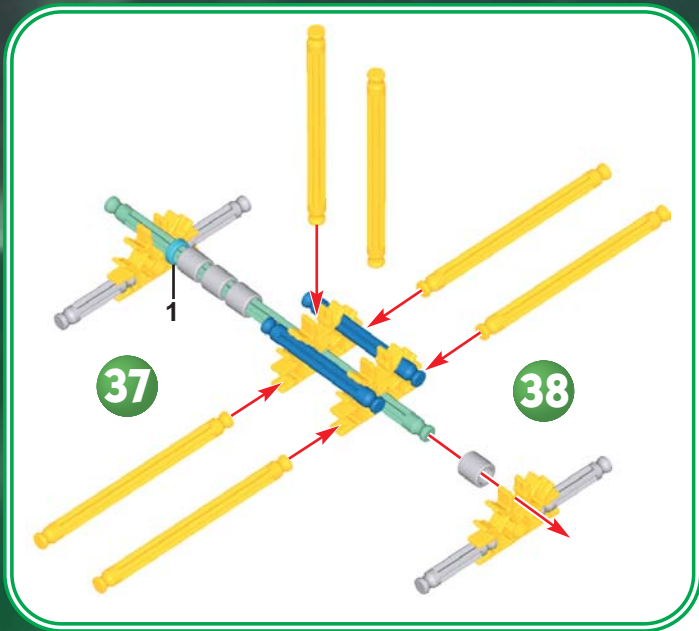

43

37 - 42

1 - 36

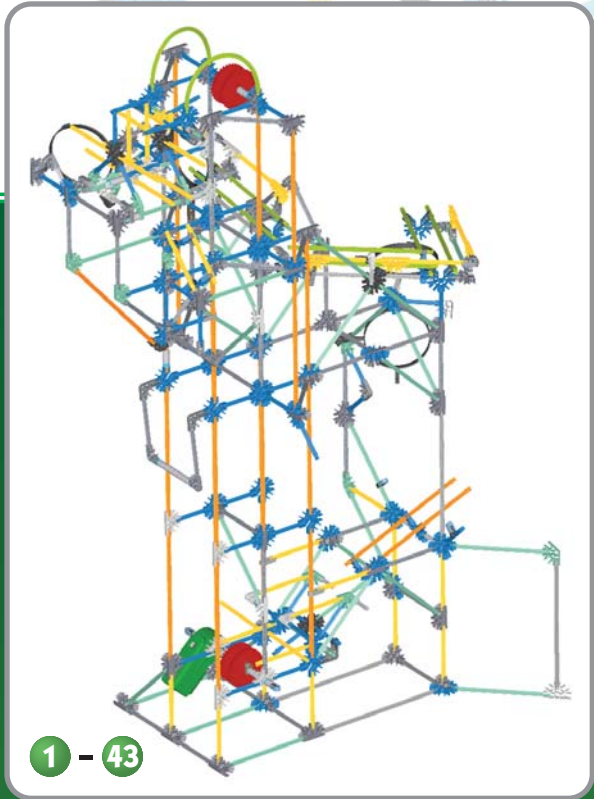

 x80



x4

44

16

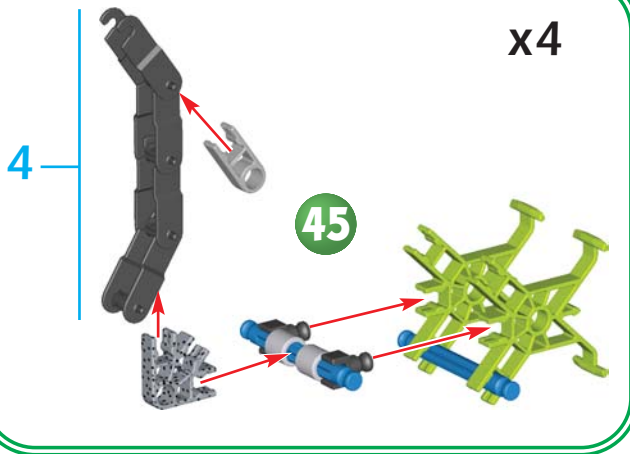

x4

45



- ENG** Do not connect yet.
- F** Ne fais pas encore la connexion.
- E** Todavía no la conectes.
- D** Halt! Noch nicht festmachen.
- NL** Nog niet aan mekaar koppelen.



- ENG** **IMPORTANT:** Attach Chain Links in the same direction.
- F** **IMPORTANT:** Attache les chaînon dans le même sens.
- E** **IMPORTANTE:** Conecta los Eslabones de la Cadena en la misma dirección.
- D** **WICHTIG:** Befestige die Kettenglieder immer in die gleiche Richtung.
- NL** **BELANGRIJK:** Maak de ketenschakels vast in dezelfde richting.

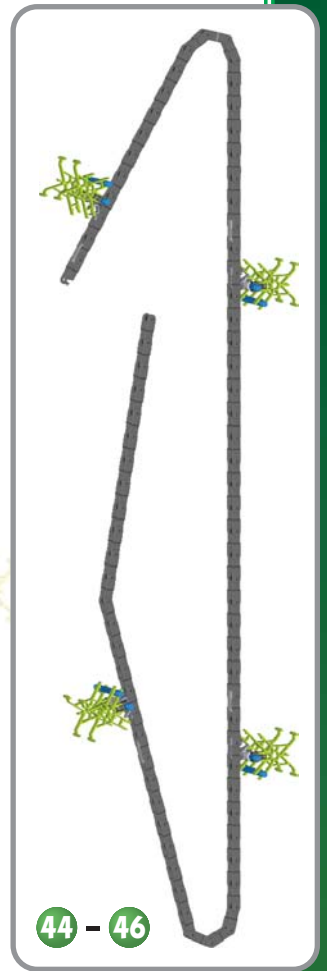
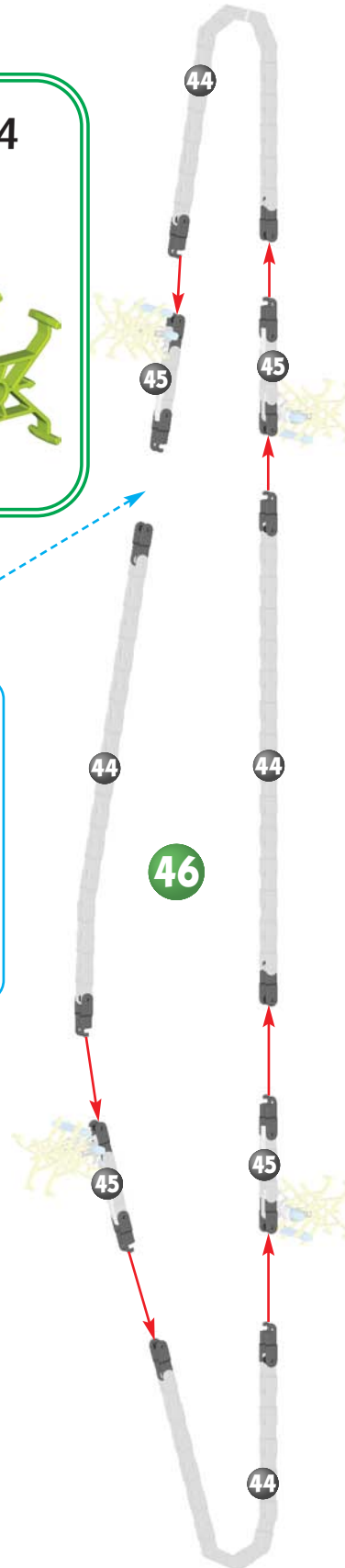

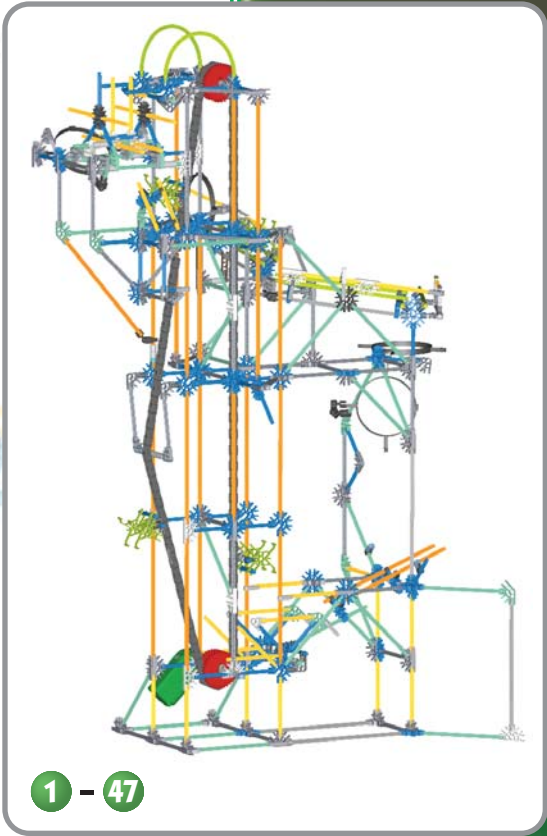
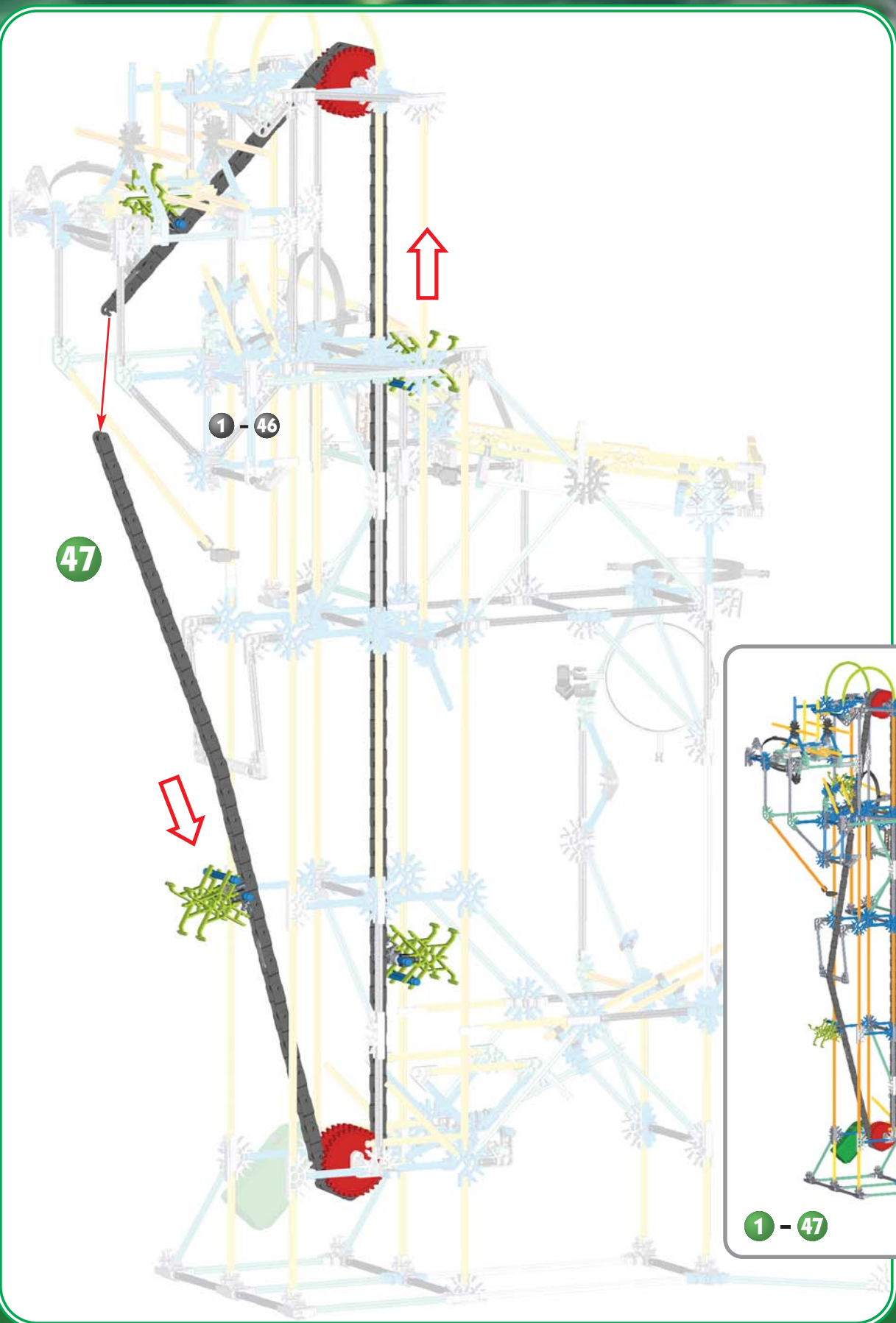

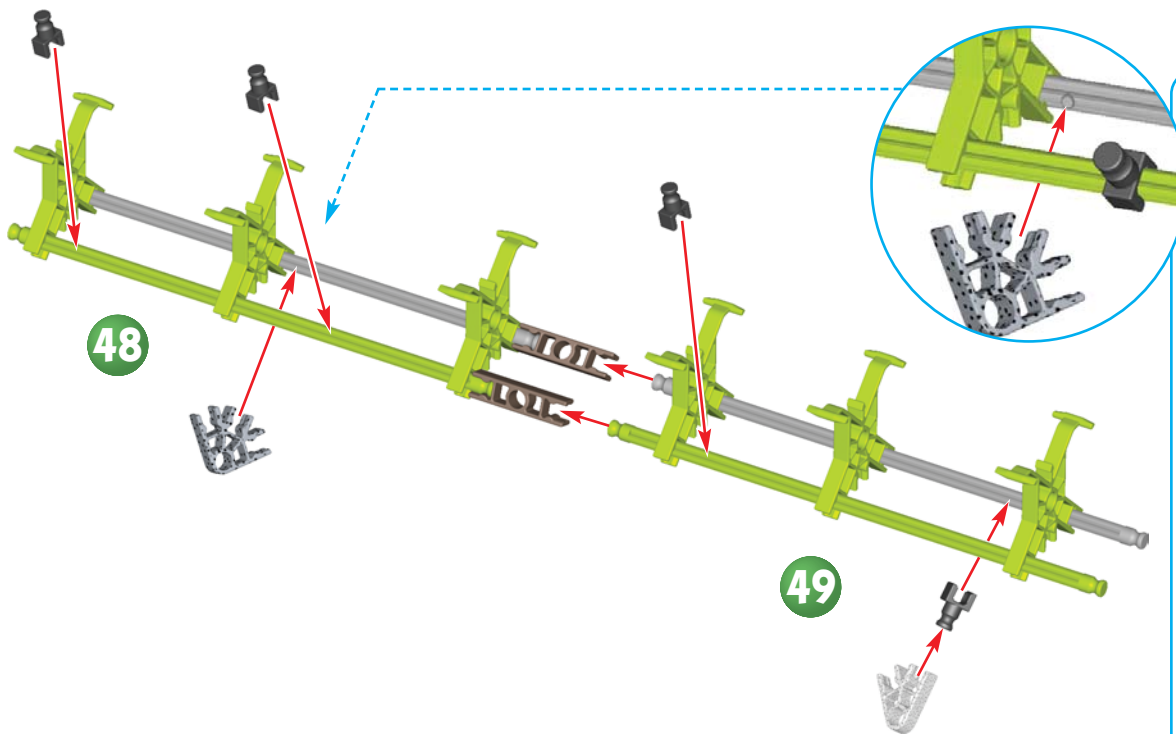

ENG There is a small dot in the middle of each gray Rod. Attach the Connector there.

F Au centre de chaque tige orange se trouve un petit point. C'est là où tu dois fixer les connecteurs de tige noirs.

E En el medio de cada Varilla anaranjada hay un pequeño punto. Conecta los pequeños conectores de Varilla, de color negro, allí.

D In der Mitte jedes orangefarbenen Stabs befindet sich ein kleiner Punkt. Hier werden die kleinen schwarzen Verbindungsstäbe angebracht.

NL Er is een kleine stip in het midden van elke oranje stang. Bevestig de kleine zwarte stangconnectoren daar.

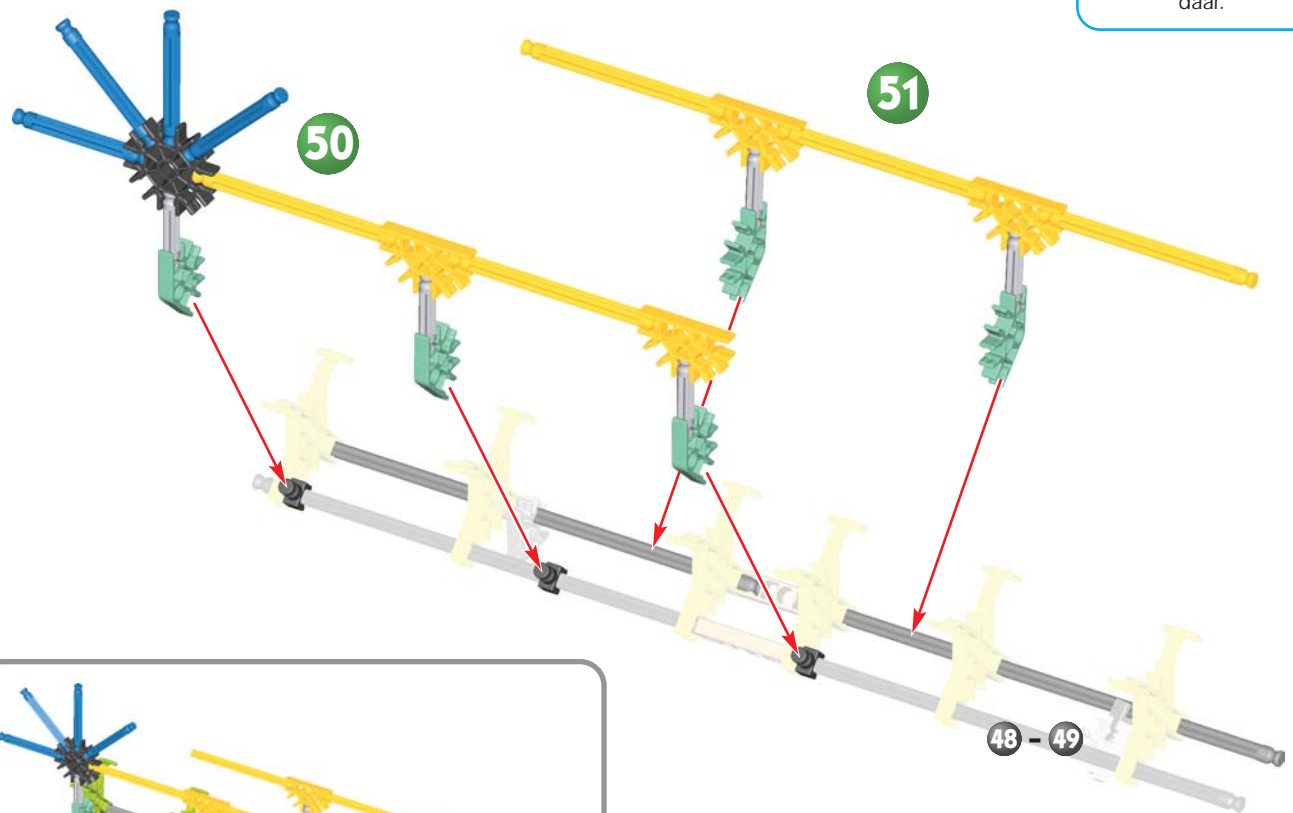

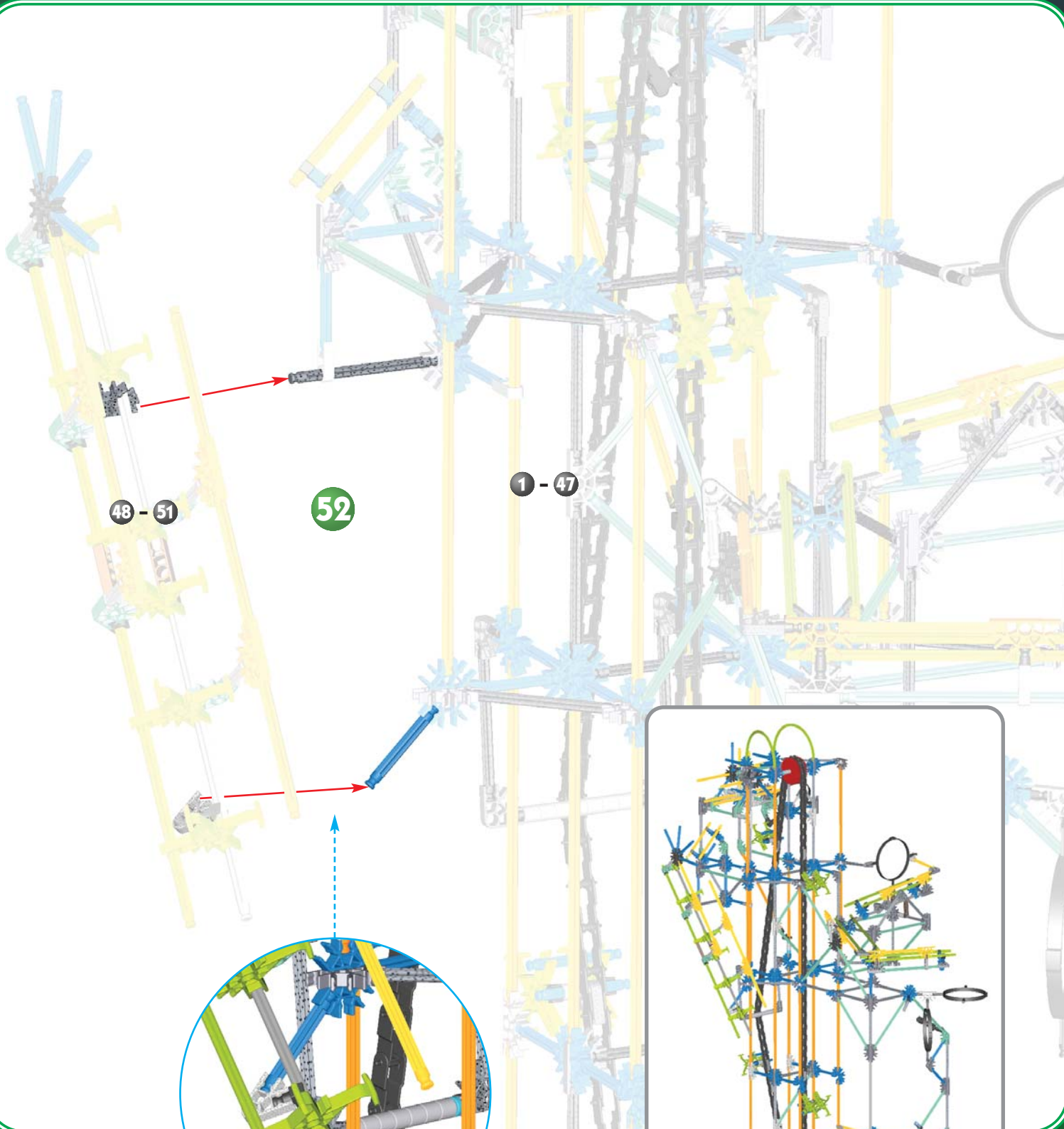

48 - 51

52

1 - 47

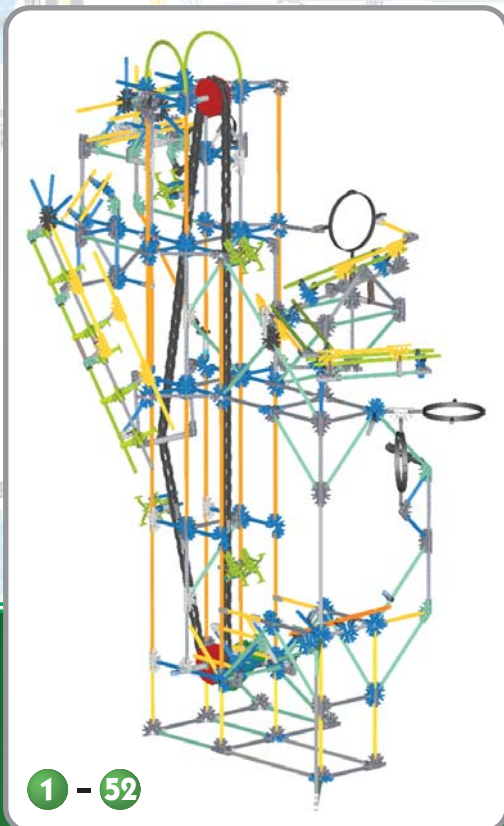

1 - 52



53

1 - 52



x6

- ENG** Number of Track Connectors.
- F** Nombre de connecteurs de voie.
- E** Número de Conectores del Carril.
- D** Zahl der Gleisanschlüsse.
- NL** Aantal koppelstukken van het spoor.

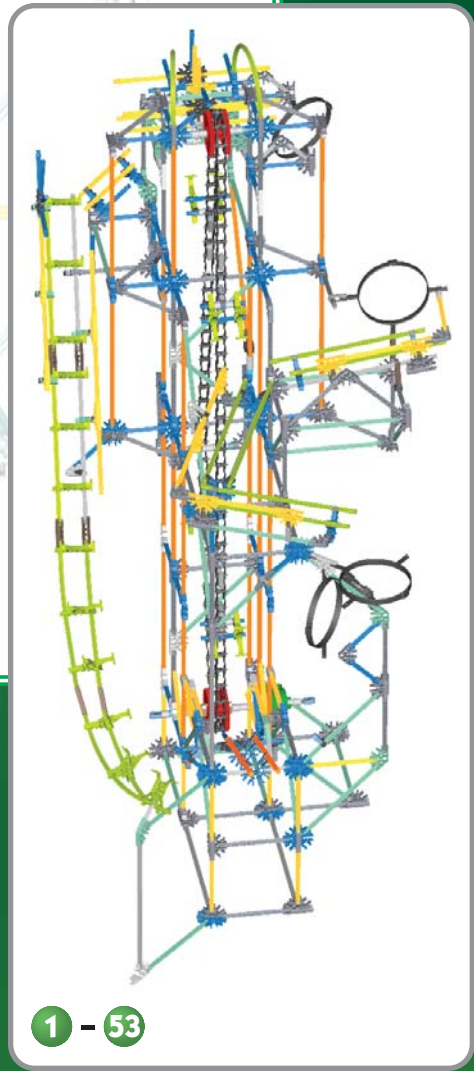

1 - 53

x6



1 - 53

54

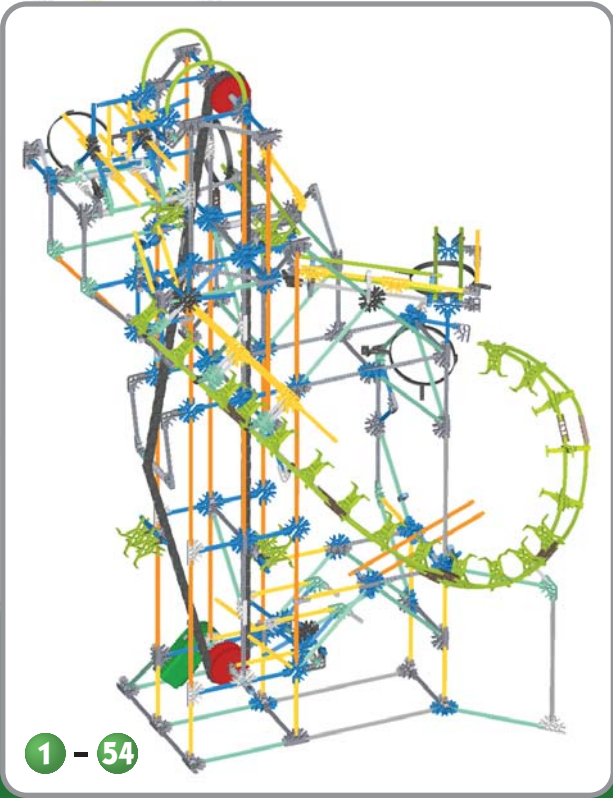

1 - 54



1 - 54

55

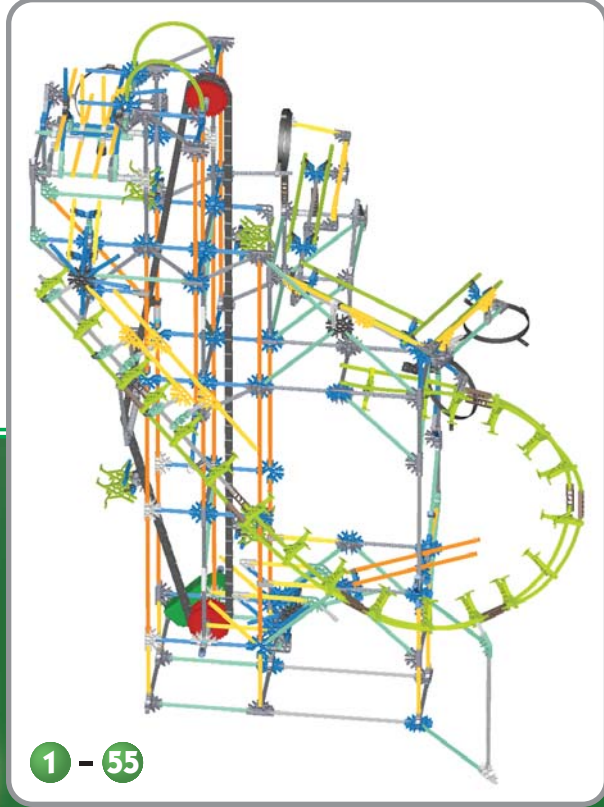
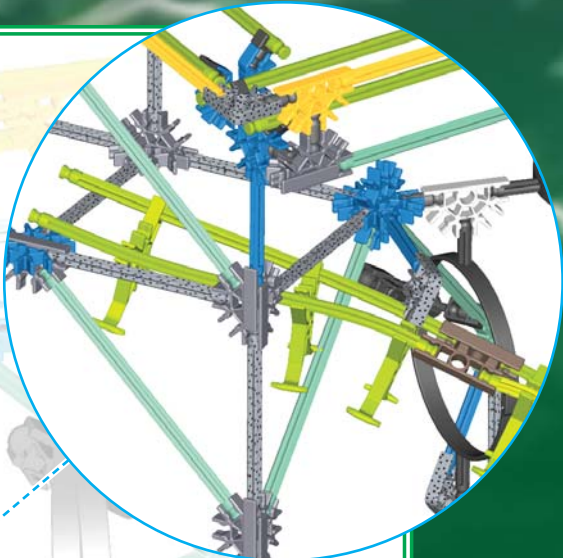

- ENG** Start
- F** Départ
- E** Empieza
- D** Start hier
- NL** Begin

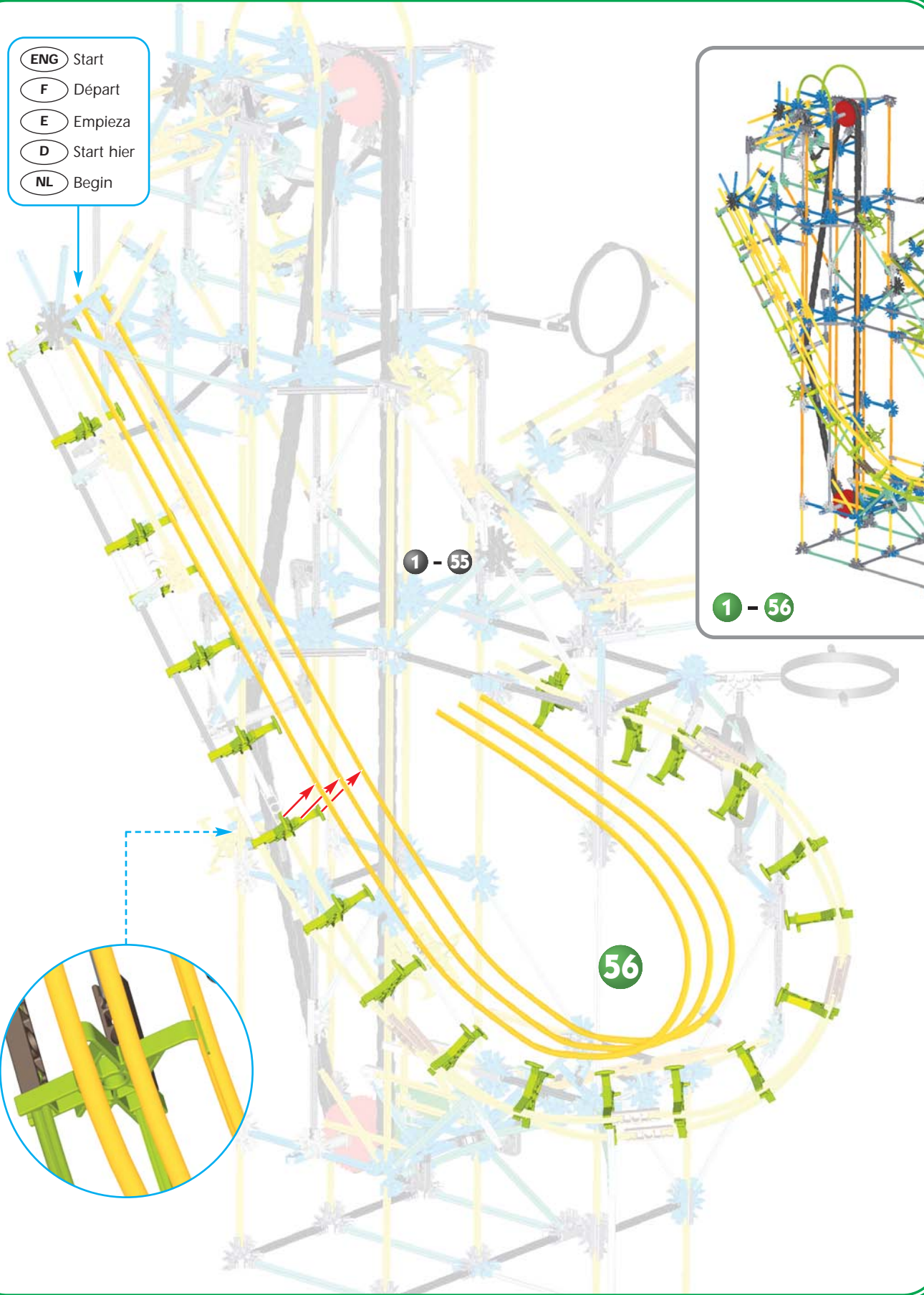

1 - 55

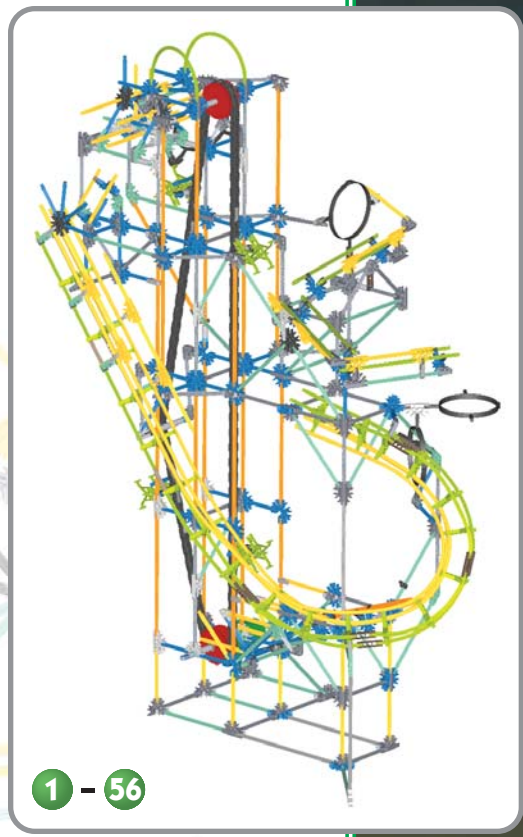

1 - 56

56

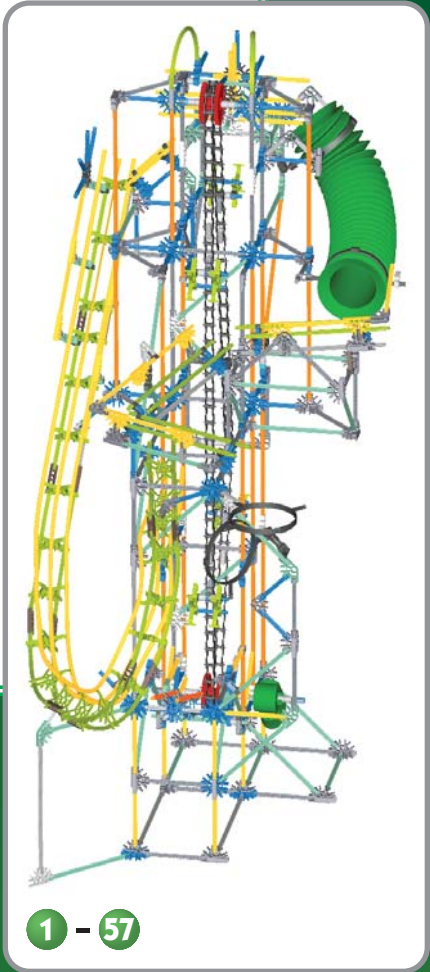
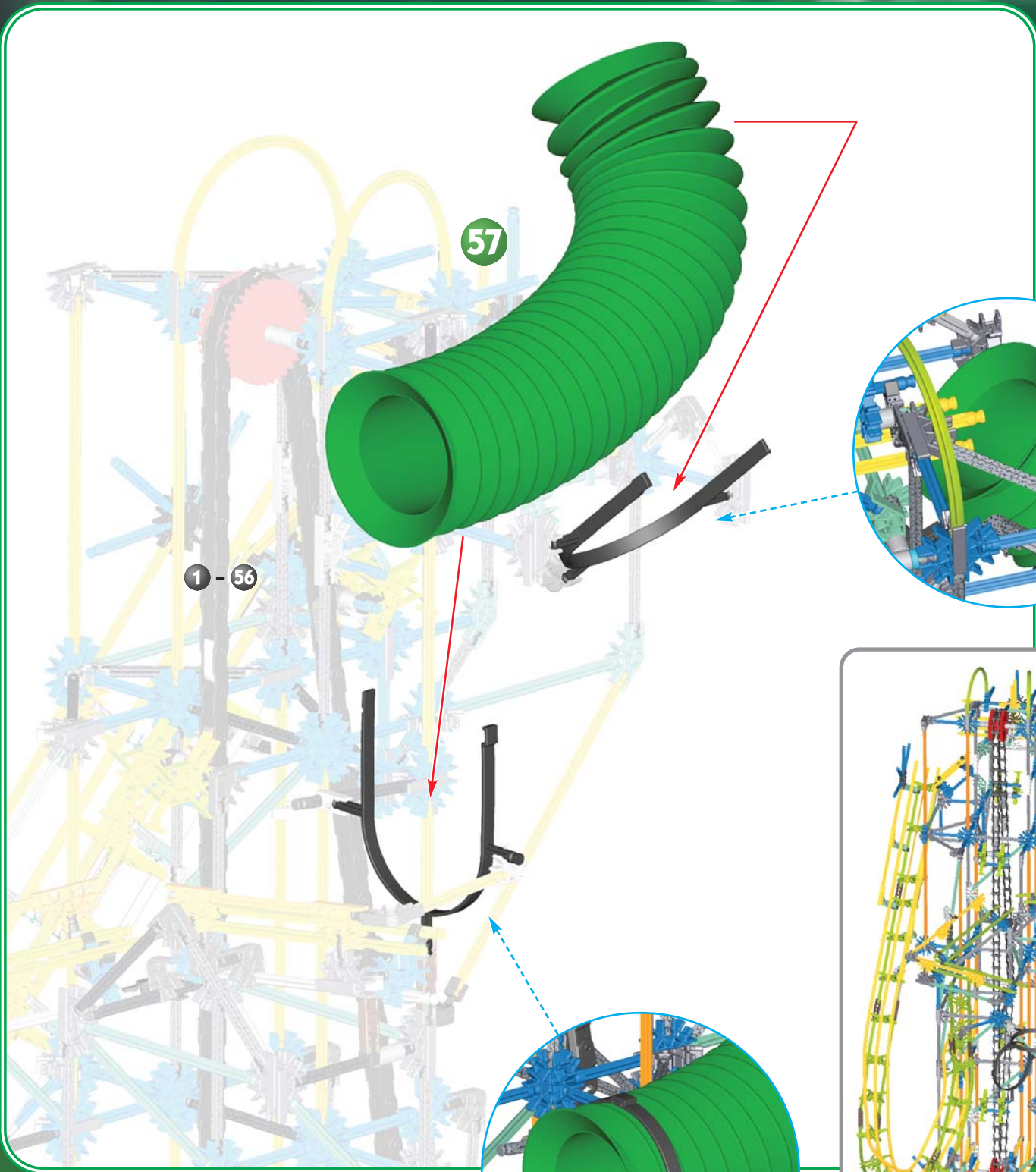

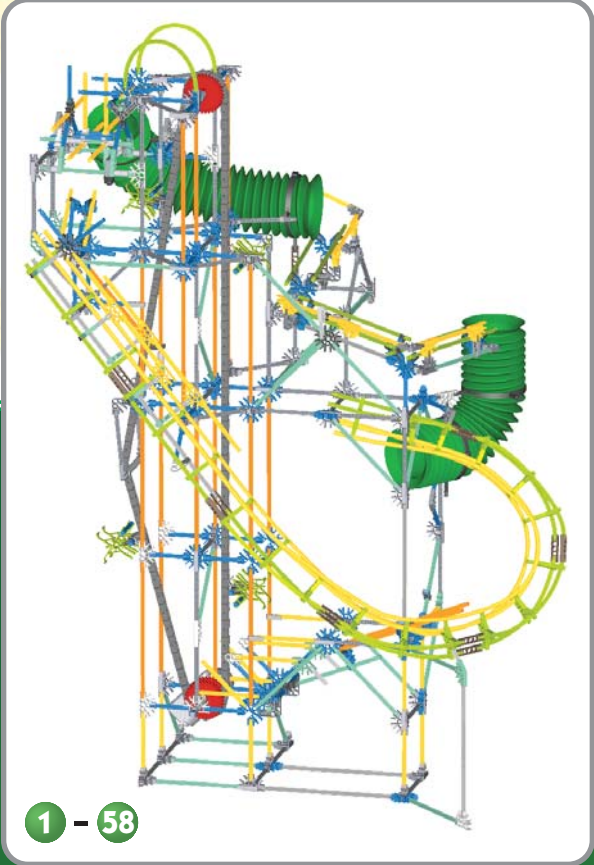
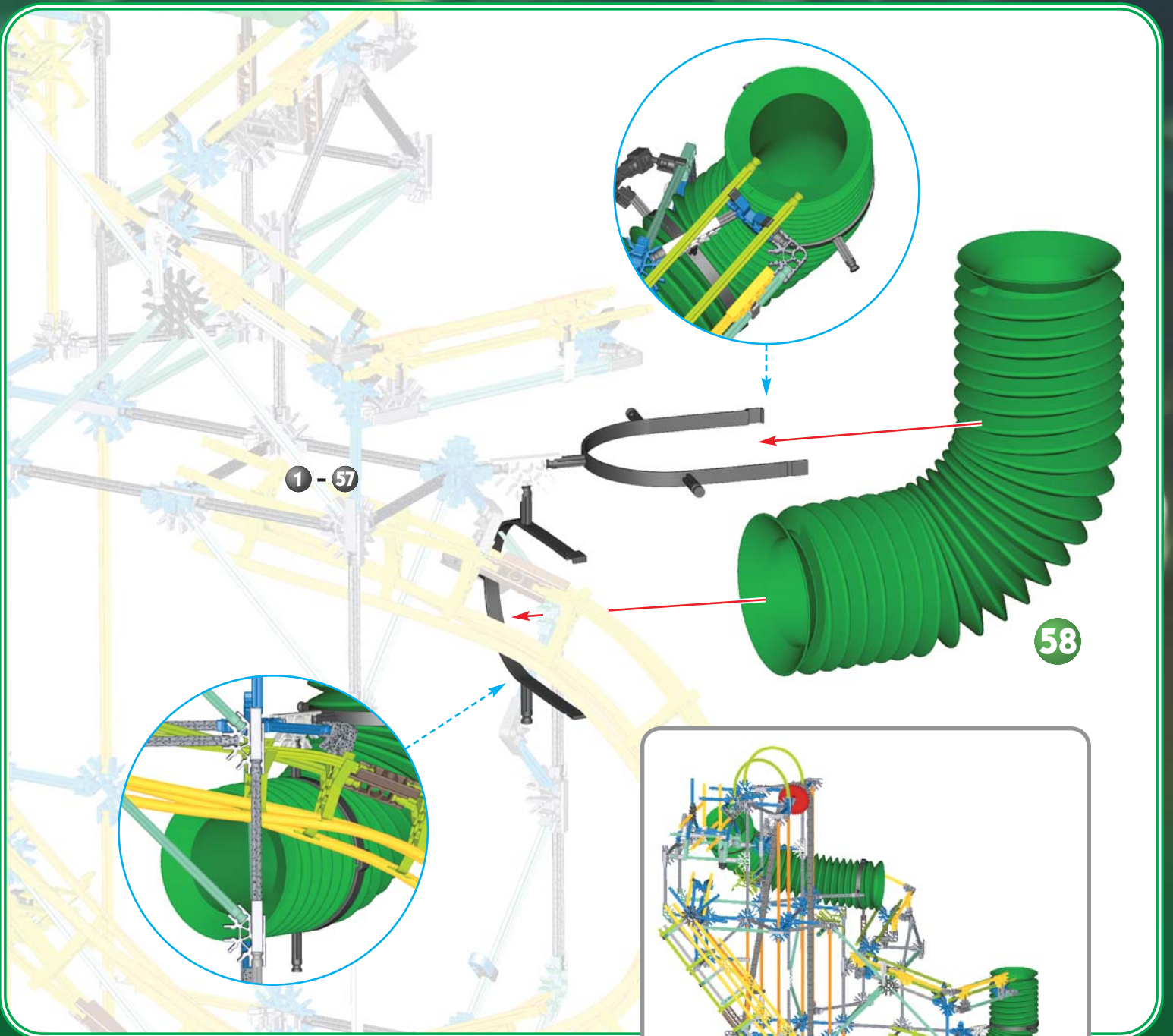

(ENG) Attach graphics.

(F) Attache les dessins graphiques.

(E) Fija los dibujos.

(D) Befestige die Grafikbilder.

(NL) Maak het grafisch kunstwerk vast.



Launchin' Lizard

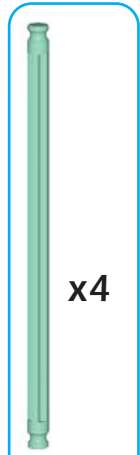
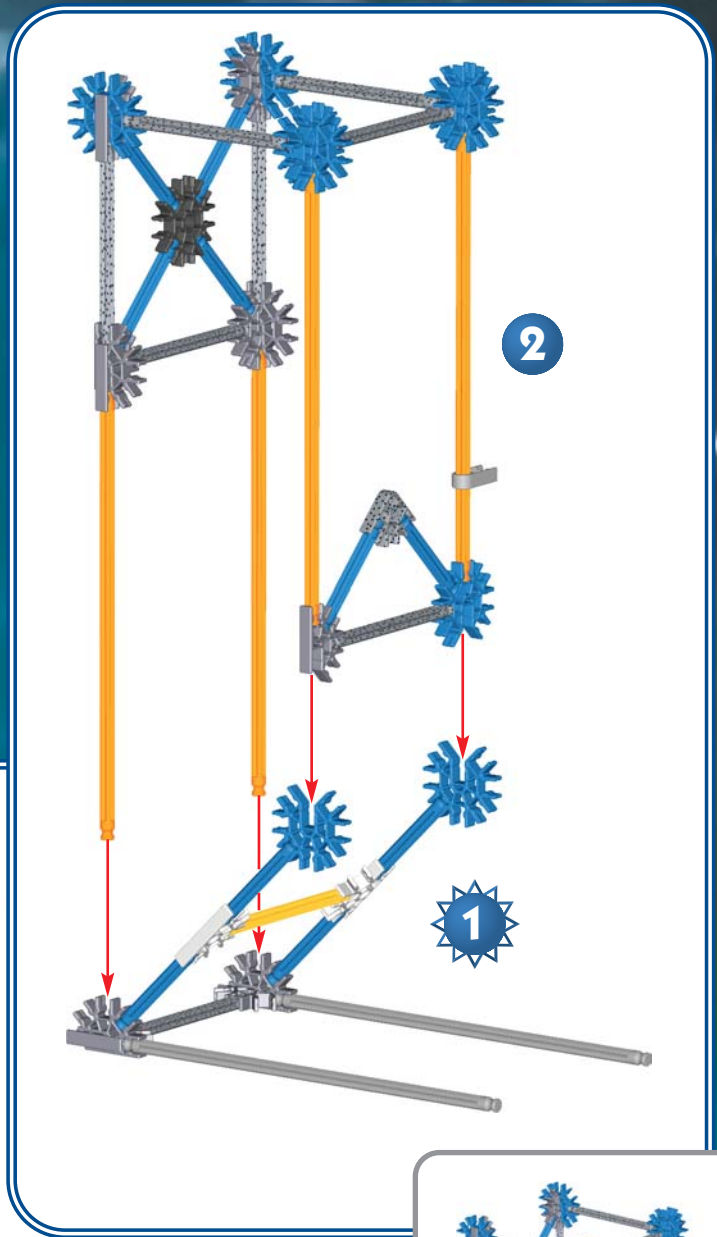

x4

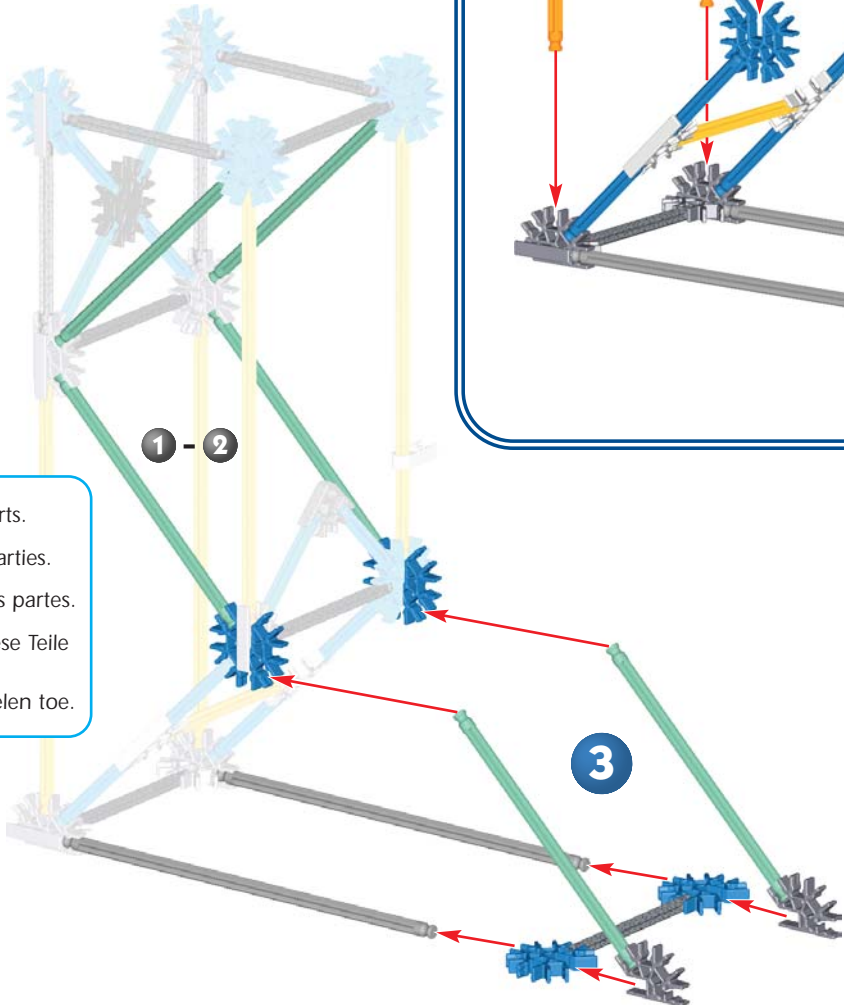

1 - 2

3

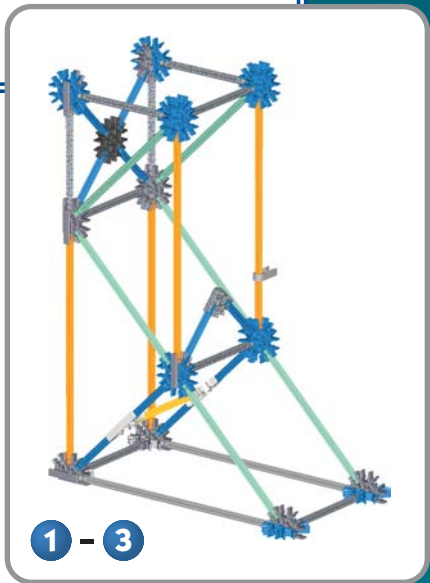

1 - 3

- ENG** Add these parts.
- F** Ajouter ces parties.
- E** Agregue estas partes.
- D** Fügen Sie diese Teile hinzu.
- NL** Voeg deze delen toe.

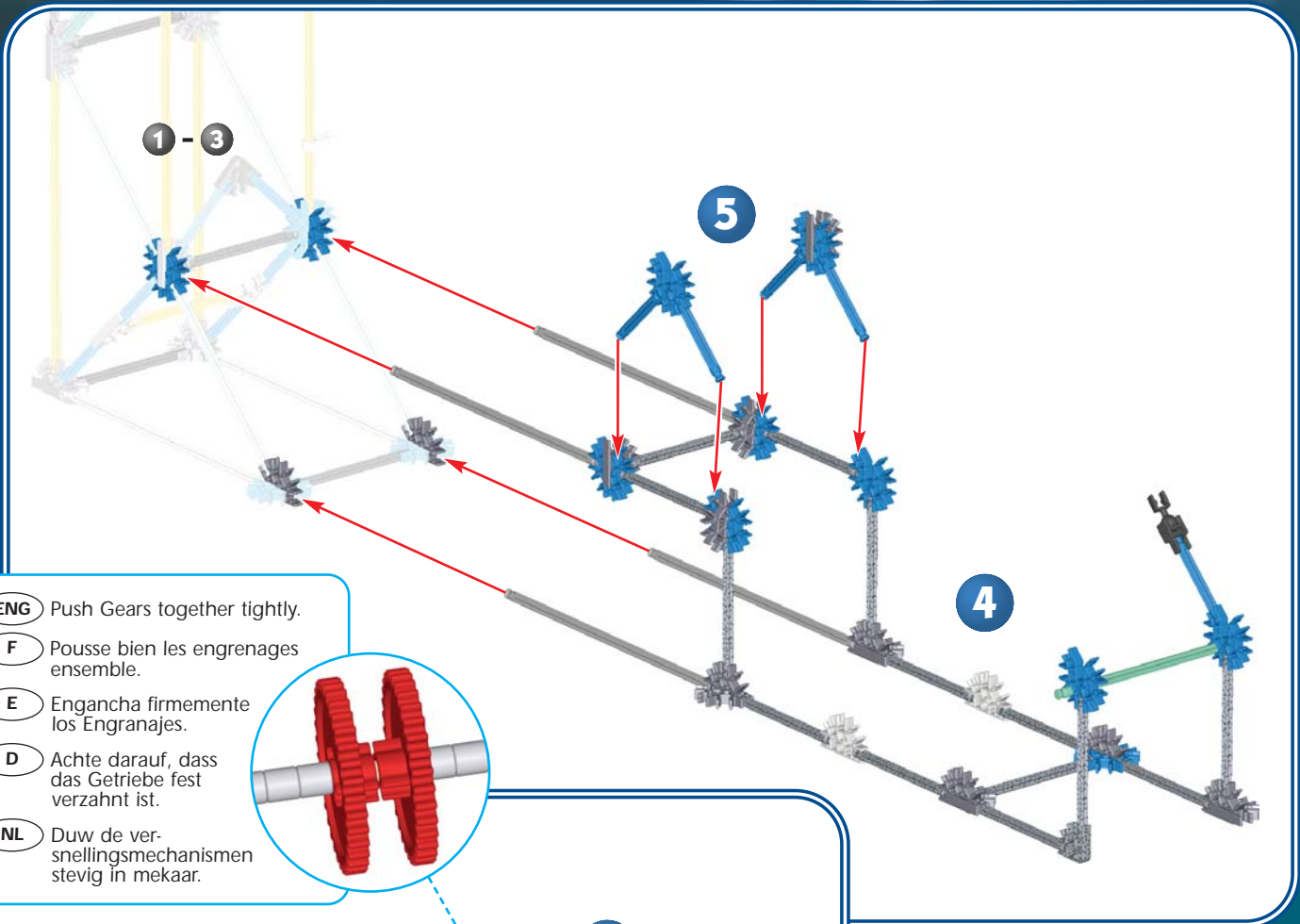

- ENG** Push Gears together tightly.
- F** Pousse bien les engrenages ensemble.
- E** Engancha firmemente los Engranajes.
- D** Achte darauf, dass das Getriebe fest verzahnt ist.
- NL** Duw de versnellingsmechanismen stevig in mekaar.

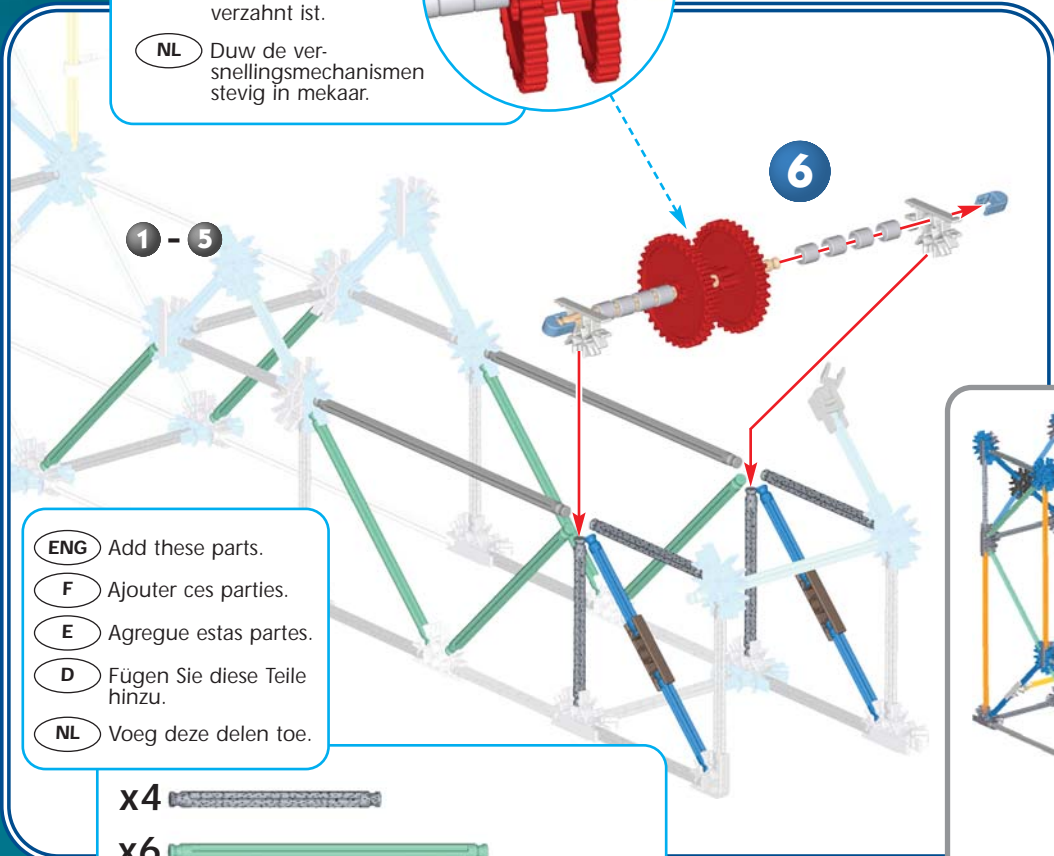
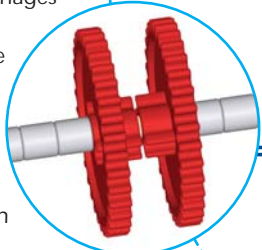

- ENG** Add these parts.
- F** Ajouter ces parties.
- E** Agregue estas partes.
- D** Fügen Sie diese Teile hinzu.
- NL** Voeg deze delen toe.

- x4**
- x6**
- x2**
- x2**

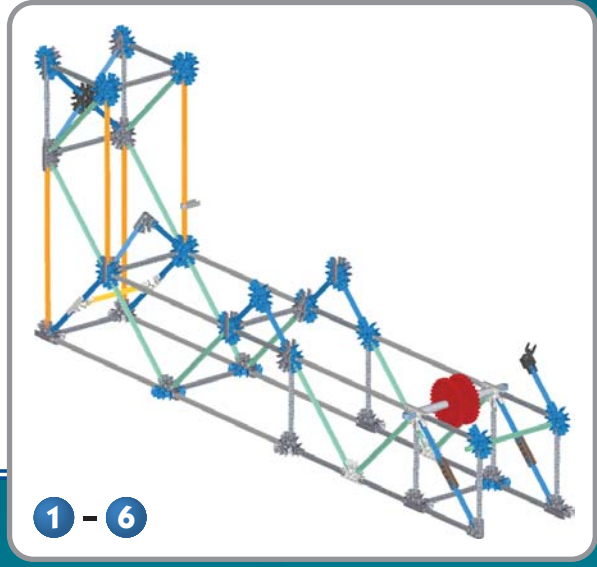

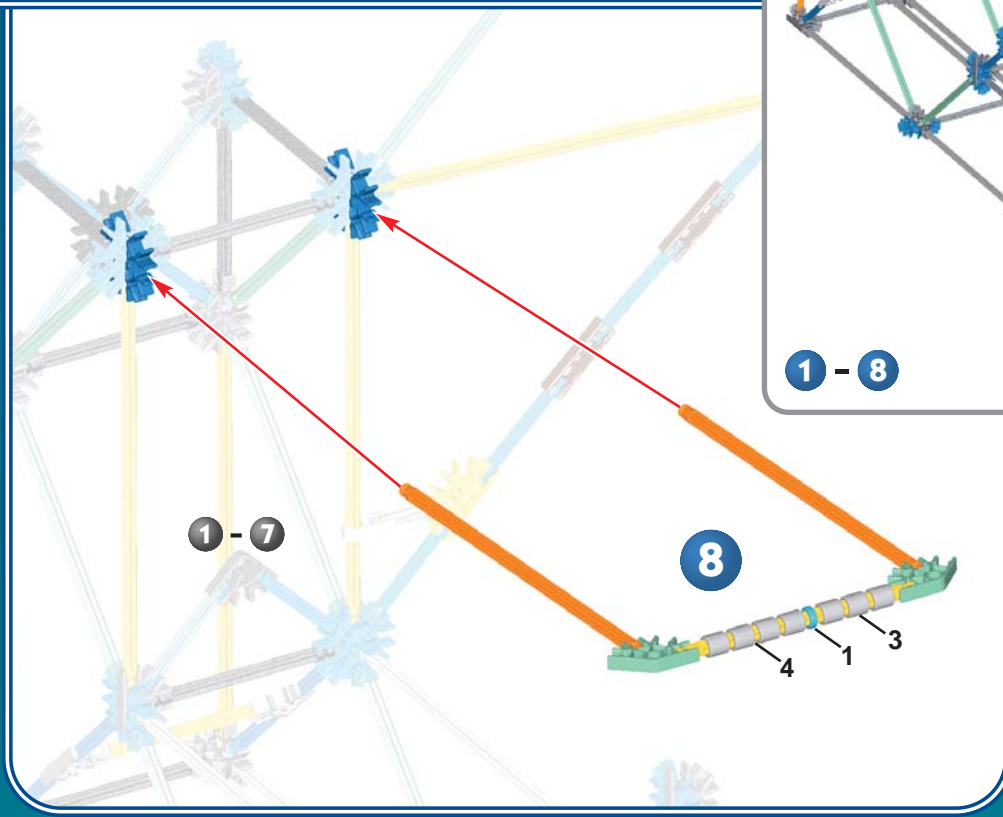
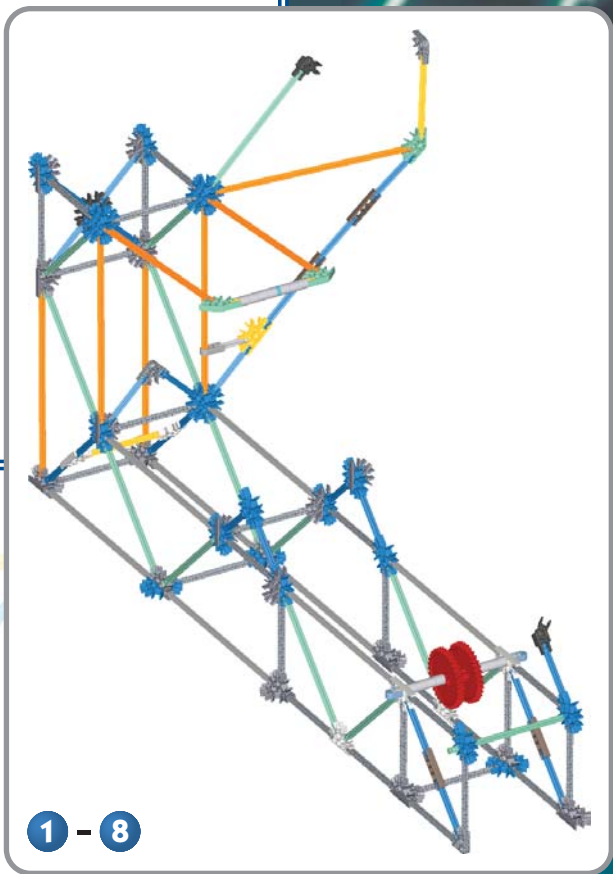
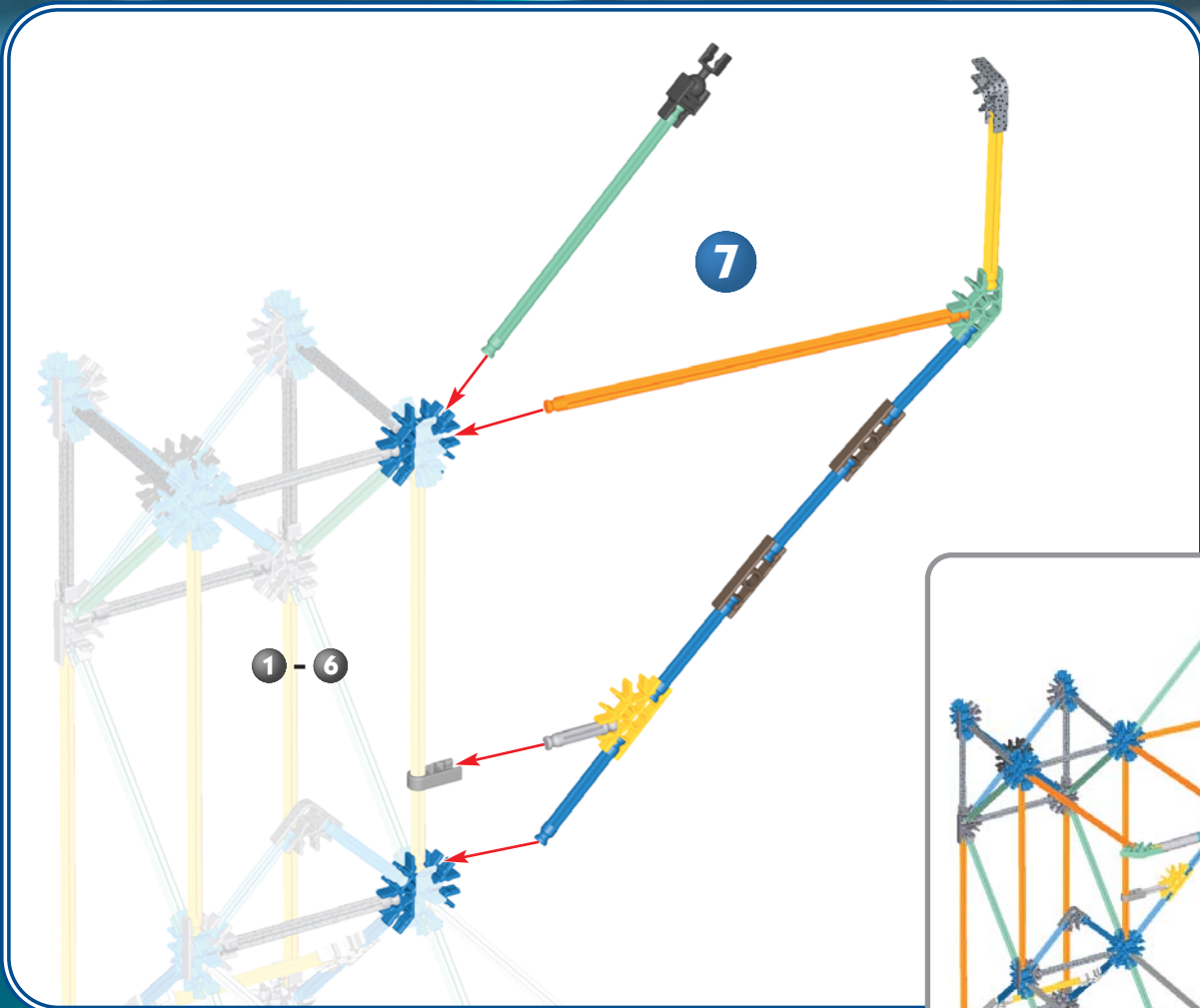

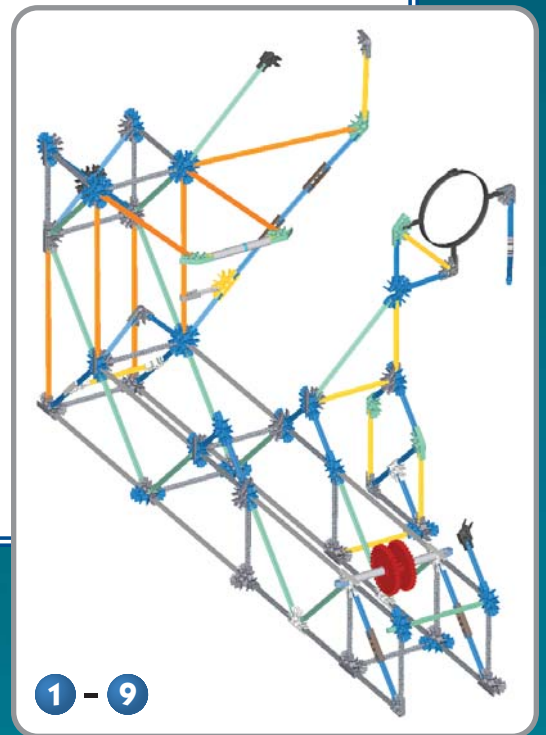
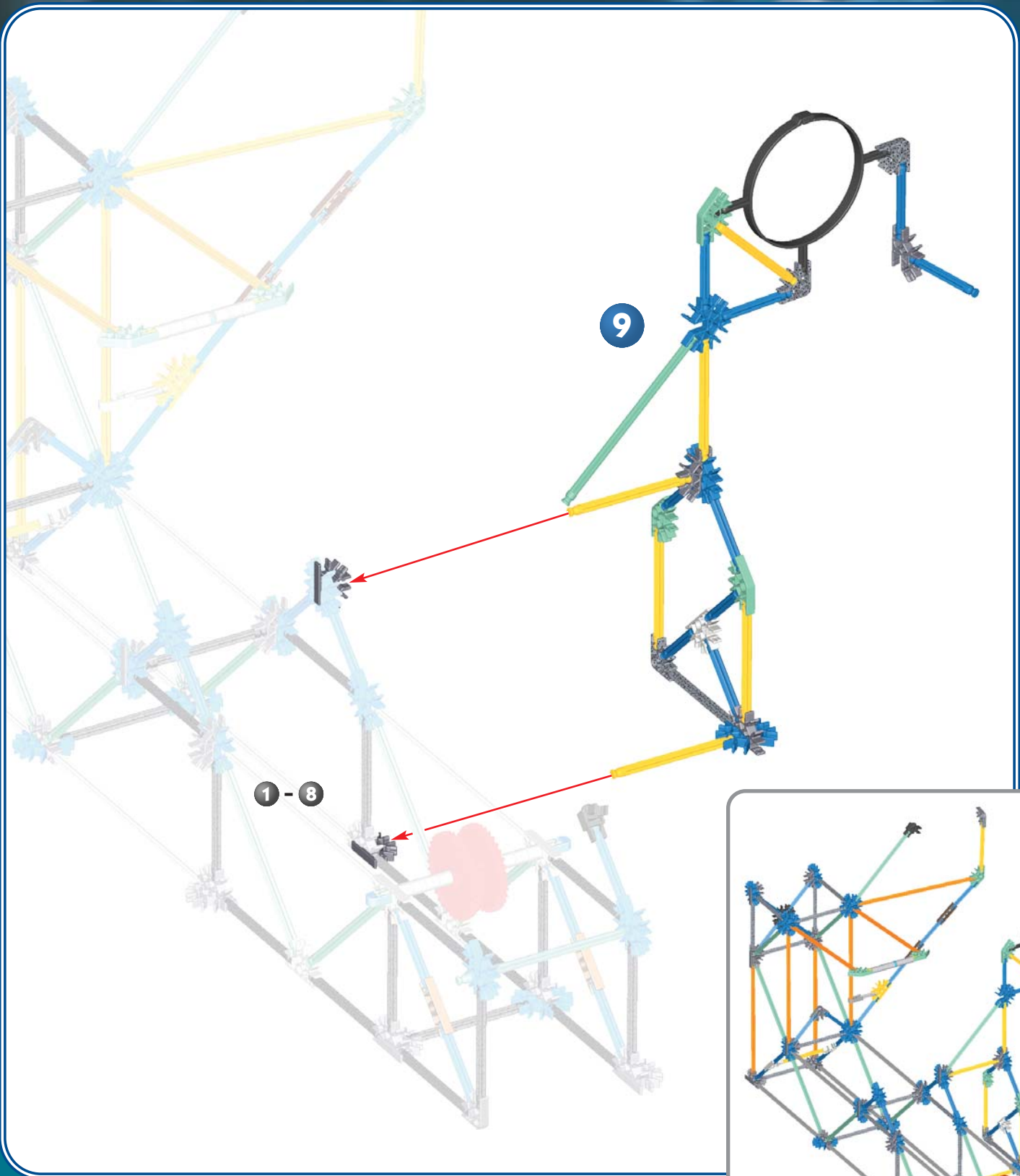

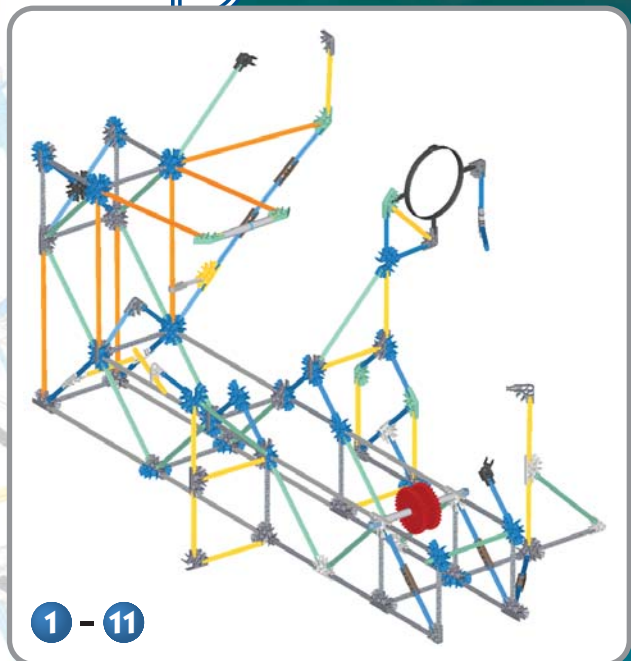
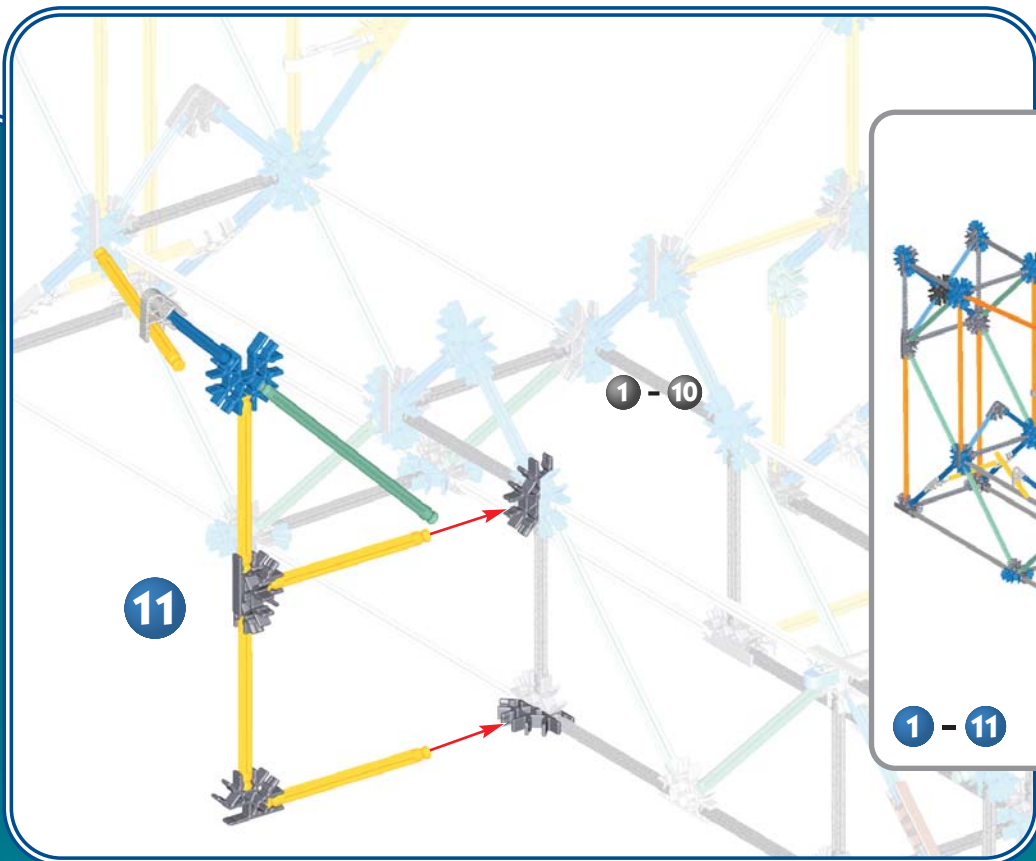
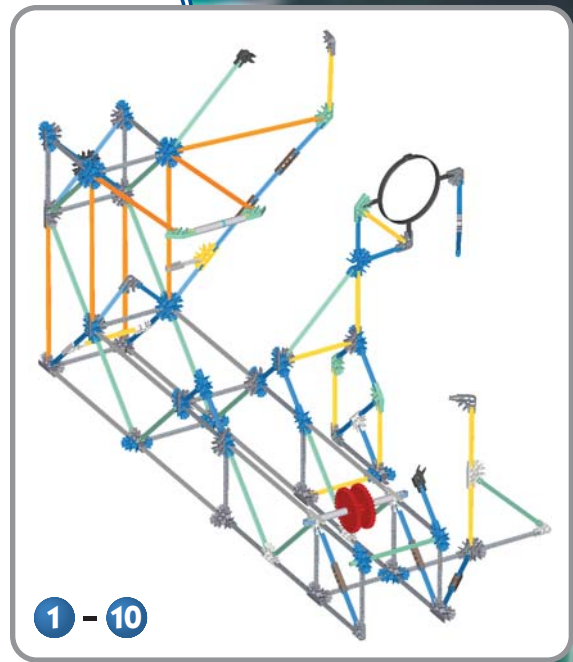
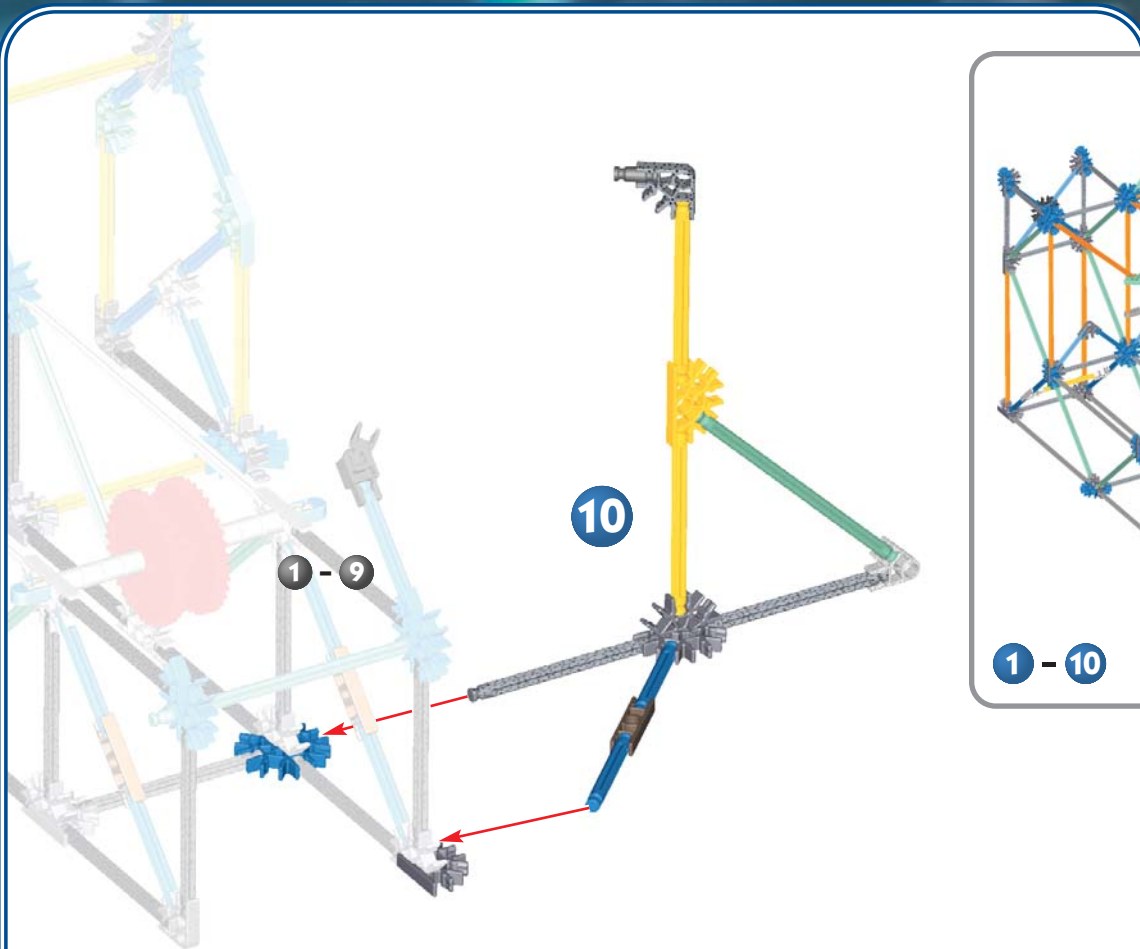

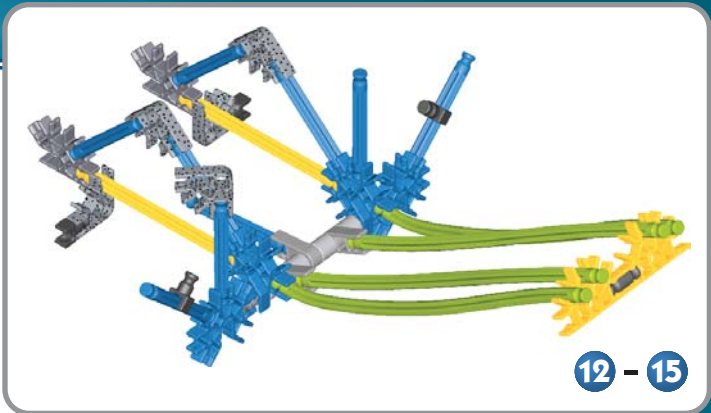
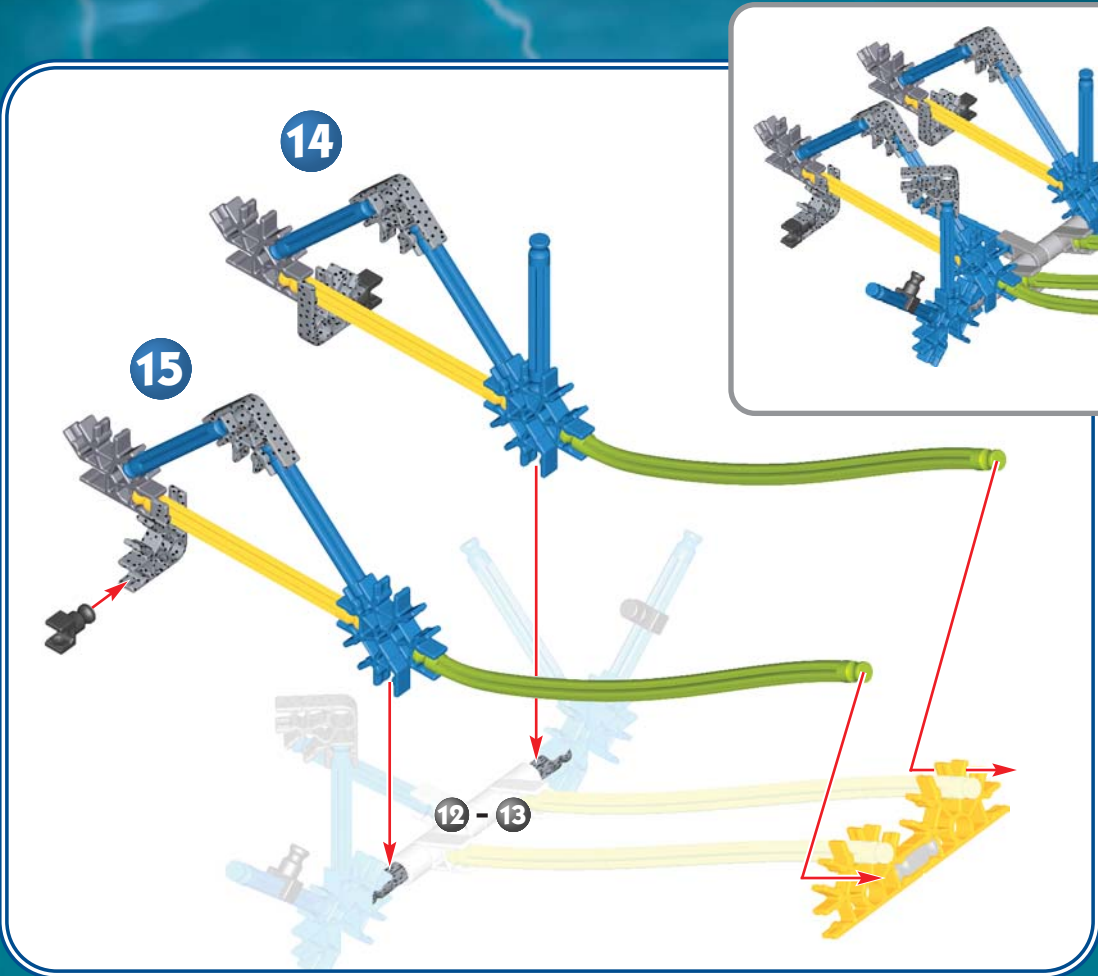
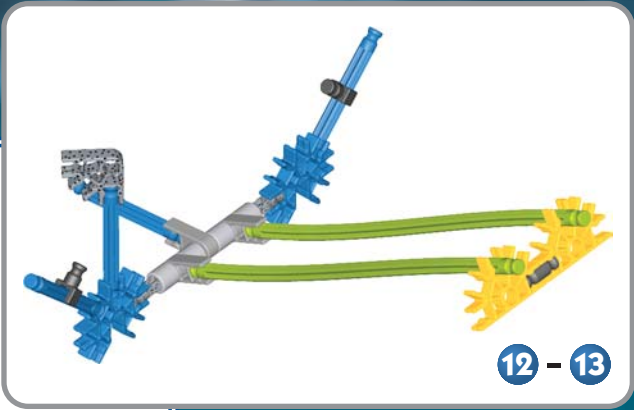
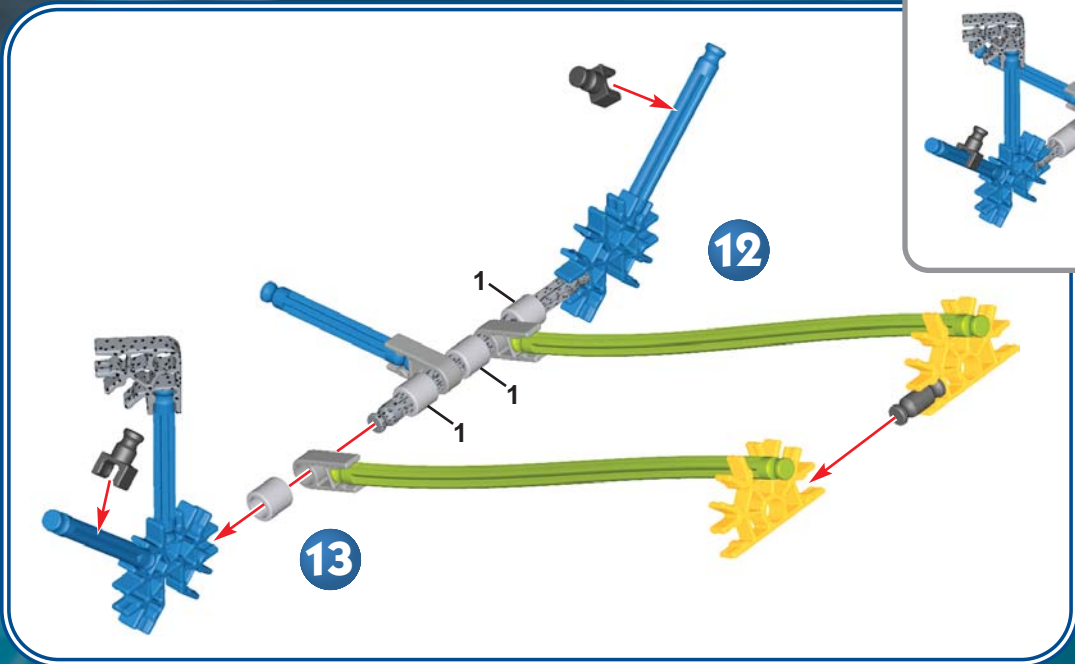

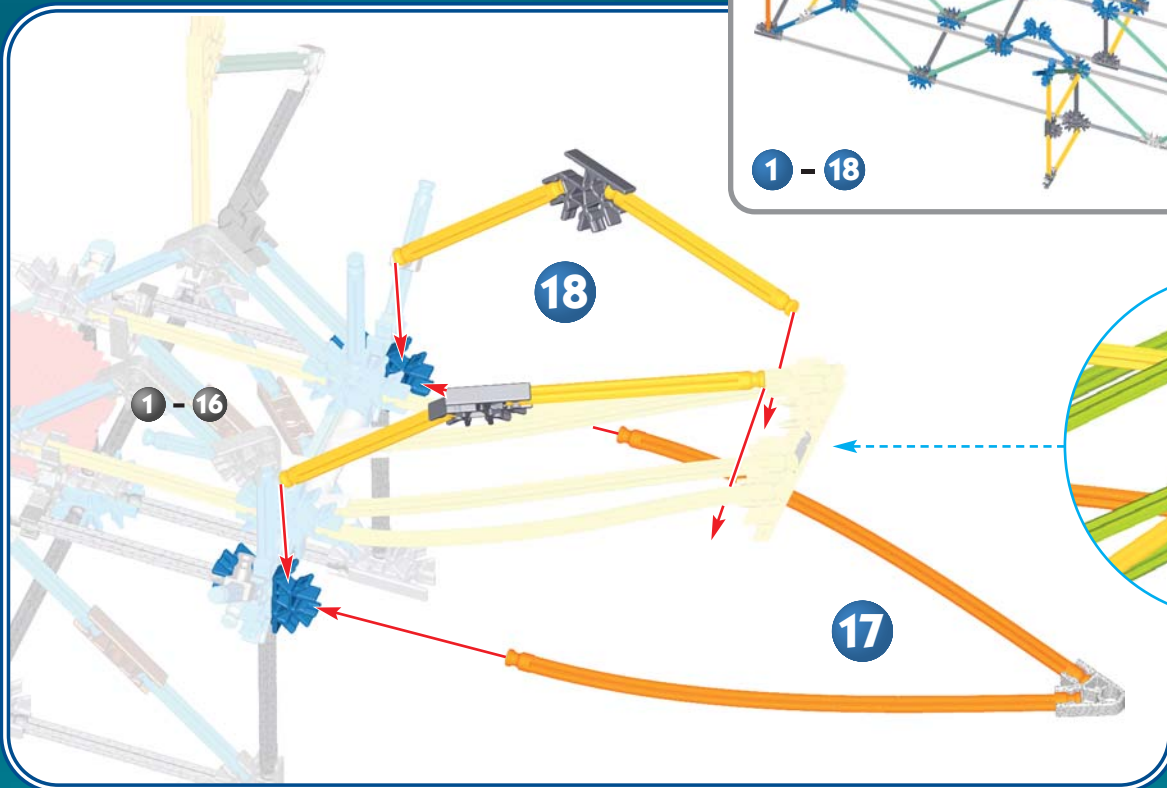
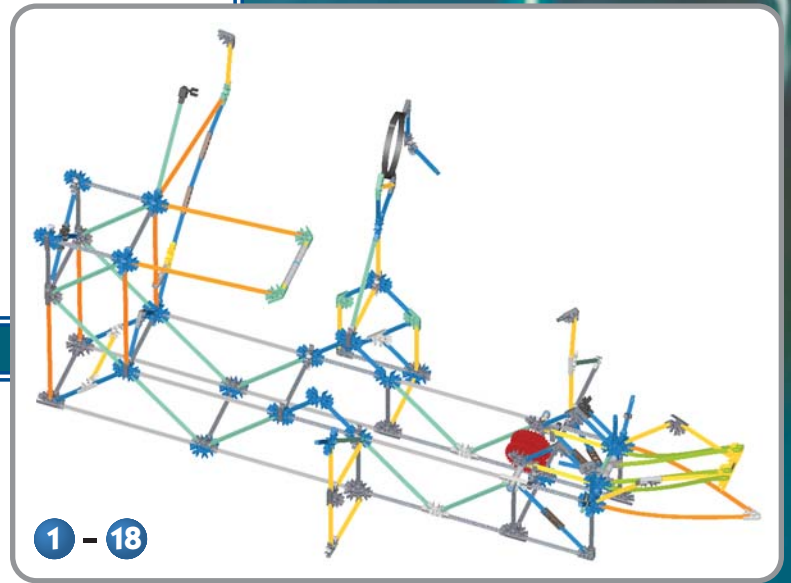
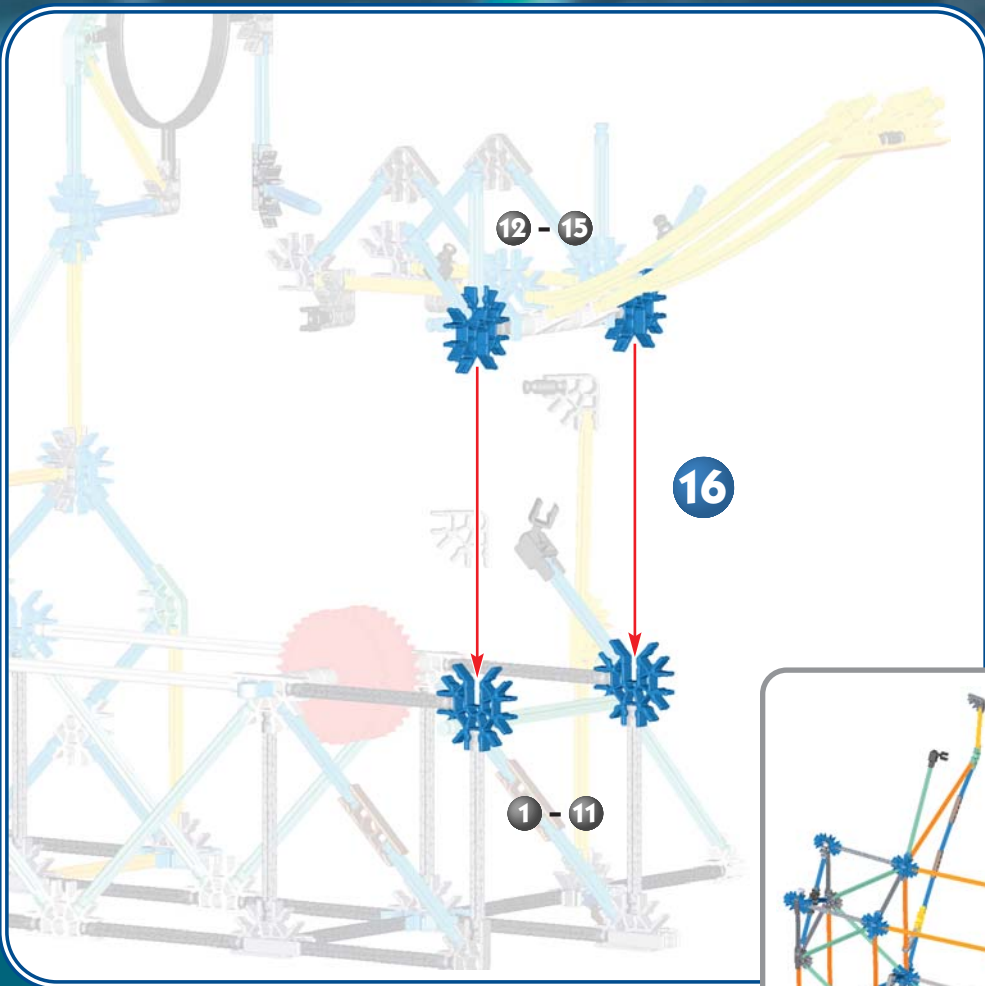

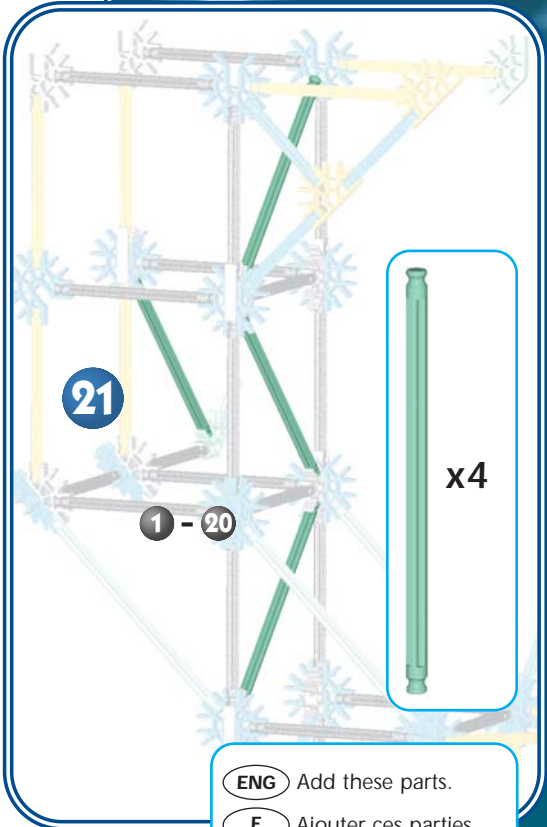
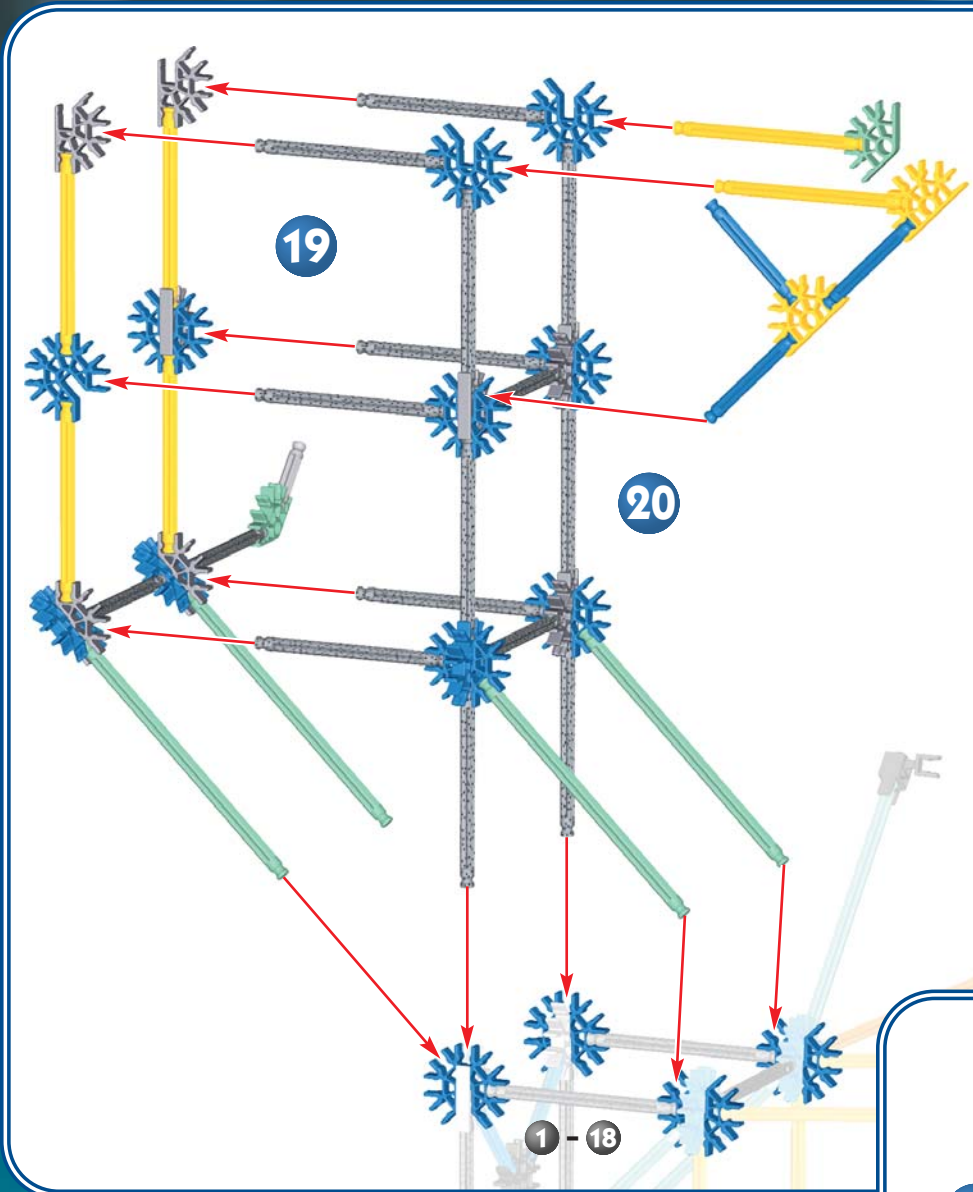

- ENG** Add these parts.
- F** Ajouter ces parties.
- E** Agregue estas partes.
- D** Fügen Sie diese Teile hinzu.
- NL** Voeg deze delen toe.

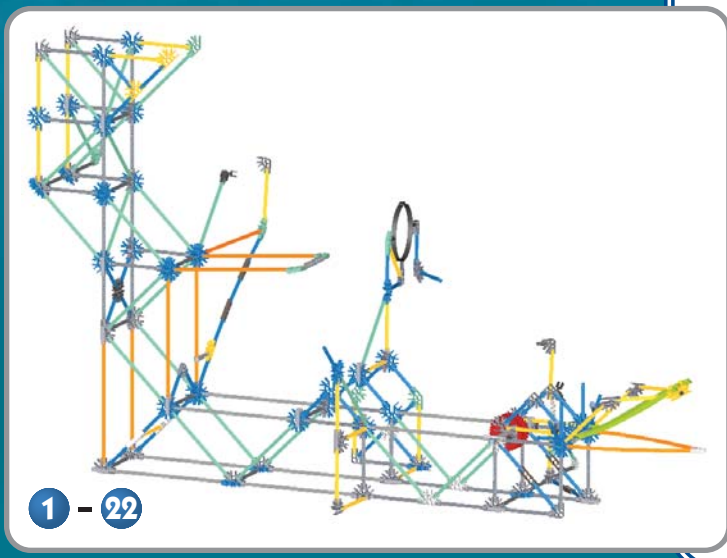
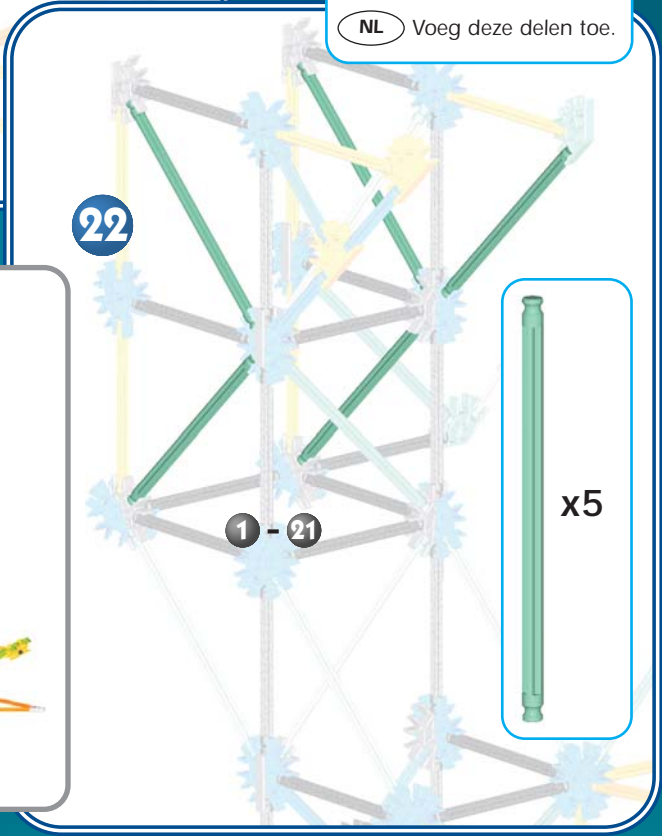

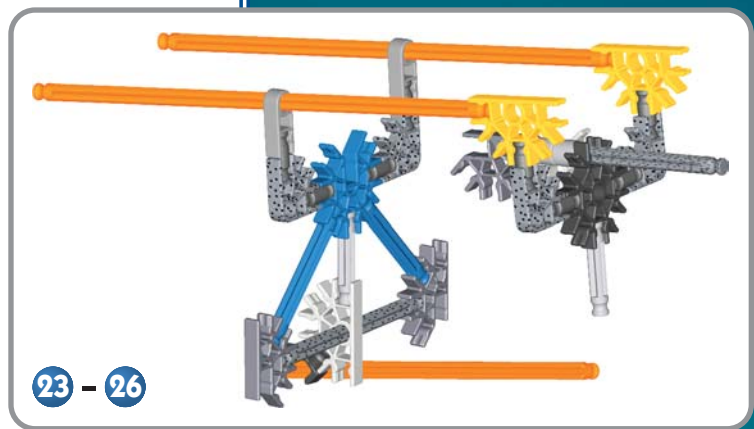
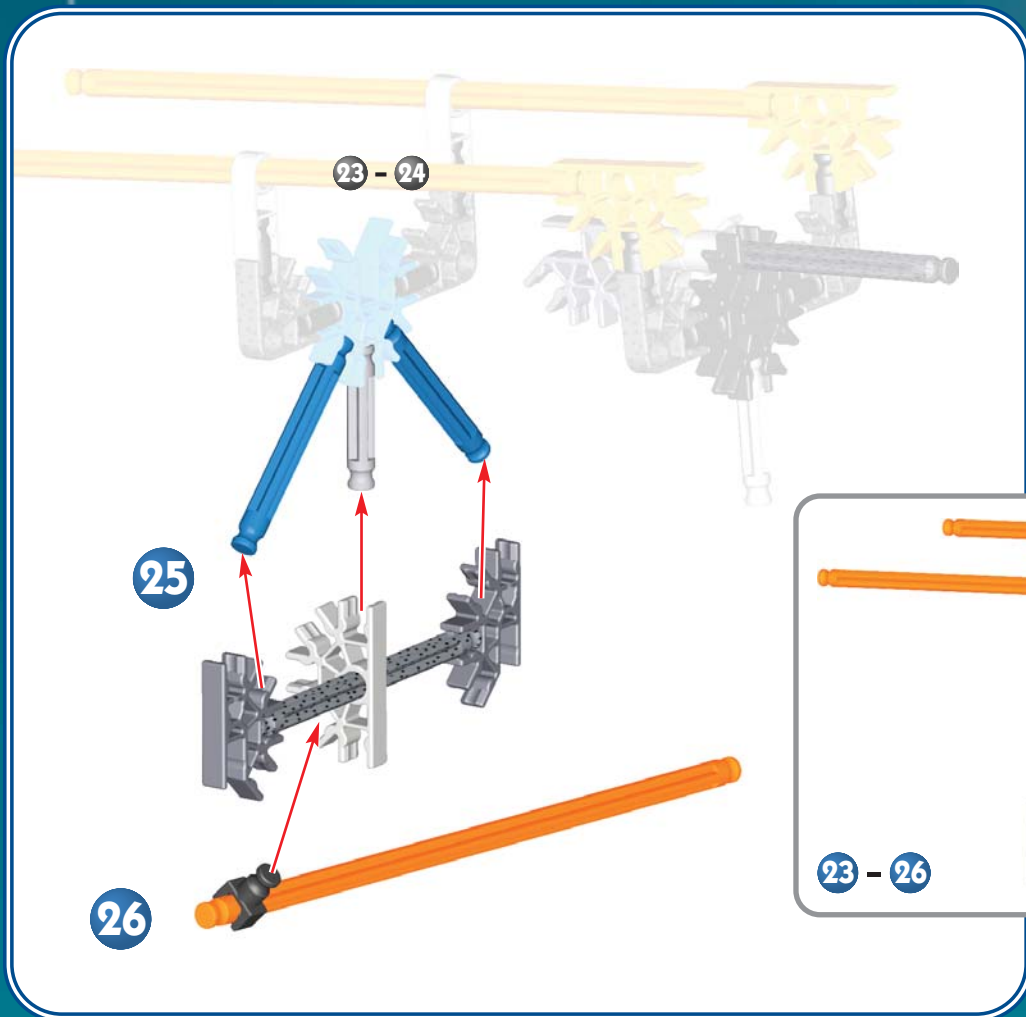

27

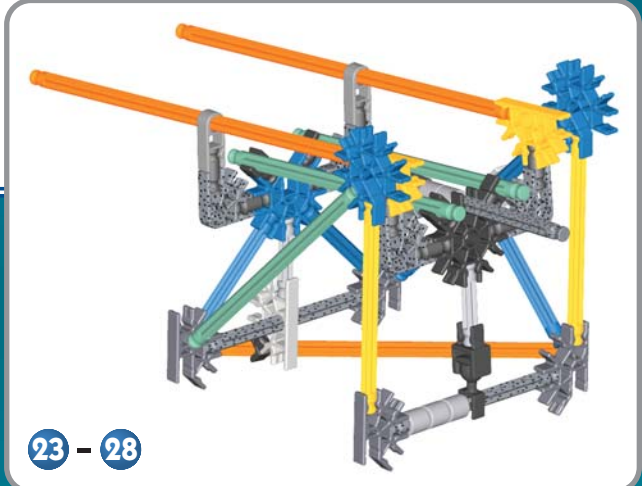
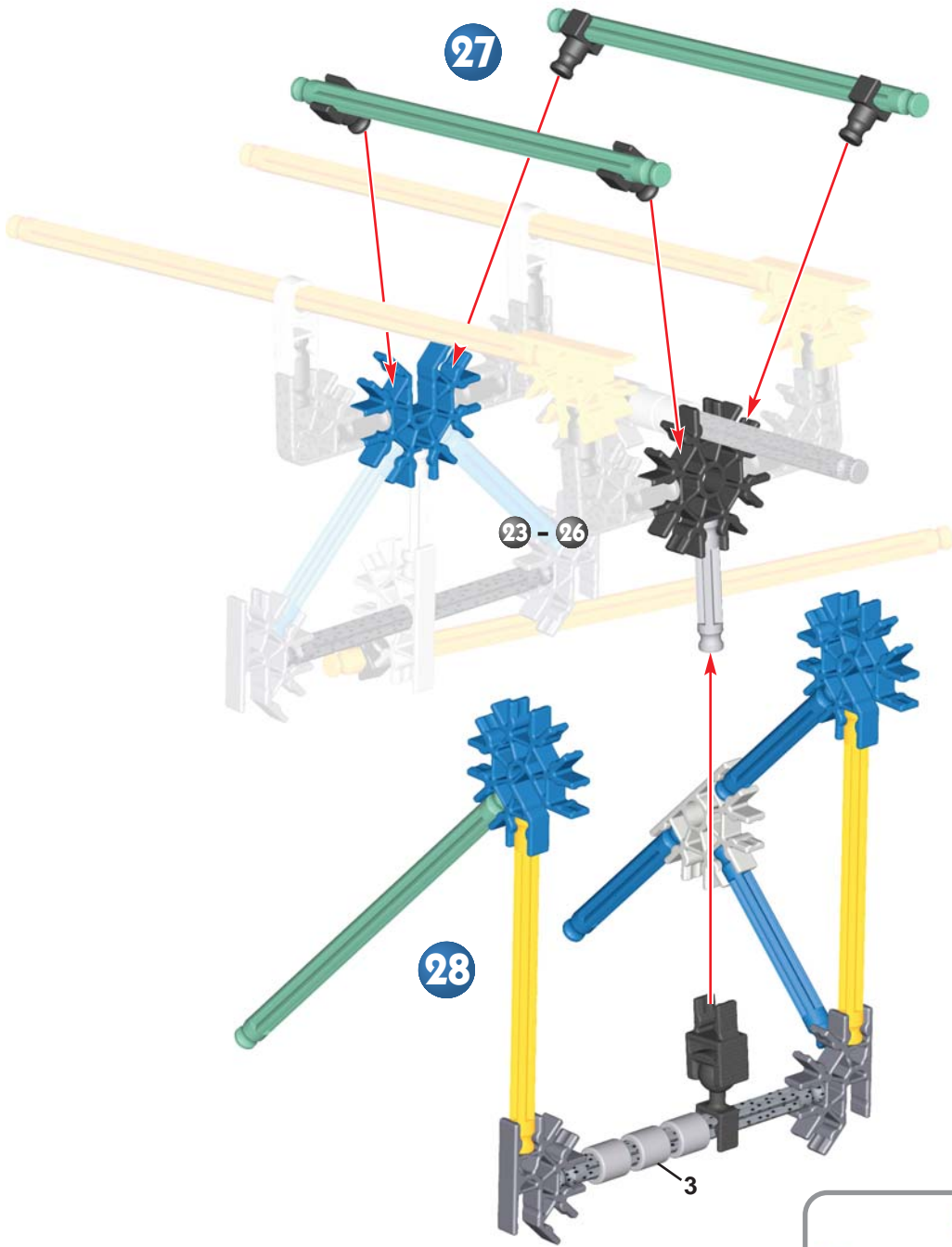

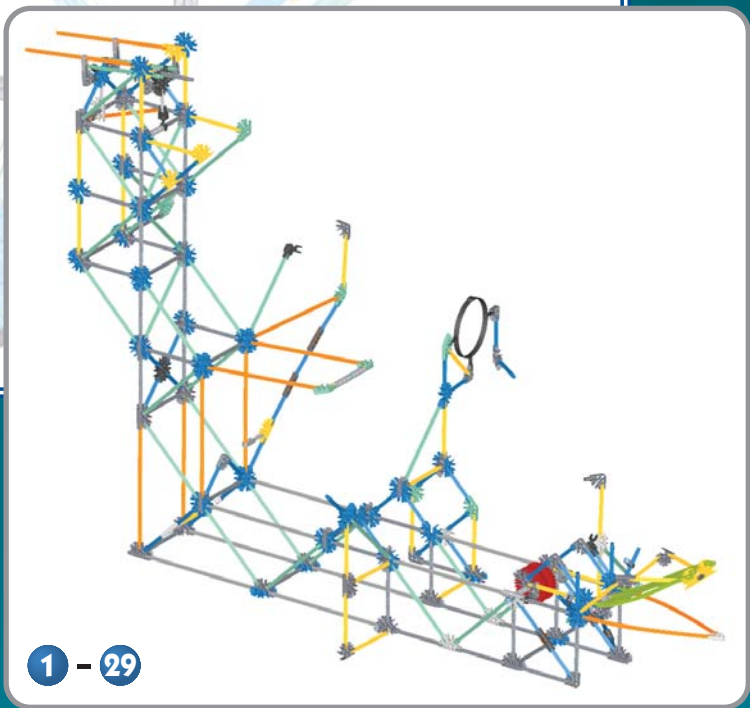
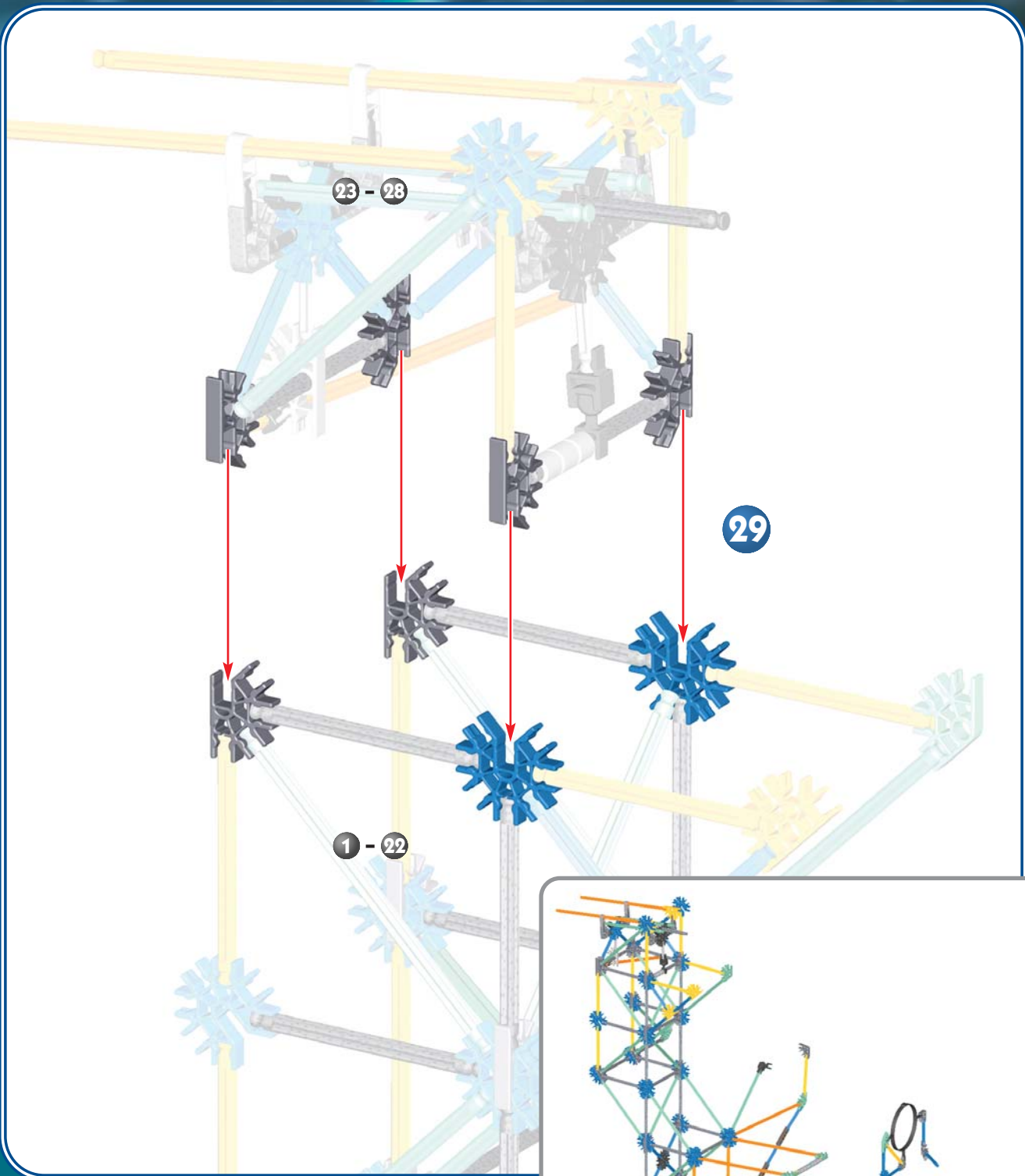

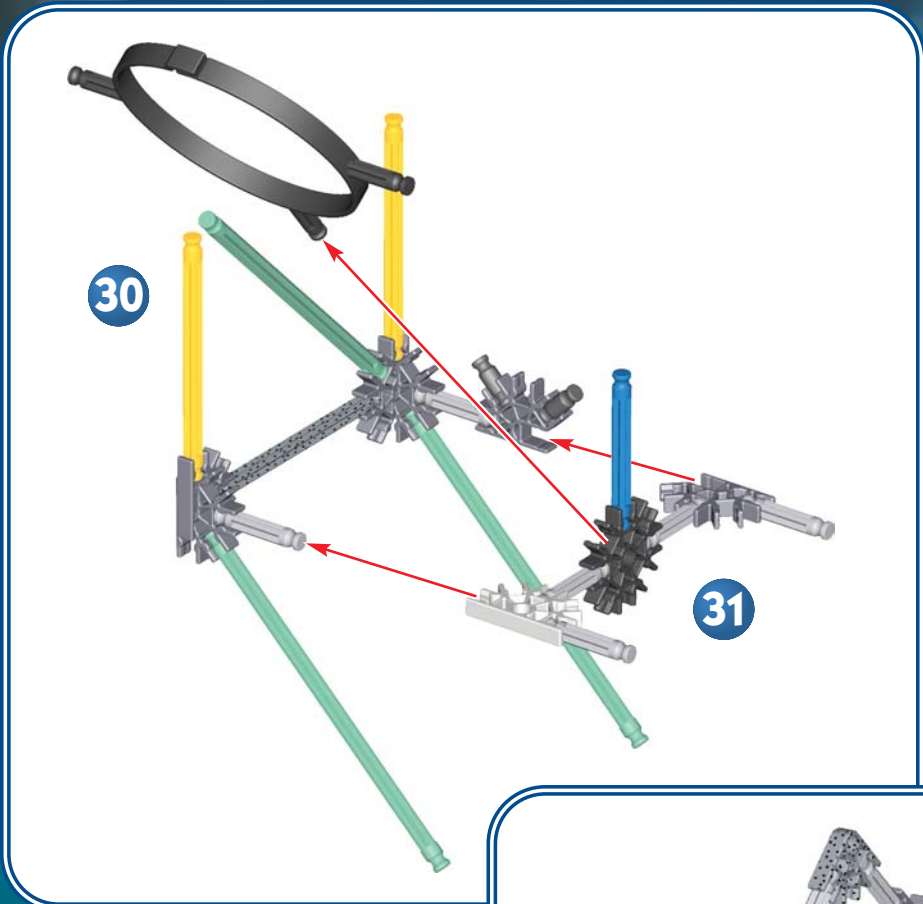

30

31

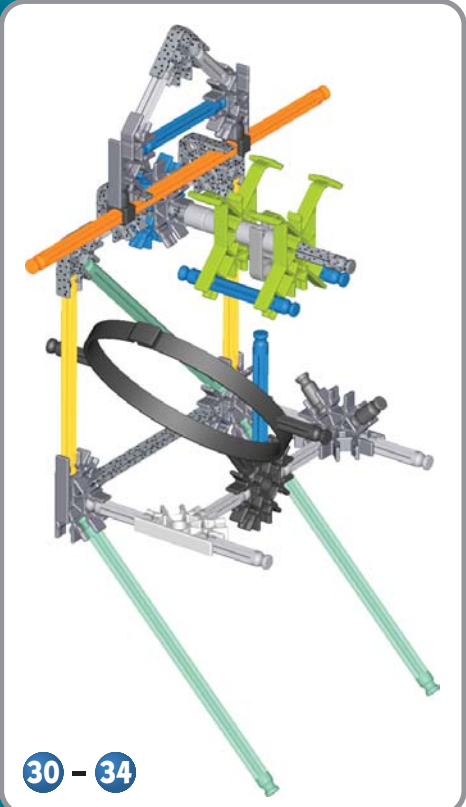

30 - 34

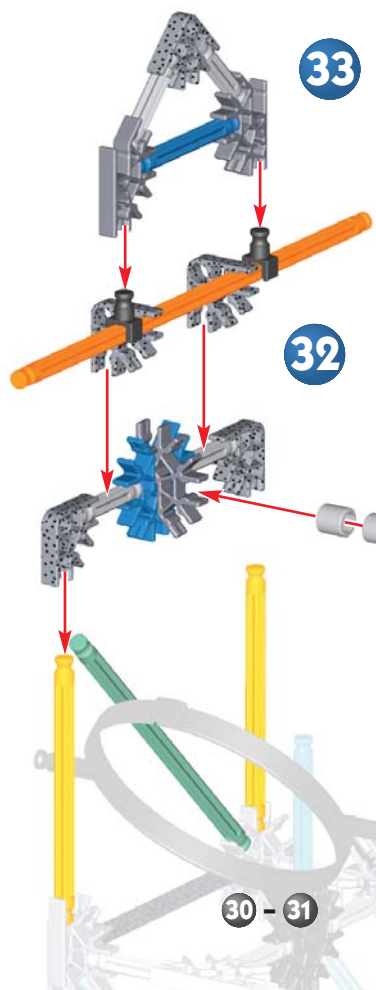

33

32

- ENG** Make sure the green Track Connectors spin freely.
- F** Veille à ce que les connecteurs verts du circuit puissent tourner librement.
- E** Asegúrate de que los Conectores verdes de la pista giran libremente.
- D** Achte unbedingt darauf, dass die grünen Trassenanschlüsse frei rotieren.
- NL** Verzeker je ervan dat de groene verbindingstukken voor het spoor vrij draaien.

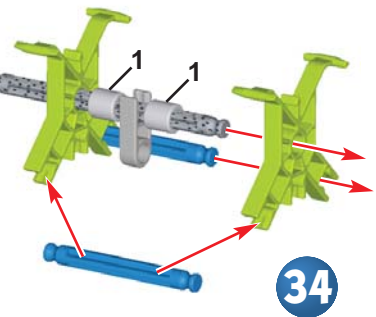

34

30 - 31

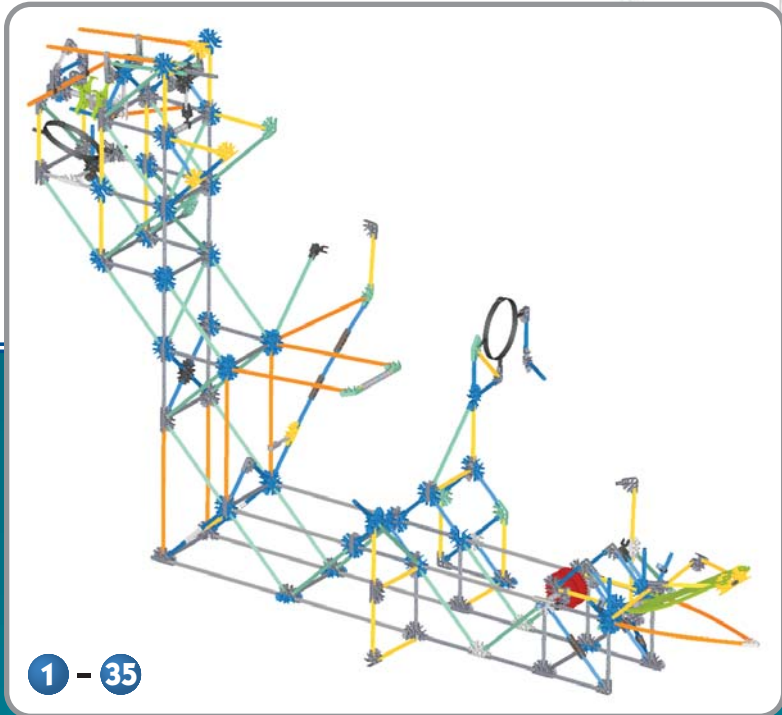
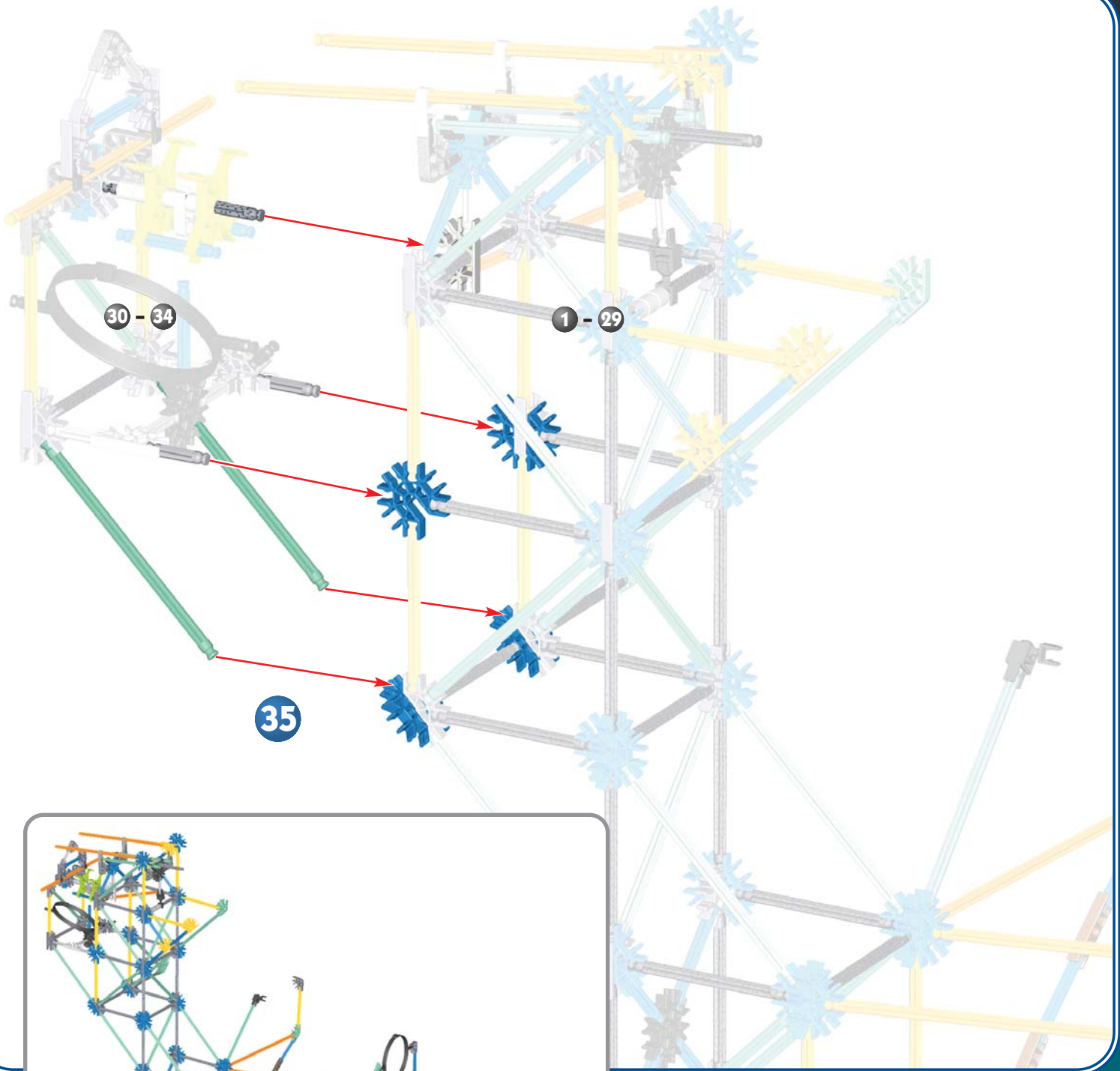

ENG Did you install 2 AA (or LR6) batteries?

F As-tu installé 2 piles AA (ou LR6)?

E ¿Instalaste 2 pilas AA (o LR6)?

D Hast du 2 Batterien der Baugröße AA (oder LR6) eingelegt?

NL Heb je er 2 AA (of LR6) batterijen ingestoken?

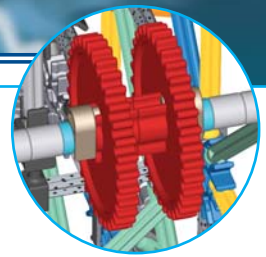
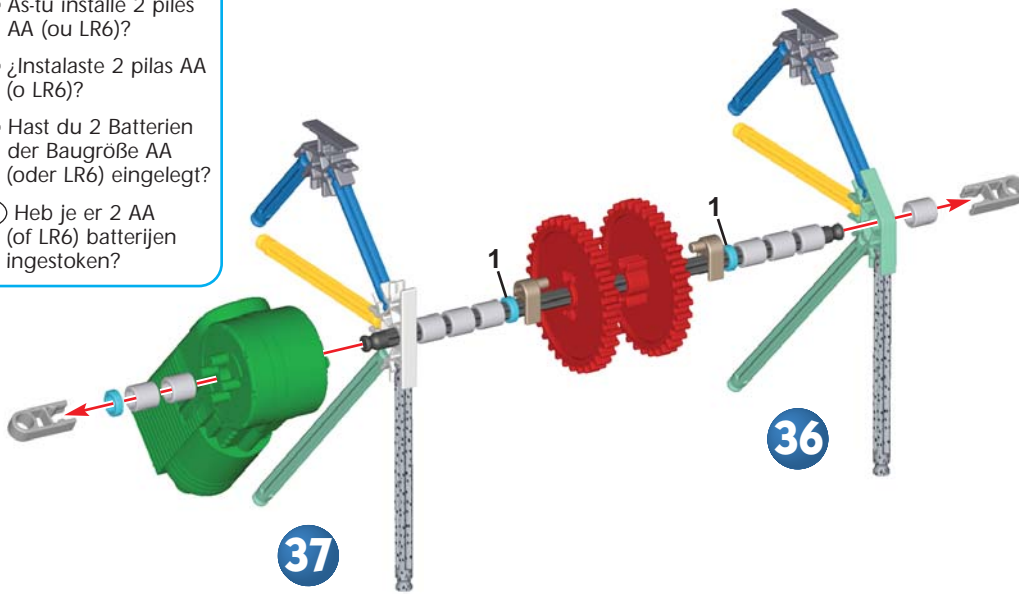

ENG Push Gears together tightly.

F Pousse bien les engrenages ensemble.

E Engancha firmemente los Engranajes.

D Achte darauf, dass das Getriebe fest verzahnt ist.

NL Duw de versnellingsmechanismen stevig in mekaar.

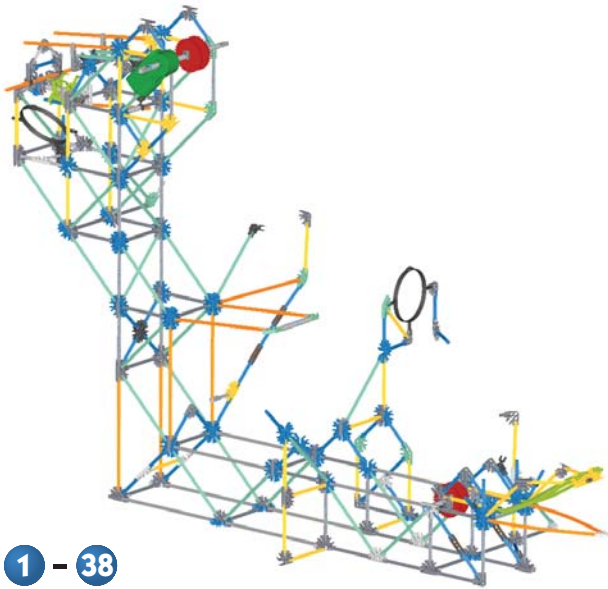

1 - 38

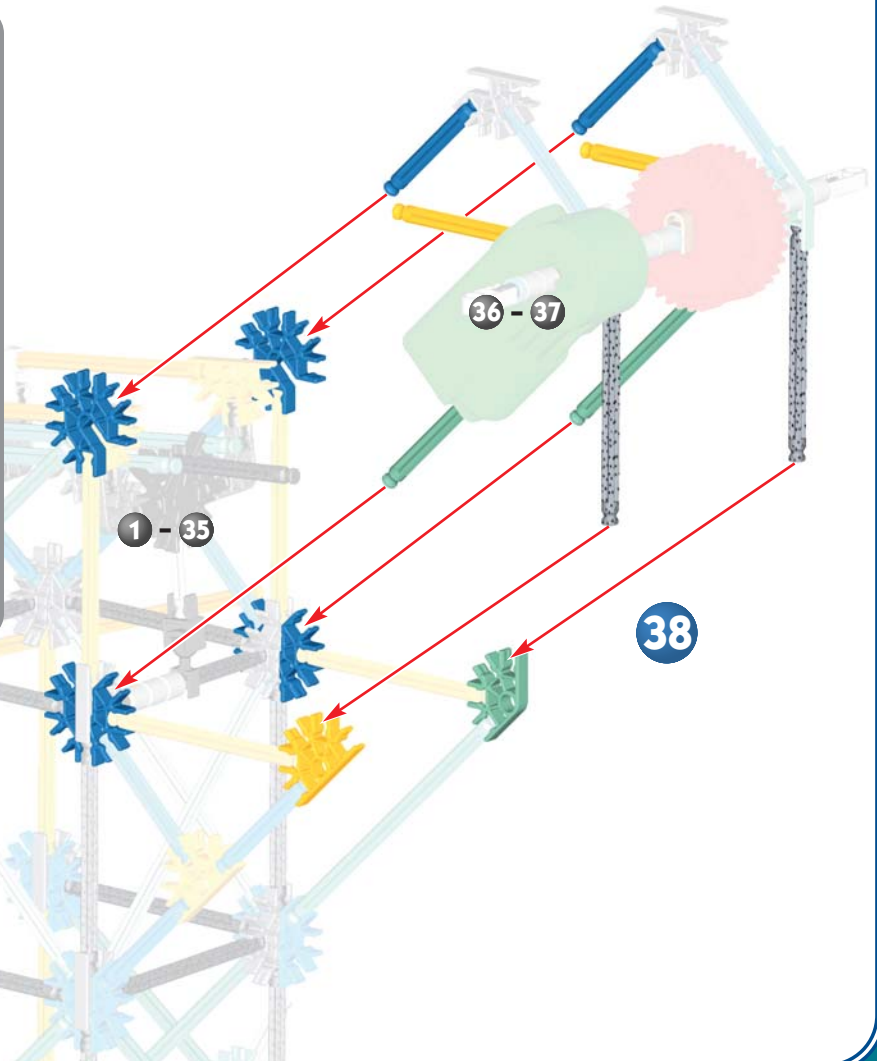

36 - 37

1 - 35

38

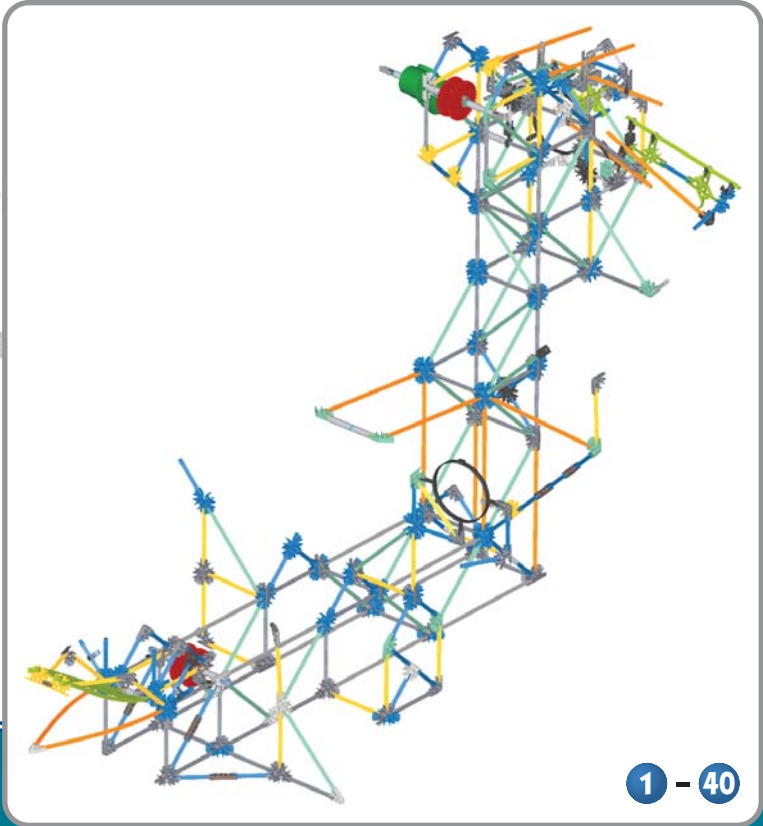
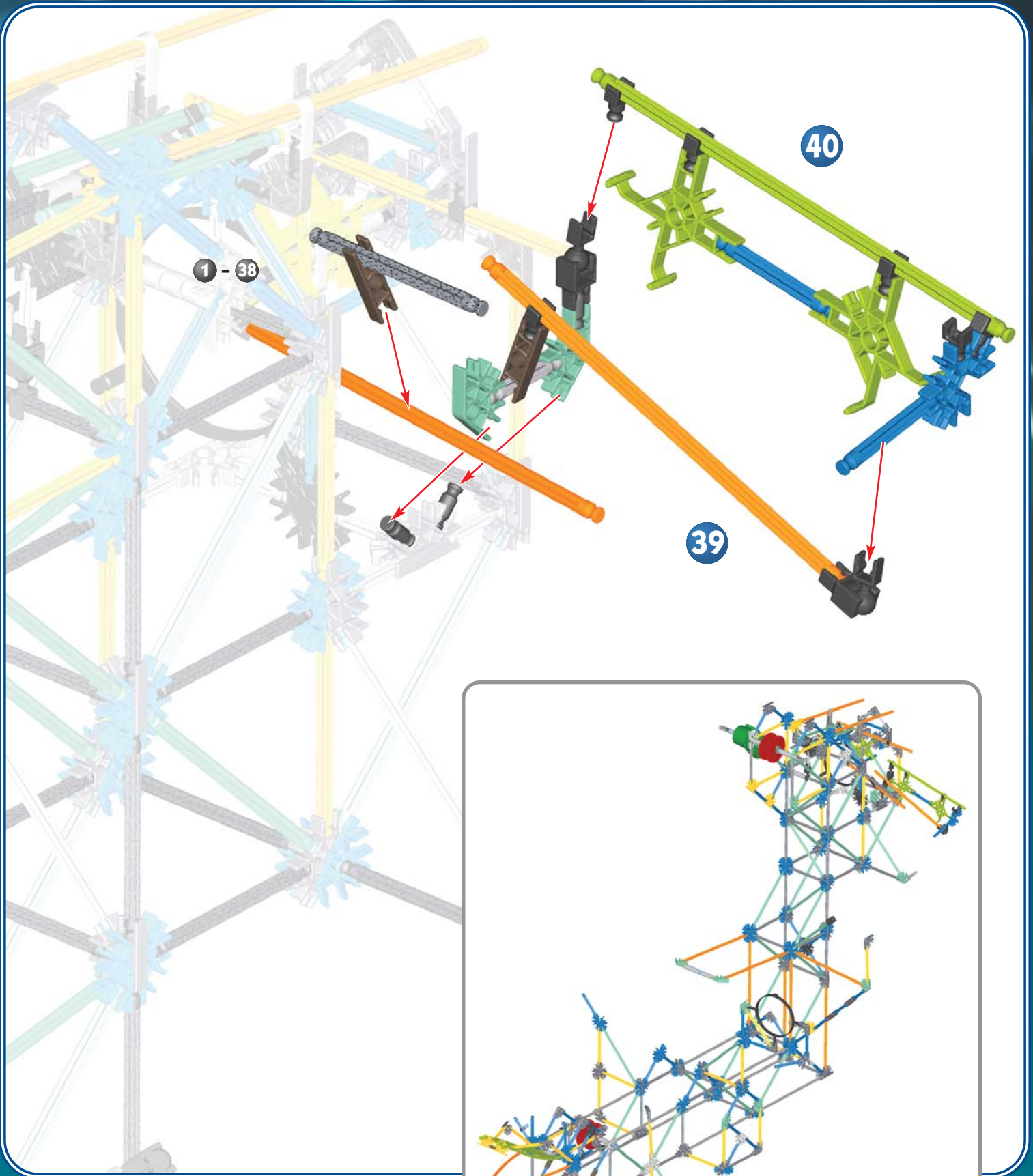

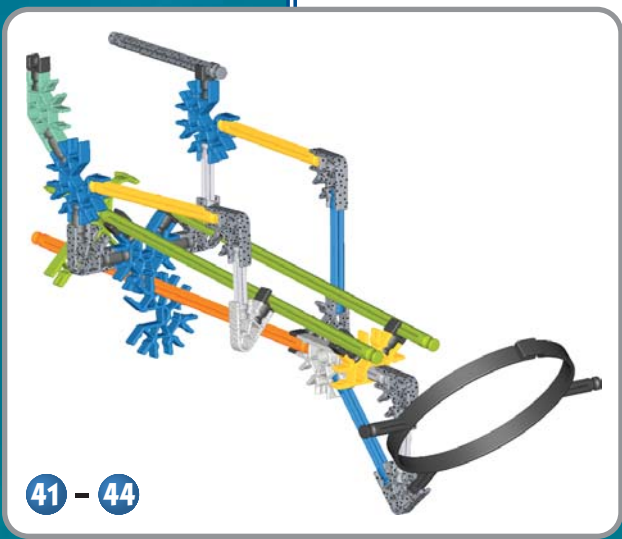
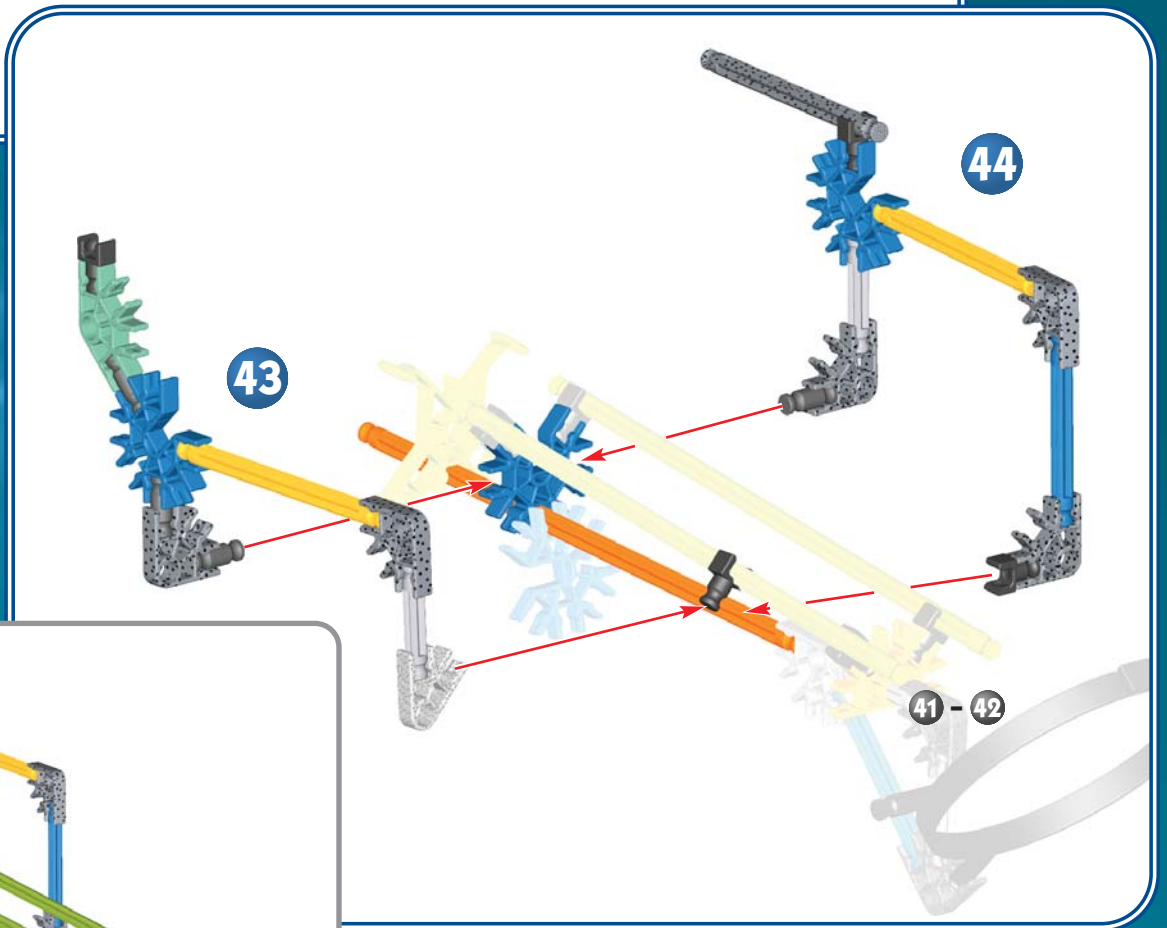
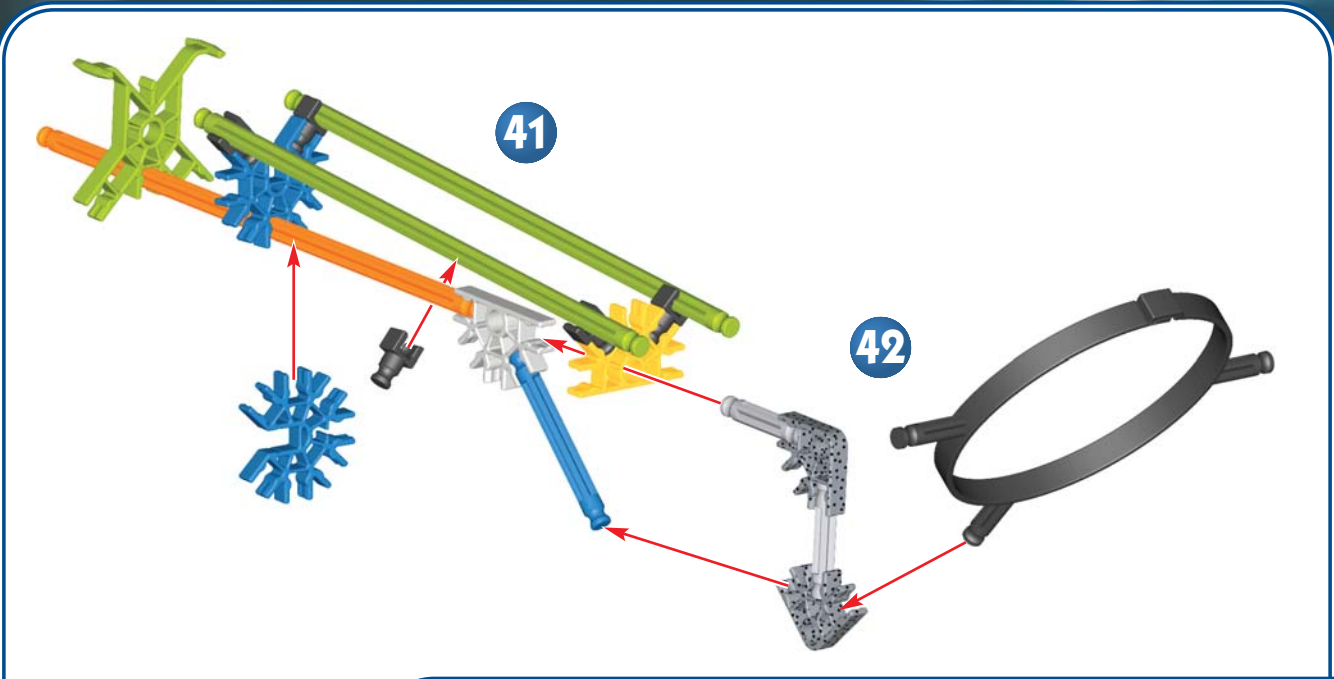

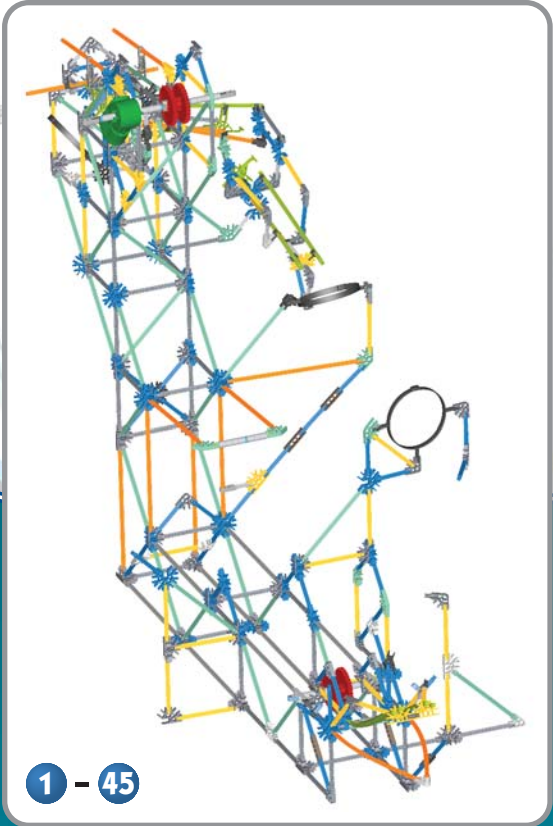
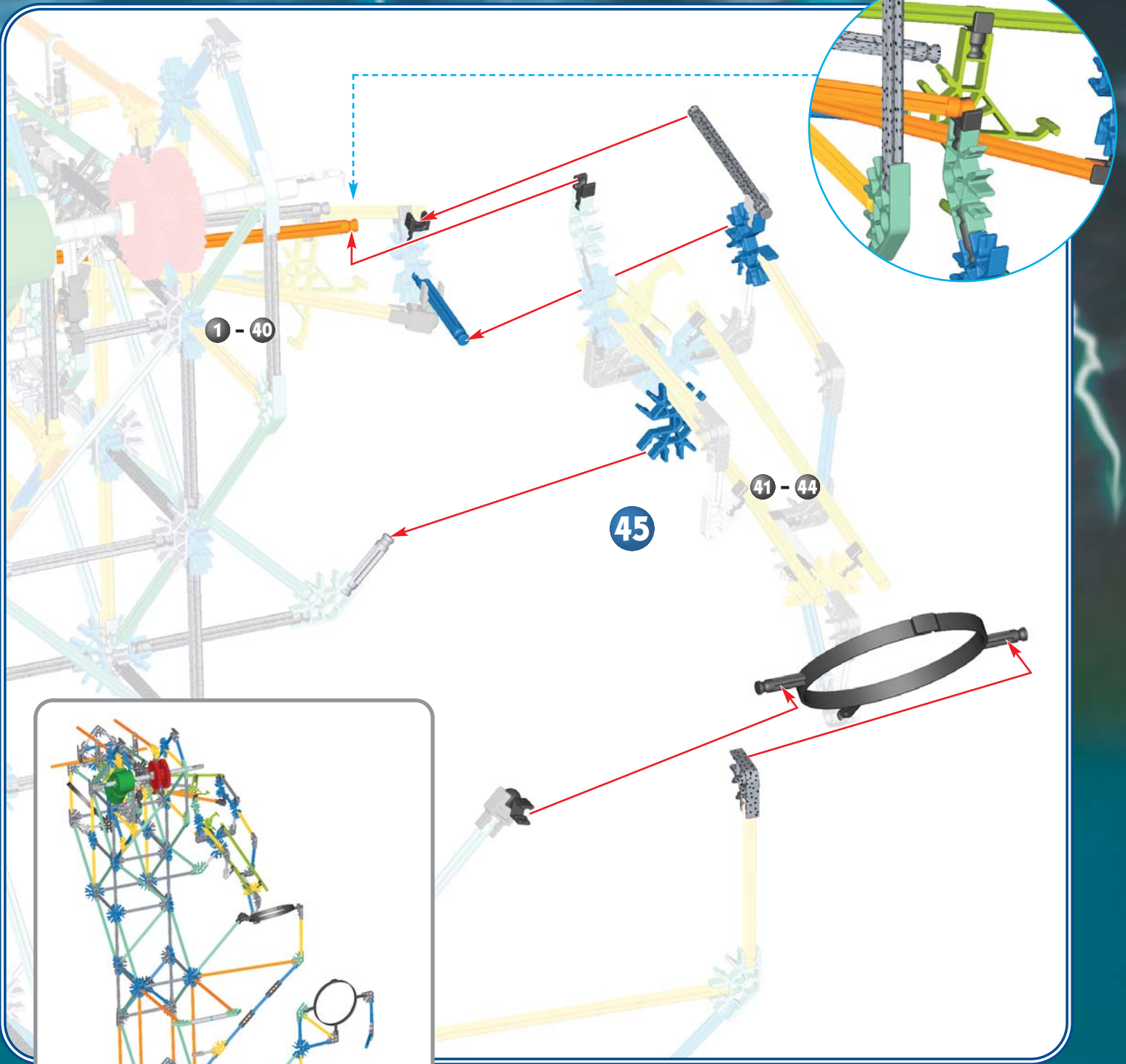

1 - 45

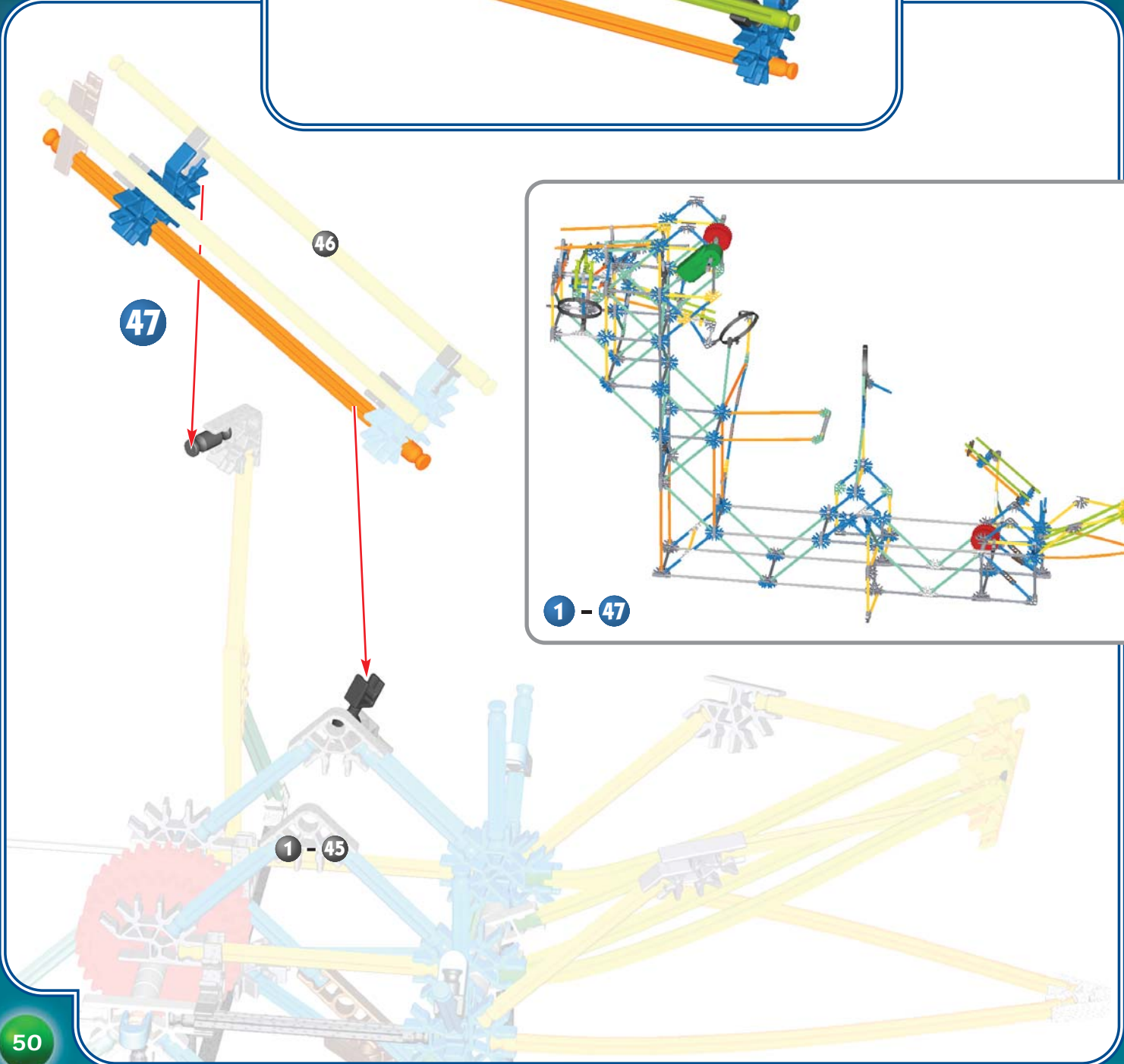
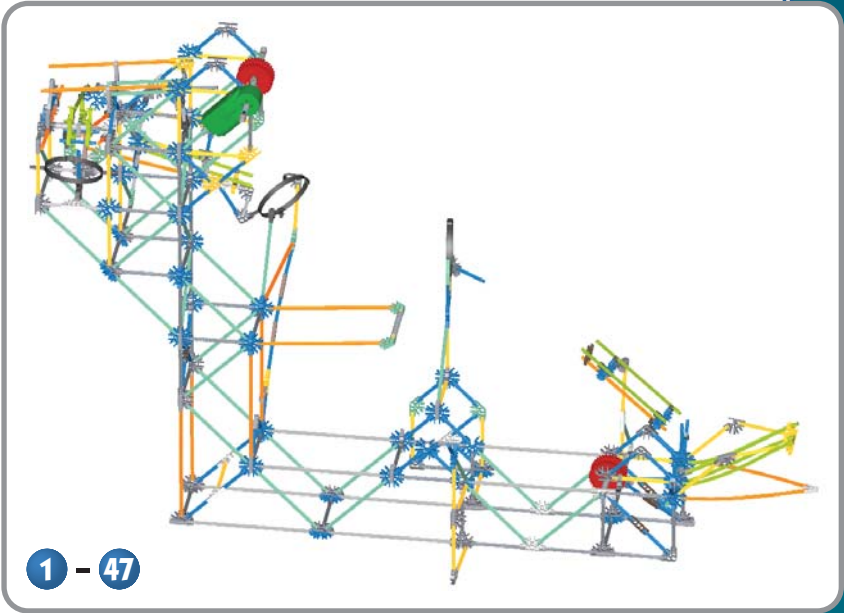
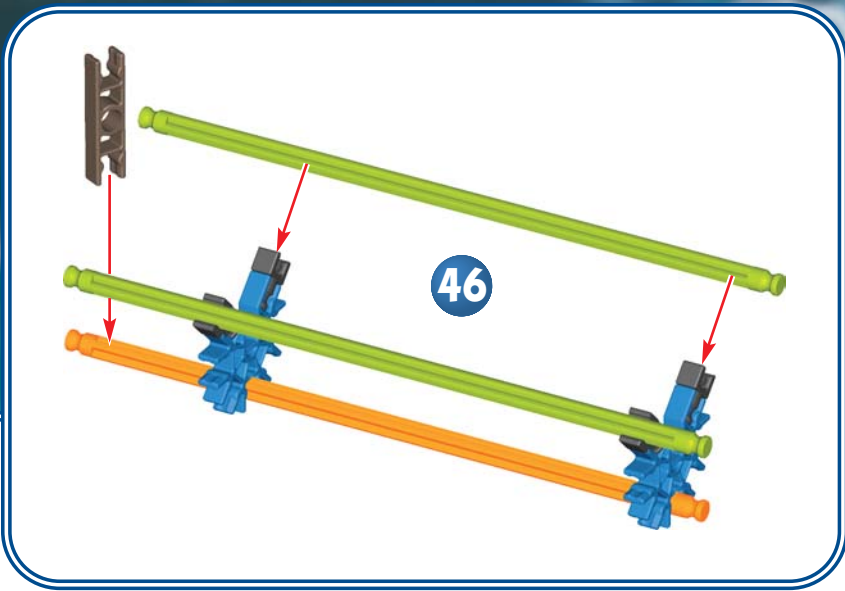

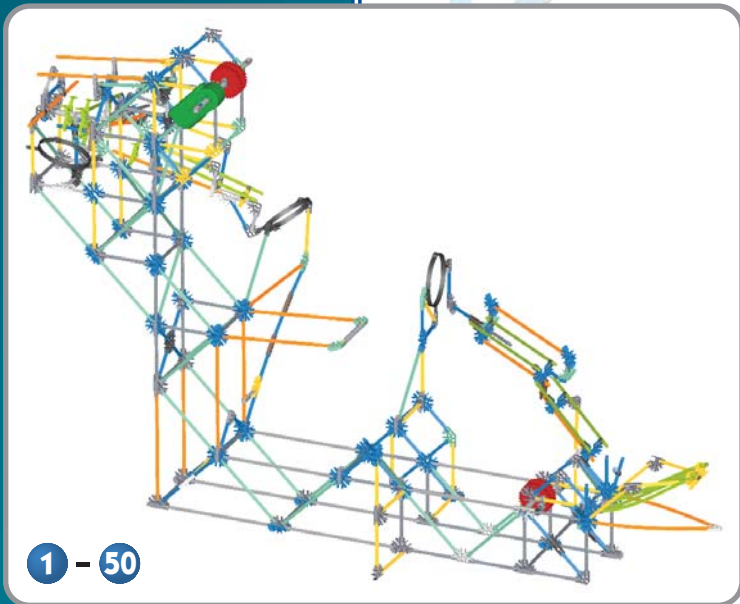
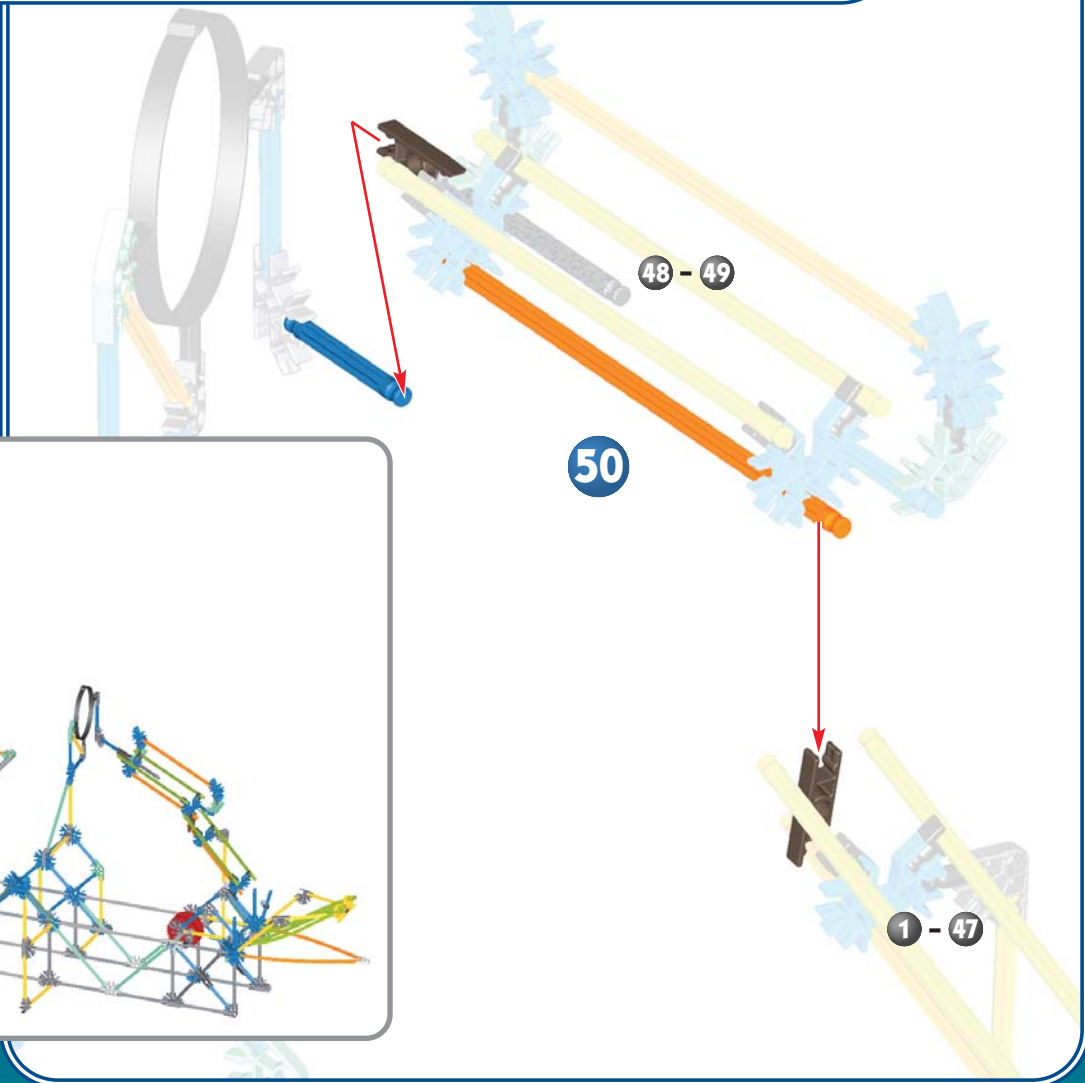
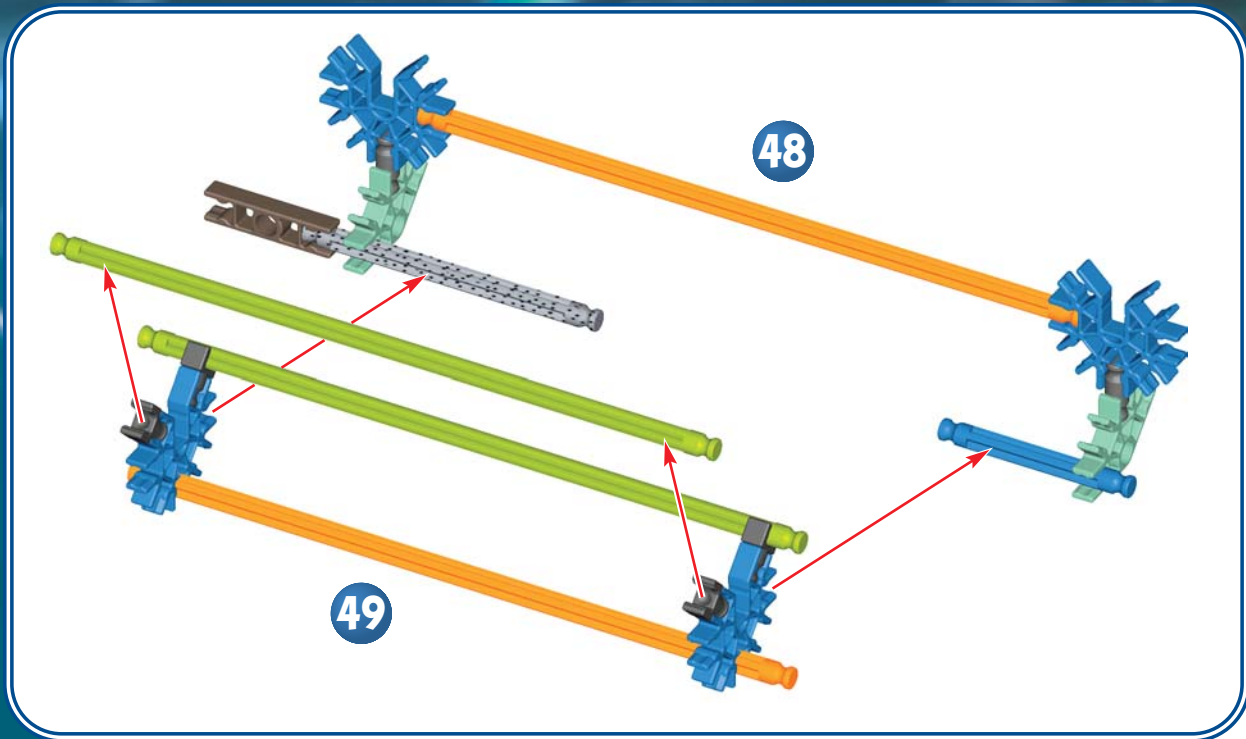

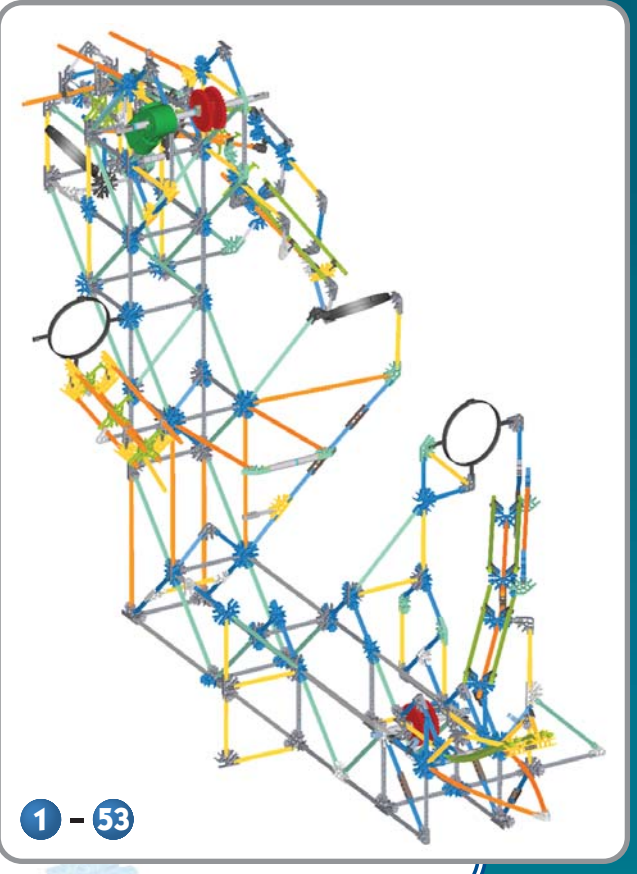
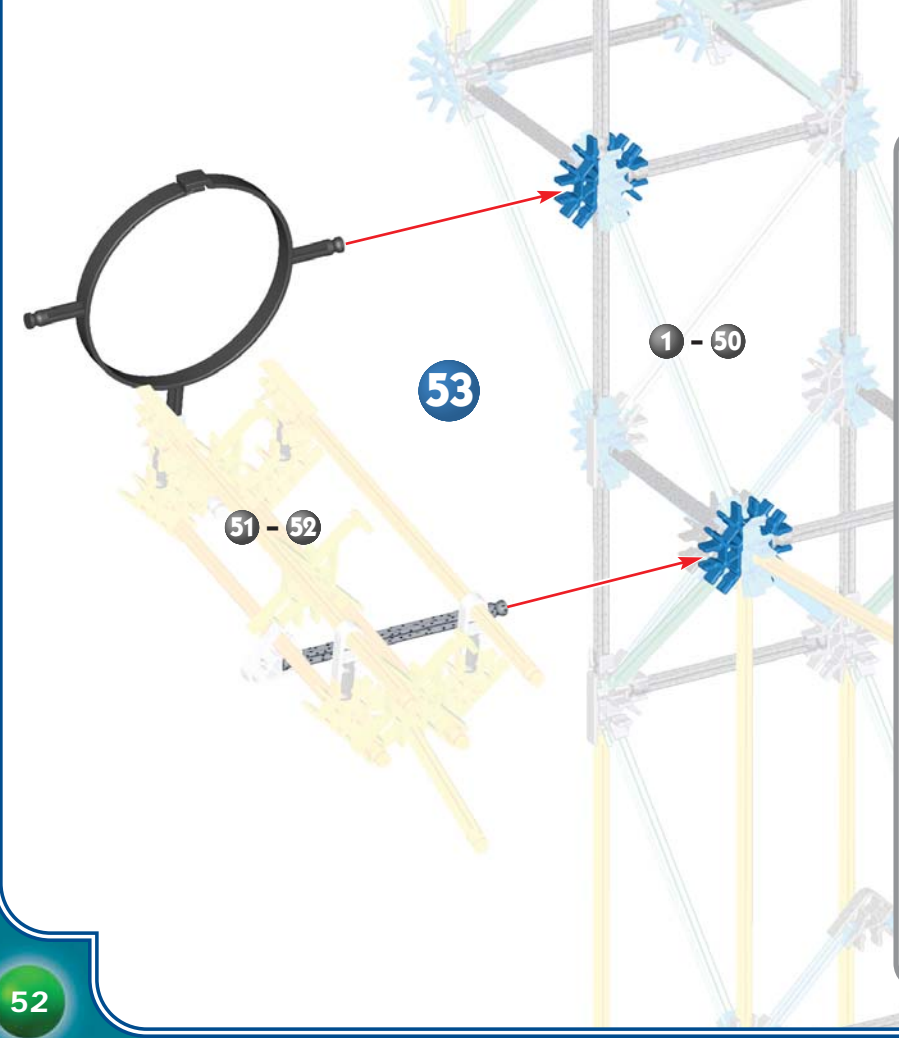
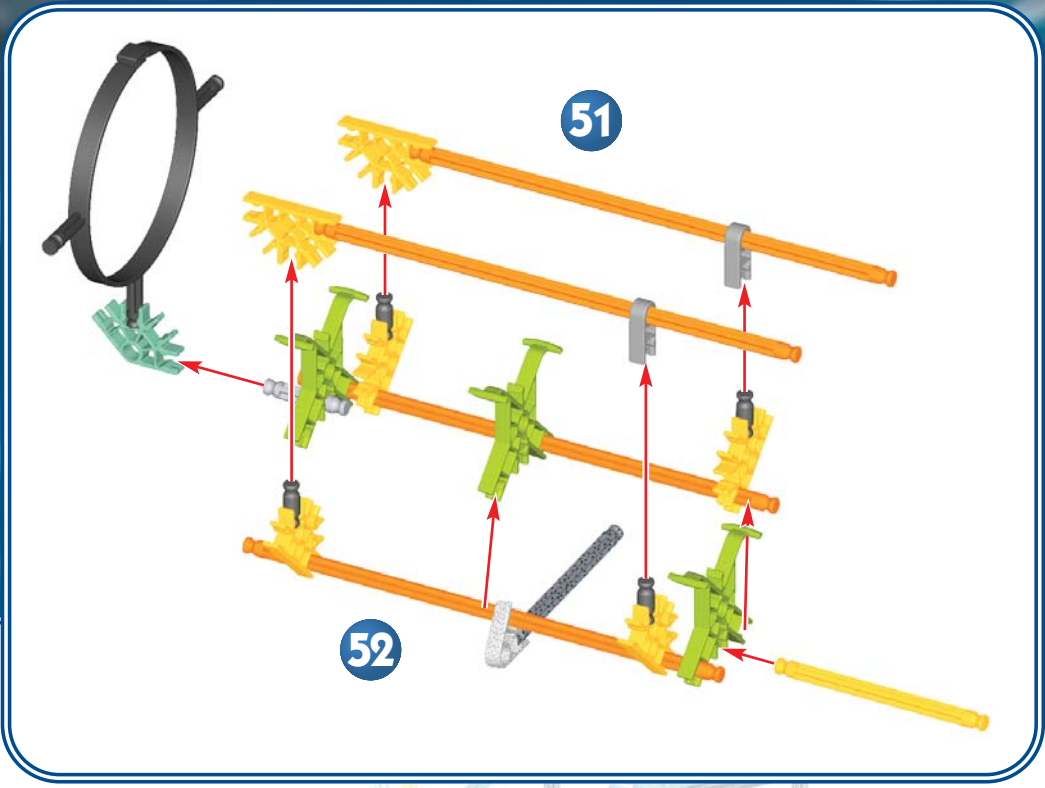

x3



ENG Number of Track Connectors.

F Nombre de connecteurs de voie.

E Número de Conectores del Carril.

D Zahl der Gleisanschlüsse.

NL Aantal koppelstukken van het spoor.

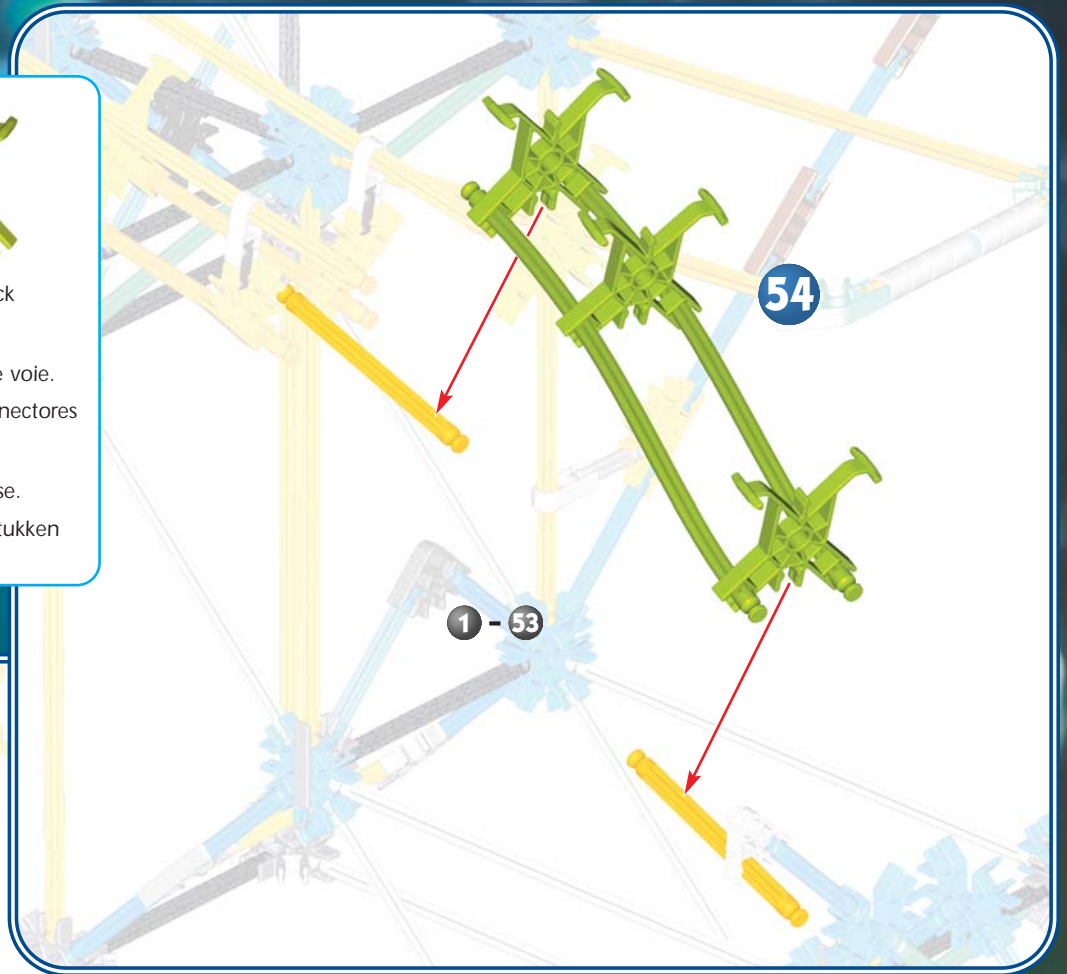

54

1 - 53

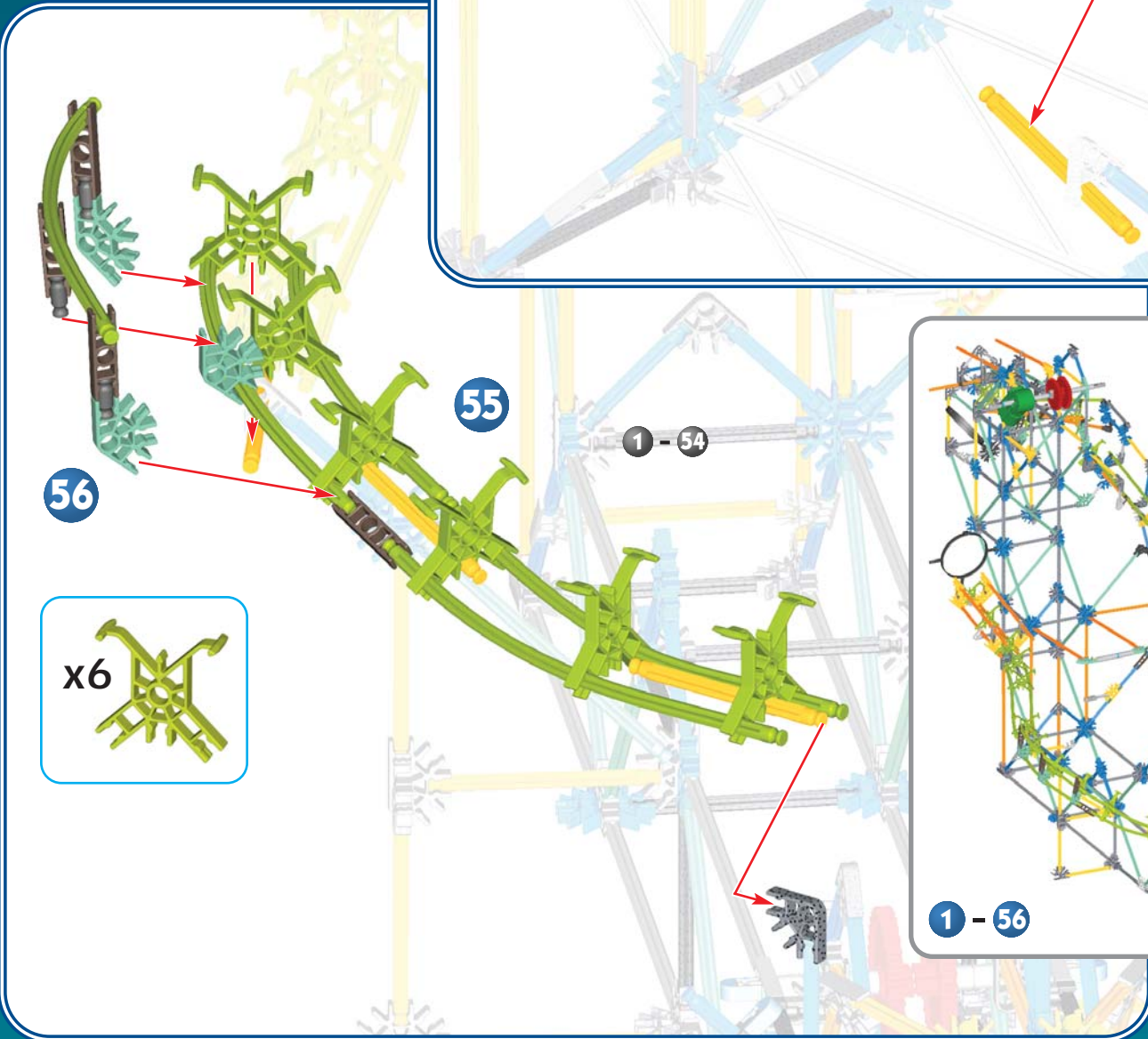

55

1 - 54

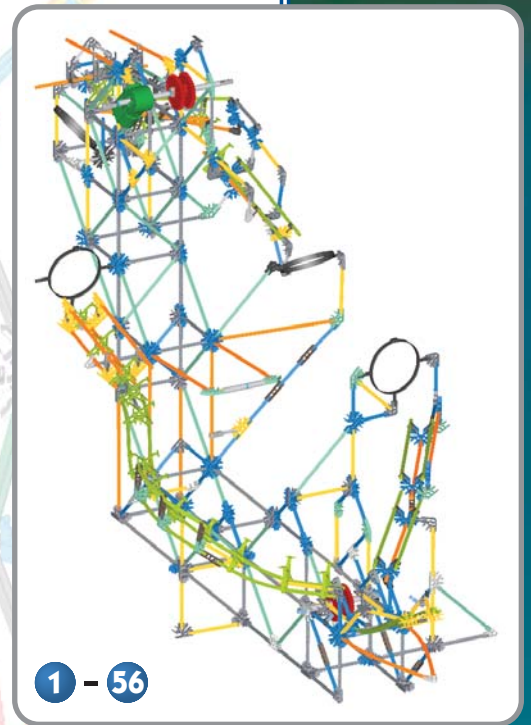

1 - 56

56

x6



- ENG** Start
- F** Départ
- E** Empieza
- D** Start hier
- NL** Begin

57

1 - 56

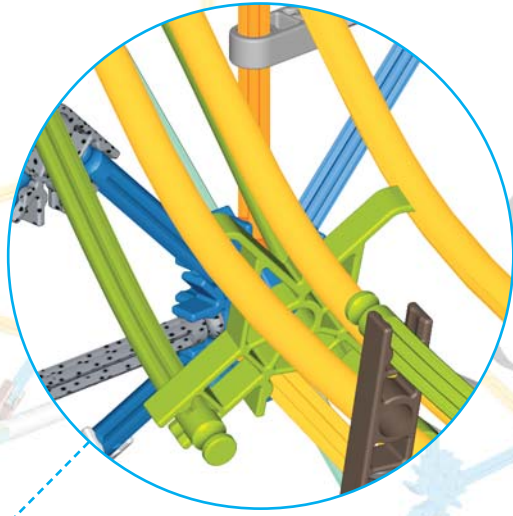



x78



x2

58

21



x2

8

59



x4

5

60

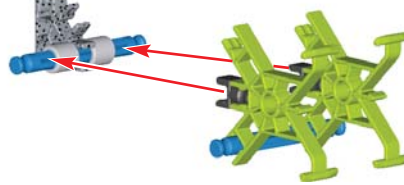

ENG IMPORTANT:
Attach Chain Links in
the same direction.

F IMPORTANT:
Attache les chaînon
dans le même sens.

E IMPORTANTE:
Conecta los Eslabones
de la Cadena en la
misma dirección.

D WICHTIG:
Befestige die
Kettenglieder immer in
die gleiche Richtung.

NL BELANGRIJK:
Maak de ketenschakels
vast in dezelfde richting.

ENG Do not connect yet.

F Ne fais pas encore la connexion.

E Todavía no la conectes.

D Halt! Noch nicht festmachen.

NL Nog niet aan mekaar koppelen.

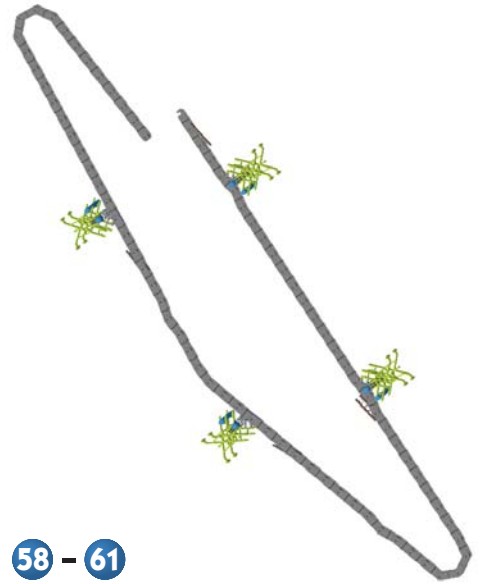
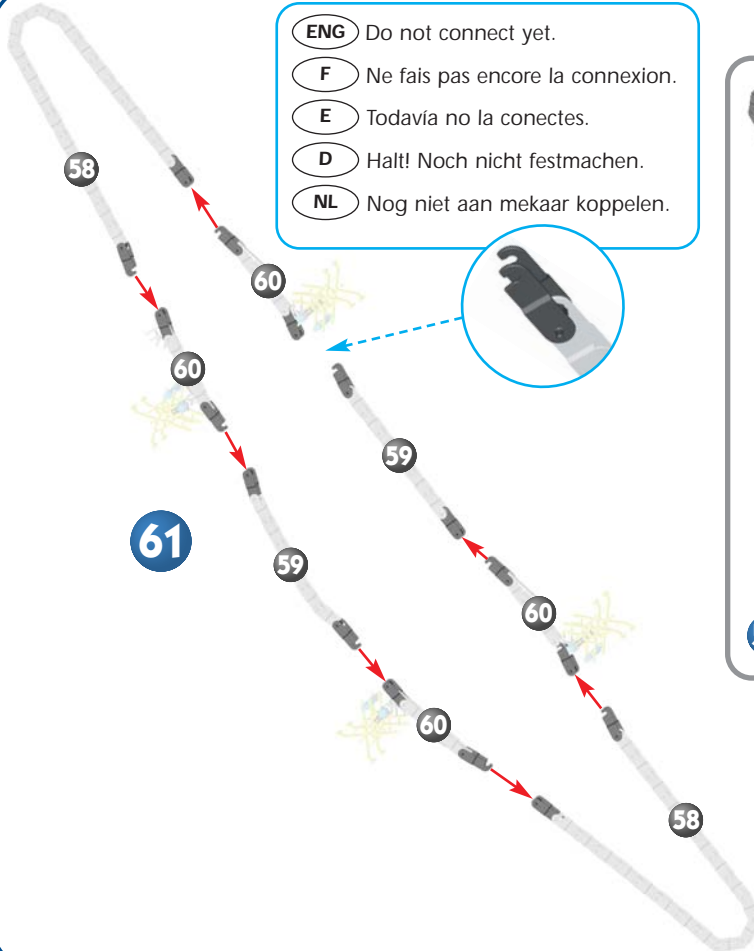

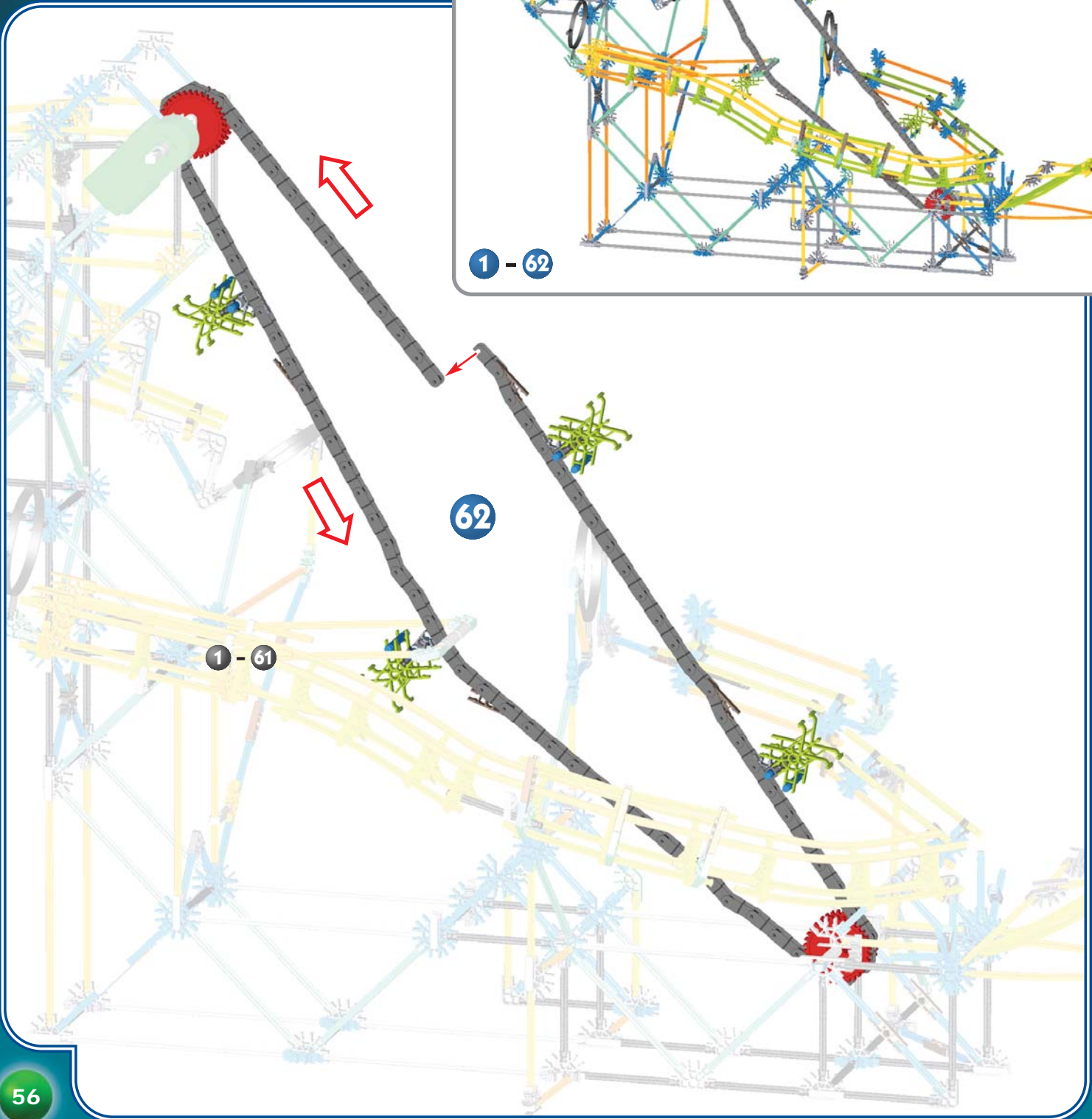

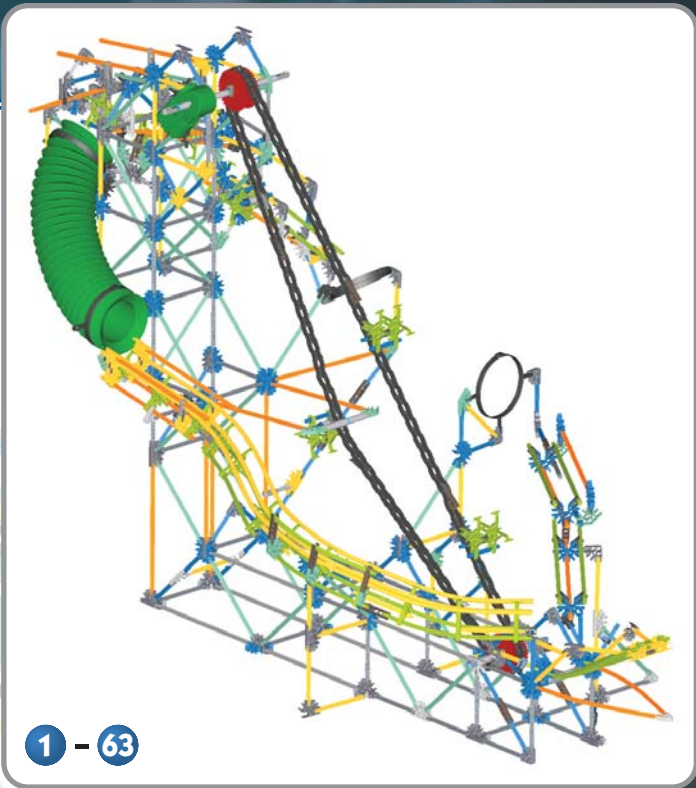

1 - 63

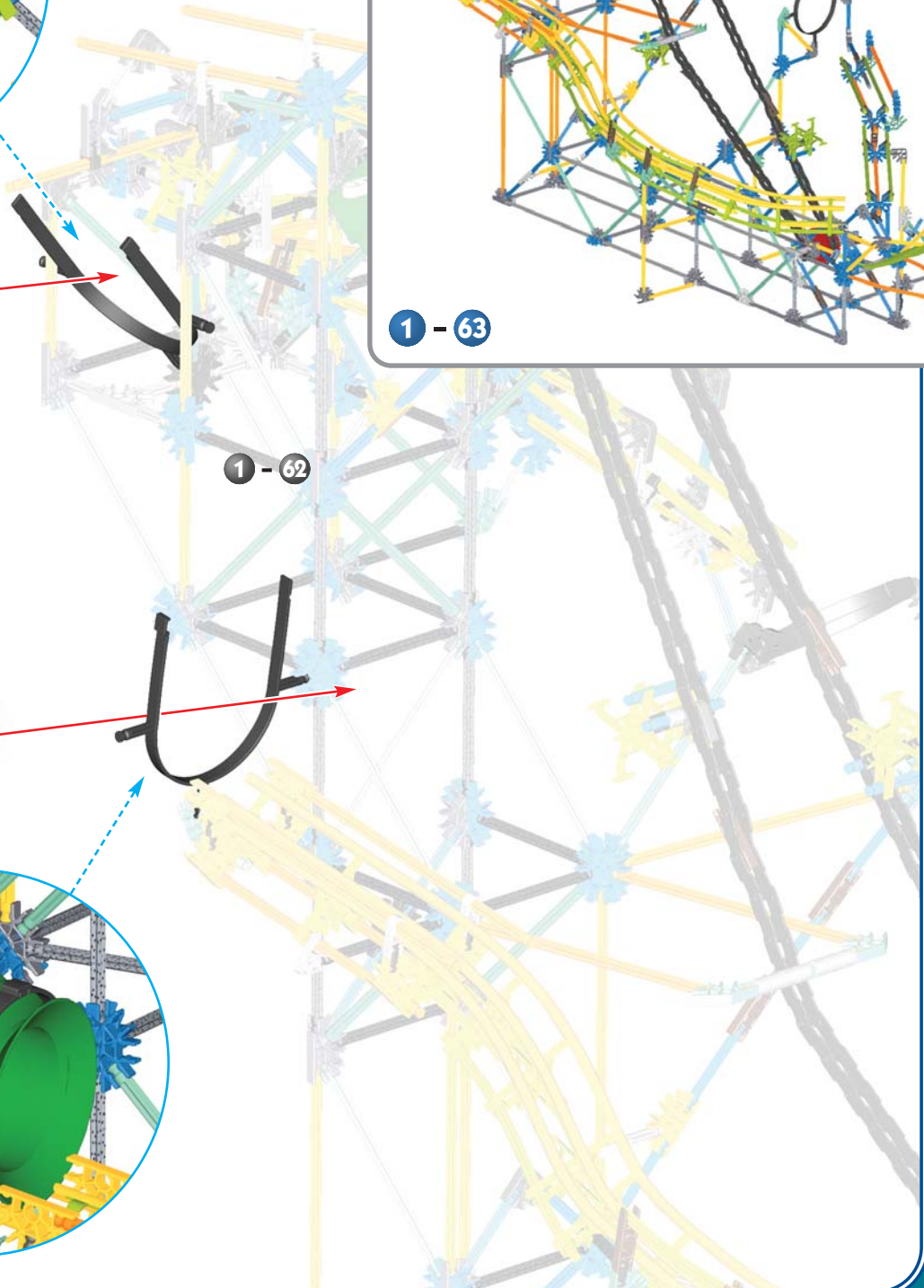
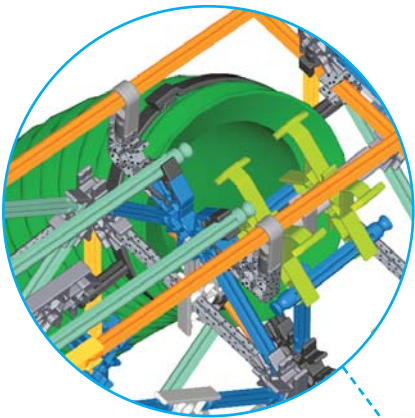

1 - 62

63

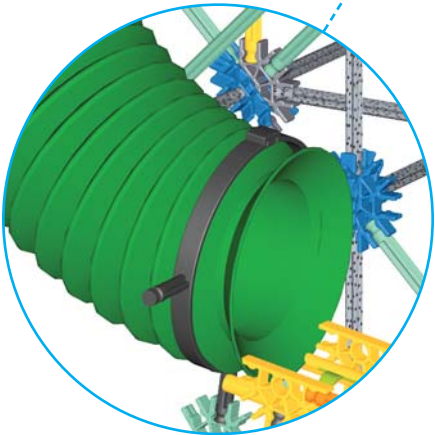

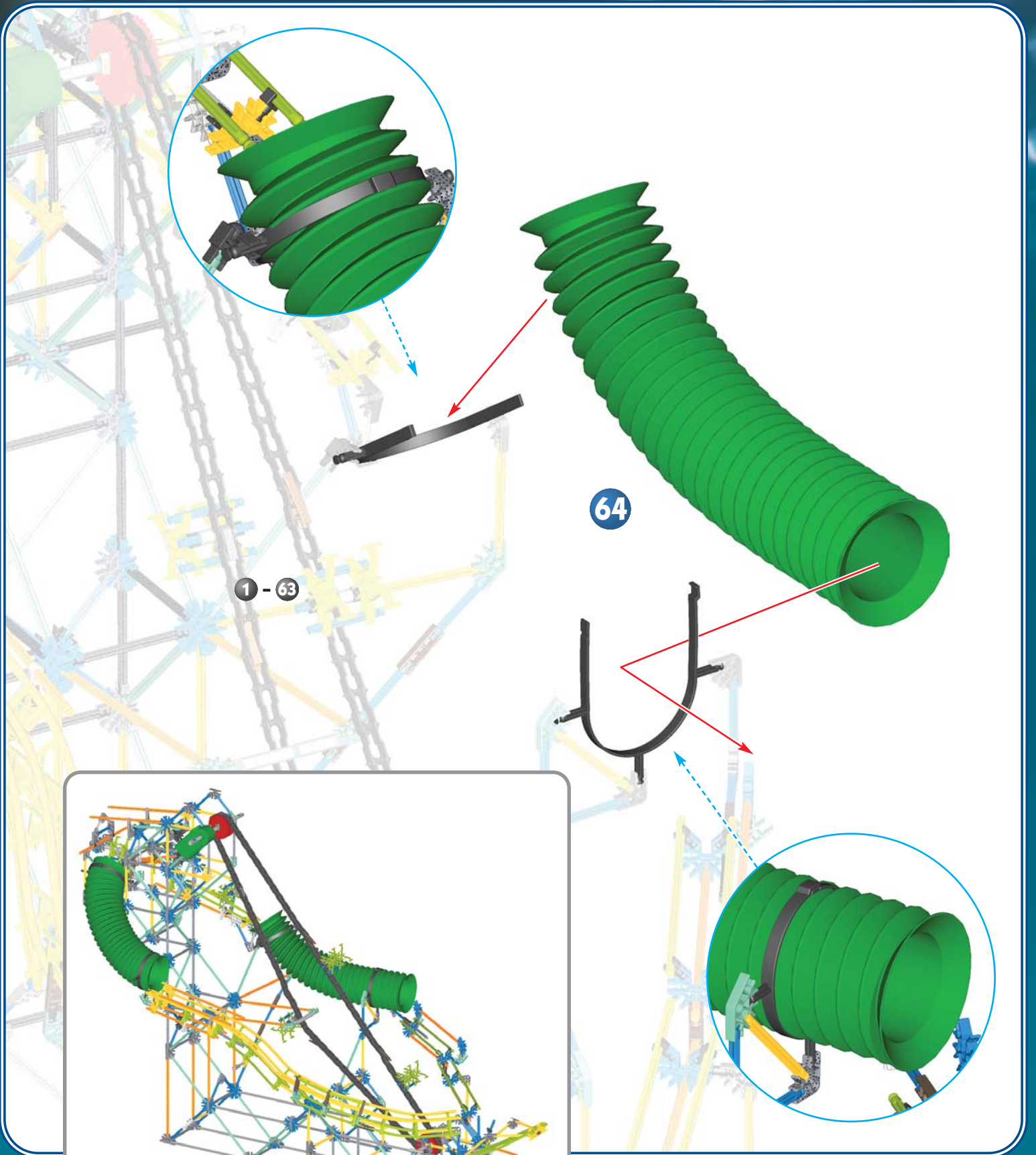

1 - 63

64

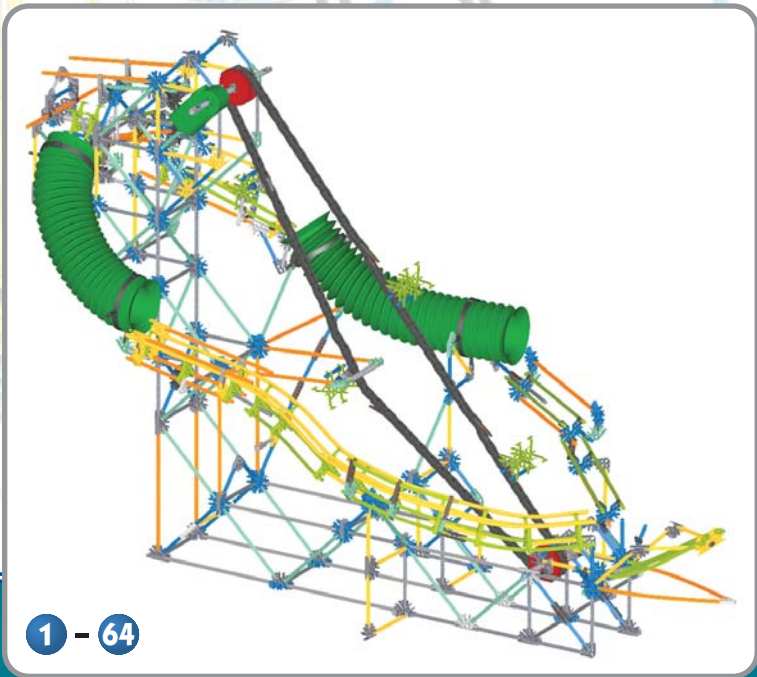

1 - 64

- ENG** Attach graphics.
- F** Attache les dessins graphiques.
- E** Fija los dibujos.
- D** Befestige die Grafikbilder.
- NL** Maak het grafisch kunstwerk vast.

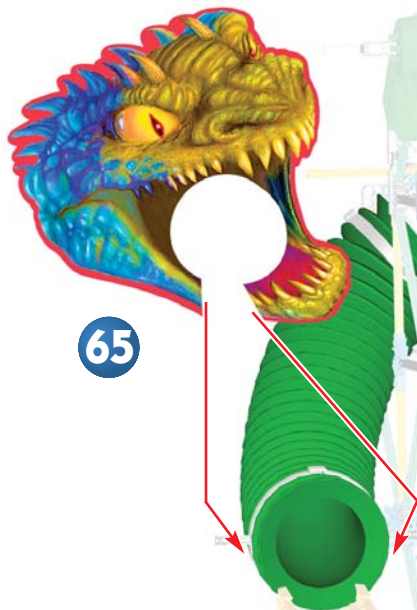

1 - 64

