

# K'NEX®

Imagine • Build • Play®

9+

## LAVA LAUNCH COASTER™

**MOTORIZED LAUNCHER\***  
**LANCE-MISSILES**  
**MOTORISÉ**

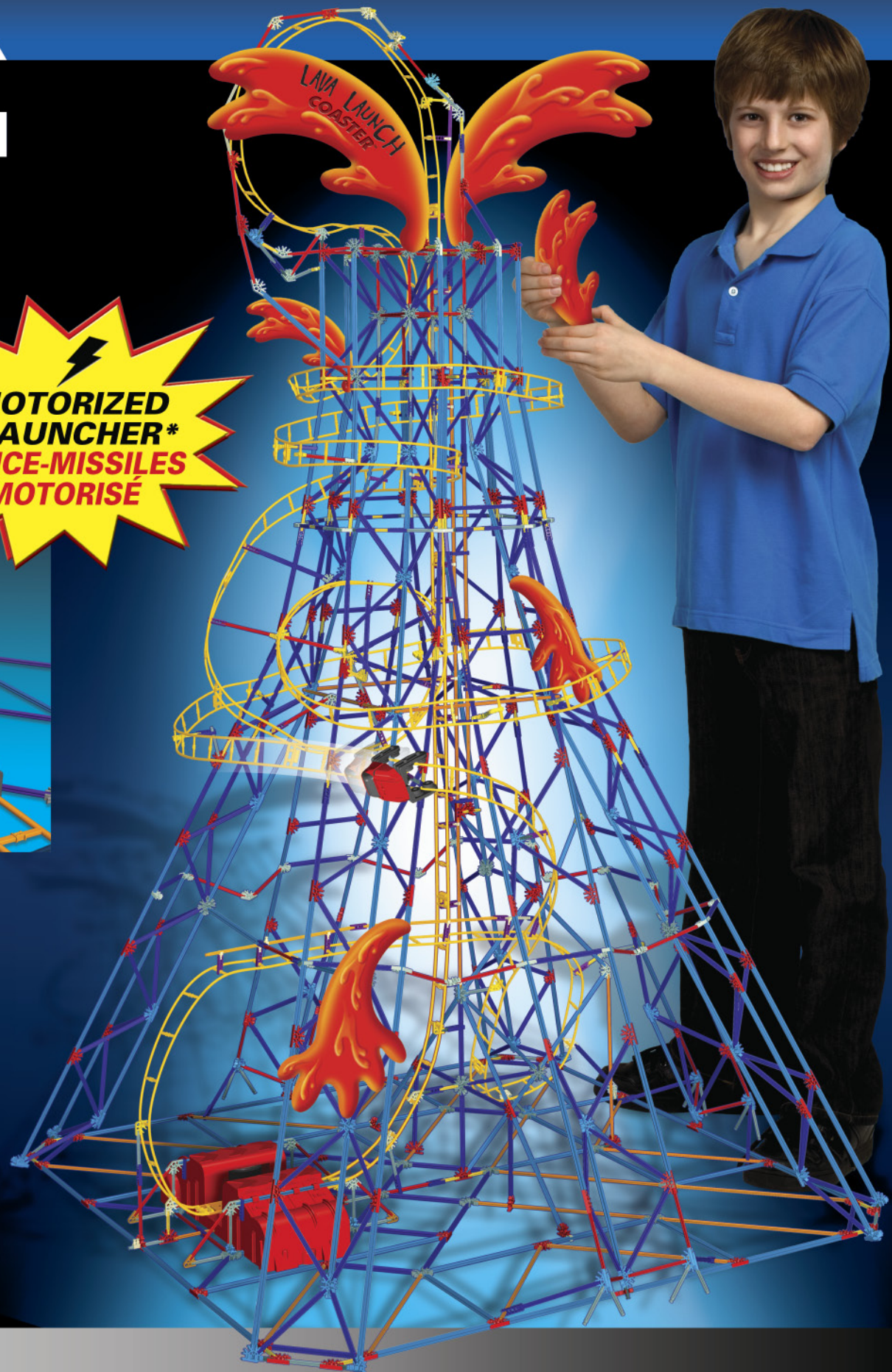
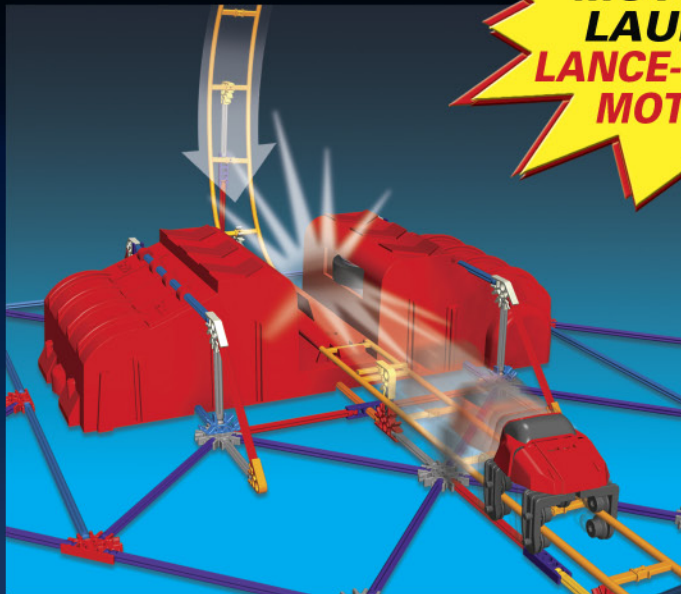

### WARNING:

CHOKING HAZARD - Small parts.  
Not for children under 3 years.



### AVERTISSEMENT:

DANGER D'ÉTOUFFEMENT - Pièces de petite taille.  
Ne pas donner aux enfants de moins de 3 ans.

# CONTENTS

**LAVA LAUNCH COASTER . . . 4**  
**Attaching Graphic Panels . . . . . 64**  
**Attaching Coaster Car. . . . . 66**  
**Tips & Troubleshooting. . . . . 66**  
**BUILDING IDEA . . . . . 68**  
**Languages . . . . . 69**

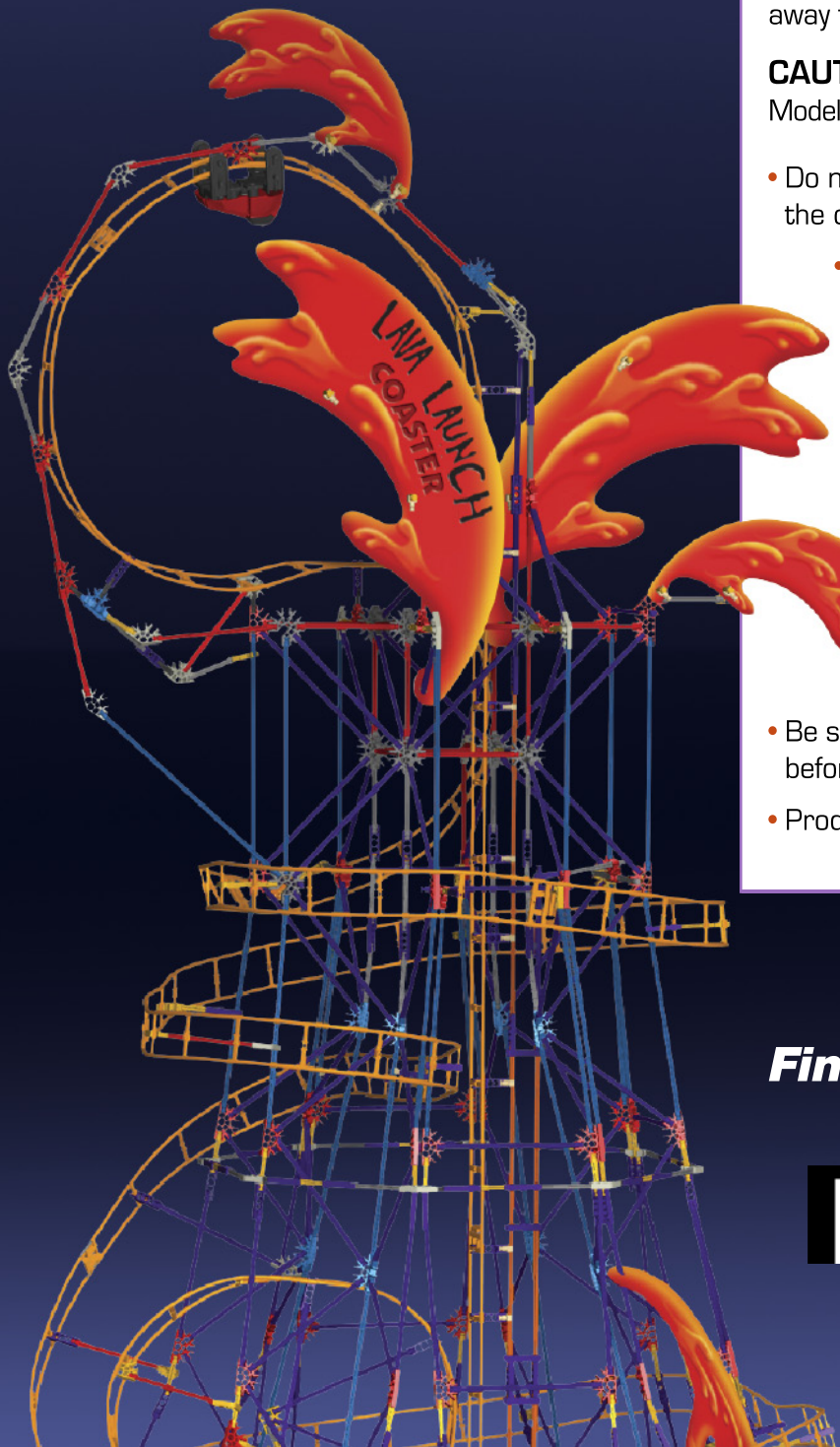

## IMPORTANT STUFF FOR PARENTS & KIDS

**Keep these instructions in a handy location. They contain important safety information.**

**Read all warnings and instructions before you start to build and operate the model.**

**⚠ WARNING: CHOKING HAZARD -**  
Small parts. Not for Children under 3 years.

**CAUTION:** Keep hands, face, hair and clothing away from all moving parts.

**CAUTION:** Be careful not to tip the model over. Model should be placed on a flat and hard surface.

- Do not attempt to launch anything other than the coaster car.
- Do not obstruct track with objects or any part of your body.
- Share the K'NEX experience with your child and make building with K'NEX a family fun adventure.
- Take your time to enjoy the building process. Don't rush!
- While you're building make sure you face your model in the same direction as the pictures show in the instructions.
- Be sure to install batteries into the motor before you start building your motorized models.
- Product and colors may vary.

**Find More Building Ideas at**

**KNEX.COM**

## BATTERY INFORMATION

### Caution: To Avoid Battery Leakage

- Be sure to insert the batteries correctly and always follow the toy and battery manufacturers' instructions.
- Do not mix old and new batteries or alkaline, standard (carbon-zinc) or rechargeable (nickel-cadmium) batteries. Only batteries of the same or equivalent type recommended should be used.
- Always remove weak or dead batteries from the product; do not short-circuit supply terminals.
- Insert batteries with correct polarity (+/-) as shown.

### Important Tips

- Alkaline batteries C (LR14) are recommended.
- Rechargeable batteries are not recommended.
- Remove rechargeable batteries from toy before charging; they must be charged only under adult supervision.
- Non-rechargeable batteries must not be recharged.
- Keep components free of dust; do not immerse or use in water.
- Do not dispose of batteries in a fire; they could leak or explode and cause injury.
- Remove all batteries if the toy will not be used for a long period of time.
- Do not put rods smaller than 2 inches in any openings of the motor; they will damage the motor, and cannot be removed.
- Help the environment by disposing of your product and packaging responsibly. The wheelee bin symbol indicates that the product and batteries must not be disposed of in the domestic waste as they contain substances which can be damaging to the environment and health. Please use designated collection points or recycling facilities when disposing of the item or batteries.

### How to Insert and Remove Batteries

- Use a small Phillips head screwdriver to loosen the screw. Insert 3 fresh C batteries (LR14) into the compartments with the correct polarity (+/-) as shown here.

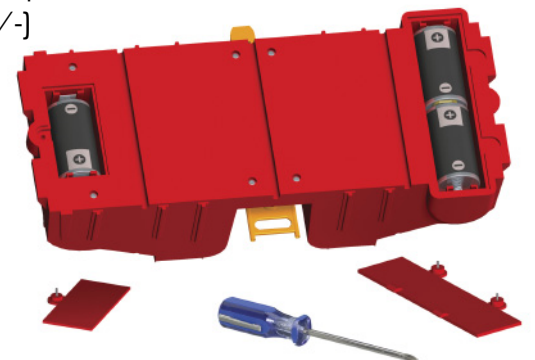

# K'NEX BUILDING BASICS

## Start Building

To begin your model, find the **1** and follow the numbers. Each piece has its own shape and color. Just look at the pictures, find the pieces in your set that match and then connect them together. Try to face your model in the same direction as the instructions while you build. Faded colors show you this section is already built. You'll want to connect the new section to the place where the arrows are pointing.

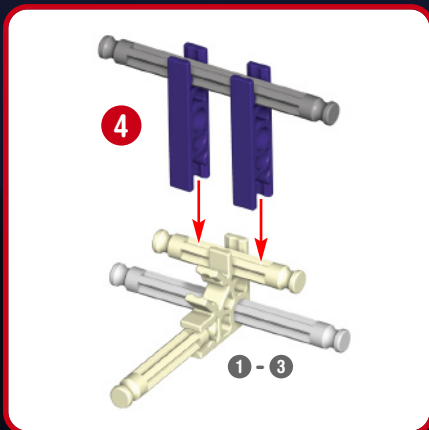
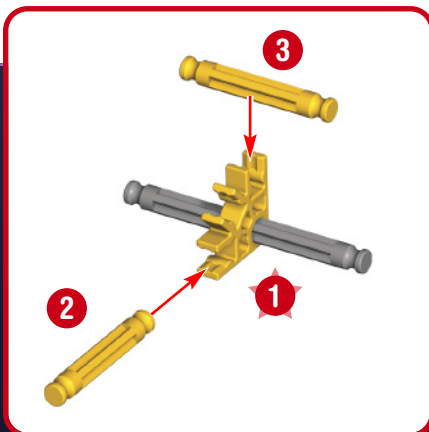

## Parts Count

Before you start building, be sure to compare the parts in your set with the parts listed here. If anything is missing, call or write to us using the information on the back cover. We're here to help!

## Motor

Car will go in the direction of the arrows on top of the motor. Always wait a few seconds after turning the motor on before gently pushing the car towards the motor.

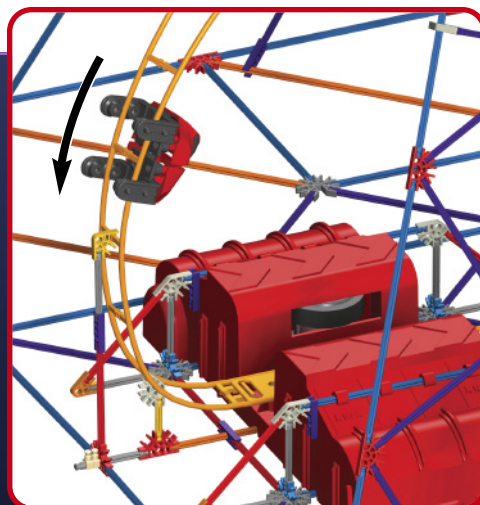

## Track

Always connect the track top side to top side throughout the build. Attach the connectors to the bottom side of the track exactly as shown. Be sure to push the connectors on firmly until they "click".

### Top Side of Track

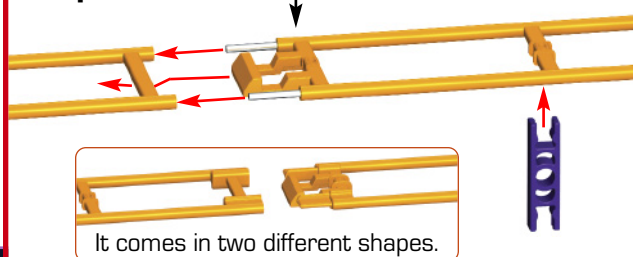

## Connectors

There are blue and gray connectors with special long slots. They slide together as you see in the pictures. Push these parts together until you hear a "click."

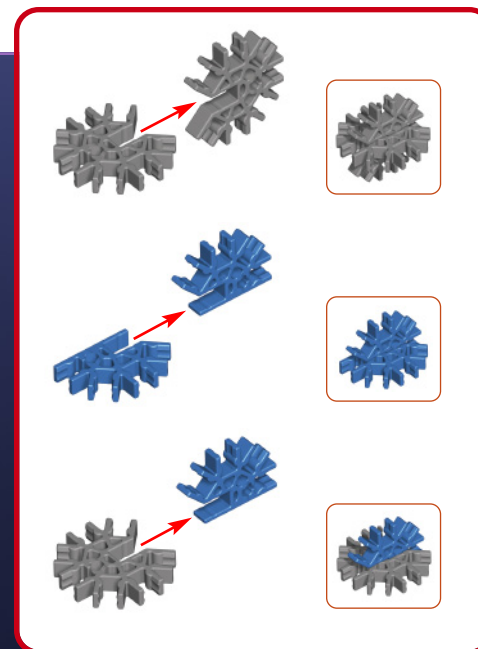

## Graphic Panels

See page 64 for attaching panels to model.

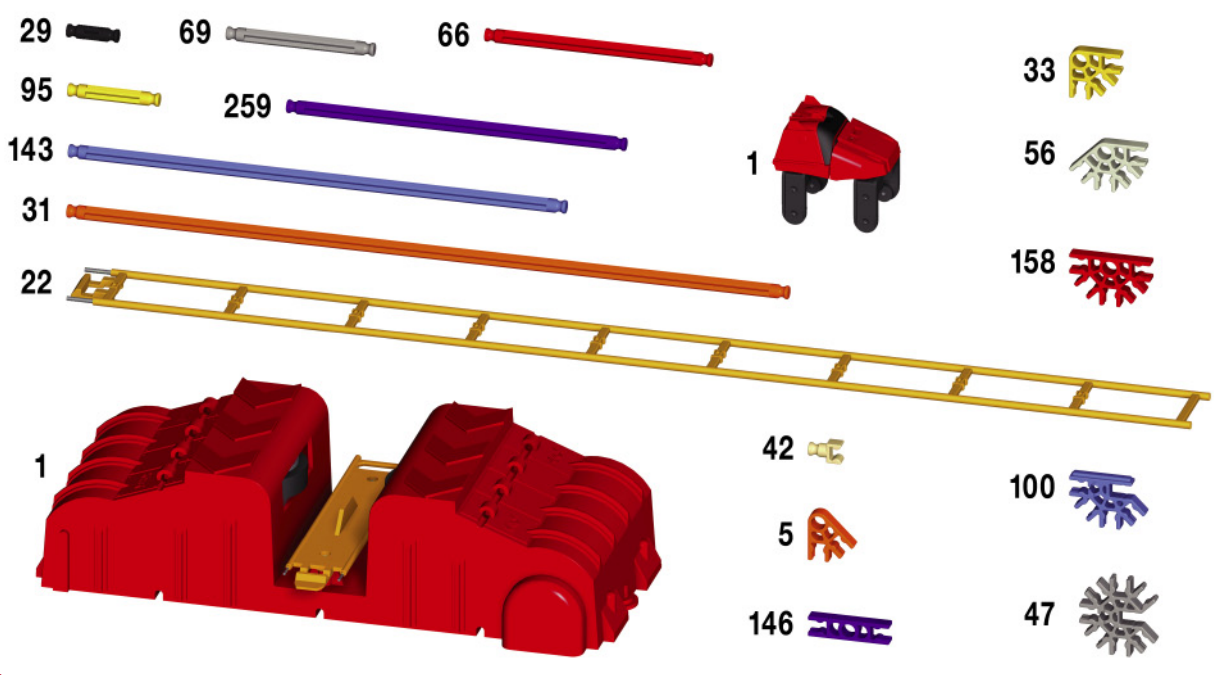
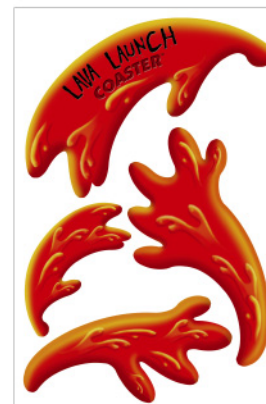

# LAVA LAUNCH COASTER™

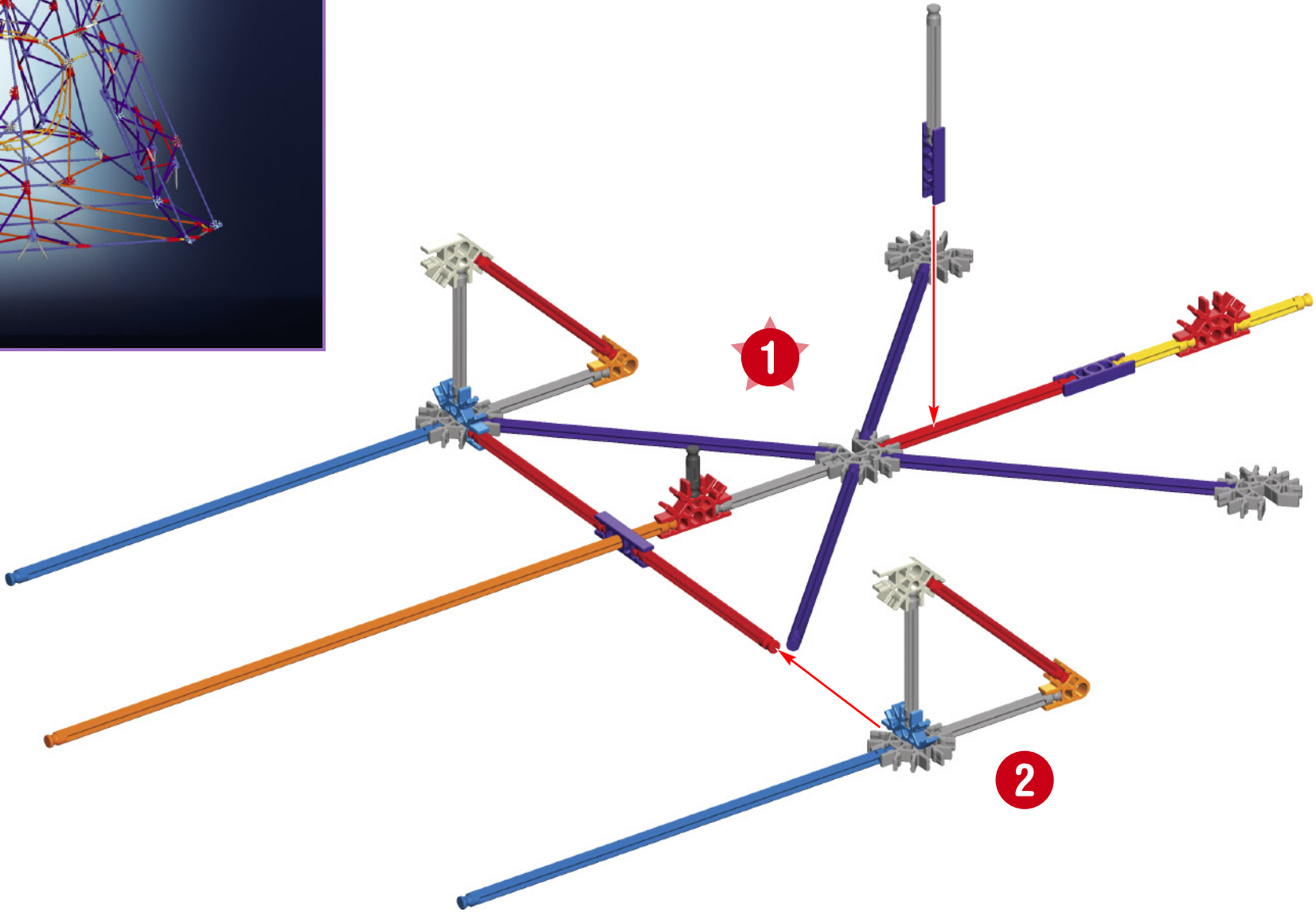
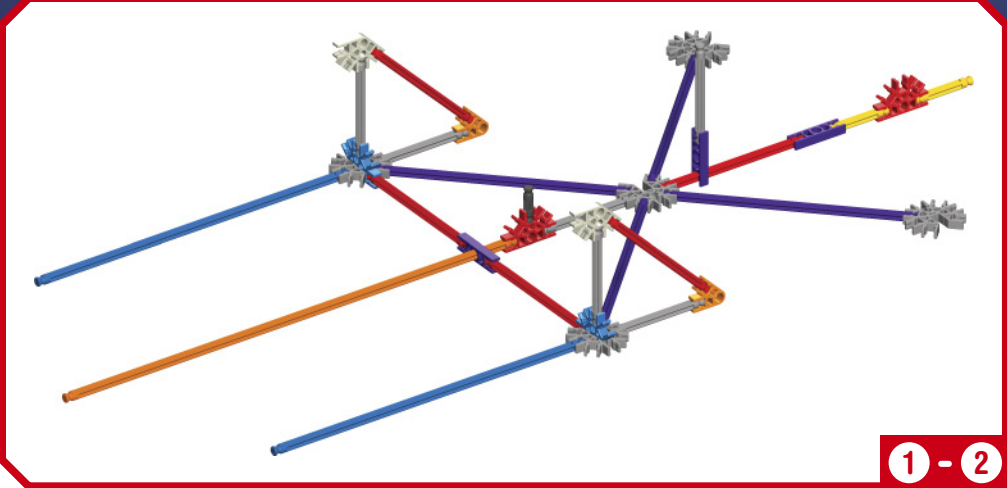
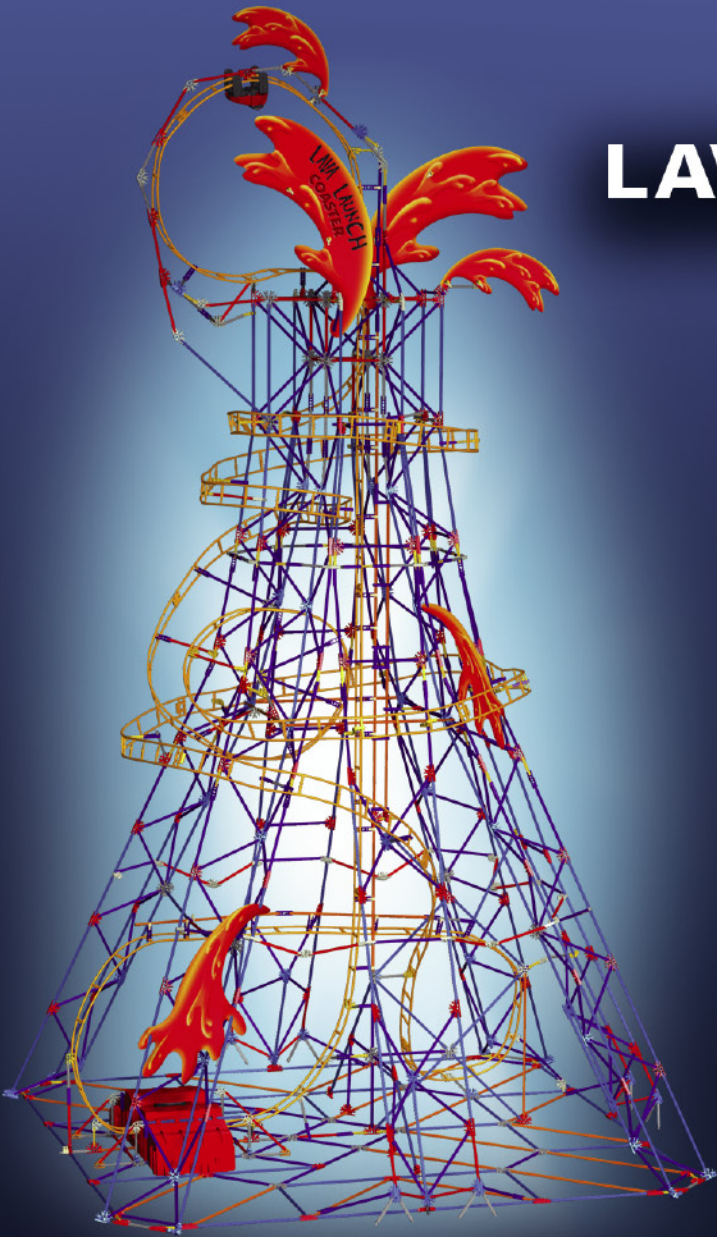

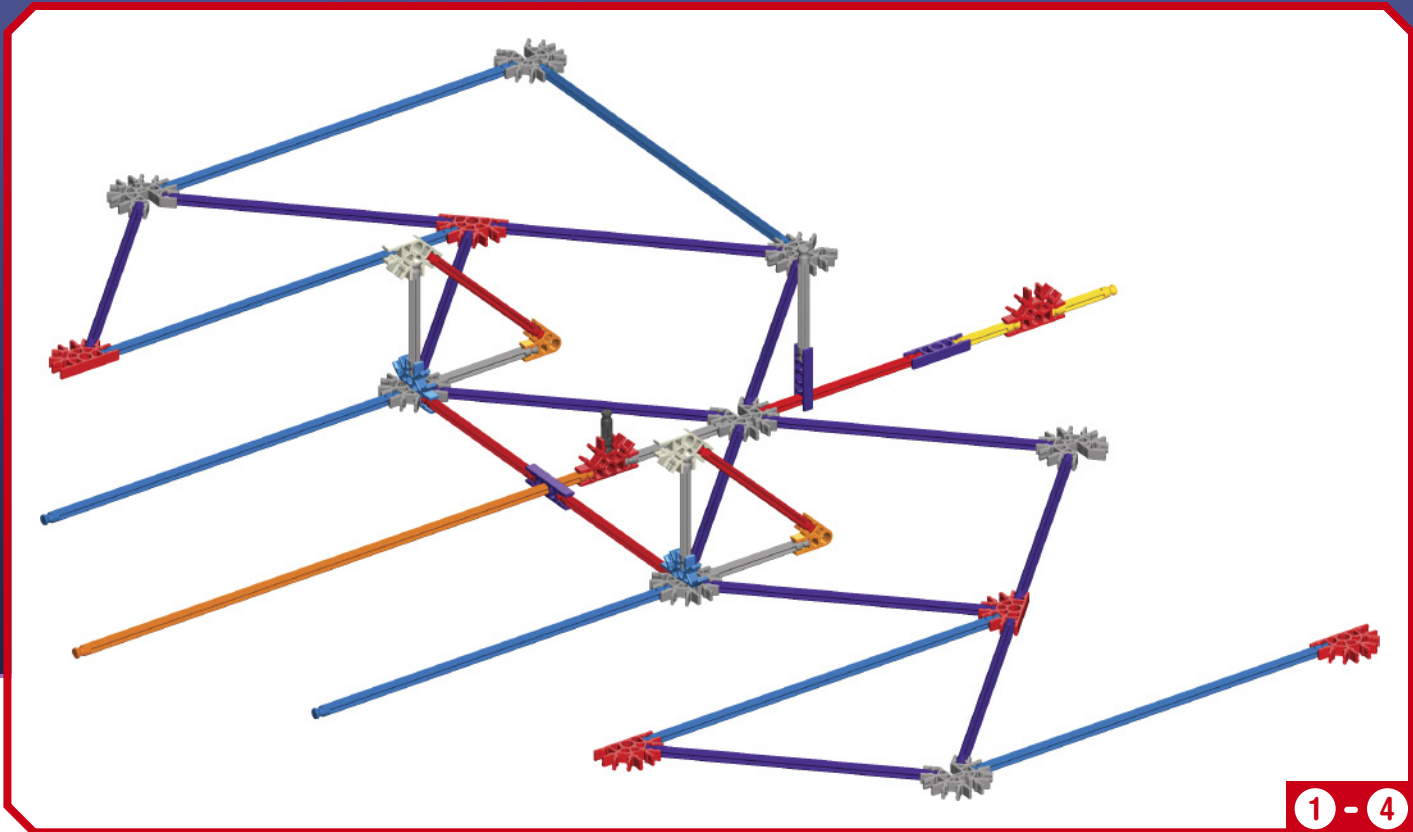

1 - 4

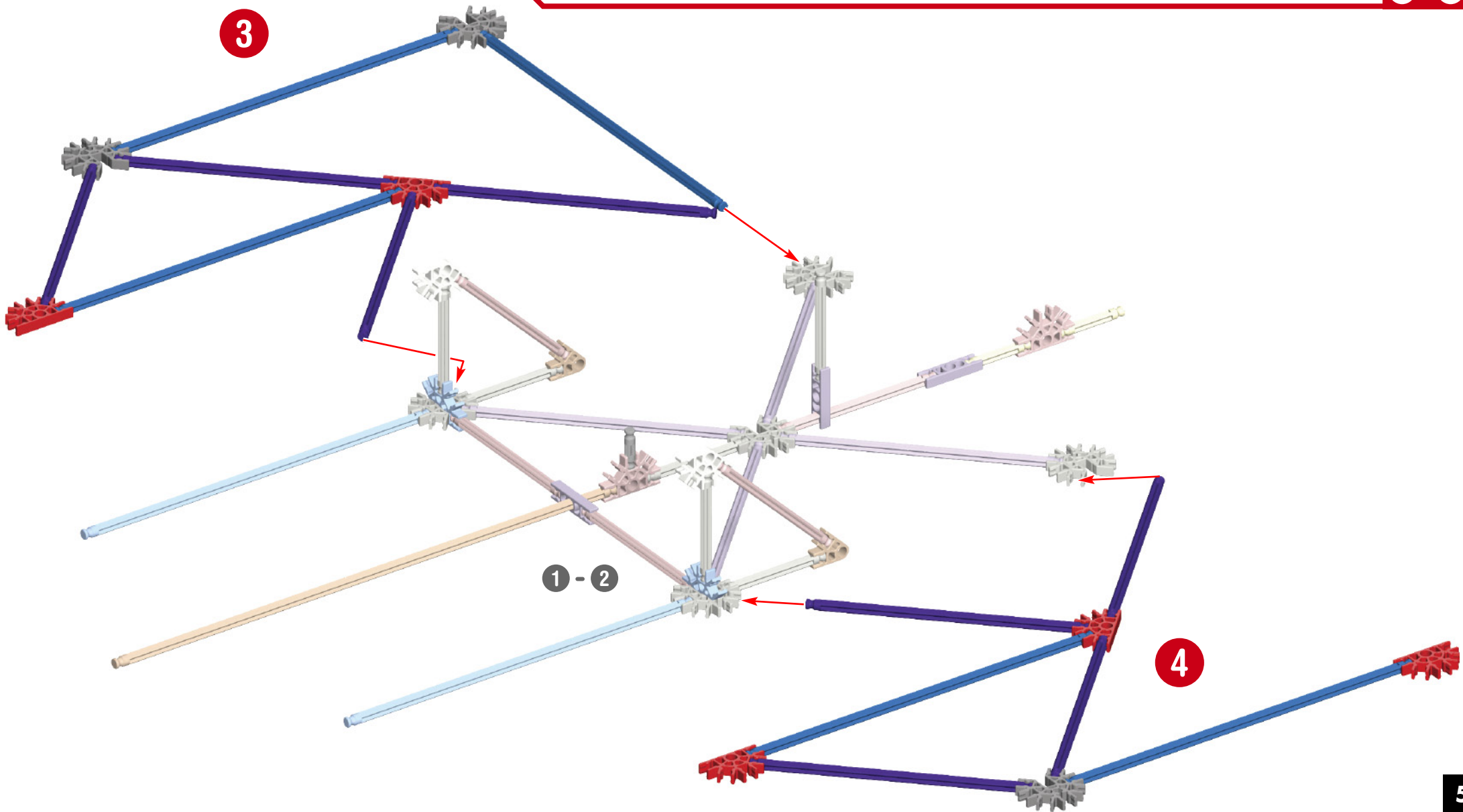

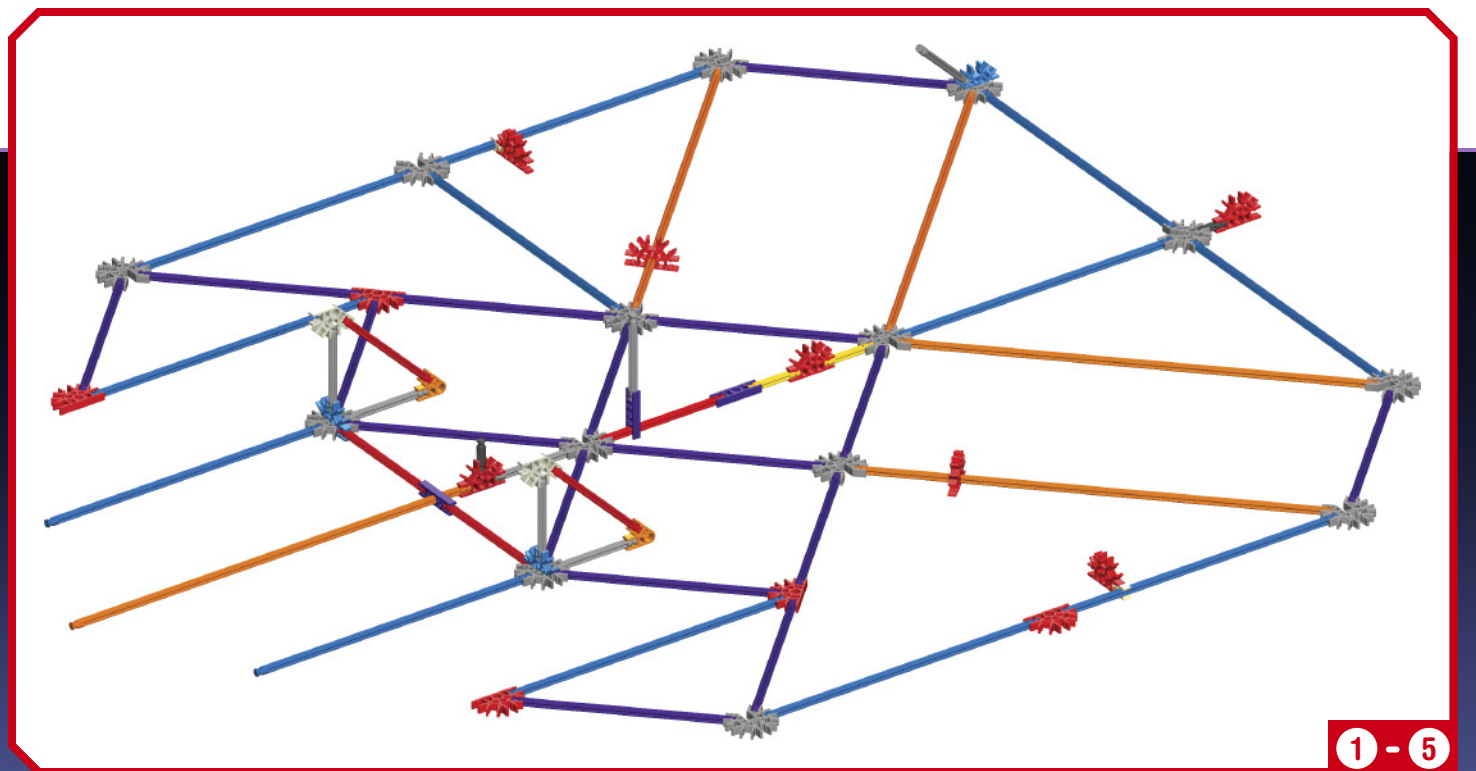
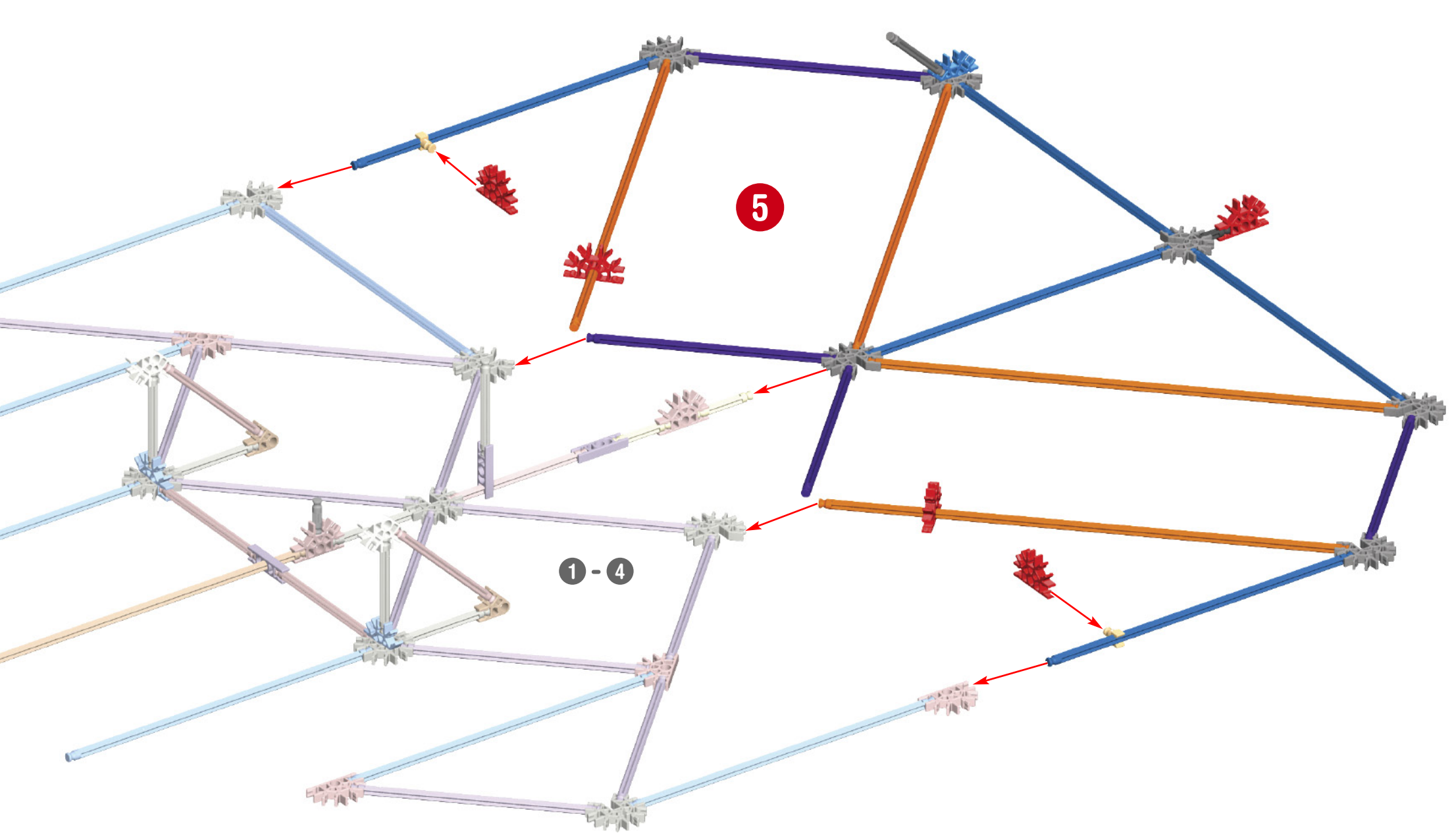

Did you install 3 C (or LR14) batteries in the motor?

- (FR)** Est-ce que tu as installé 3 C (ou LR14) dans le moteur ?
- (ES)** ¿Instalaste 3 pilas C (o LR14) en el motor?
- (DE)** Heb je 3 C (of LR14) batterijen gestoken in de motor?
- (IT)** Hai installato 3 batterie C (o LR14) nel motore?
- (PT)** Foram instaladas as pilhas 3 C (ou LR14) no motor?
- (NL)** Heb je er 3 C (of LR14) batterijen ingestoken?

6

1 - 5

7

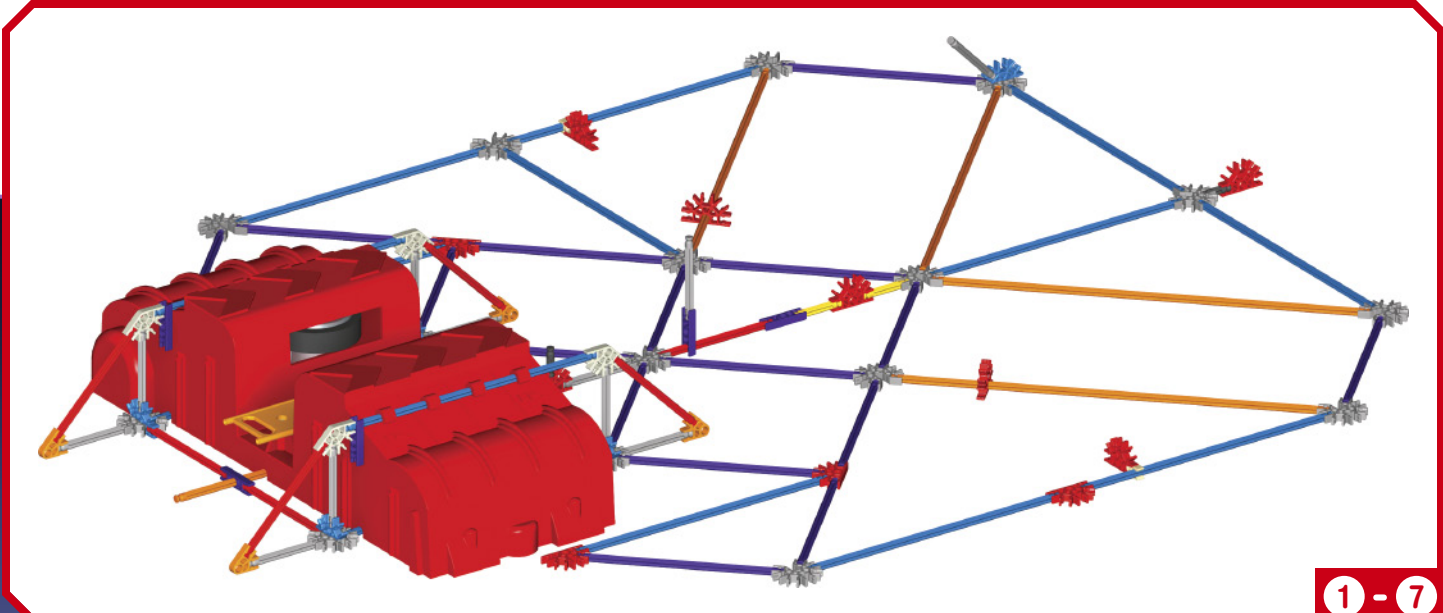

1 - 7

8

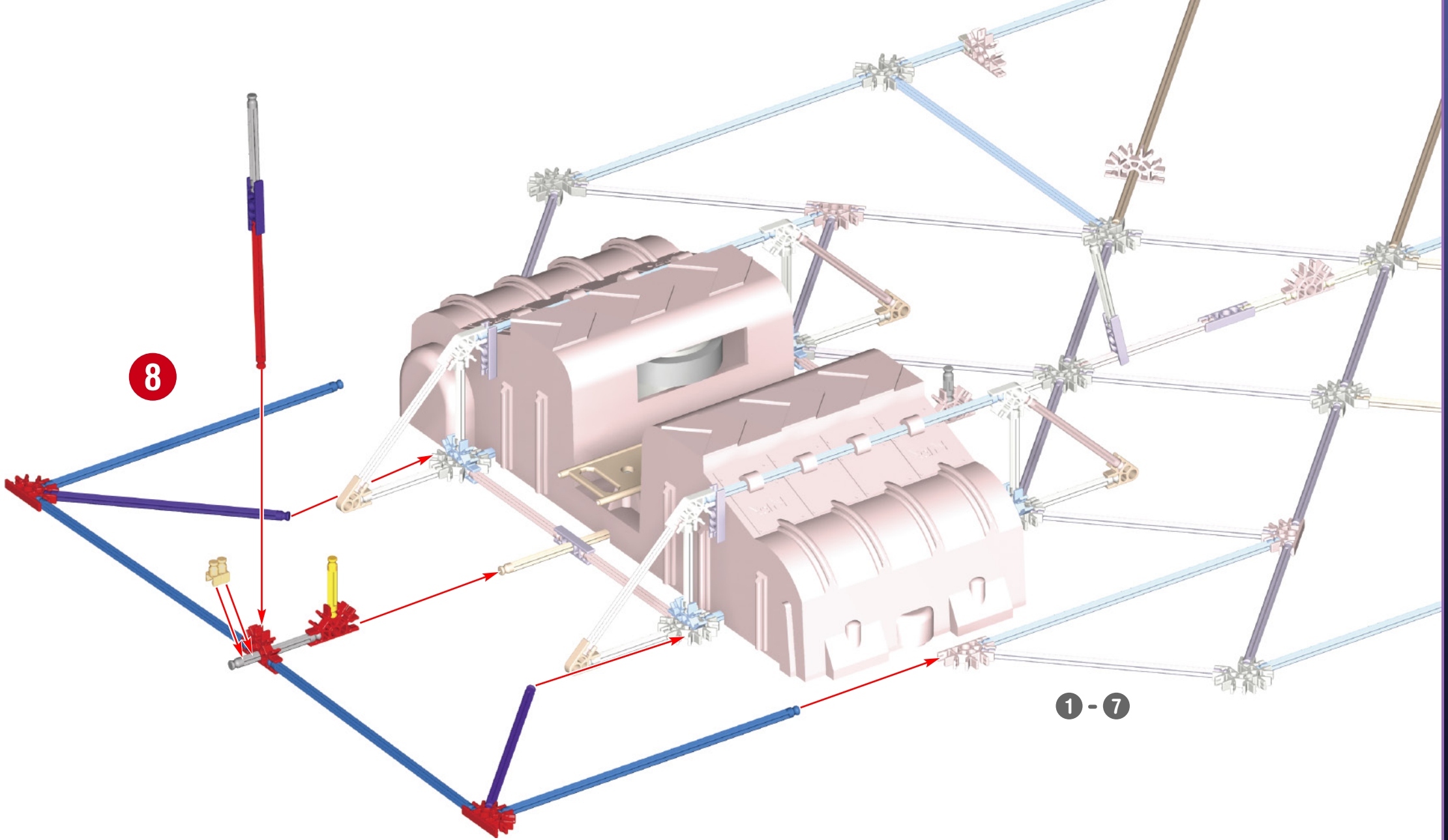

1 - 7

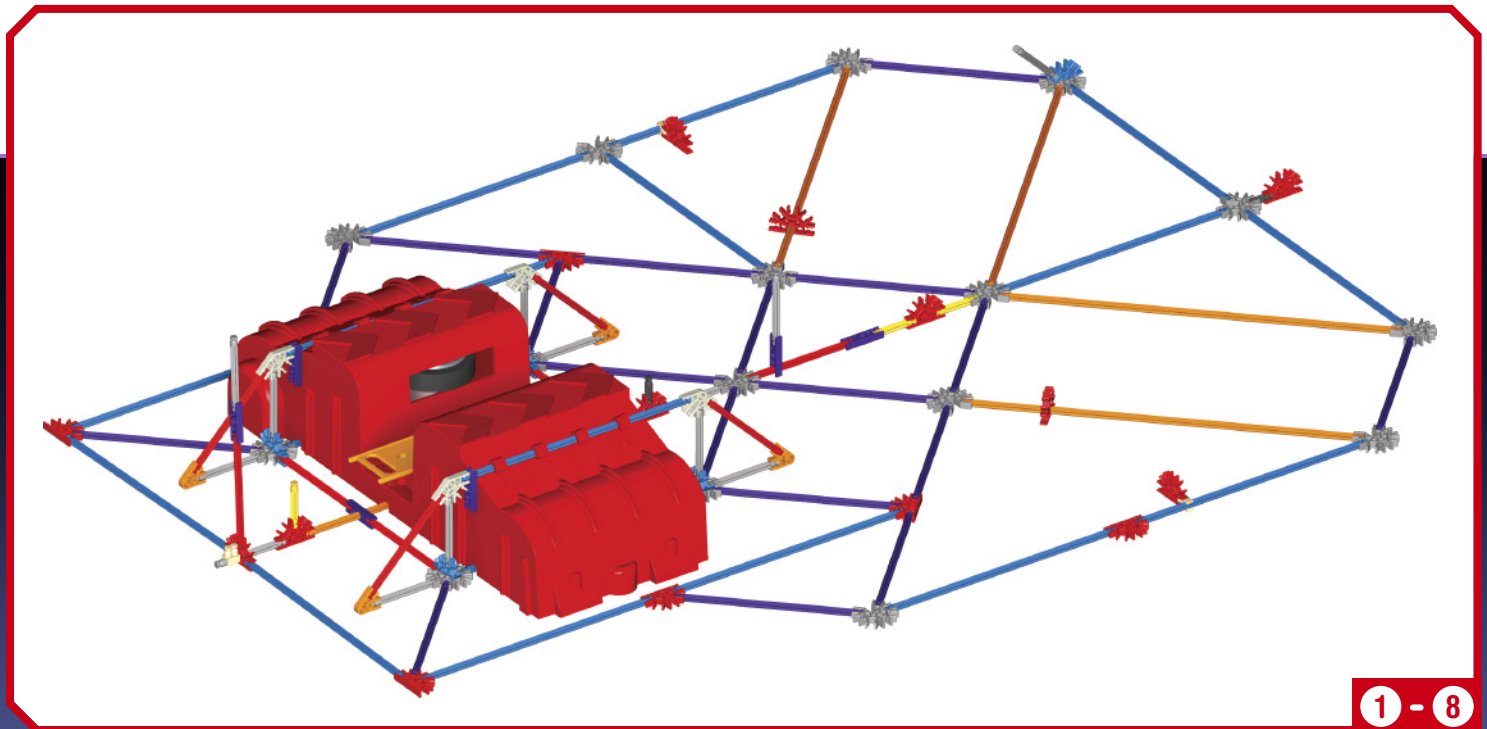

1 - 8

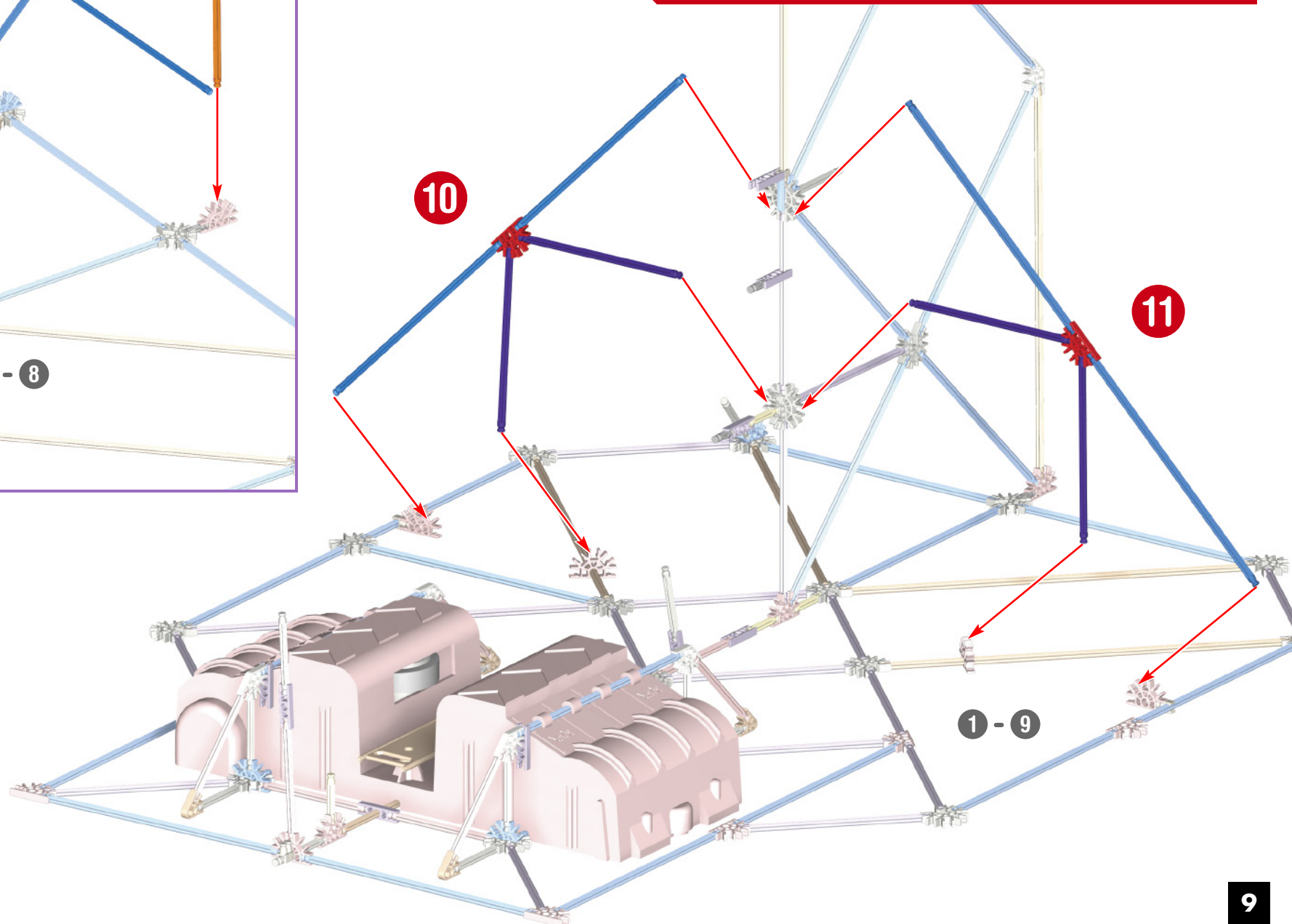
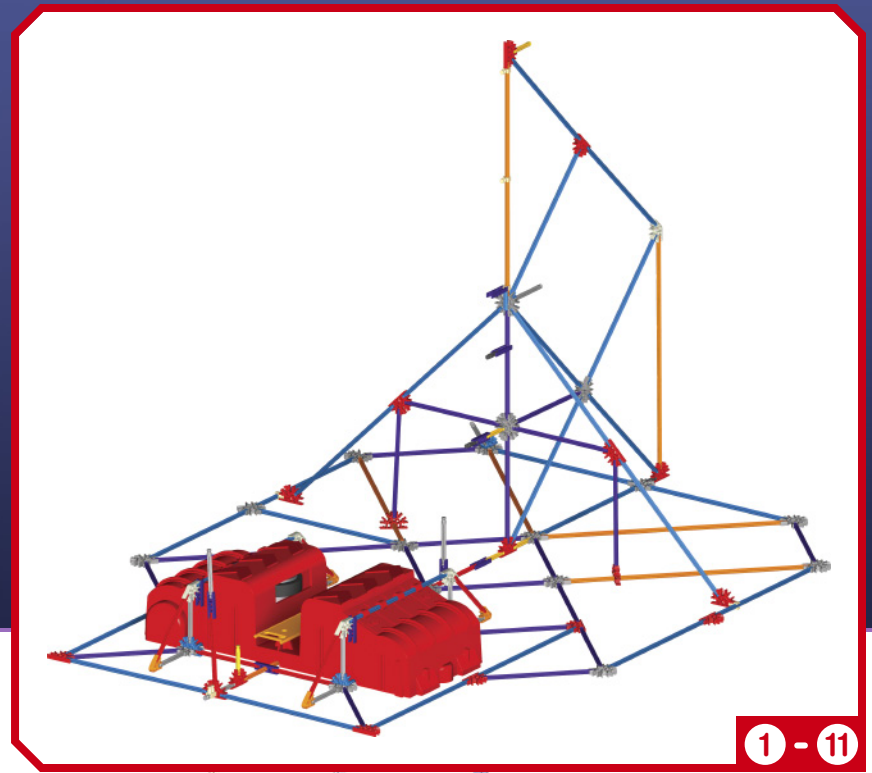
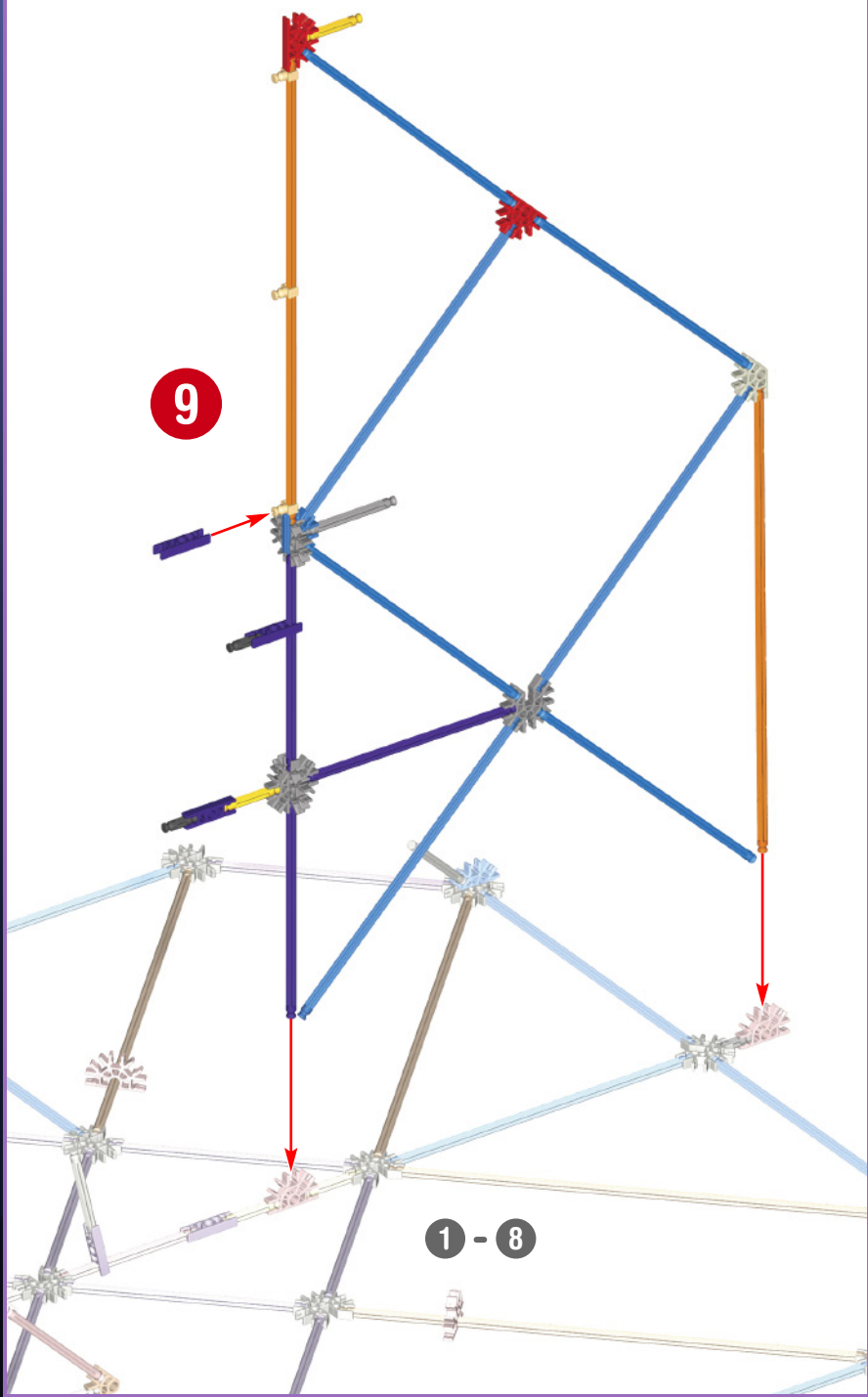

12

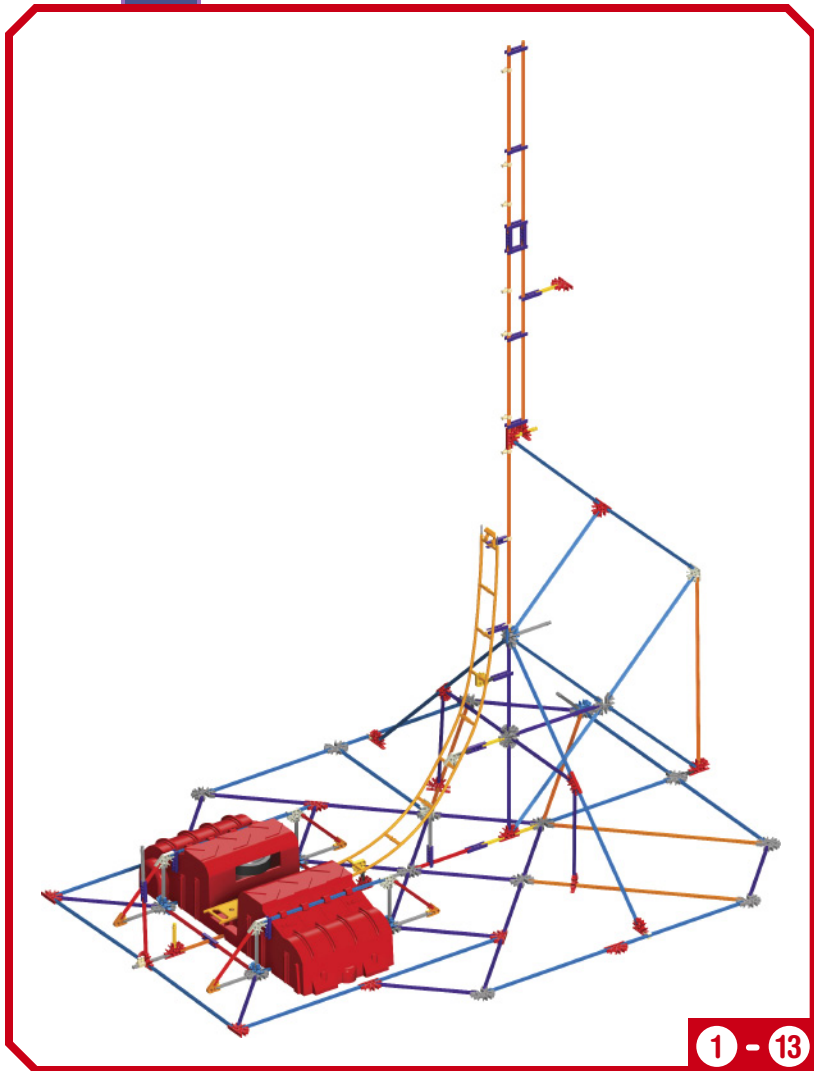
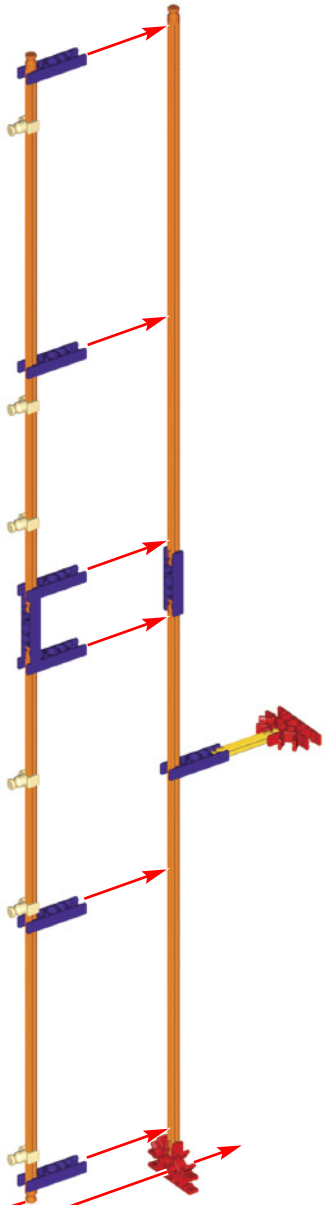

1 - 13

13



1 - 12

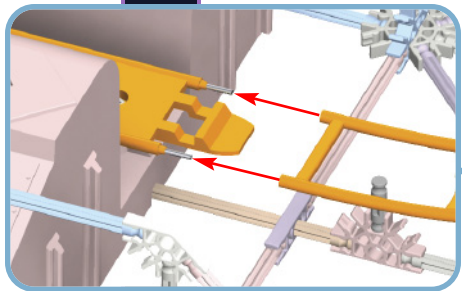

1 - 11

10

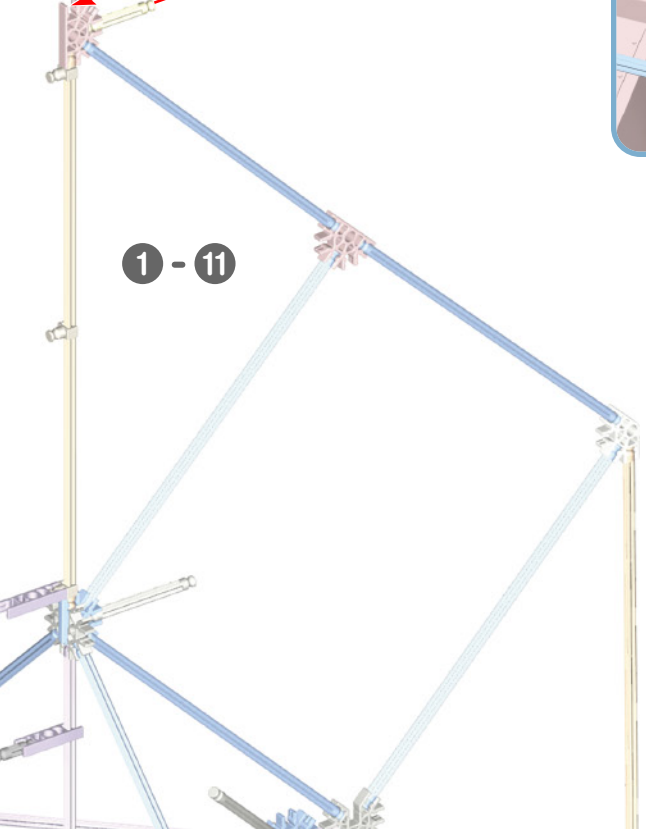

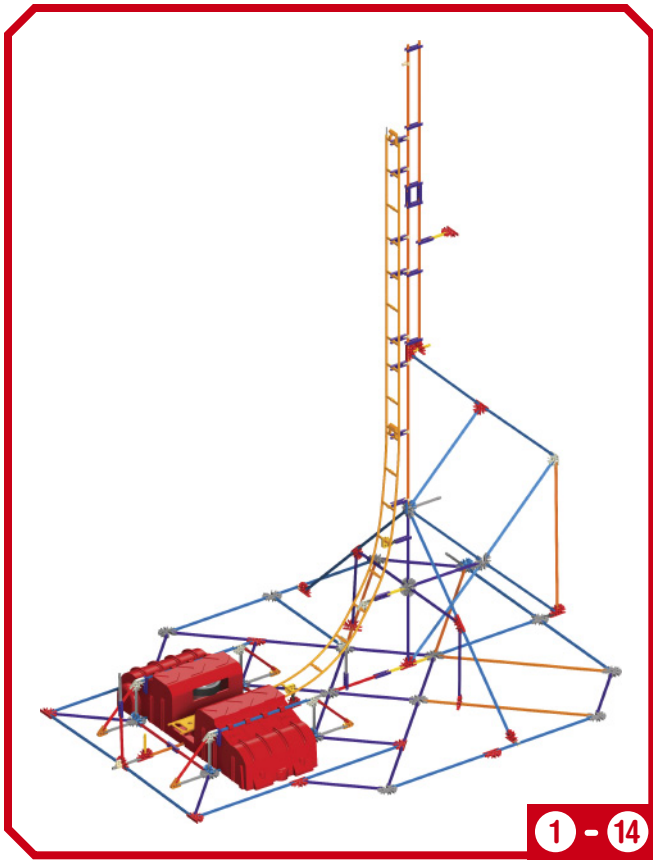

1 - 14

Always join this end of the track to the previous track piece first, then connect the rest of the track to the tower.

- (FR) Connecte toujours le côté supérieur du circuit contre le côté supérieur tout au long de la construction.
- (ES) Al construir, conecta siempre la pista de lado superior a lado superior.
- (DE) Die einzelnen Schienenstücke müssen immer mit der Oberseite nach oben zeigen, wenn sie miteinander verbunden werden.
- (IT) Collega sempre la rotaia parte superiore a parte superiore in tutta la costruzione.
- (PT) Liga sempre a face superior da pista à face superior durante a montagem.
- (NL) Maak steeds de bovenkant van het spoor vast aan de bovenkant tijdens de opbouw.



It comes in two different shapes.

- (FR) Il est fait dans deux différents styles.
- (ES) Esto viene a dos estilos diferentes.
- (DE) Es kommt in zwei verschiedenen Stilen.
- (IT) Si è fatto in due forme diverse.
- (PT) É feito em duas formas diferentes.
- (NL) Het is gemaakt in twee verschillende vormen.

14

1 - 13

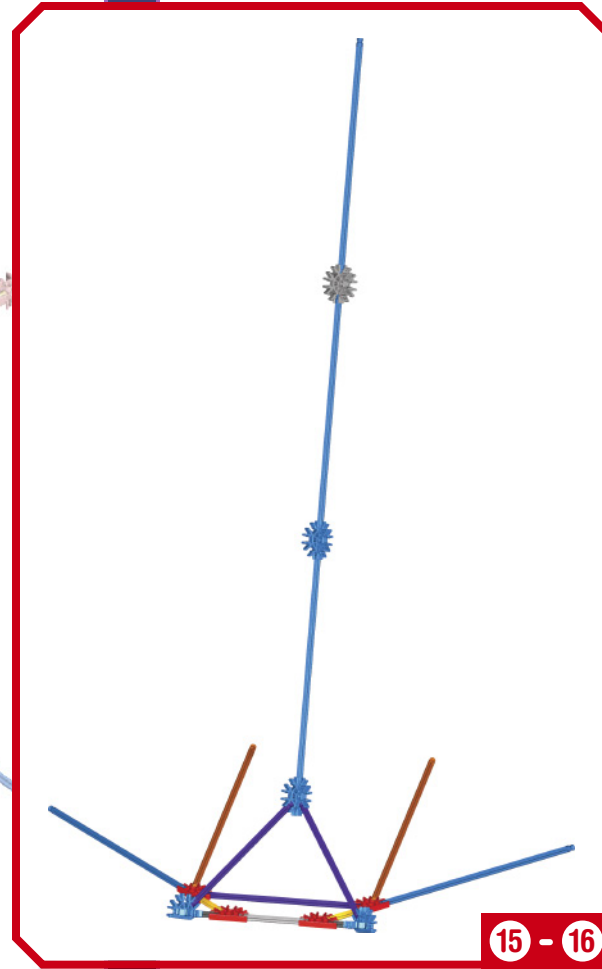

15 - 16

16

15

17

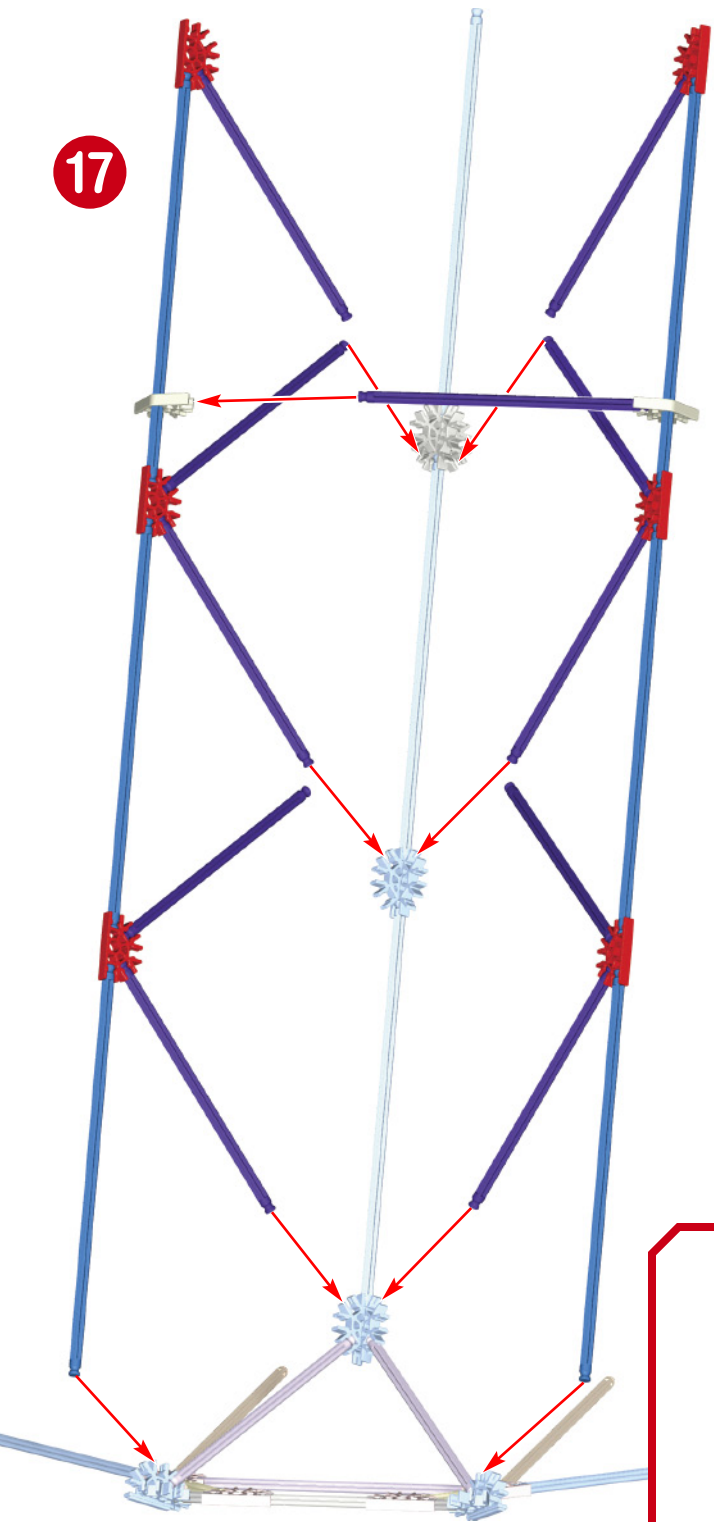

18

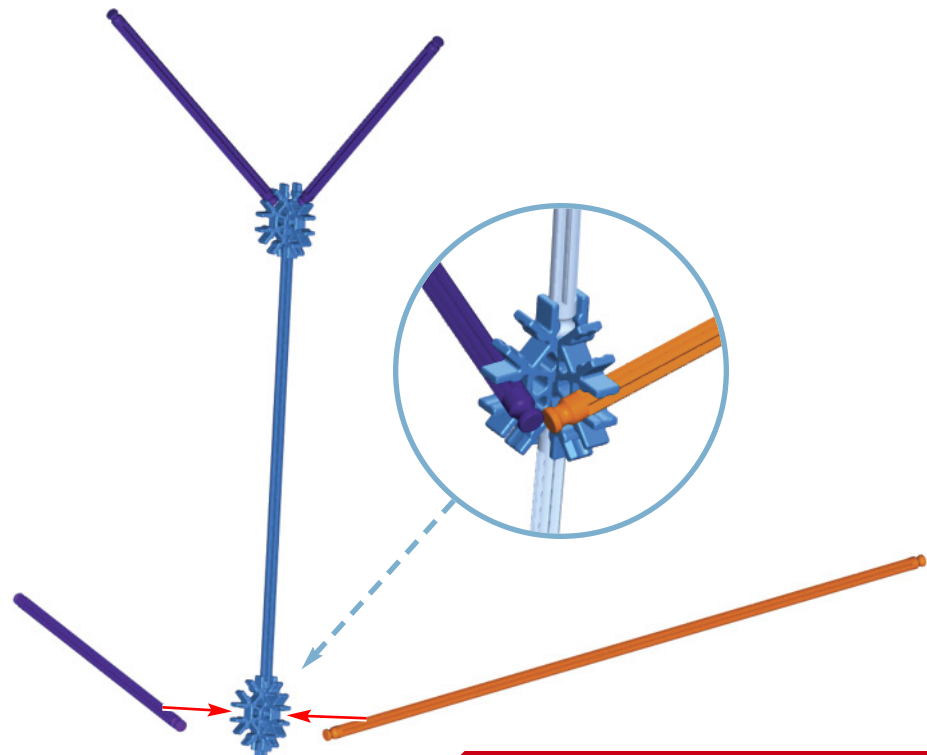

19

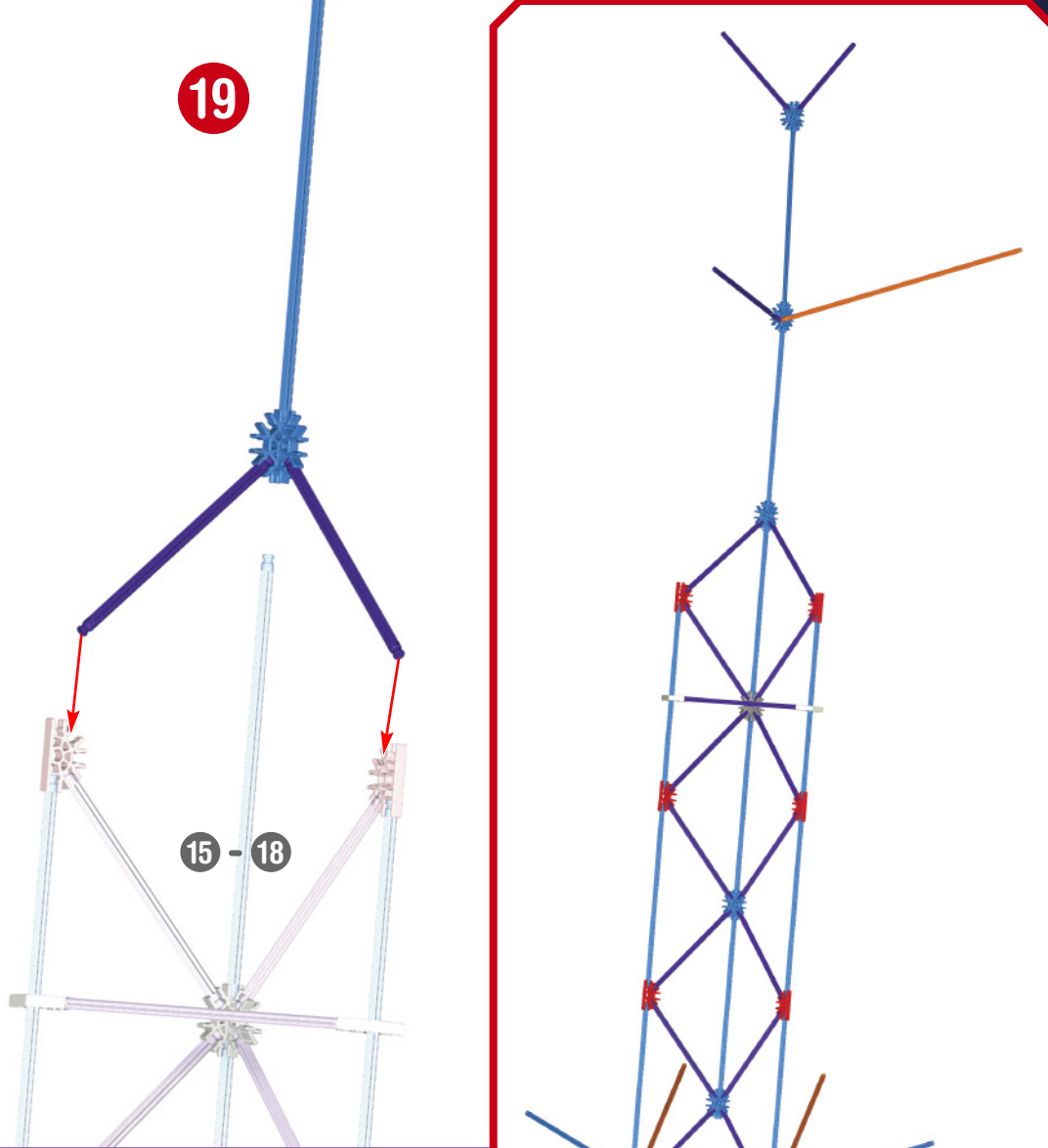

15 - 16

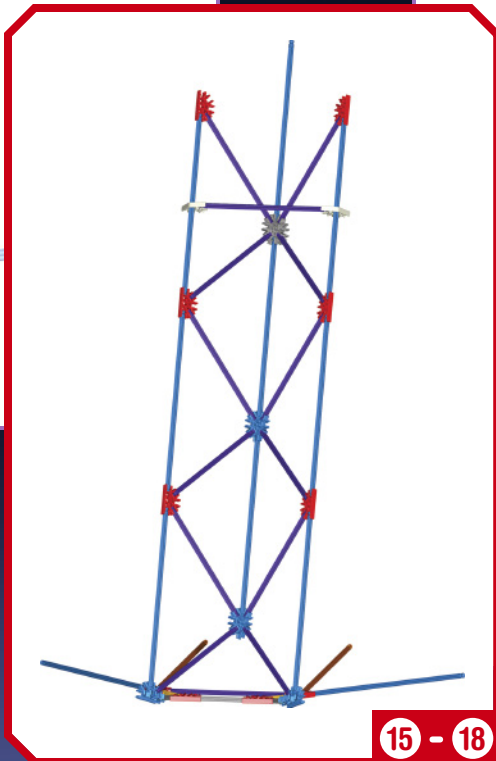

15 - 18

15 - 18

15 - 19

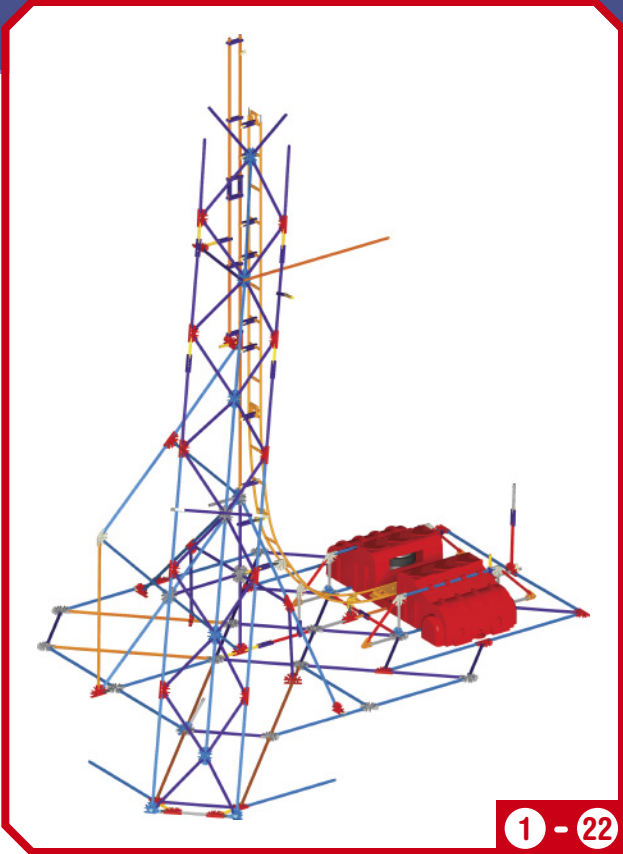
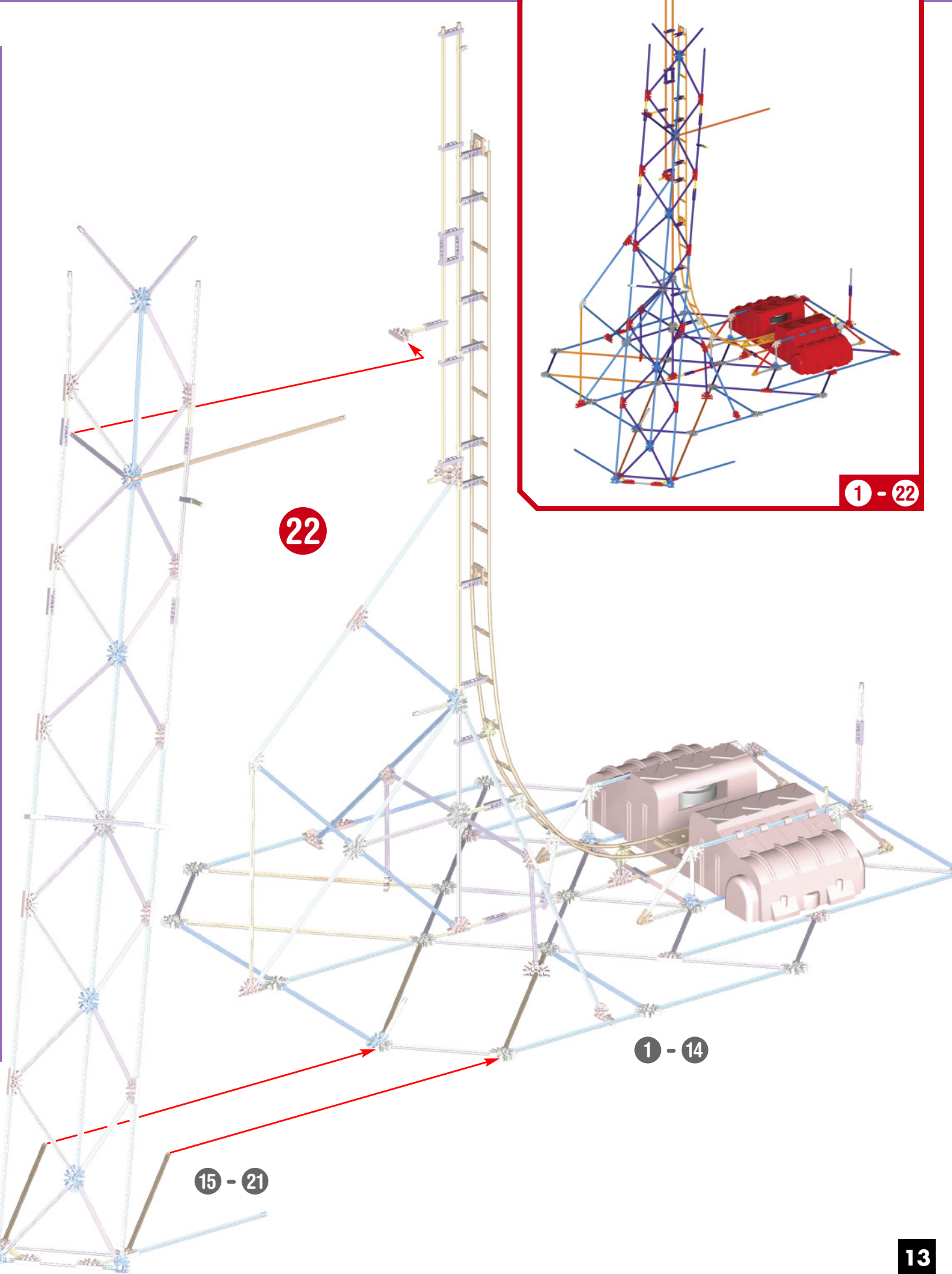
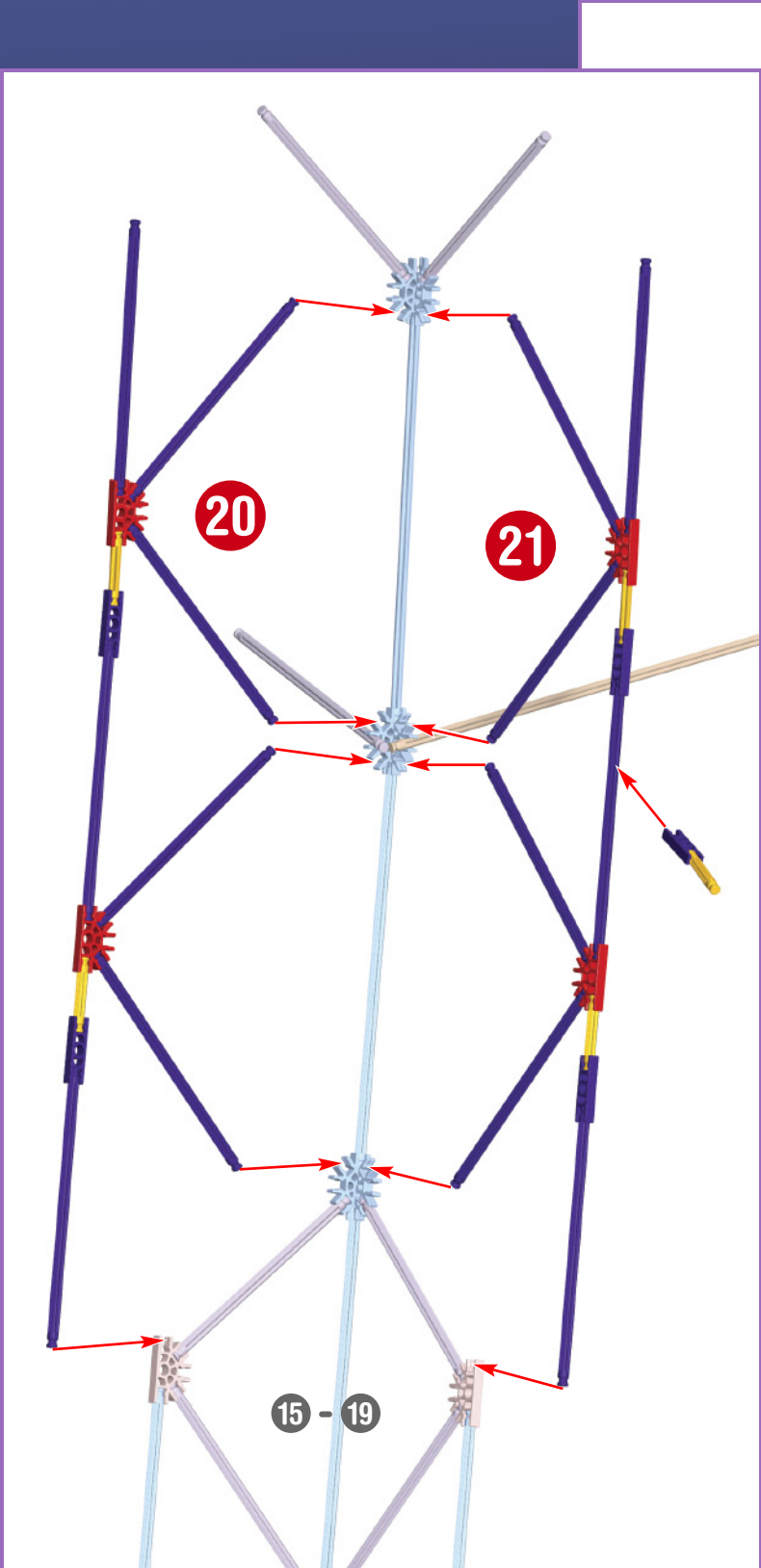

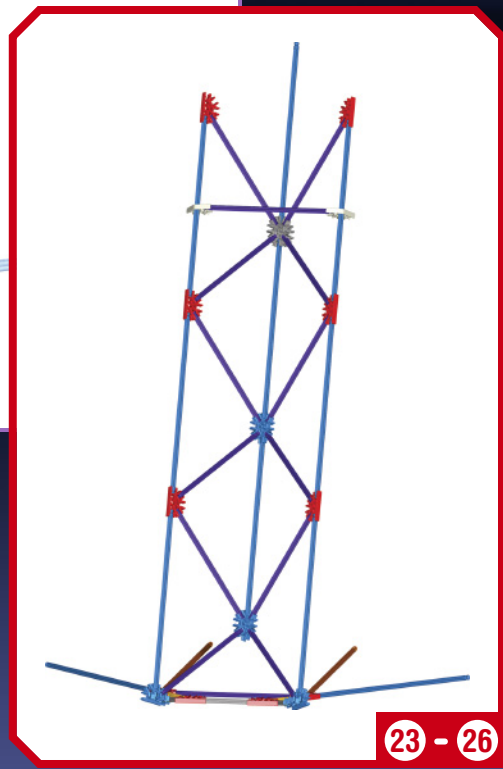
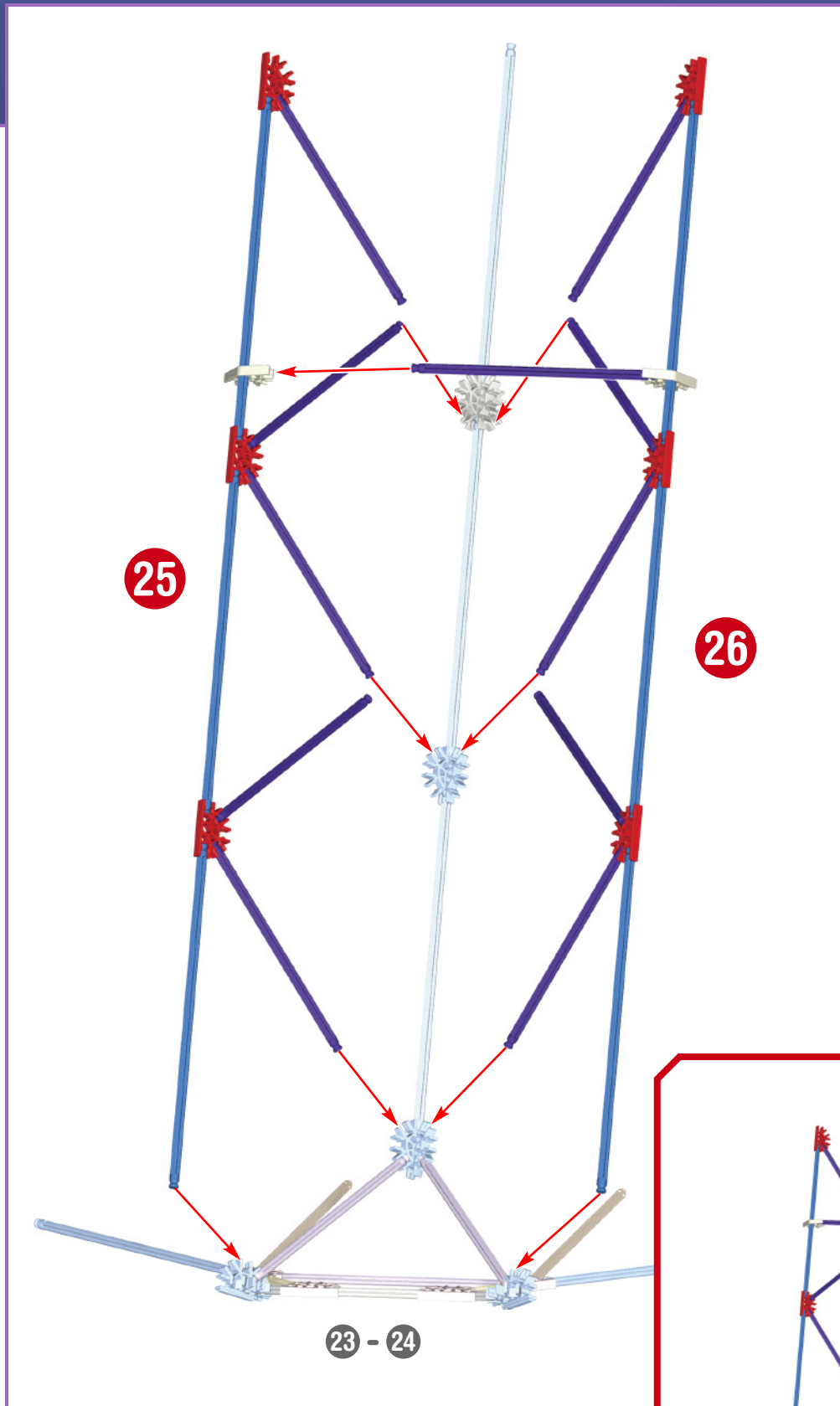
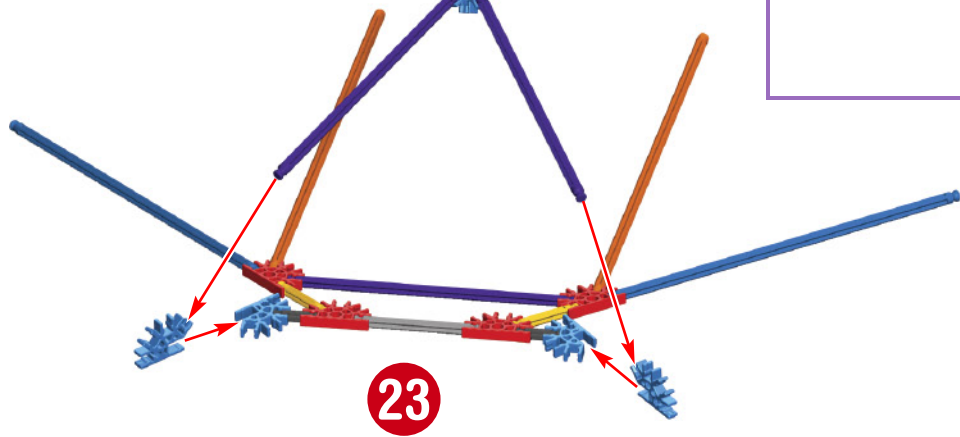
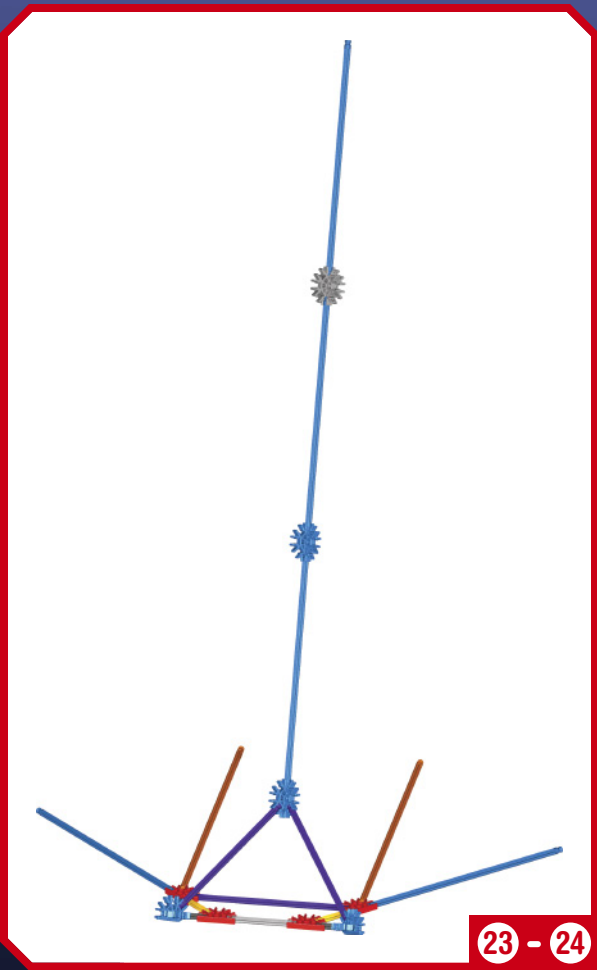

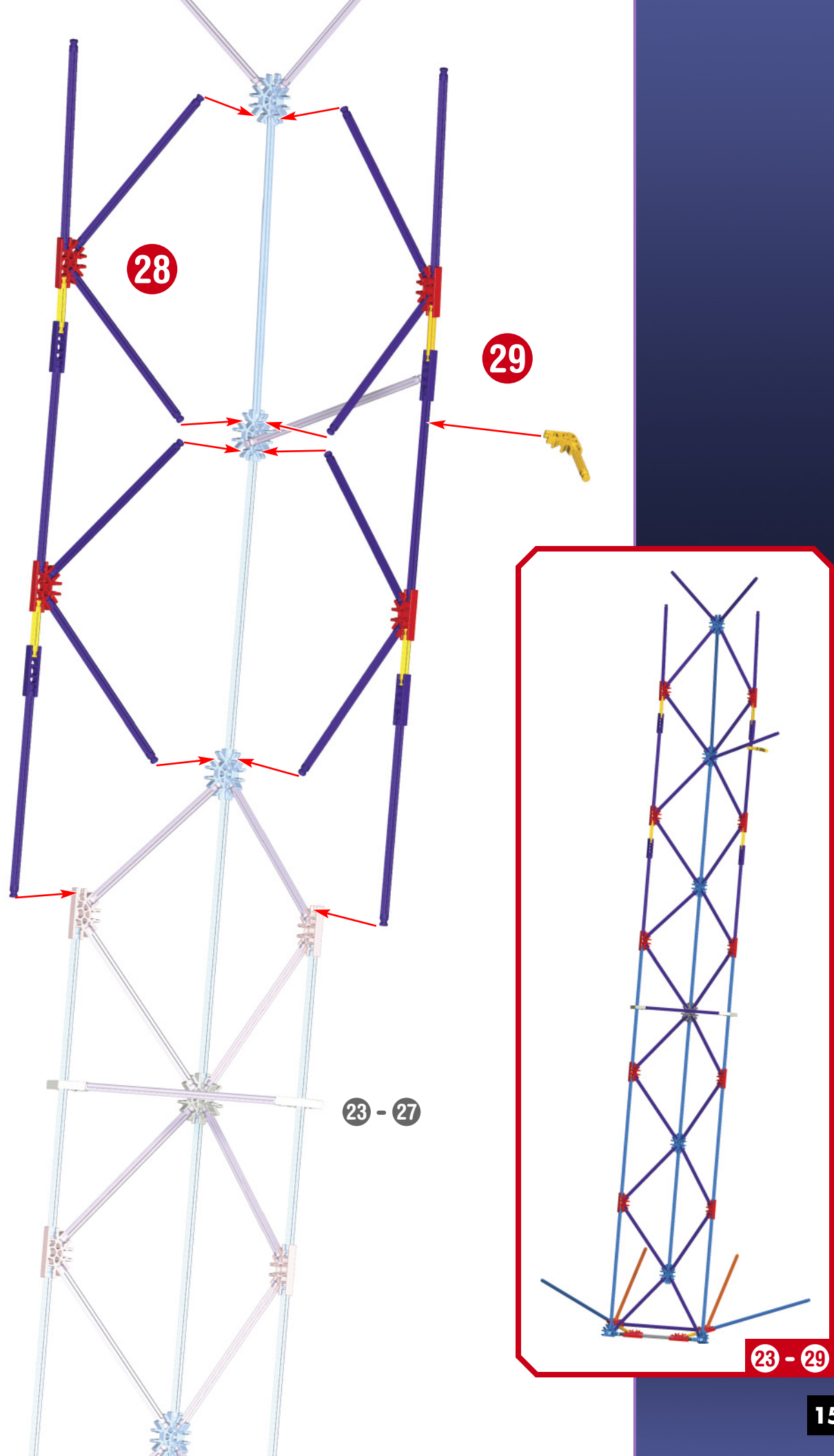
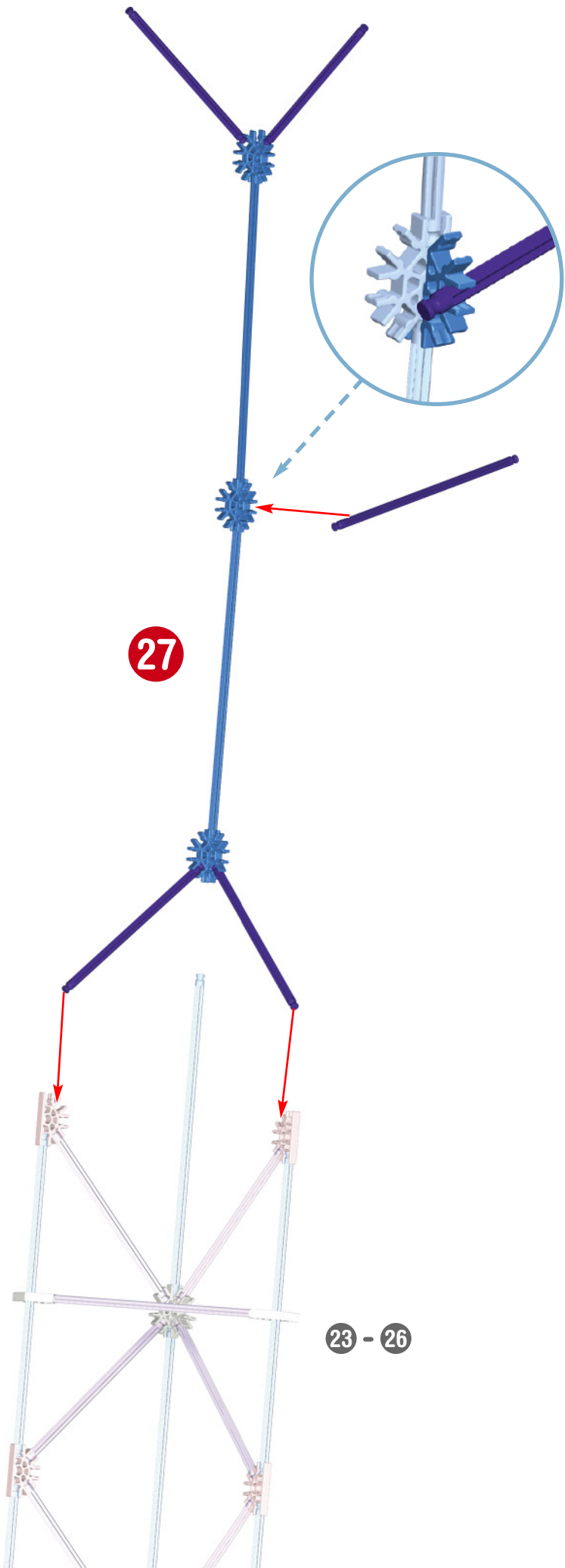

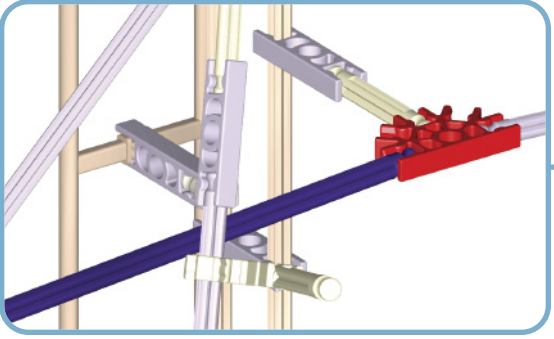
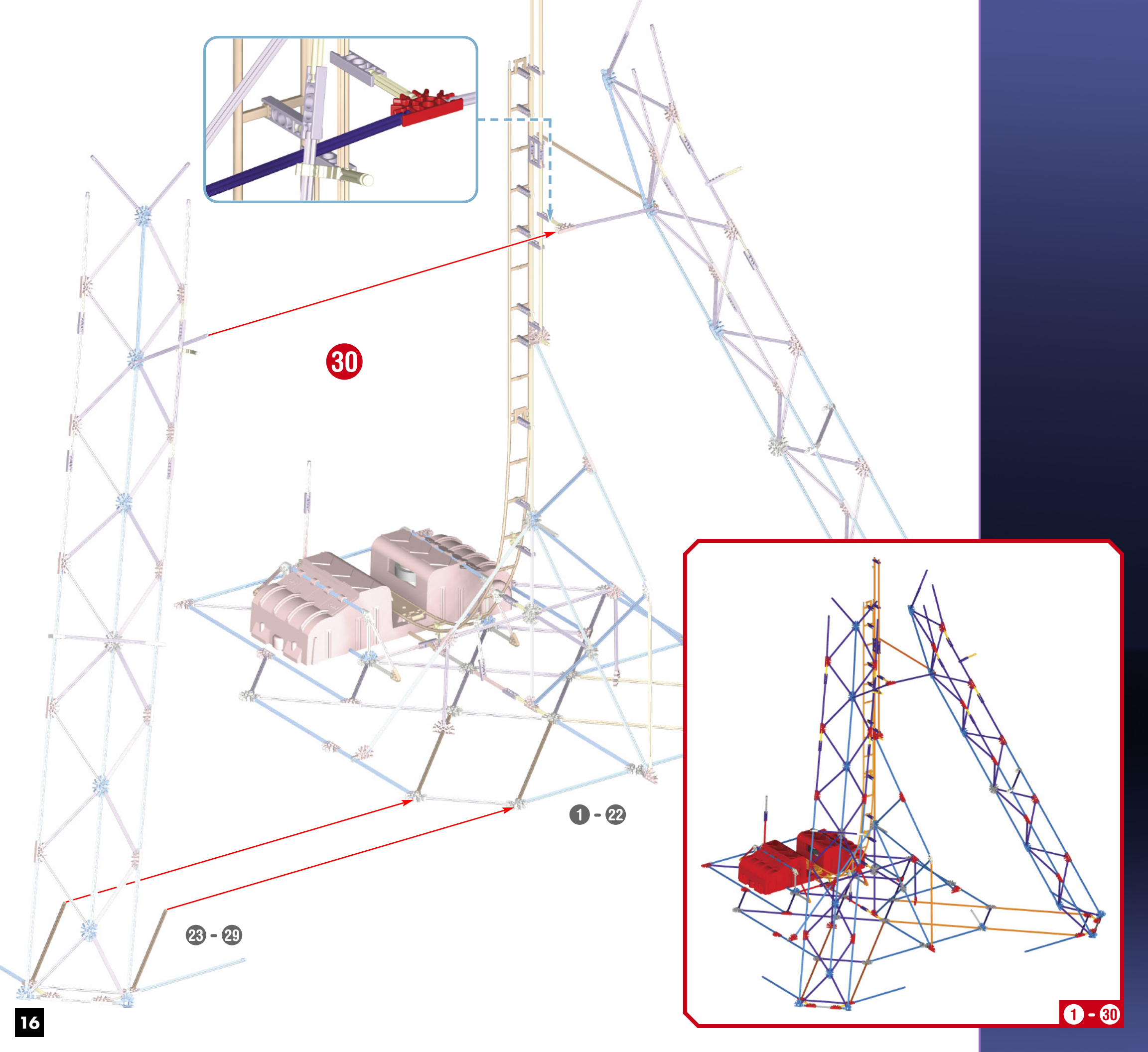

30

23 - 29

1 - 22

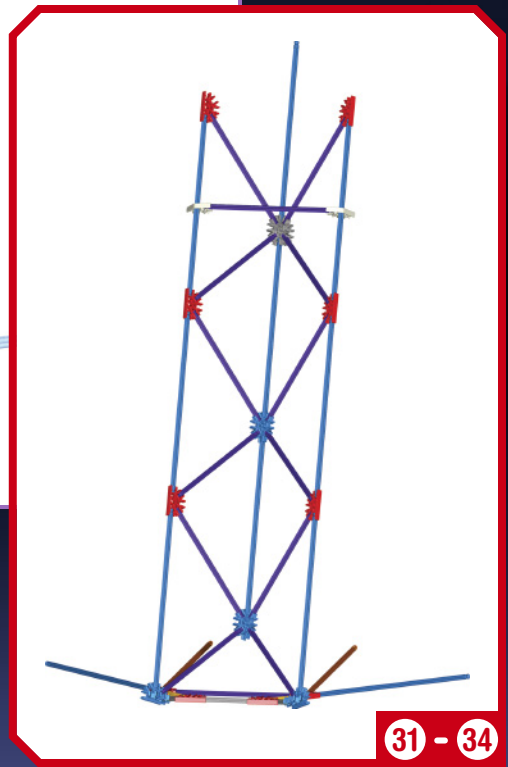
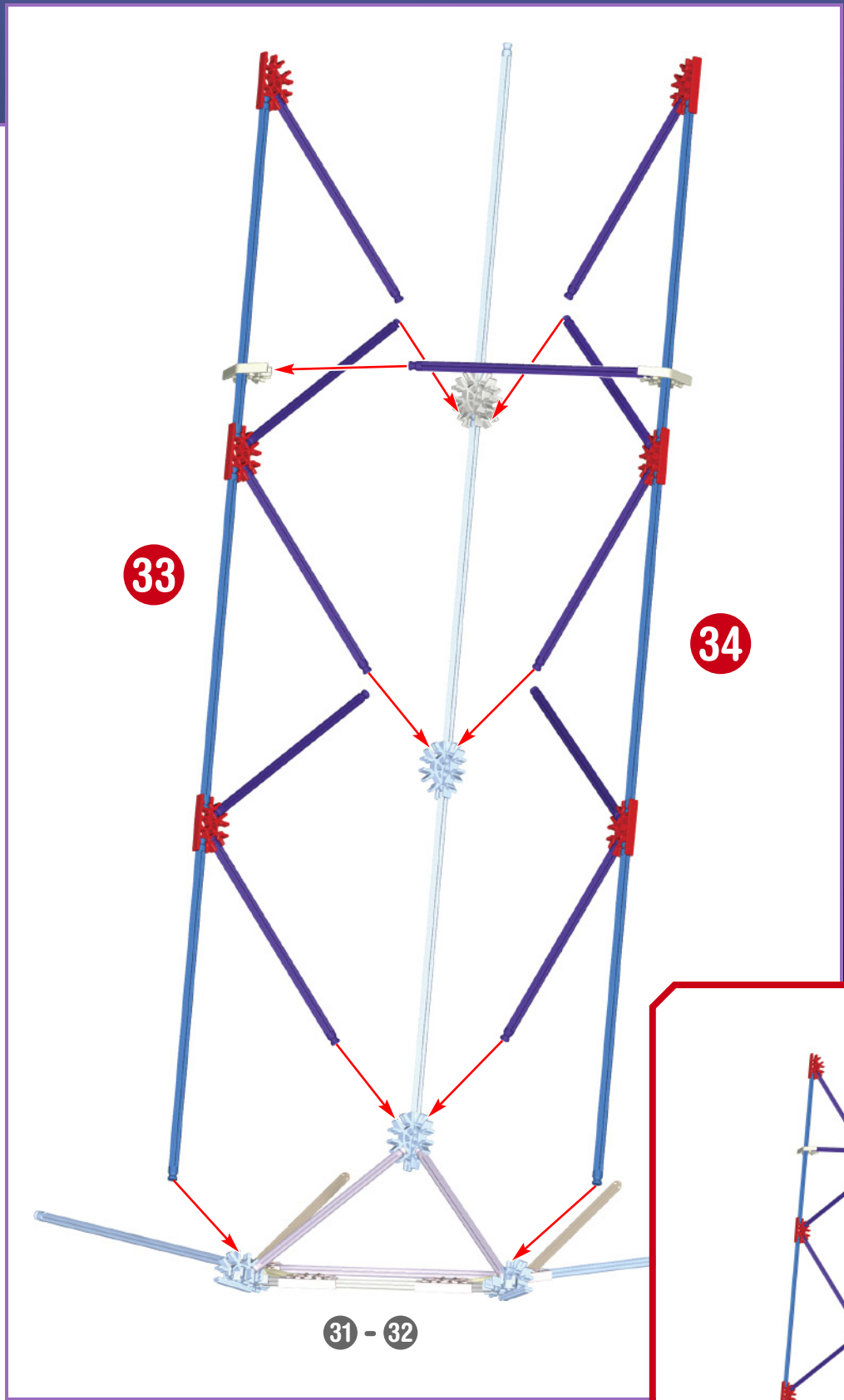
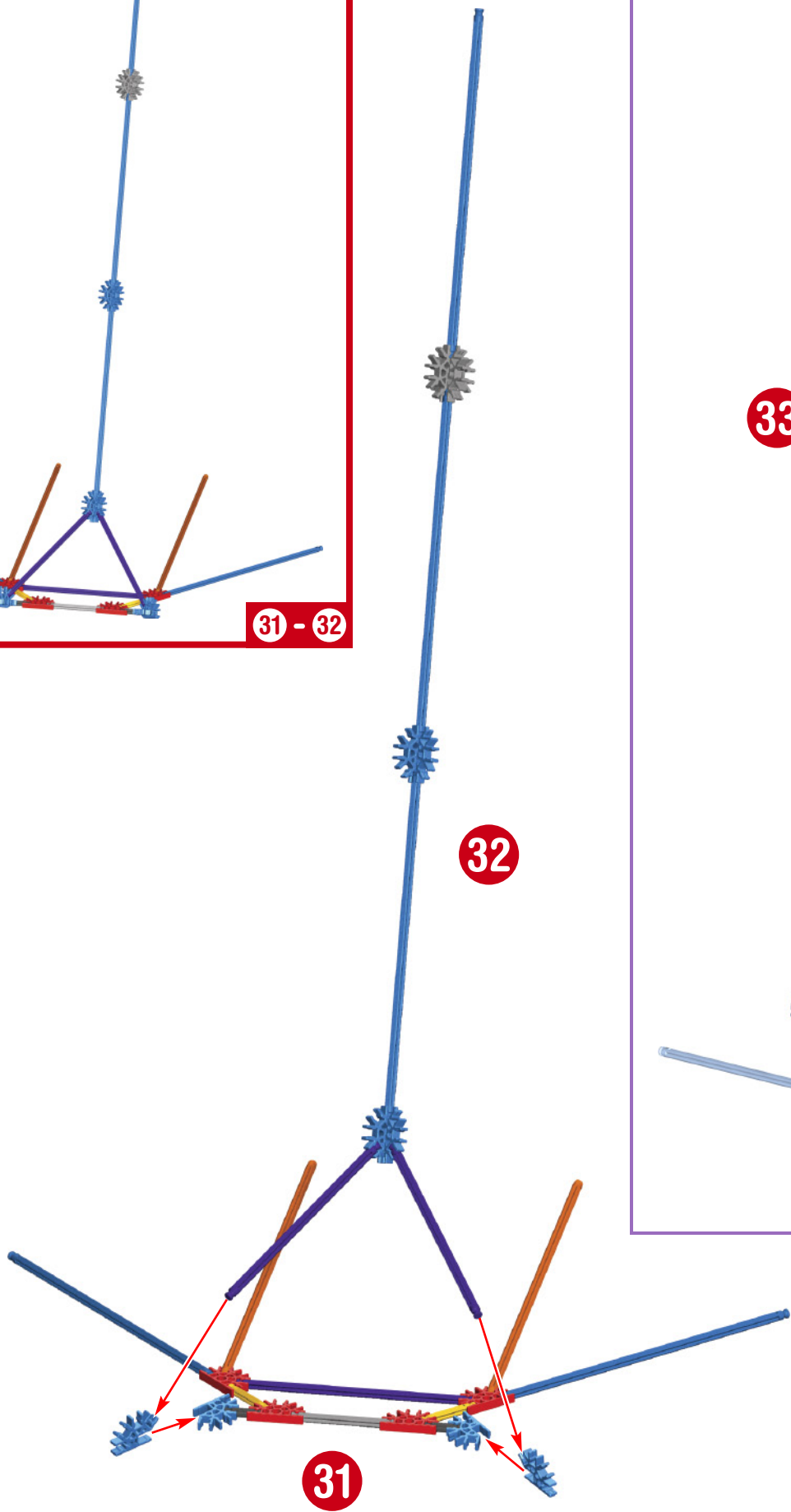
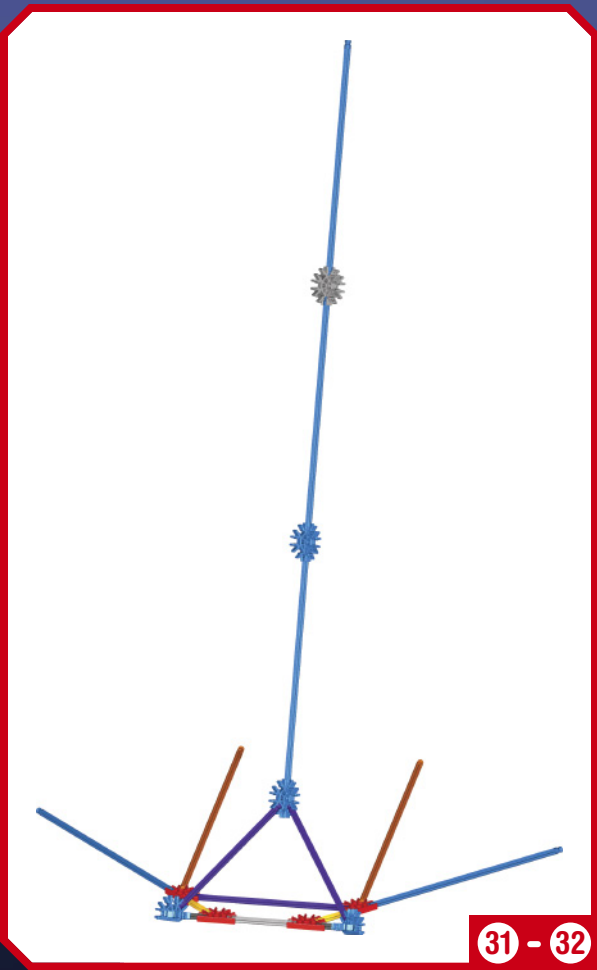

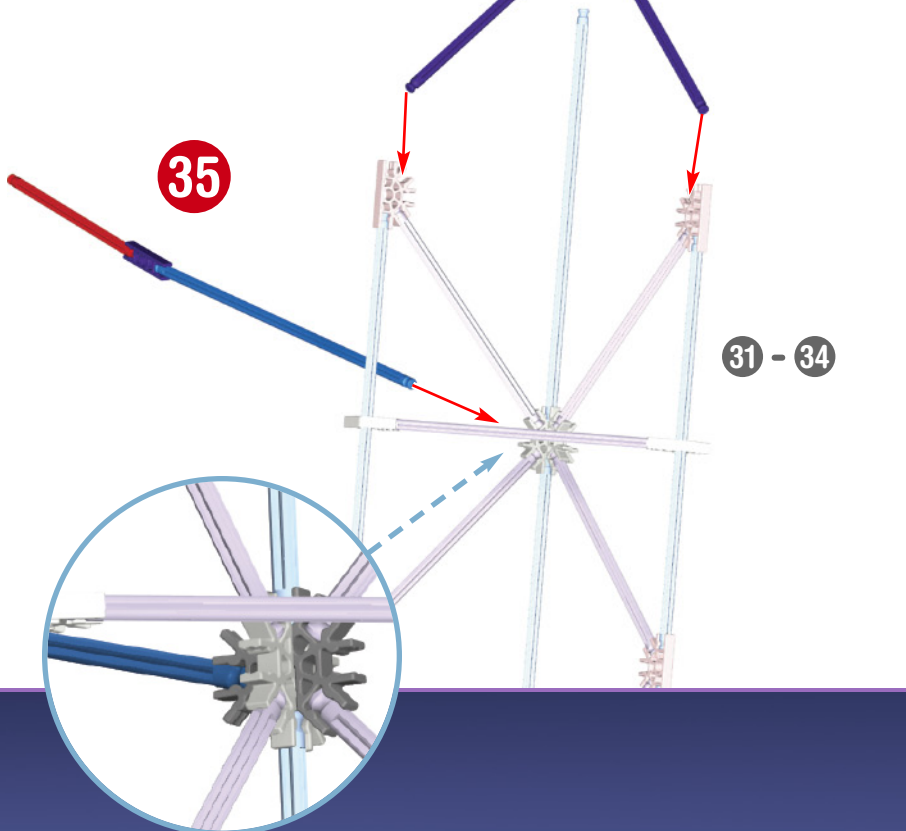
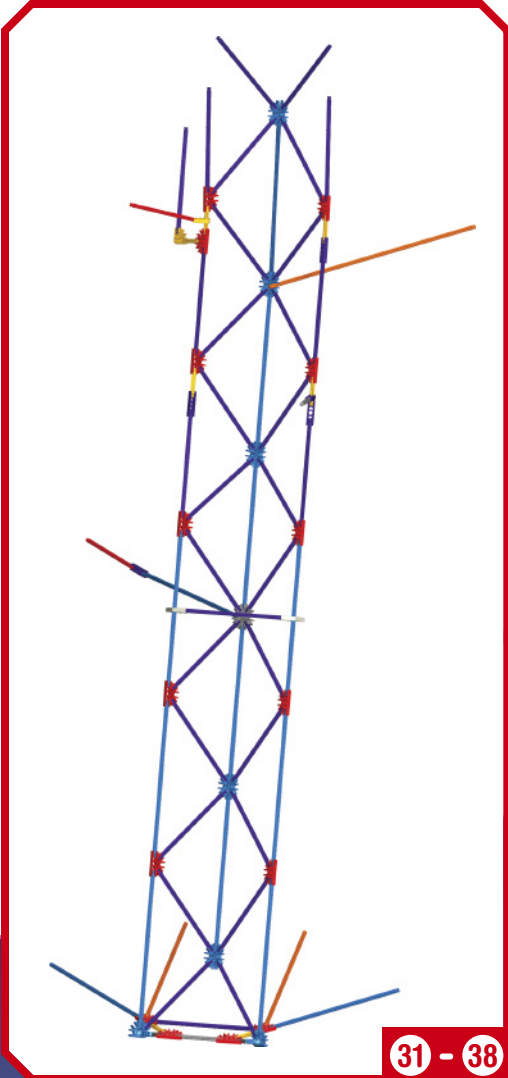
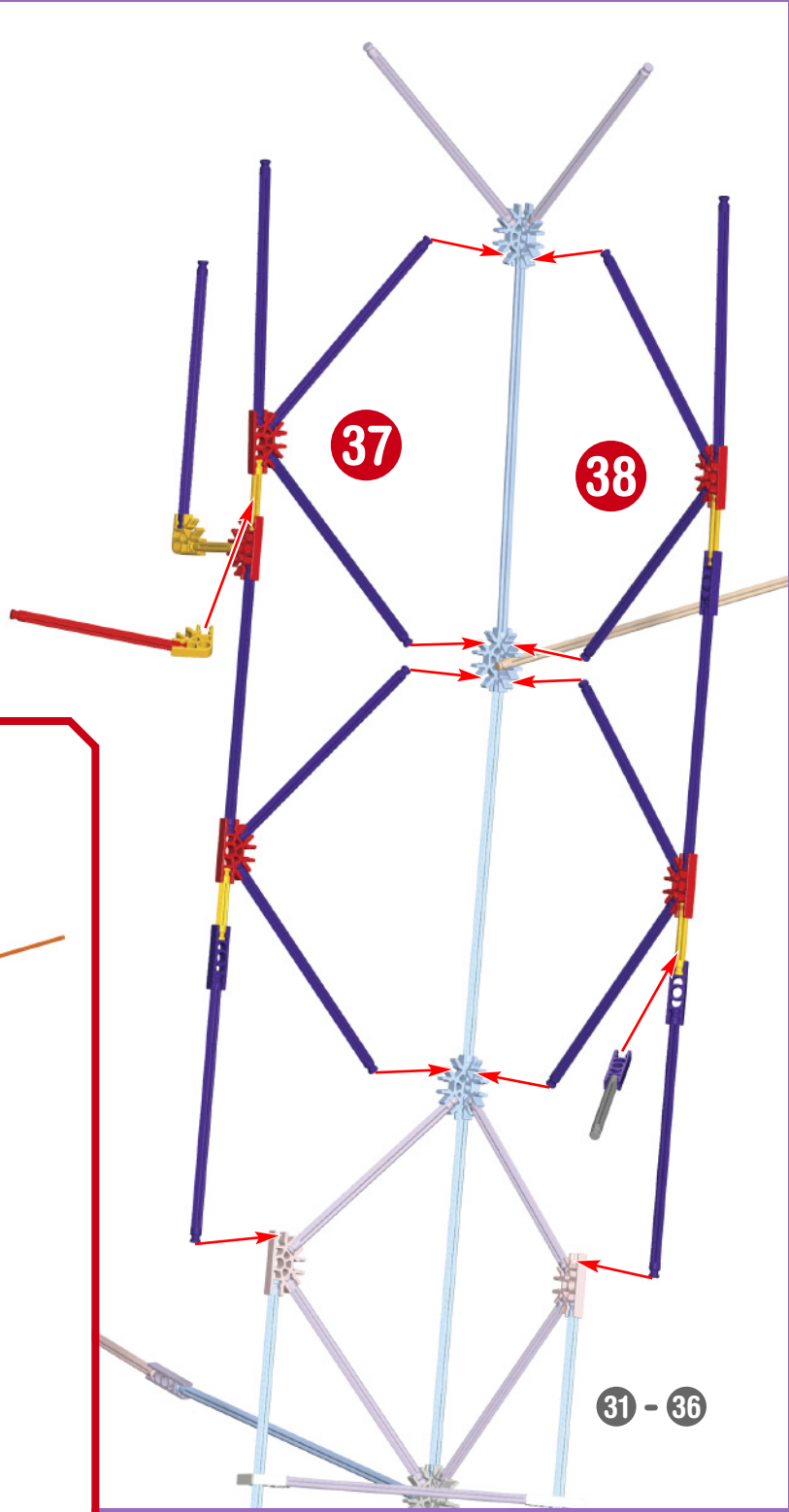
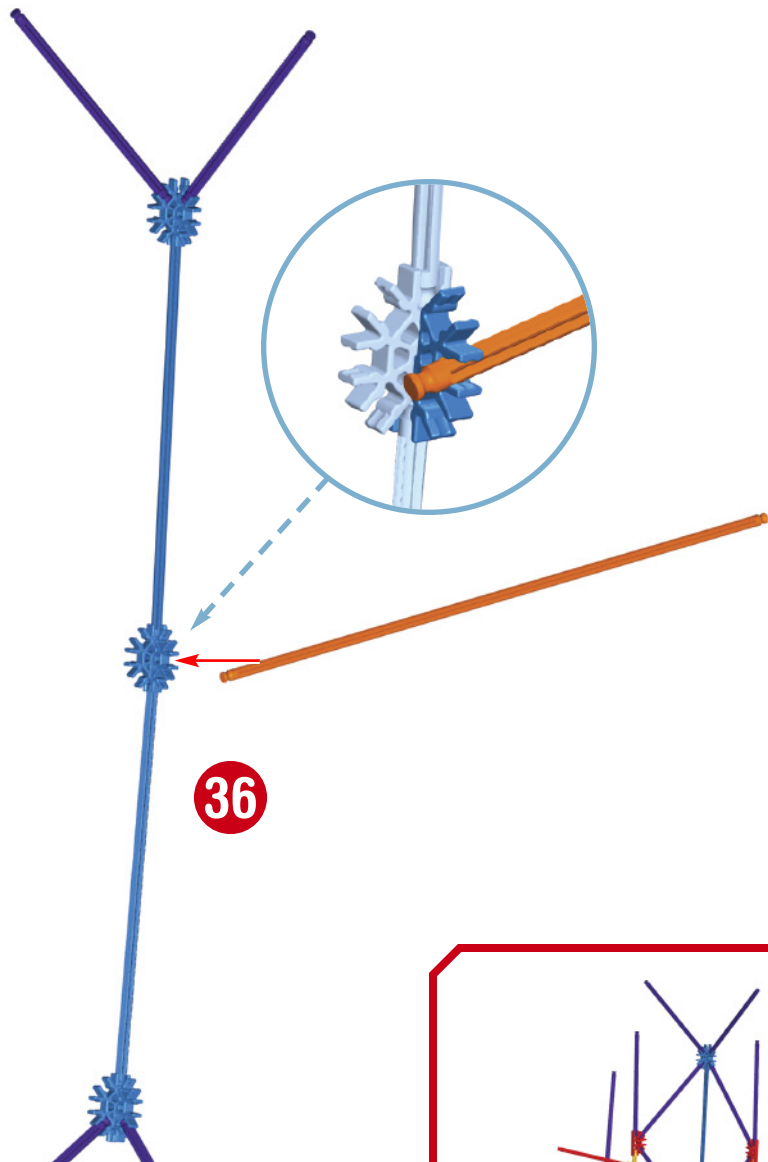
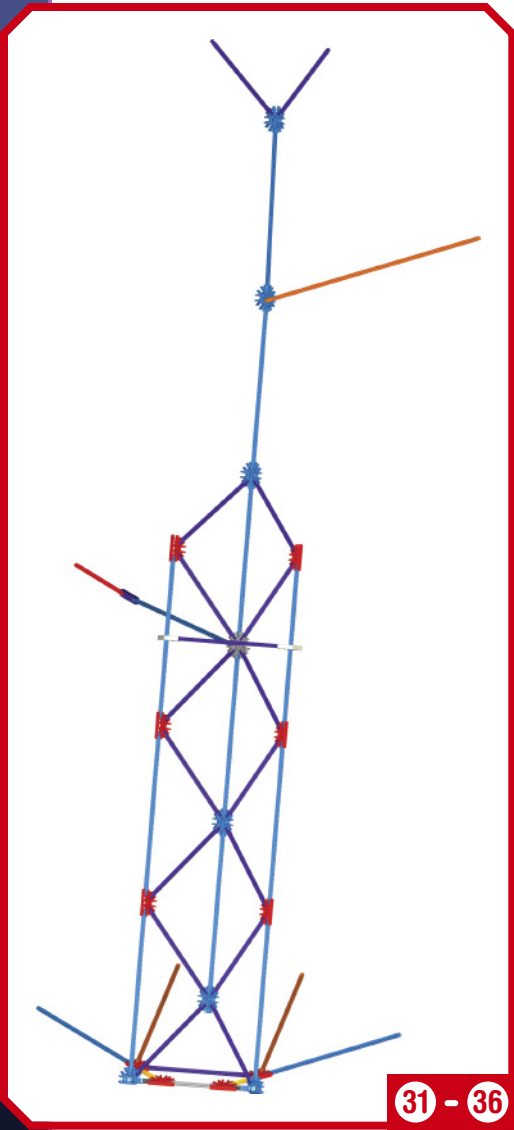

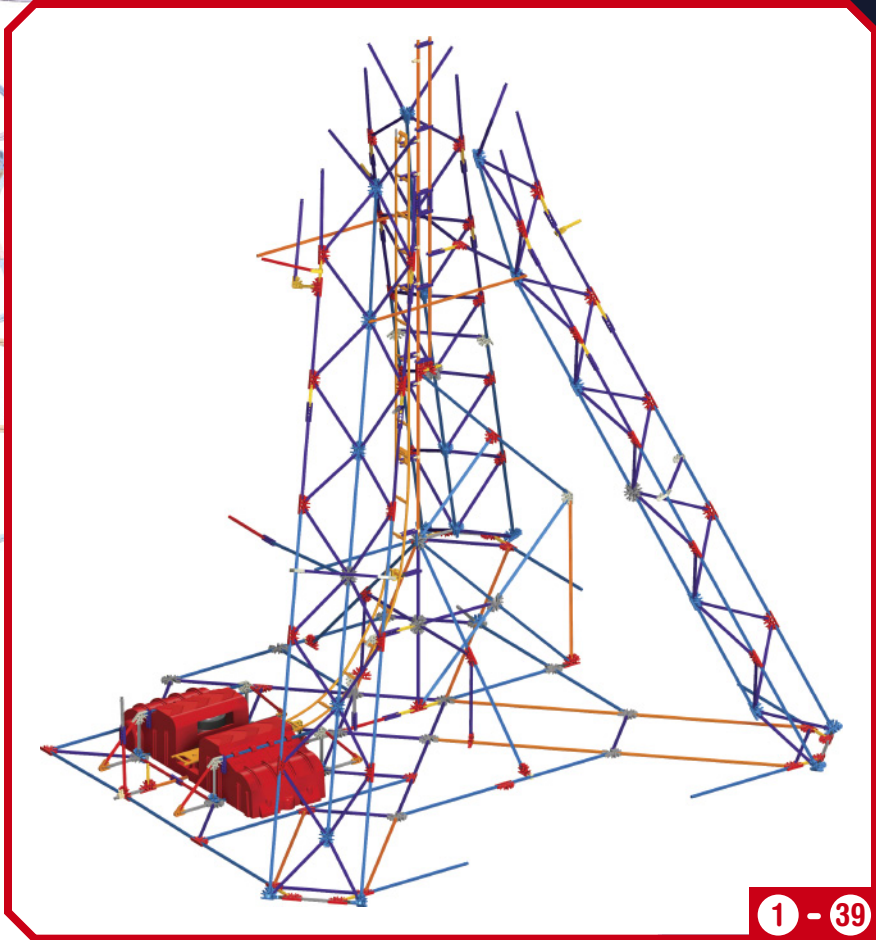
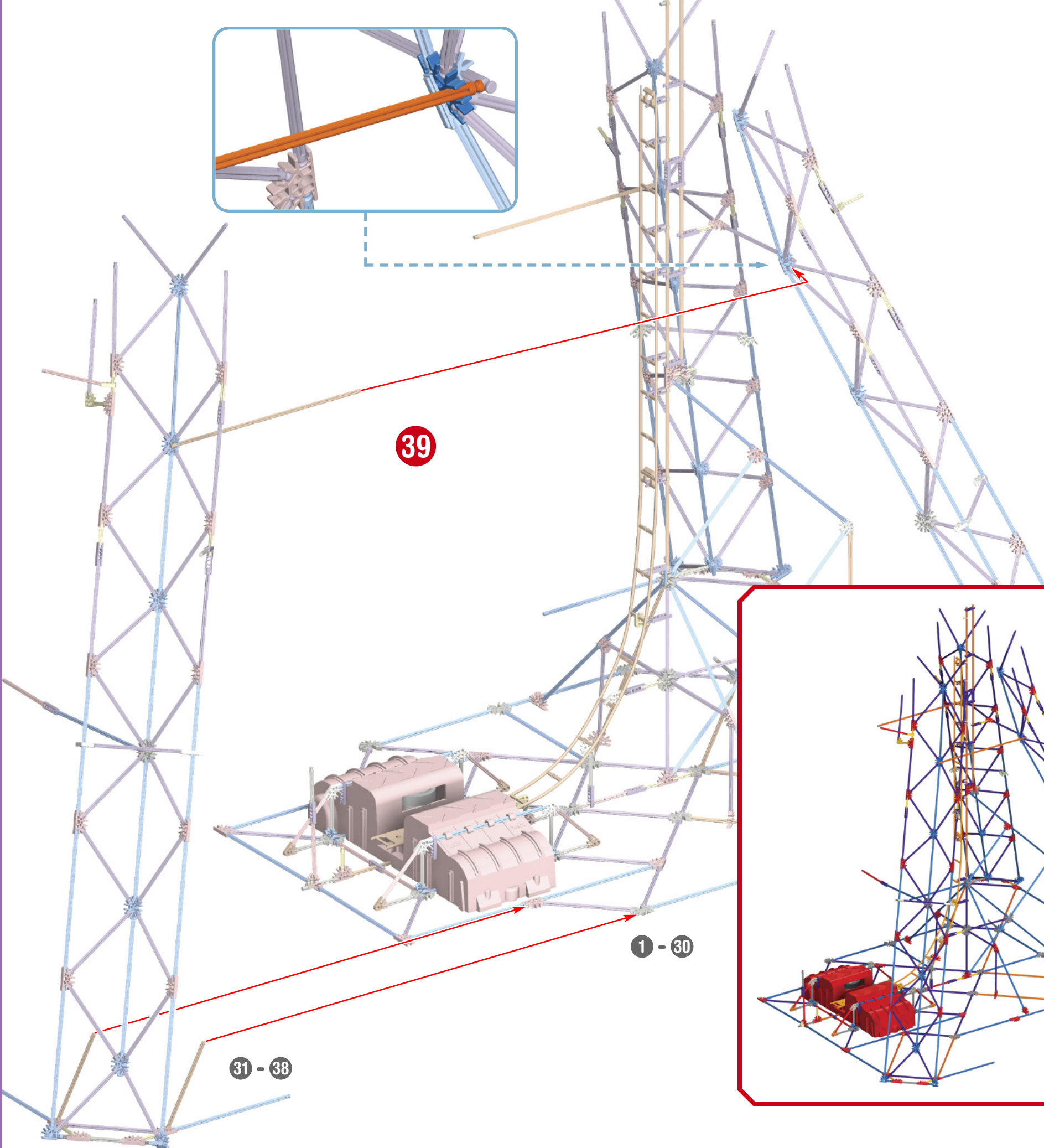
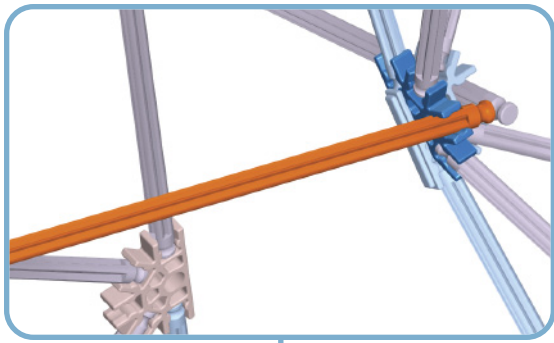

1 - 39

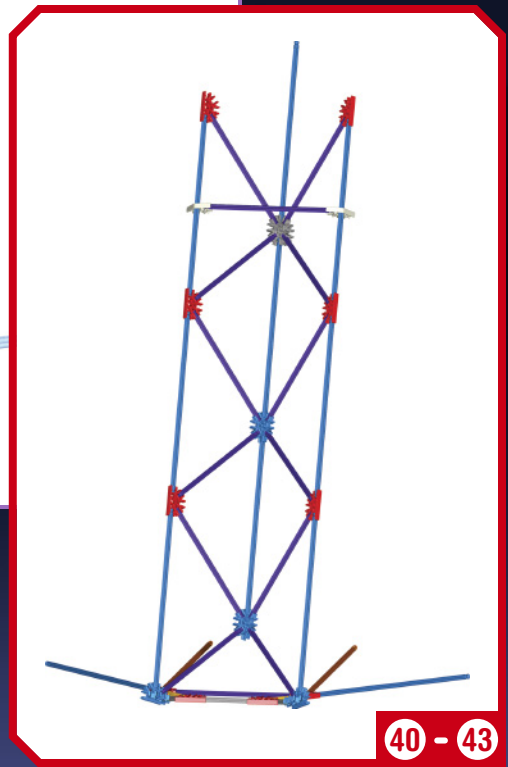
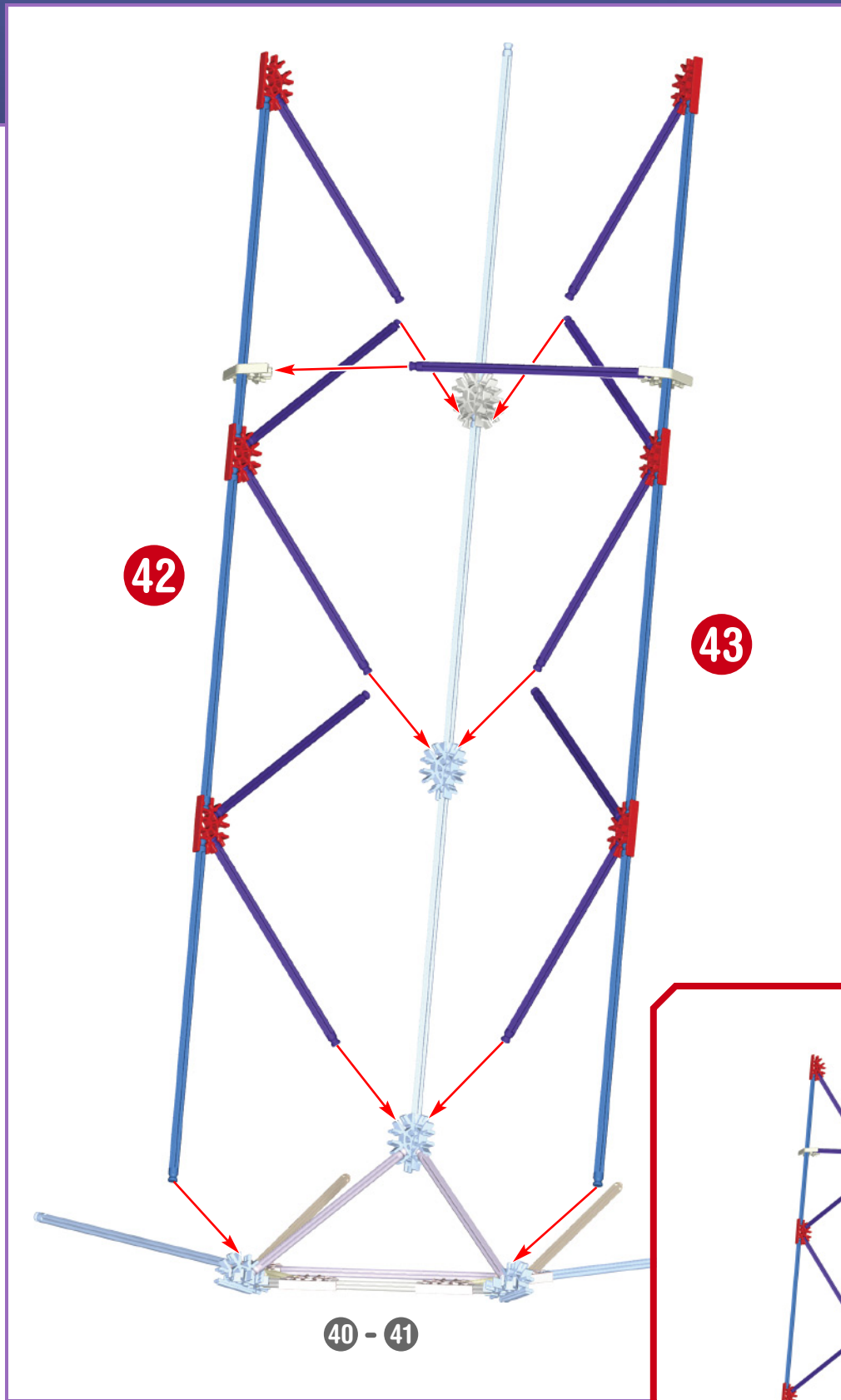
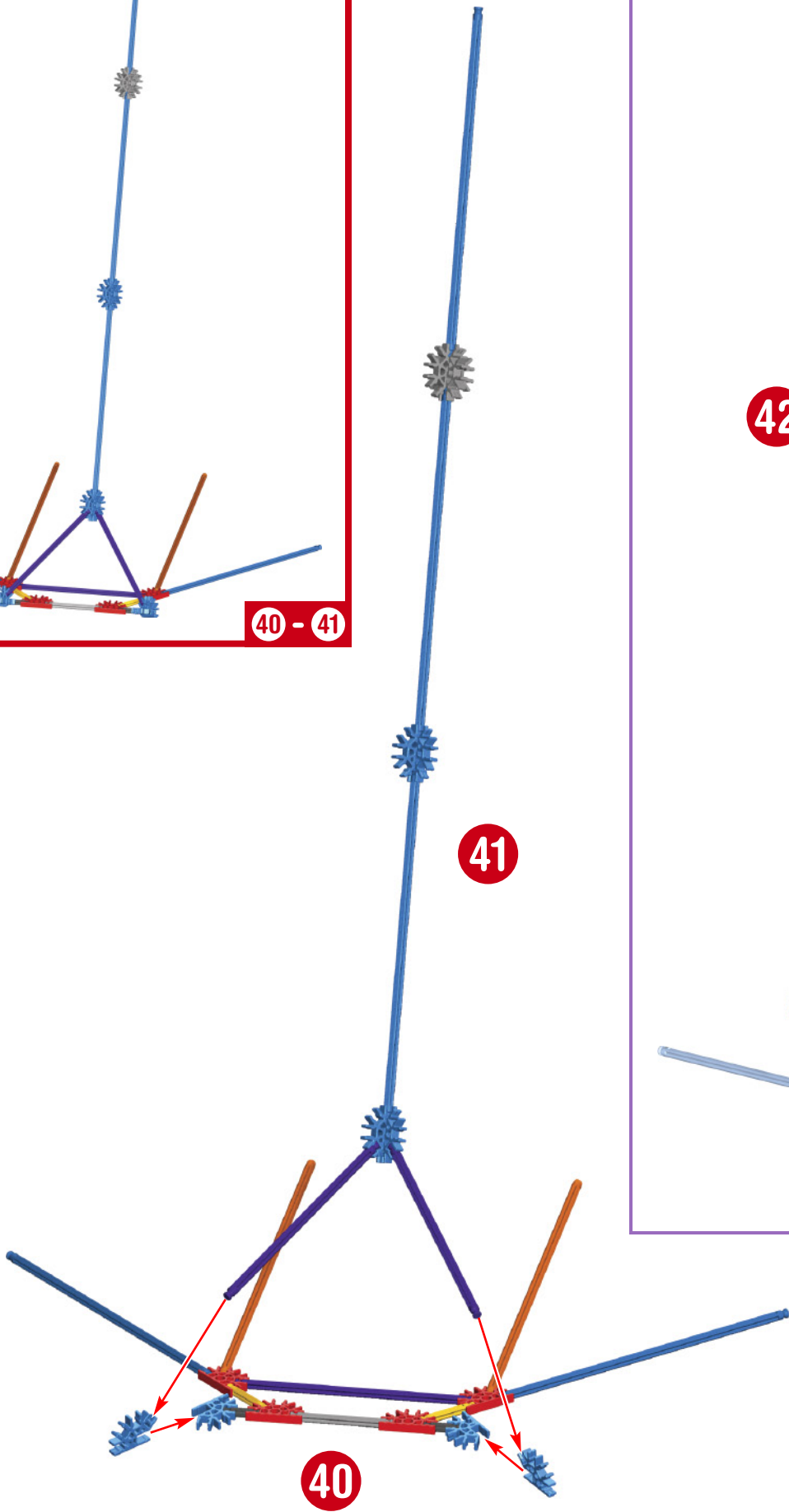
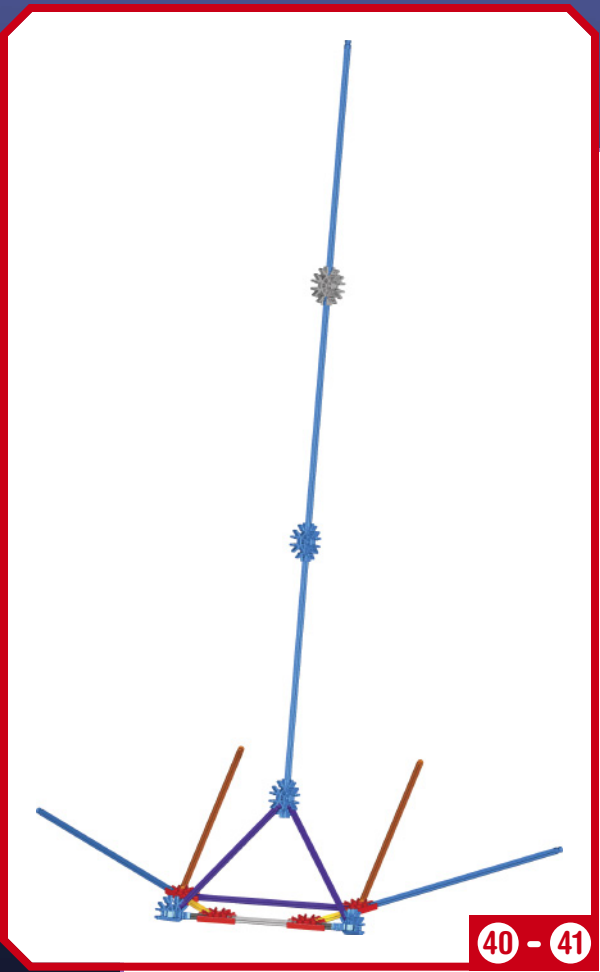

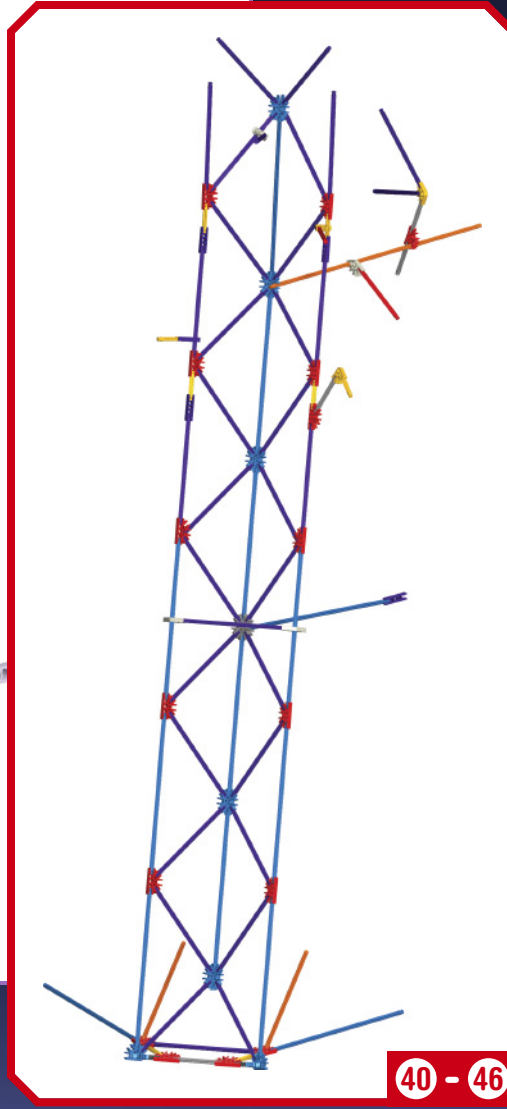
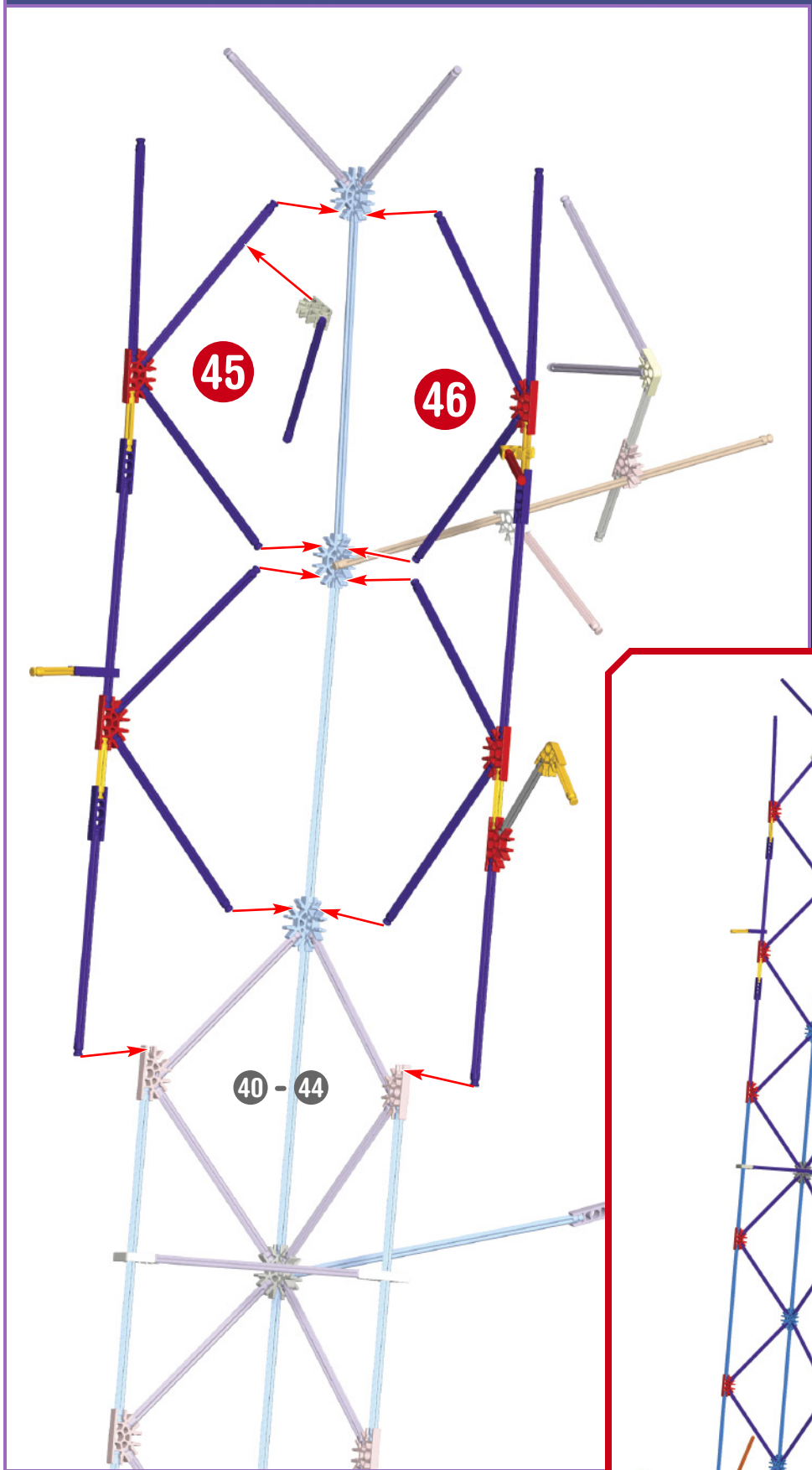
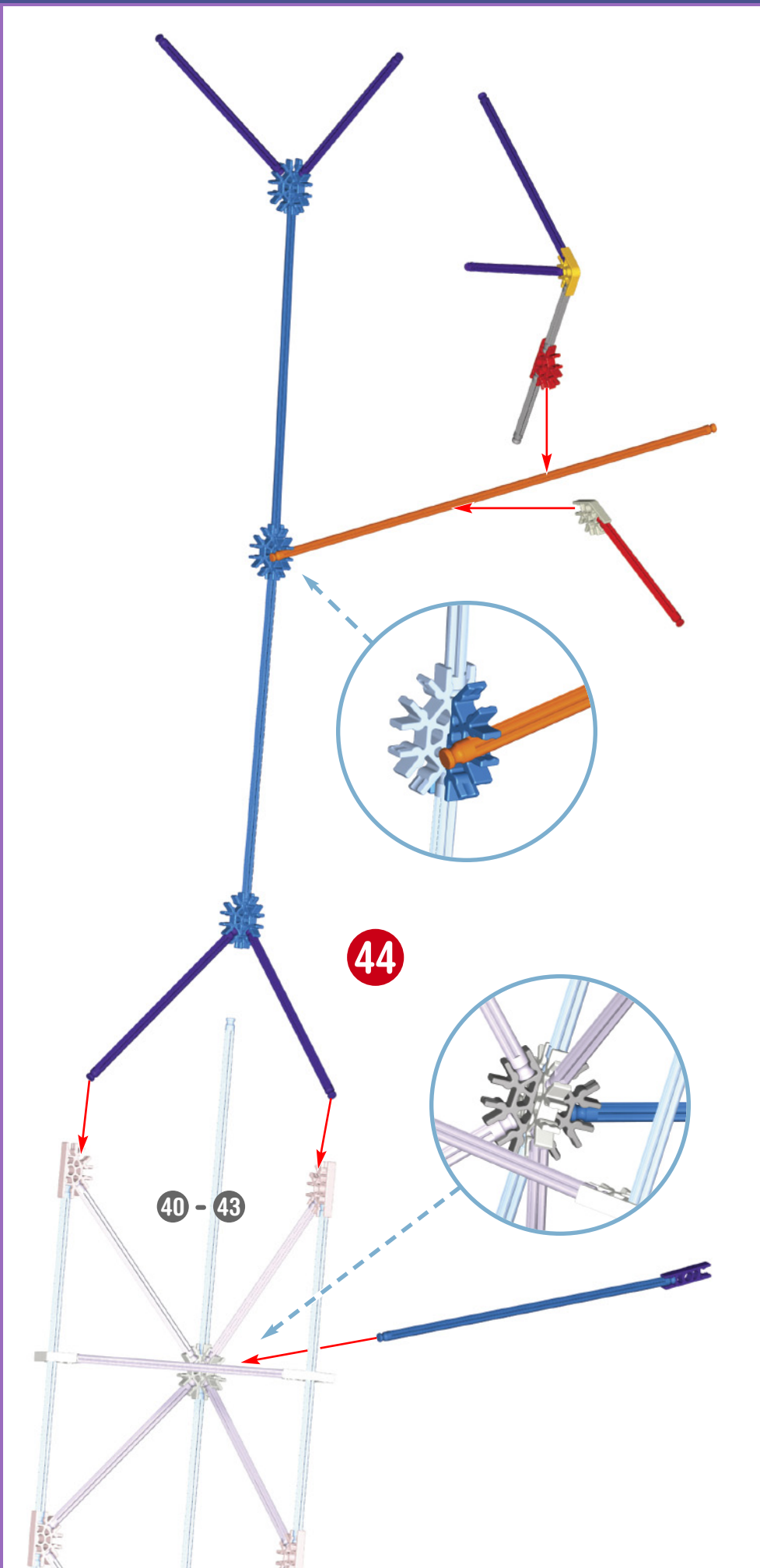

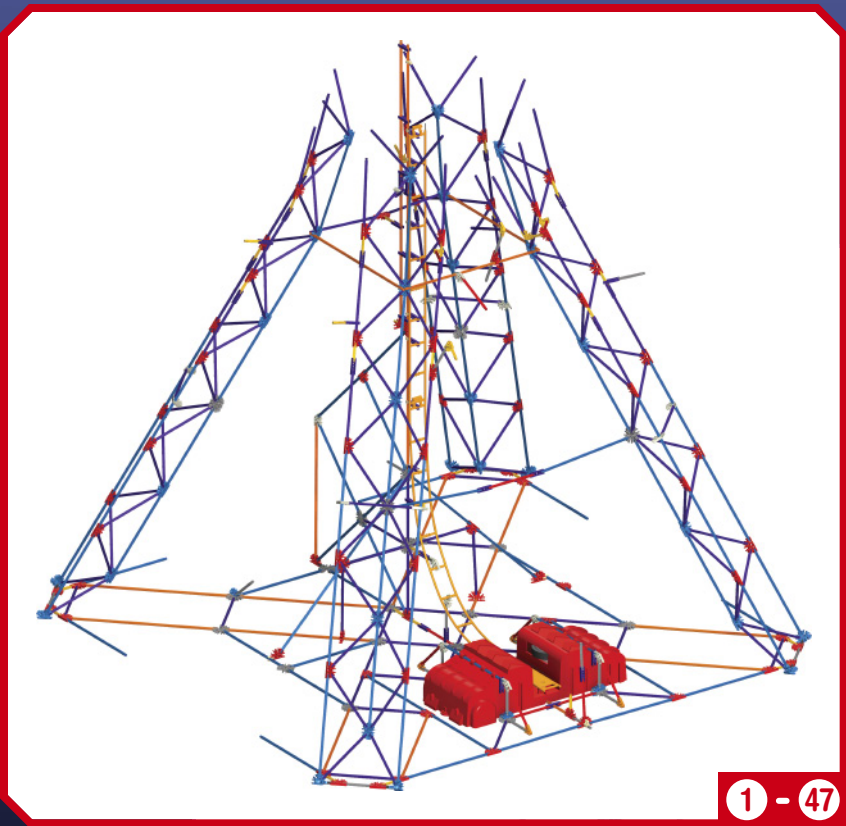

1 - 47

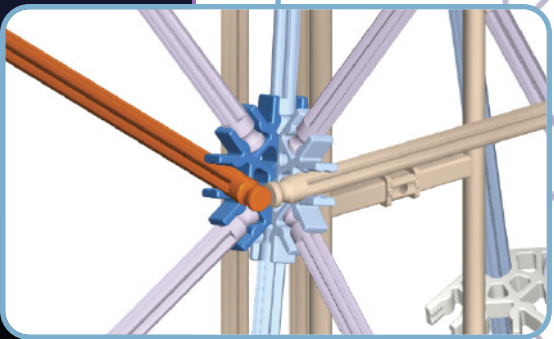
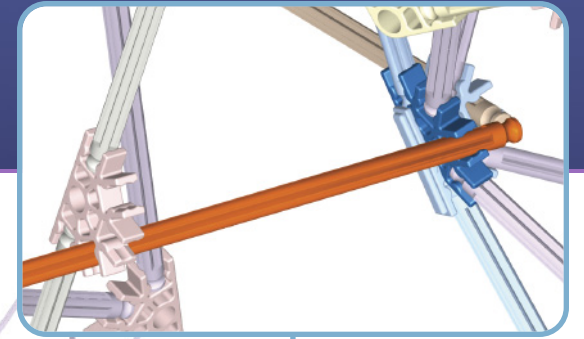

47

40 - 46

1 - 39

x3

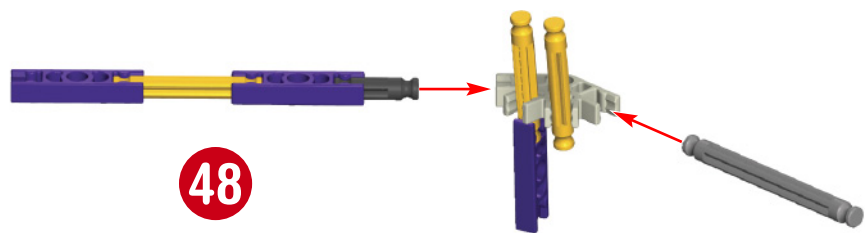

48

x1

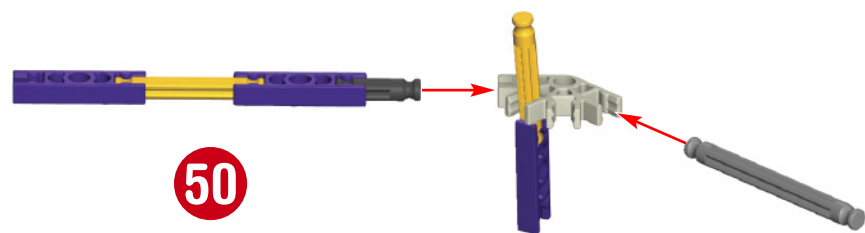

50

x3

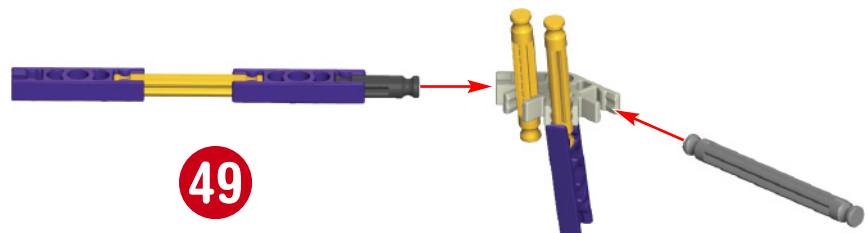

49

x1

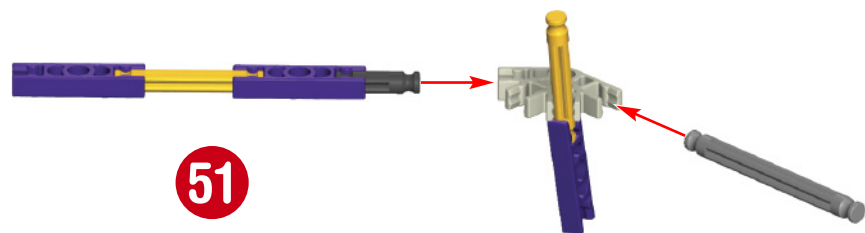

51

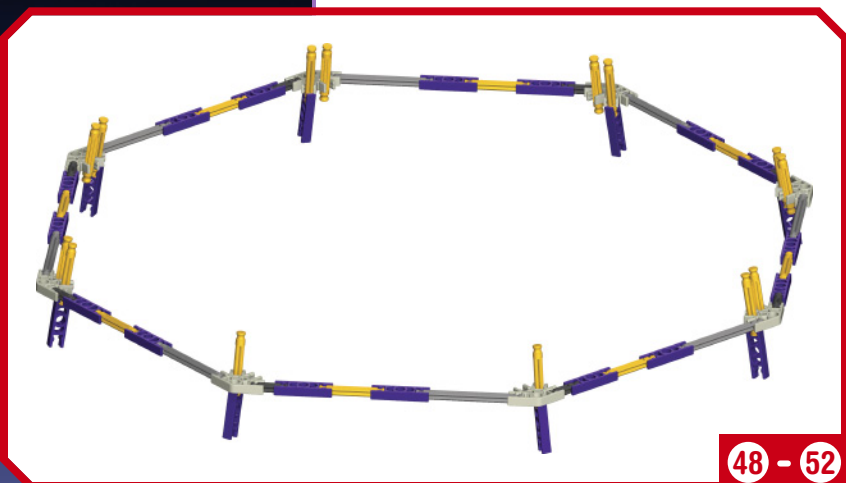
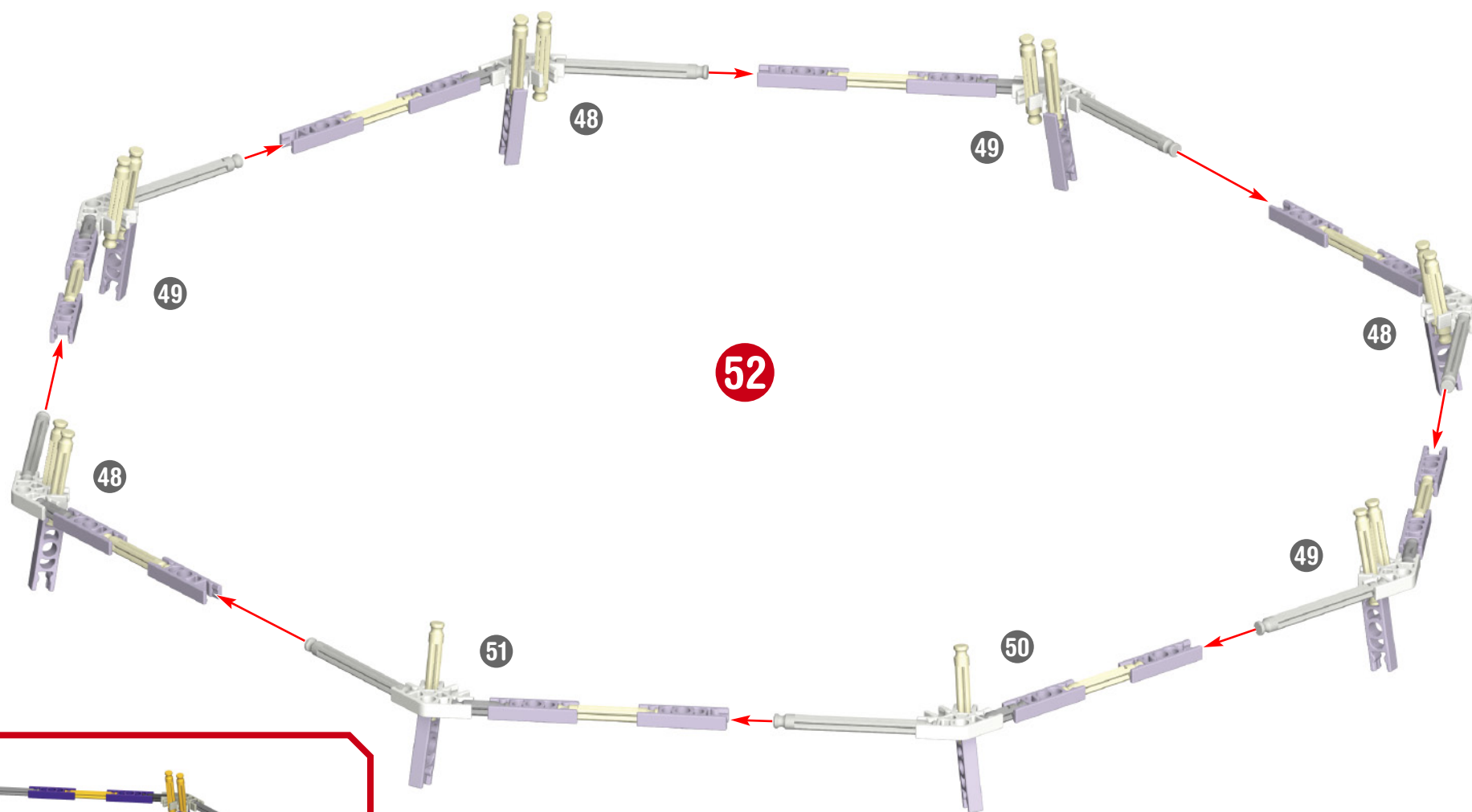

48 - 52

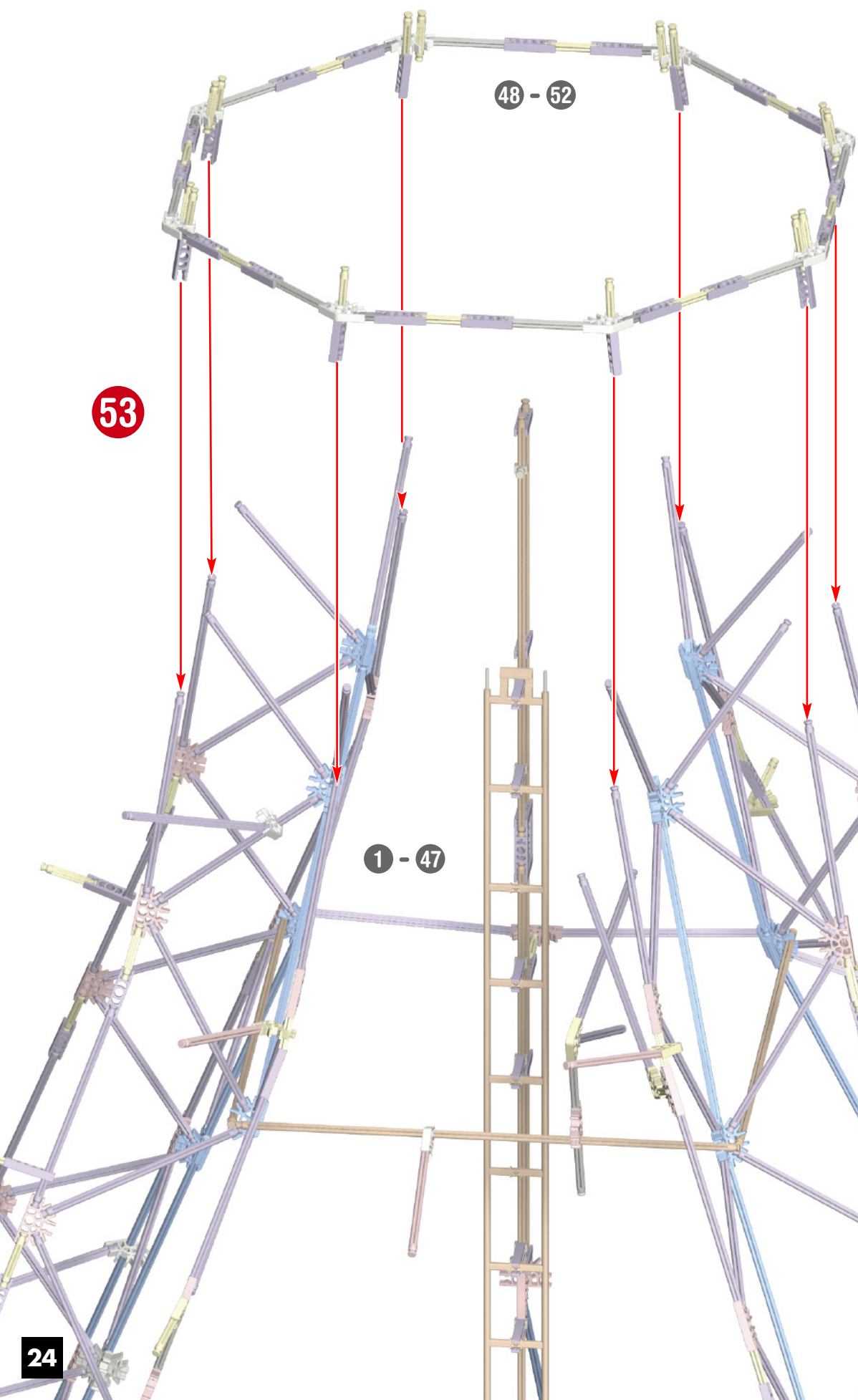

53

48 - 52

1 - 47

24

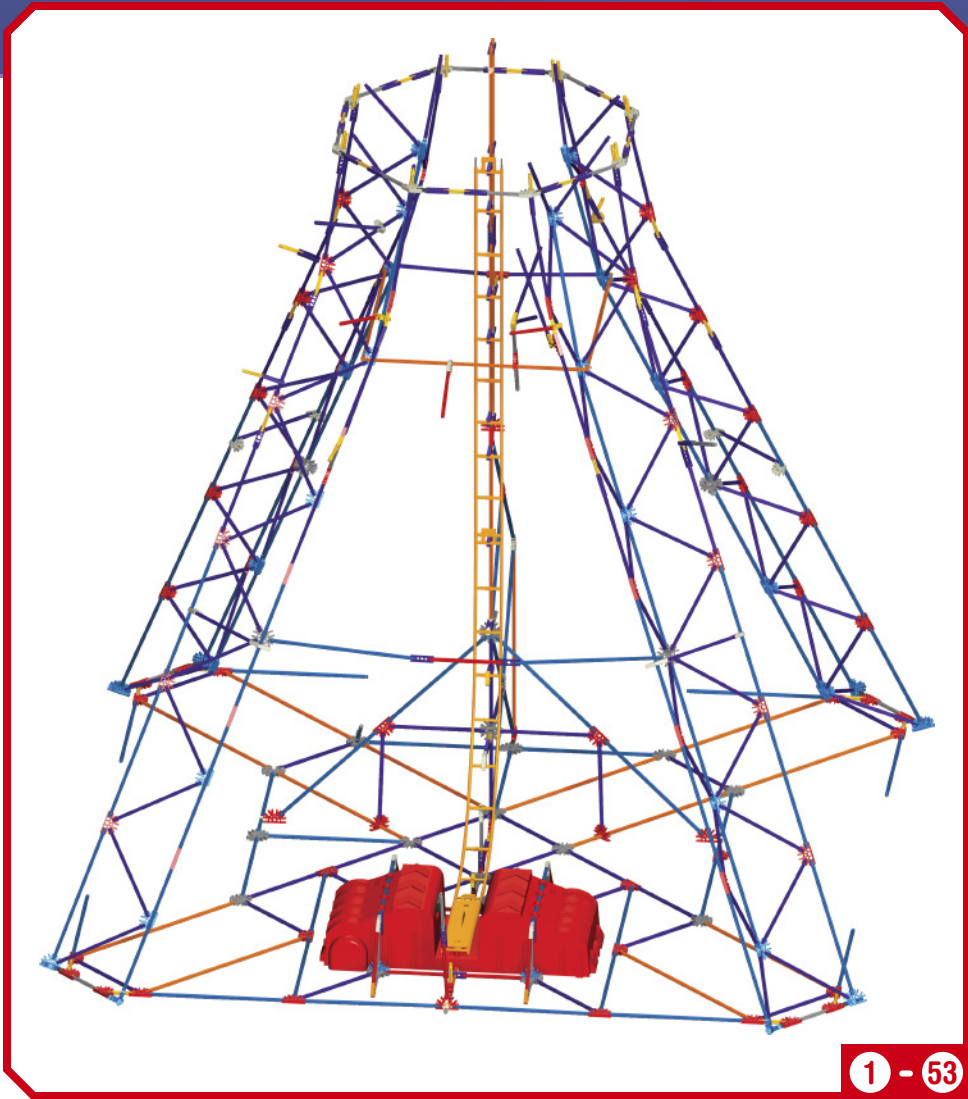

1 - 53

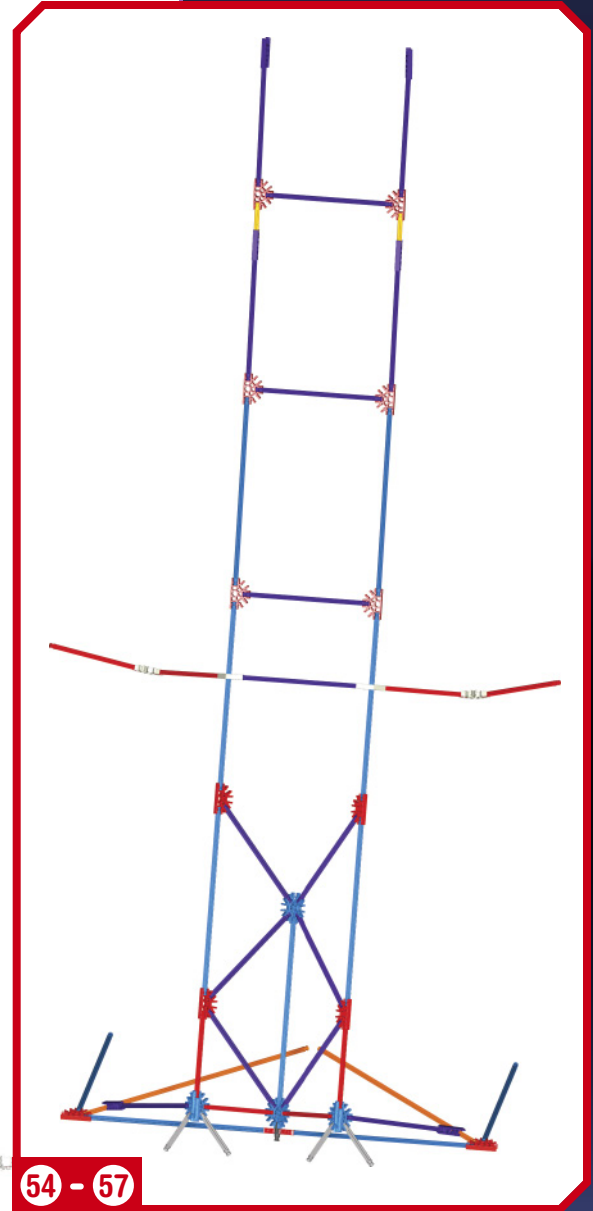
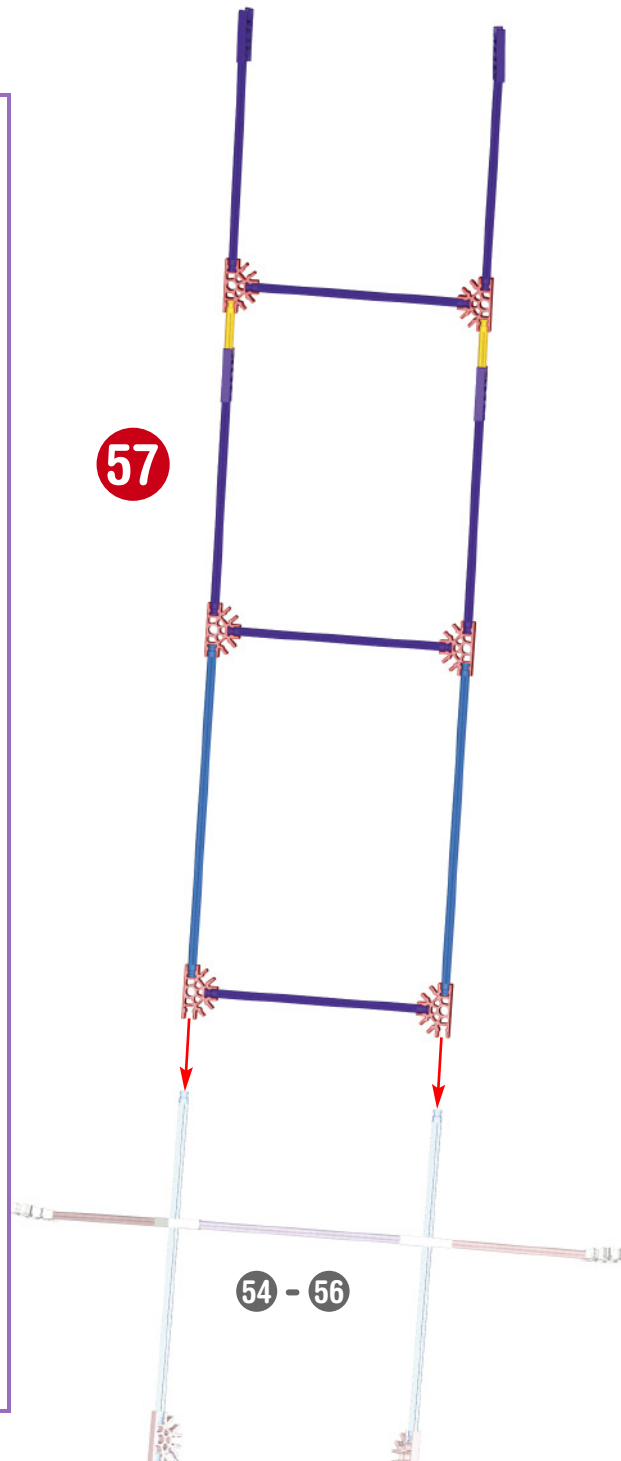
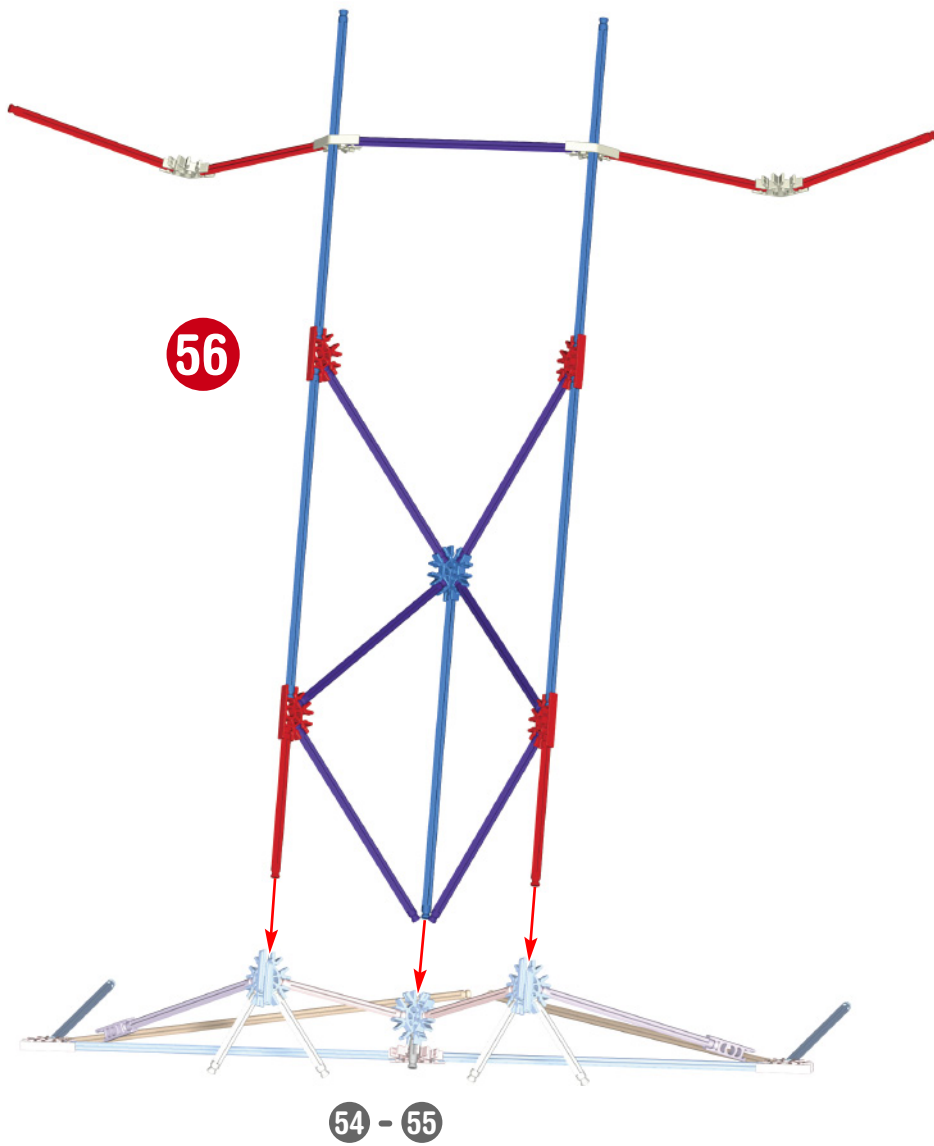
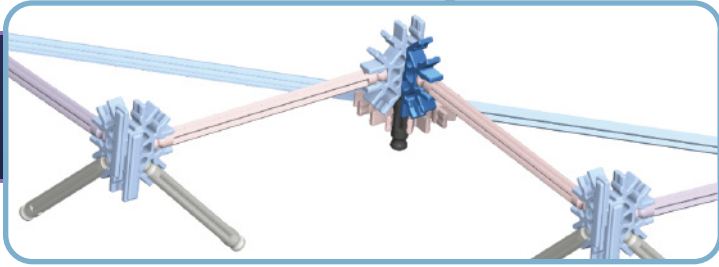
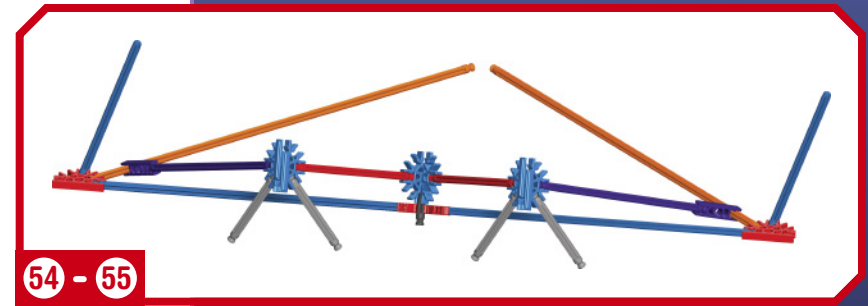
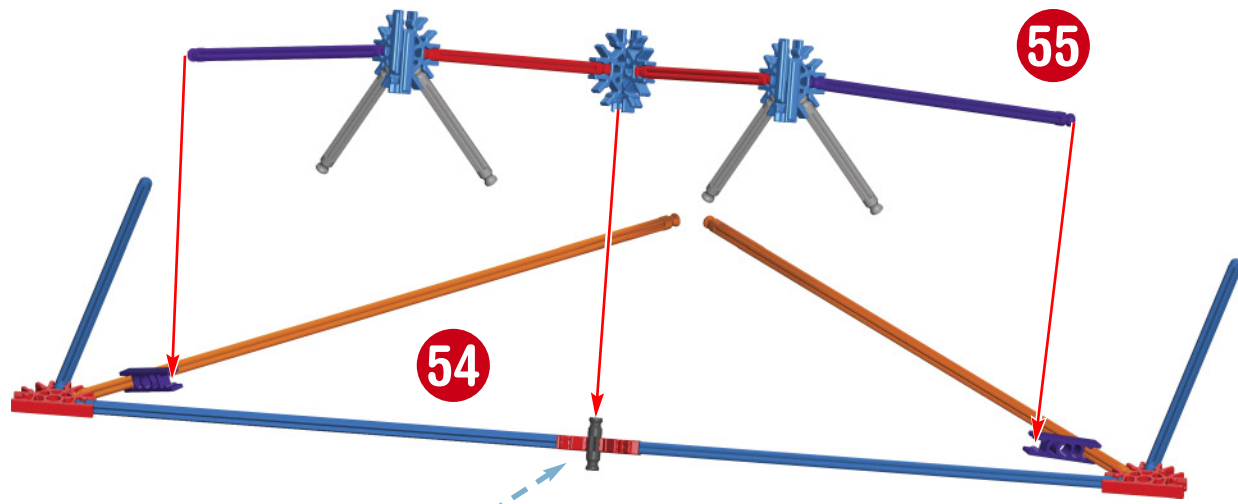

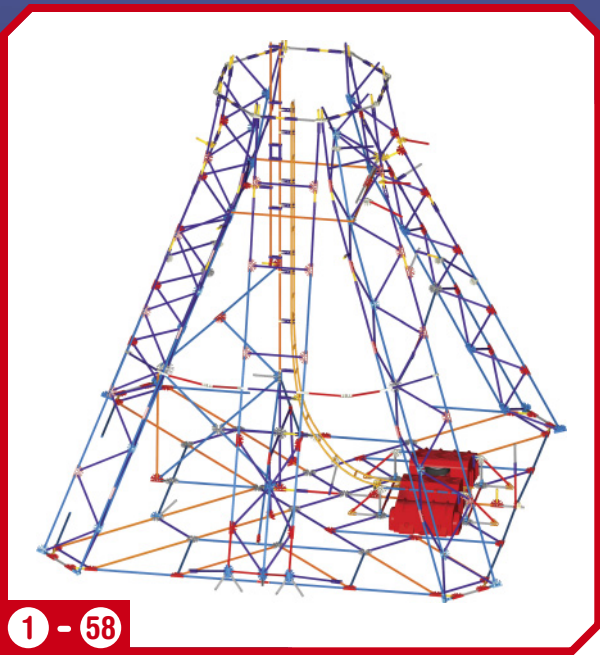

1 - 58

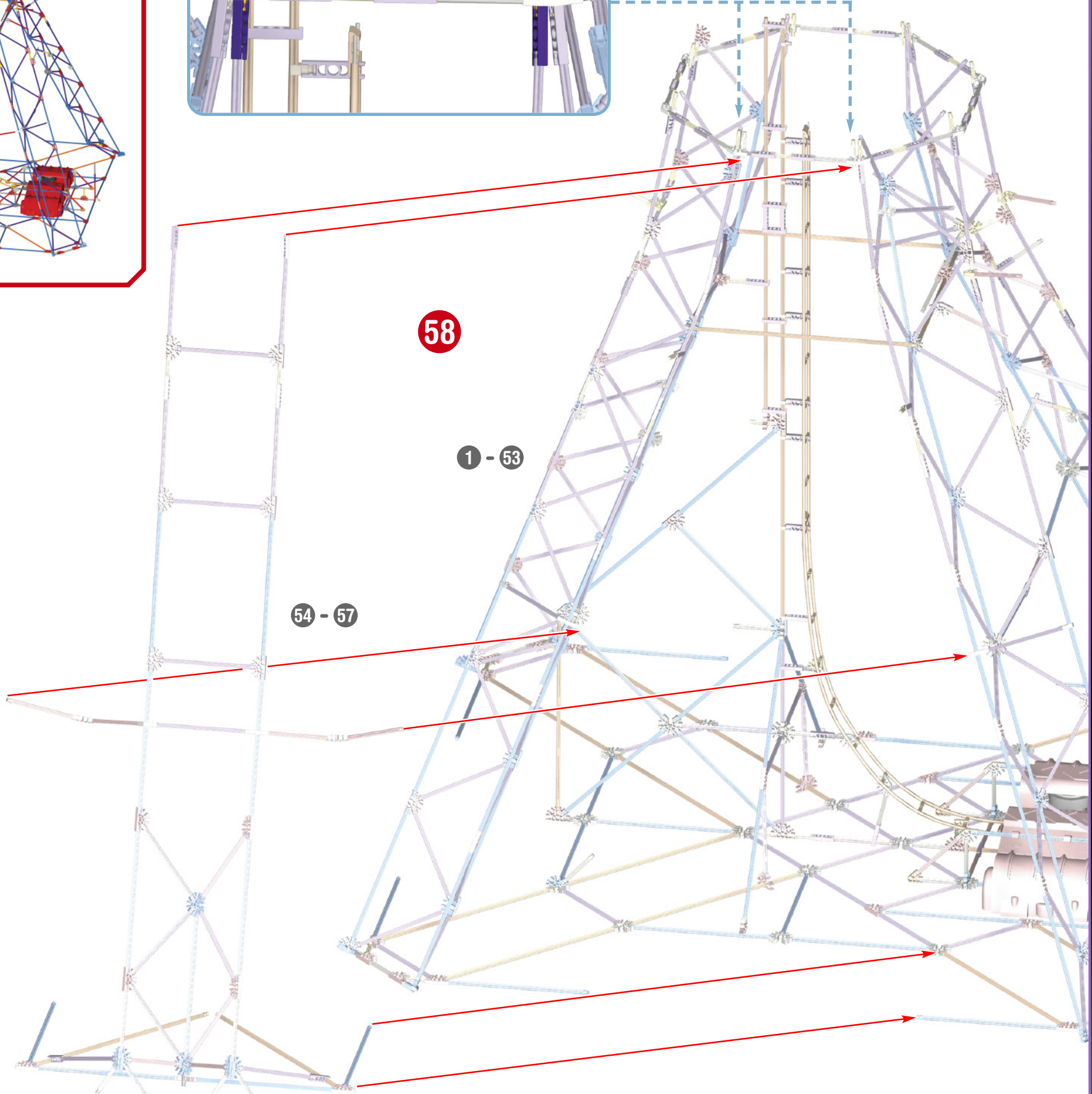
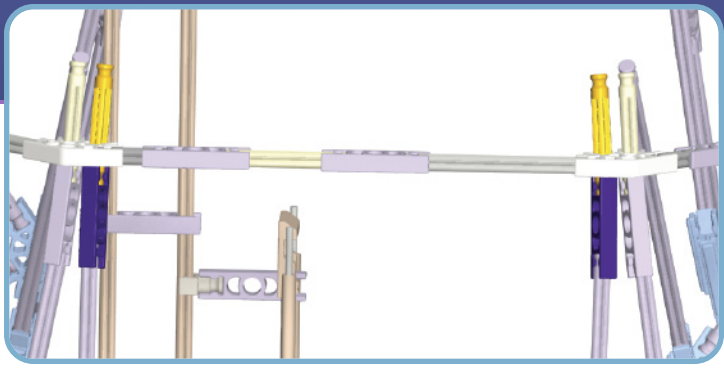

58

1 - 53

54 - 57

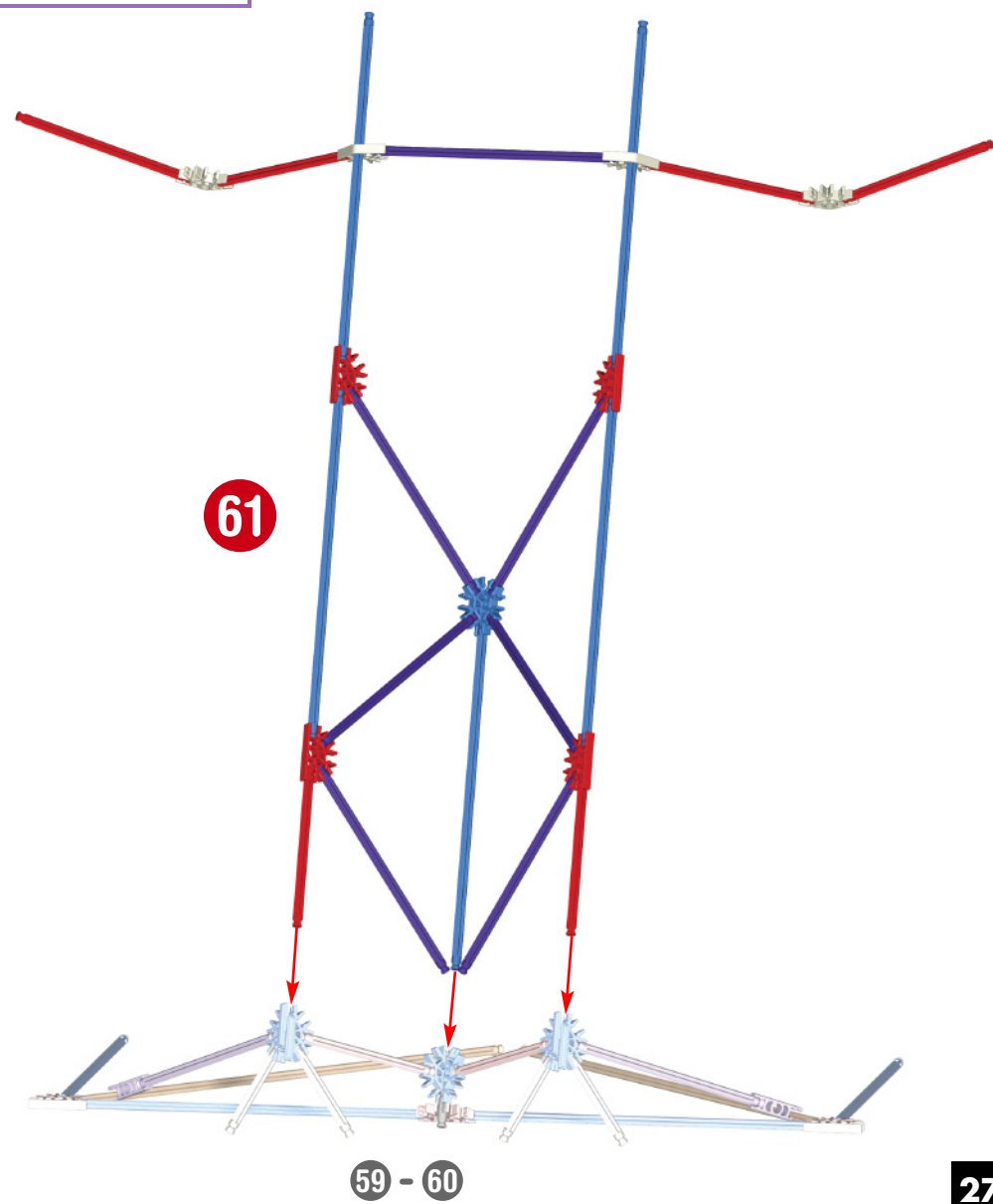
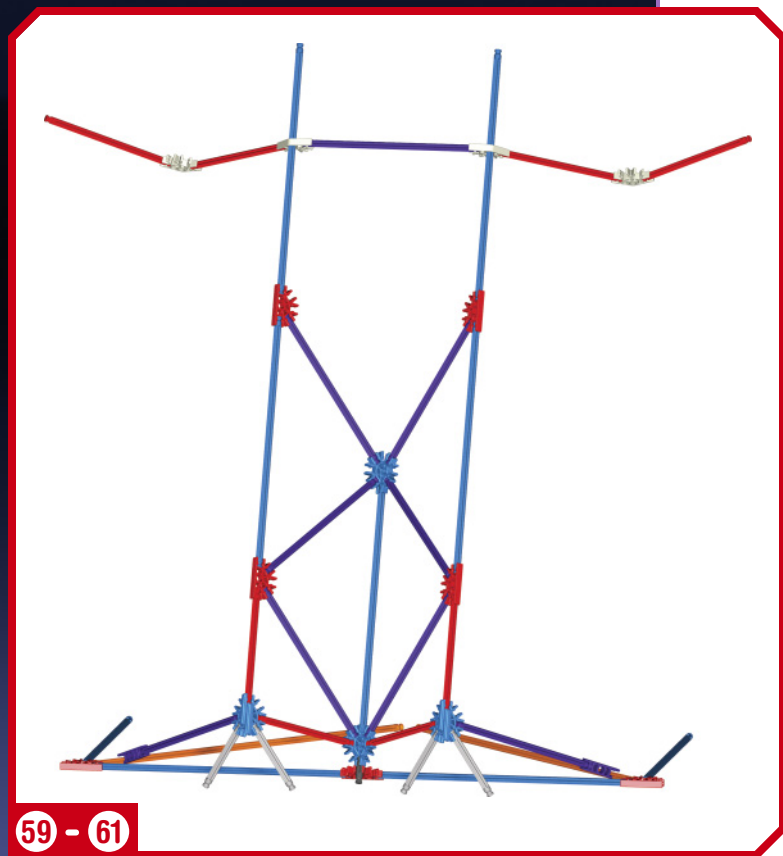
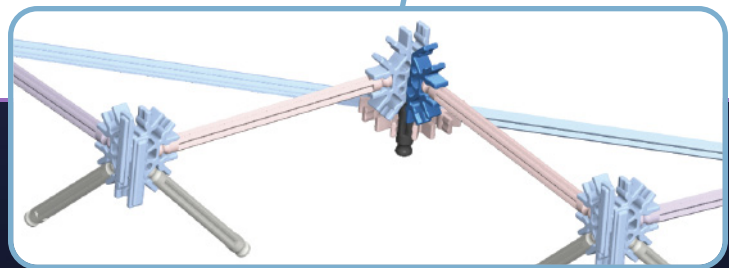
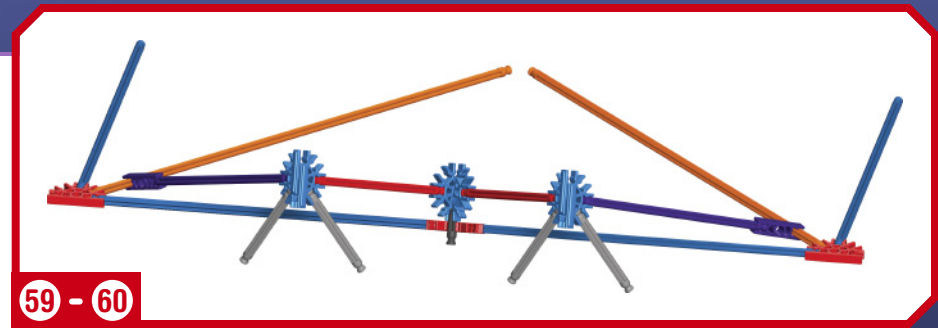
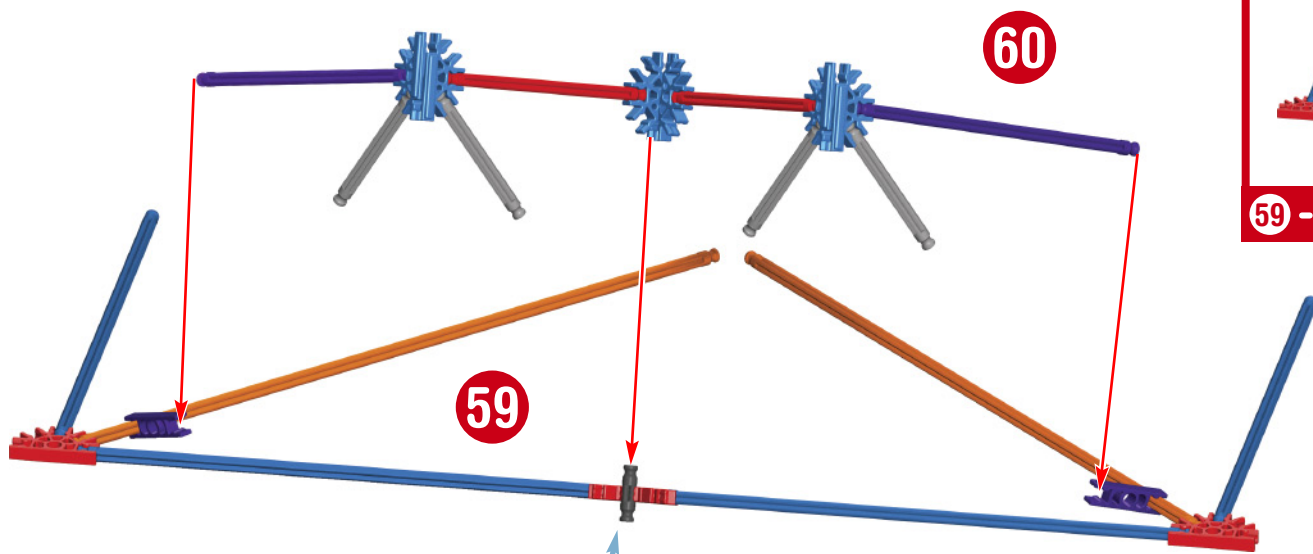

62

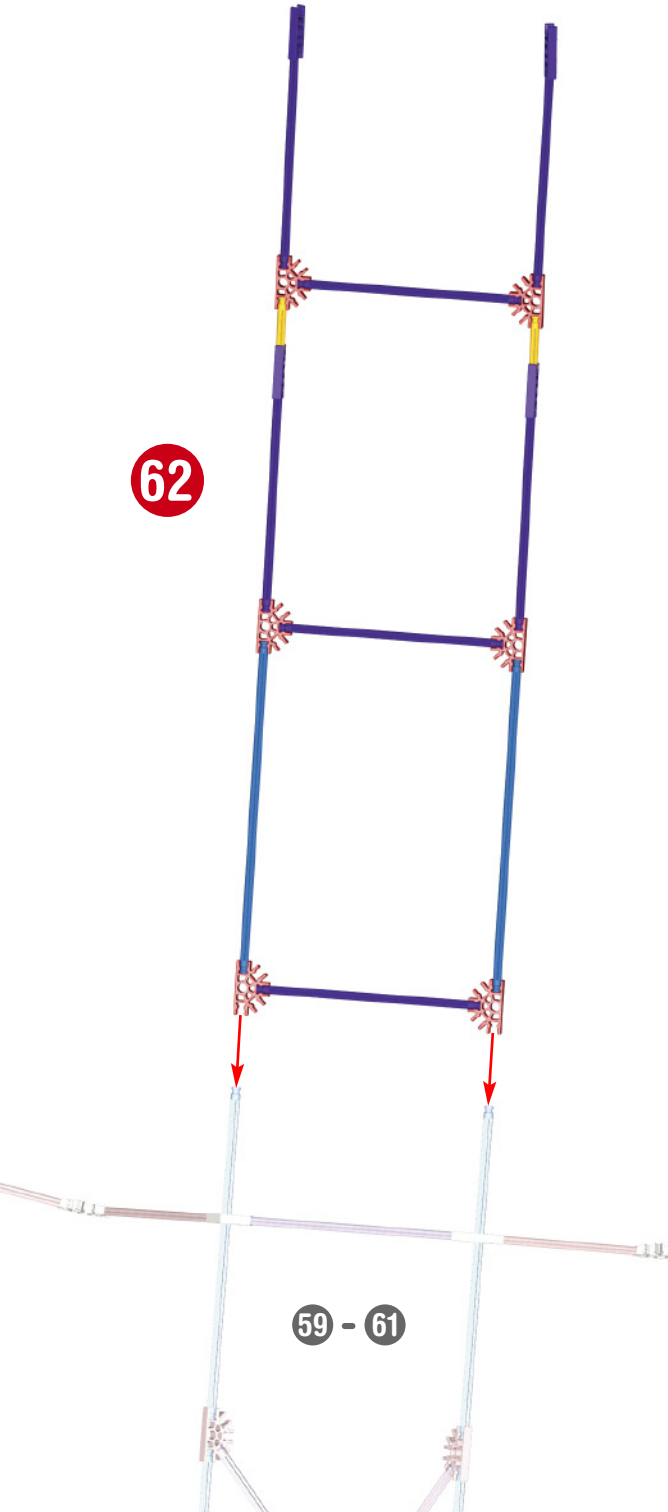

59 - 61

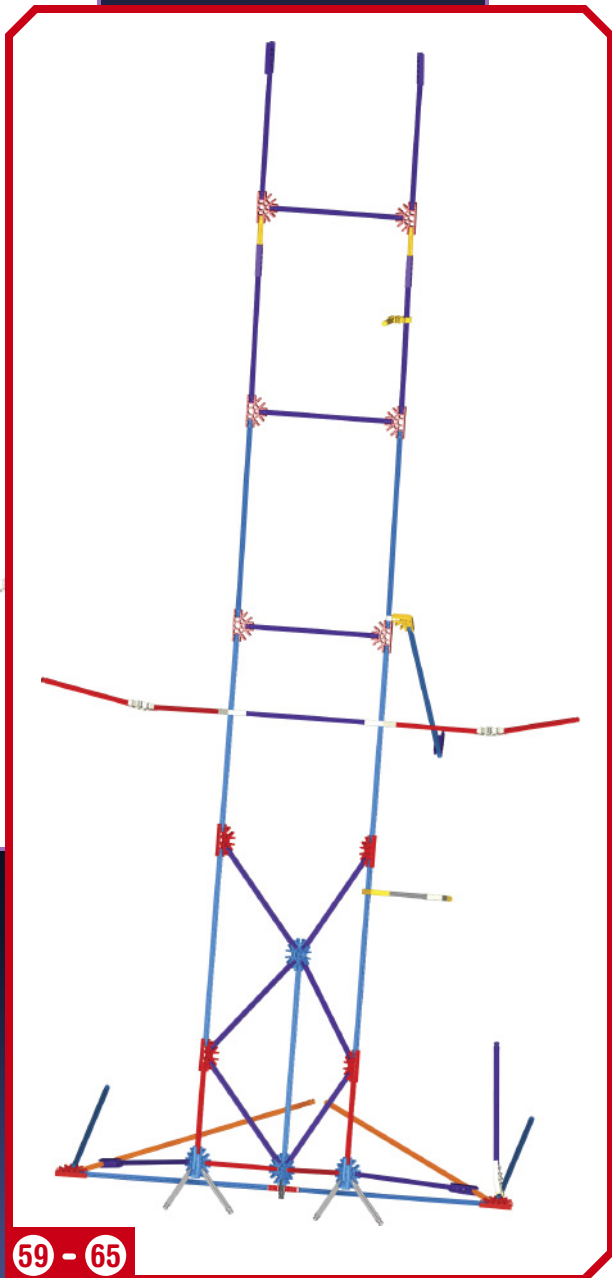

59 - 65

65

64

59 - 62

63

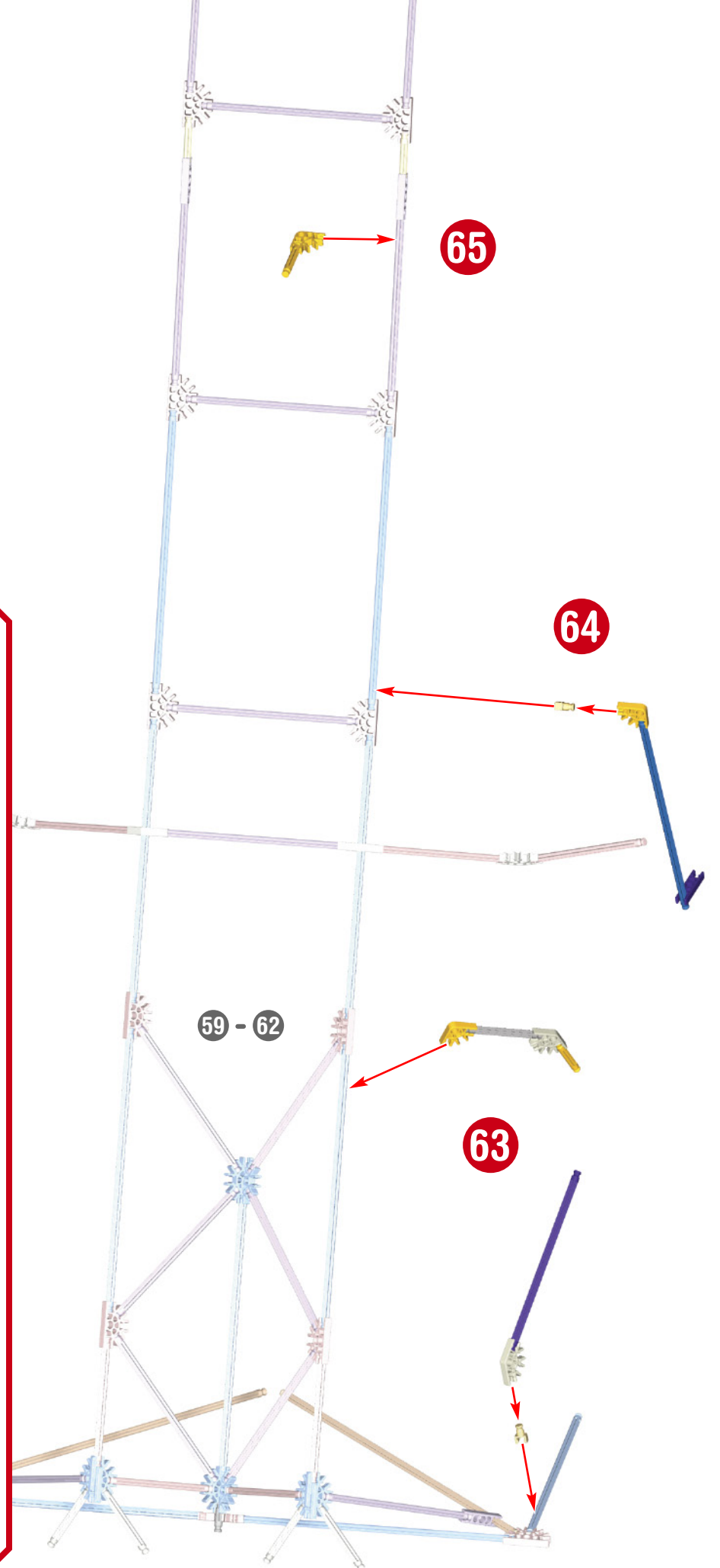

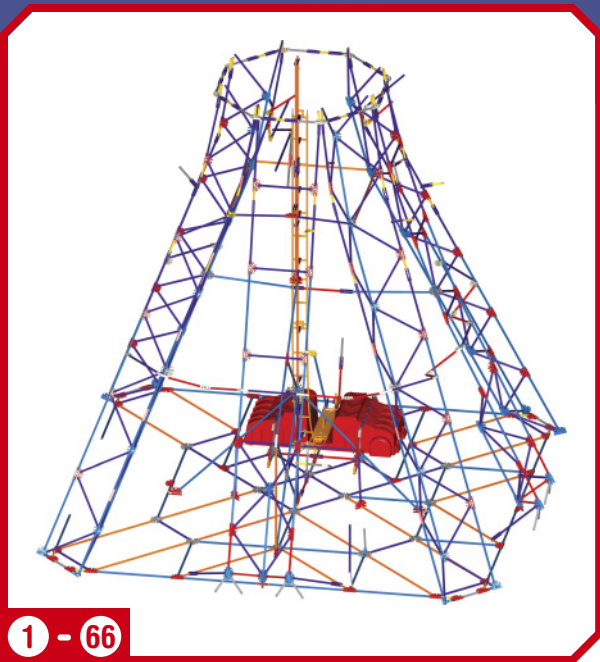

1 - 66

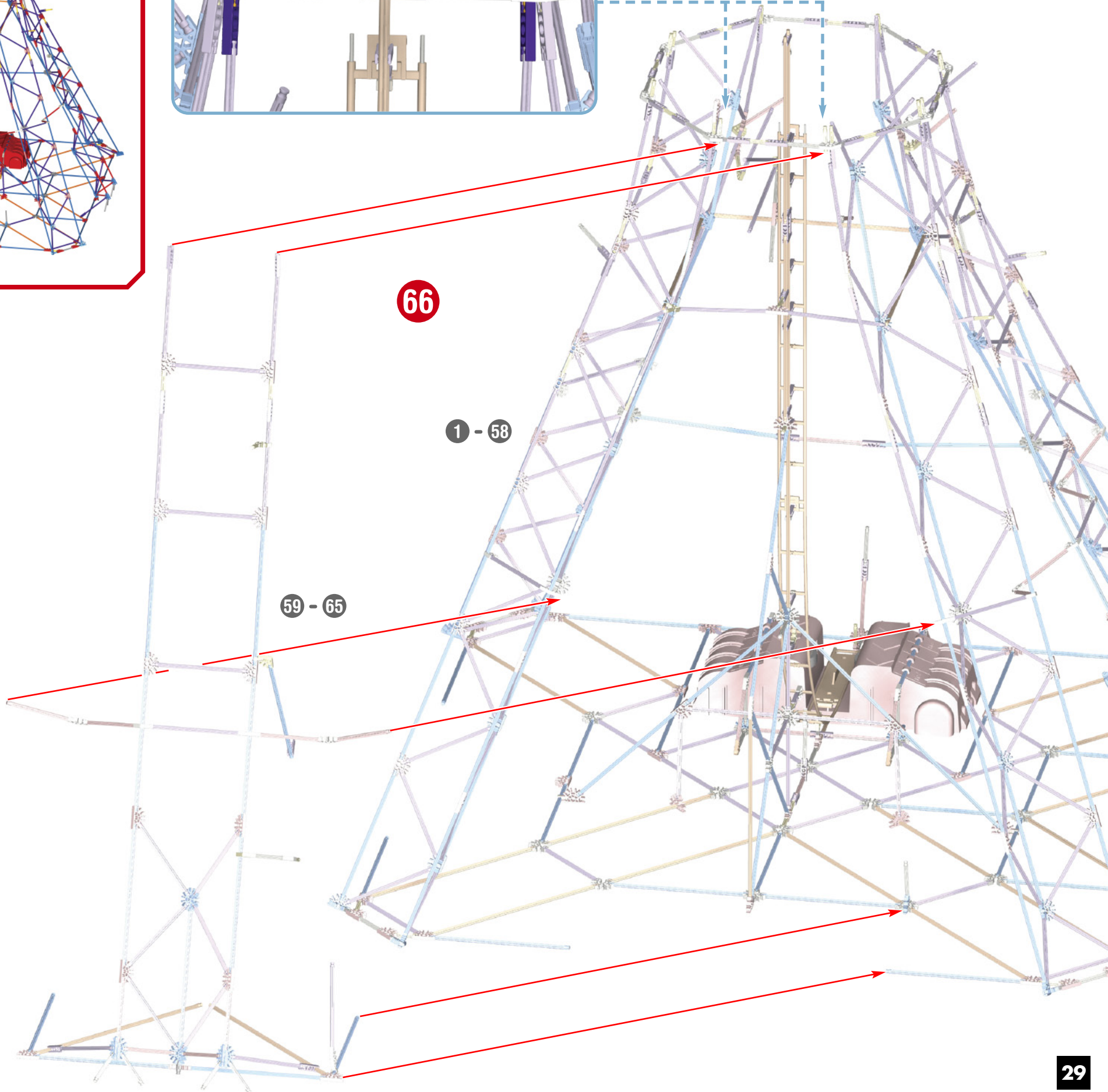
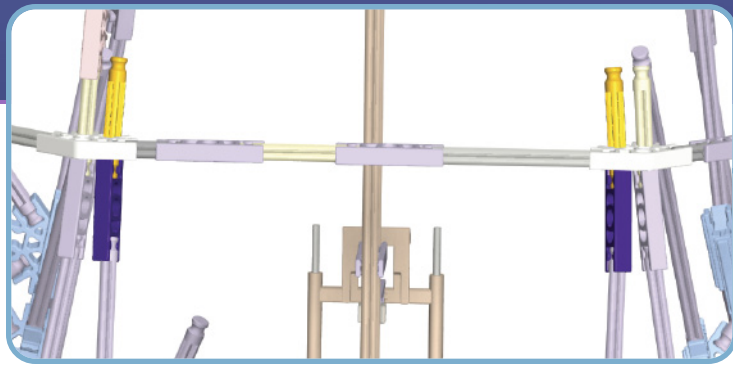

66

1 - 58

59 - 65

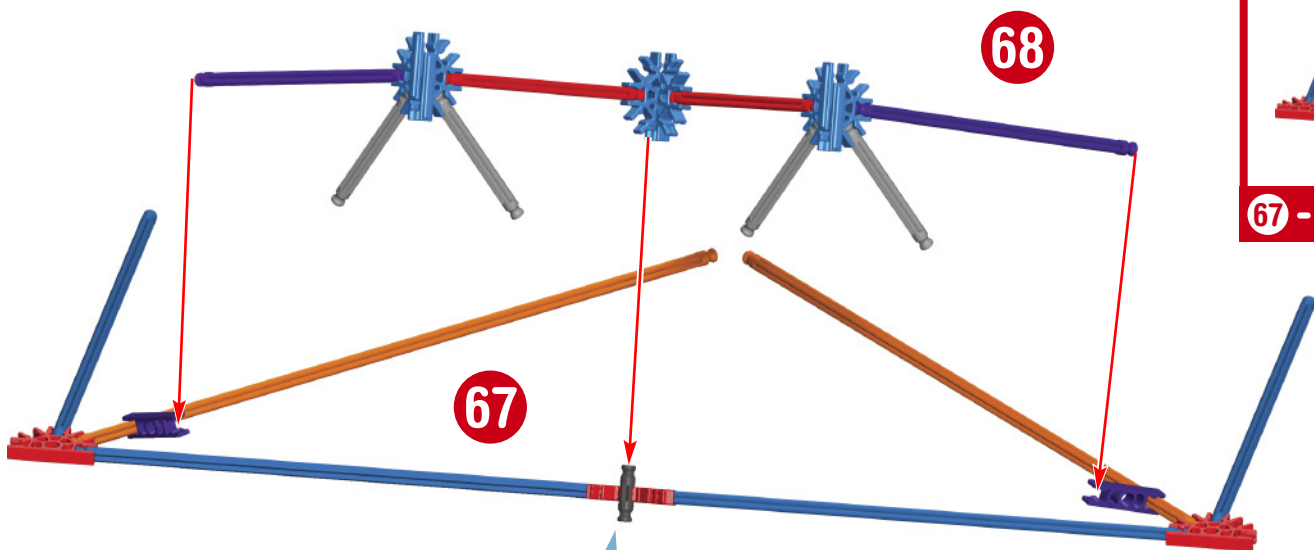

67

68

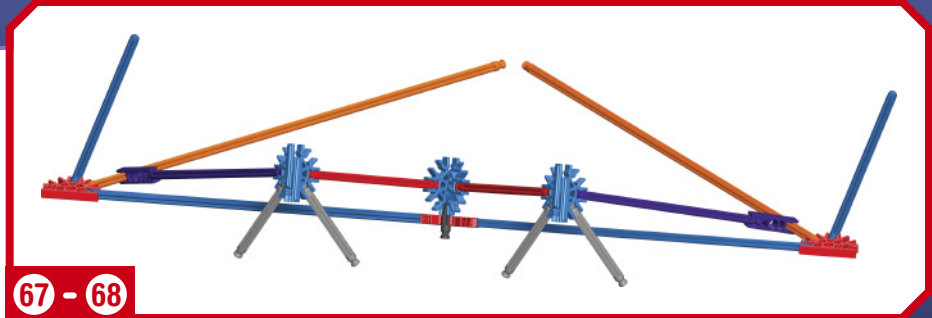

67 - 68

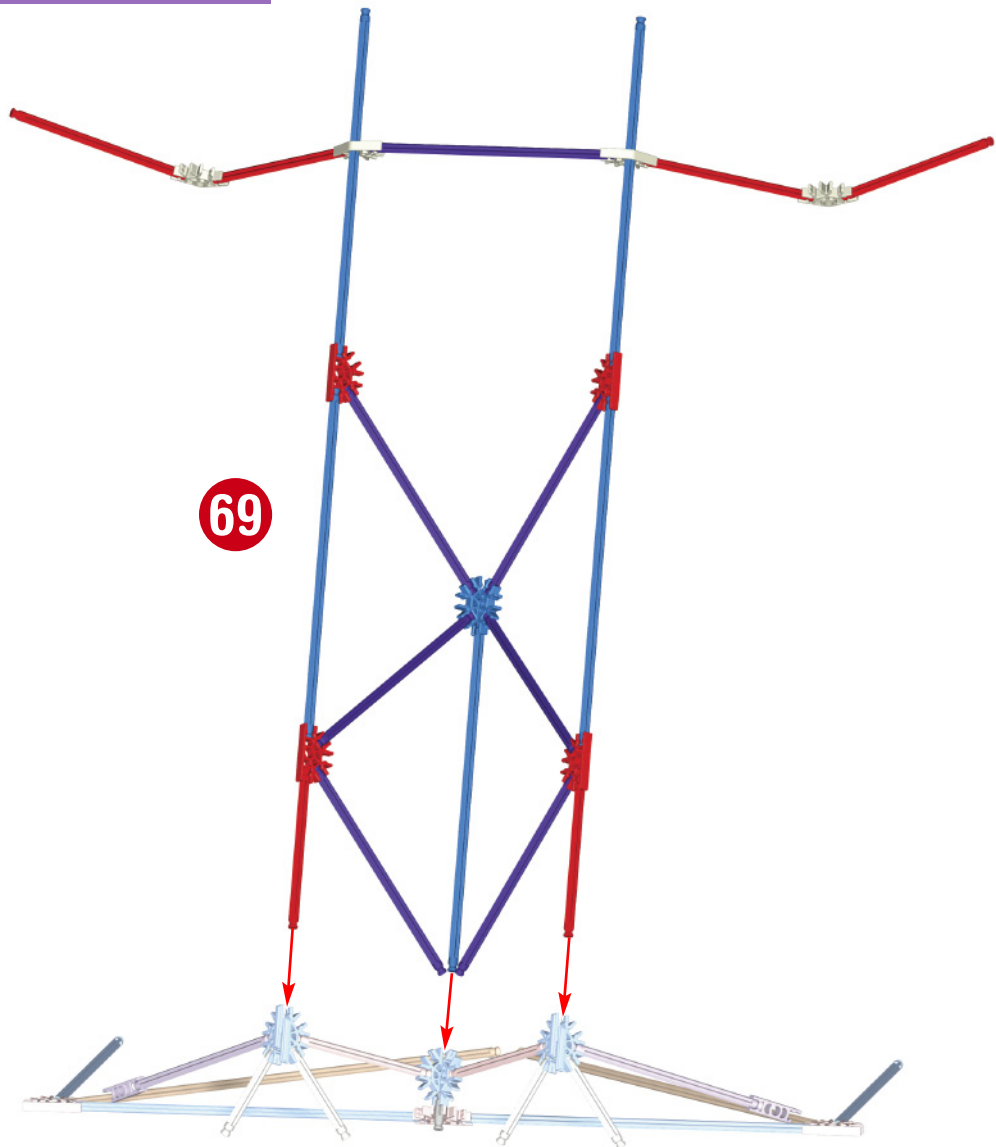
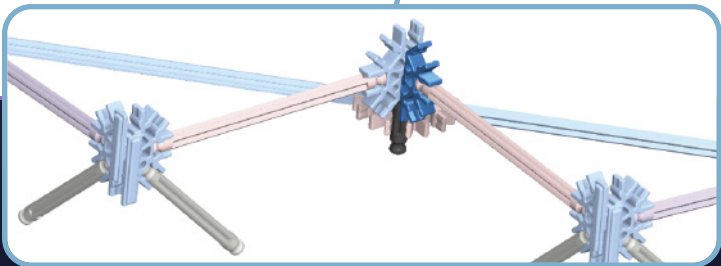

69

67 - 68

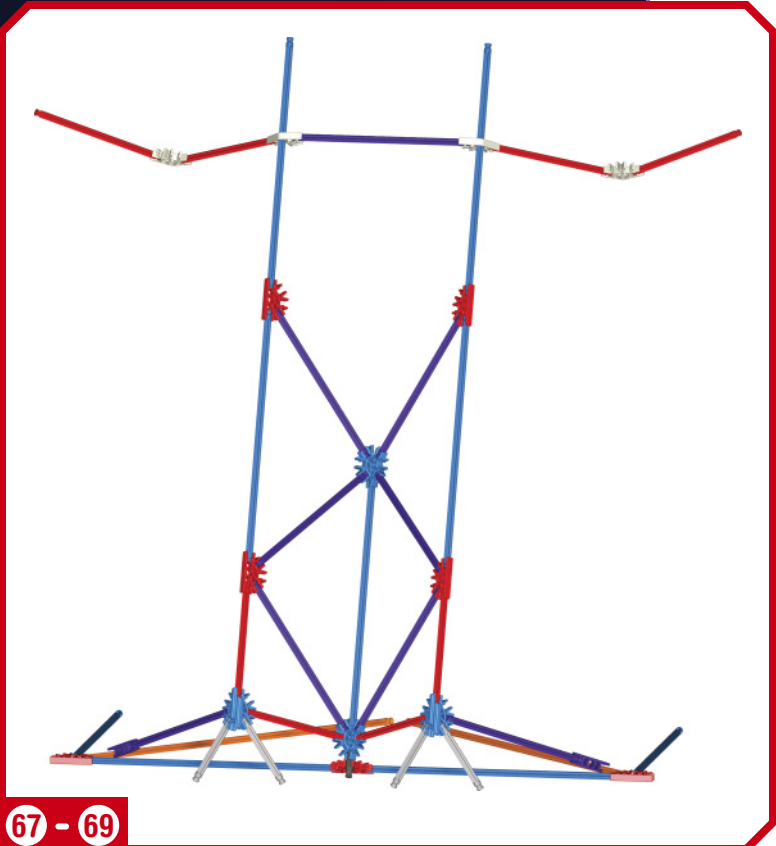

67 - 69

70

72

71

67 - 69

67 - 70

67 - 72

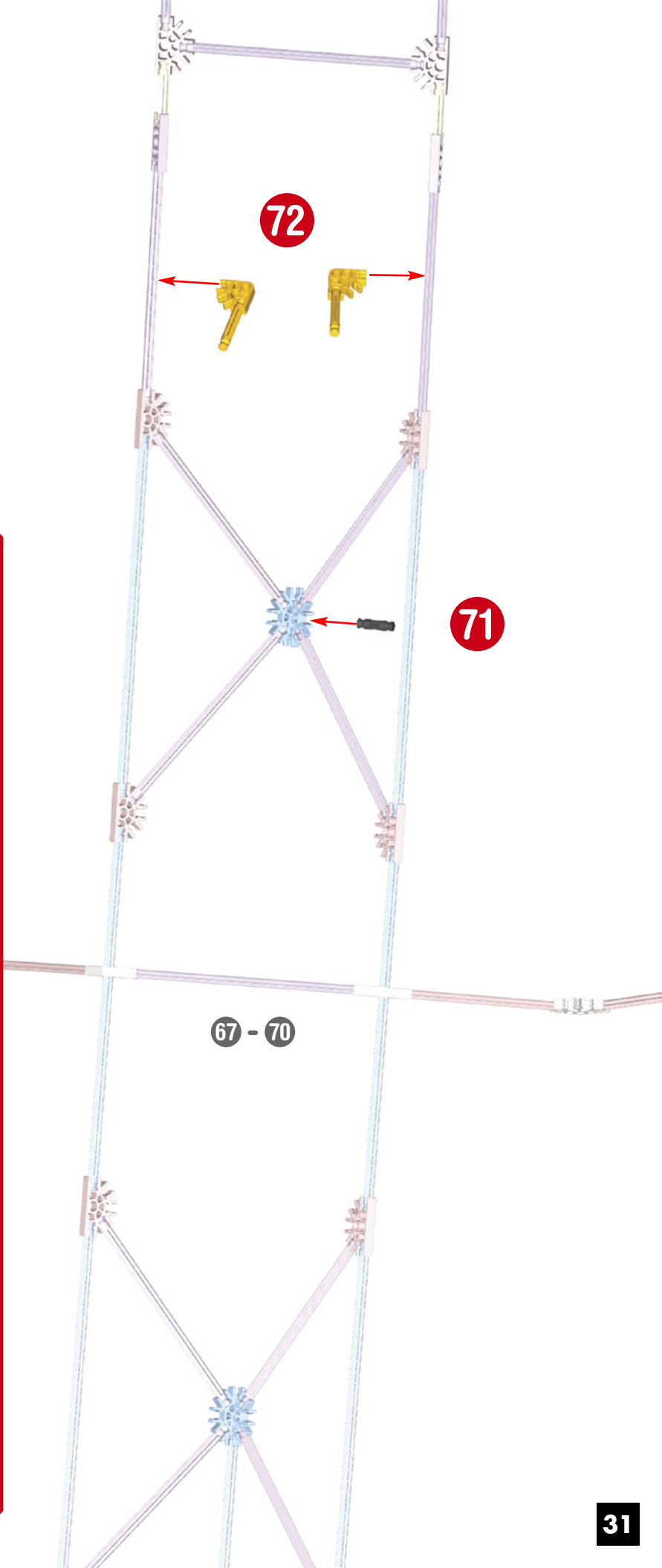
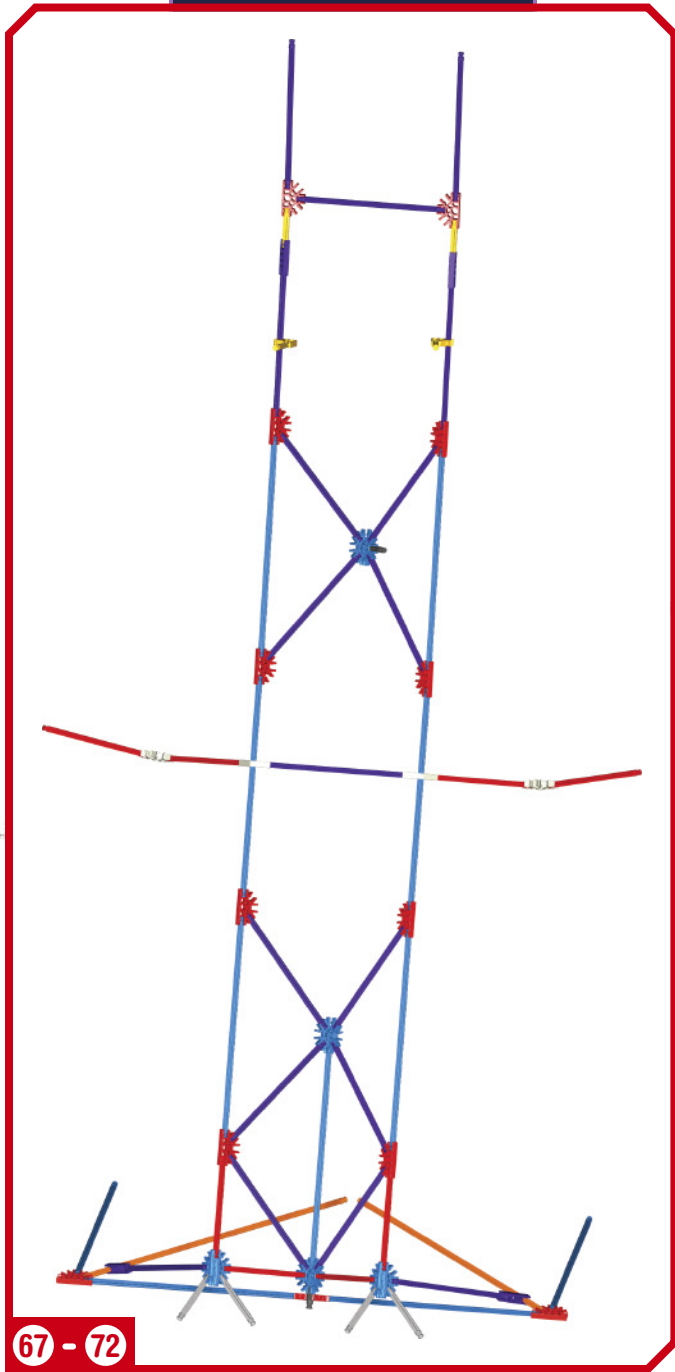
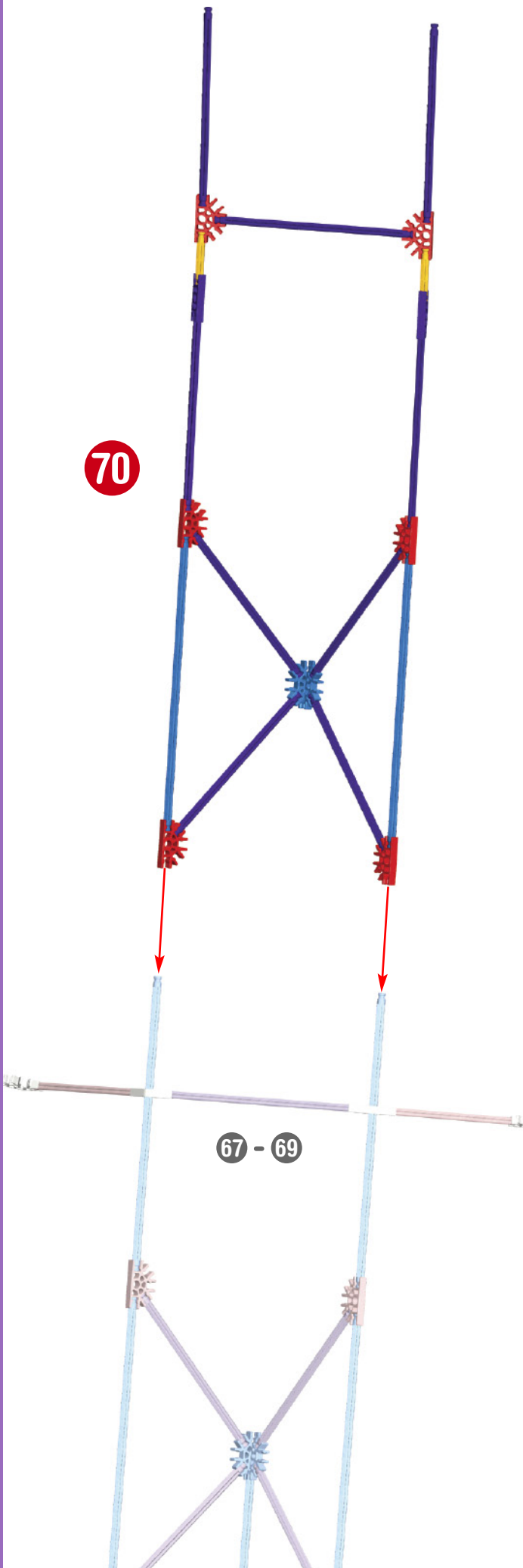

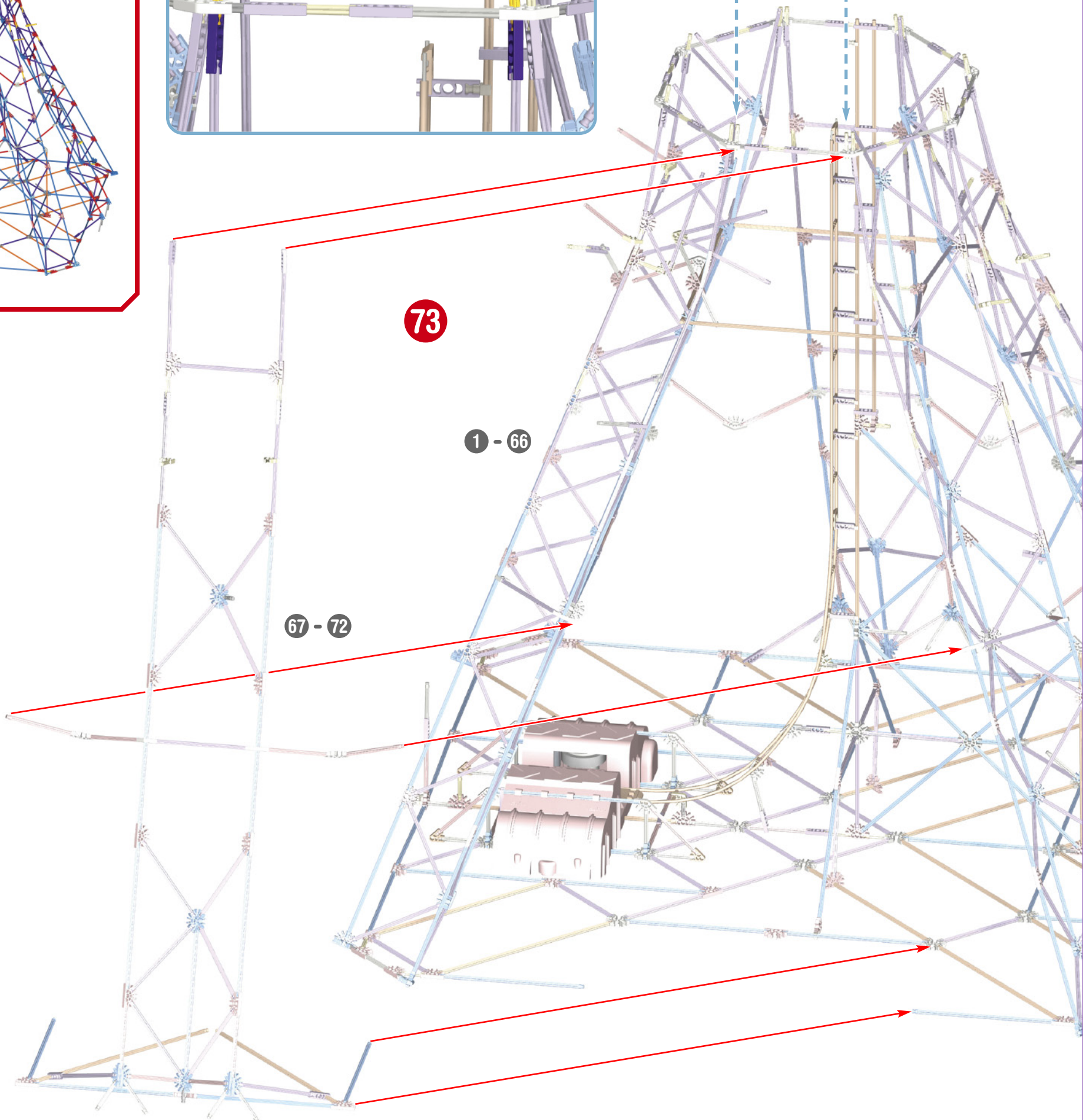
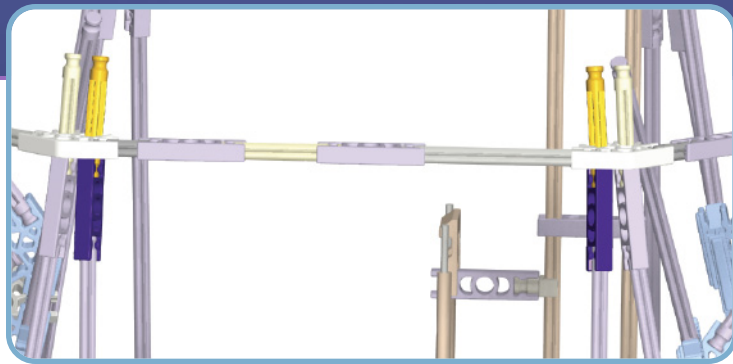
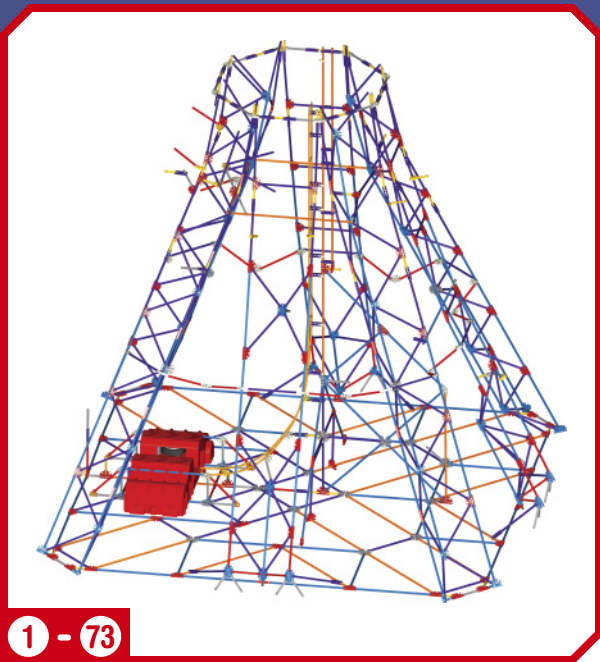

x4

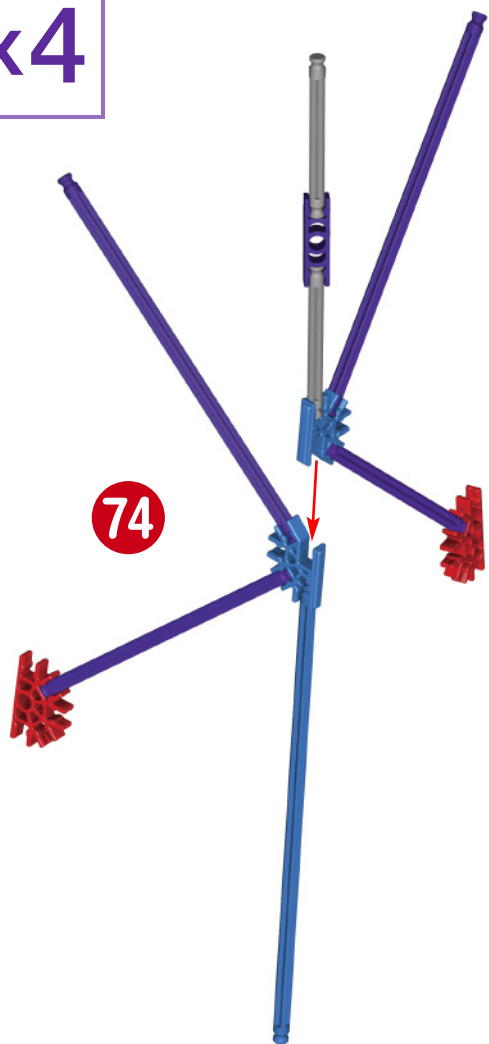

x4

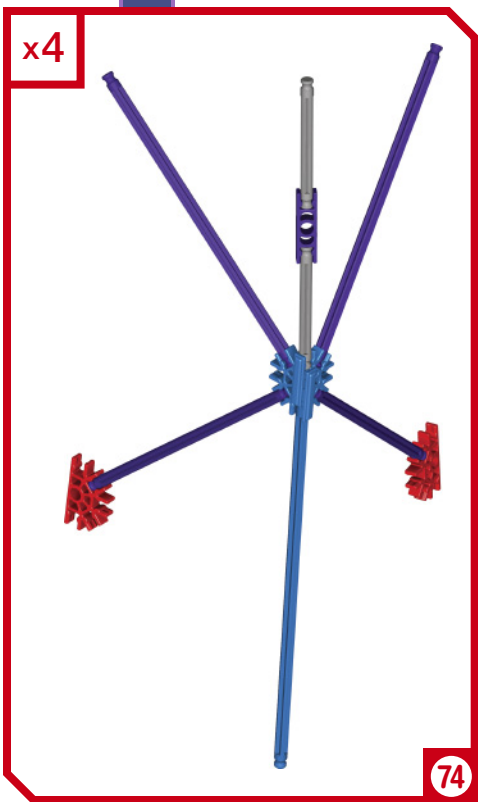

75

74

74

76

1 - 73

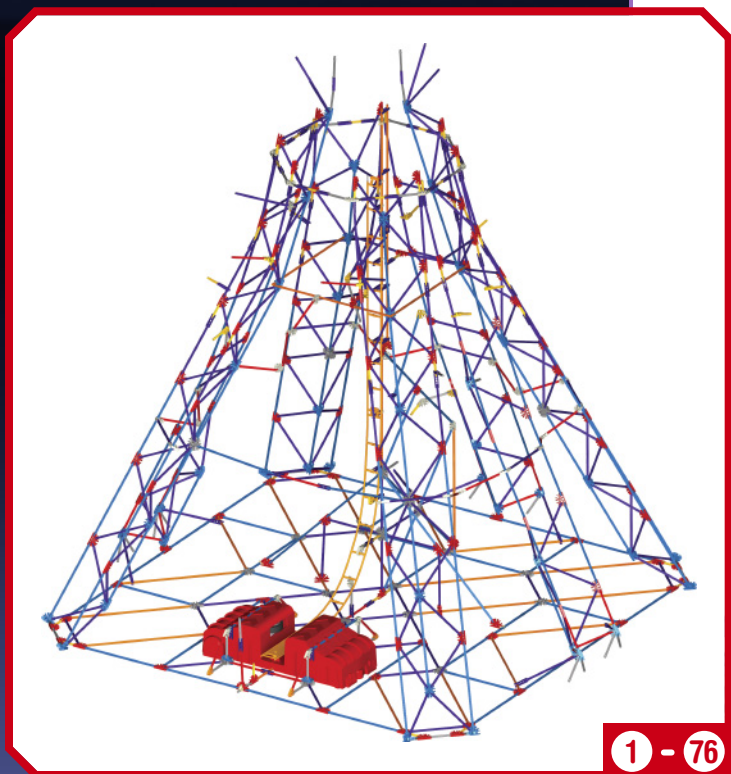

1 - 76

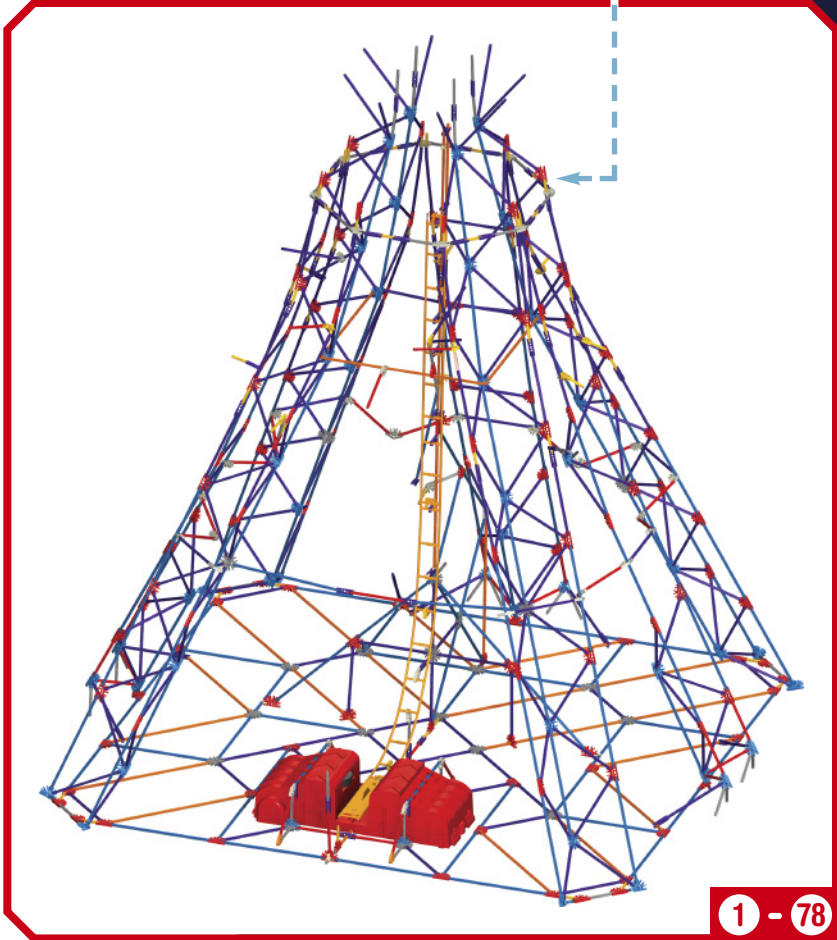
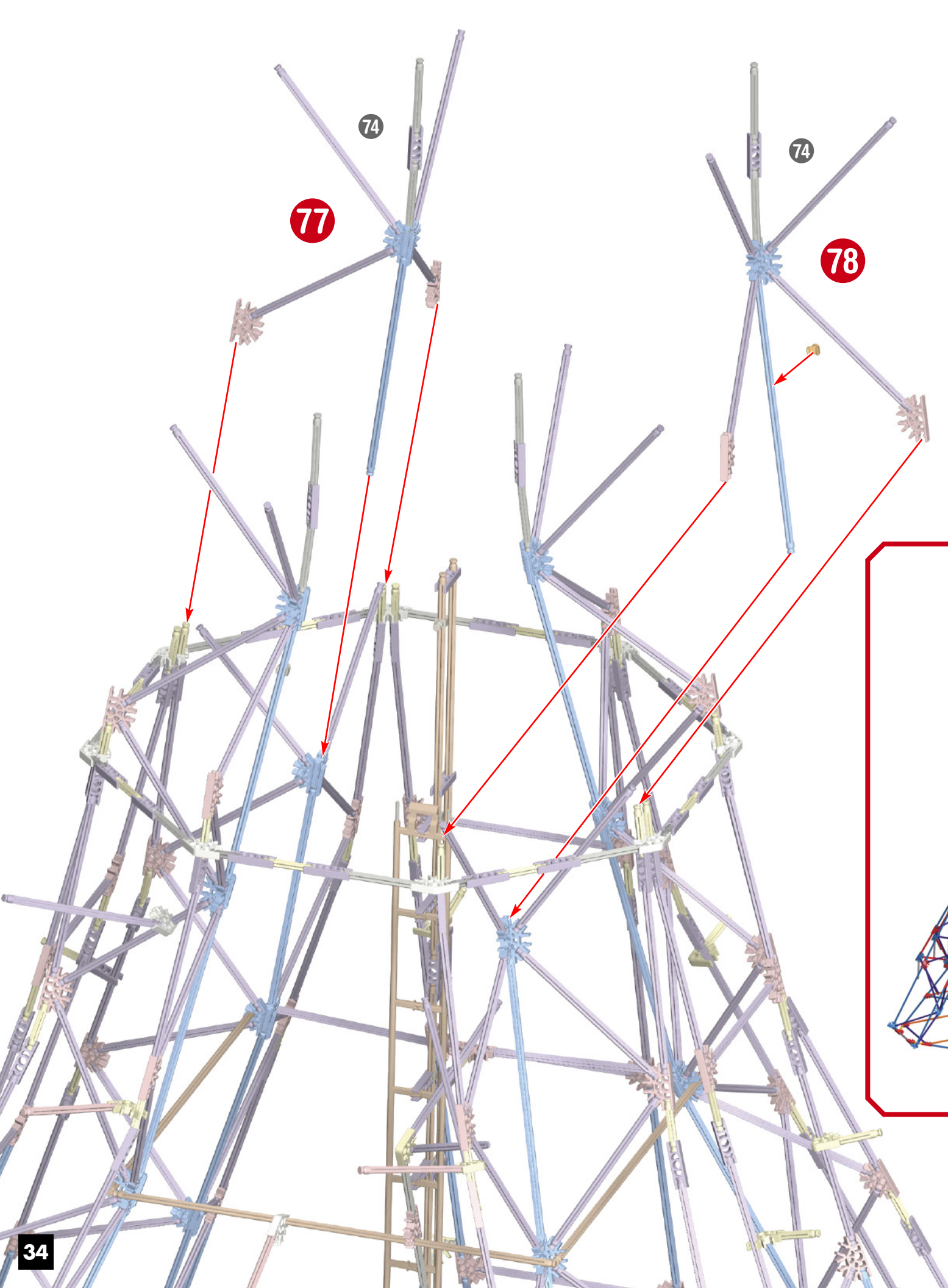

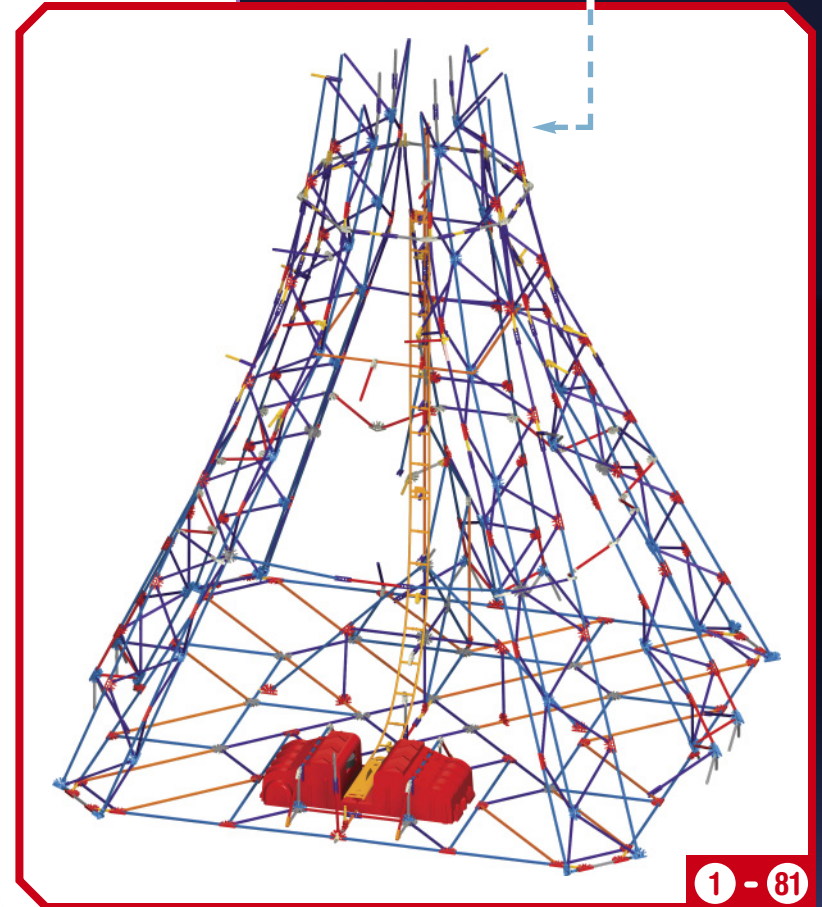
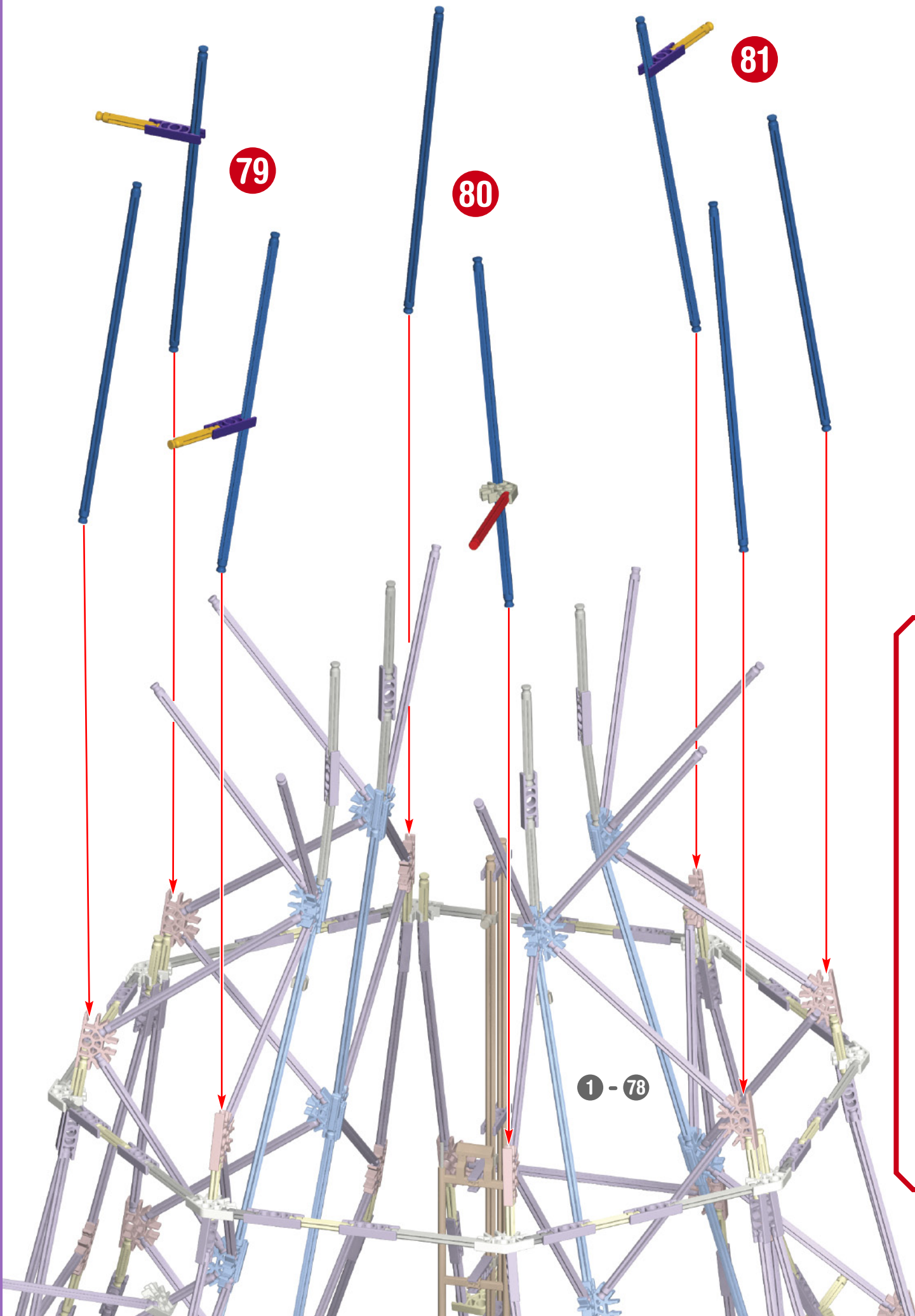

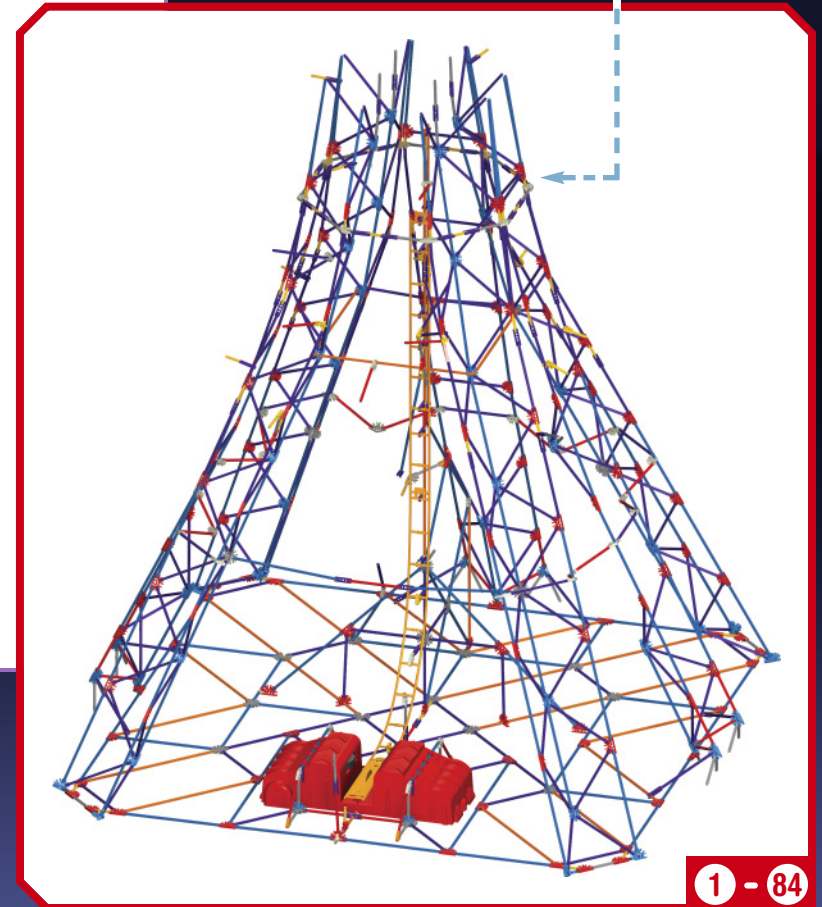
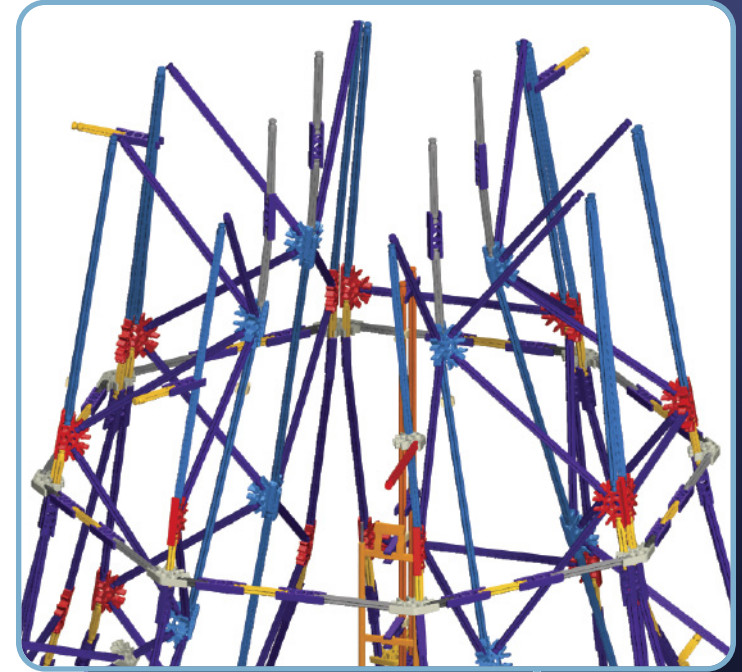
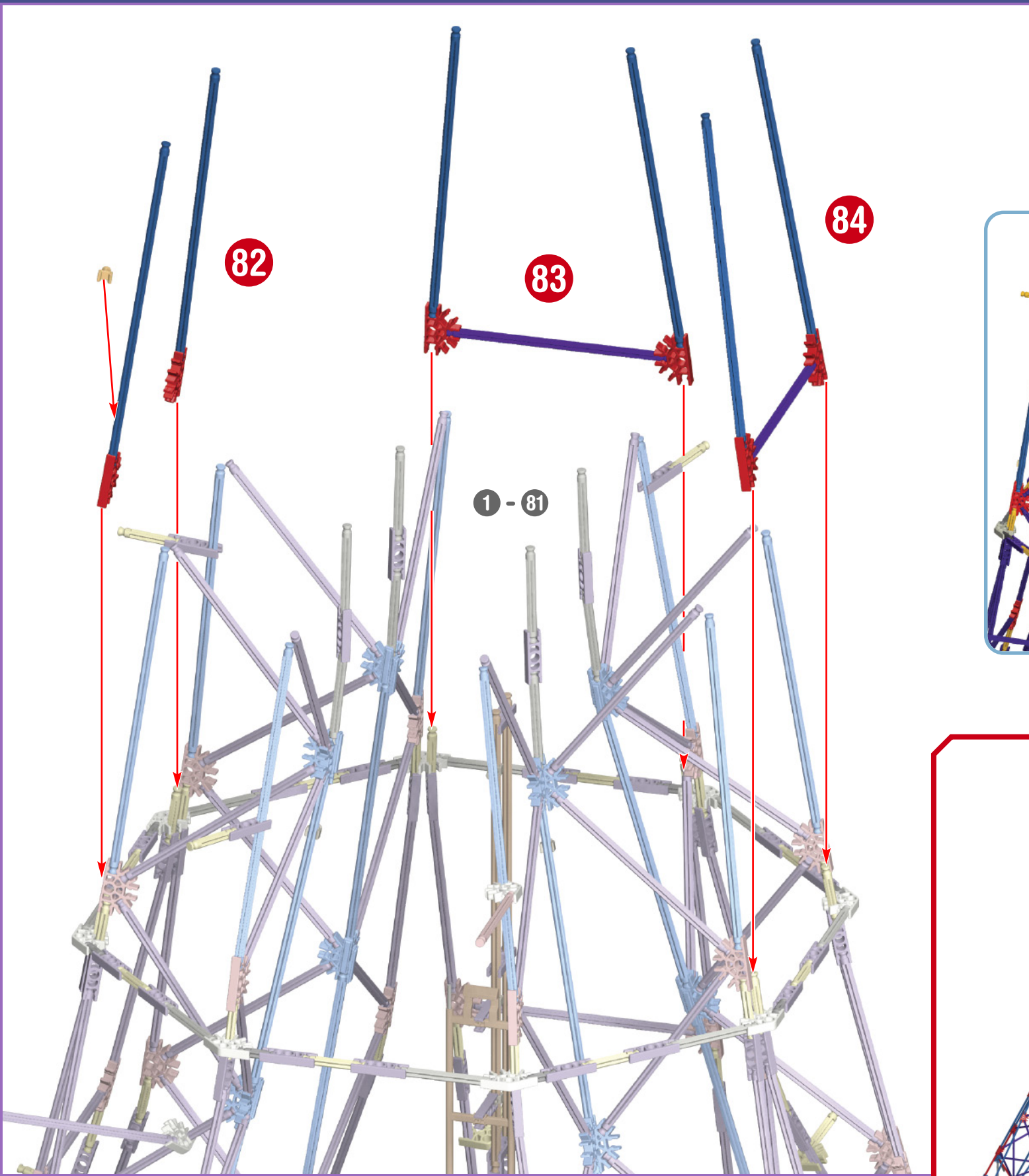

Always join this end of the track to the previous track piece first, then connect the rest of the track to the tower.

- (FR) Connecte toujours le côté supérieur du circuit contre le côté supérieur tout au long de la construction.
- (ES) Al construir, conecta siempre la pista de lado superior a lado superior.
- (DE) Die einzelnen Schienenstücke müssen immer mit der Oberseite nach oben zeigen, wenn sie miteinander verbunden werden.
- (IT) Collega sempre la rotaia parte superiore a parte superiore in tutta la costruzione.
- (PT) Liga sempre a face superior da pista à face superior durante a montagem.
- (NL) Maak steeds de bovenkant van het spoor vast aan de bovenkant tijdens de opbouw.



It comes in two different shapes.

- (FR) Il est fait dans deux différents styles.
- (ES) Esto viene a dos estilos diferentes.
- (DE) Es kommt in zwei verschiedenen Stilen.
- (IT) Si è fatto in due forme diverse.
- (PT) É feito em duas formas diferentes.
- (NL) Het is gemaakt in twee verschillende vormen.

85

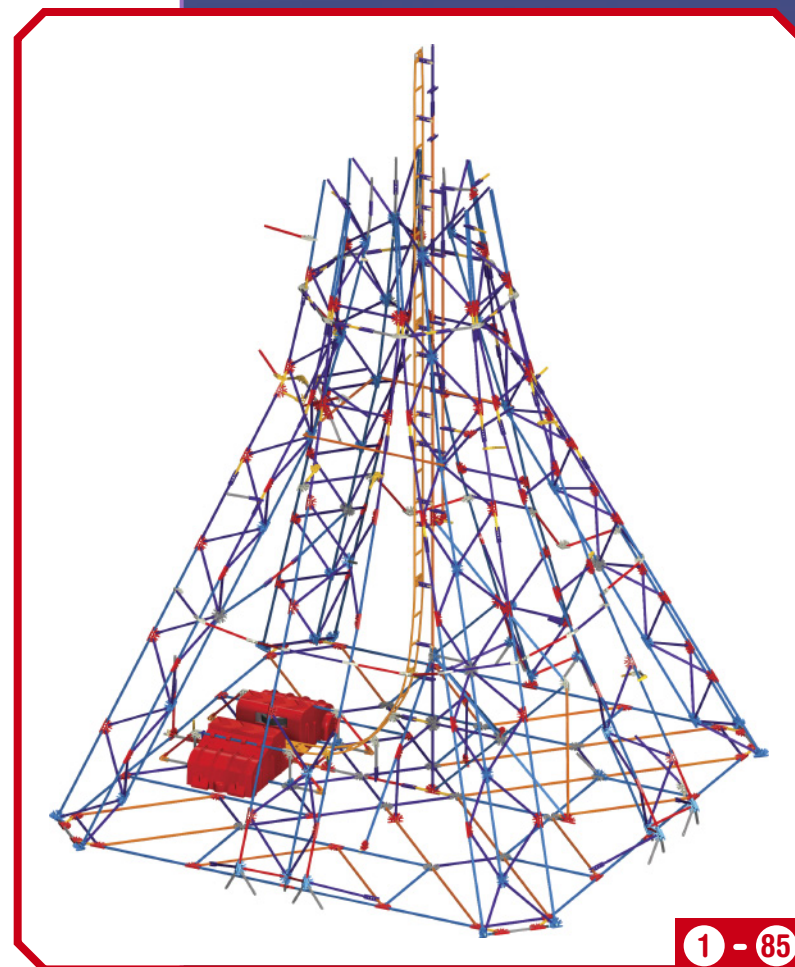
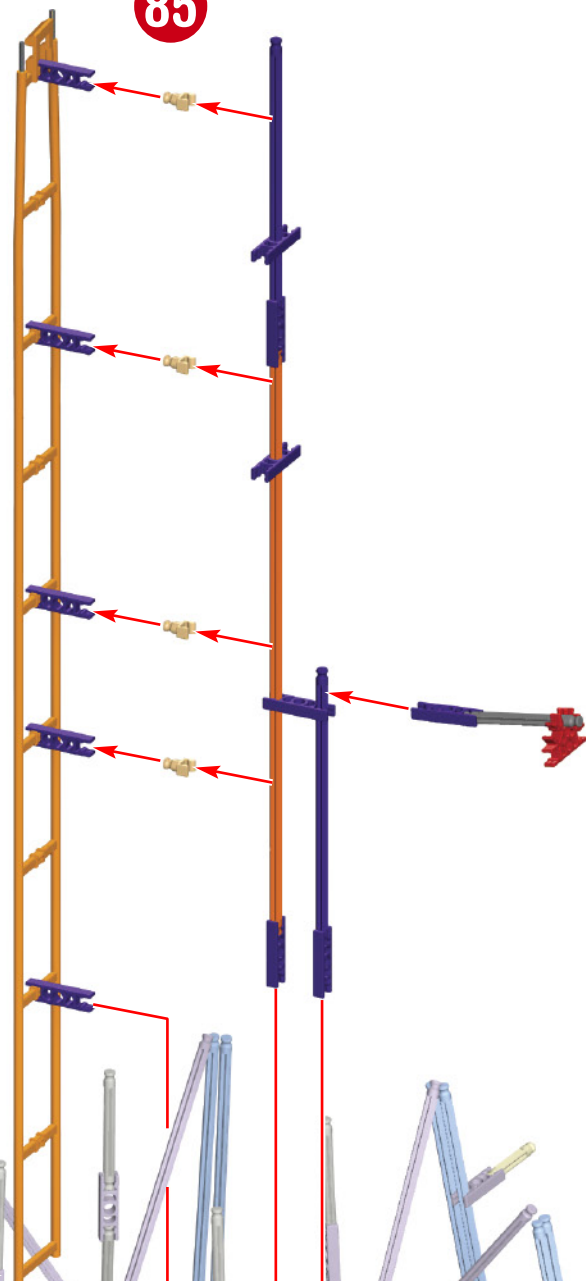

1 - 85

1 - 84

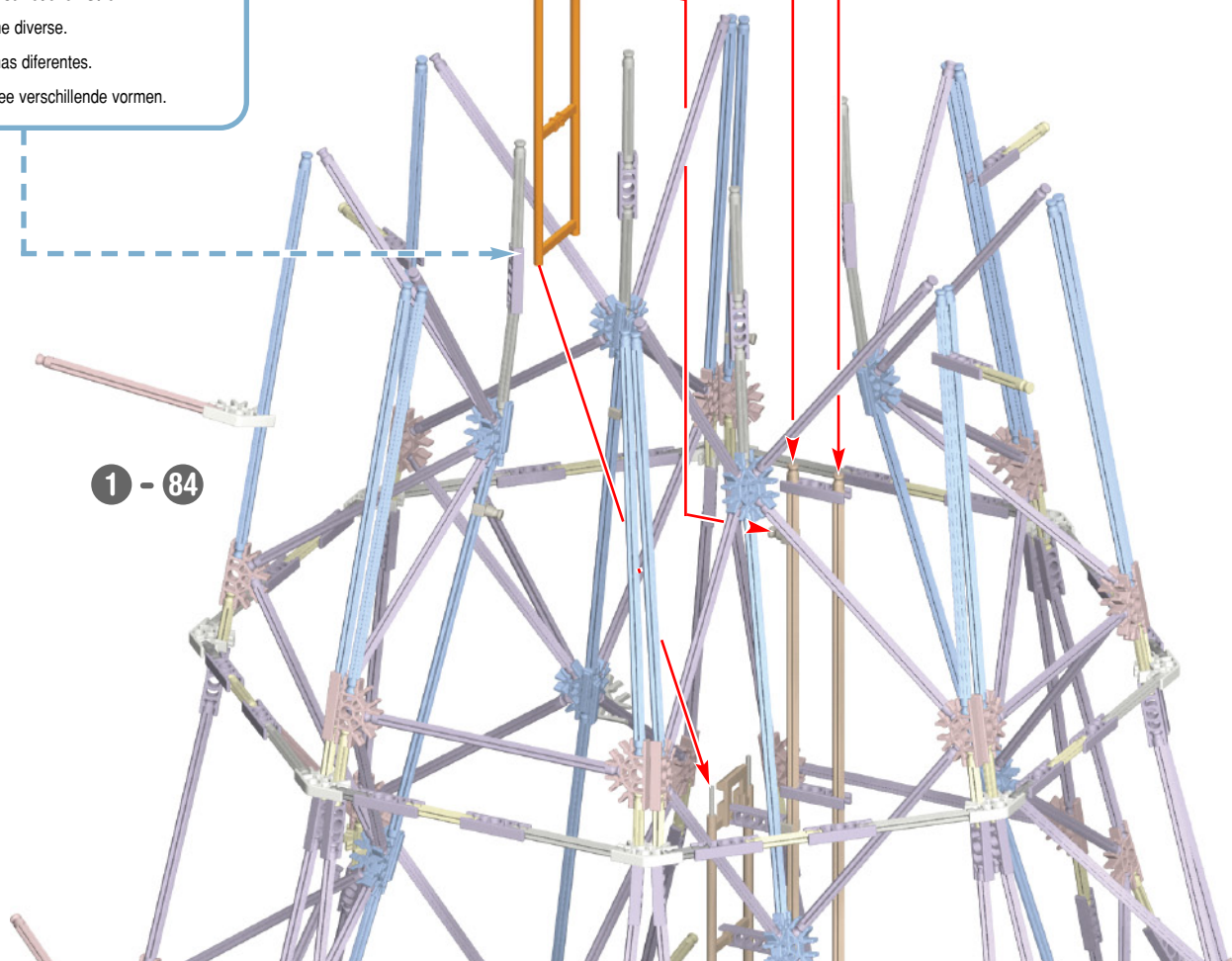

87

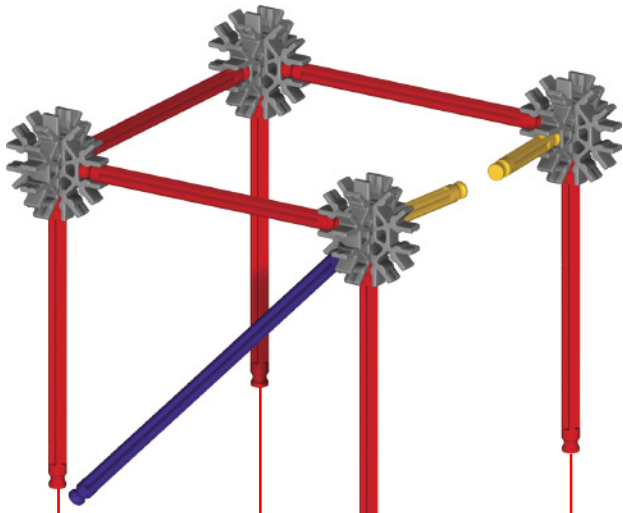

86

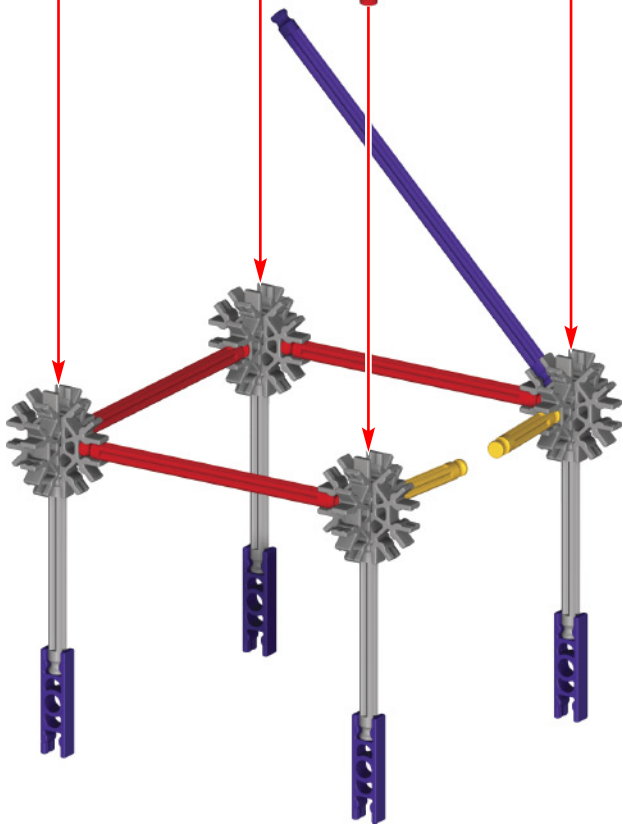

88

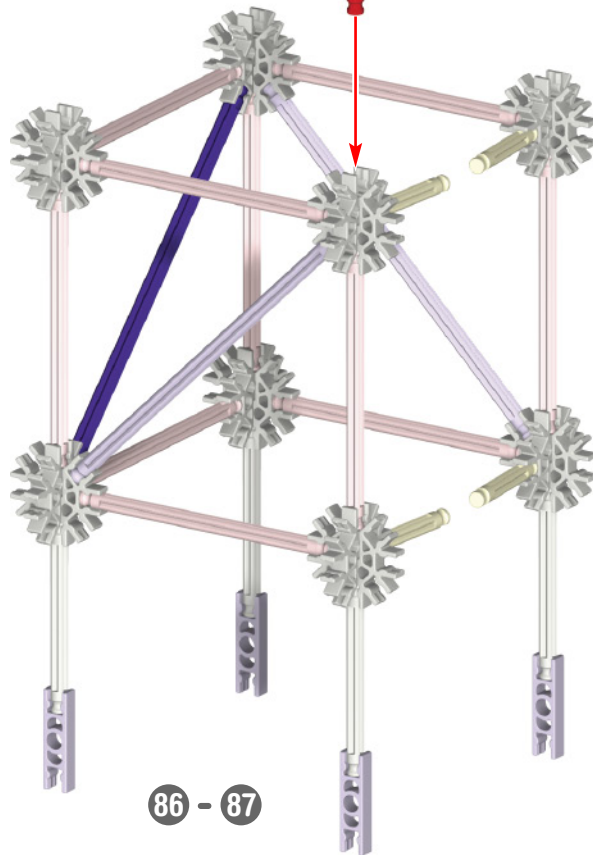

86 - 87

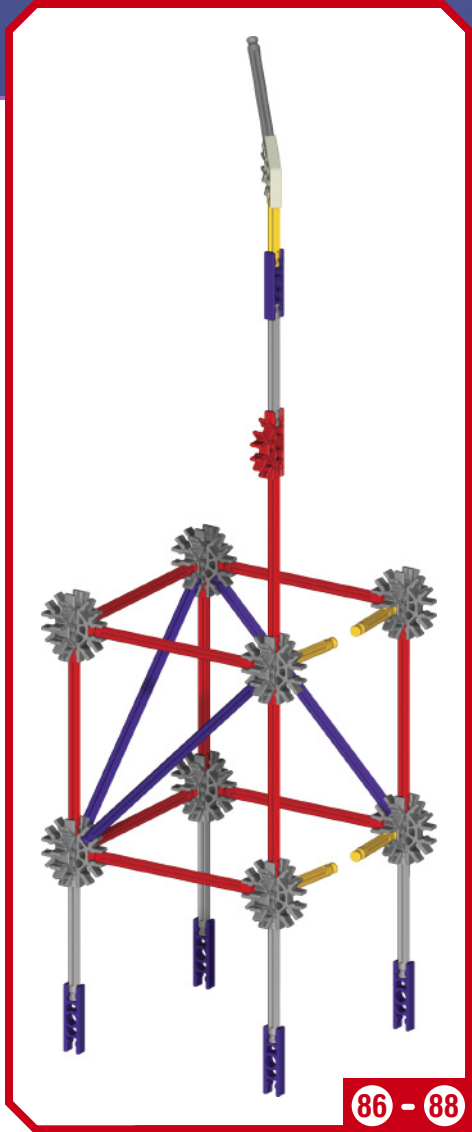

86 - 88

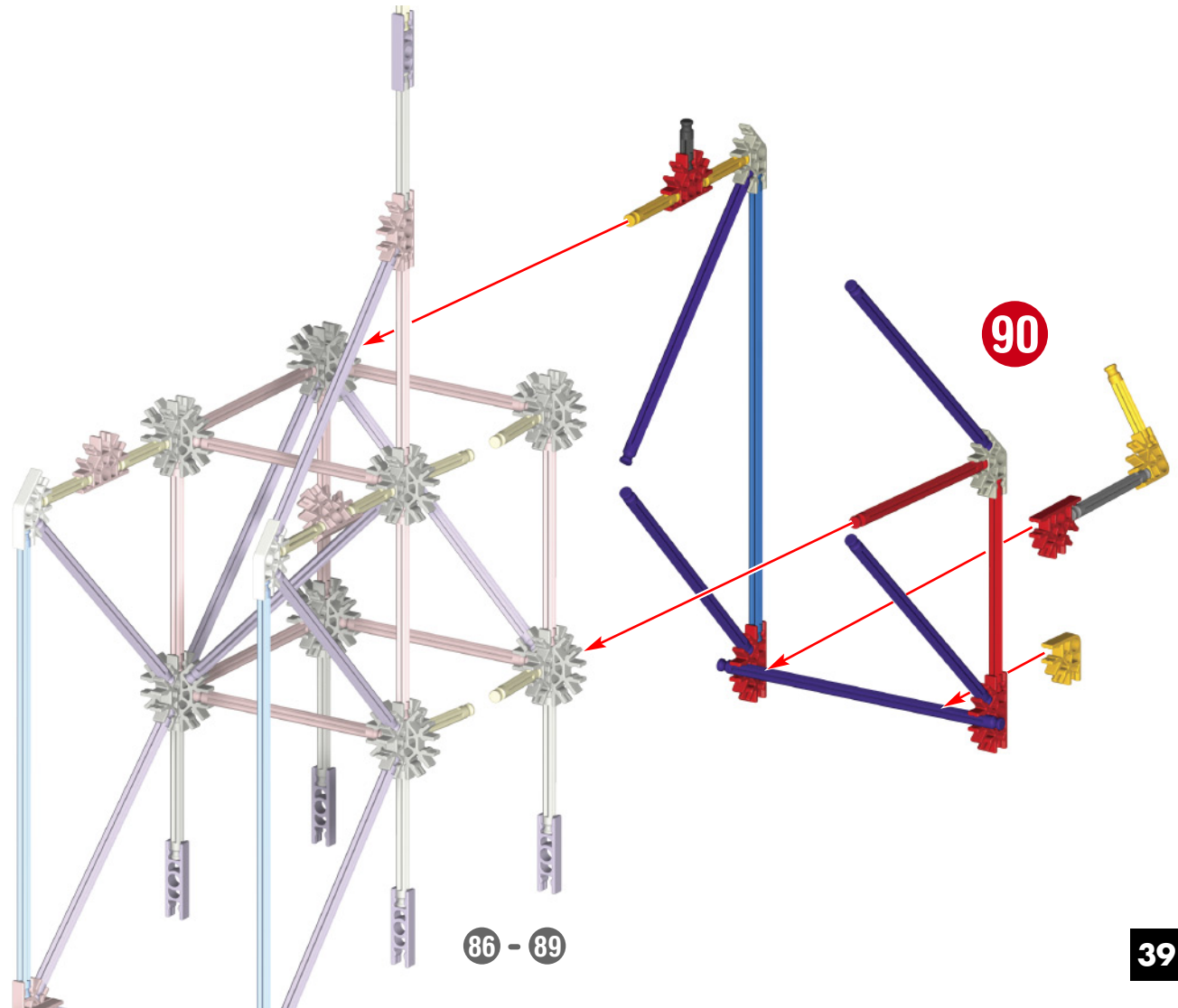
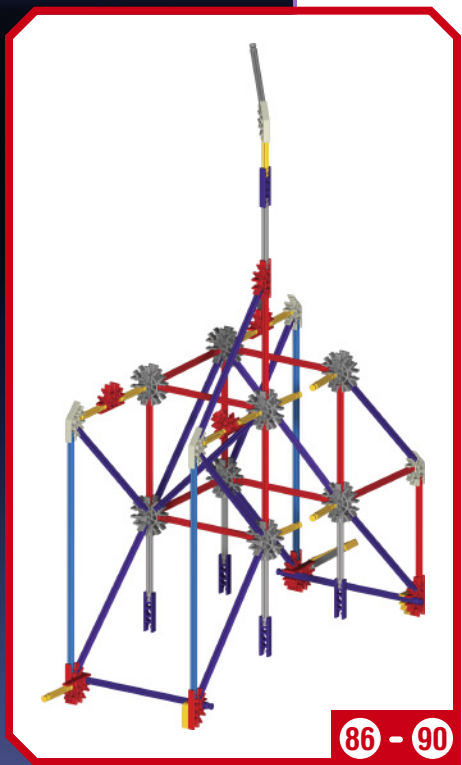
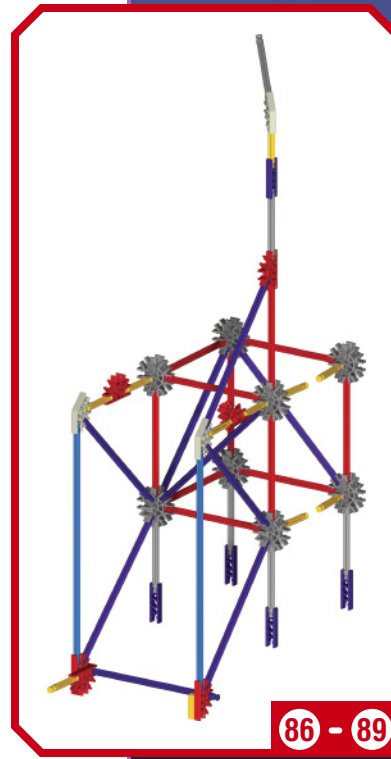
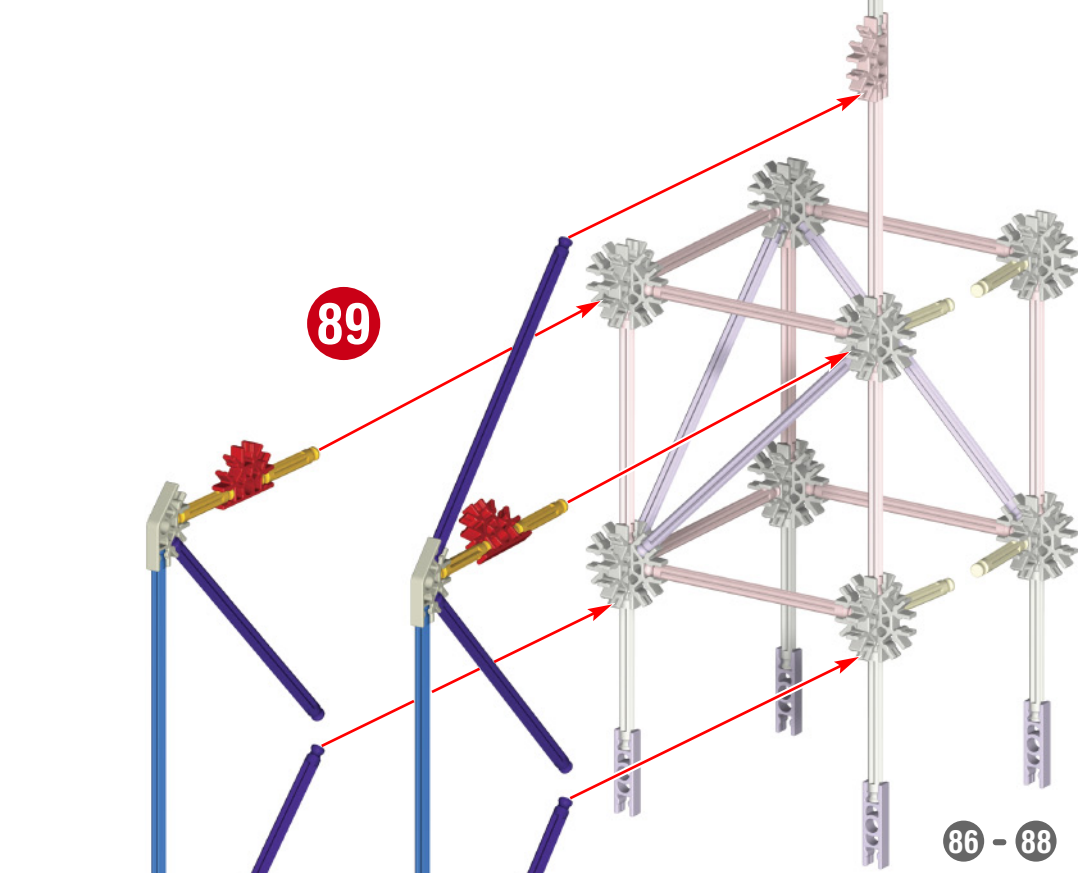

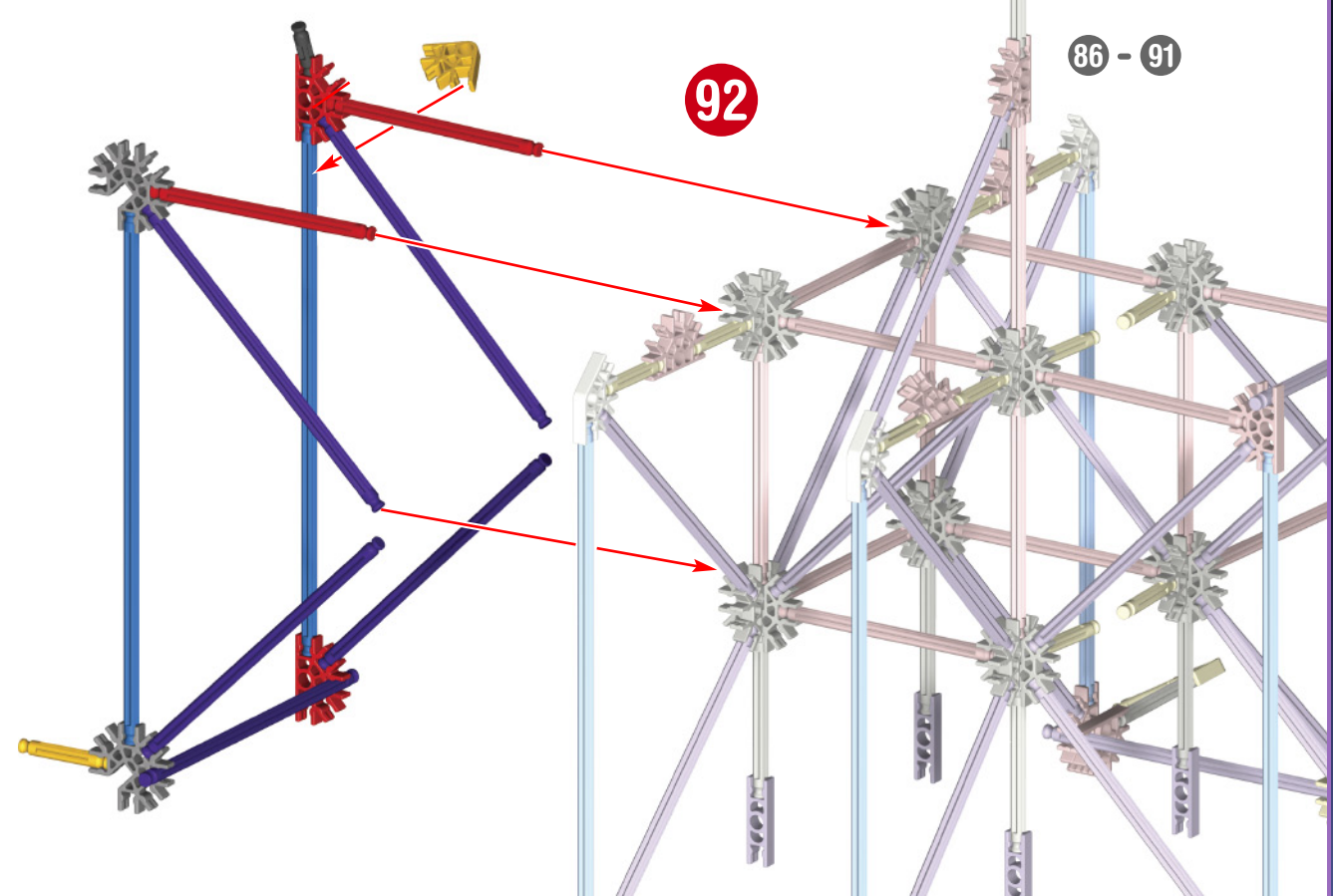
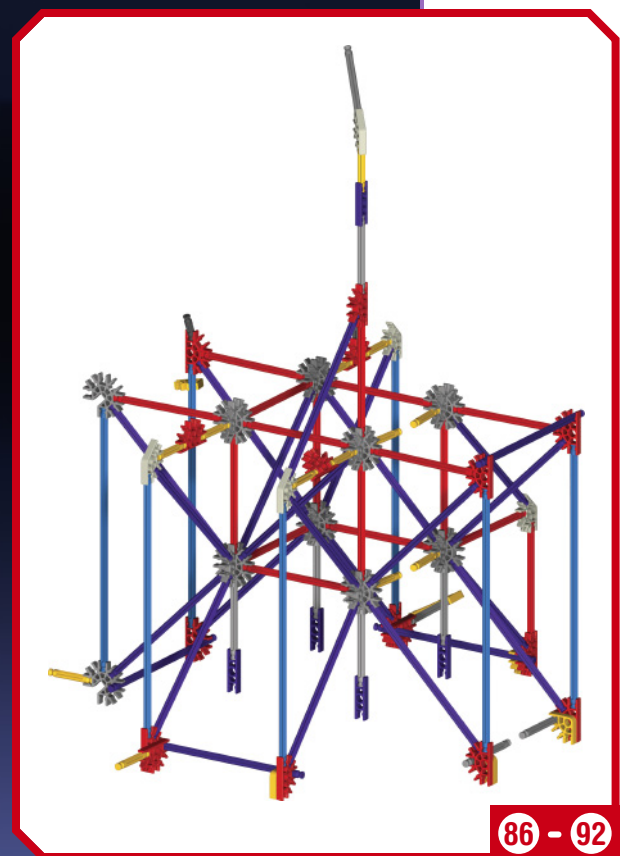
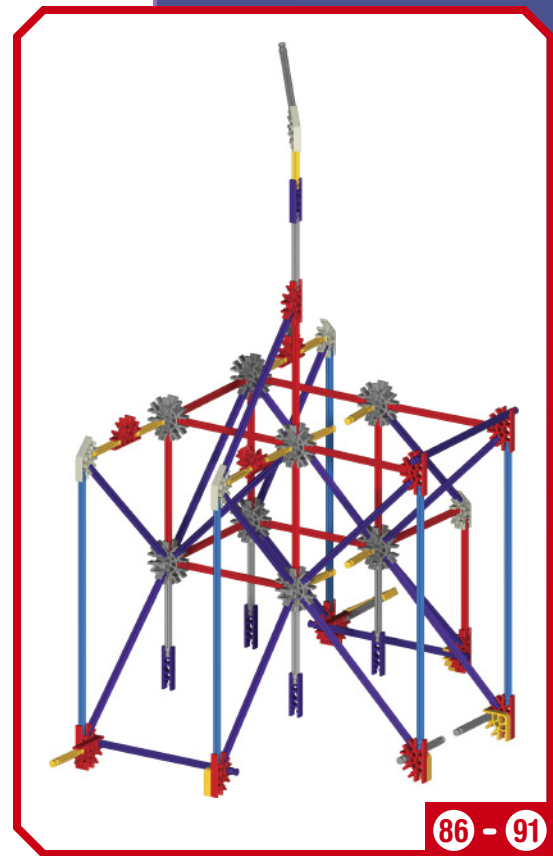
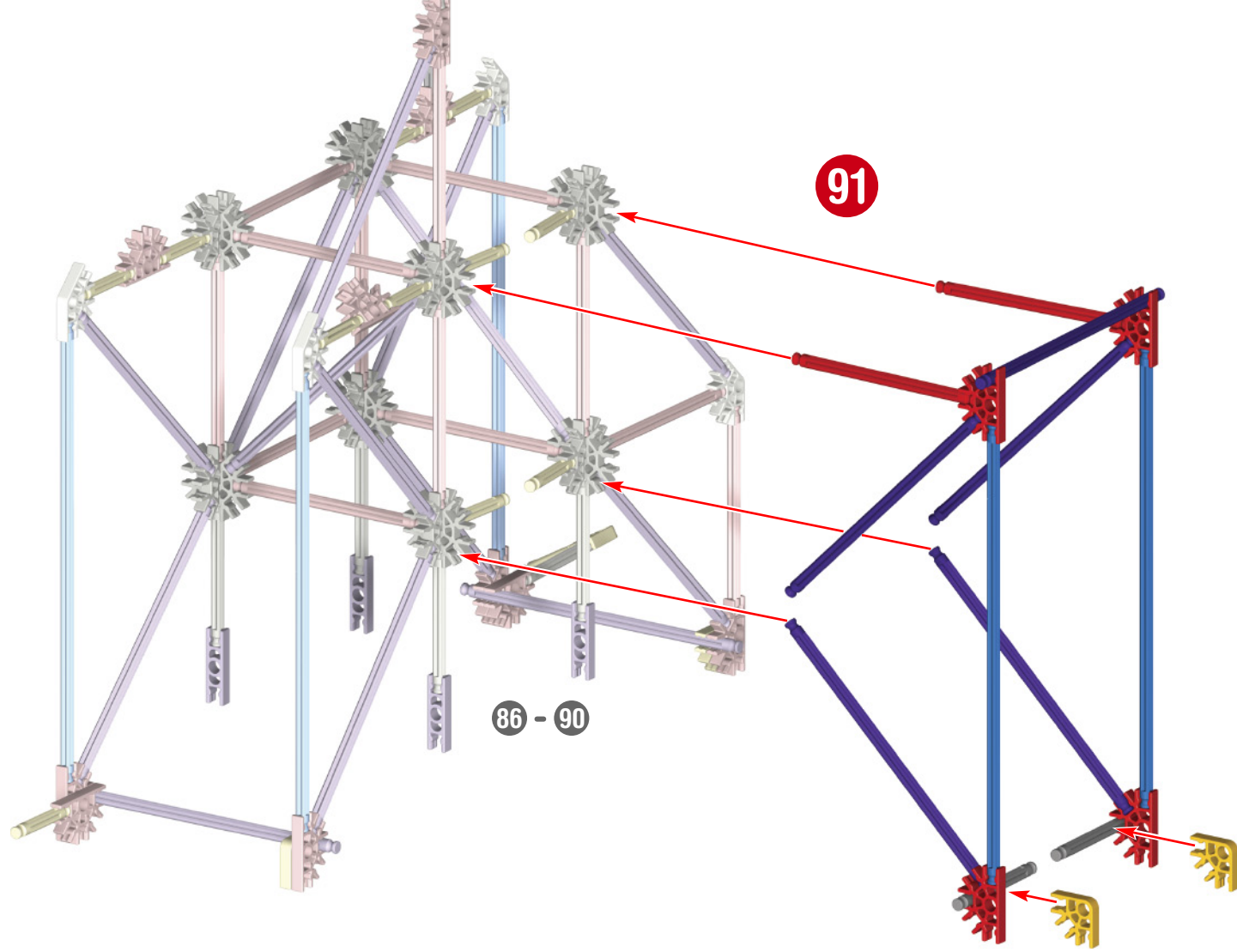

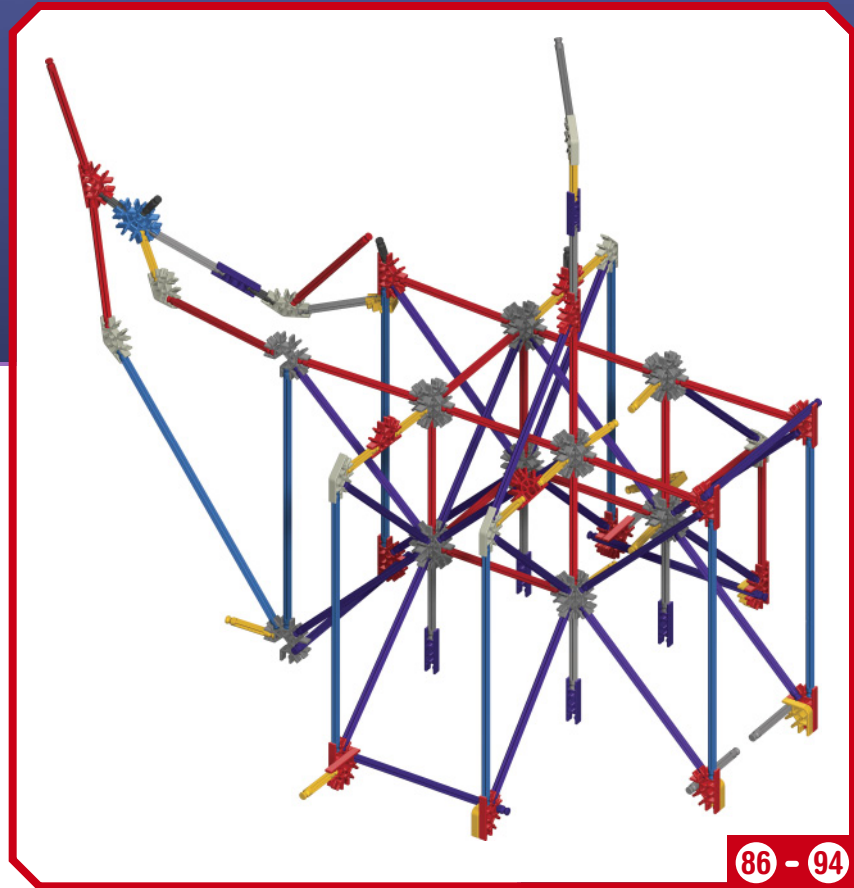
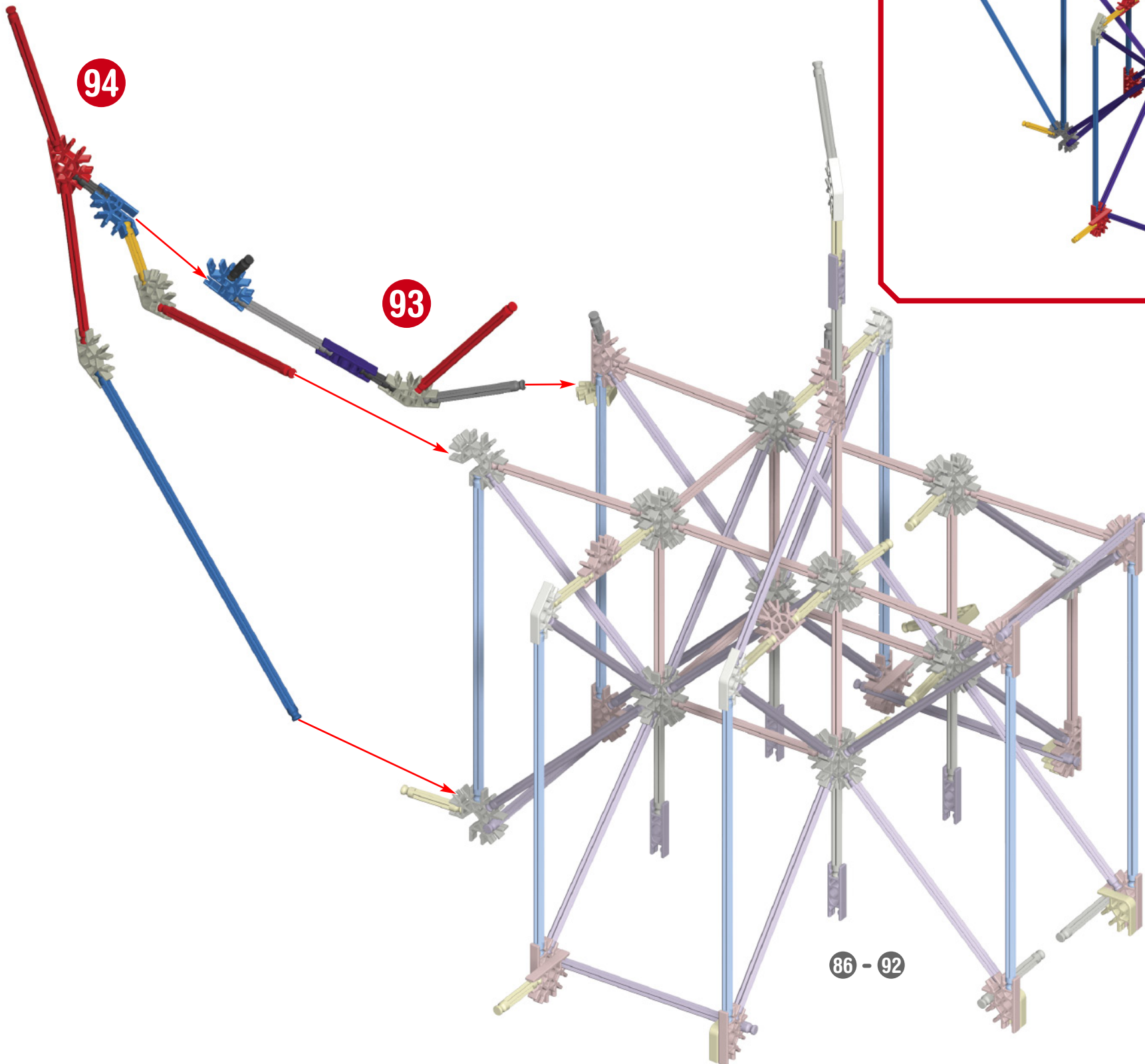

86 - 94

86 - 92

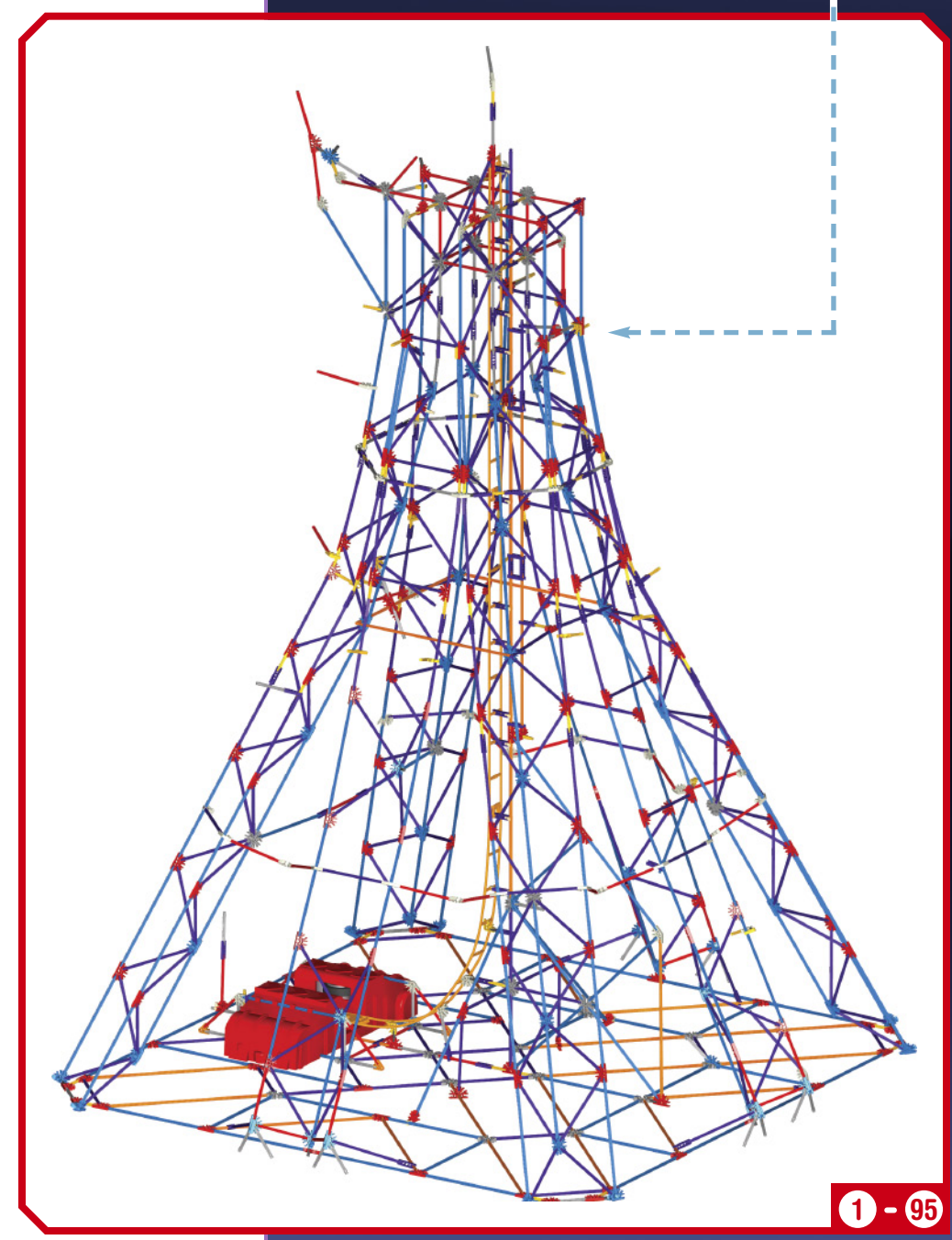
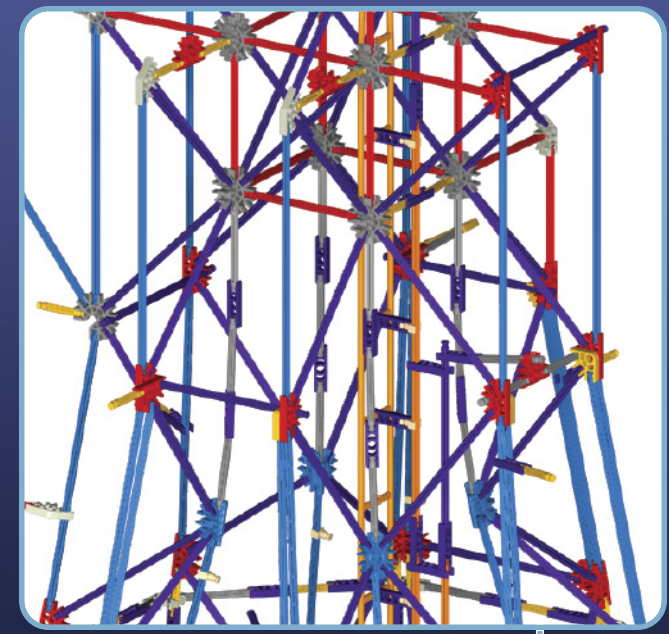
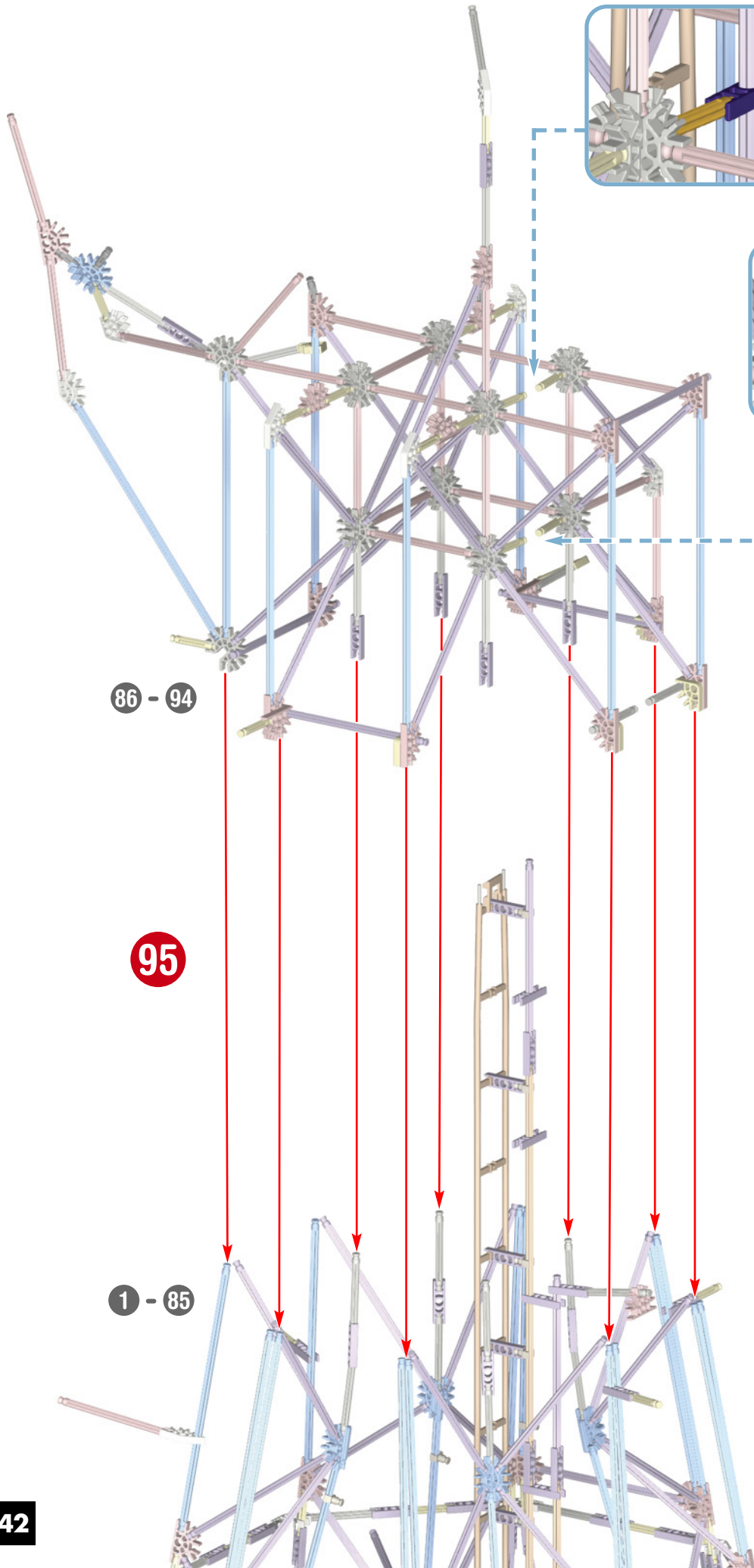

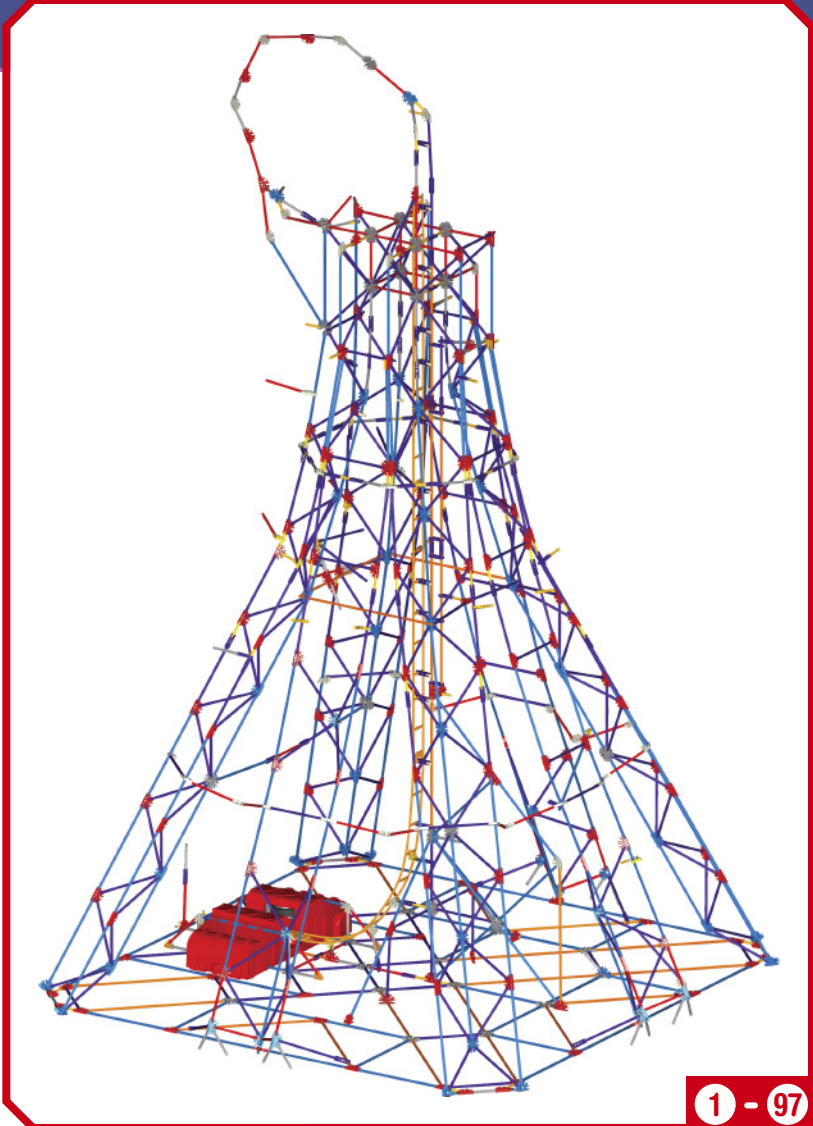
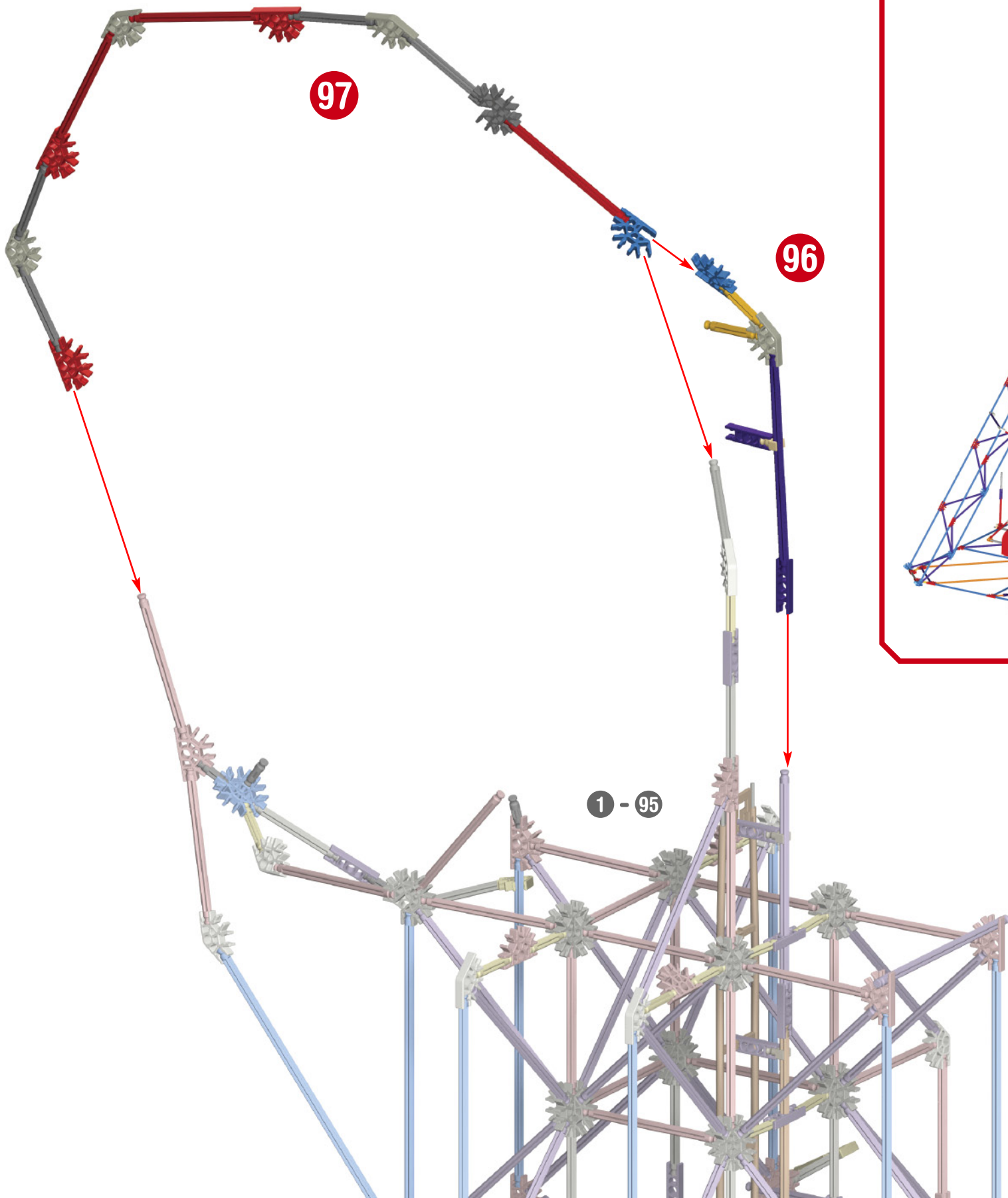

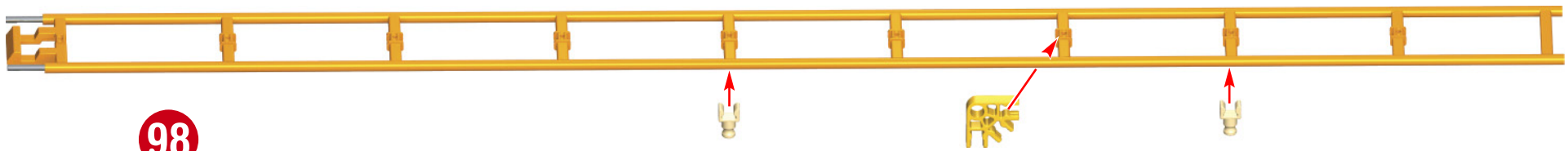

98

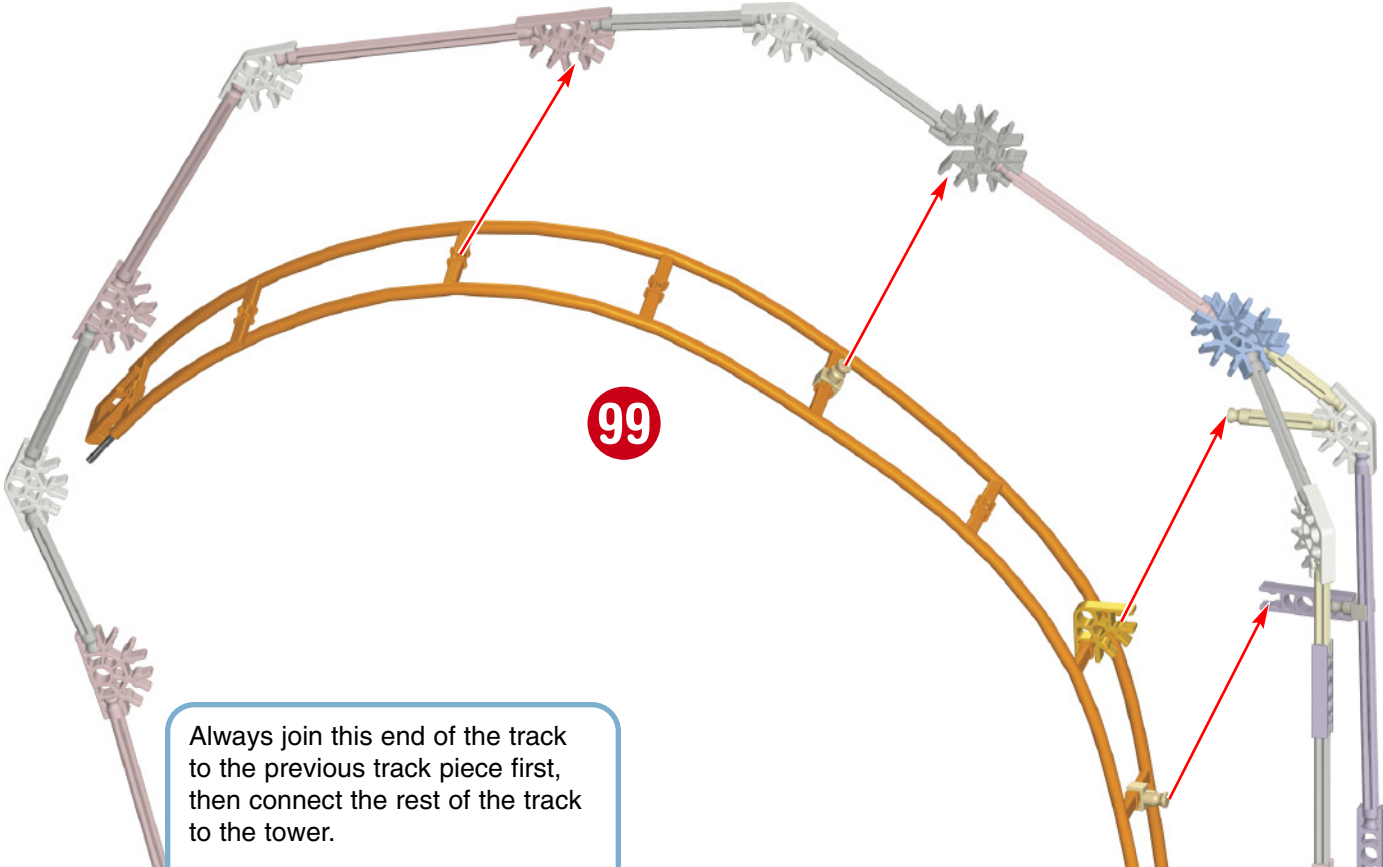

99

Always join this end of the track to the previous track piece first, then connect the rest of the track to the tower.

- (FR) Connecte toujours le côté supérieur du circuit contre le côté supérieur tout au long de la construction.
- (ES) Al construir, conecta siempre la pista de lado superior a lado superior.
- (DE) Die einzelnen Schienenstücke müssen immer mit der Oberseite nach oben zeigen, wenn sie miteinander verbunden werden.
- (IT) Collega sempre la rotaia parte superiore a parte superiore in tutta la costruzione.
- (PT) Liga sempre a face superior da pista à face superior durante a montagem.
- (NL) Maak steeds de bovenkant van het spoor vast aan de bovenkant tijdens de opbouw.



It comes in two different shapes.

- (FR) Il est fait dans deux différents styles.
- (ES) Esto viene a dos estilos diferentes.
- (DE) Es kommt in zwei verschiedenen Stilen.
- (IT) Si è fatto in due forme diverse.
- (PT) É feito em duas formas diferentes.
- (NL) Het is gemaakt in twee verschillende vormen.

1 - 97

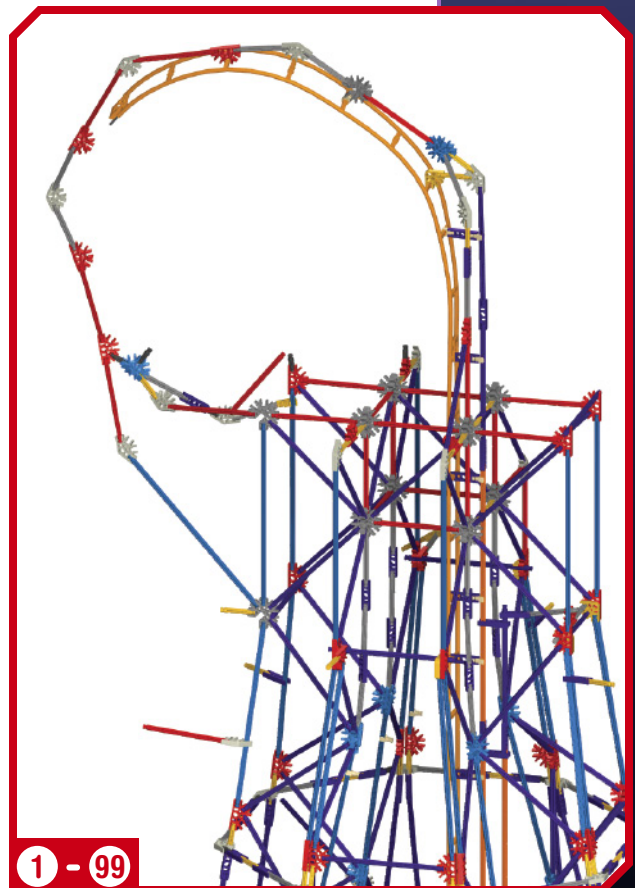

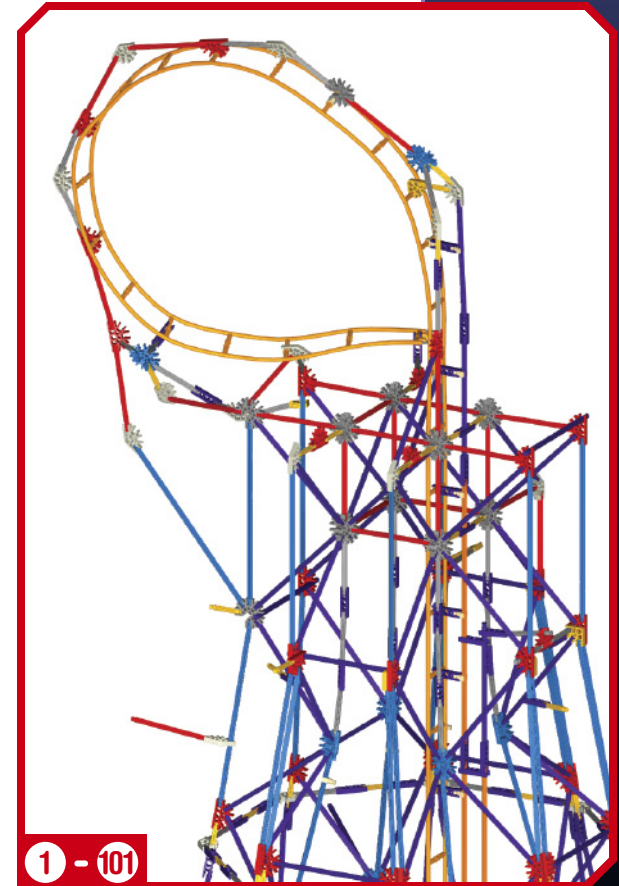
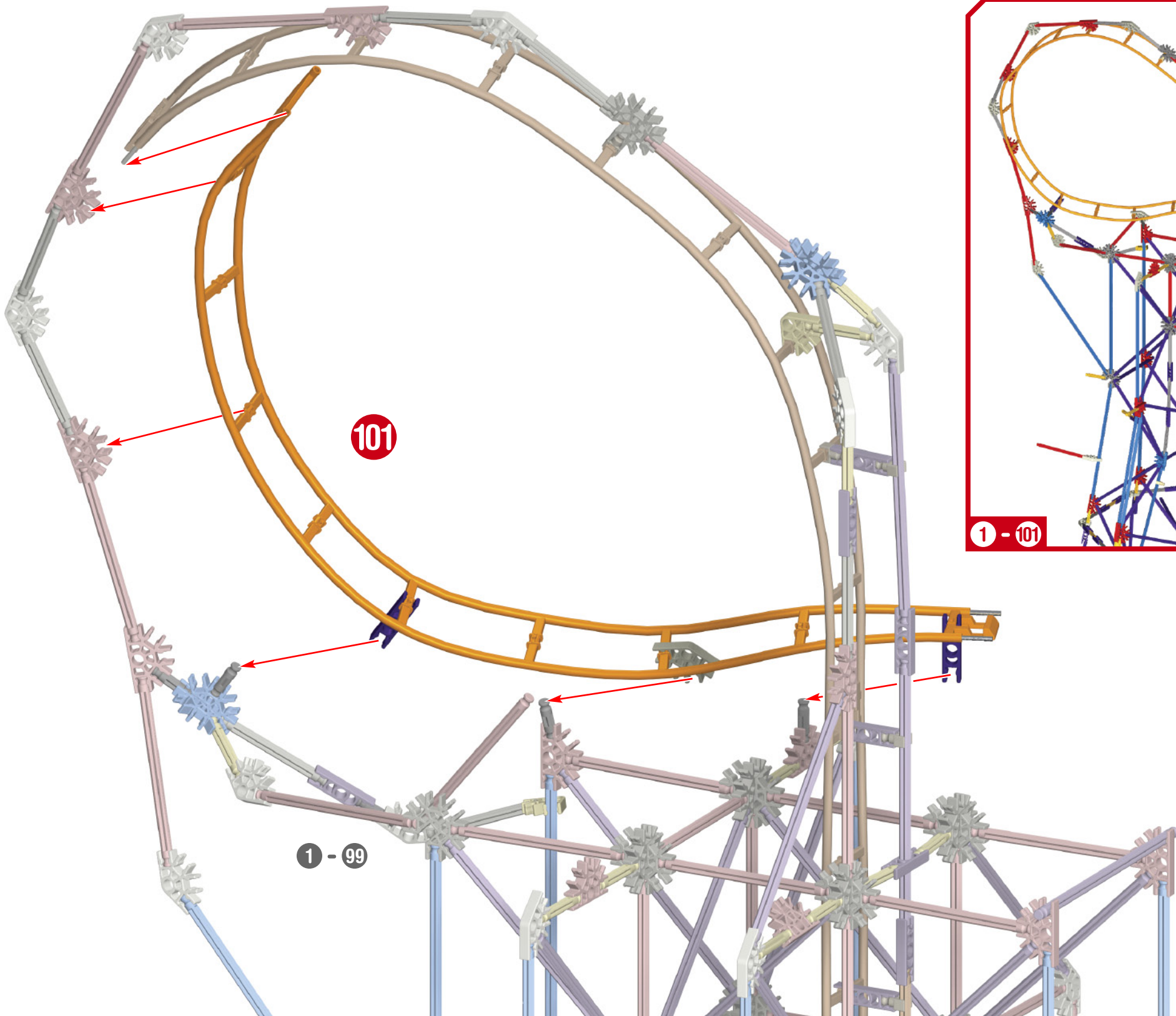
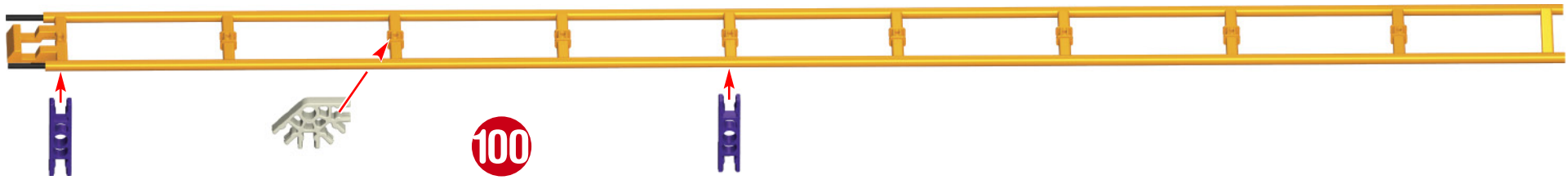



102



1 - 101

103

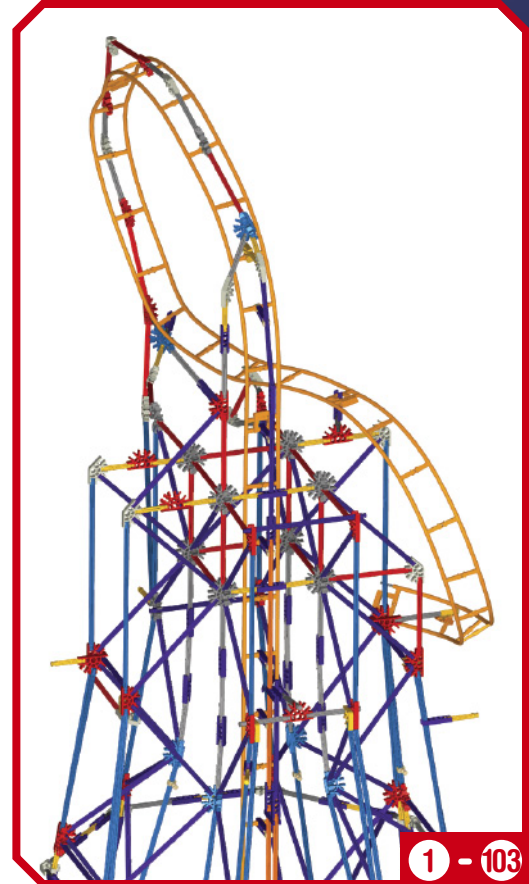

1 - 103

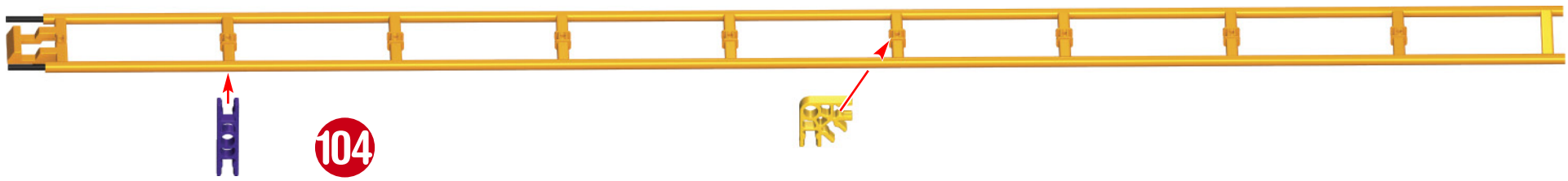

104

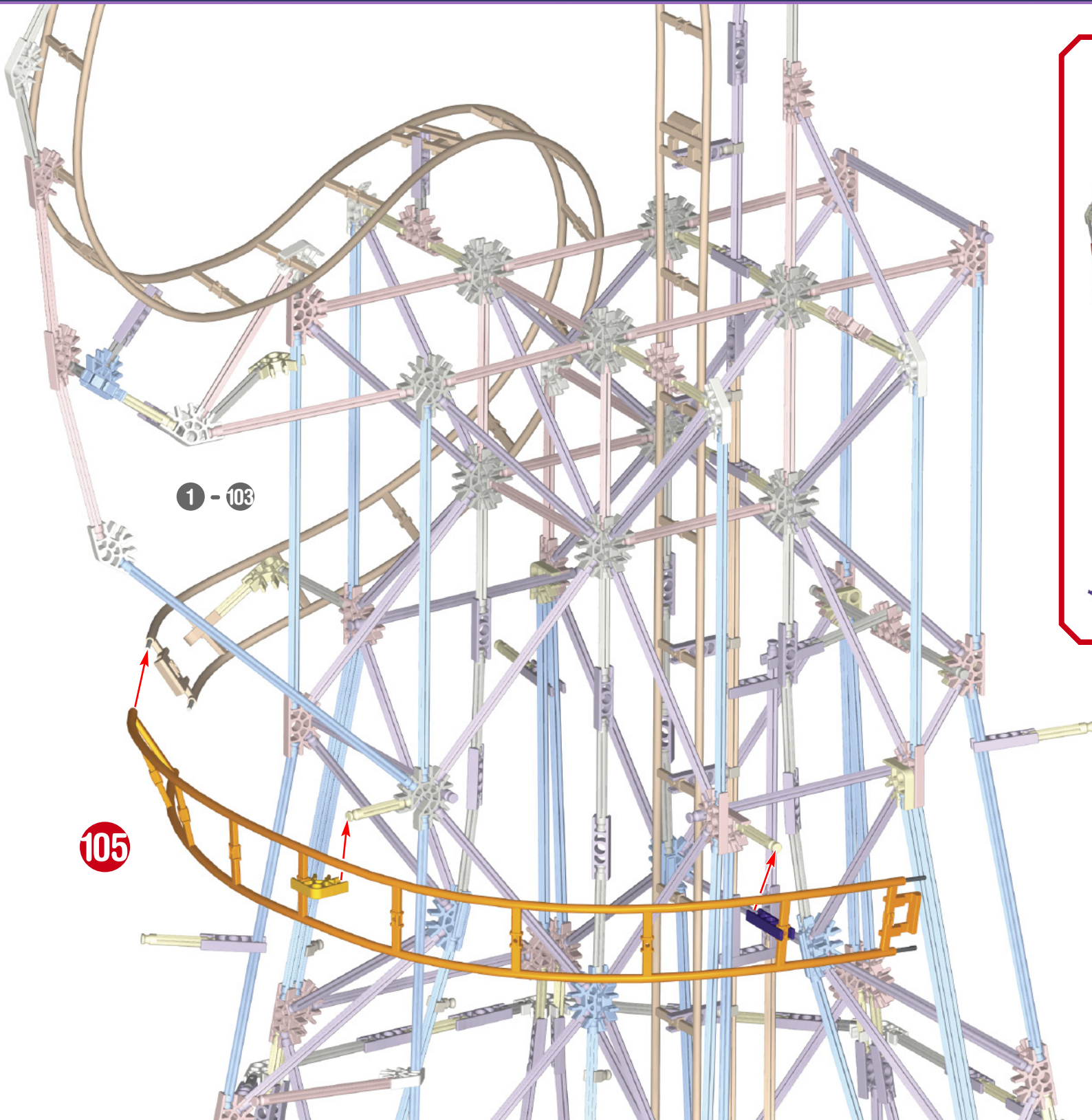

1 - 103

105

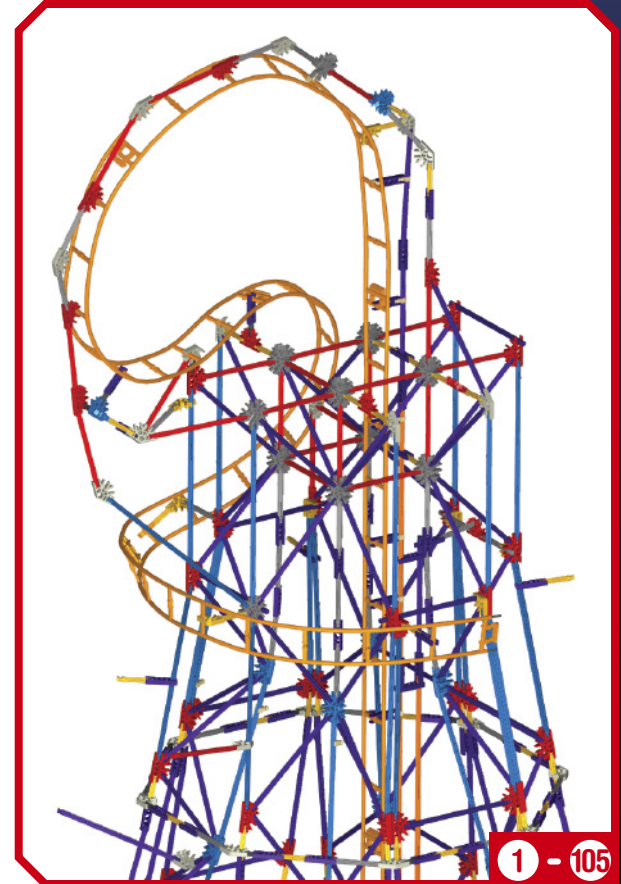

1 - 105

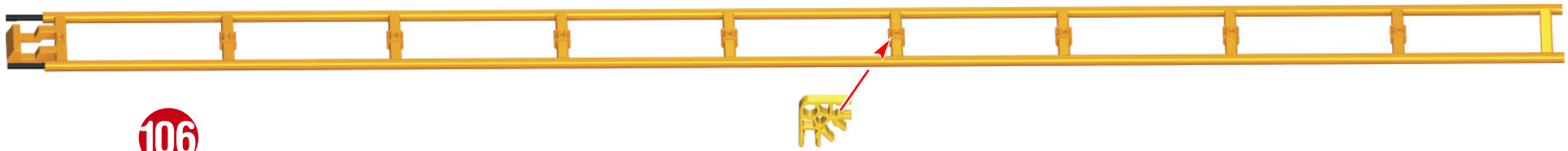

106

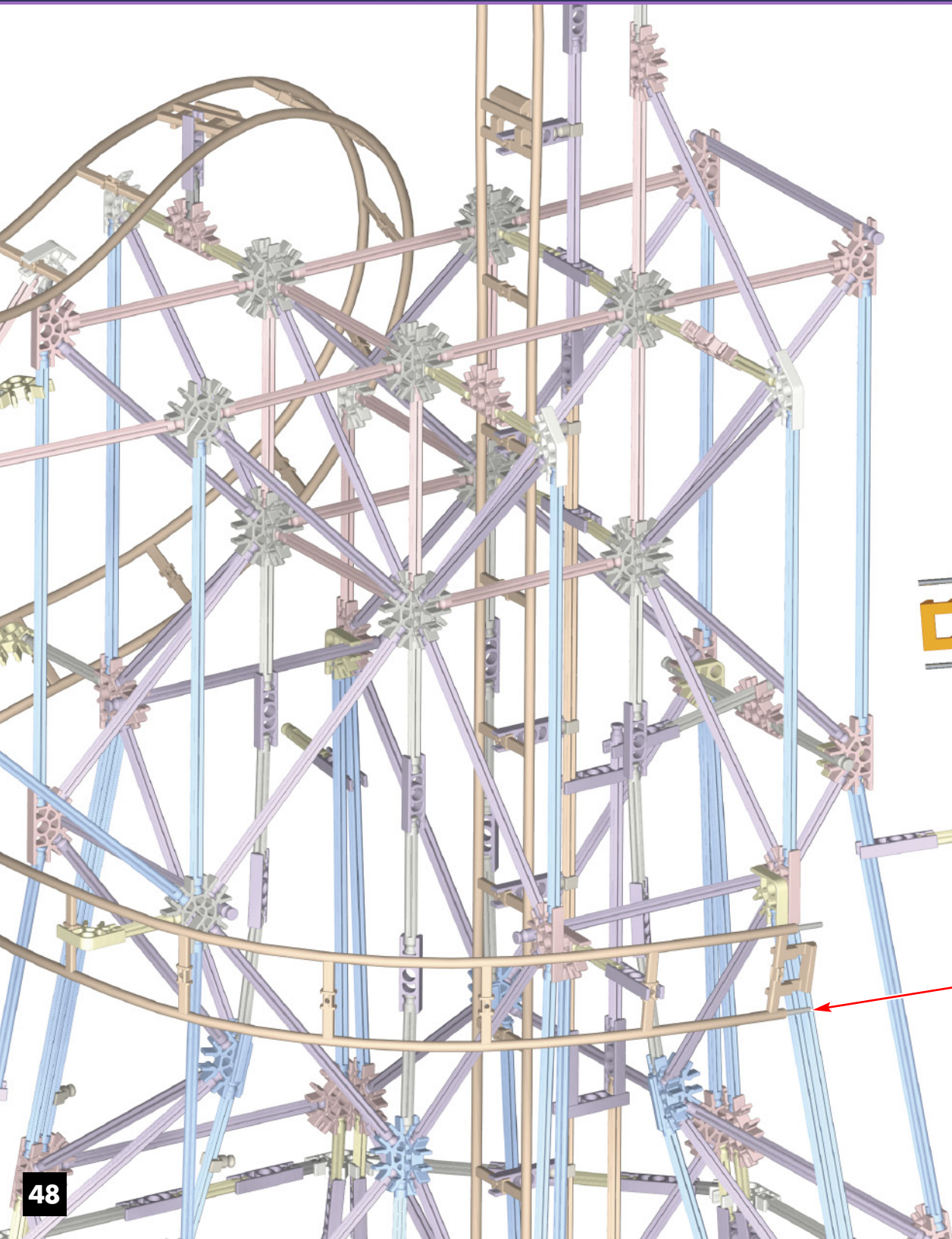

107

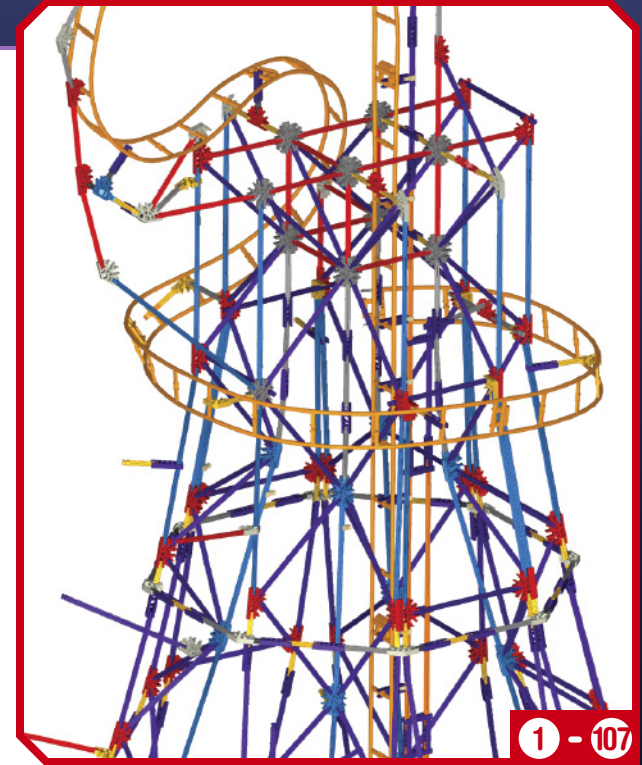

1 - 107

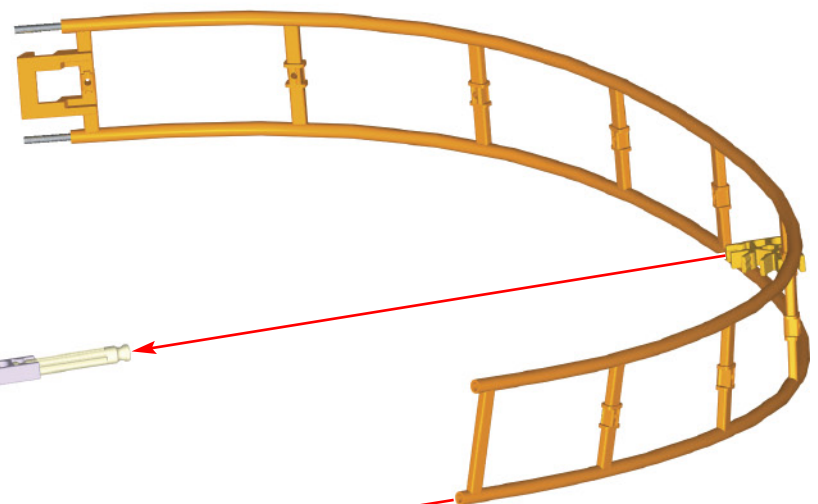

1 - 105



108

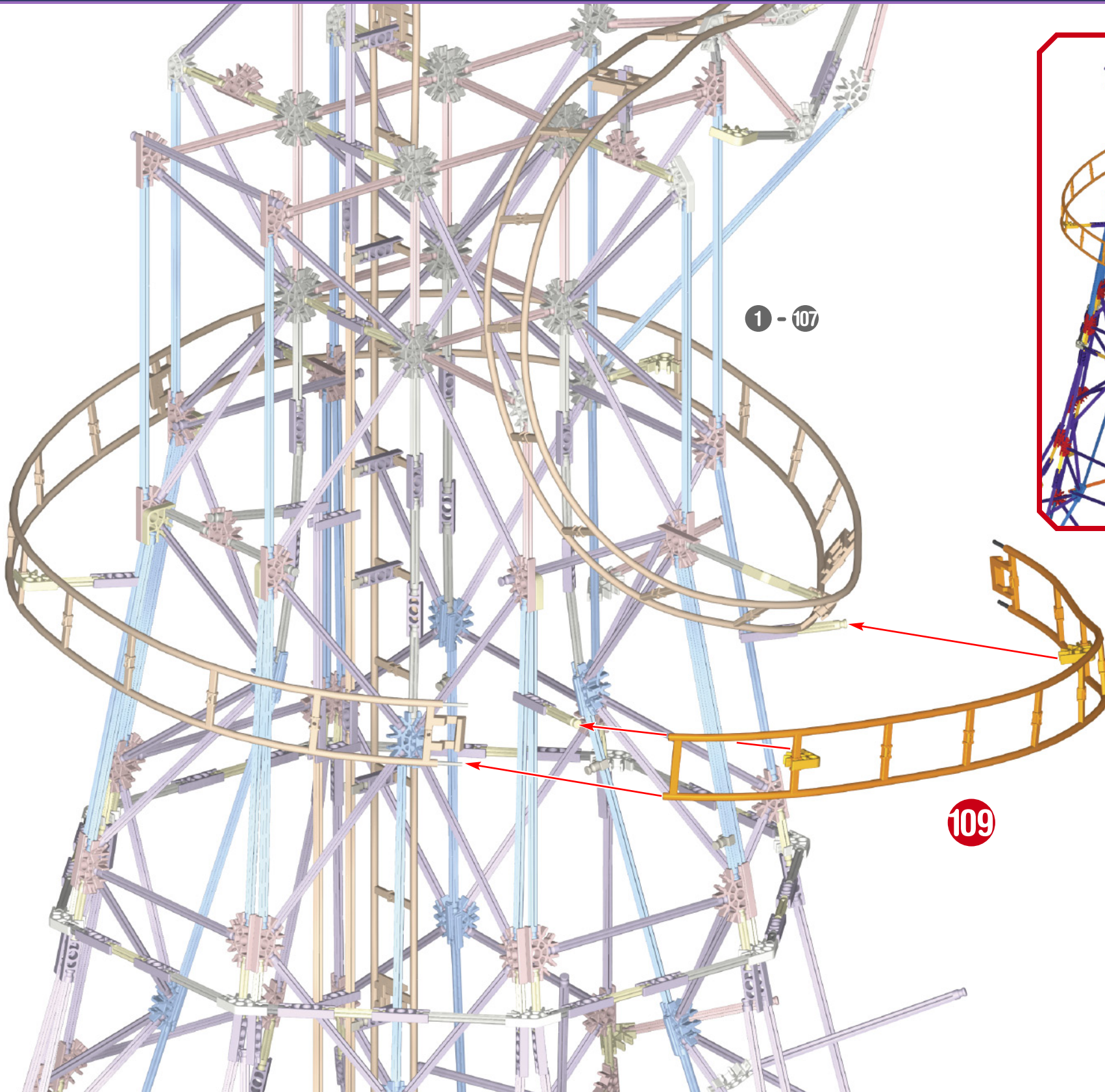

1 - 107

109

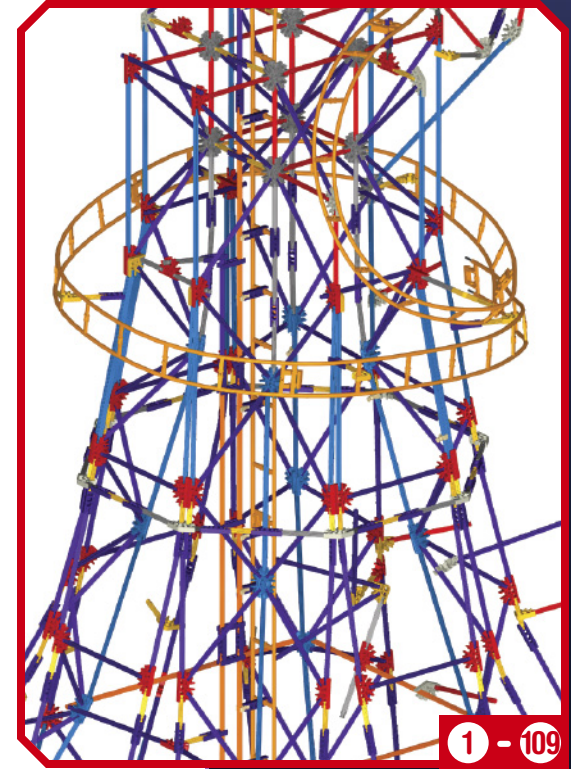

1 - 109

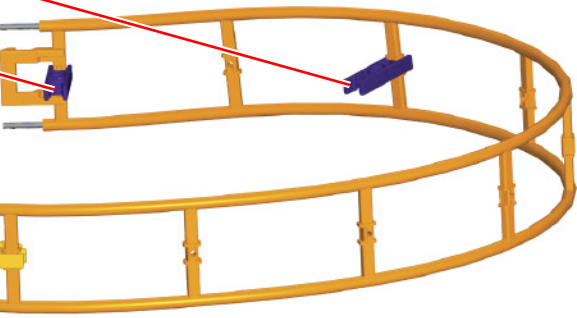
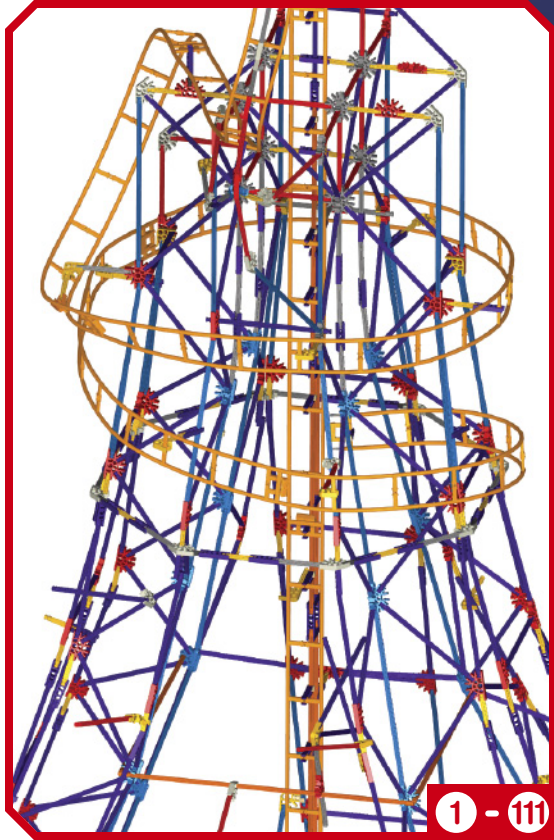
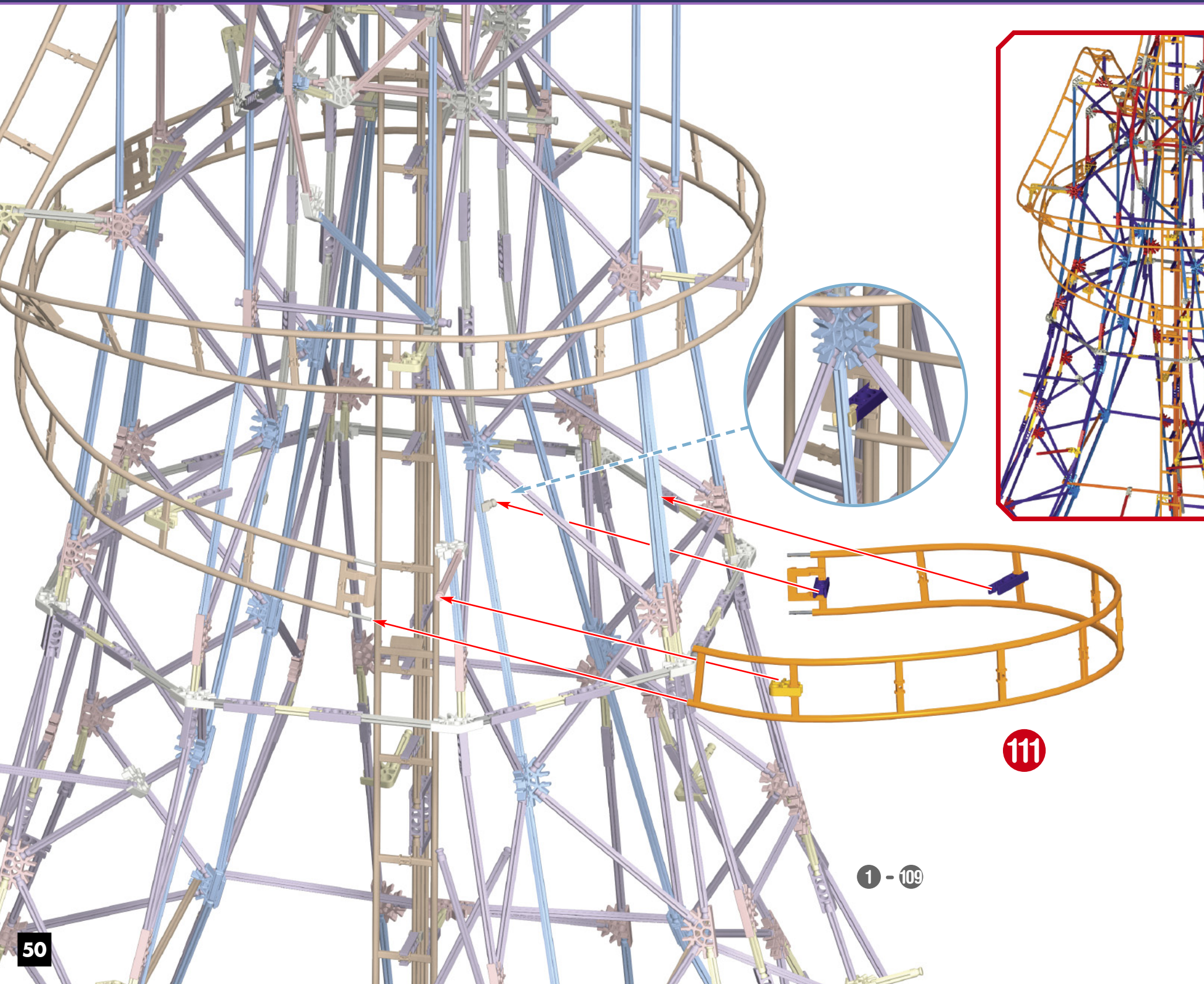
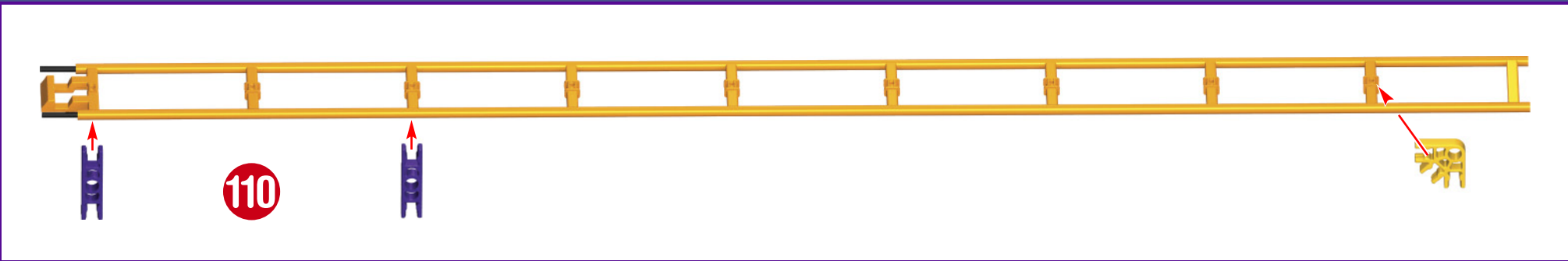

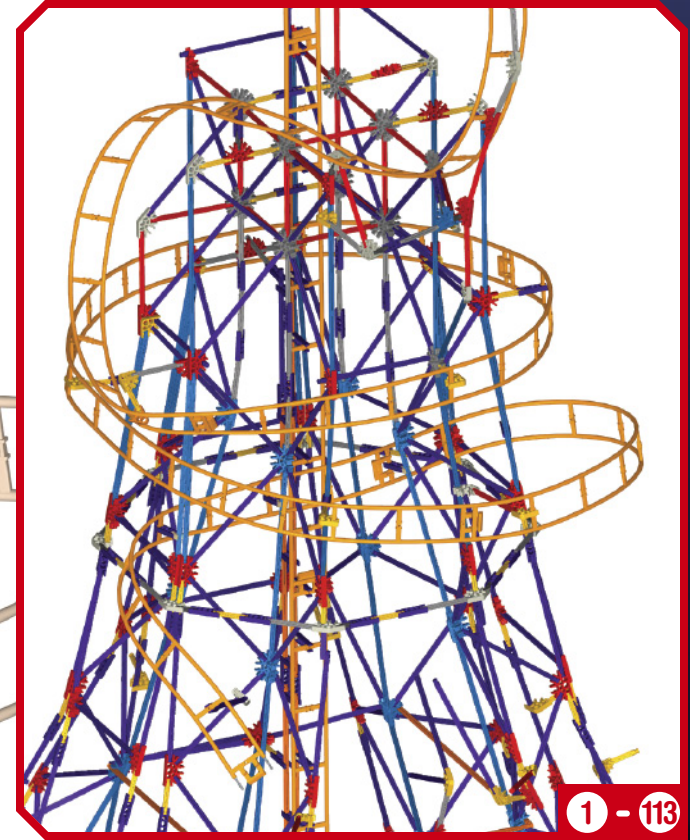
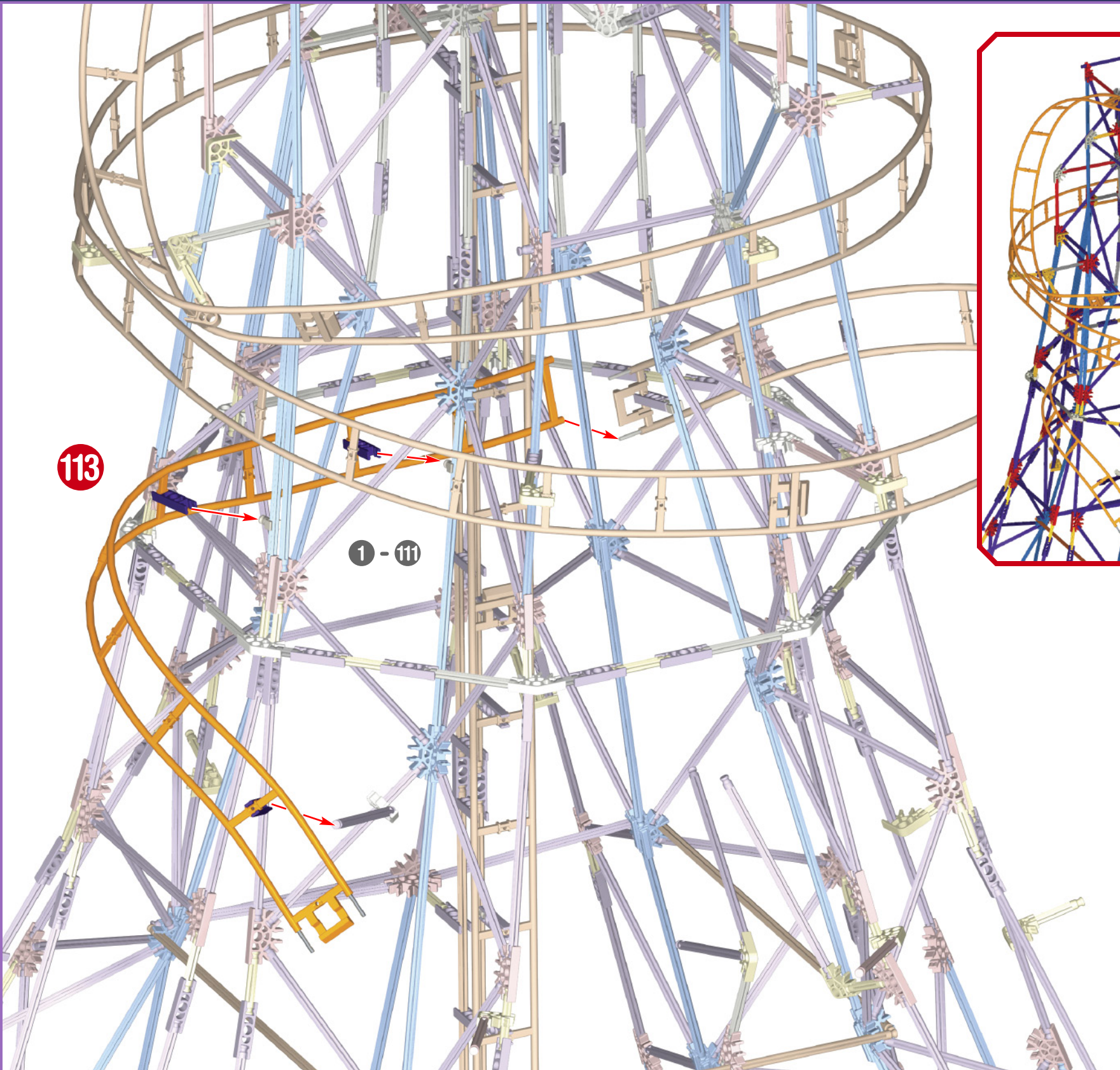

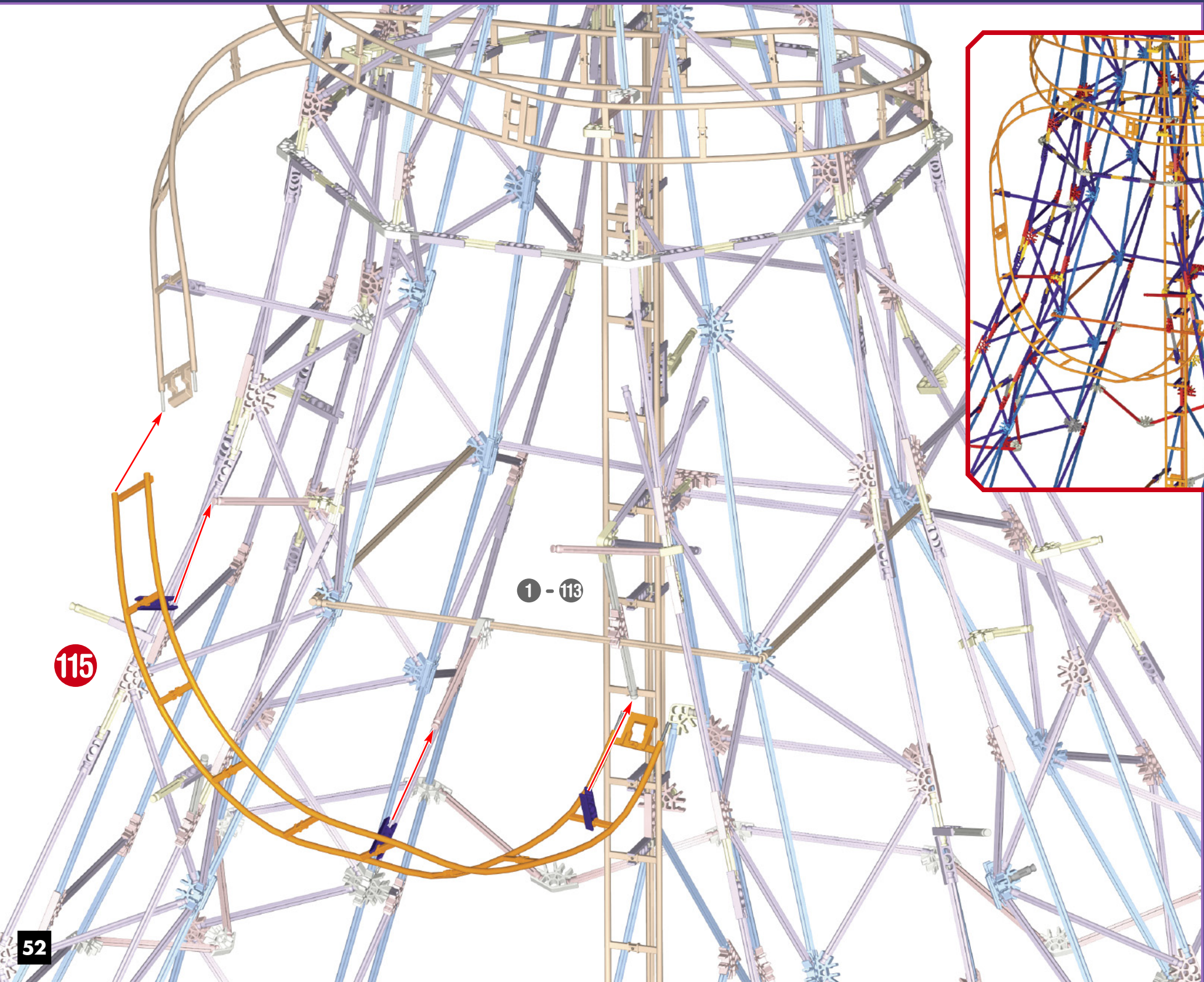
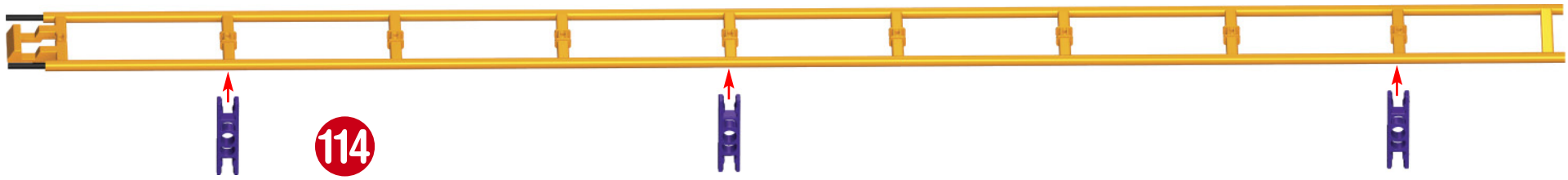

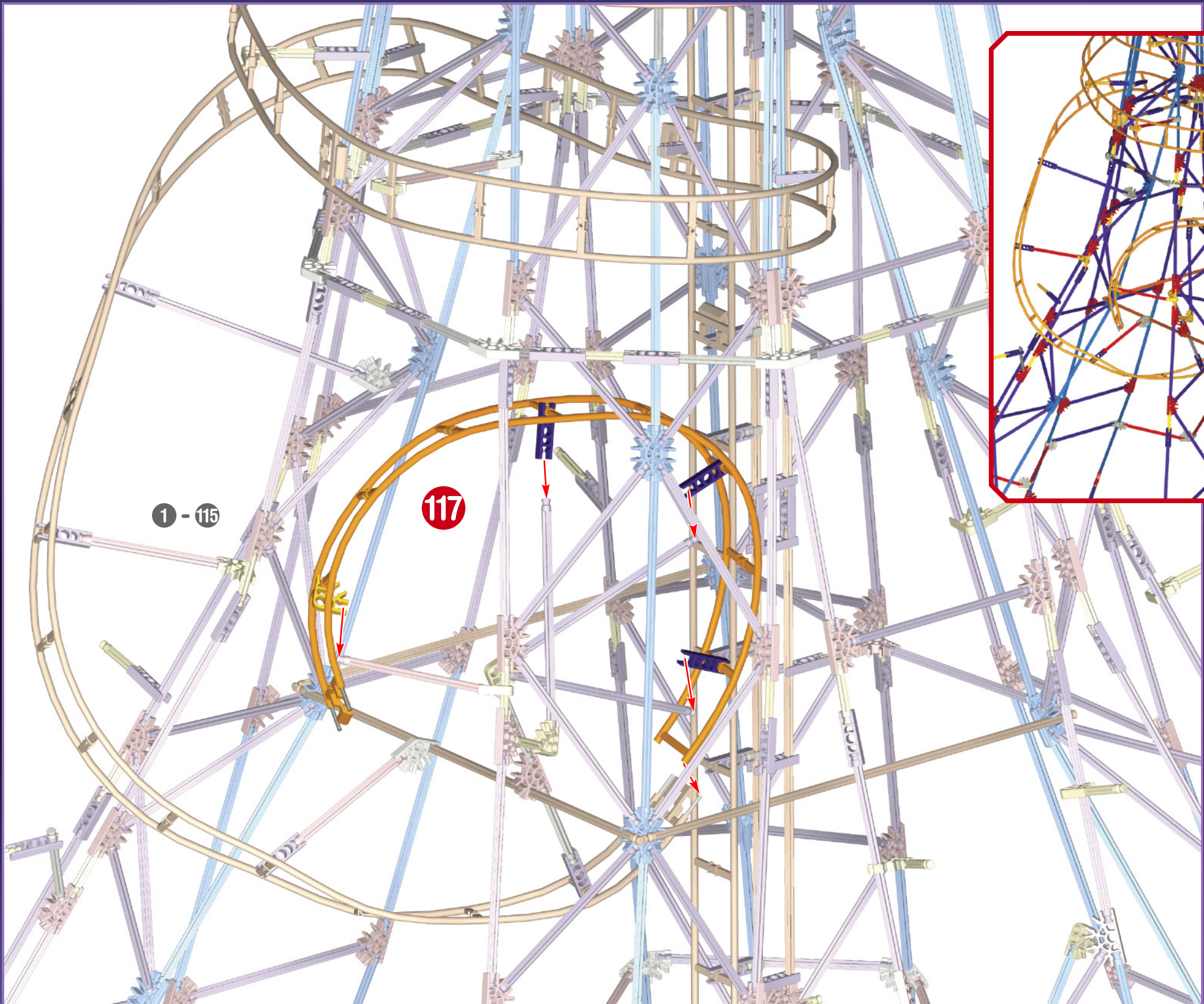
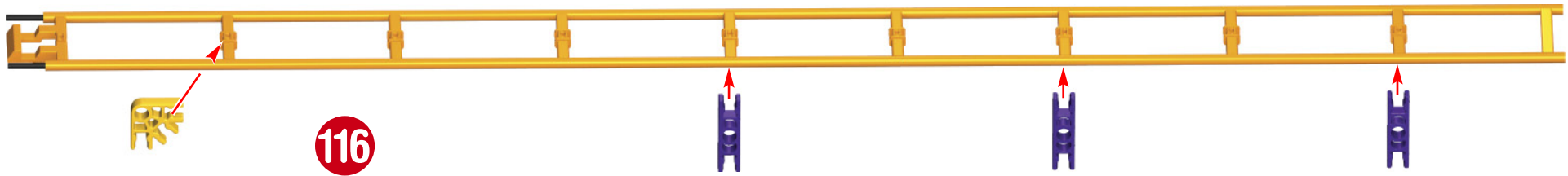

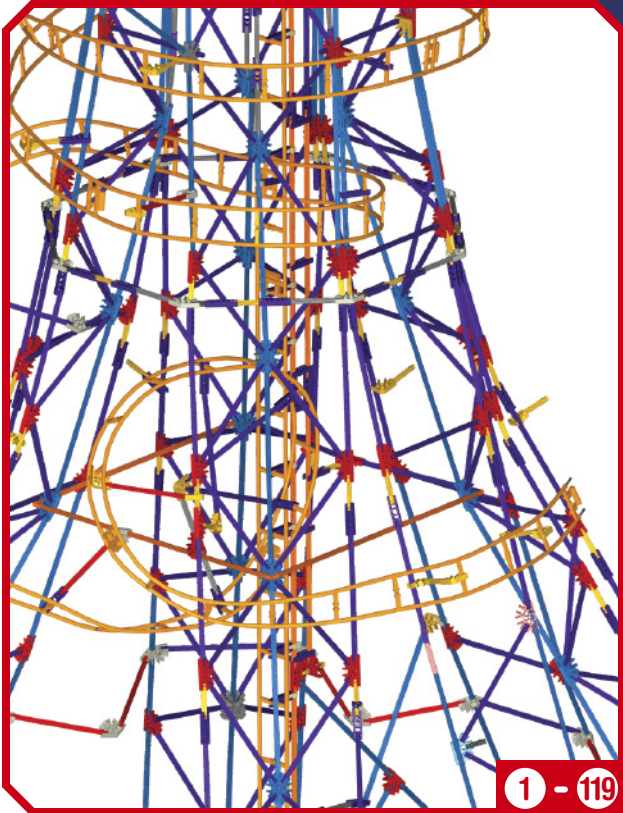
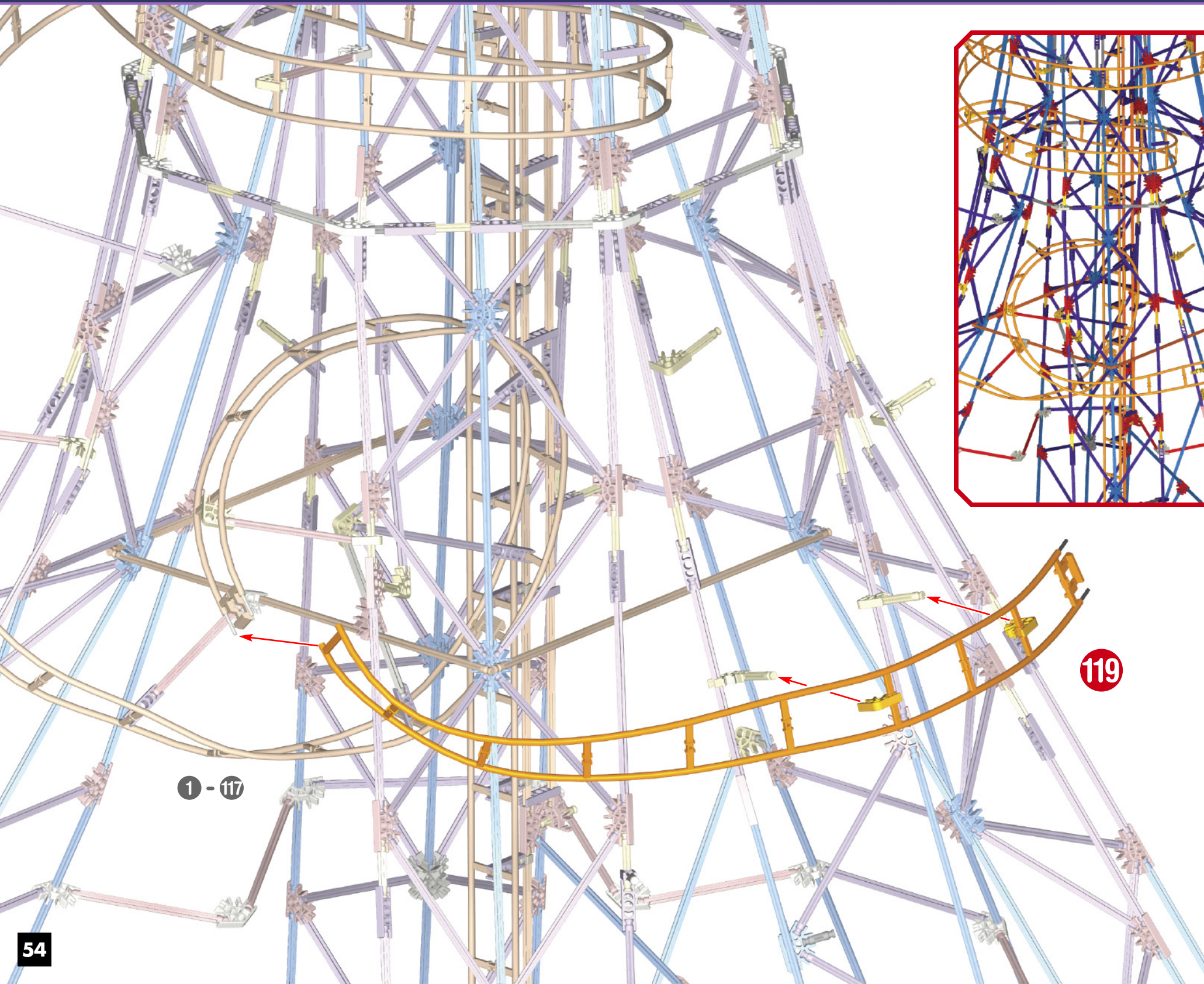
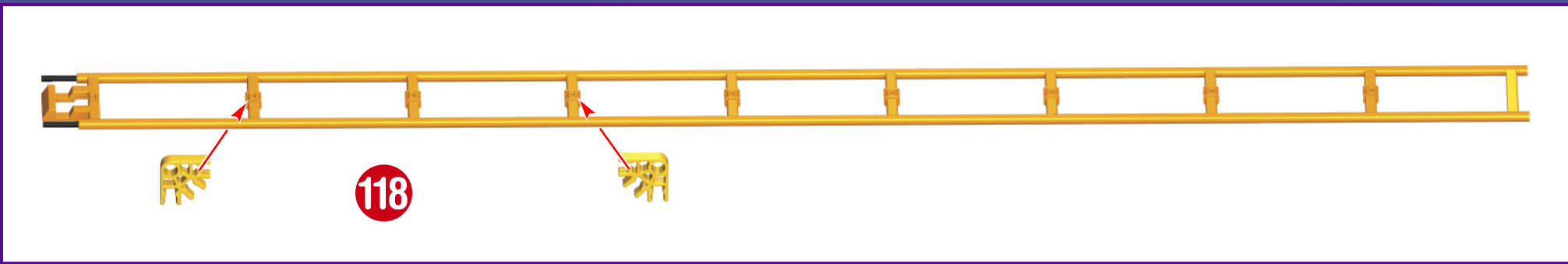

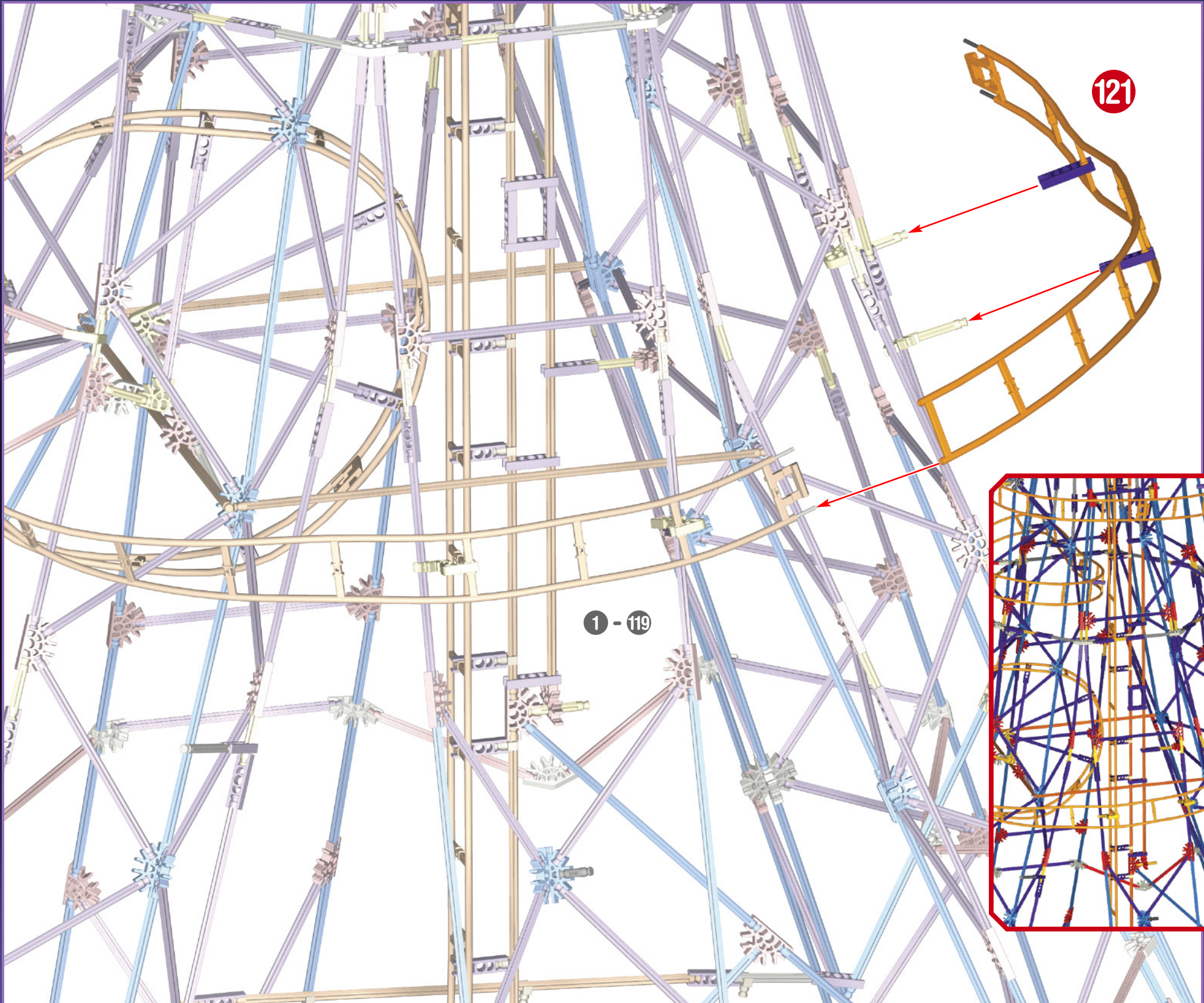

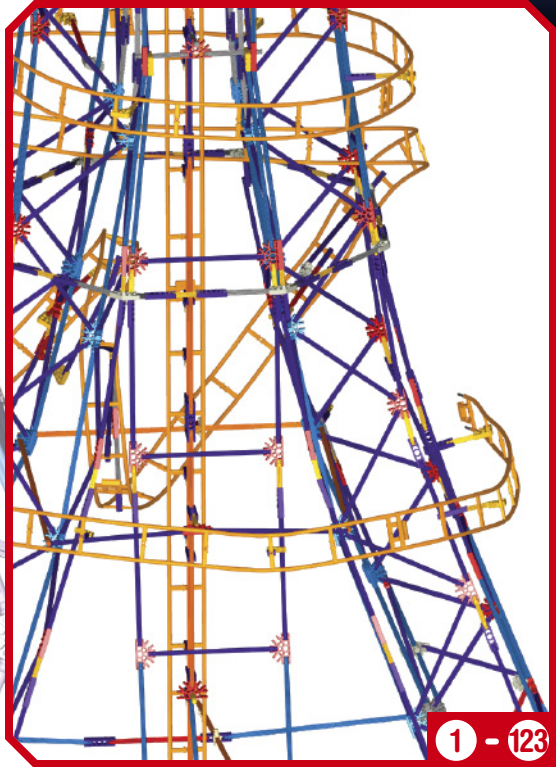
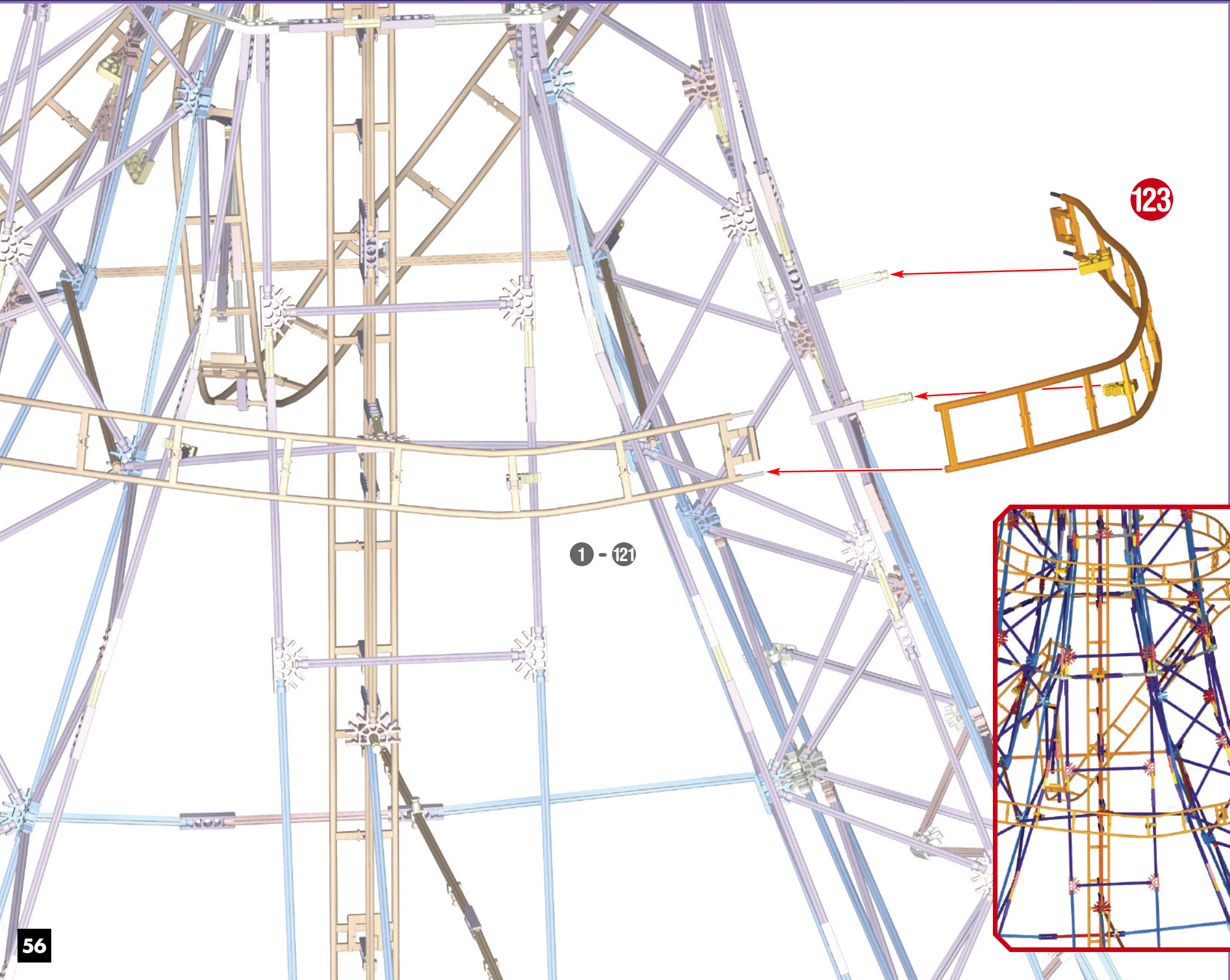
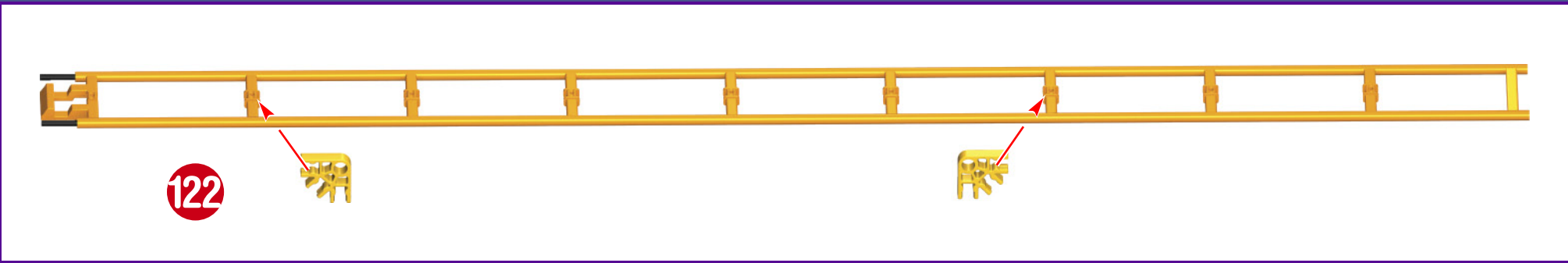



124

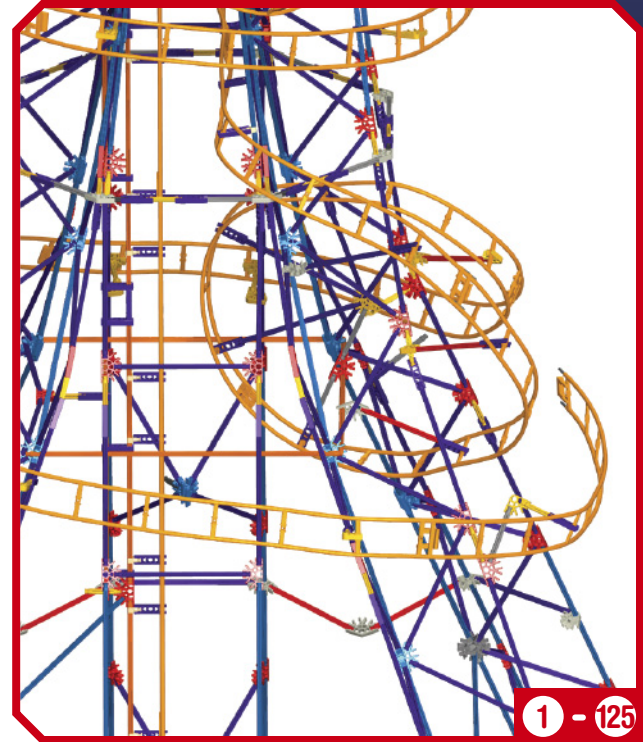
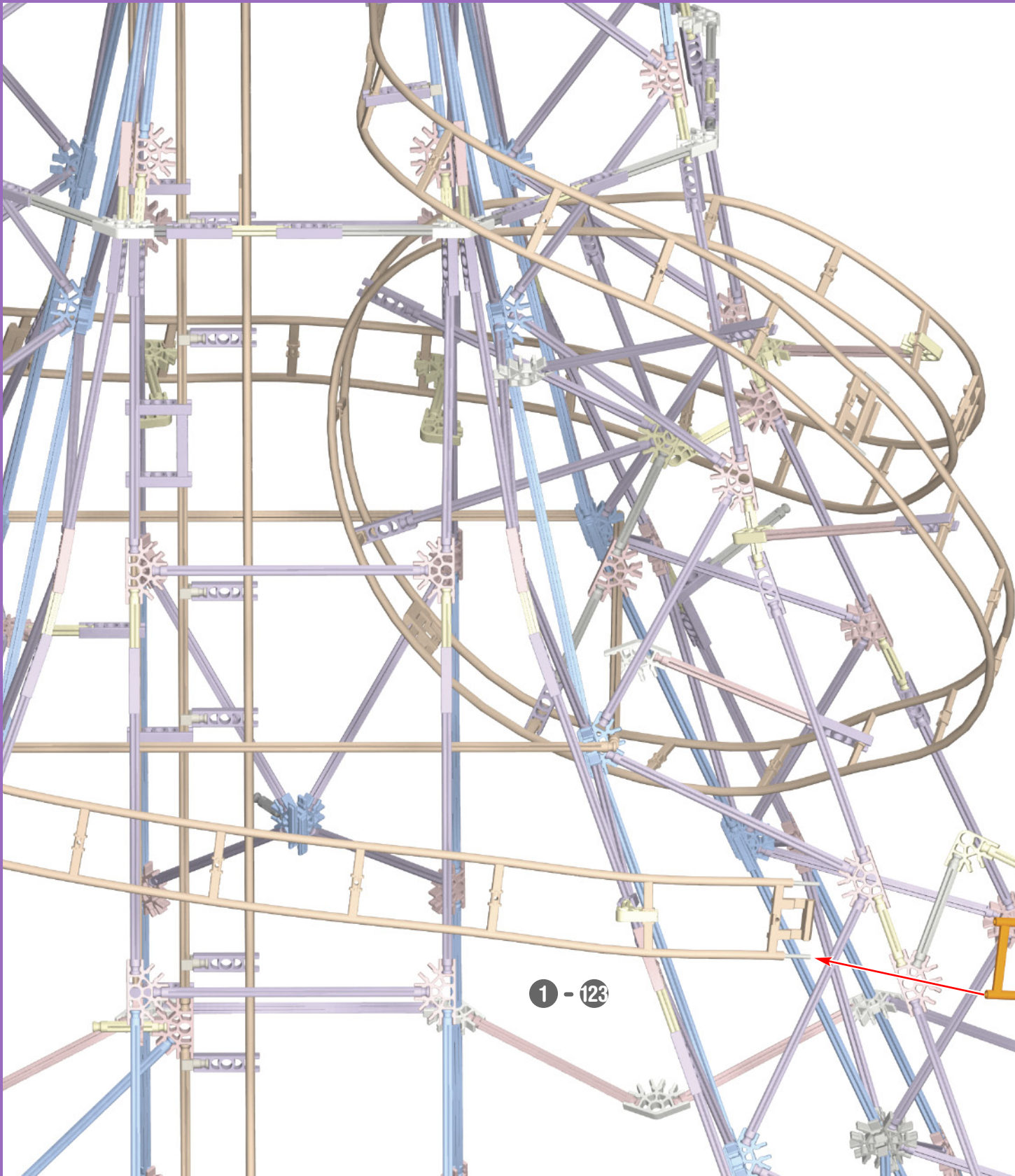

1 - 125

125

1 - 123

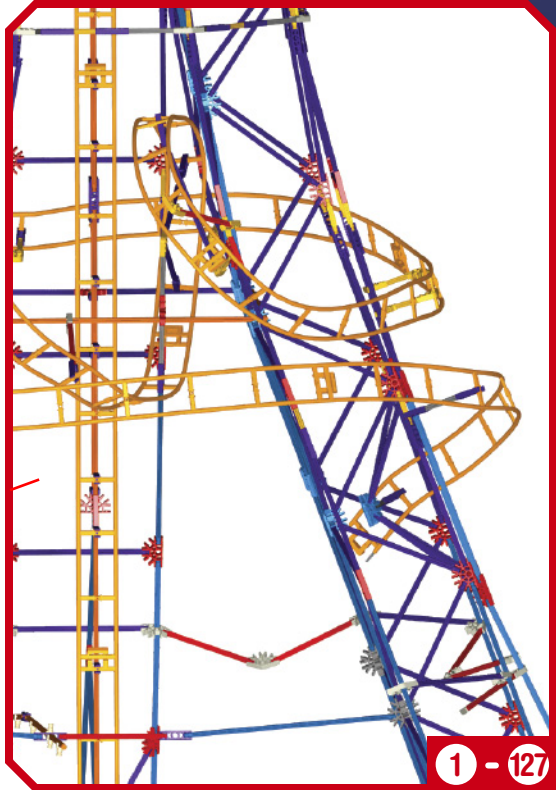
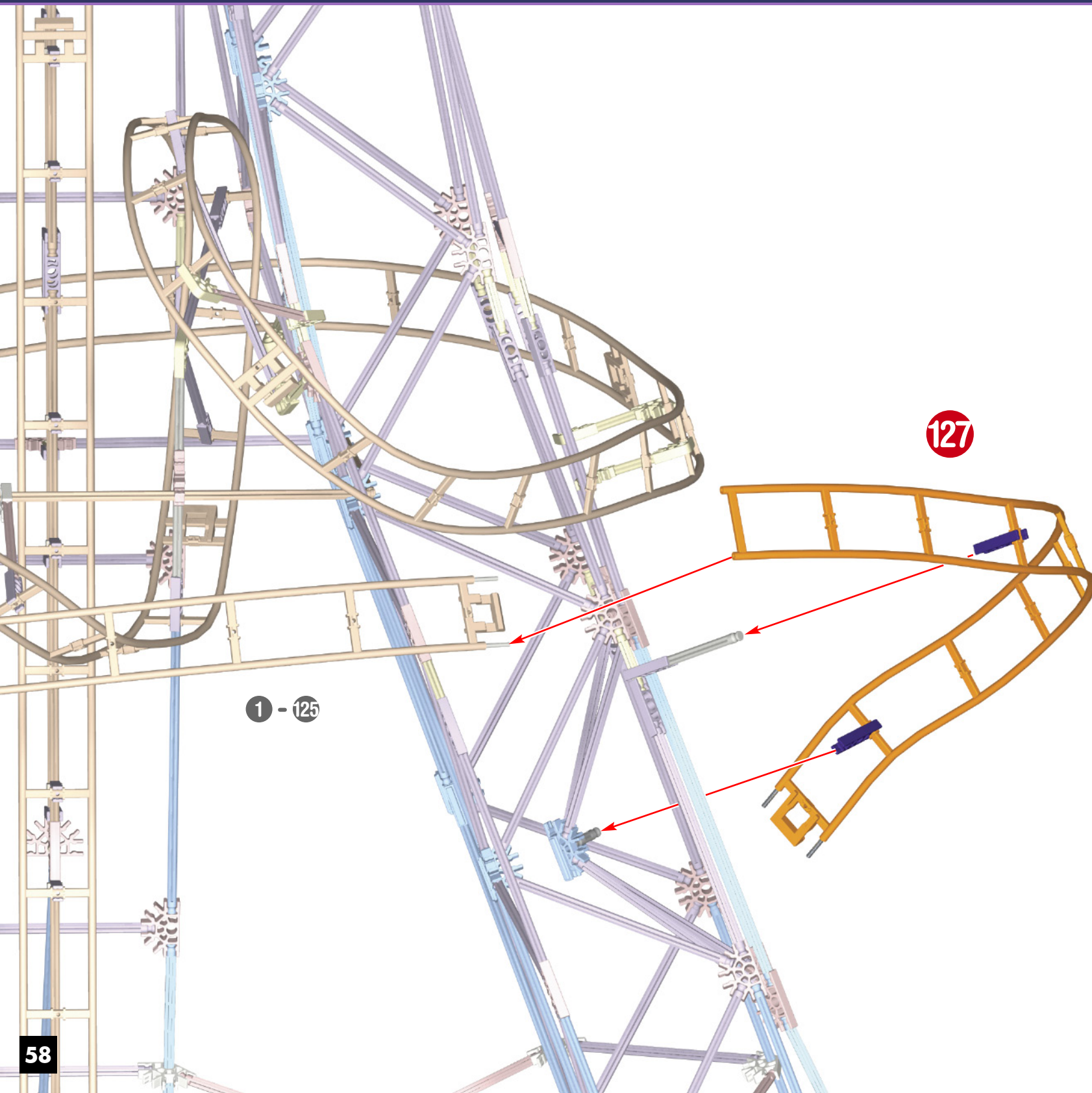
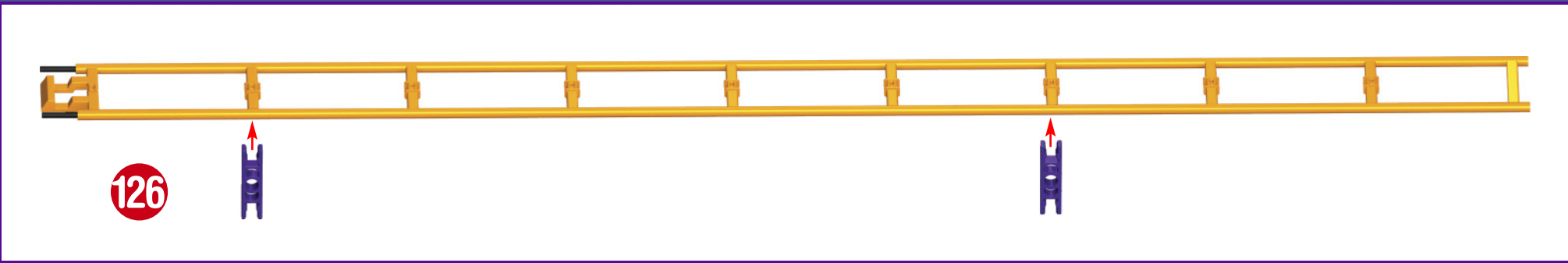



128

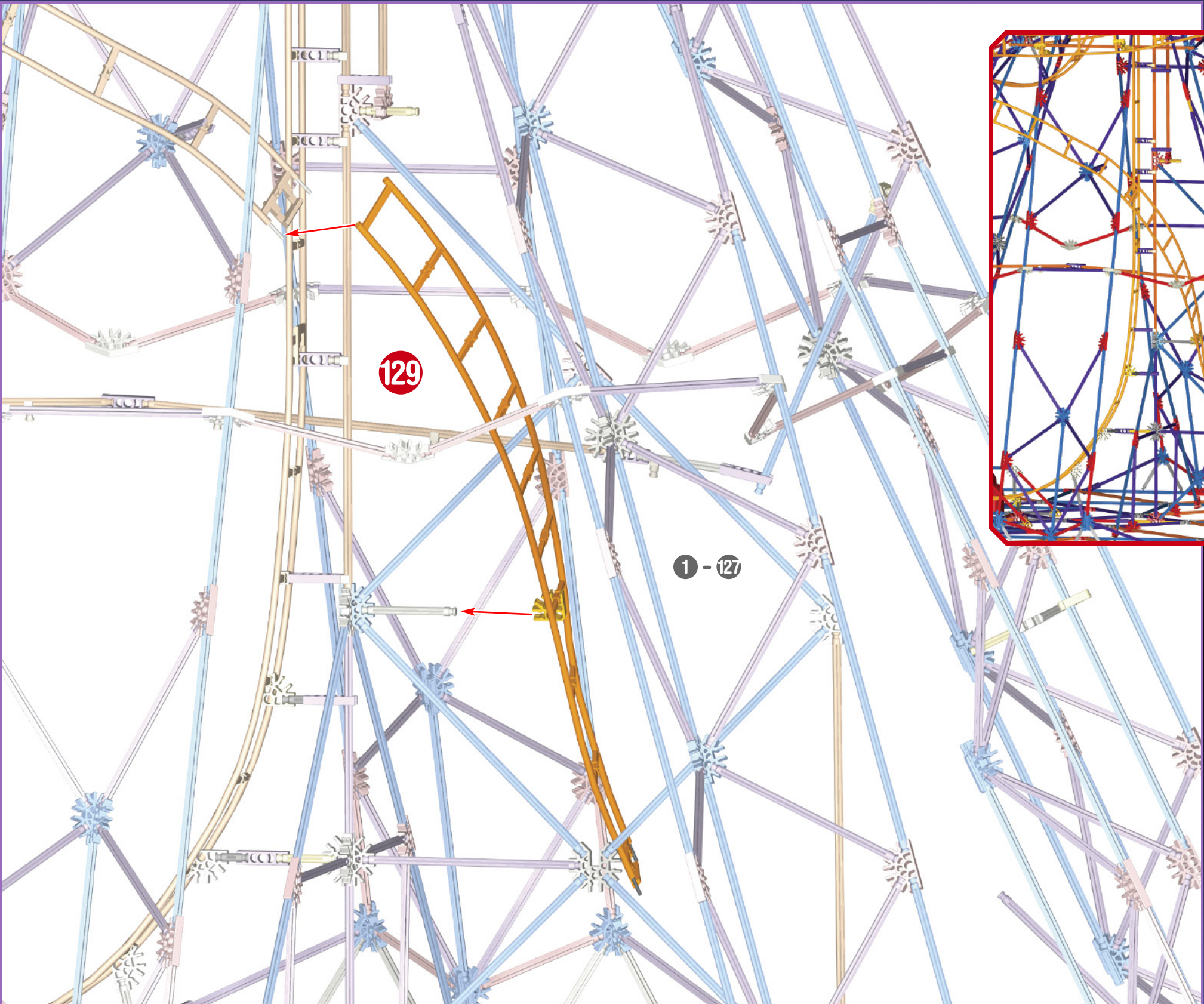

129

1 - 127

1 - 129

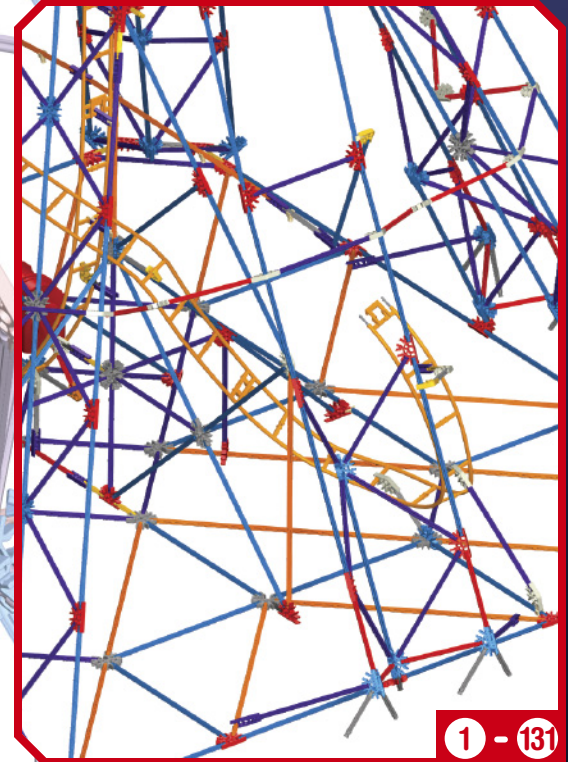
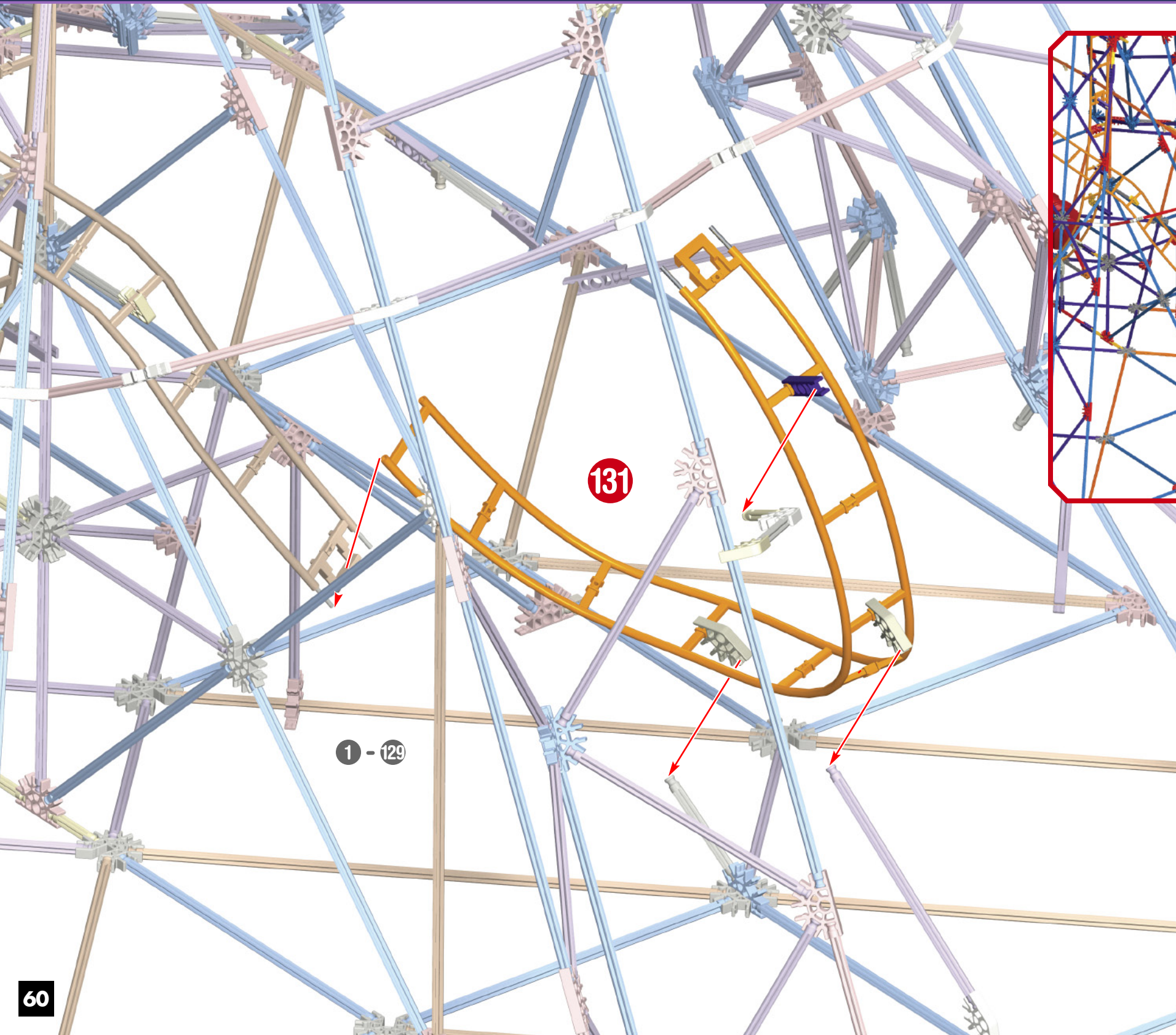
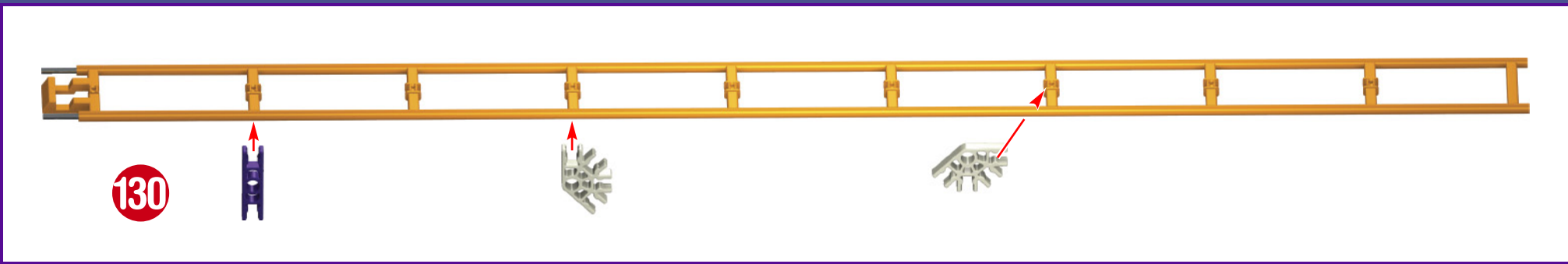

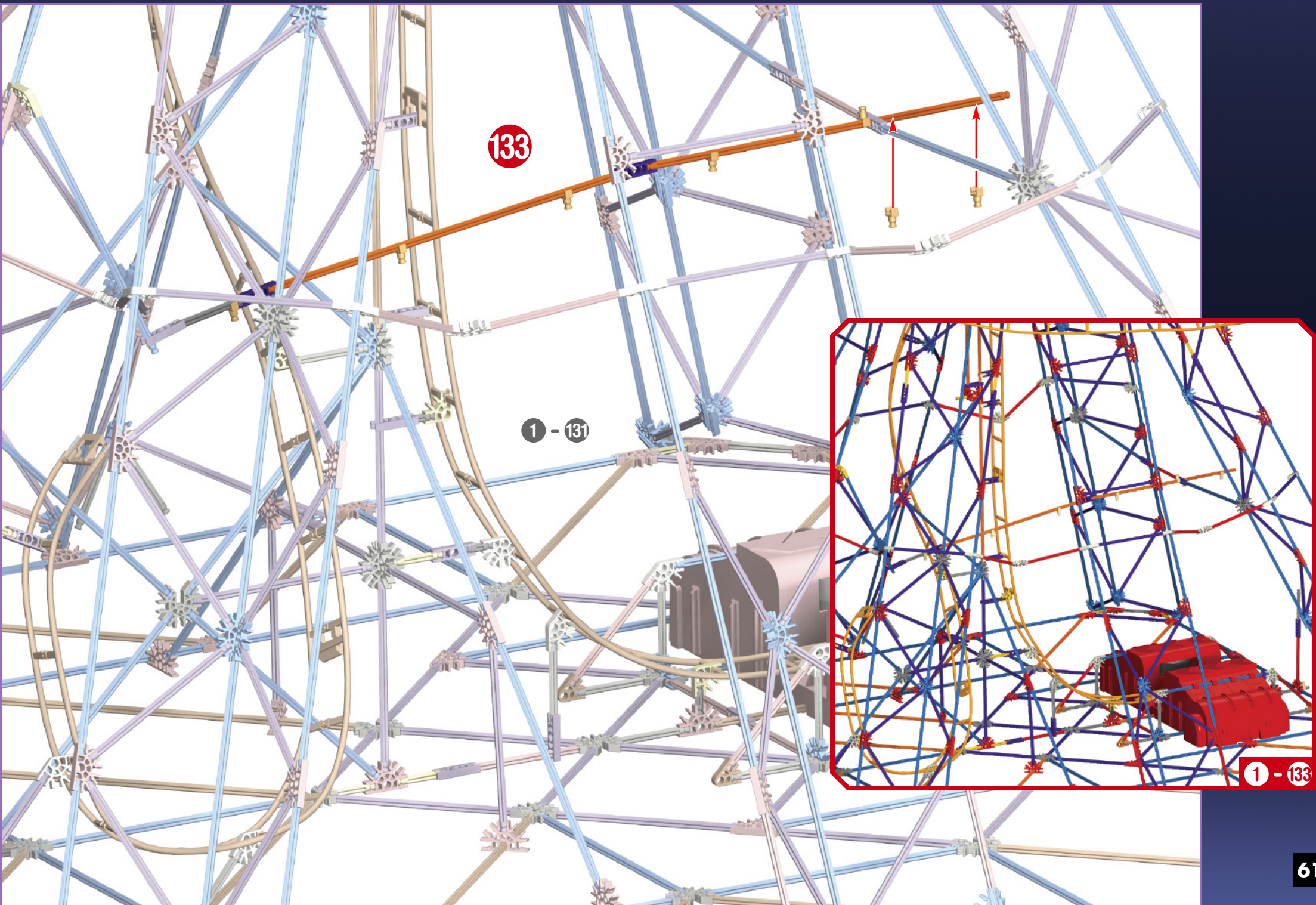
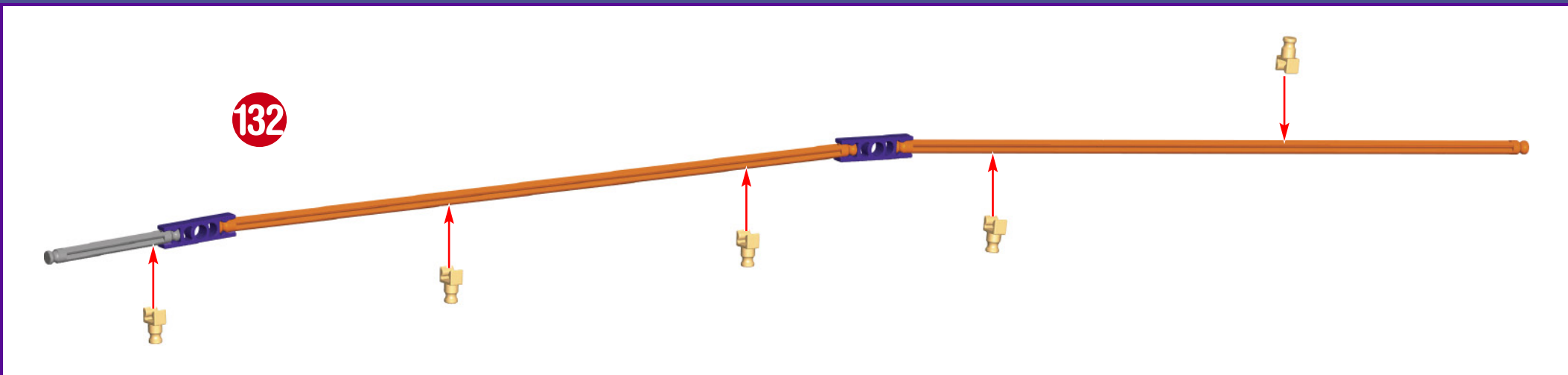

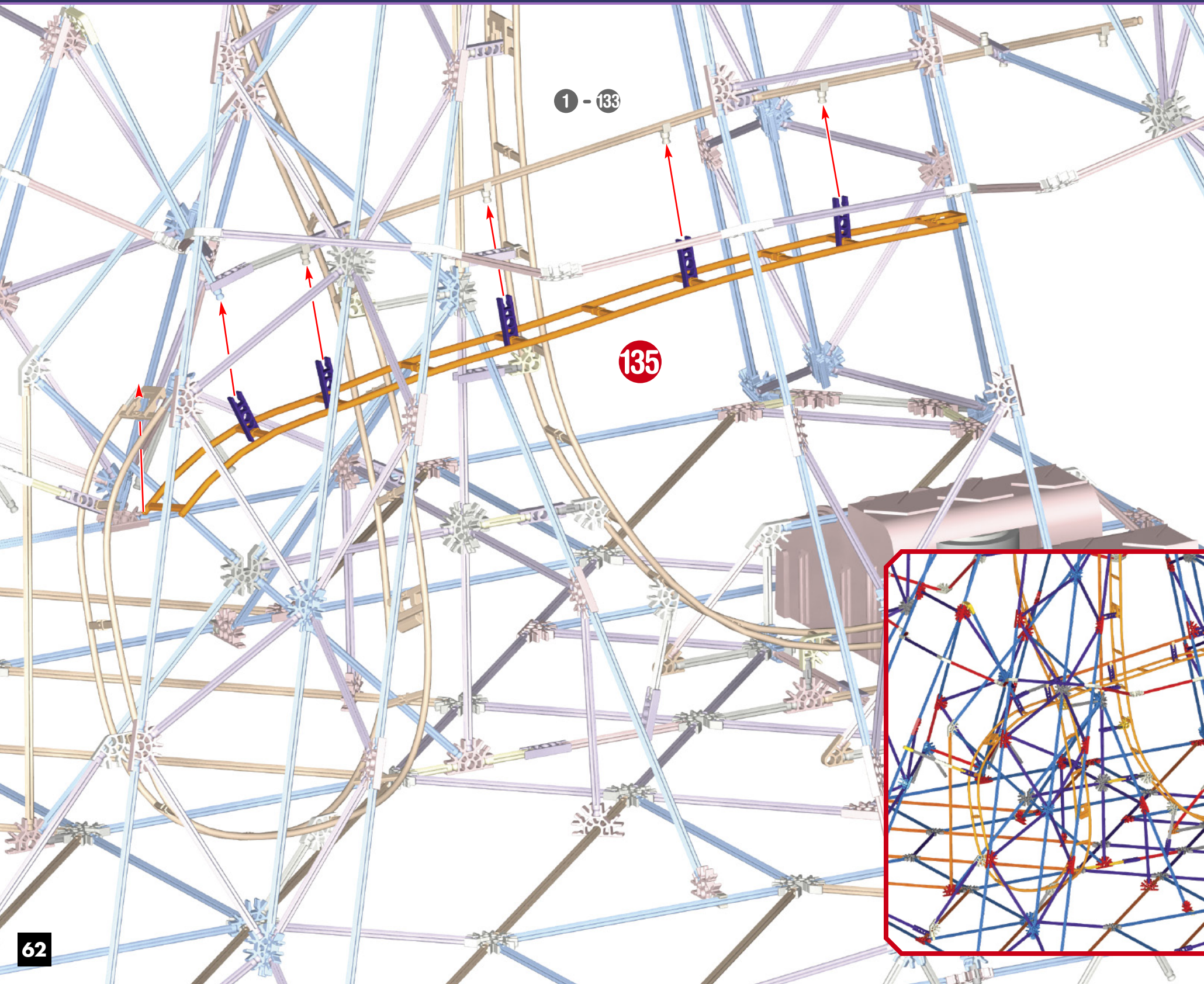
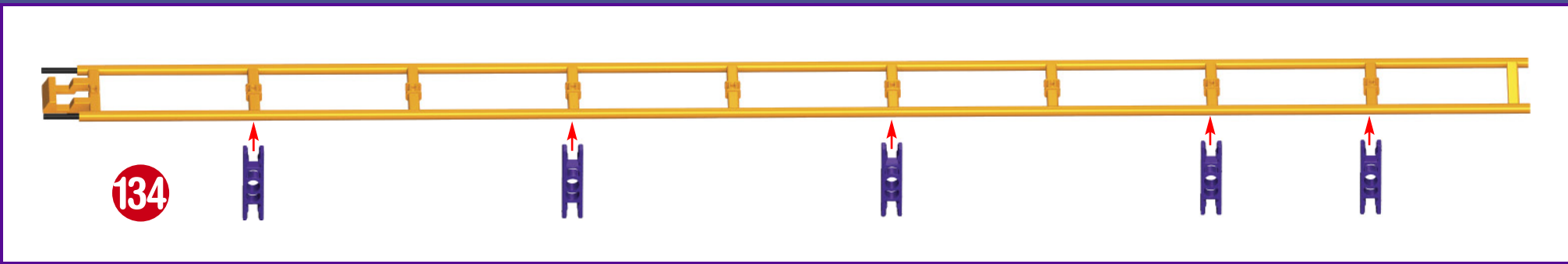

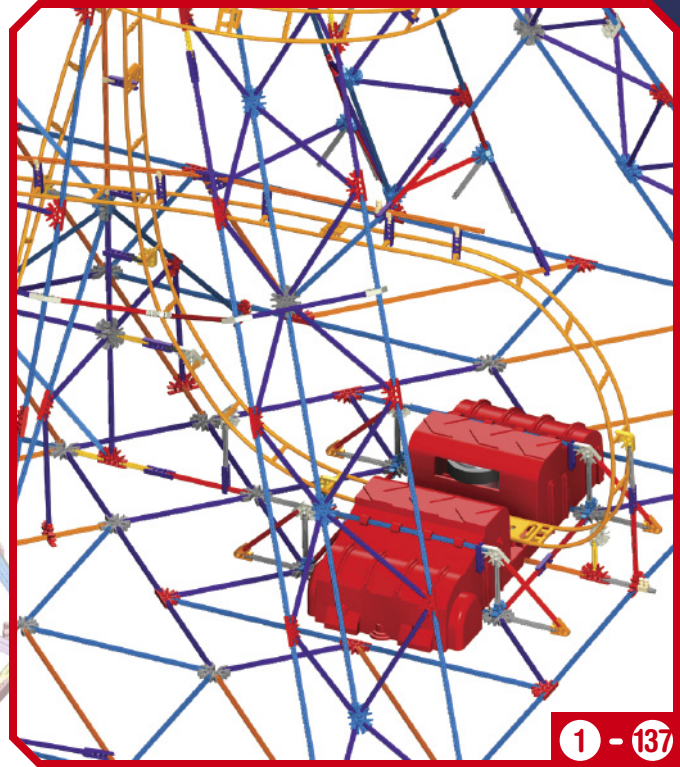
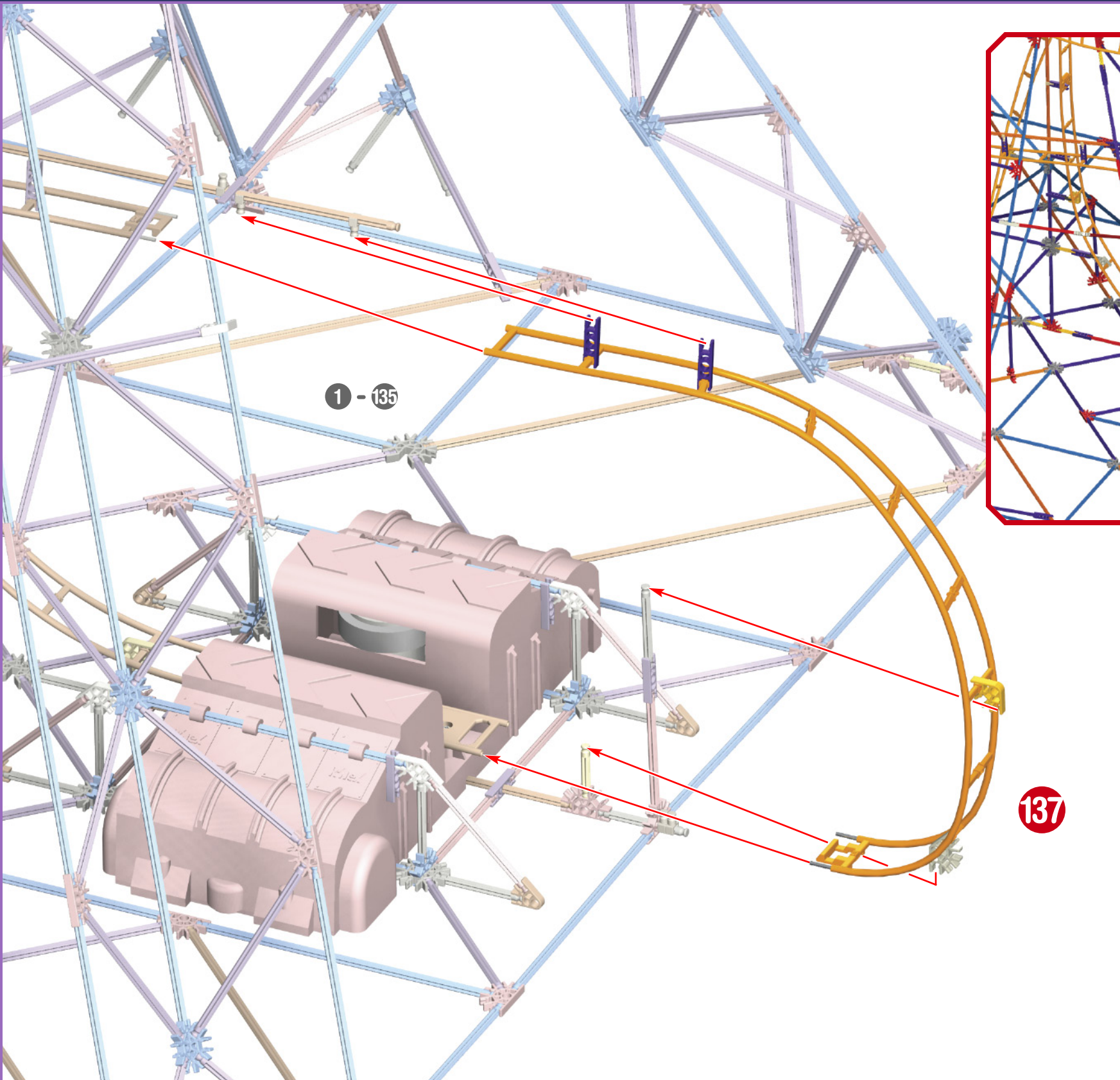
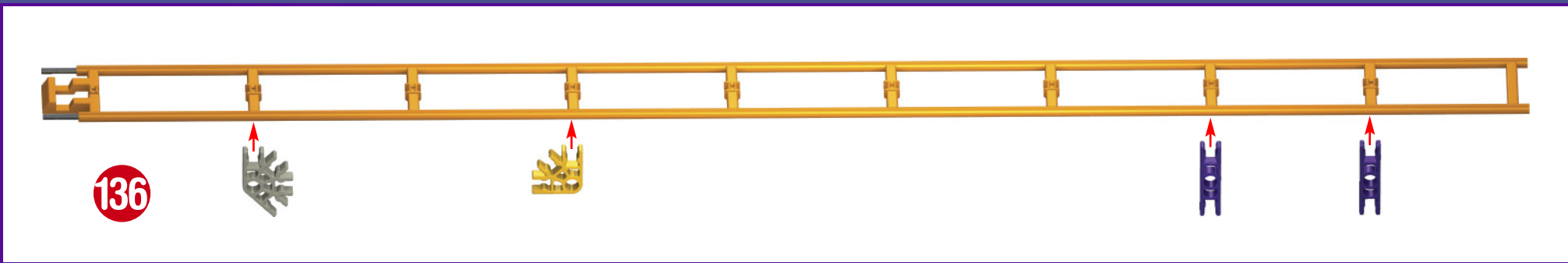

# Attaching Graphic Panels

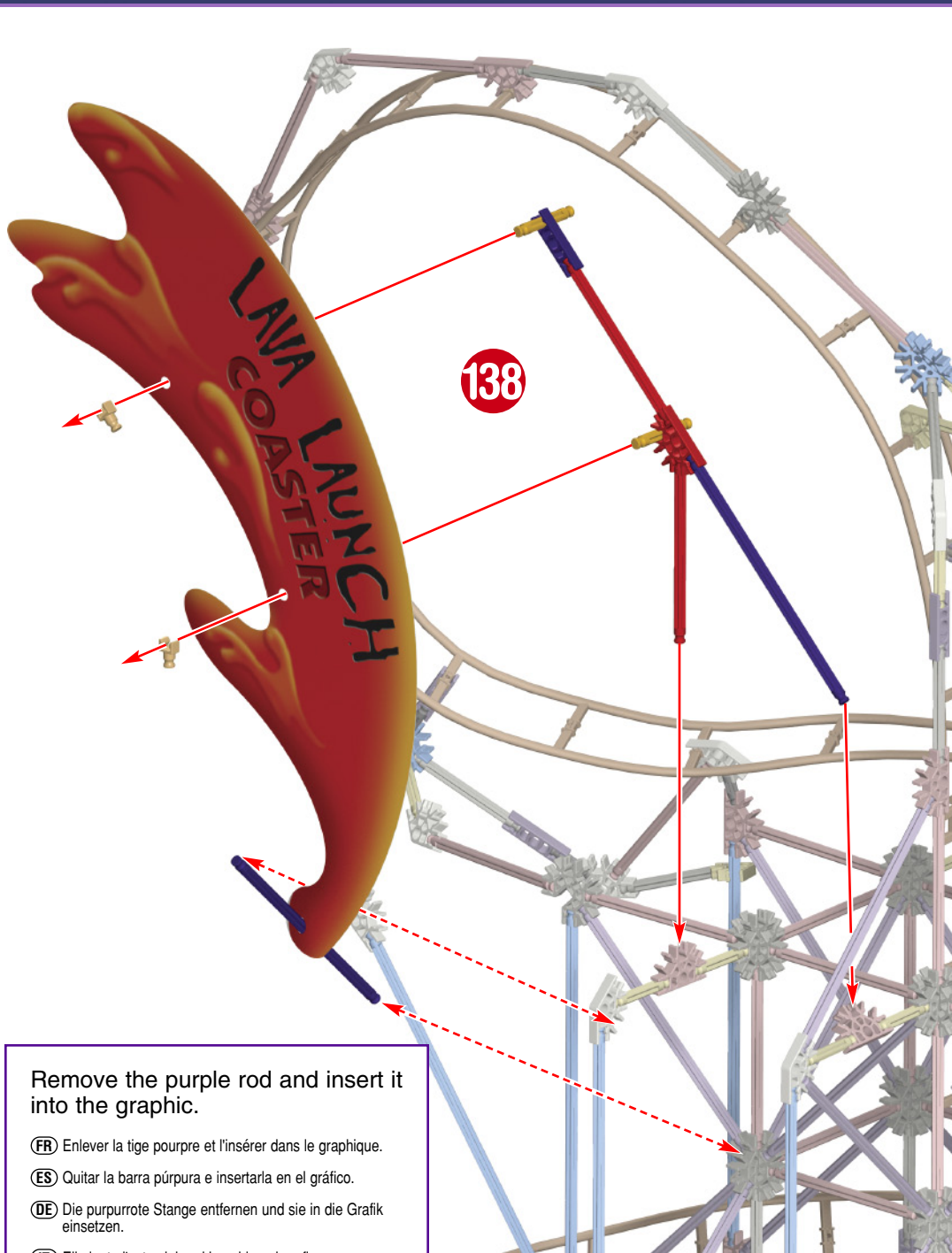

Remove the purple rod and insert it into the graphic.

- (FR)** Enlever la tige pourpre et l'insérer dans le graphique.
- (ES)** Quitar la barra púrpura e insertarla en el gráfico.
- (DE)** Die purpurrote Stange entfernen und sie in die Grafik einsetzen.
- (IT)** Eliminate l'asta viola ed inserirla nel grafico.
- (PT)** Remover a haste roxa e introduzi-la no gráfico
- (NL)** Verwijder de purpere staaf en neem het in grafisch op.

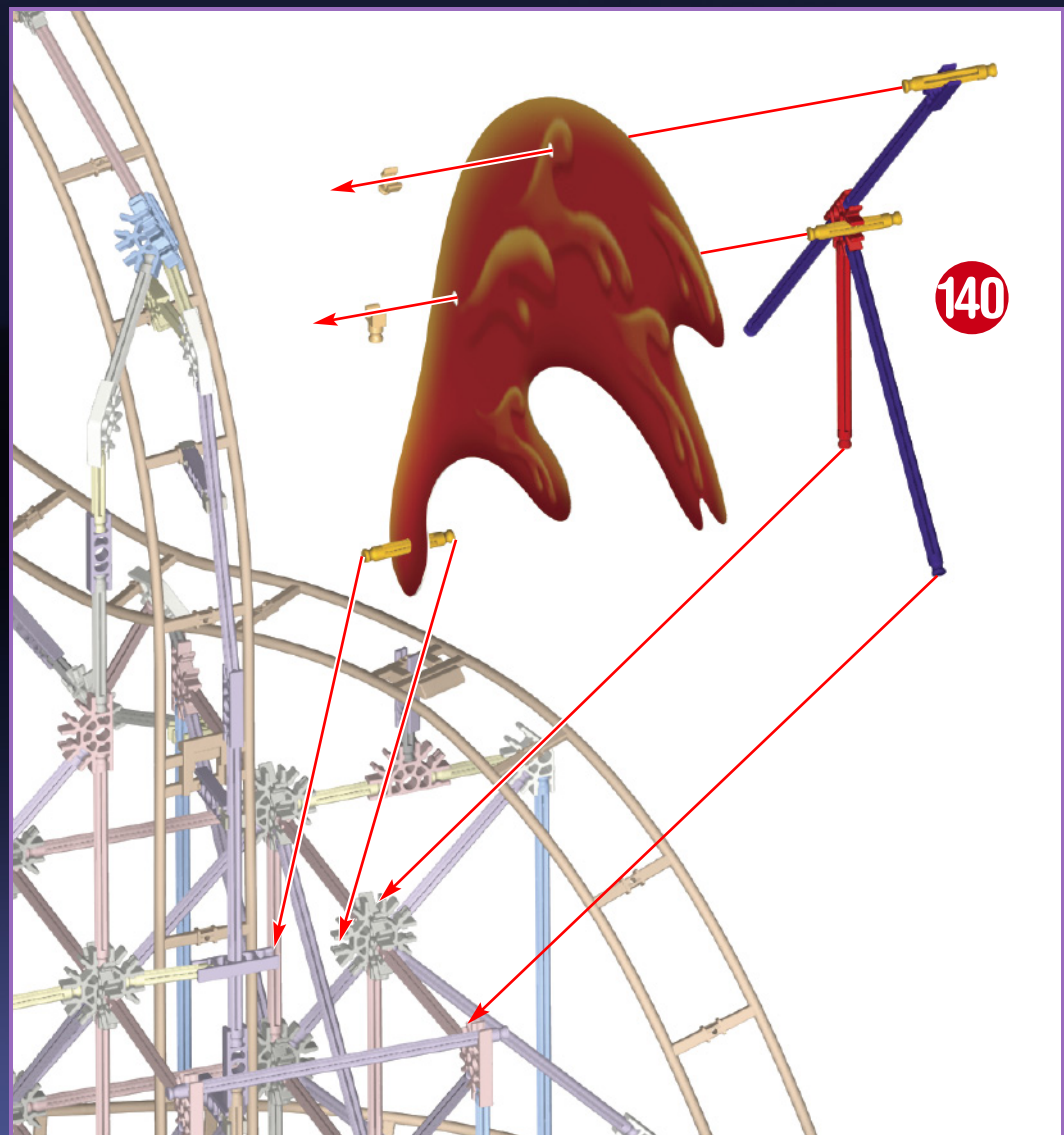
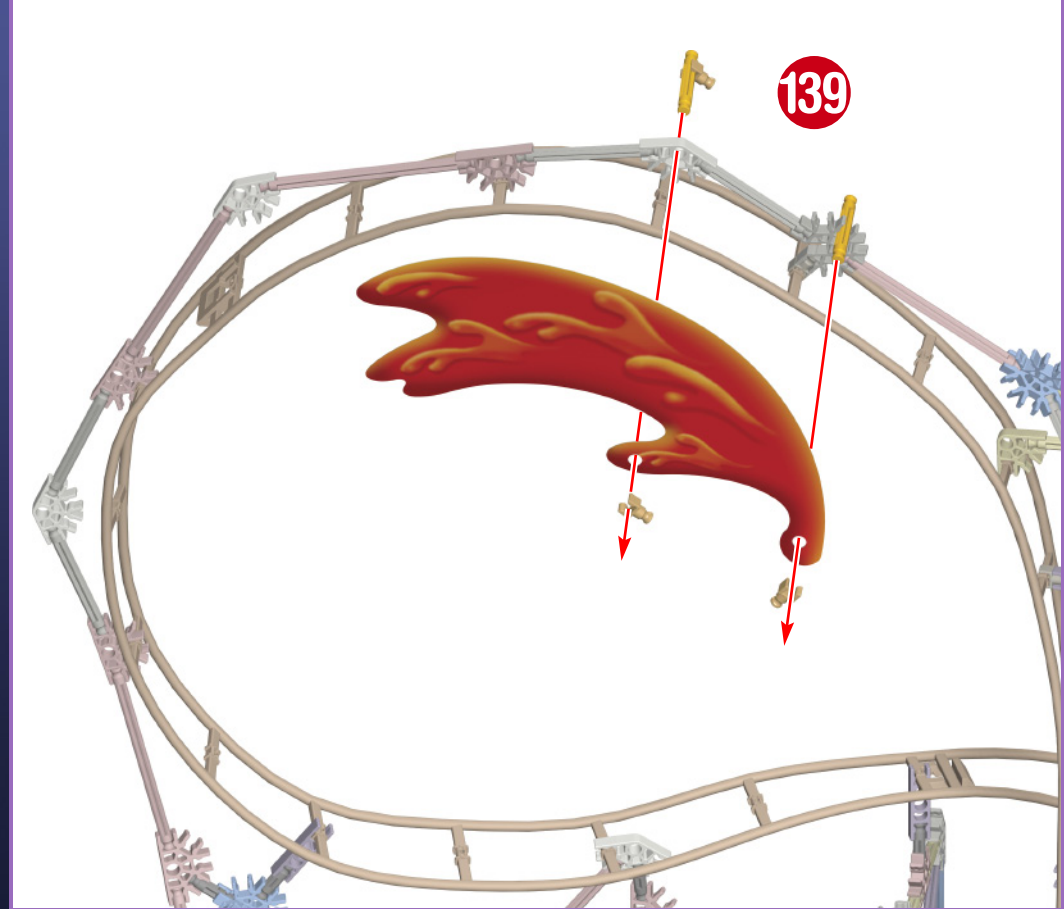

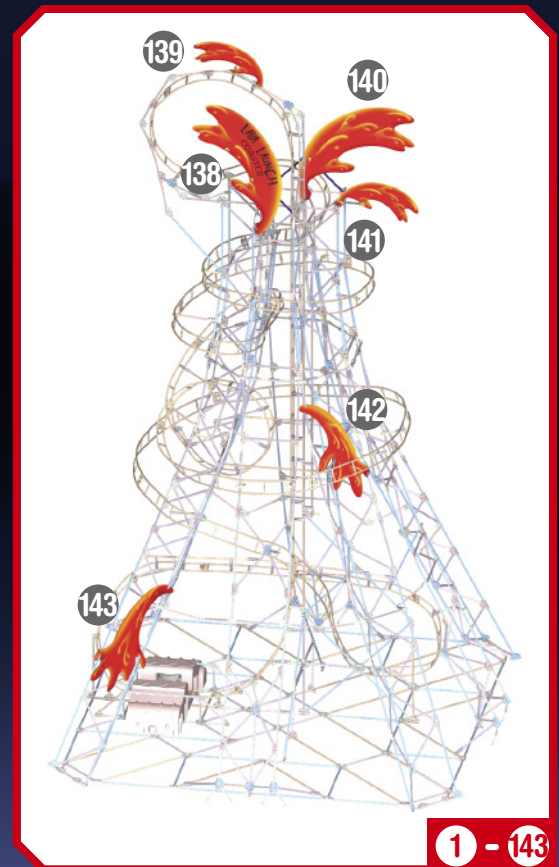
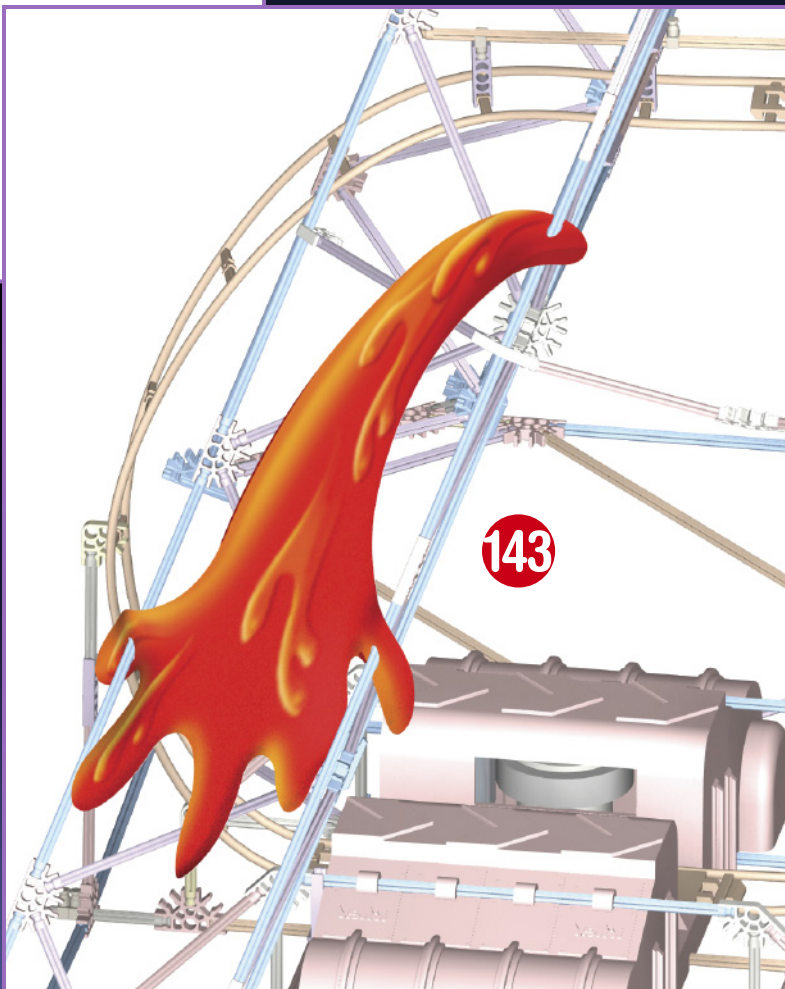
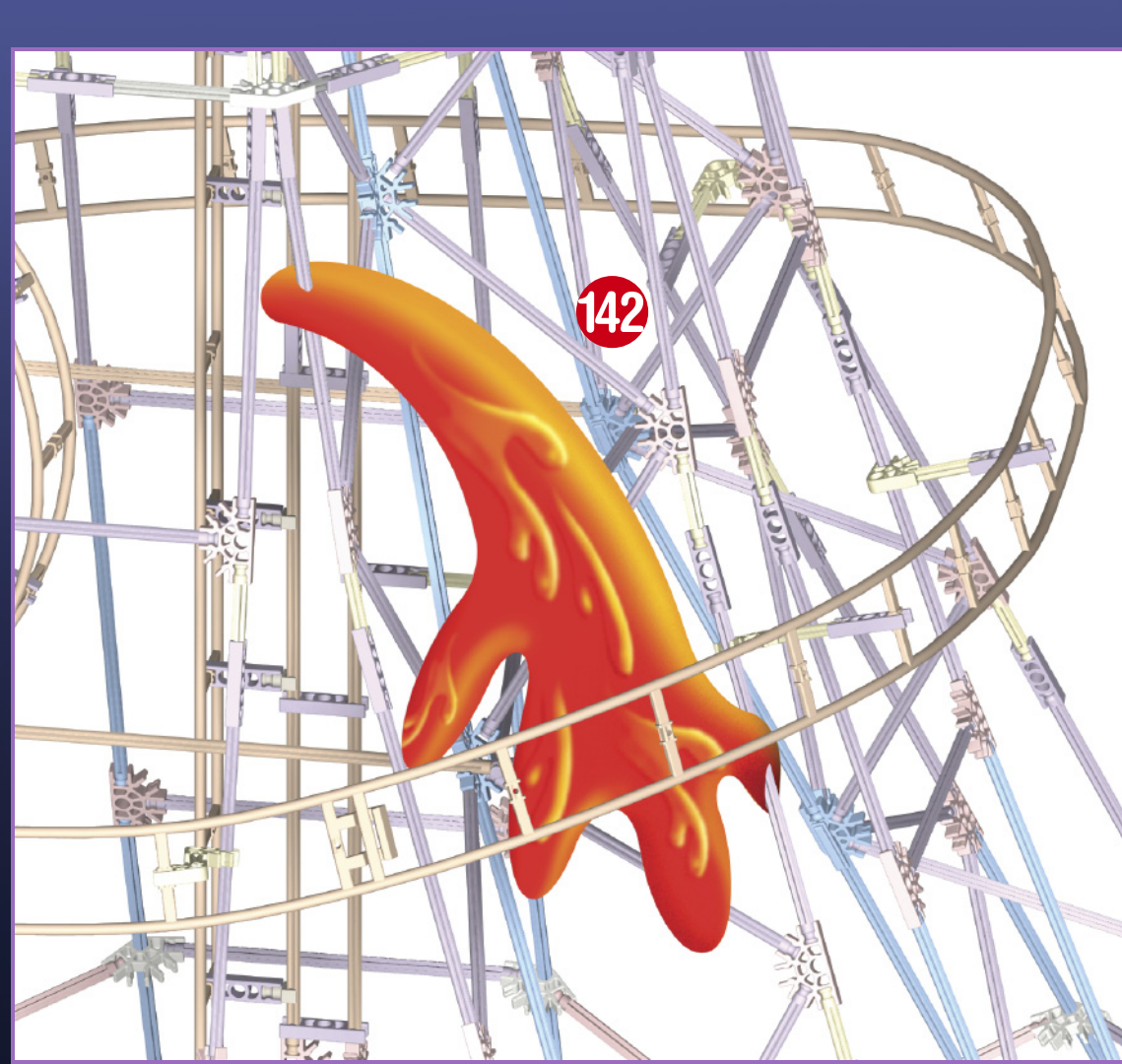
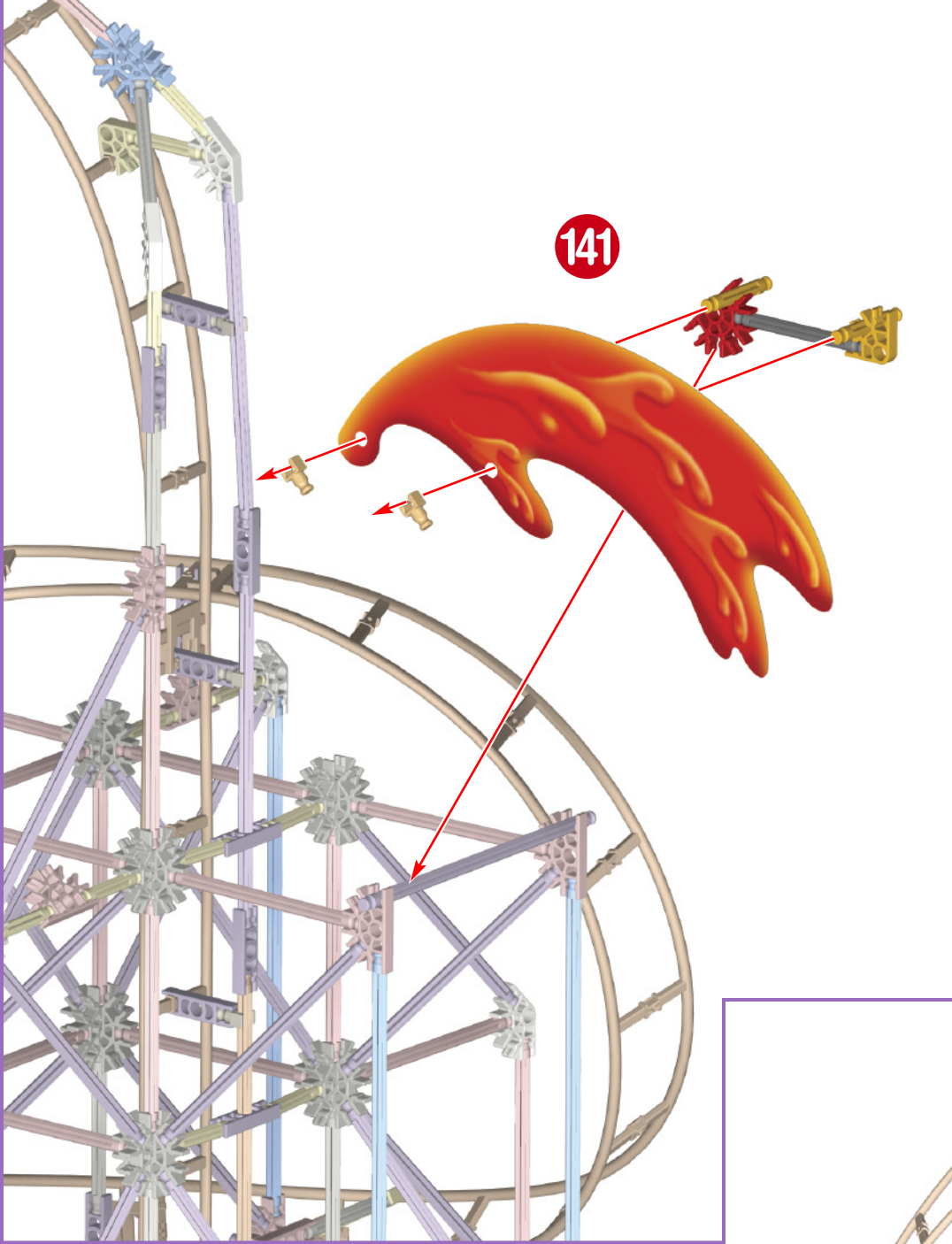

# Attaching Coaster Car

To attach the car, slide onto an open end of the track. If the car gets stuck on the way down, make sure it is not hitting any K'NEX parts.

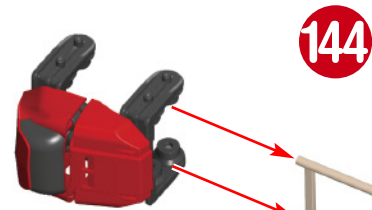

1 - 143

## Tips & Troubleshooting

- The motor is designed for use only in the direction shown.
- Do not let the car fall back into the motor because this may cause damage to the car.
- For best operation, you may want to clean the sides of the car periodically with a damp cloth.

### If the motor is not working properly:

- Check to see if you have fresh batteries and that they are installed correctly.
- If it is still not working, call our Consumer Hotline at 1-800-KID-KNEX (USA and Canada only). See the back cover for other ways to contact K'NEX.

### If a car gets stuck on the track:

- Is the model built correctly?
- Make sure the car is not hitting any K'NEX parts.
- Are the track pieces connected properly?
- Is the car attached to the track correctly?
- Adjust the track to eliminate any flat or little bumpy spots on the track.
- Check to see that the car is not wedged between the motorized wheels.

### Need additional building help?

- Go to the K'NEX web site: [www.knex.com/tips](http://www.knex.com/tips)

Car must travel in the direction shown.



# LAVA LAUNCH COASTER™

1 - 144

## TURBO BOOST COASTER™

Bonus instructions at [www.knex.com/thrill-rides](http://www.knex.com/thrill-rides)

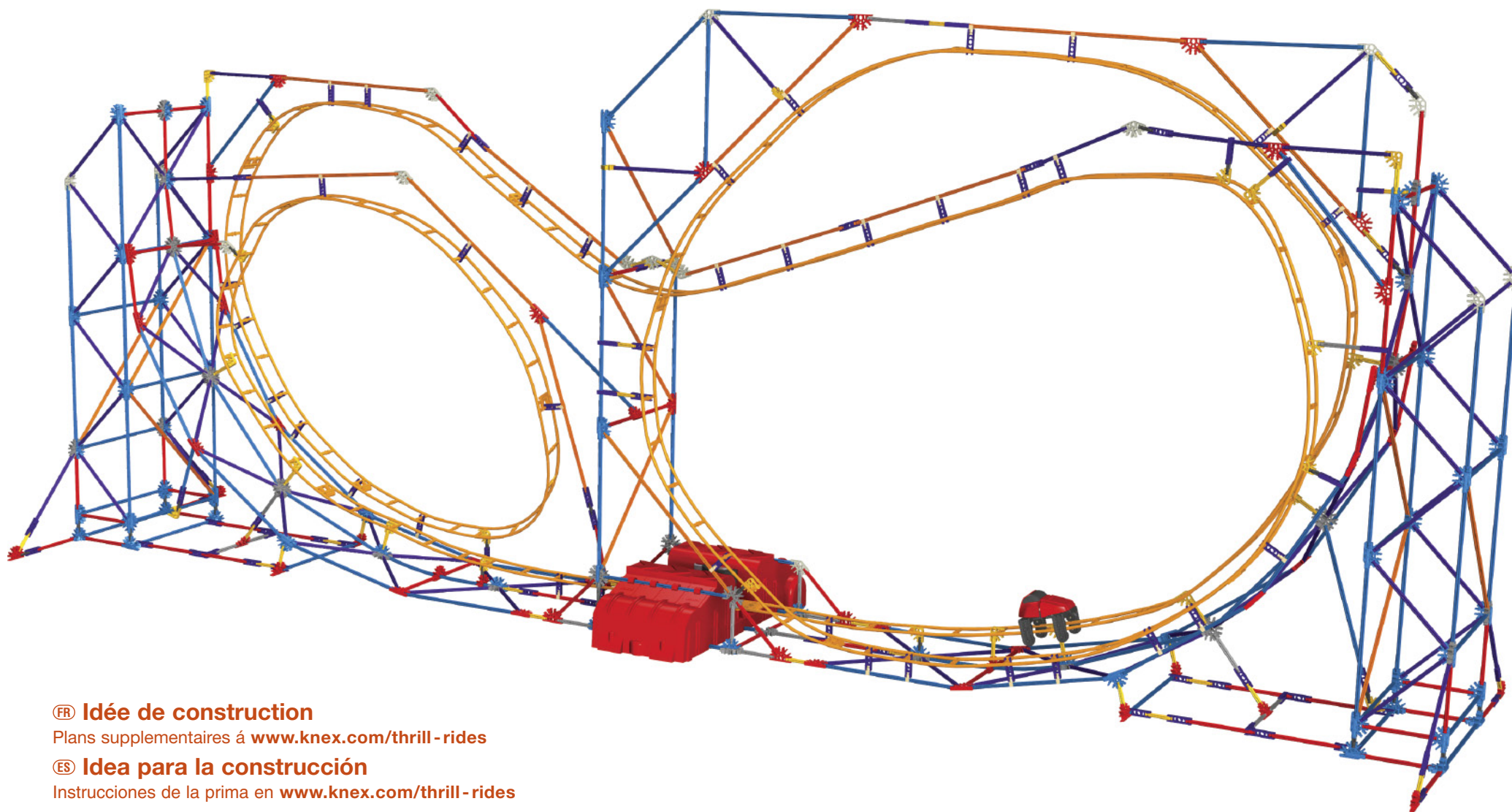

Ⓡ **Idée de construction**

Plans supplémentaires à [www.knex.com/thrill-rides](http://www.knex.com/thrill-rides)

Ⓡ **Idea para la construcción**

Instrucciones de la prima en [www.knex.com/thrill-rides](http://www.knex.com/thrill-rides)

Ⓡ **Bauvorschlag**

Zusätzliche Bauanleitungen bei [www.knex.com/thrill-rides](http://www.knex.com/thrill-rides)

Ⓡ **Idea di costruzione**

Bonus Istruzioni a [www.knex.com/thrill-rides](http://www.knex.com/thrill-rides)

Ⓡ **Ideia de construção**

Instruções do bônus em [www.knex.com/thrill-rides](http://www.knex.com/thrill-rides)

Ⓡ **Idee voor bouwen**

De instructies van de bonus bij [www.knex.com/thrill-rides](http://www.knex.com/thrill-rides)



- Helfen Sie Ihrem Kind beim Bauen mit K'NEX und machen Sie aus diesem Bauprojekt ein Abenteuer mit Spaß und guter Laune für die gesamte Familie.
- Das Zusammenbauen macht Spaß, also nehmen Sie sich Zeit und hetzen Sie nicht!
- Versuche, dein Modell beim Zusammenbauen so zu orientieren, dass es in die gleiche Richtung weist, wie es in den Anleitungen beschrieben und gezeigt wird.
- Die Produkte und Farben unterscheiden sich eventuell von denen auf den Abbildungen.

## Informationen zu den Batterien

### VORSICHT:

- Achte darauf dass die Batterien korrekt eingelegt werden und folge den Anweisungen der Spielzeug- und Batteriefabrikanen.
- Mische keine alten und neuen Batterien oder alkaline Batterien, Standardbatterien (Kohle-Zink) oder wiederaufladbare Batterien (Nickel-Cadmium). Verwende nur Batterien des gleichen Typs oder des empfohlenen äquivalenten Typs.
- Leere oder verbrauchte Batterien aus dem Spielzeug entfernen; darauf achten, dass die Pole der Batterie nicht kurzgeschlossen werden.
- Beim Einlegen der Batterien auf die korrekte Polarität (+/-), wie dargestellt, achten.

### Wichtige Tipps

- Alkaline Batterien werden empfohlen.
- Wiederaufladbare Batterien sind nicht empfohlen.
- Bei Verwendung von wiederaufladbaren Batterien müssen diese aus dem Spielzeug entfernt werden, bevor sie wieder aufgeladen werden; das Wiederaufladen darf nur unter Aufsicht eines Erwachsenen stattfinden.
- Nichtwiederaufladbare Batterien dürfen nicht wieder aufgeladen werden.
- Die Komponenten von Staub freihalten; nicht in Wasser tauchen.
- Zu entsorgende Batterien nicht ins Feuer werfen; sie können auslaufen oder explodieren und Körperverletzungen verursachen.
- Wenn das Spielzeug längere Zeit nicht verwendet werden soll, alle Batterien entfernen.
- In keine der Öffnungen des Motor kleine Stangen einsetzen; sie beschädigen den Motor und können nicht entfernt werden.
- Trage zum Umweltschutz bei und entsorge unser Produkt sowie die Verpackung in verantwortungsvoller Weise. Das Mülltonnen-Symbol bedeutet, dass das Produkt und die Batterien nicht dem Restmüll zugeführt werden dürfen, weil sie Stoffe enthalten, die sich schädigend auf die Umwelt und die Gesundheit auswirken können. Bitte recycle den Artikel bzw. die Batterien und werfe sie in die entsprechenden Recyclingcontainer.

### Anweisungen zum Einlegen und Entfernen der Batterien

- 3 C (Mignon oder LR14) Batterien gemäß Abbildung einlegen.

(Seite 3)

## Grundlegende Bauanleitungen für K'NEX

### Los geht's mit dem Bauen

Um mit dem Bauen deines Modells zu beginnen, suche die Nummer 1 und folge den laufenden Nummern. Jedes Teil hat seine eigene Form und Farbe. Schau dir einfach die Abbildungen an, such die Teile in deinem Bausatz, die so aussehen wie das, was du auf der Abbildung siehst und steck sie ineinander. Versuche, dein Modell beim Zusammenbauen so zu orientieren, dass es in die gleiche Richtung weist, wie es in den Anleitungen beschrieben und gezeigt wird. Blasser Farben weisen darauf hin, dass dieser Streckenabschnitt bereits zusammengebaut ist.

### Motor

Der Pfeil auf dem Motor deutet die Richtung an, in die sich das wagen bewegt. Nach dem Drehen des Motors immer warten, an vor das Auto in Richtung zum Motor einige Sekunden leicht drücken.

### Verbindungsstücke

Blaue und silberfarbene verbindungsstücke haben besonders lange Schlitze. Wie du auf der Abbildung sehen kannst, lassen sie sich ineinander schieben. Achte beim Aneinanderfügen dieser Teile darauf, dass du ein Klickgeräusch hörst. Erst dann sind die Teile fest miteinander verbunden.

### Schienen

Drücke sie so fest, dass sie einhaken. Die einzelnen Schienenstücke müssen immer mit der Oberseite nach oben zeigen, wenn sie miteinander verbunden werden. Druk de koppelstukken goed erin tot ze "klikken". Es kommt in zwei verschiedenen Stilen.

### Teileliste

Bevor du mit dem Bauen anfängst, solltest du prüfen ob die Teile in deinem Bausatz mit denen auf dieser Teileliste übereinstimmen. Falls etwas fehlt, rufe uns an oder schreibe uns (siehe Rückseite). Wir sind für dich da!

(Seite 66)

Om de wagens vast te maken, knijp lichtjes aan het spoor en haak de wielen op het spoor vast. Wanneer wagens vastlopen tijdens de daling: Verzeker je ervan dat de wagen tegen geen K'NEX onderdelen aanloopt.

## Fehlerbehebung:

- Die motor sind ausschließlich zur Anwendung in die angezeigte Richtung bestimmt.
- Das Wagen auf keinen Fall in die motoren zurückfallen lassen, da dies eine Beschädigung des Wagen oder des Schwanzes zur Folge haben kann.
- Um die optimale Funktion des wagen zu gewährleisten, empfiehlt es sich, die Seiten regelmäßig mit einem feuchten Tuch zu reinigen.

### Falls der Motor nicht funktionieren:

- Überprüfe, ob die Batterien voll sind und richtig eingelegt sind.
- Falls es immer noch nicht funktioniert, kannst du innerhalb der USA und Kanadas unsere Hotline anrufen (Tel. 1-800-KID KNEX). Auf der Rückseite dieser Anleitung findest du weitere Möglichkeiten, K'NEX Limited Partnership Group zu kontaktieren.

### Falls die Wagen bei der Abfahrt stecken bleiben:

- Ist das Modell richtig zusammengebaut?
- Überprüfe, ob der Wagen gegen einzelne Bauteile stößt.
- Sind die Schienenstücke richtig miteinander verbunden?
- Sitzt der Wagen richtig auf den Schienen?
- Ändere den Schienenverlauf so, dass die Wagen immer genügend Schwung haben.
- Überprüfen, um zu sehen, dass das Auto nicht zwischen die motorisierten Räder gezwängt wird.

(Seite 67)

Die Wagen müssen in die gezeigte Richtung bewegt werden.

## IT Italiano

(Pagina 2)

## Informazioni importanti per bambini e genitori

**Tenere queste istruzioni a portata di mano. Contengono importanti informazioni di sicurezza.**

**Leggere tutte le avvertenze e le istruzioni prima di iniziare a costruire il modello e di farlo funzionare.**

**AVVERTENZA:** PERICOLO DI SOFFOCAMENTO - Piccole parti. Non adatto a bambini di età inferiore ai 3 anni.

**ATTENZIONE:** Tenere i capelli, le dita, il viso e i vestiti lontani da tutte le parti in movimento.

**ATTENZIONE:** Fare attenzione non rovesciare il modello. Il modello dovrebbe essere collocato su un appartamento ed una superficie dura.

- Condividi l'esperienza di K'NEX con tuo figlio e rendi la costruzione con K'NEX un divertimento per tutta la famiglia.
- Prendi il tempo necessario per divertirti durante il processo di costruzione. Non ti affrettare!
- Orienta il tuo modello nella stessa direzione indicata nelle istruzioni.
- Il prodotto e i colori possono variare.

## Informazioni sulle batterie

### ATTENZIONE:

- Accertarsi di inserire le batterie correttamente e seguire sempre le istruzioni del produttore delle batterie e del giocattolo.
- Non mettere insieme batterie nuove e vecchie o alcaline, standard (carbonio-zinco) e ricaricabili (nichel-cadmio). Usare sempre batterie raccomandate dello stesso tipo o di tipo equivalente.
- Rimuovere sempre batterie quasi scariche o completamente scariche dal prodotto; non causare corto circuito ai terminali di alimentazione.
- Inserire le batterie con la polarità corretta (+/-) come illustrato.

### Consigli importanti

- Si raccomanda l'uso di batterie alcaline.
- Non si raccomanda l'uso di batterie ricaricabili.
- Rimuovere le batterie ricaricabili dal giocattolo prima della carica: devono essere caricate solo sotto la supervisione di un adulto.
- Le batterie non ricaricabili non devono essere ricaricate.
- Mantenere i componenti privi di polvere; non immergere o usare in acqua.
- Non gettare le batterie nel fuoco, poiché potrebbero perdere o esplodere e causare lesioni.
- Rimuovere tutte le batterie se il giocattolo non verrà usato per un lungo periodo di tempo.
- Non inserire aste più corte di 5,1 cm (2 pollici) nei fori del motore, in quanto danneggerebbero il motore e non possono essere rimosse.
- Aiuta l'ambiente eliminando il prodotto e la confezione in modo responsabile. Il simbolo concernente il sechio con le ruote indica che il prodotto e le batterie non possono essere eliminati con la spazzatura domestica in quanto contengono sostanze che possono danneggiare l'ambiente e la salute. Usare i punti di raccolta designati o gli impianti di riciclaggio quando si devono eliminare l'articolo e le batterie.

### Come inserire e rimuovere le batterie

- Inserire 3 batterie C (o LR14) come illustrato.

(Pagina 3)

## Istruzioni di base per costruire con K'NEX

### Comincia a costruire

Per iniziare il modello, cerca il numero 1 e segui i numeri. Ogni pezzo ha una sua forma e un suo colore. Guarda la figura, trova i pezzi corrispondenti nel set e mettili insieme. Cerca di tenere il modello nella stessa direzione della figura e in tal modo sarà più semplice attaccare i pezzi nei posti giusti. I colori spenti ti dicono che questa sezione è già stata costruita. Dovrai collegare la nuova sezione al punto indicato dalla punta della freccia.

### Motore

La macchina andrà nel senso della freccia al cima del motore. Devi sempre aspettare alcuni secondi dopo che accendi il motore, prima di delicatamente dare una spinta alla macchina verso il motore.

### Connettori

È molto importante posizionare i connettori blu e argento in una specifica direzione. Presta molta attenzione alle istruzioni e posiziona i connettori orizzontalmente o verticalmente proprio come illustrato. Spingi con forza fino ad udire un clic.

### Rotaia

Collega sempre la rotaia parte superiore a parte superiore in tutta la costruzione. Premi i connettori saldamente fino a che si fissano con uno scatto. Si è fatto in due forme diverse.

### Elenco delle parti

Prima di cominciare a costruire, accertati di confrontare le parti che sono nel tuo set con l'elenco delle parti qui. Se ne manca una chiamaci o scrivicci usando le informazioni che sono nella retrocopertina. Noi siamo qui per aiutarti!

(Pagina 66)

Per collegare le carrozze, stacca un pezzo di rotaia e quindi infila le ruote della carrozza sulla parte superiore della rotaia. Quindi unisci i pezzi della rotaia. Se le carrozze si arrestano durante la discesa: Controlla che la carrozza non abbia colpito qualche altra parte K'NEX.

## Risoluzione dei problemi:

- Il motore è progettato per uso soltanto nel senso indicato.
- Non lasciare la macchina cadere indietro dentro il motore perché questo può danneggiare la macchina.
- Per l'operazione migliore, potete pulire periodicamente i lati della macchina con un panno umido.

### Se il motore non funzionano:

- Controlla che le batterie siano nuove e che siano installate correttamente.
- Se ancora non dovesse funzionare, chiama il numero di assistenza ai clienti 1-800-KID-KNEX (USA e Canada soltanto). Vedi il retro della scatola per trovare altri modi di contattare K'NEX Limited Partnership Group.

### Se le carrozze si arrestano durante la discesa:

- Il modello è costruito correttamente?
- Controlla che la carrozza non abbia colpito qualche altra parte K'NEX.
- I pezzi della rotaia sono collegati correttamente?
- La carrozza è collegata alla rotaia correttamente?
- Regola la rotaia per eliminare qualsiasi parte piatta sulla stessa.
- Verifica che la macchina non è incuneata fra le rotelle motorizzate.

(Pagina 67)

La macchina deve viaggiare nel senso indicato.

## PT Português

(Página 2)

## Coisas importantes para os Pais e os Miúdos

**Mantenha estas instruções num local de fácil acesso, pois contém informações importantes de segurança.**

**Lê as instruções e advertências antes de começares a construir e a operar o modelo.**

**AVISO:** PERIGO DE SUFOCAÇÃO - Peças pequenas. Não se destina a crianças com menos de 3 anos de idade.

**CUIDADO:** Mantém o cabelo, os dedos, a cara e a roupa afastados de todas as peças móveis.

**CUIDADO:** Tenha cuidado não virar o modelo. O modelo deve ser colocado numa superfície dura plana.

- Compartilhe da experiência K'NEX com os miúdos e faça com que o processo de construção com K'NEX se torne numa aventura entre família.
- Não te precipites para assim poderes desfrutar do processo de construção. Não o faças à pressa!
- Tenta fazer com que o teu modelo esteja virado exactamente na mesma direcção indicada nas instruções.
- Tanto o produto como as respectivas cores podem variar.

## Informações sobre as pilhas

### Cuidado:

- Certifique-se de que introduz as pilhas correctamente e siga sempre as instruções do fabricante da bateria e do brinquedo.
- Não combine pilhas usadas com pilhas novas, pilhas alcalinas, padrão (carbono-zinco) ou pilhas recarregáveis (níquel-cádmio). Deverão ser usadas apenas pilhas do mesmo tipo ou equivalentes ao tipo recomendado.
- Retire sempre as pilhas fracas ou gastas do produto; não provoque um curto-circuito nos terminais de alimentação.
- Introduza as pilhas com a polaridade correcta (+/-), conforme se mostra.

### Conselhos importantes

- Recomenda se o uso de pilhas alcalinas.
- Não se recomenda o uso de pilhas recarregáveis.
- Retire as pilhas recarregáveis do brinquedo antes de as carregar; estas pilhas devem ser recarregadas apenas sob vigilância de adultos.
- As pilhas não recarregáveis não devem ser carregadas.
- Mantenha os componentes livres de poeiras; não mergulhe em água nem use água.
- Não elimine as pilhas queimando-as; estas podem apresentar fugas ou explodir causando lesões.
- Retire todas as pilhas do brinquedo se não tencionar usá-lo durante um longo período de tempo.
- Não coloque varetas de tamanho inferior a 5,1 cm (2 pol.) em nenhuma abertura do motor; as varetas causarão danos no motor e não podem ser removidas.
- Ajude o ambiente eliminando o seu produto e a embalagem vazia responsabilmente. A imagem do contentor do lixo com rodinhas indica que o produto e as pilhas não devem ser eliminados juntamente com os resíduos domésticos pois contêm substâncias que podem provocar efeitos nocivos no ambiente e na saúde. Por favor use os pontos de recolha designados ou as instalações de reciclagem quando necessitar de eliminar o produto ou as pilhas.

### Como inserir e remover as pilhas

- Introduza 3 pilhas C (ou LR14), conforme se mostra.

(Página 3)

## Pontos básicos para a construção K’NEX

### Inicia a construção

Para começar o teu modelo, procura o **1** e segue os números. Cada peça tem a sua própria forma definida e cor. Basta simplesmente olhares para a ilustração, procurar as peças do teu jogo correspondentes às que estás a ver e, em seguida, conectar umas nas outras. Enquanto estás a montar as peças, tenta manter o teu modelo na mesma direcção, conforme mostrado na ilustração, para assim ligares as peças correctamente. As cores desbotadas indicam que esta secção já está montada. Passarás então a fazer a conexão da nova secção no local indicado pelas setas.

### Motor

O carro irá no sentido da seta sobre o motor. Esperar sempre alguns segundos após ter girado o motor sobre antes delicadamente de empurrar o carro para o motor.

### Conectores

É muito importante que posiciones os conectores azuis e cor de prateados numa direcção específica. Presta muita atenção às instruções e coloca estes conectores horizontal ou verticalmente, exactamente conforme se mostra nas ilustrações. Junta as partes simultaneamente e com firmeza até ouvires um "estalido".

### Pista

Liga sempre a face superior da Pista à face superior durante a montagem.

Faz avançar os conectores firmemente até “encaixarem” com um estalido. É feito em duas formas diferentes.

### Lista de peças

Antes de iniciares a construção, certifica-te de que comparas as peças do teu conjunto com a lista das peças aqui. Se faltar alguma peça telefona ou escreve-nos usando as informações indicadas na contracapa. Estamos aqui para te ajudar!

(Página 66)

Para prenderes as Carruagens, desliga uma peça da Pista e, seguidamente, enfia as rodas da Carruagem sobre a face superior da Pista. Depois junta as peças da Pista umas às outras. Se as Carruagens ficarem encravadas na descida: Assegura-te de que a Carruagem não está a chocar contra outras peças K’NEX.

## Resolução de Problemas:

- O motor é projetado para o uso somente no sentido mostrado.
- Não deixar o carro cair de novo no motor porque isto pode causar dano ao carro.
- Para a melhor operação, você pode querer limpar periodicamente os lados do carro com um pano úmido.

### Se o Motor ou o Módulo de Som não funcionar:

- Verifica se as pilhas são novas e se estão instaladas correctamente.
- Caso continuem sem funcionar, contacta a Linha Directa de Atendimento ao Consumidor através do número 1-800-KID-KNEX (apenas nos EUA e no Canadá). Consulta a contra capa para mais informações sobre como contactares a K’NEX Limited Partnership Group.

### Se as Carruagens ficarem encravadas na descida:

- O modelo foi construído correctamente?
- Assegura-te de que a Carruagem não está a chocar contra outras peças K’NEX.
- As peças da Pista estão ligadas correctamente?
- A Carruagem está presa à Pista correctamente?
- Ajusta a Pista para eliminares qualquer ponto plano na Pista.
- Verific para ver que o carro não está firmado entre as rodas motorizadas.

(Página 67)

O carro deve viajar no sentido mostrado.

## 🇳🇱 Nederlands

(Bladzijde 2)

## Belangrijke gegevens voor ouders en kinderen

**Bewaar deze aanwijzingen op een gemakkelijk bereikbare plaats. Ze bevatten belangrijke veiligheidsgegevens.**

**Gelieve alle waarschuwingen en aanwijzingen te lezen vóór je het model begint op te bouwen en te gebruiken.**

**WAARSCHUWING:** VERSTIKKINGSGEVAAR - Kleine onderdelen. Niet geschikt voor kinderen onder 3 jaar.

**OPGEPAST:** Hou het haar, de vingers, het gezicht en kledij verwijderd van alle bewegende onderdelen.

**OPGEPAST:** Wees voorzichtig om het model over niet te tippen. Het model zou moeten geplaatst worden op een flat en kom hard boven.

- Niet trachten iets te lanceren dat niet de wagen is.
- Het spoor niet versperren met objecten of met een deel van je lichaam.
- Deel de K’NEX ondervinding met je kind en maak van het bouwen met K’NEX een aangenaam familieavontuur.
- Neem je tijd tijdens het bouwen en monteren. Spoed je niet!
- Tracht je model in dezelfde richting te plaatsen als de aanwijzingen terwijl je bouwt en monteert.
- Produkt en kleuren kunnen afwijken.

## Batterijgegevens

### OPGEPAST:

- Verzeker je ervan dat de batterijen er op de juiste manier in te steken en volg steeds de aanduidingen van de speelgoed- en batterijenfabrikanten.
- Meng geen oude en nieuwe batterijen of alkalische, gewone (koolstof-zink) of herlaadbbaarse (nikkel-cadmium) batterijen met mekaar. Uitsluitend batterijen van dezelfde of van een aanbevolen equivalente soort dienen gebruikt te worden.
- Verwijder steeds uitgeputte of ontladen batterijen uit het produkt; veroorzaak geen kortsluiting van de voedingspolen.
- Steek de batterijen erin volgens de juiste polariteit (+/-) zoals afgebeeld.

### Belangrijke tips

- Alkalische batterijen worden aanbevolen.
- Herlaadbbaare batterijen worden niet aanbevolen.
- Verwijder herlaadbbaare batterijen uit het speelgoed alvorens ze te herladen; ze moeten slechts herladen worden onder het toezicht van een volwassene.
- Niet-herlaadbbaare batterijen mogen niet herladen worden.
- Bescherm onderdelen tegen stof; dompel ze niet of gebruik ze niet in water.
- Werp de batterijen niet in het vuur; ze zouden kunnen lekken of ontploffen en verwondingen veroorzaken.

- Verwijder alle batterijen wanneer het speelgoed gedurende lange tijd niet gebruikt zal worden.
- Plaats staafjes in de openingen van het motor, zij zouden de motor beschadigen en kunnen niet worden verwijderd.
- Help de omgeving door uw product en verpakking verantwoordelijk weg te werpen. Het symbol met de vuilnisbak op wieltjes duidt aan dat het product en de batterijen niet mogen weggeworpen worden in huishoudvuil vermits ze stoffen bevatten die de omgeving en de gezondheid kunnen schaden. Gelieve de aangeduide verzamelpunten of recyclageinstallaties te gebruiken wanneer u zich wil ontdoen van dit artikel of deze batterijen.

### Insteken en verwijderen van batterijen

- Steek er 3 C (of LR14) batterijen erin zoals afgebeeld.

(Bladzijde 3)

## Basisstappen voor K’NEX bouwen

### Begin te bouwen

Om met je model te beginnen, vind eerst het nummer **1** en volg de nummers.

Elk stuk heeft zijn eigen vorm en kleur. Kijk gewoonweg naar de afbeeldingen, vind de overeenstemmende stukken terug in je geheel en maak ze aan mekaar vast.

Tracht je model in dezelfde richting te plaatsen als de aanwijzingen terwijl je bouwt en monteert. De vervaagde kleuren duiden aan dat dit deel reeds is opgebouwd. Gelieve het nieuwe deel vast te koppelen op de plaats aangeduid door de pijlen.

### Motor

De wagen rijdt in de richting van de pijl op de motor. Wacht altijd een paar seconden na het aanzetten van de motor vóór zacht het duwen van de auto naar de motor.

### Koppelstukken

Er zijn blauwe en zilveren koppelstukken met speciale lange gleuven. Ze schuiven in mekaar zoals je kunt zien op de afbeeldingen. Duw deze onderdelen in mekaar tot je een “klik” hoort.

### Spoortips

Maak steeds de bovenkant van het spoor vast aan de bovenkant tijdens de opbouw. Druk de koppelstukken goed erin tot ze “klikken”. Het is gemaakt in twee verschillende vormen.

### Onderdelenlijst

Voor je begint te bouwen, vergewis je ervan de onderdelen in je geheel na te gaan met de onderdelenlijst hier. Wanneer iets ontbreekt, bel ons op of schrijf ons door gebruik te maken van de informatie op het achterblad. We staan er om je te helpen !

(Bladzijde 66)

Om de wagens vast te maken, knijp lichtjes aan het spoor en haak de wielen op het spoor vast. Wanneer wagens vastlopen tijdens de daling: Verzeker je ervan dat de wagen tegen geen K’NEX onderdelen aanloopt.

## Oplossen van problemen:

- De motor zijn ontworpen voor uitsluitend gebruik in de aangeduide richting.
- Laat de wagen niet achteruit op de motor botsen want anders zou de wagen of de staart kunnen beschadigd worden.
- Om de beste werking te bekomen, kuis regelmatig de kanten van de wagen met een vochtig doek.

### Wanneer de motor- of klankmodule niet werkt:

- Kijk na dat je nieuwe batterijen hebt en dat ze er behoorlijk zijn aangebracht.
- Werkt het nog steeds niet, bel dan de Klantendienst Hotline op aan het nummer 1-800-KID-KNEX (uitsluitend in de VS en Canada). Kijk naar het achterblad voor andere manieren om contact op te nemen met K’NEX Limited Partnership Group.

### Wanneer wagens vastlopen tijdens de daling:

- Is het model behoorlijk opgebouwd?
- Verzeker je ervan dat de wagen tegen geen K’NEX onderdelen aanloopt.
- Zijn de spoorstukken behoorlijk verbonden?
- Is de wagen behoorlijk aan het spoor verbonden?
- Ajusteer het spoor om platte stukken op het spoor te verwijderen.
- Controle om te zien dat de auto niet vastgeklemd tussen de gemotoriseerde wielen is.

(Bladzijde 67)

De wagen moet zich verplaatsen in de aangeduide richting.

# KNEX.COM

## Look For These Other Great K'NEX Building Sets!™

Sold separately.  
Vendus séparément.  
Se venden por separado.  
Separat erhältlich.  
Venduti separatamente.  
Vendidos separadamente.  
Afzonderlijk verkocht.



COLLECT ALL  
Collectionnez  
Les **4**

## COLLECT & BUILD™



K'NEX Customer Service; Call 1-800-KID-KNEX (USA/CAN only);  
Write to email@knex.com; Visit www.knex.com  
For Customer Service outside USA/CAN contact your local distributor  
at: <http://www.knex.com/distributors>  
(FR) Le Service clients hors d'USA/CAN, s'il vous plait contacter le  
distributeur local. L'information à <http://www.knex.com/distributors>  
(AZ) (NZ) (UK) (DE) (NL) (BE) (CH) (CL) (PE) <http://www.knex.com/distributors>  
(UK) TOMY Careline, PO Box 20, Totton, Hants, SO40 3YF; Tel 023 8066 2600  
(FR) ALLO TOMY SAV, Parc d'affaires international, 74166 ARCHAMPS  
Tél 0 820 013 013  
(UK) (FR) (DE) (NL) <http://www.tomy.eu>

Product & colors may vary. Standard K'NEX parts made in the USA. K'NEX and Imagine, Build, Play are  
registered trademarks of K'NEX Limited Partnership Group. Manufactured under U.S. Patents/Fabriqu  
é sous brevets américains/Fabricado bajo patentes de EE.UU. 5,061,219; 5,199,919; 5,350,331; 5,137,486;  
D393,417. Other U.S. and foreign patents pending. Autres brevets américains et étrangers en instance.  
Otras patentes de EE.UU. y países extranjeros pendientes.  
(FR) Produits et couleurs peuvent varier. Pièces K'NEX courantes fabriquées aux États-Unis. K'NEX et  
Imagine, Build, Play sont des marques déposées de K'NEX Limited Partnership Group. Autres brevets  
américains et étrangers en instance.  
(ES) El producto y los colores pueden variar. Piezas estándar de K'NEX hechas en EE.UU. K'NEX y  
Imagine, Build, Play son marcas registradas de K'NEX Limited Partnership Group. Otras patentes de  
EE.UU. y países extranjeros pendientes.

©2009 K'NEX Limited  
Partnership Group  
P.O. Box 700  
Hatfield, PA 19440-0700



150050.11-V1-03/09