

K'NEX®

Building Worlds Kids Love®

INFINITE JOURNEY

MONTAÑA RUSA

SET DE CONSTRUCCIÓN

INFINITE JOURNEY

MONTANHA RUSSA

SET DE CONSTRUÇÃO

INFINITE JOURNEY

ROLLER COASTER

BUILDING SET

VOYAGE INFINI

MONTAGNES RUSSES

JEU DE CONSTRUCTION

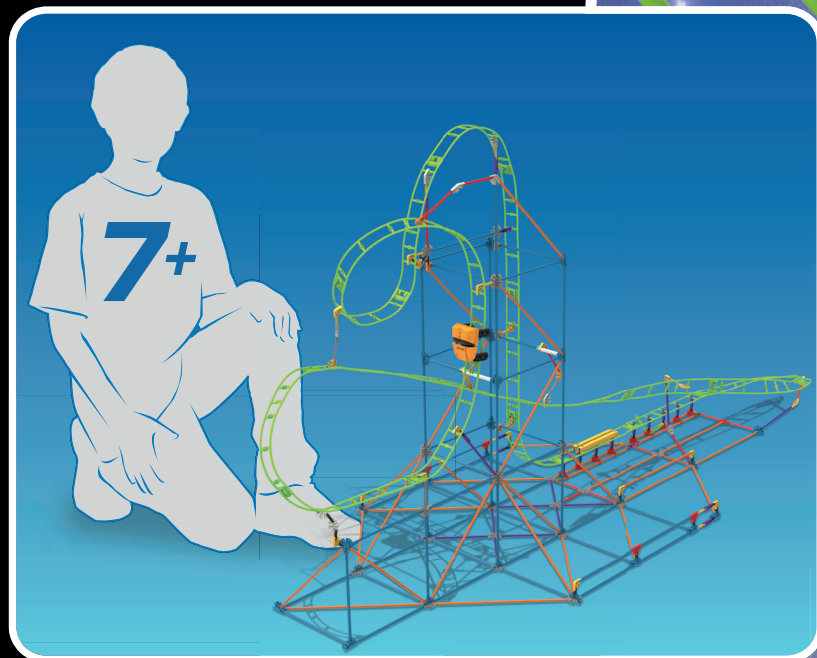

**CON LANZADOR
PROPULSOR
COM LANÇADOR
SLINGSHOT LAUNCHER
PROPULSEUR LANCE-PIERRE**

Mantener esta información para futuras referencias

Información importante para Padres y Niños



ADVERTENCIA: No conveniente para niños menores de 3 años. Piezas pequeñas. Peligro de atragantamiento.

¡ATENCIÓN!: Mantener las manos, la cara, el pelo y la ropa fuera del alcance de las partes móviles.

¡ATENCIÓN!: Mantener la estructura montada encima de una superficie plana y rígida.

PRECAUCIÓN: Si el cabello del niño entra en contacto con las partes en movimiento del juguete, puede quedar enredado.

- No obstruyas la pista con objetos o cualquier parte de tu cuerpo.
- Compartan la experiencia K'NEX con su niño y hagan que la construcción con K'NEX sea una divertida aventura de toda la familia.
- Dedica tiempo a disfrutar el proceso de construcción. ¡No te apresures!
- Mientras construyes, trata de colocar tu modelo en la misma dirección que se muestra en las instrucciones.
- El producto y los colores pueden variar.

PRECAUCIÓN: Las gomas pueden causar daños si se sueltan con fuerza, se rompen o se pierde su control. Al construir los modelos que se muestran en las instrucciones, sujetar bien la goma y no estirarla demasiado. Las gomas deben usarse únicamente como se indica en las instrucciones. NO USAR GOMAS QUE ESTÉN DESGASTADAS NI ASGADAS.

PRECAUCIÓN: Mantenga las gomas elásticas alejadas de la cara y los ojos.

Para actualizar las instrucciones

visita **KNEX.COM**

Mantener esta información importante para referencia futura

Coisas importantes para os Pais e os Miúdos



¡ATENÇÃO!: Não recomendado para crianças menores de 3 anos. Pequenas partes. Risco de asfixia.

¡ATENÇÃO!: Mantém o cabelo, os dedos, a cara e a roupa afastados de todas as peças móveis.

¡ATENÇÃO!: O cabelo da criança pode ficar emaranhado se entrar em contacto com as peças móveis do brinquedo.

¡ATENÇÃO!: Mantém a estrutura colocado sobre uma superfície plana e dura.

- Não obstruir a trilha com objetos ou qualquer parte de seu corpo.
- Compartilhe da experiência K'NEX com os miúdos e faça com que o processo de construção com K'NEX se torne numa aventura entre família.
- Não te precipites para assim poderes desfrutar do processo de construção. Não o faça à pressa!
- Tenta fazer com que o teu modelo esteja virado exactamente na mesma direcção indicada nas instruções.
- Tanto o produto como as respectivas cores podem variar.

CUIDADO: As borrachas poderão causar ferimentos ao serem esticadas, ao quebrarem ou ao perderem controlo. Ao montar os modelos mostrados nas instruções, segure bem a borracha e não a estique demasiado. Utilize as borrachas apenas da forma exemplificada nestas instruções. NÃO UTILIZE BORRACHAS CORROÍDAS OU QUEBRADAS.

CUIDADO: Mantenha as faixas de borracha longe da cara e dos olhos.

Entre em **KNEX.COM para ver actualizações e instruções**

Keep this important information for future reference

Important Stuff for Parents and Kids



WARNING: CHOKING HAZARD - Small parts. Not for children under 3 years.

CAUTION: Keep hands, face, hair and clothing away from all moving parts.

CAUTION: Be careful not to tip the model over. Model should be placed on a flat and hard surface.

- Do not obstruct track with objects or any part of your body.
- Share the K'NEX experience with your child and make building with K'NEX a family fun adventure.
- Take your time to enjoy the building process. Don't rush!
- While you're building make sure you face your model in the same direction as the pictures show in the instructions.
- Product and colors may vary.

CAUTION: Rubber Bands can cause injury from snap-back, breaking, or loss of control. While assembling models shown in instructions, hold rubber band tightly, and do not overstretch. Use Rubber Bands only as shown in these instructions. DO NOT USE FRAYED OR TORN RUBBER BANDS.

CAUTION: Keep Rubber Bands away from face and eyes.

Go to [KNEX.COM](https://www.knex.com) for instruction updates

Gardez précieusement cette notice pour vous y référer ultérieurement

Informations Importantes pour les Parents et les Enfants



ATTENTION : RISQUE D'ÉTOUFFEMENT - Pièces de petite taille. Ne convient pas aux enfants de moins de 3 ans.

ATTENTION : Garde les cheveux, les doigts, la figure et les vêtements à l'écart de toutes les pièces mobiles.

ATTENTION : Faire attention de ne pas renverser le modèle. Le modèle devrait être placé sur une surface plate et dure.

- Ne pas bloquer les rails avec des objets ou la corps.
- Partage l'expérience K'NEX avec ton enfant et fais du montage K'NEX un agréable projet de famille.
- Prends ton temps lors du montage. Ne te presse pas.
- Essaie de situer ton modèle dans le même sens que les instructions durant le montage.
- Le produit et les couleurs peuvent varier.

ATTENTION : Les élastiques peuvent causer des blessures en claquant, en se brisant ou quand on les manipule imprudemment. Tenez fermement les élastiques lors de l'assemblage du modèle en veillant à ne pas trop les tendre. Utilisez les élastiques que selon les instructions comme indique. N'UTILISEZ PAS D'ÉLASTIQUES DISTENDUS OU ABIMÉS.

ATTENTION : Tenez les élastiques à l'écart du visage et des yeux.

Allez [KNEX.COM](https://www.knex.com) à pour les mises à jour d'instruction

Empieza a construir

Para comenzar tu modelo, busca el **1** y sigue los números. Cada pieza tiene su propia forma y color. Simplemente mira los dibujos, busca las piezas correspondientes en tu juego y después conéctalas. Mientras construyes, trata de colocar tu modelo en la misma dirección que se muestra en las instrucciones. Los colores desteñidos muestran que esta sección ya está construida. Conecta las nuevas secciones en los lugares señalados por las flechas. Las nuevas piezas que agregues estarán en colores vivos.

Inicia a construção

Para começar o teu modelo, procura o **1** e segue os números. Cada peça tem a sua própria forma definida e cor. Basta simplesmente olhares para a ilustração, procurar as peças do teu jogo correspondentes às que estás a ver e, em seguida, conectar umas nas outras. Enquanto estás a montar as peças, tenta manter o teu modelo na mesma direcção, conforme mostrado na ilustração, para assim ligares as peças correctamente. As cores desbotadas indicam que esta secção já está montada. Passarás então a fazer a conexão da nova secção no local indicado pelas setas.

Start Building

To begin your model, find the **1** and follow the numbers. Each piece has its own shape and color. Just look at the pictures, find the pieces in your set that match and then connect them together. Try to face your model in the same direction as the instructions while you build. The arrows show you where the parts connect, but not all connections points have arrows. Faded colors show you this section is already built.

Démarre ta Construction

Pour commencer le modèle, cherche l'étape numéro **1** et suis les numéros dans l'ordre. Chaque pièce a sa propre forme et sa propre couleur. Regarde les illustrations, trouve les pièces qui y correspondent et les assemble-les. Pour te faciliter la tâche, oriente le modèle dans le même sens que les instructions. Les flèches indiquent où les pièces s'assemblent, mais les points de raccordement n'ont pas tous des flèches. Les pièces ayant une couleur estompée sont celles déjà assemblées.

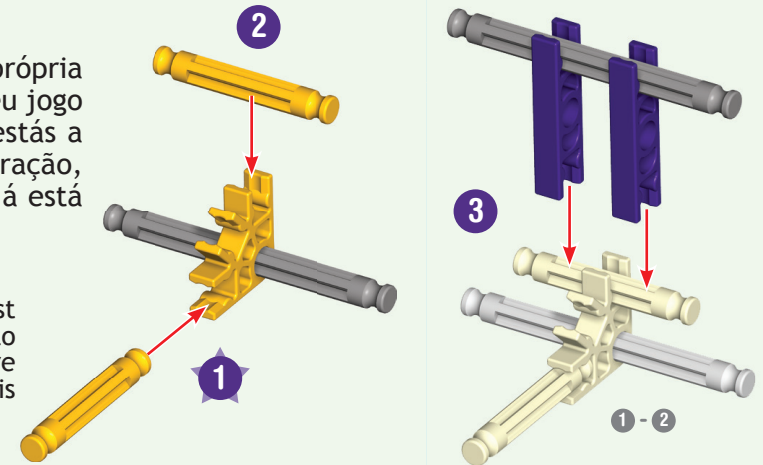

Conectores

Hay conectores con ranuras largas especiales. Se enganchan deslizándose como ves en los dibujos. Conecta estas piezas empujándolas hasta que oigas “clic”.

Conectores É muito importante que posiciones os conectores numa direcção específica. Presta muita atenção às instruções e coloca estes conectores horizontal ou verticalmente, exactamente conforme se mostra nas ilustrações. Junta as partes simultaneamente e com firmeza até ouvires um “estalido”.

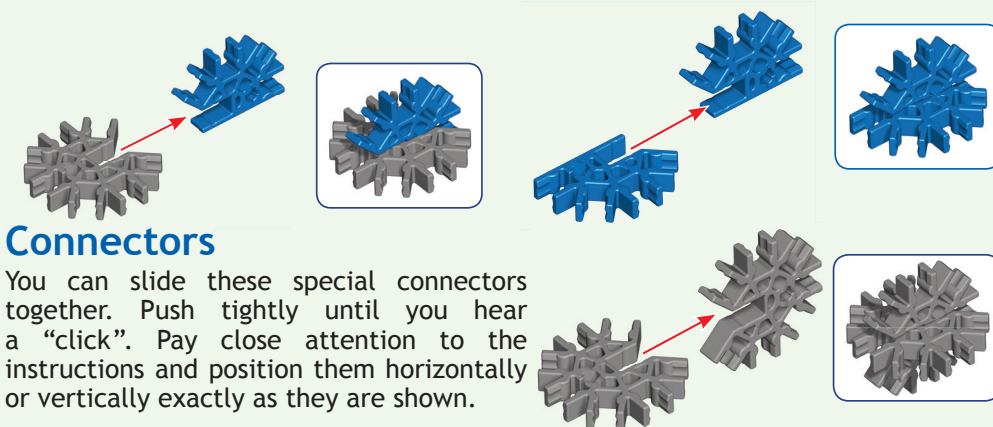

Connectors

You can slide these special connectors together. Push tightly until you hear a “click”. Pay close attention to the instructions and position them horizontally or vertically exactly as they are shown.

Connecteurs

Tu peux assembler ces connecteurs spéciaux en les faisant glisser l'un dans l'autre. Pousse fort jusqu'à entendre un « clic ». Lis attentivement les instructions et positionne-les horizontalement ou verticalement, en suivant exactement les illustrations.

Espaciadores

Hay lugares en tu modelo donde tendrás que agregar espaciadores azules y plateados. Cerciórate de usar el color correcto y cuéntalos con cuidado.

Espaçadores

Existirão certos pontos no teu modelo que necessitam a colocação de espaçadores azuis e prateados. Assegura-te que os contas cuidadosamente.

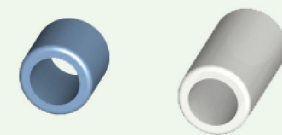

Spacers

There are places in your model where you need to add blue and silver spacers. Be sure to use the correct number of spacers shown in the instructions.

Séparateurs

Il y a des endroits sur le modèle où des séparateurs sont nécessaires. Assure-toi d'utiliser la bonne couleur et le nombre de séparateurs, comme indiqué sur les instructions.

Lista de Piezas

Antes de empezar con la construcción, asegúrate de comparar las piezas en tu conjunto con la lista de las piezas aquí. Si faltan algunas, llámanos o escríbenos siguiendo las instrucciones en la página trasera. Estamos aquí para ayudarte.

Lista de Peças

Antes de iniciars a construção, certifica-te de que comparas as peças do teu conjunto com a lista das peças aqui. Se faltar alguma peça telefona ou escreve-nos usando as informações indicadas na contracapa. Estamos aqui para te ajudar!

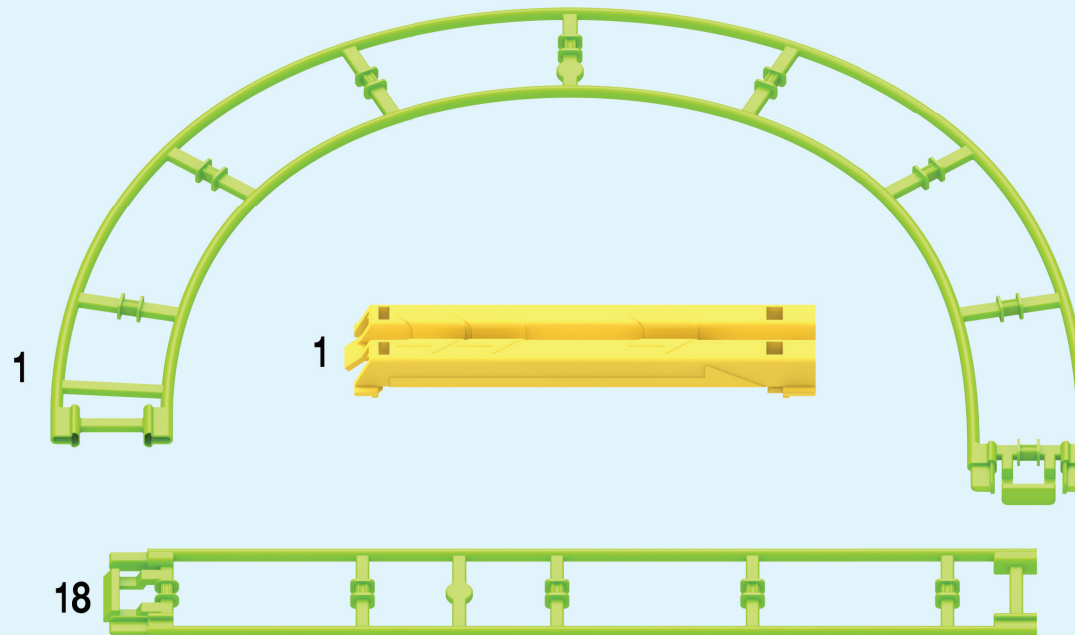
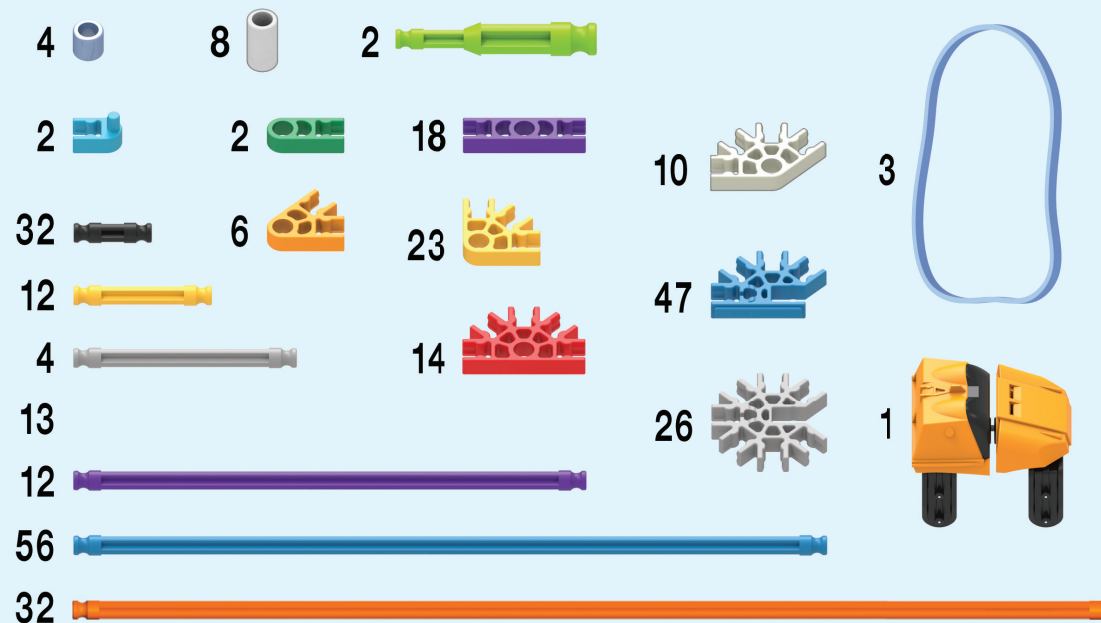

Parts List

Before you start building, be sure to compare the parts in your set with the parts list here. If anything is missing, call or write to us using the information on the back cover. We are here to help you!

Liste des Pièces





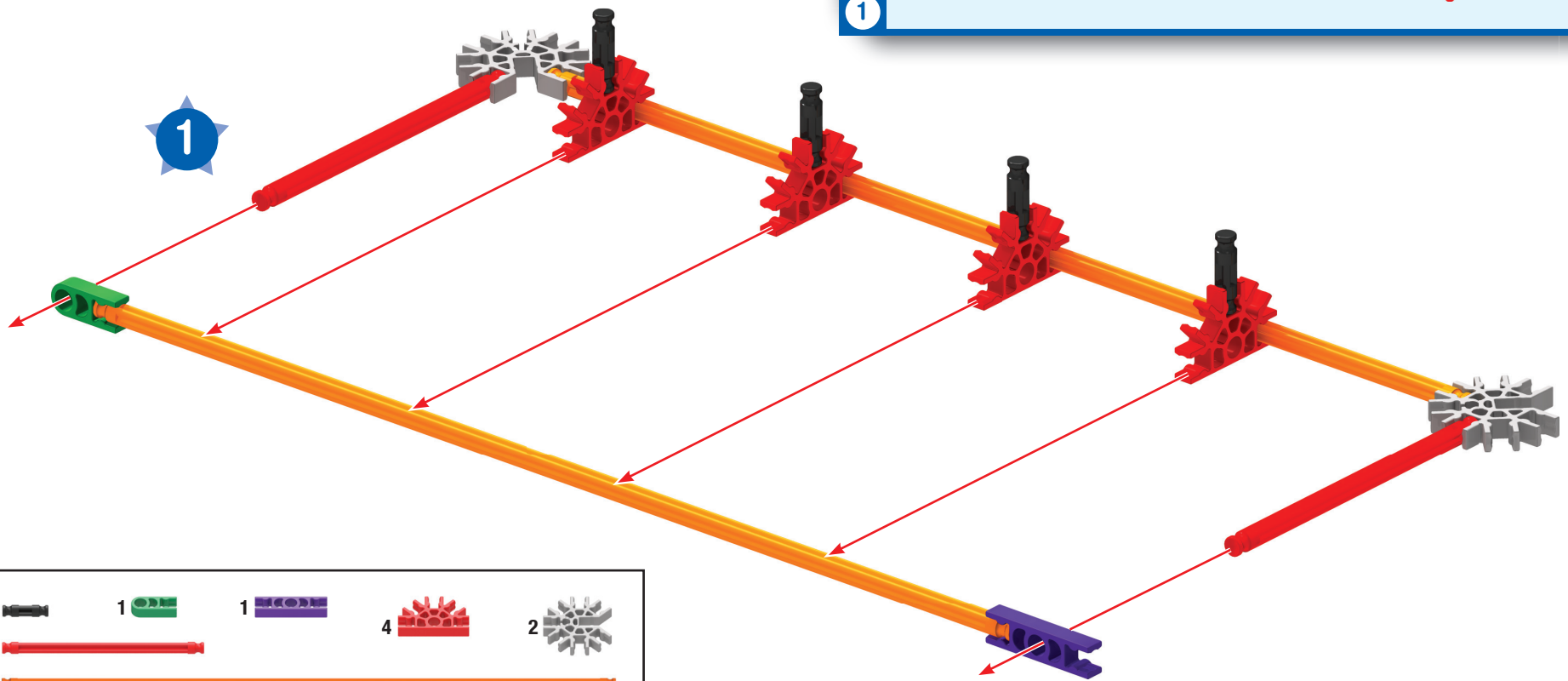
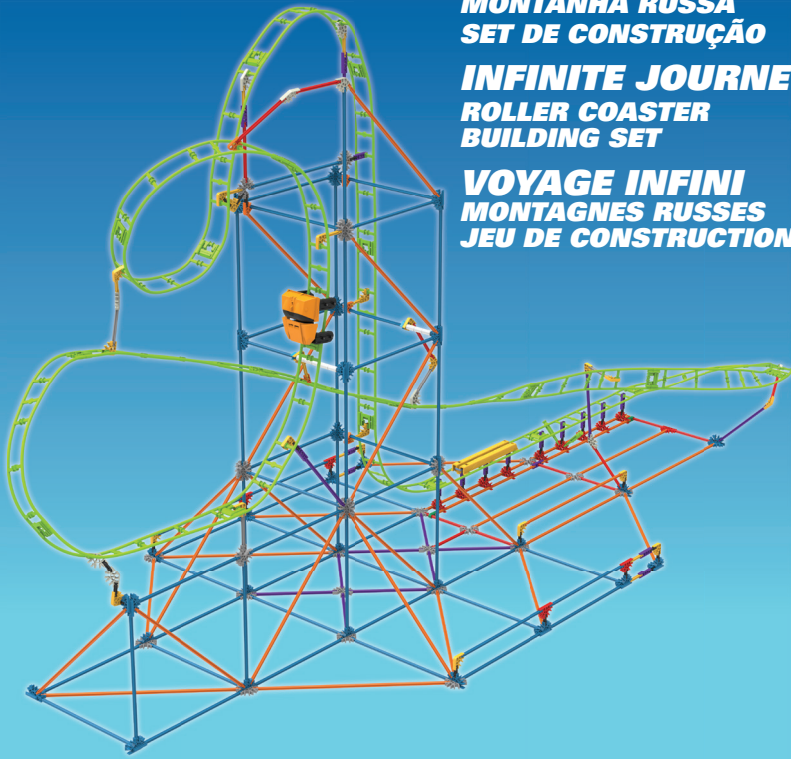

Avant de commencer à construire, assure-toi de comparer les pièces dans ta boîte à la liste de pièces fournie ici. S'il manque quelque chose, téléphone-nous ou écris-nous en te servant des informations figurant au verso de la notice. Nous sommes là pour t'aider !



INFINITE JOURNEY
MONTAÑA RUSA
SET DE CONSTRUCCIÓN
INFINITE JOURNEY
MONTANHA RUSSA
SET DE CONSTRUÇÃO
INFINITE JOURNEY
ROLLER COASTER
BUILDING SET
VOYAGE INFINI
MONTAGNES RUSSES
JEU DE CONSTRUCTION



- | | | | | | | | | | |
|---|--|---|--|---|--|---|--|---|--|
| 4 | | 1 | | 1 | | 4 | | 2 | |
| 2 | | | | | | | | | |
| 2 | | | | | | | | | |



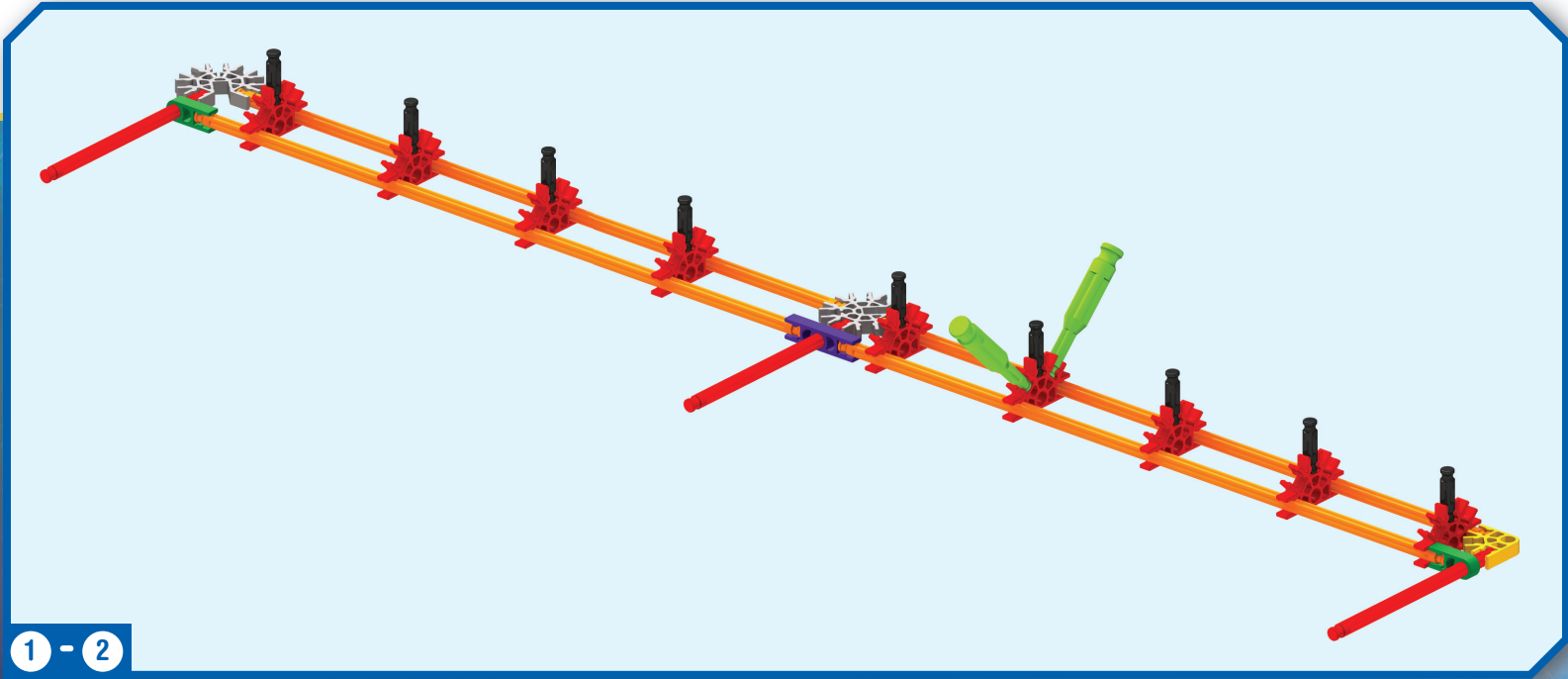
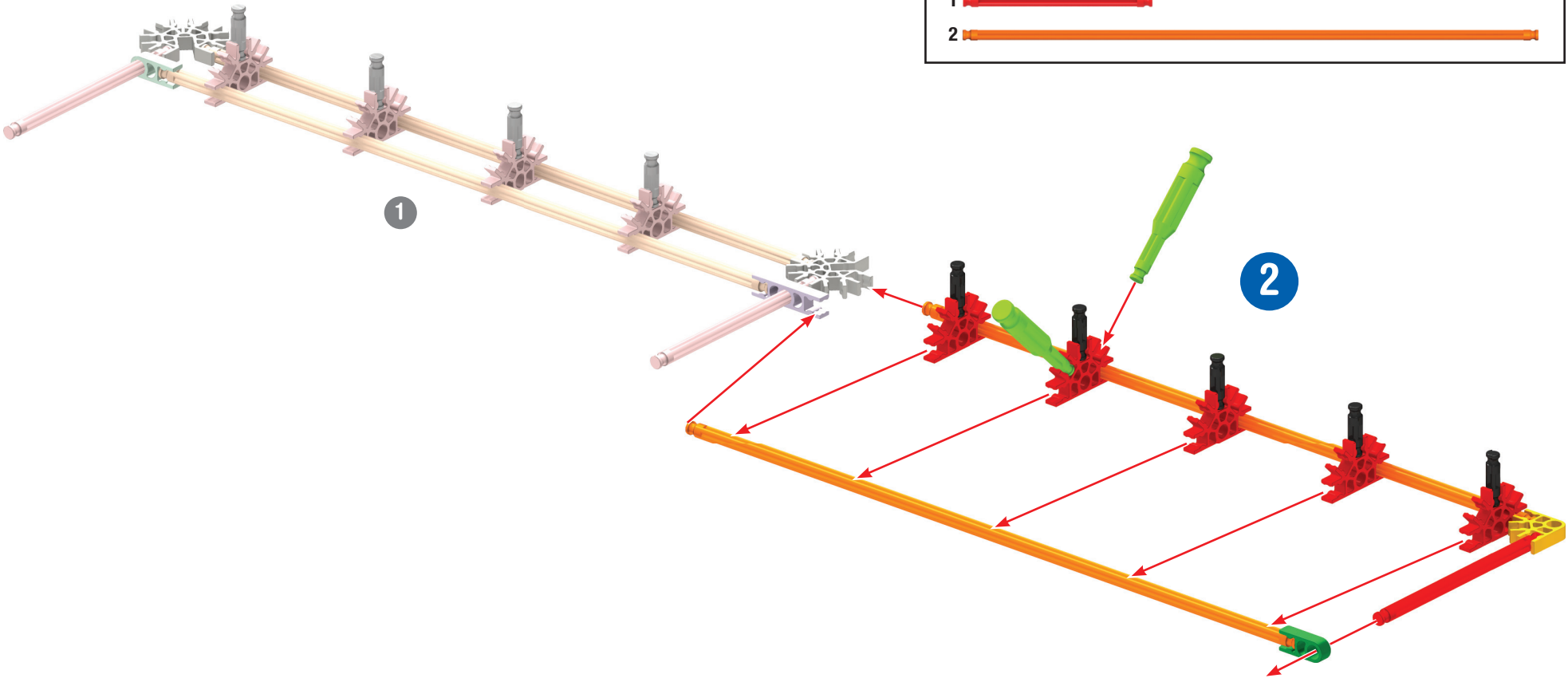

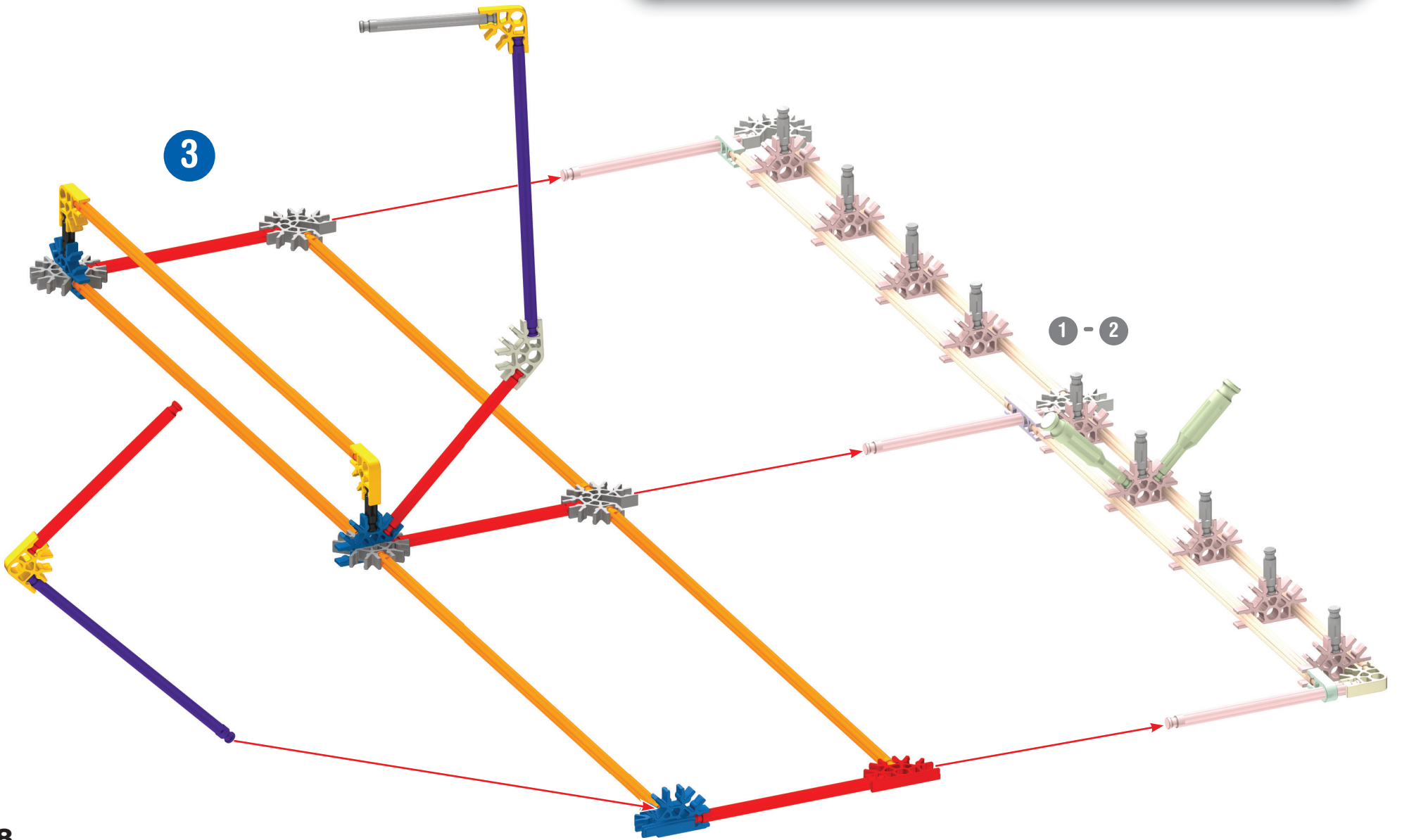
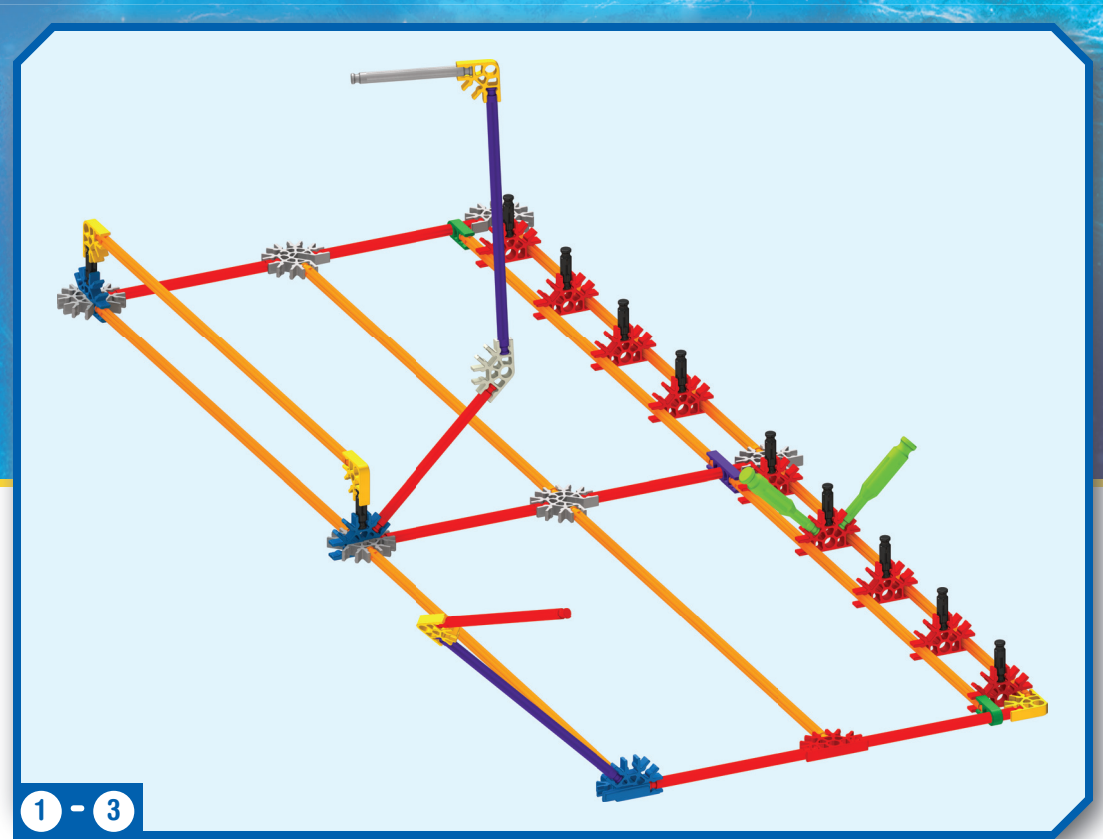
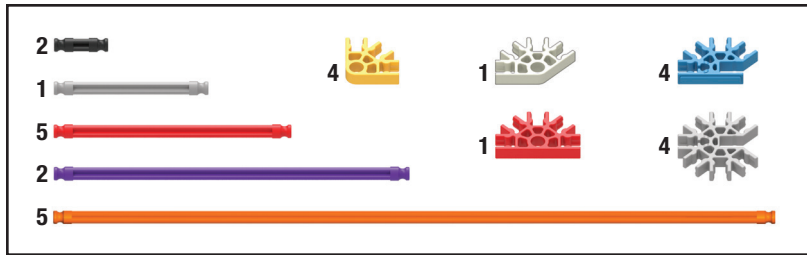

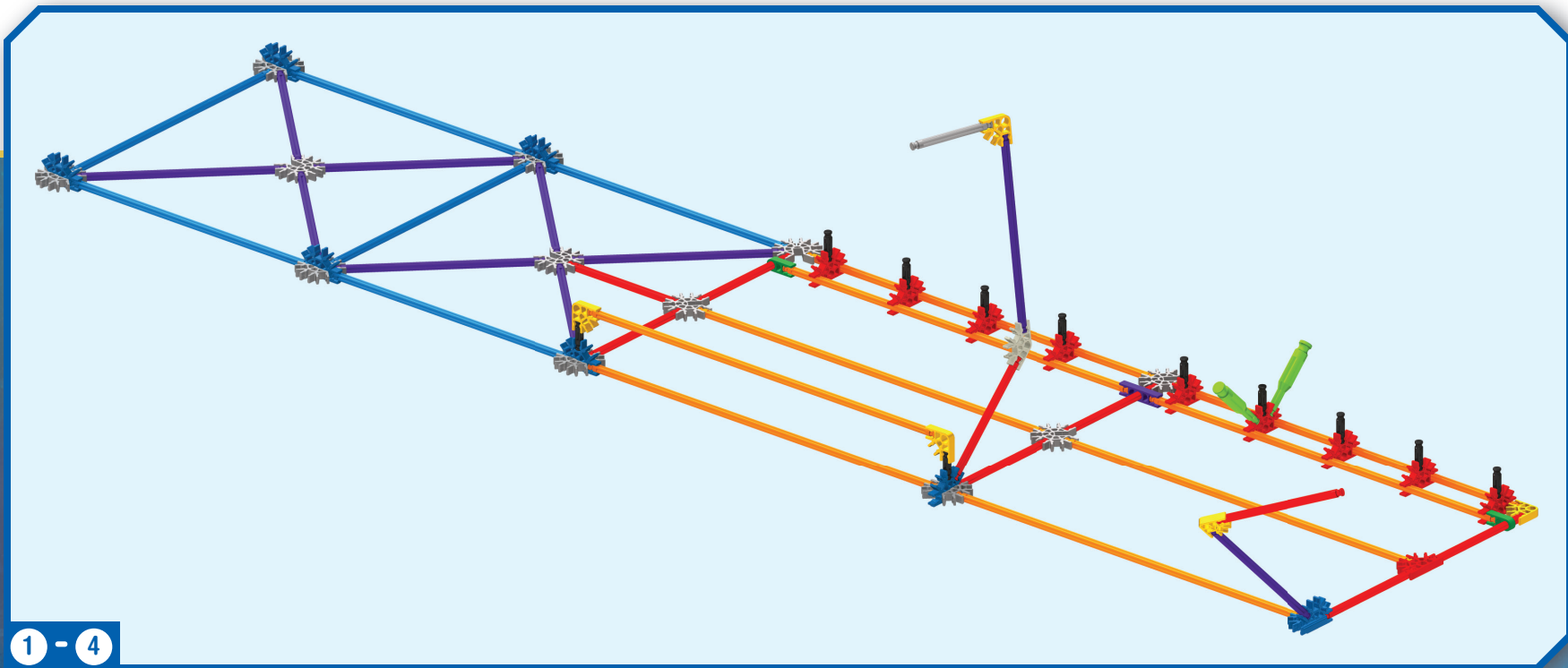
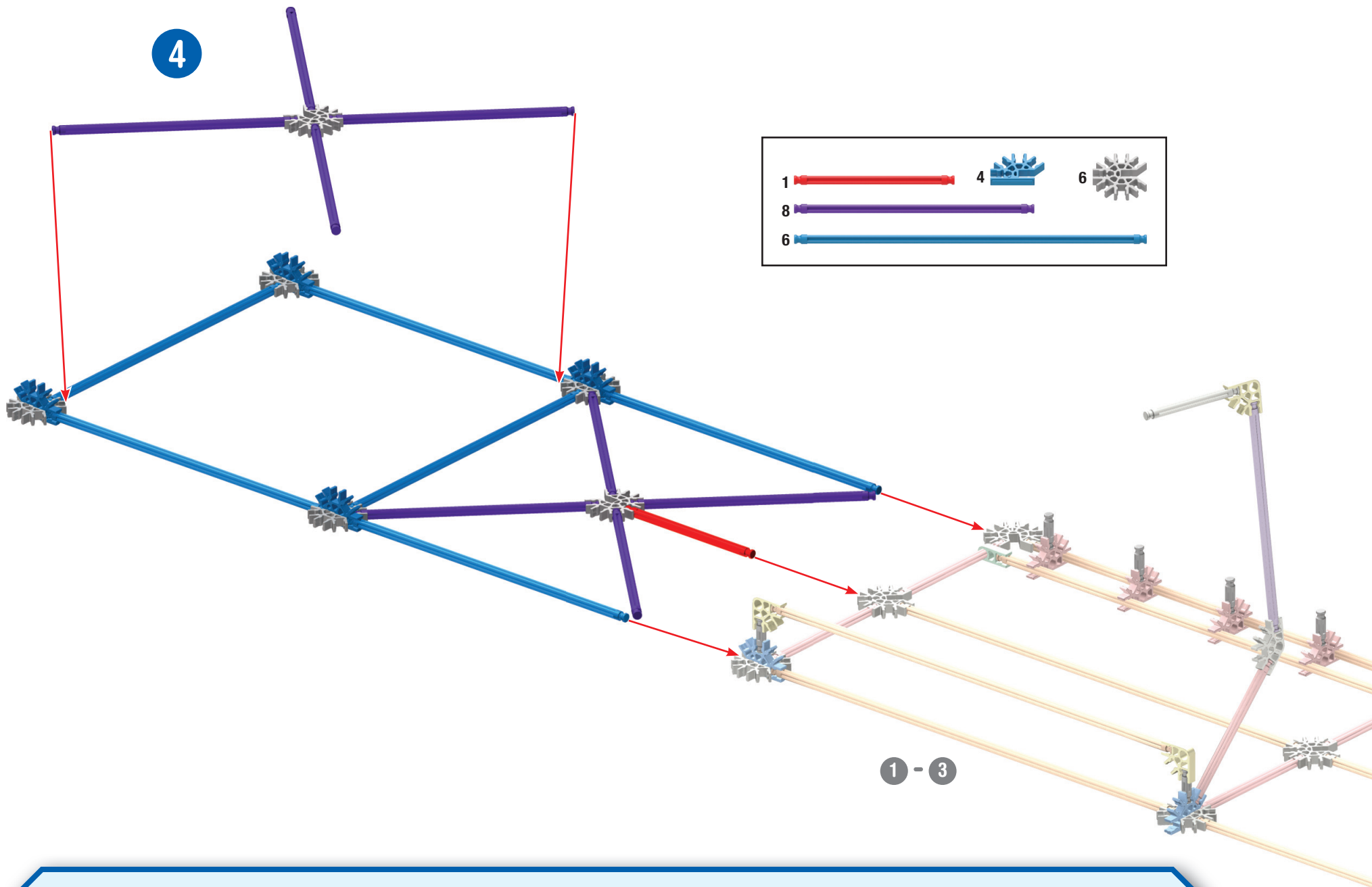

5		2		1		1		5	
1									
2									





4



2		2		7	
6		2		1	
2					
7					

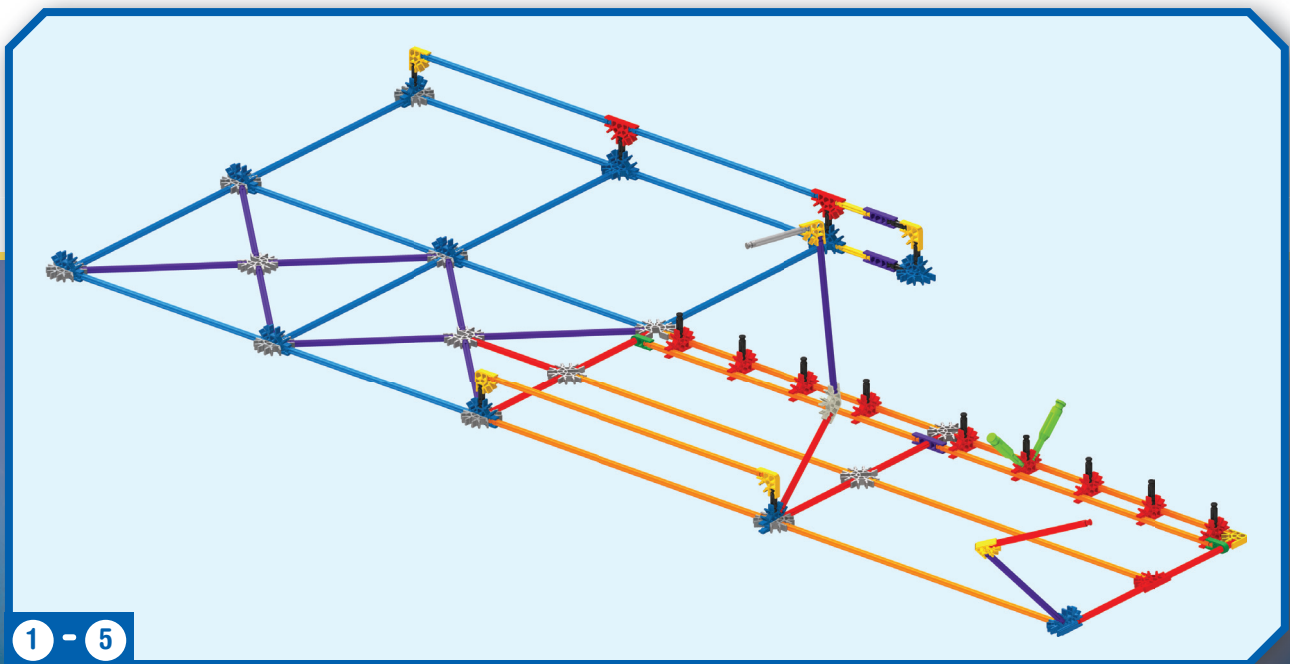
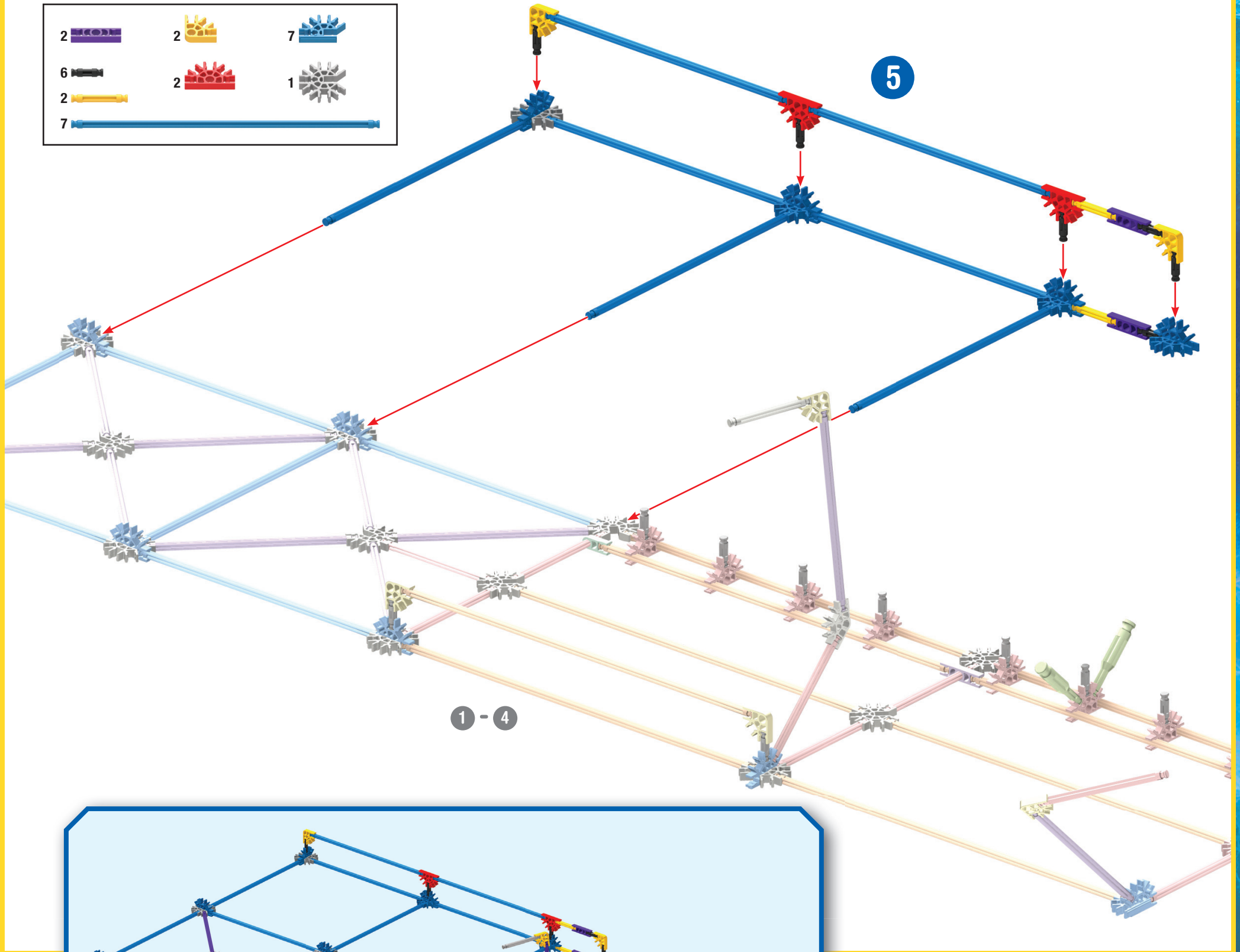

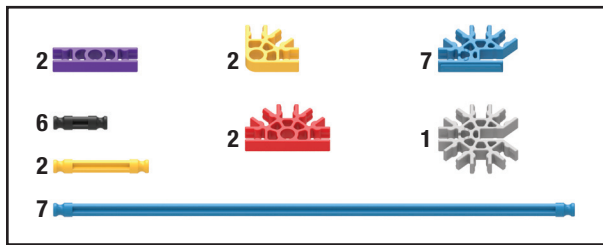

1 - 5

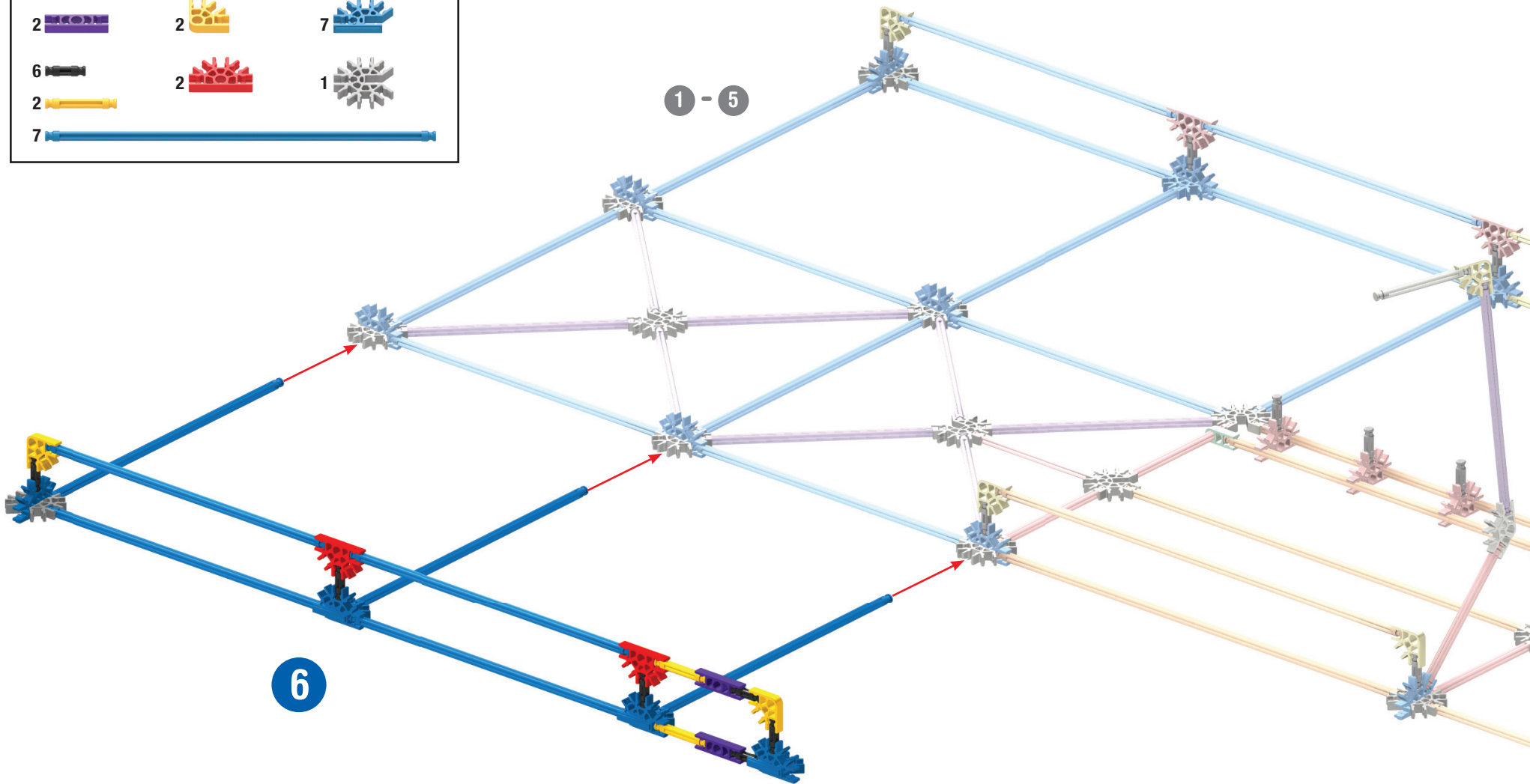

6

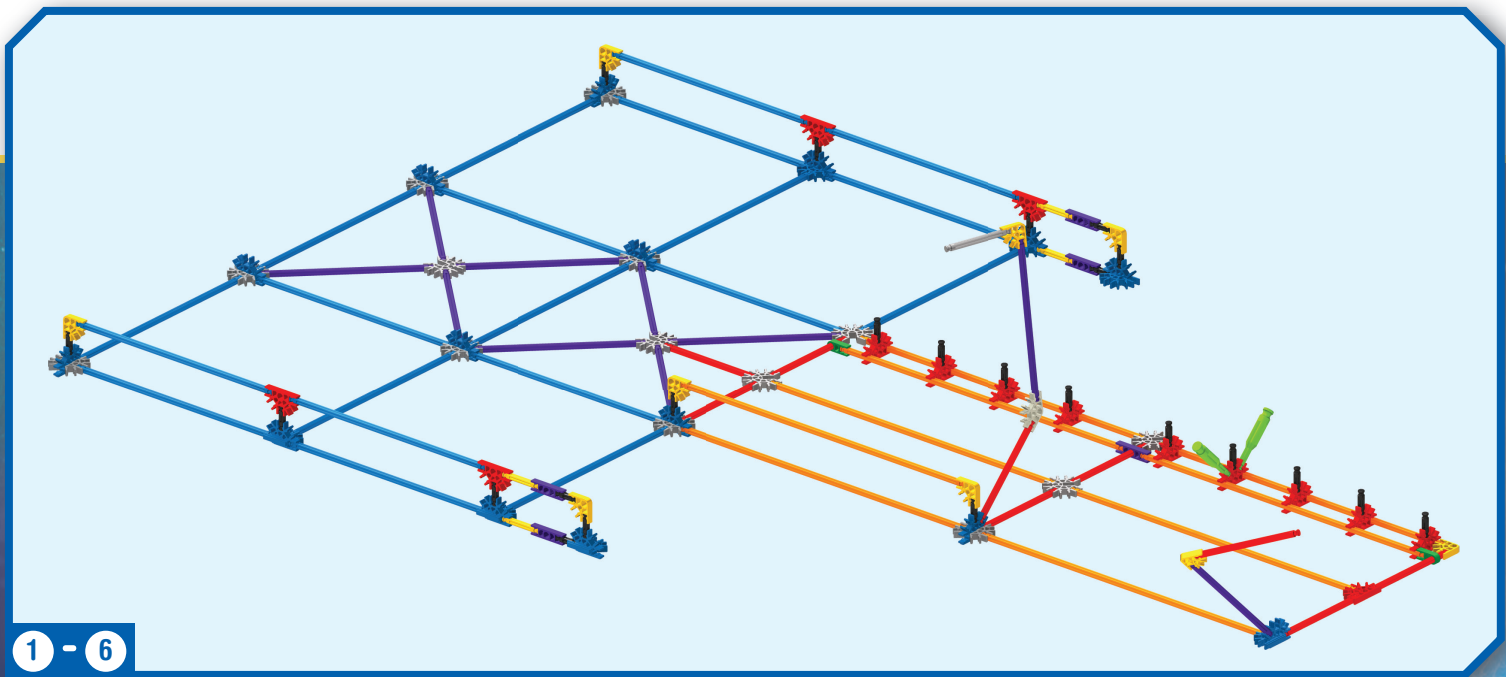

1 - 6

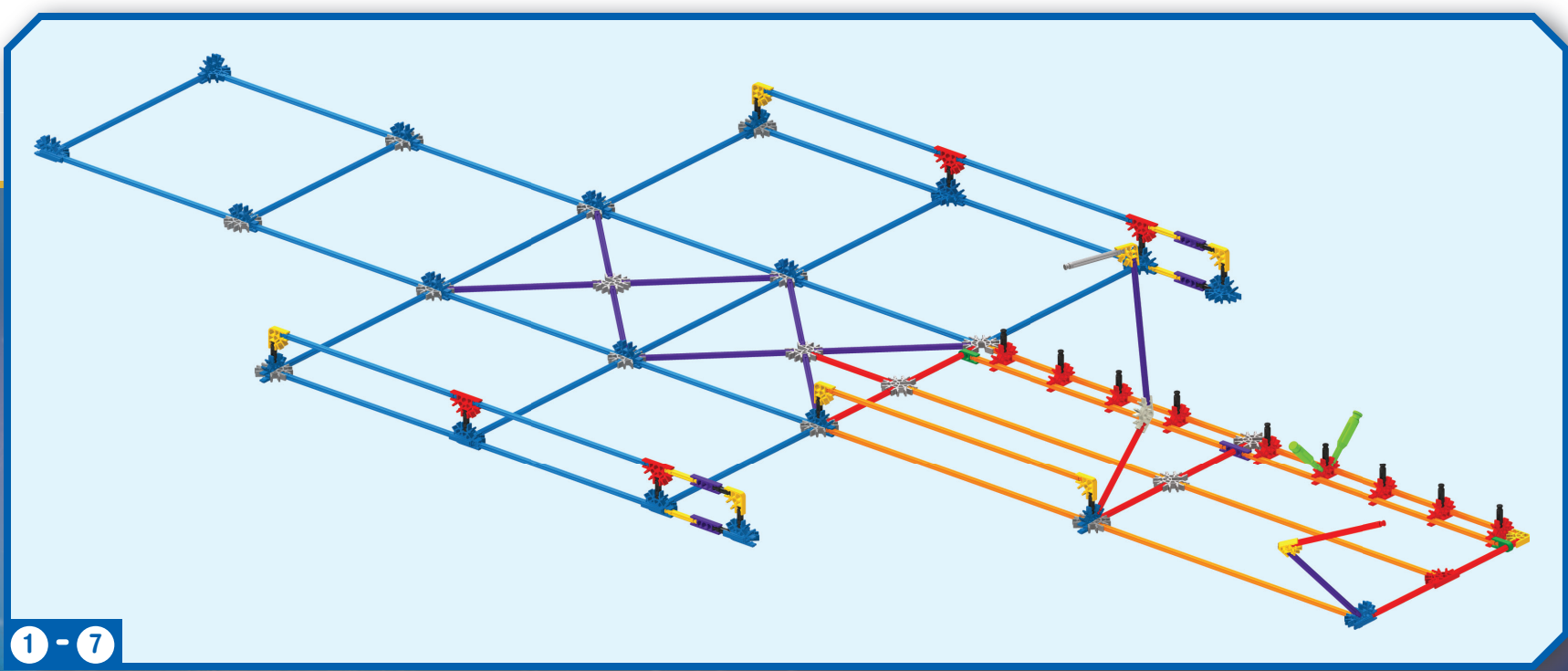
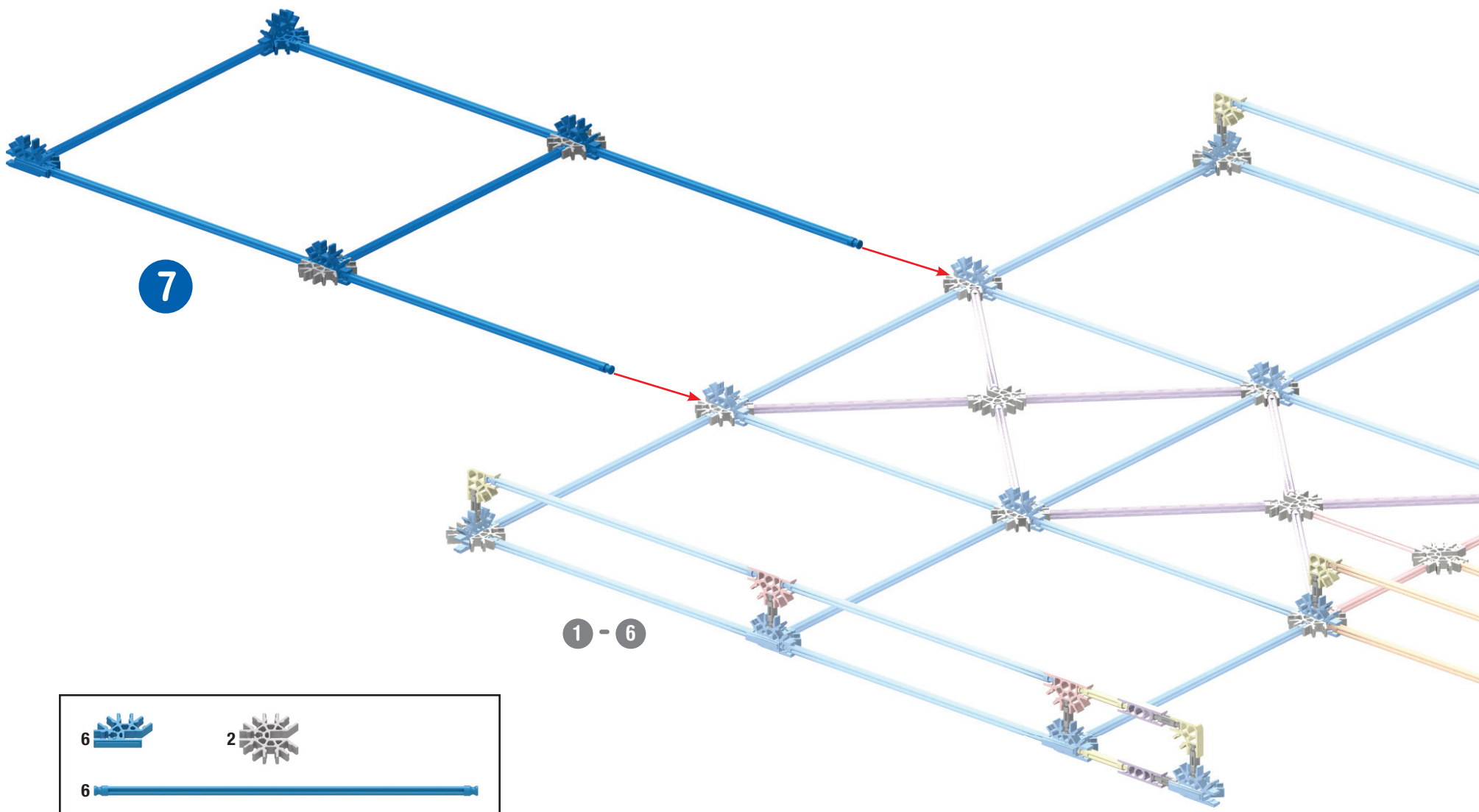

8

1 - 7

9

1 - 8

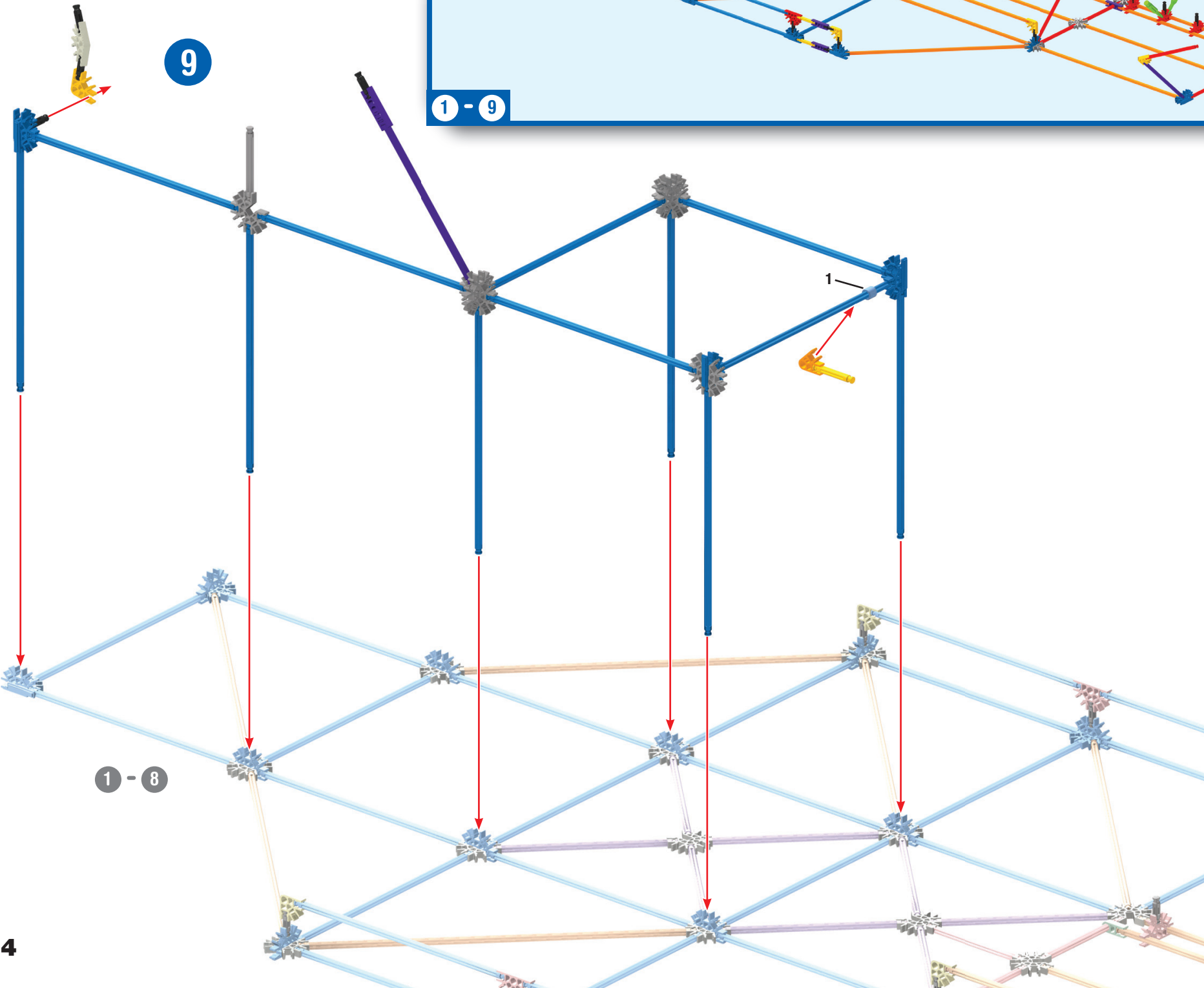
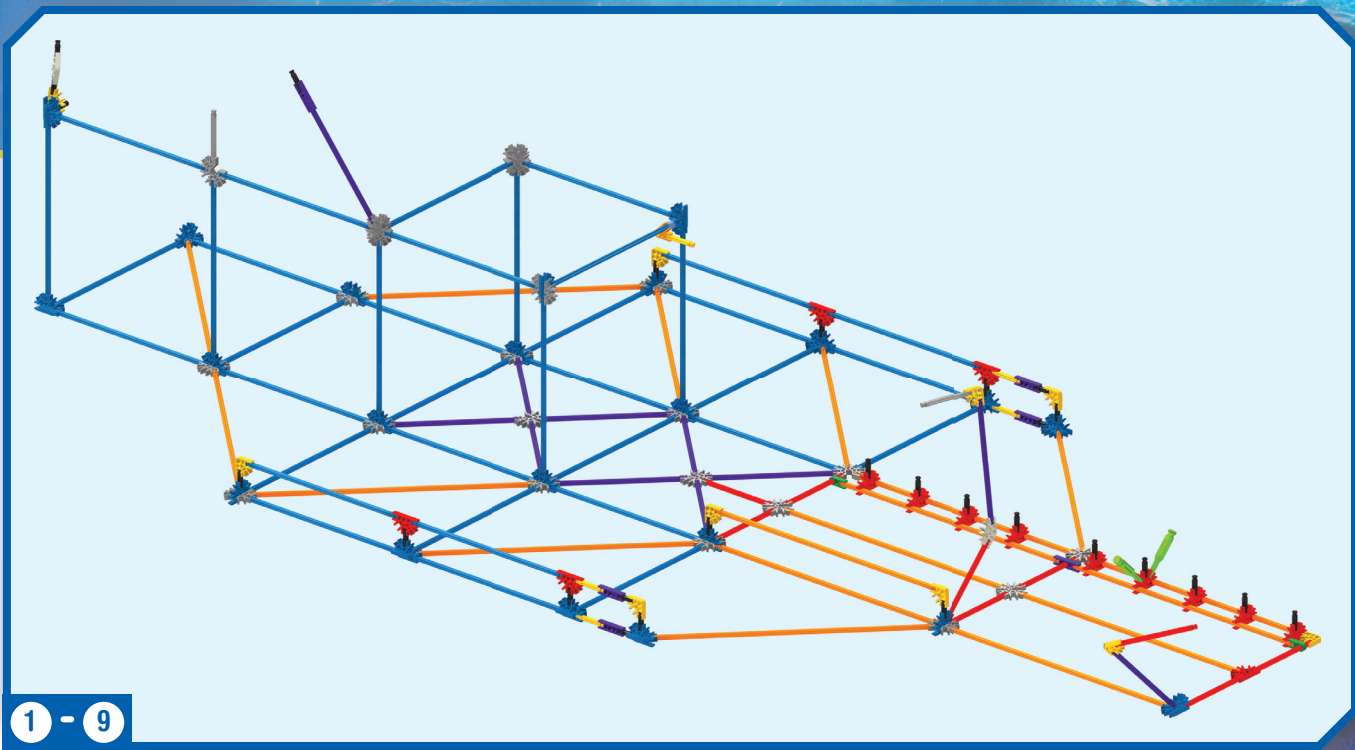
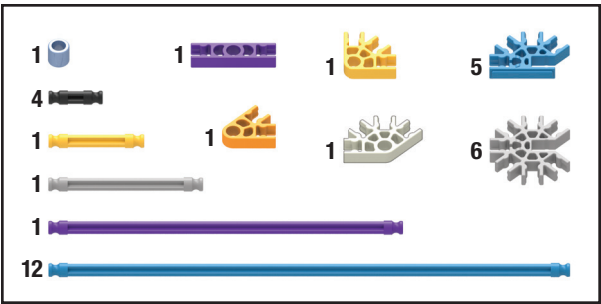

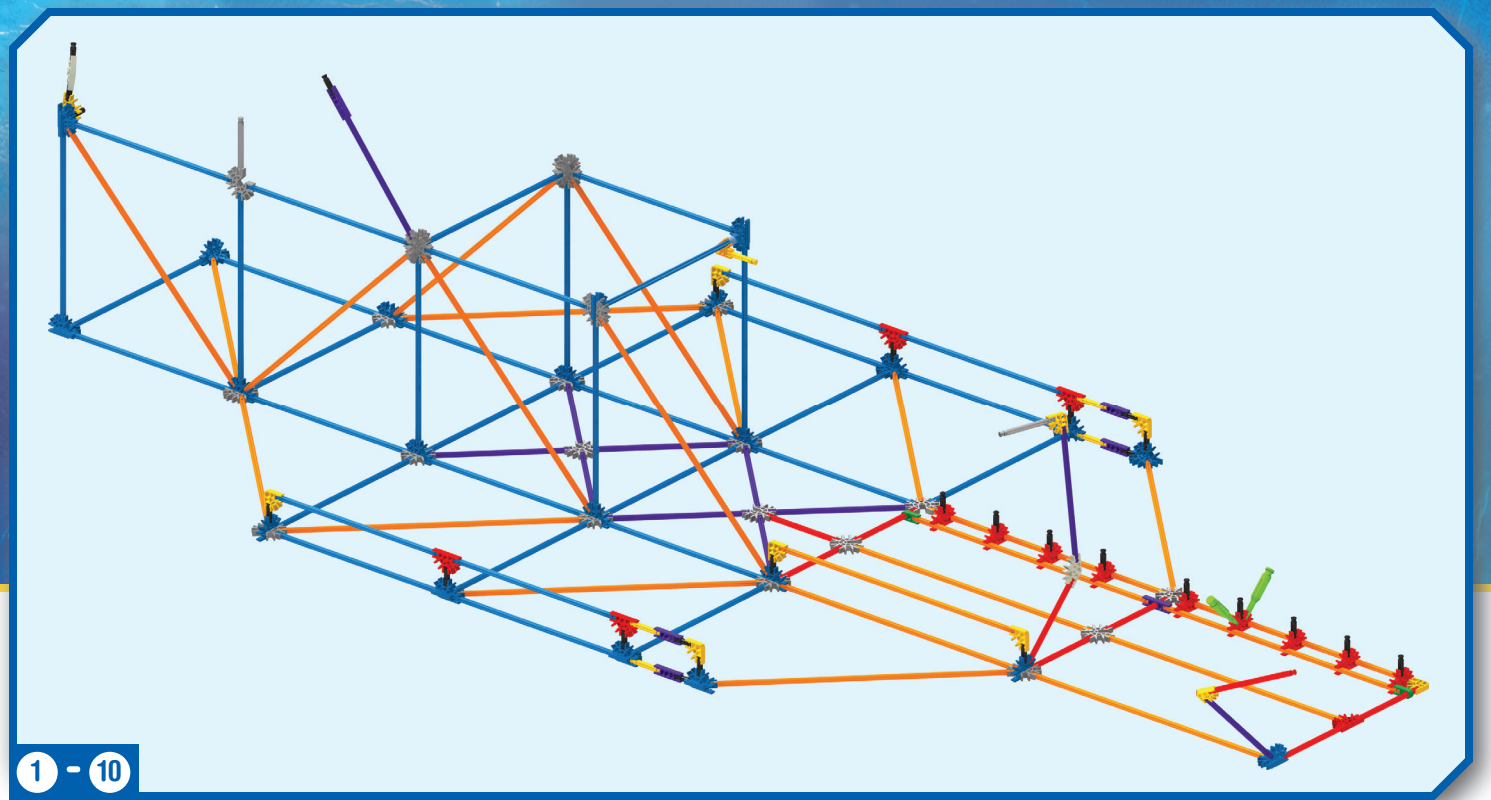

1 - 10



6

10

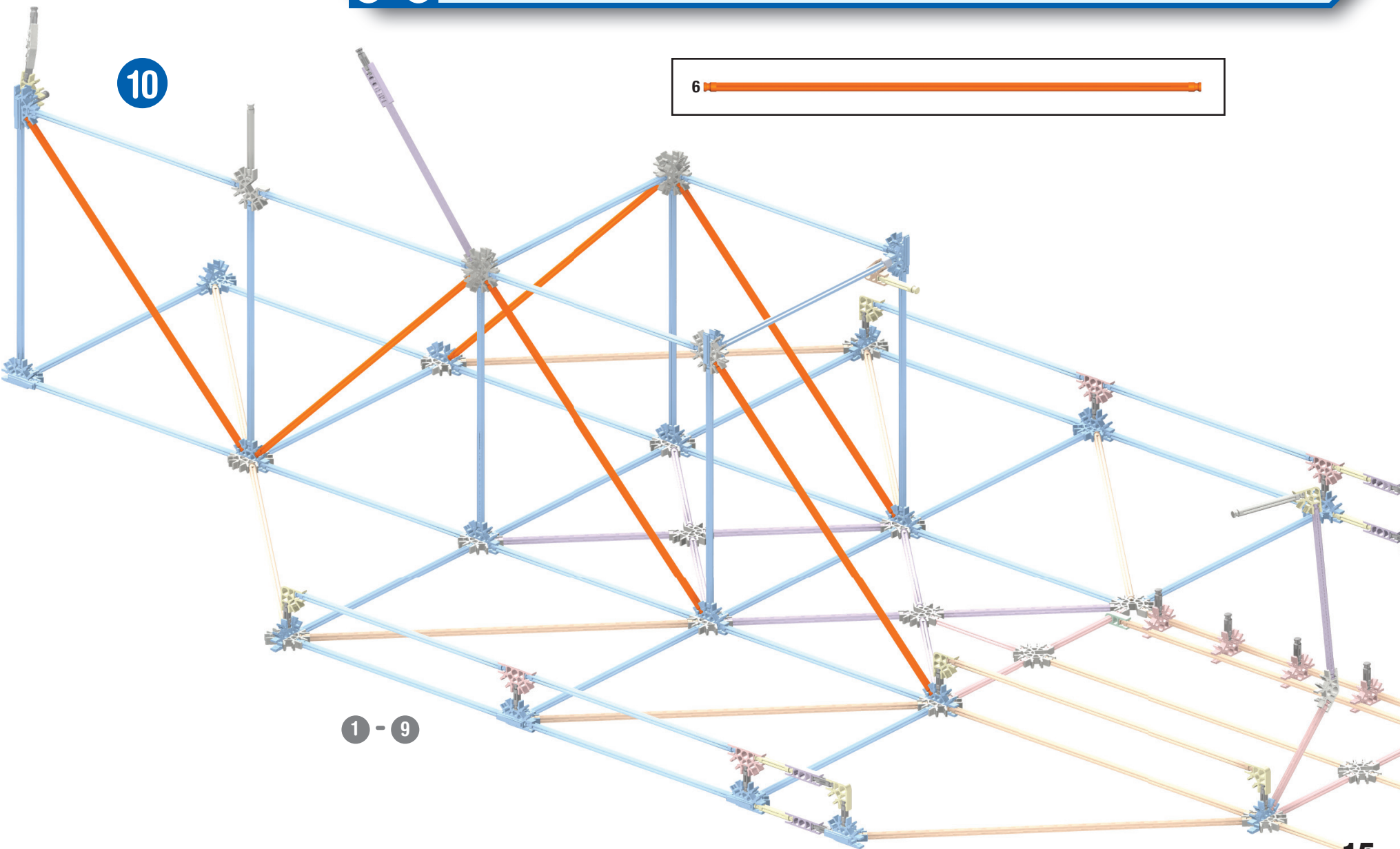

1 - 9

15

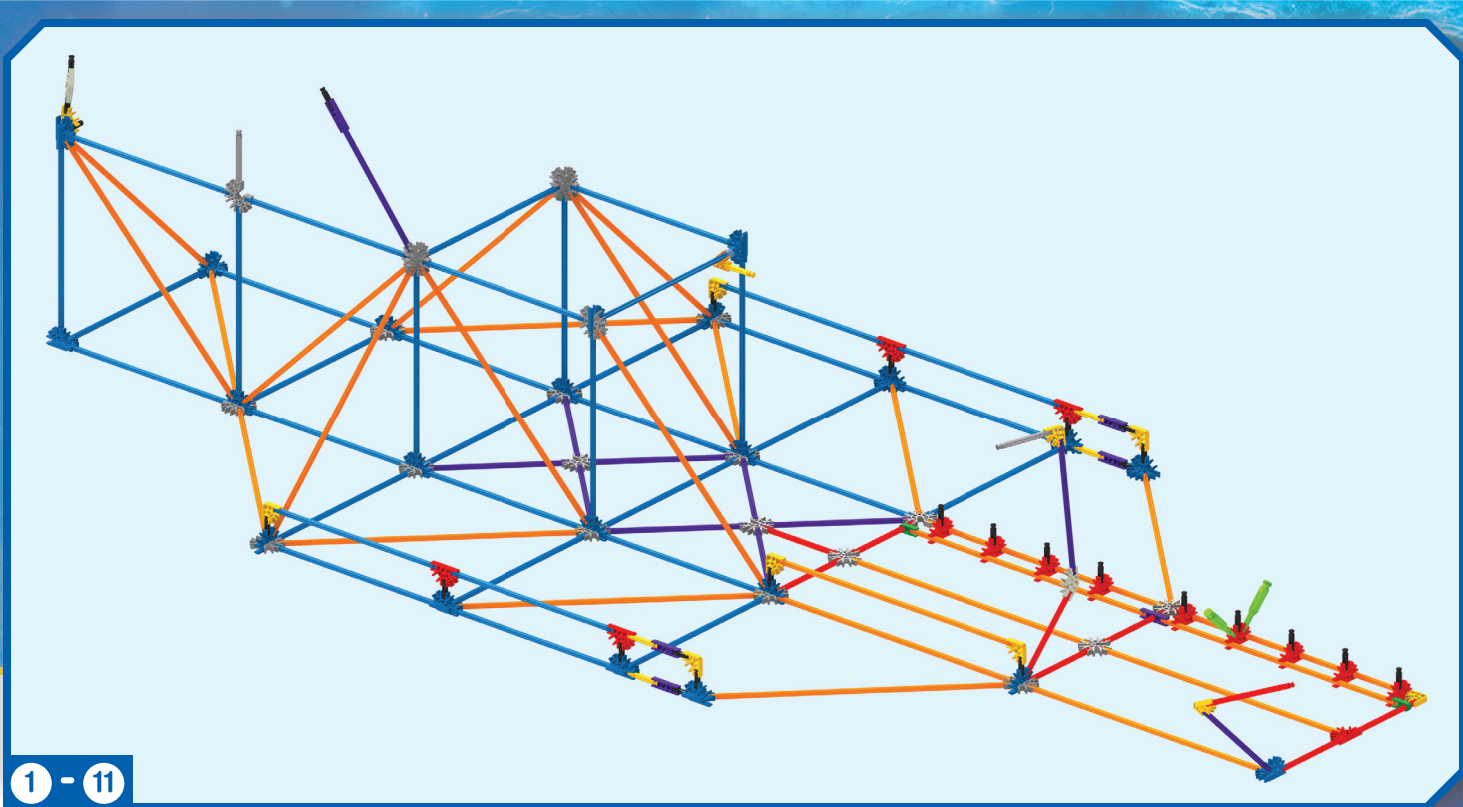

1 - 11

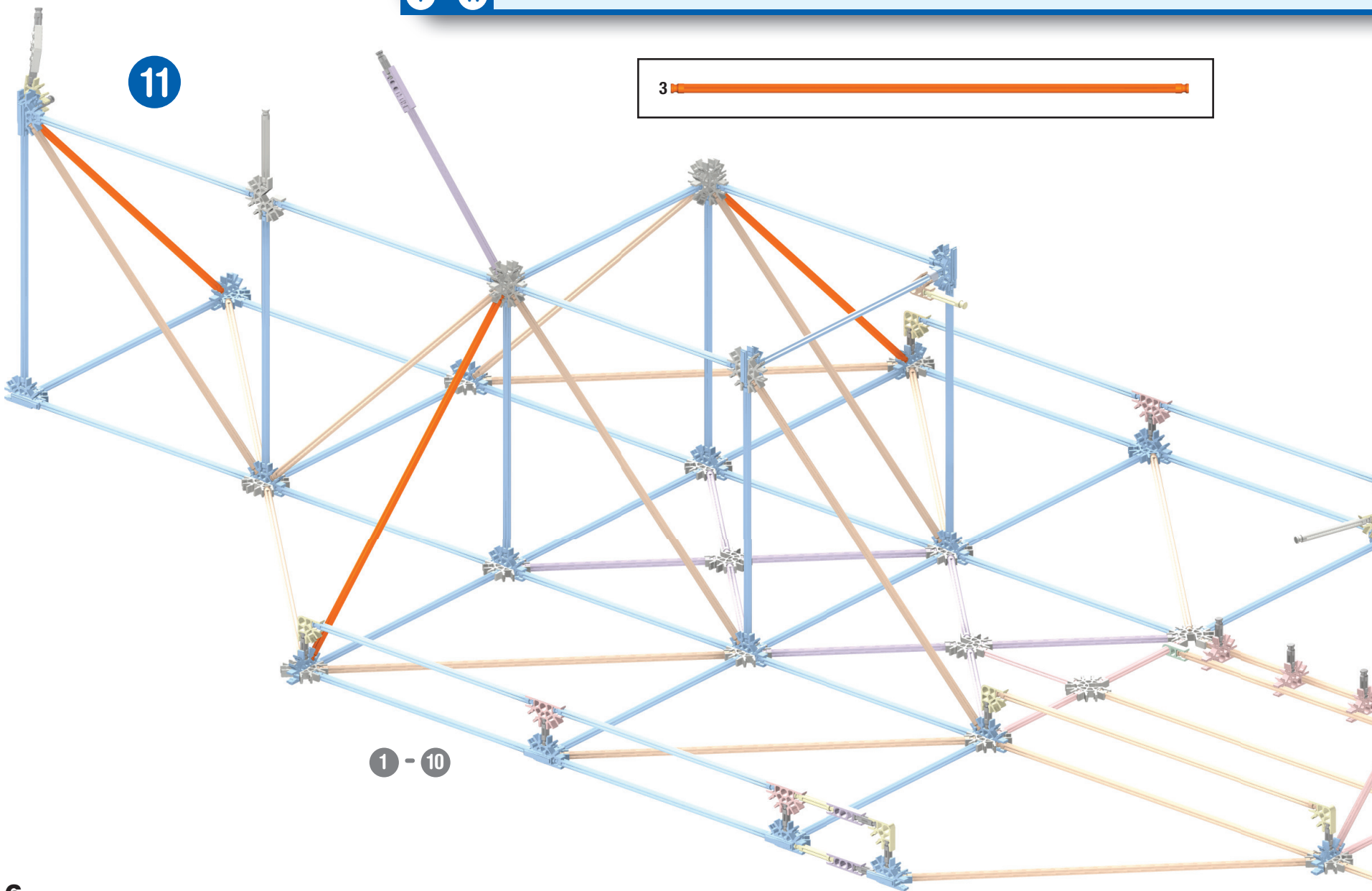

11

3

1 - 10

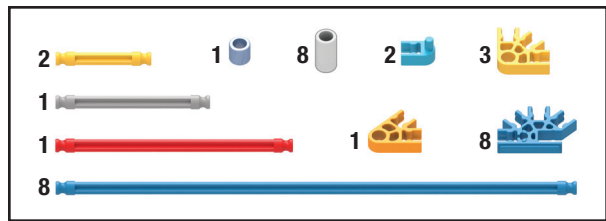

12

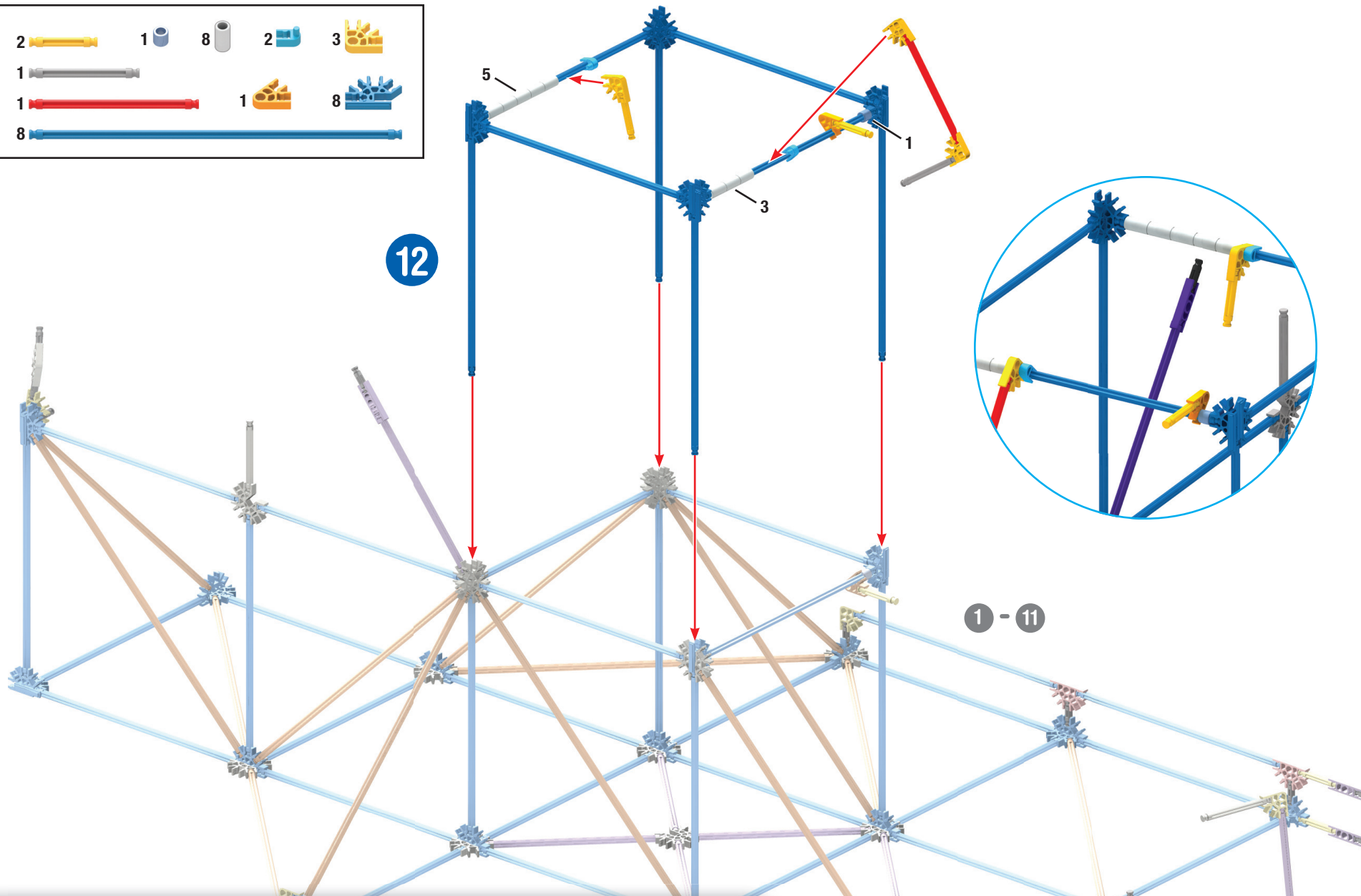

1 - 11

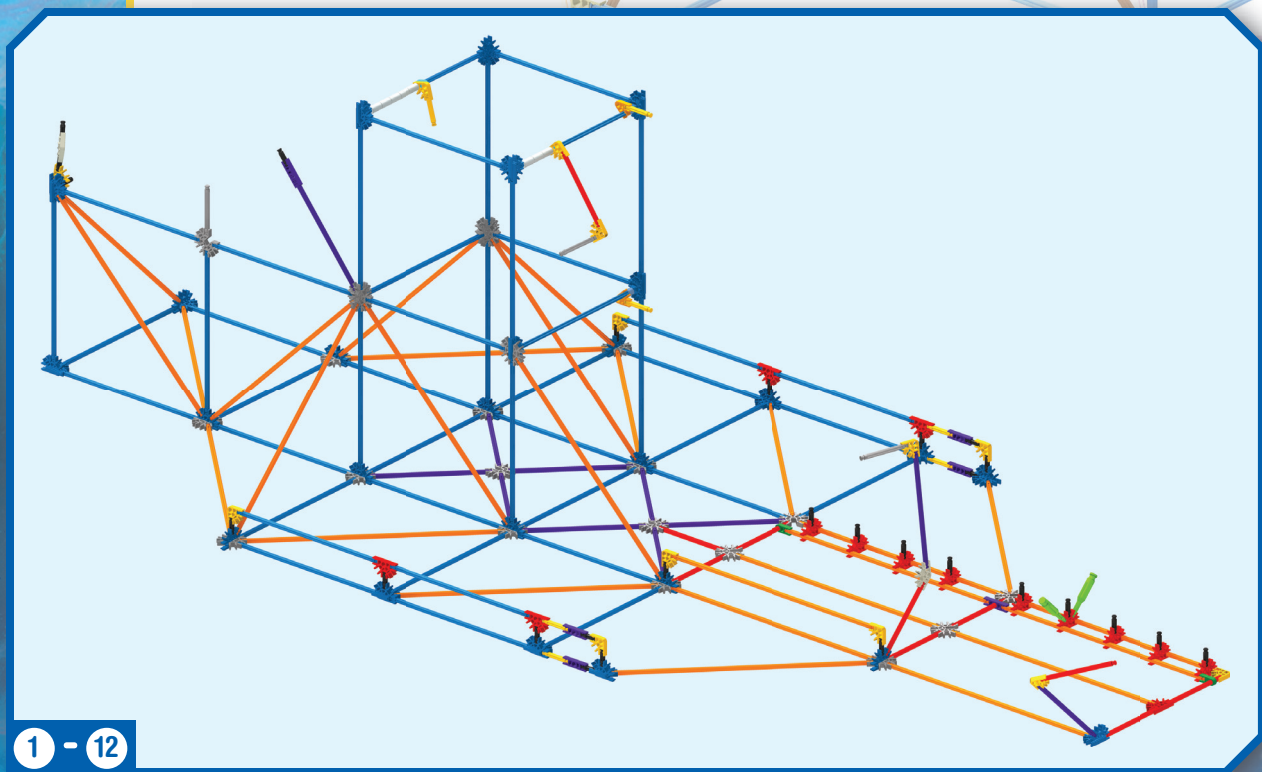

1 - 12

13

3	2	2	6
3	2	2	4
3	1	2	4
10			

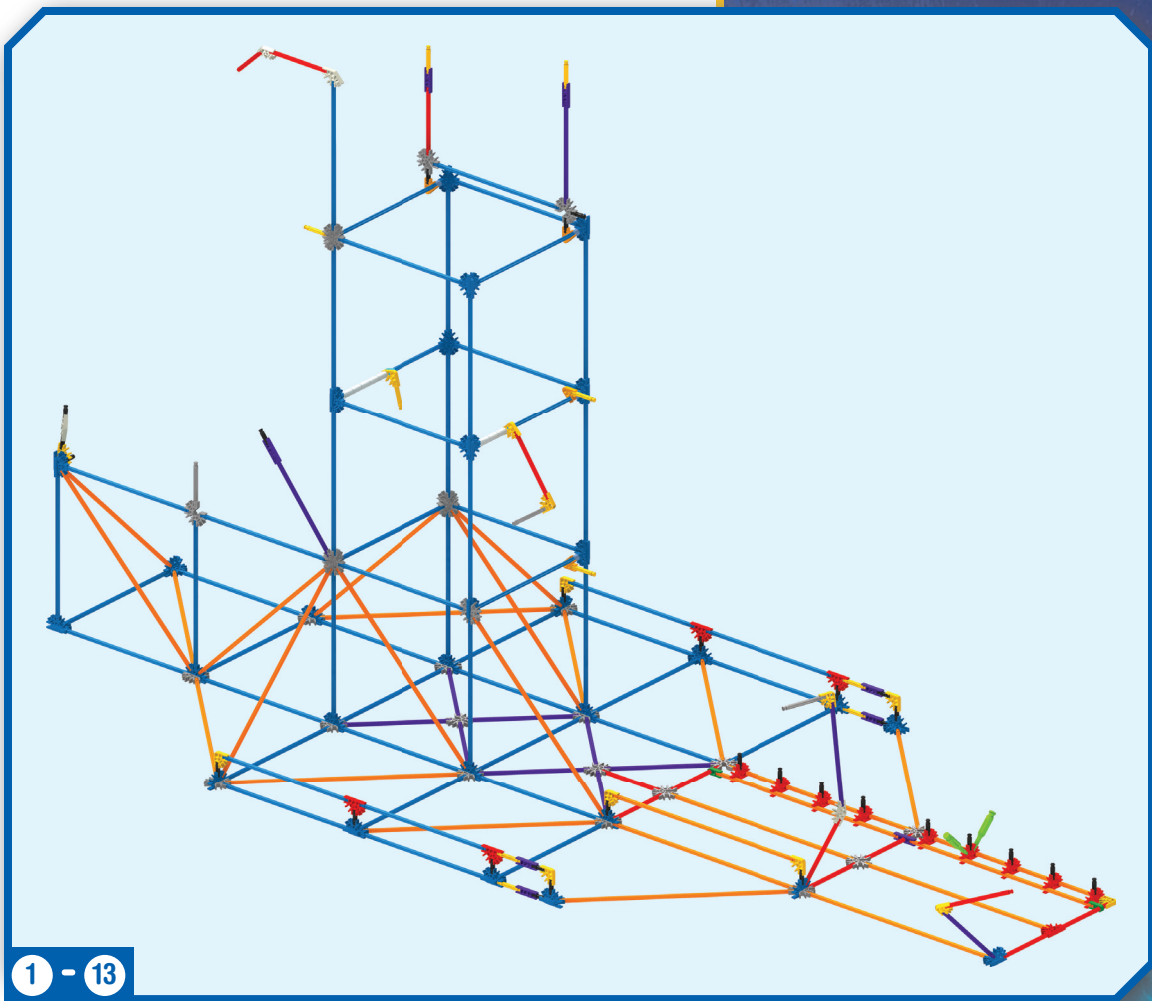

1 - 12

18

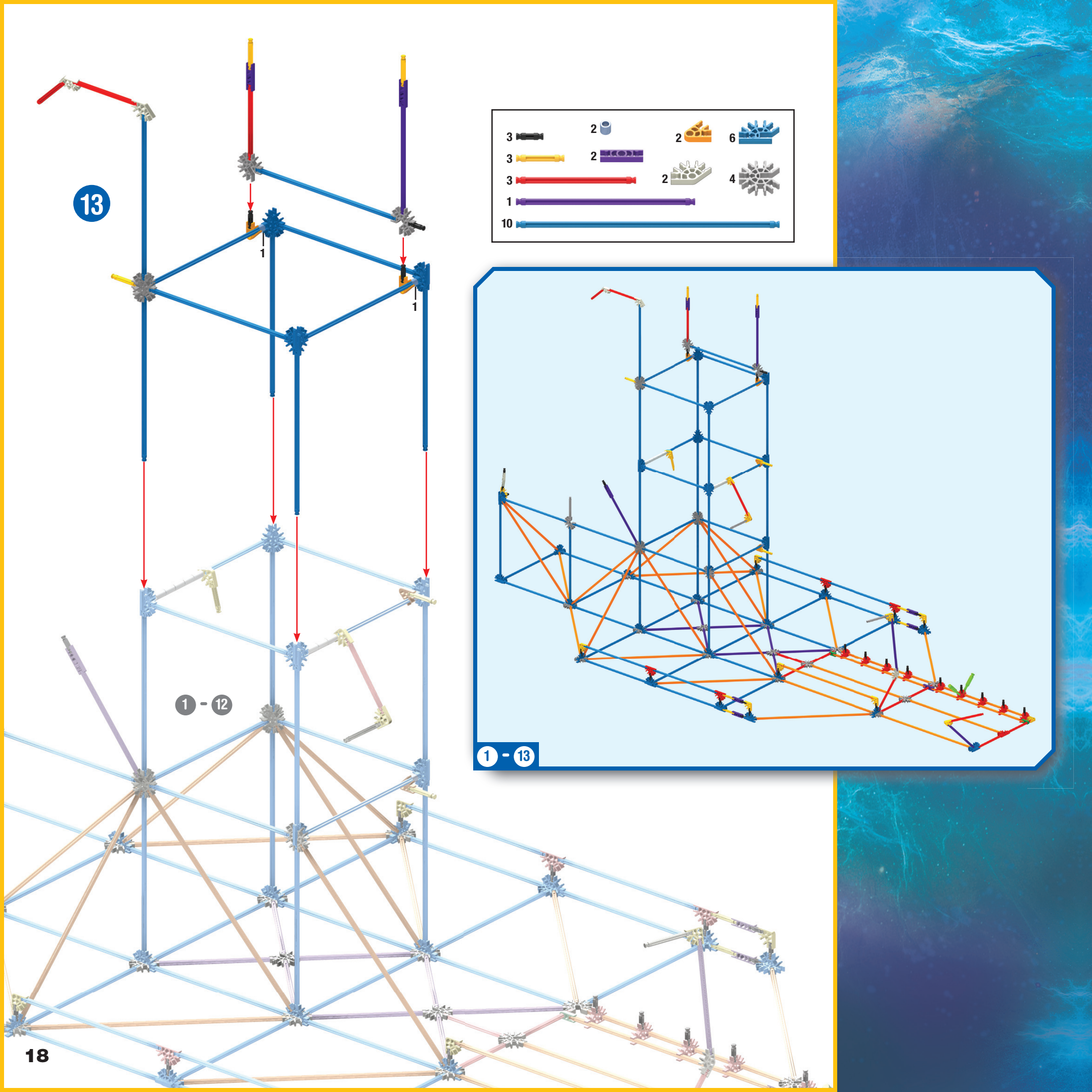

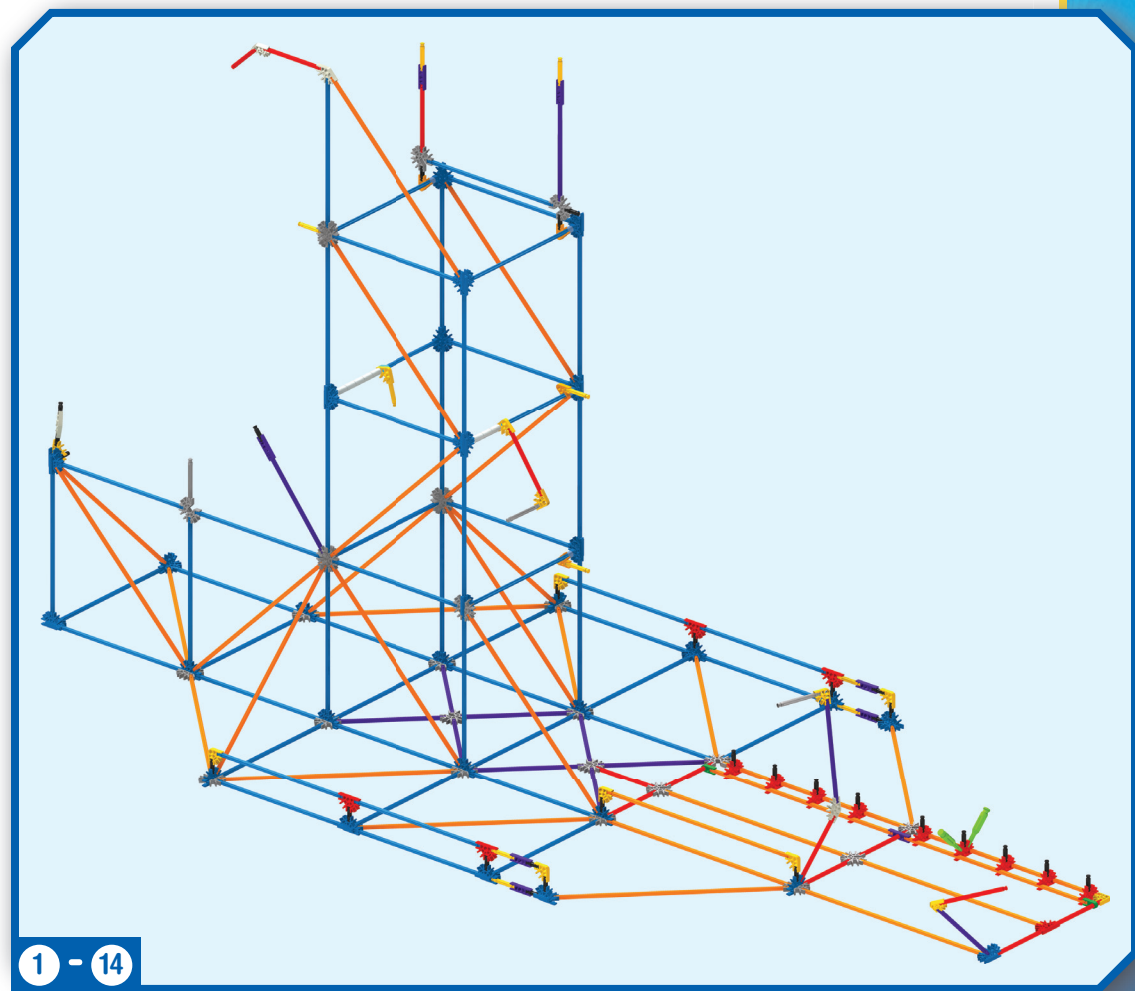
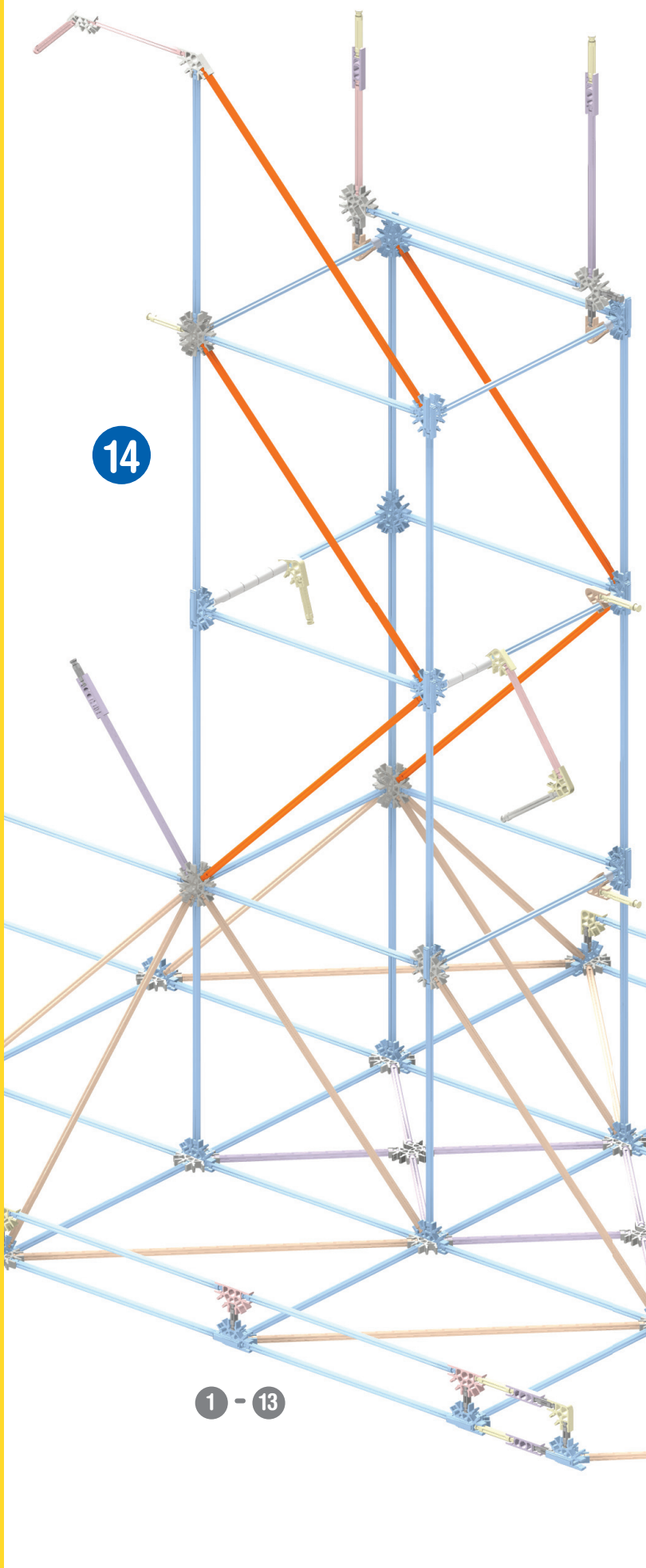

15

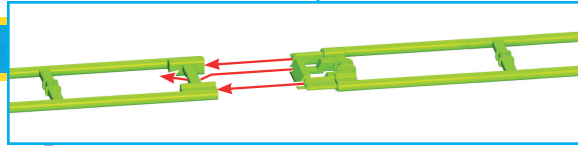
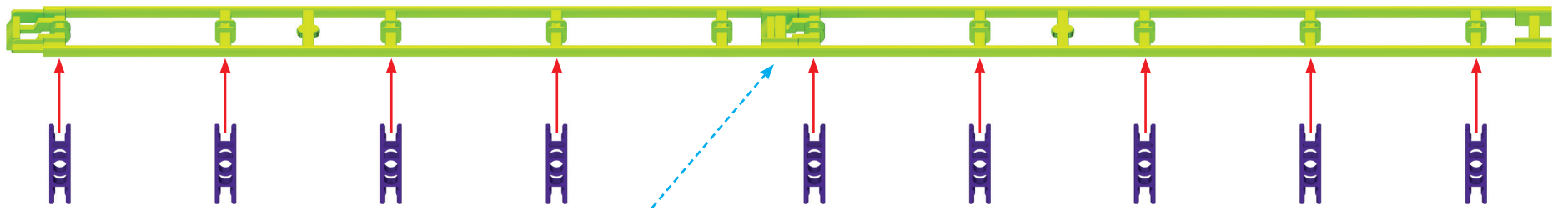

Empuja los conectores hacia adentro hasta que oigas un “clic”.
 Faz avançar os conectores firmemente até “encaixarem” com um estalido.
 Be sure to push the connectors on firmly until they “click”.
 Pousse bien les connecteurs jusqu’à ce qu’ils « cliquent ».

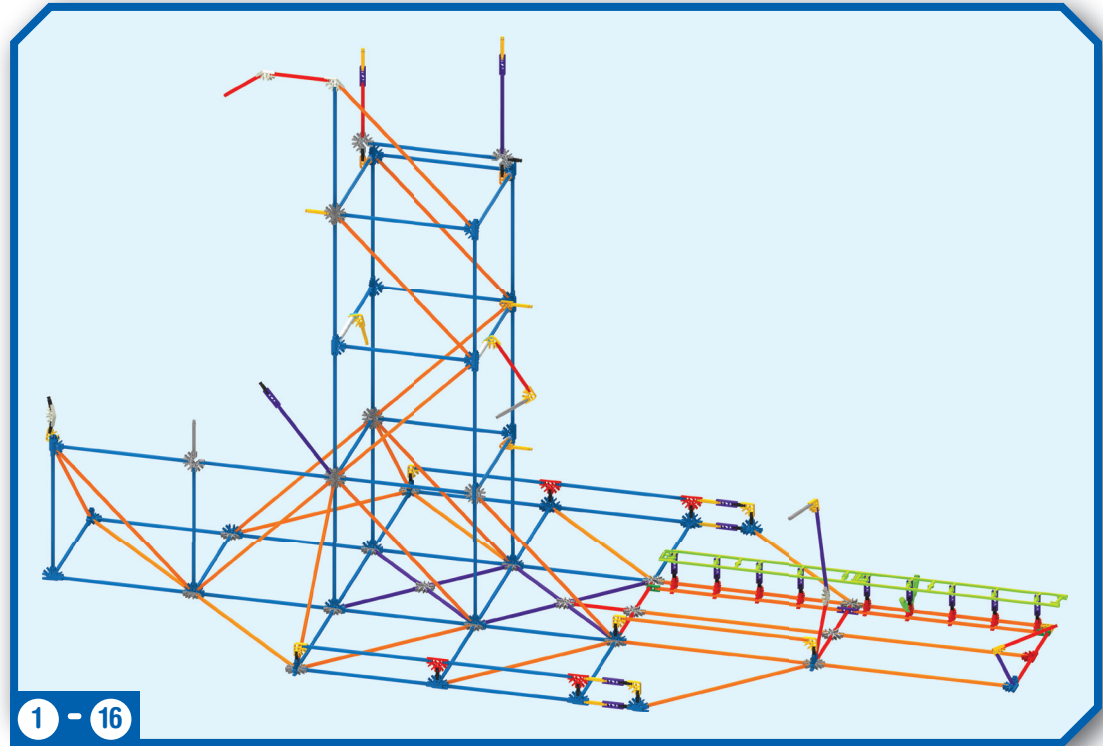

16

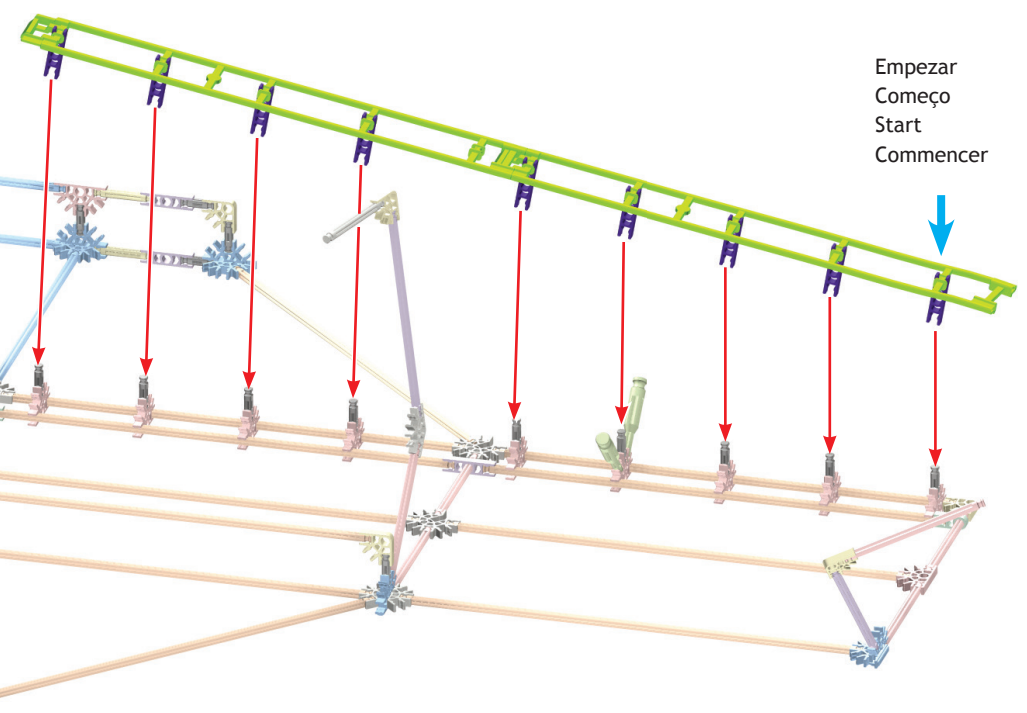

Empezar
 Começo
 Start
 Commencer

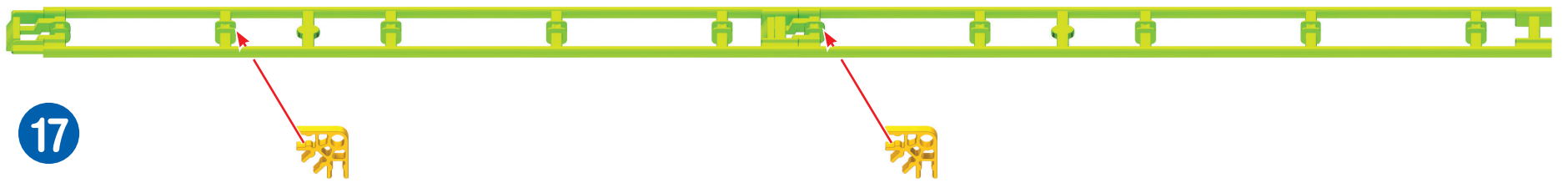

17

18

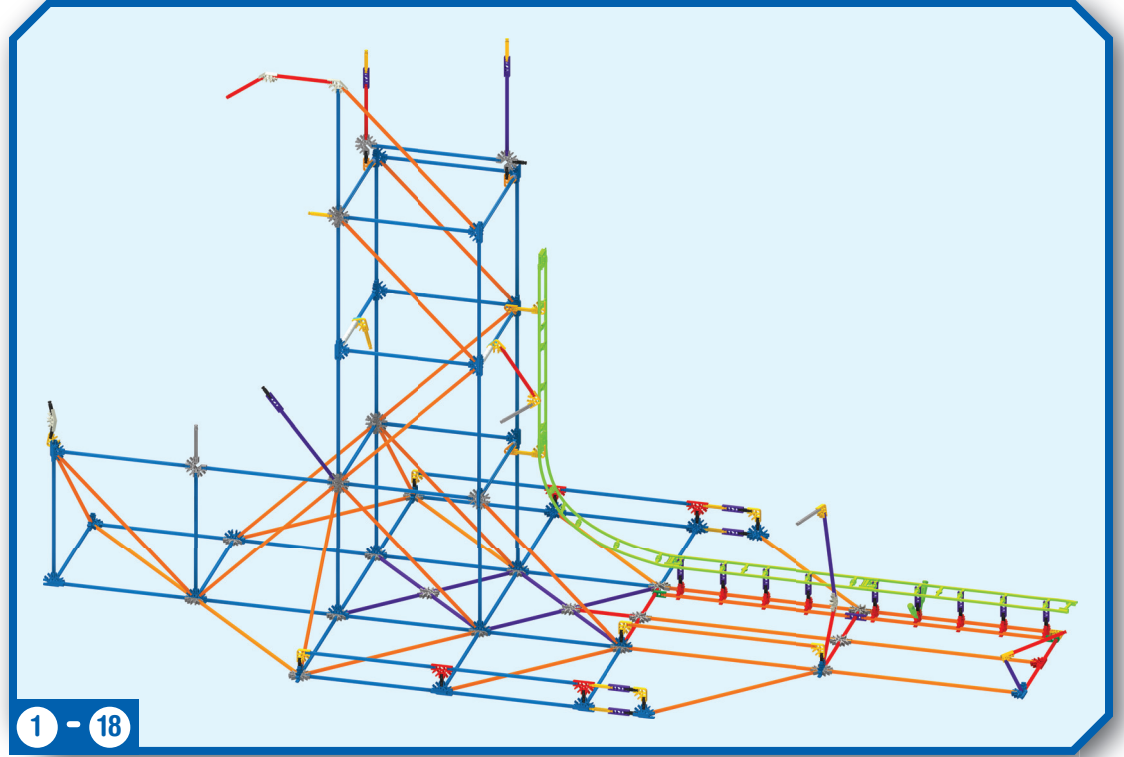

1 - 18

Siempre unirse a este extremo de la pista a la pieza primera pista anterior, a continuación, conecte el resto de la pista a la torre.
 Sempre aderir a este final da trilha para a peça faixa anterior primeiro, e depois conectar o restante da trilha para a torre.
 Always join this end of the track to the previous track piece first, then connect the rest of the track to the tower.
 Toujours joindre à cette extrémité de la voie à la pièce de la piste précédente, puis connecter le reste de la piste à la tour.

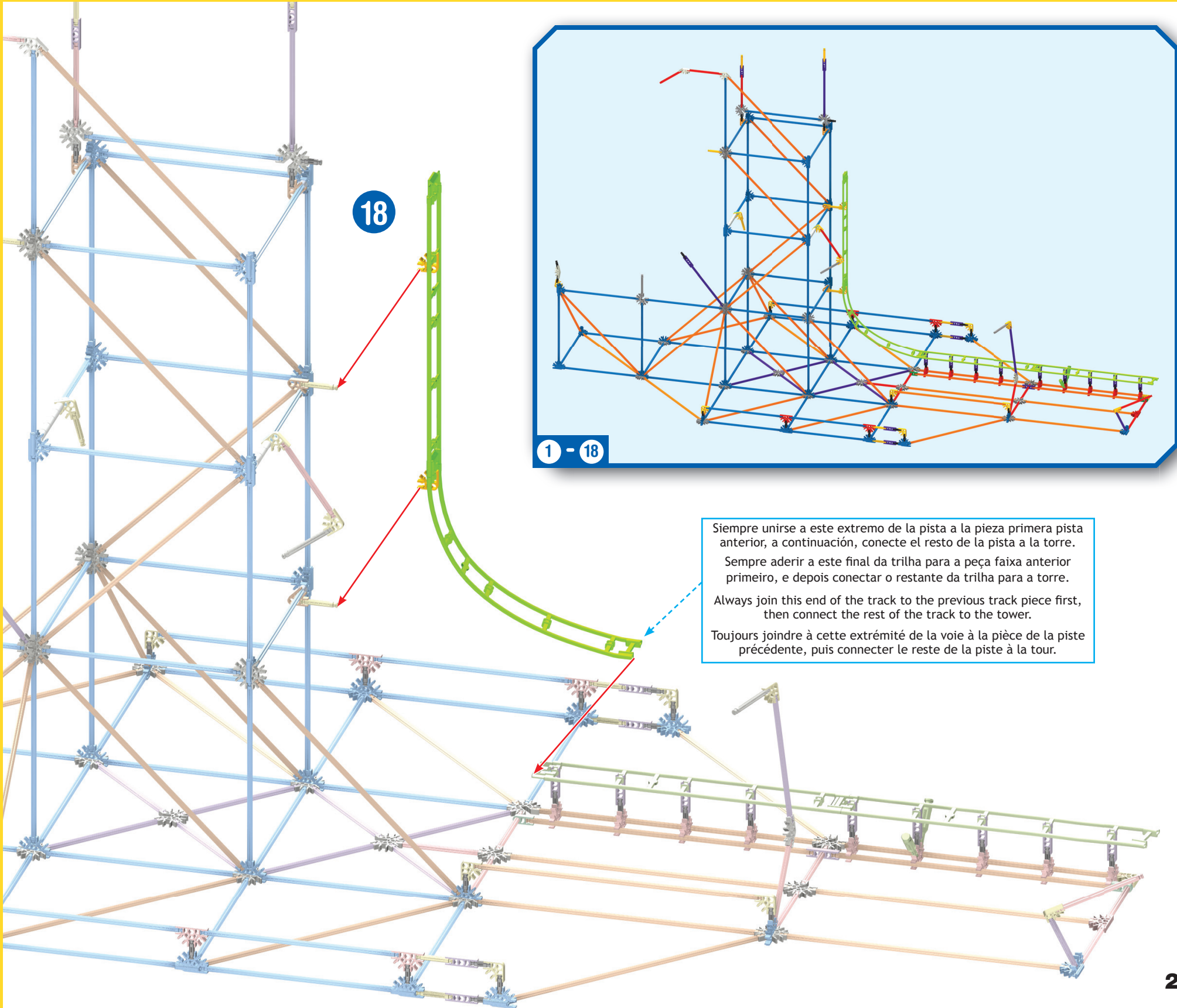

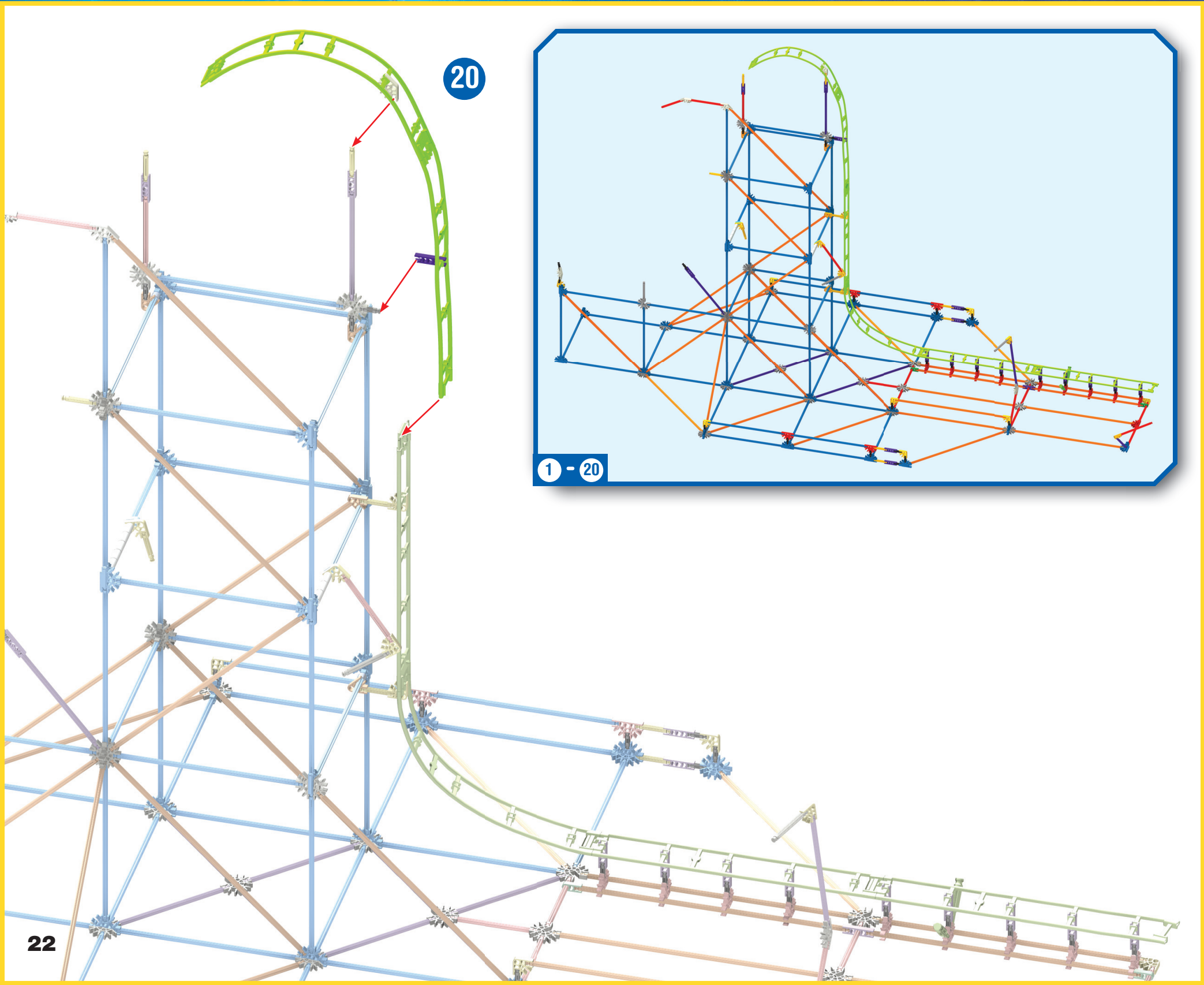
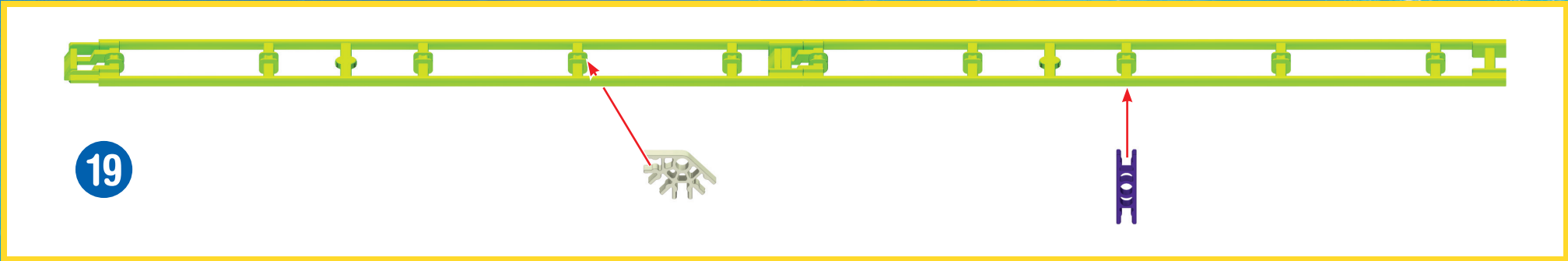

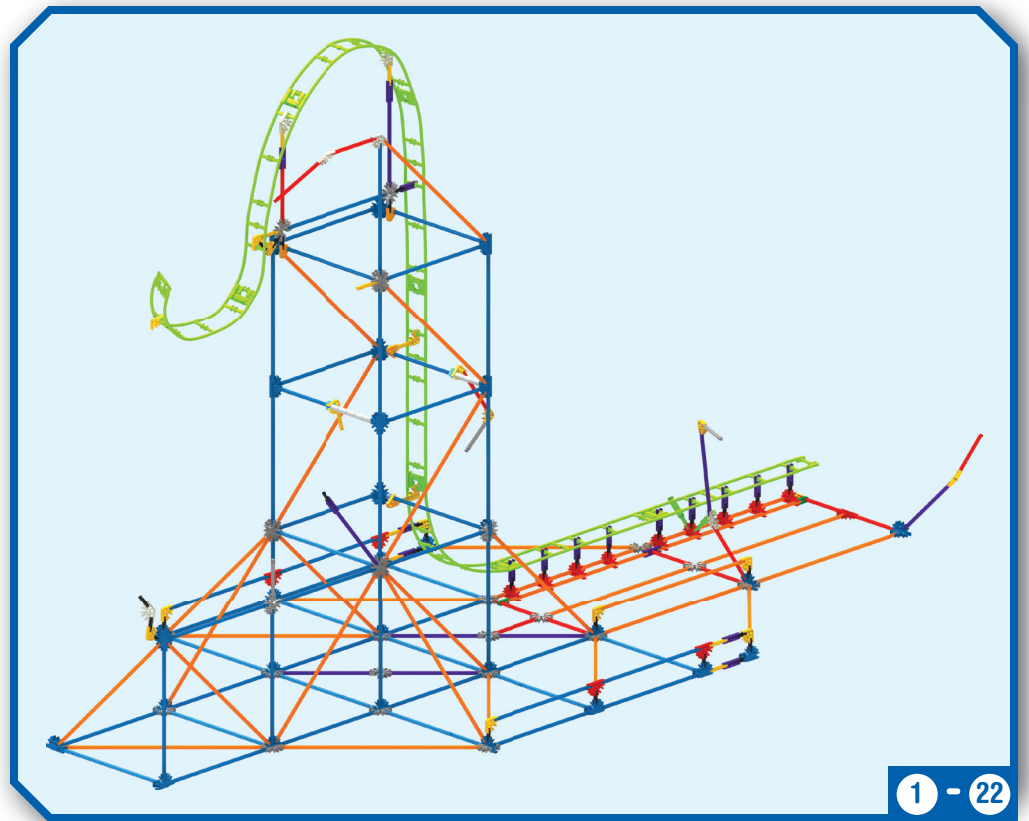
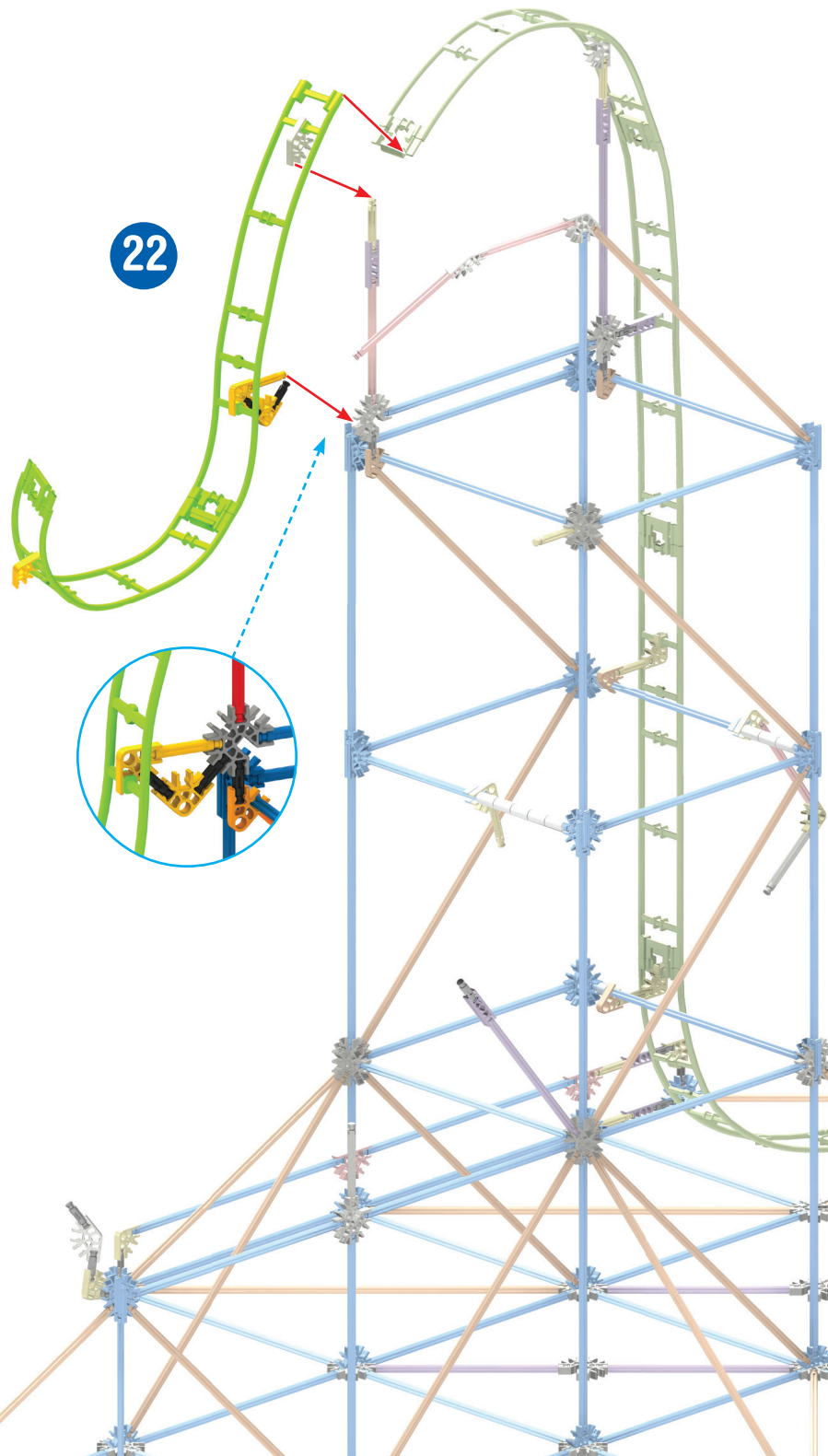

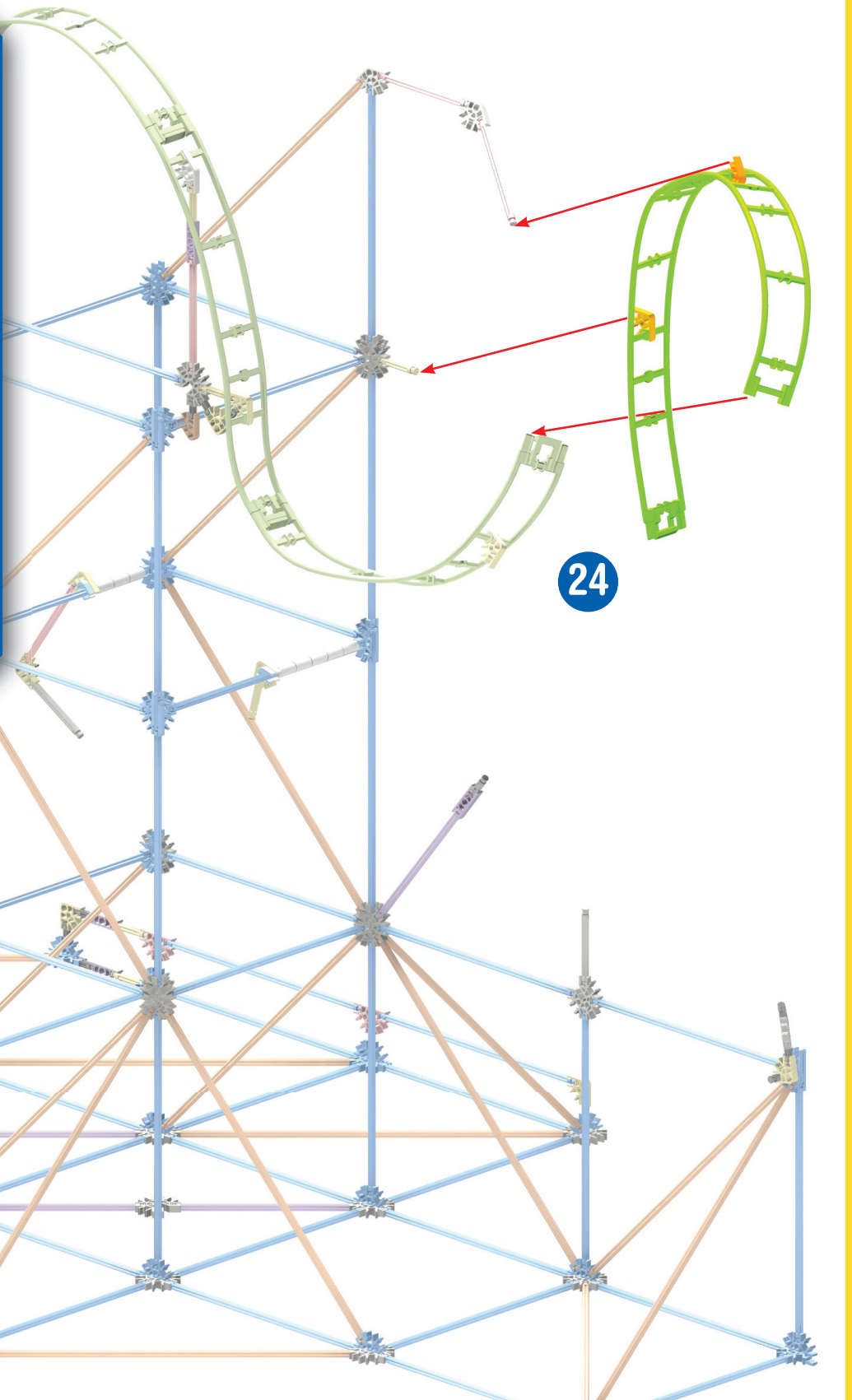
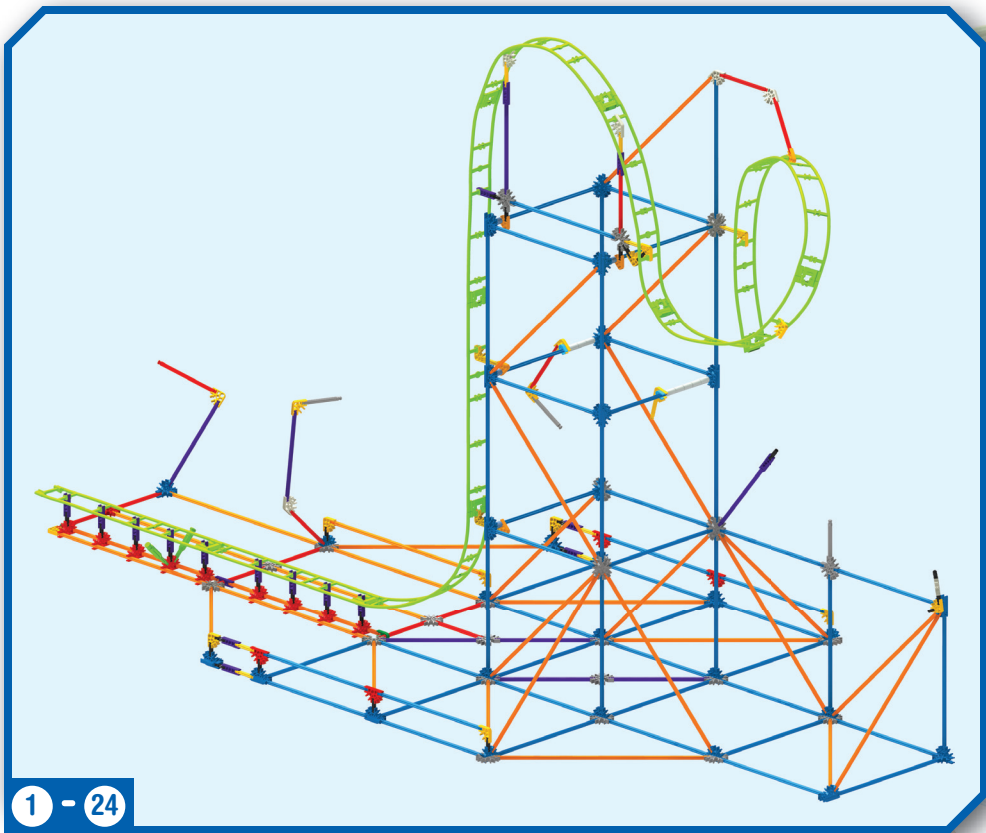
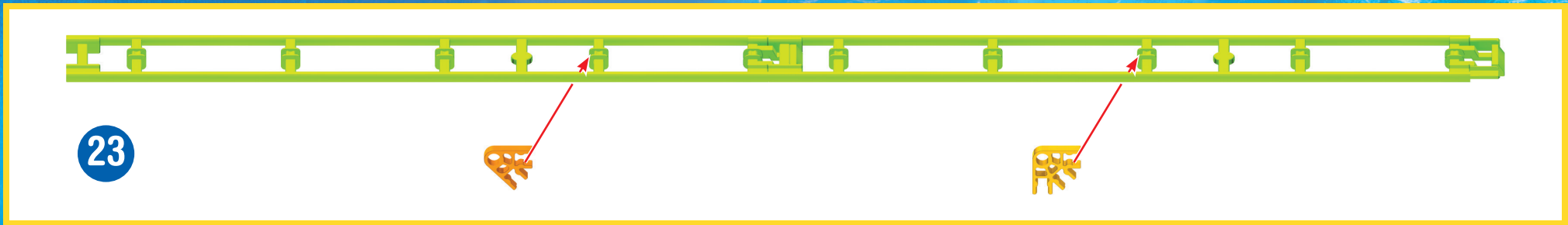



25

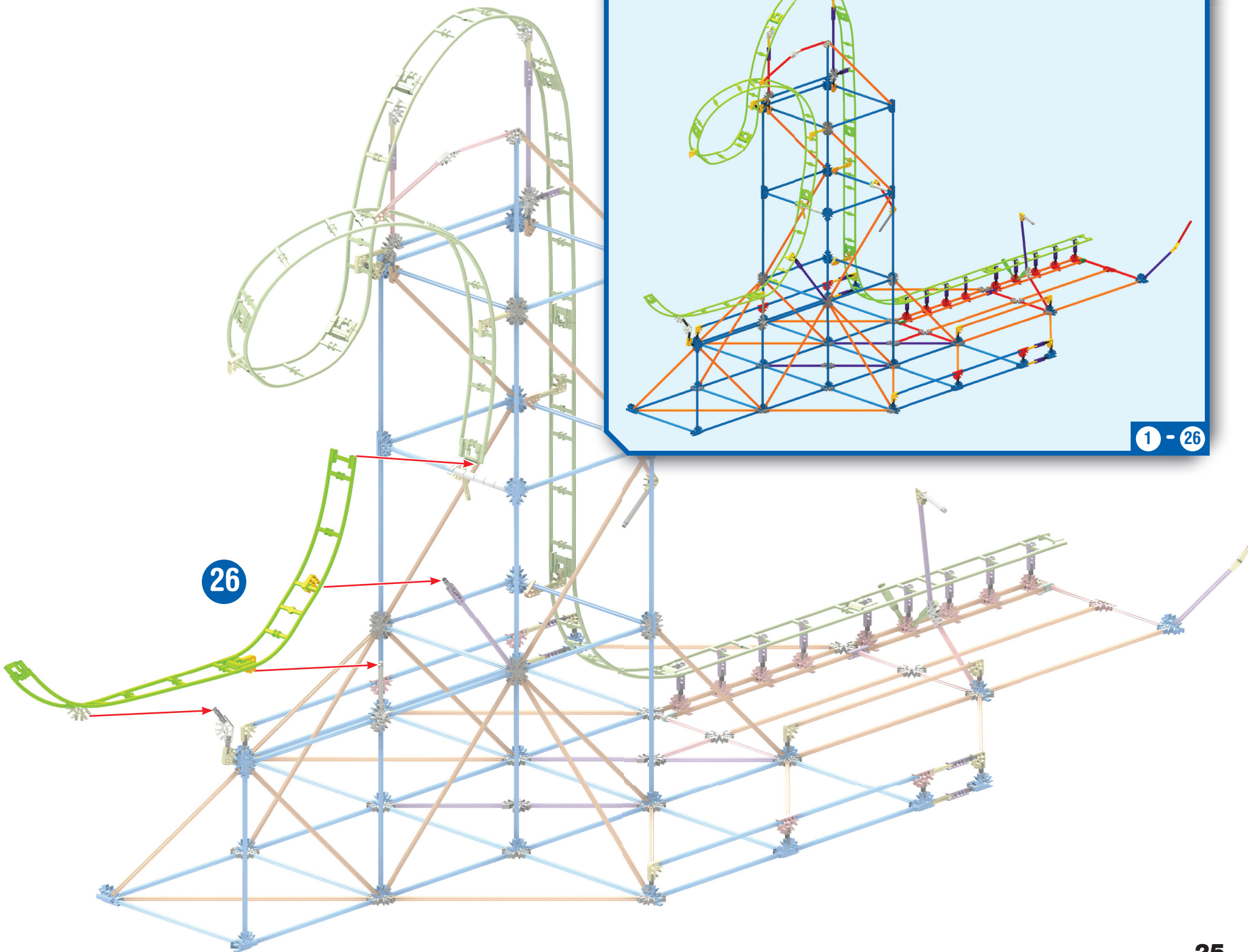
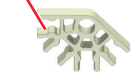

26

1 - 26

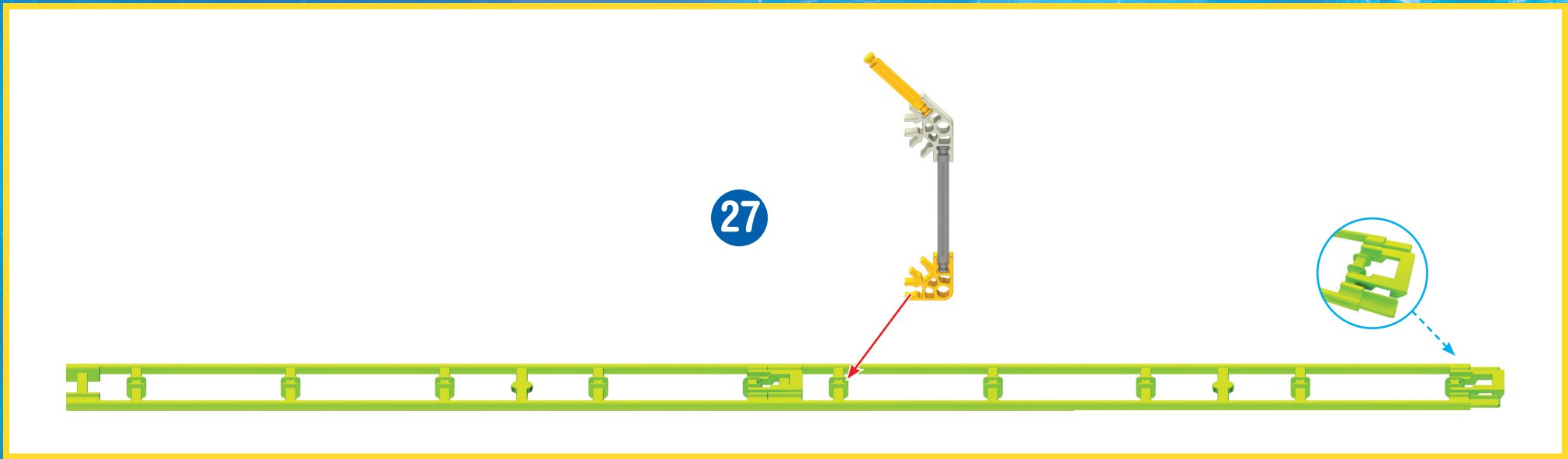

29

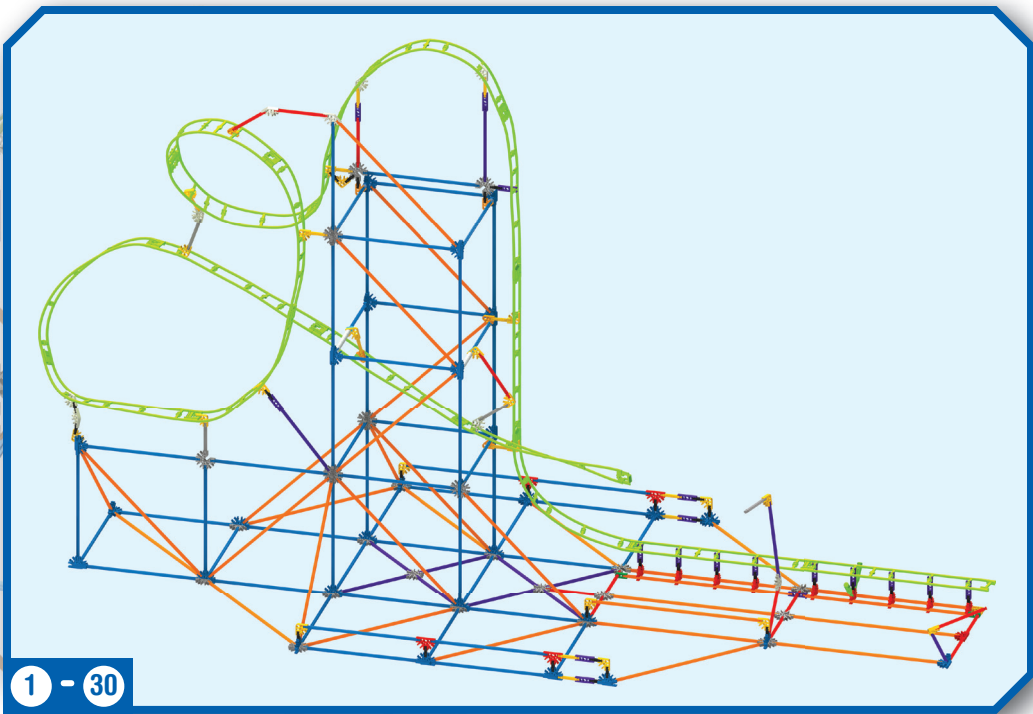
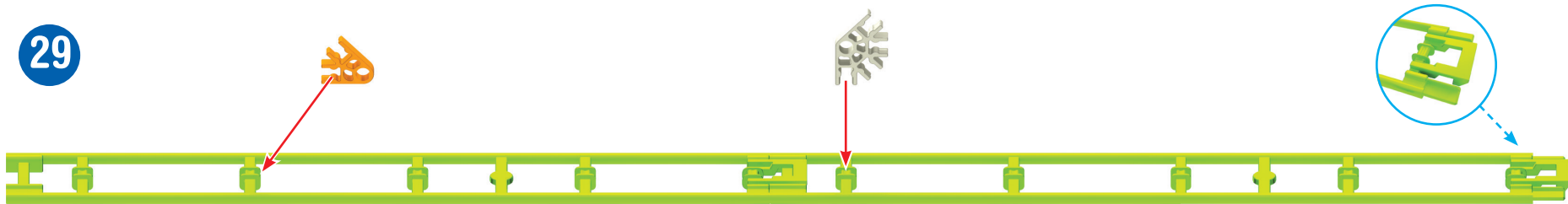

30

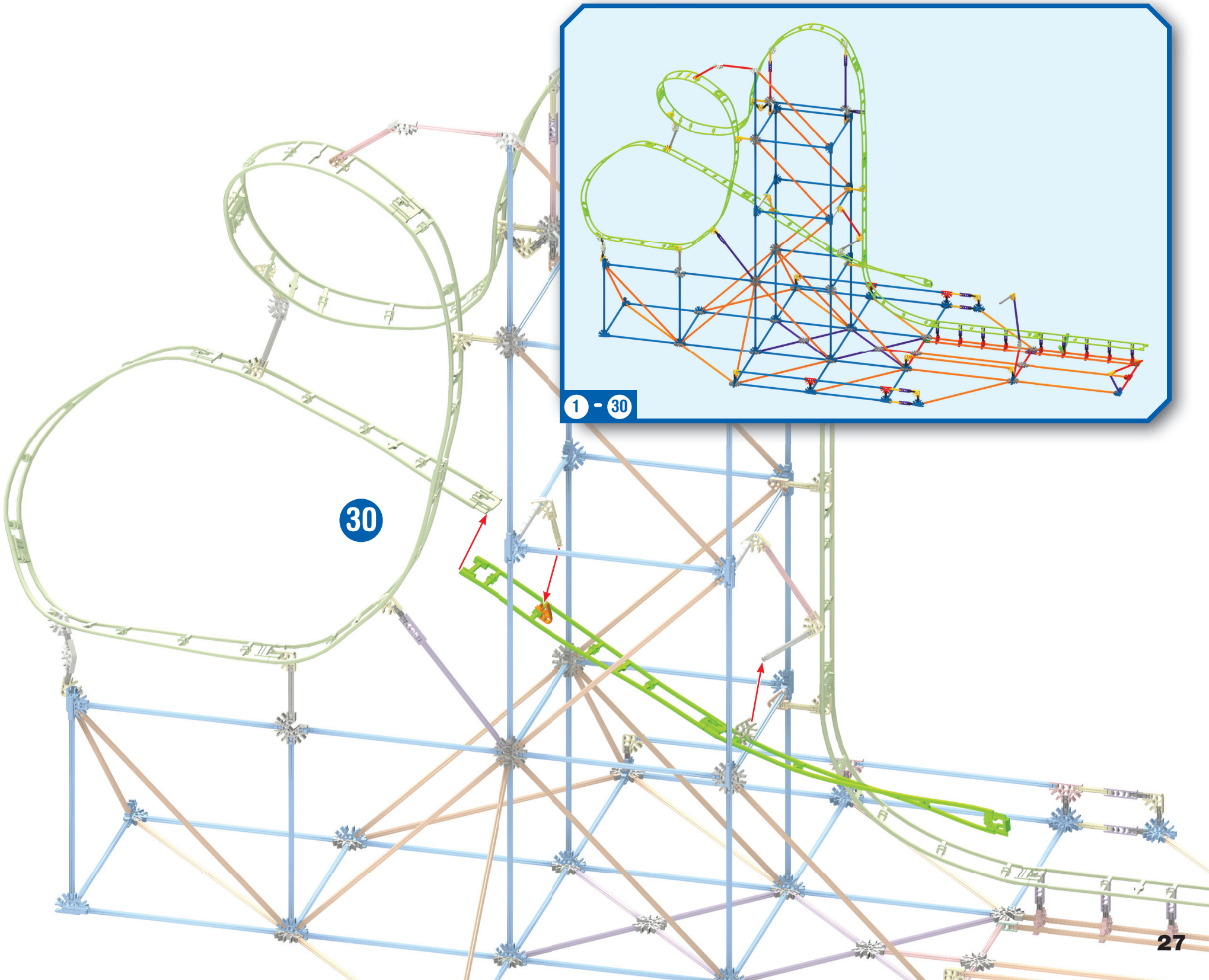

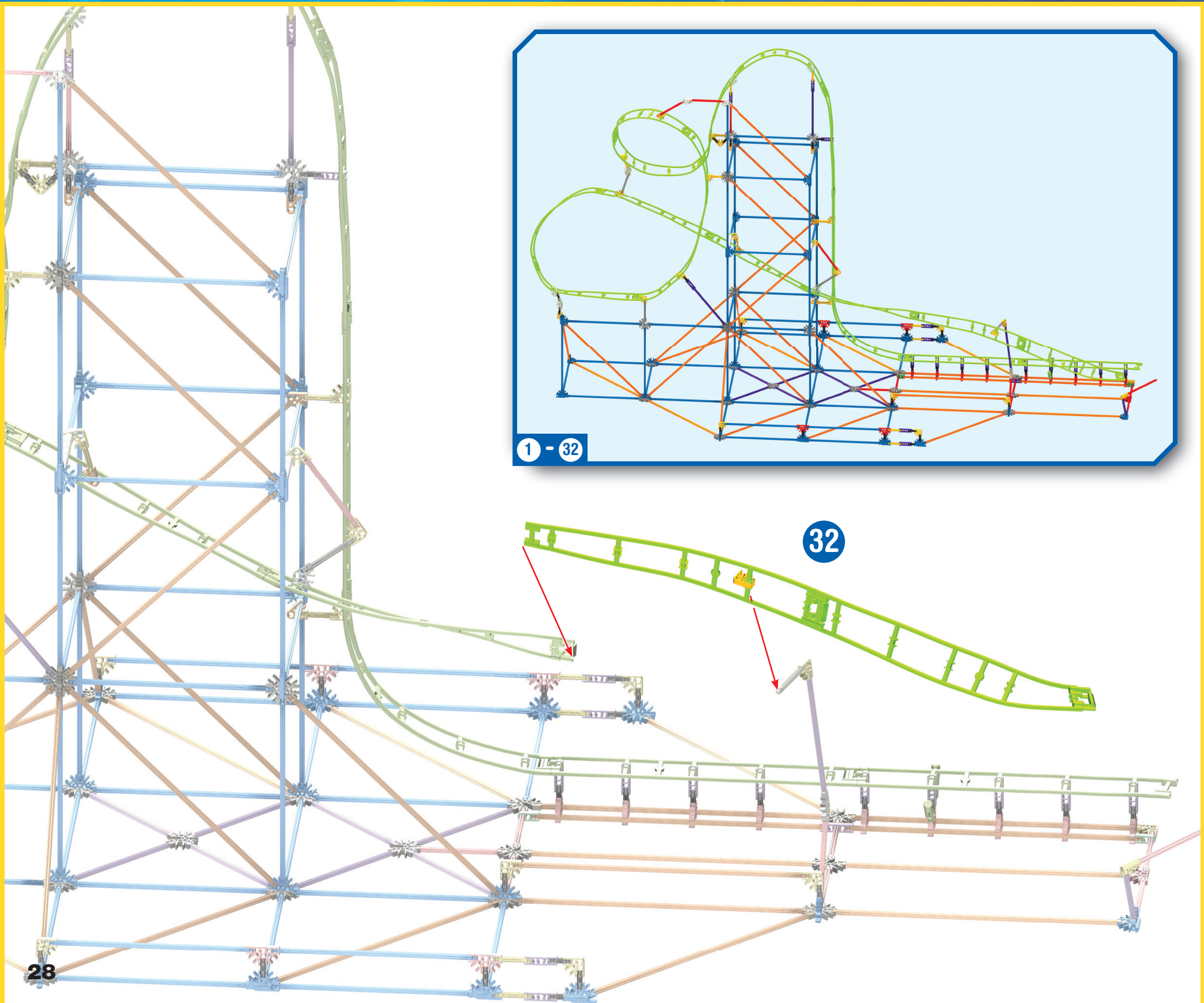
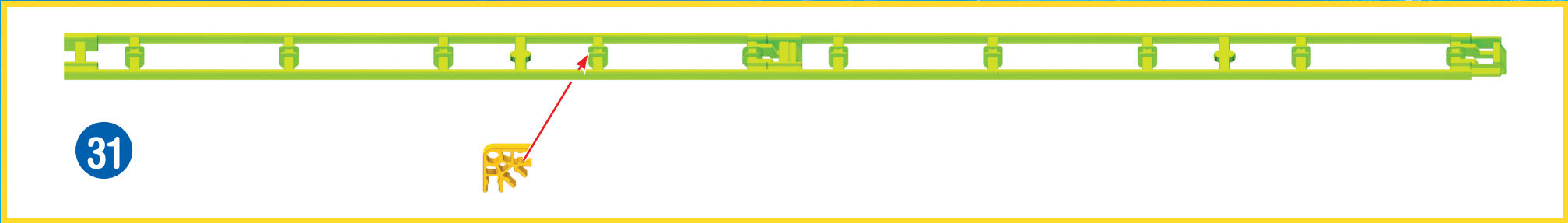

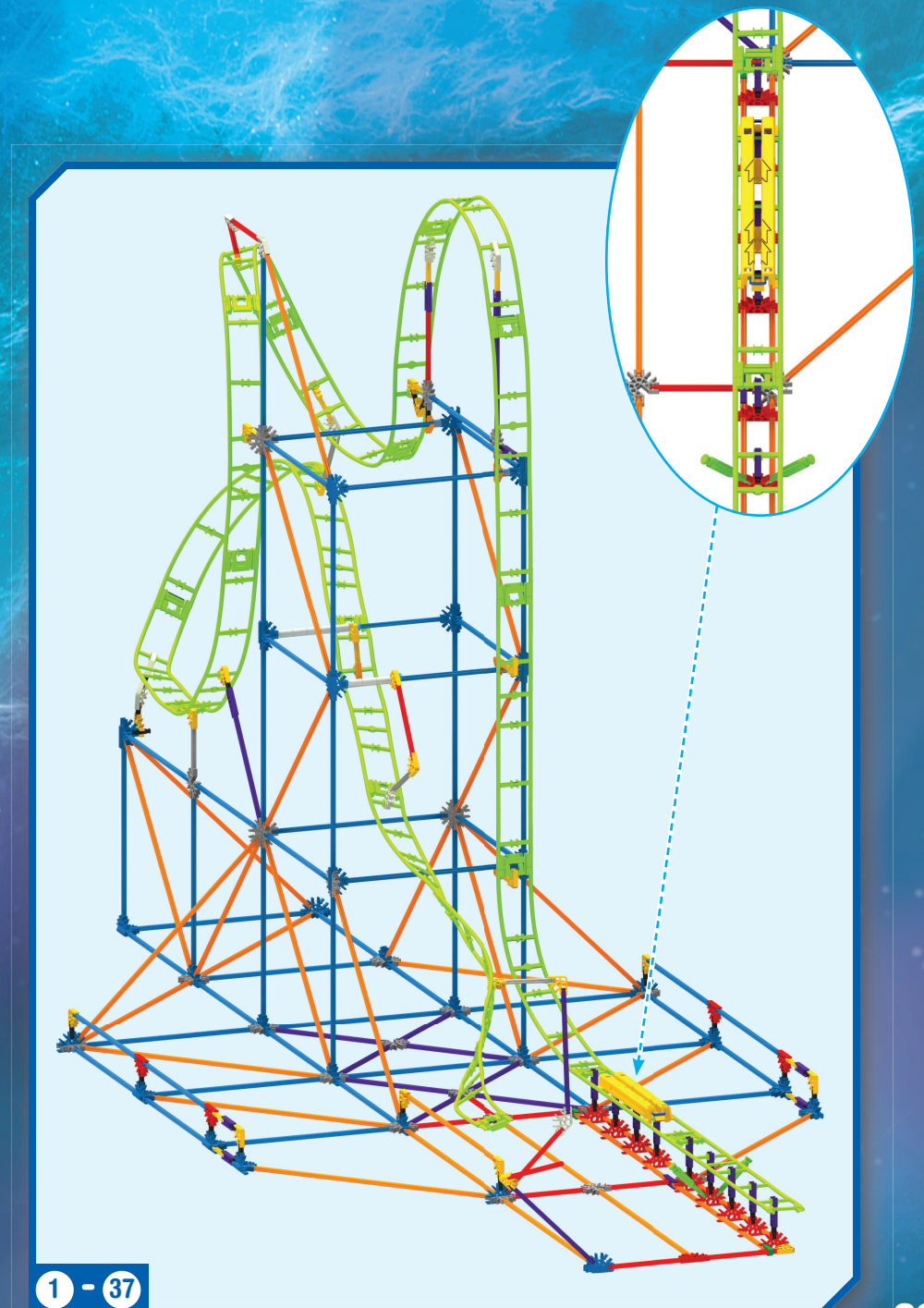
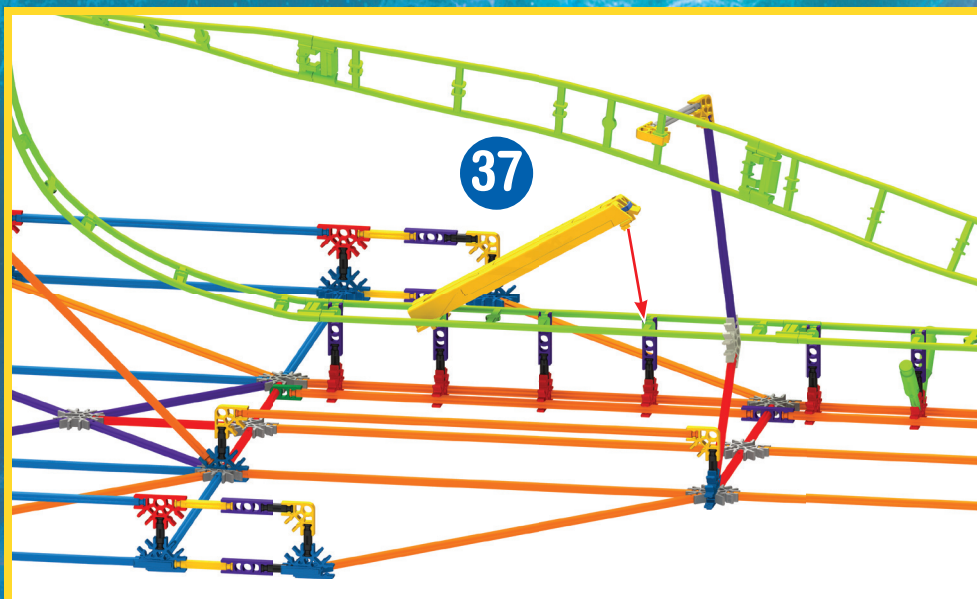
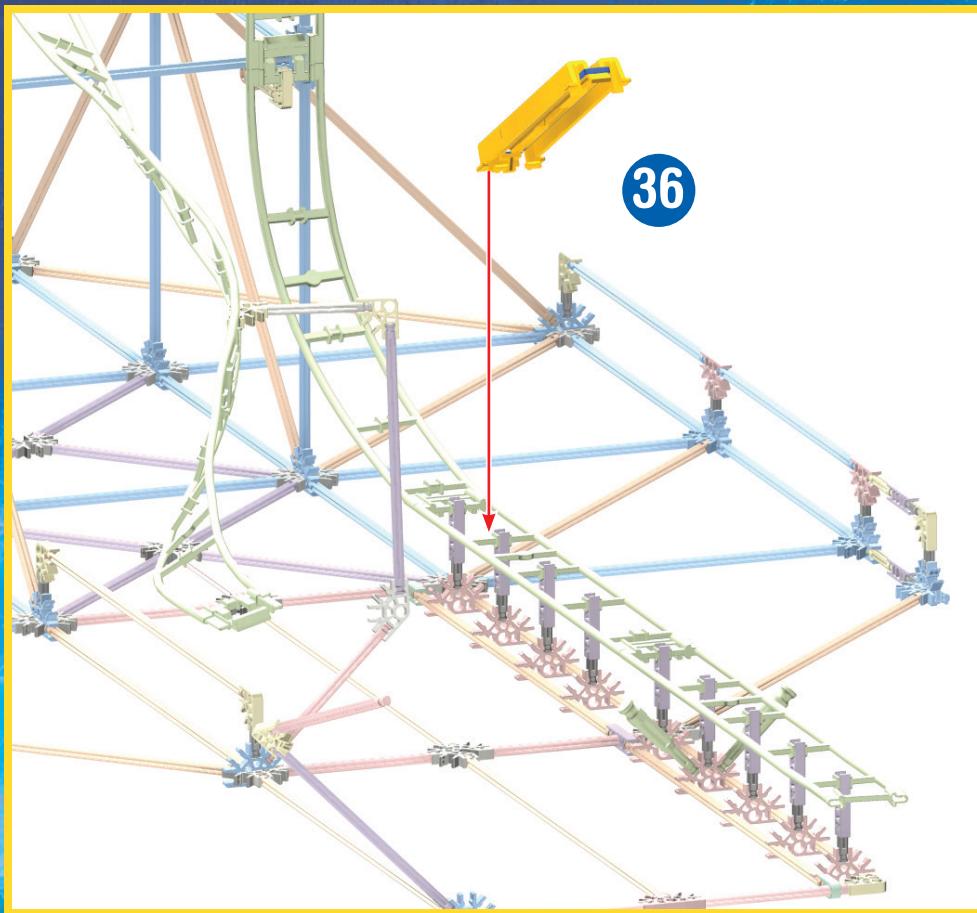
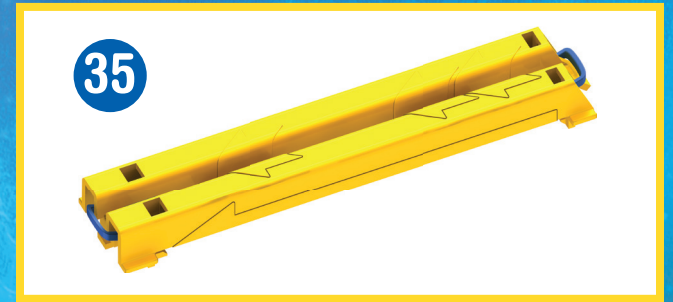
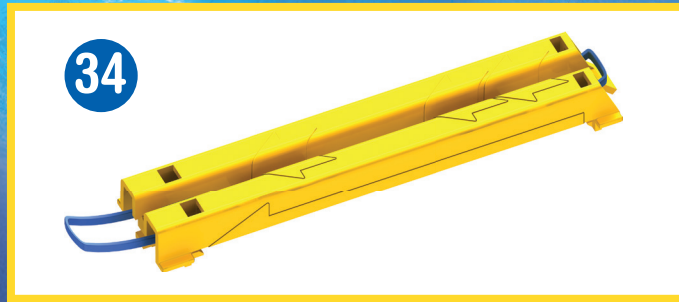

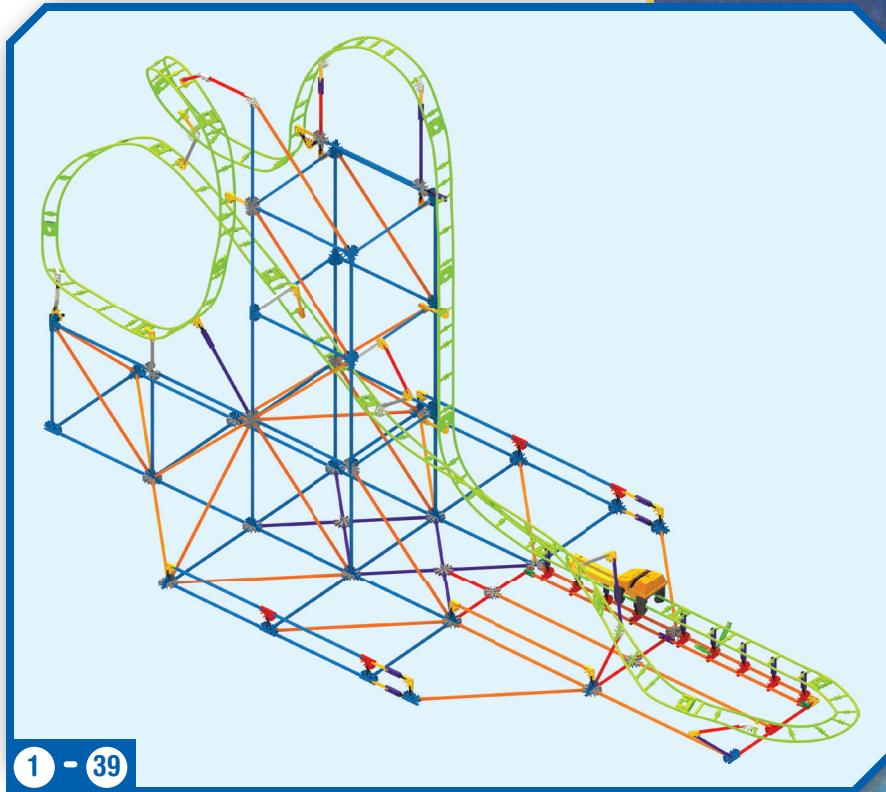
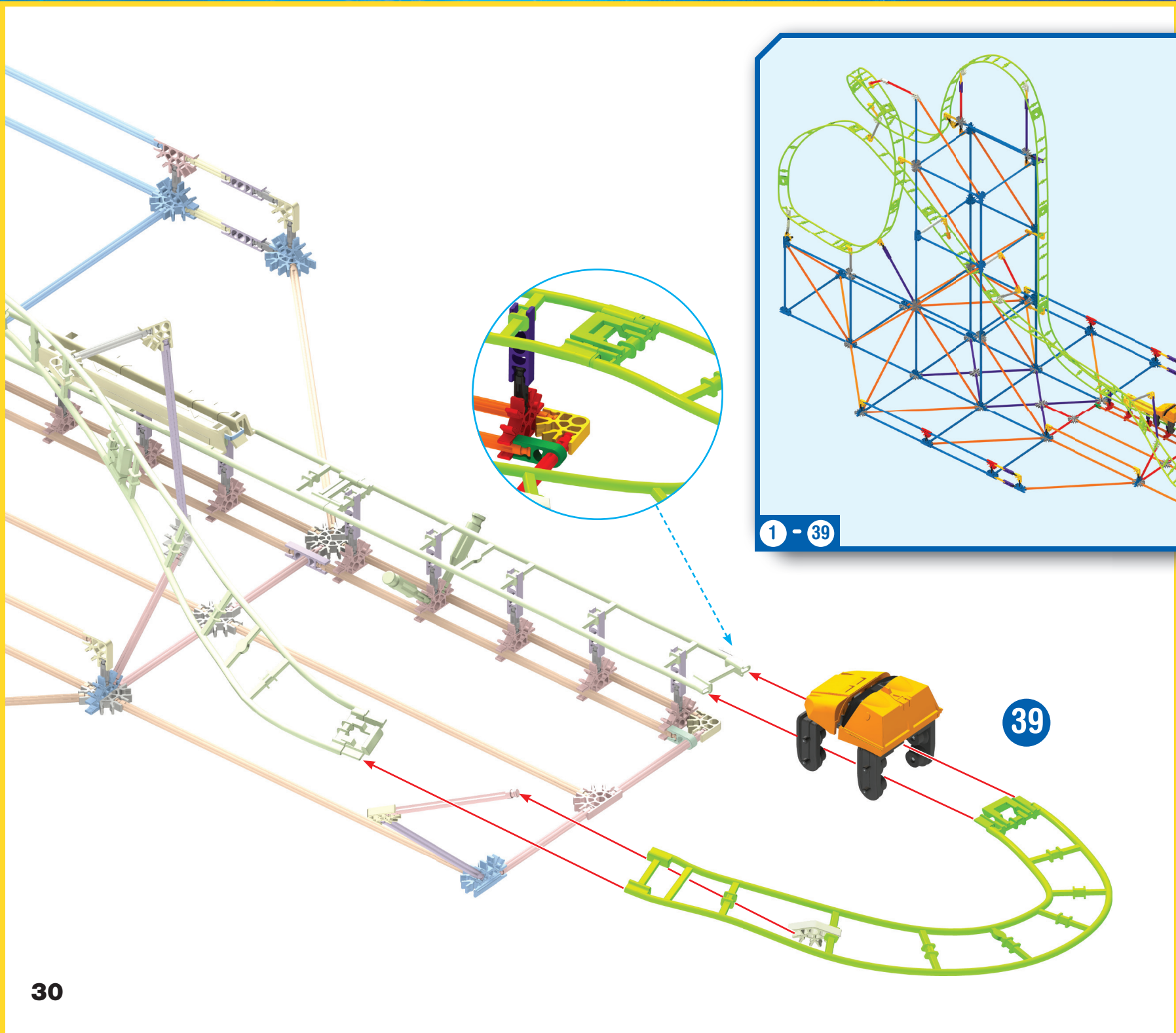
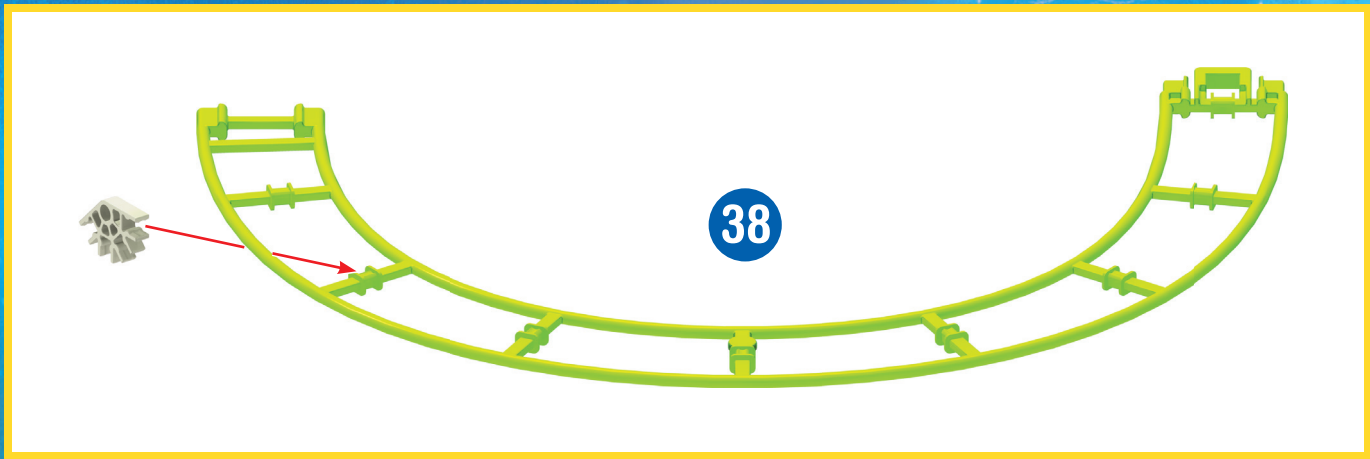

Cómo lanzar el vagón

Como lançar o carro

How to Launch Car

Lancement du wagon



- (ES) **A** Sostenga el modelo constante aquí.
B Tire del vagón hacia las varillas verdes y luego soltar.
 Mantenga las manos lejos de la pista en el lanzamiento.
- (PT) **A** Segure o modelo constante aqui.
B Puxe o carro de volta para as hastes verdes e solte.
 Mantenha suas mãos longe da pista quando do lançamento.
- (EN) **A** Hold the model steady here.
B Pull the car back to the green rods then release.
 Keep your hands away from the track when launching.
- (FR) **A** Maintenez le modèle d'équilibre ici.
B Tirez la voiture jusqu'au les tiges vertes puis relâchez.
 Gardez vos mains loin de la piste lors du lancement.



INFINITE JOURNEY
MONTAÑA RUSA
SET DE CONSTRUCCIÓN
INFINITE JOURNEY
MONTANHA RUSSA
SET DE CONSTRUÇÃO
INFINITE JOURNEY
ROLLER COASTER
BUILDING SET
VOYAGE INFINI
MONTAGNES RUSSES
JEU DE CONSTRUCTION

KNEX.COM



REVOLUTION
NORIA
SET DE CONSTRUCCIÓN
REVOLUTION
RODA-GIGANTE
SET DE CONSTRUÇÃO
REVOLUTION
FERRIS WHEEL
BUILDING SET
RÉVOLUTION
GRANDE ROUE
JEU DE CONSTRUCTION



CLOCK WORK
MONTAÑA RUSA
SET DE CONSTRUCCIÓN
CLOCK WORK
MONTANHA RUSSA
SET DE CONSTRUÇÃO
CLOCK WORK
ROLLER COASTER
BUILDING SET
HORLOGIE
MONTAGNES RUSSES
JEU DE CONSTRUCTION



§ Se venden por separado.
 Vendidos separadamente.
 Sold separately.
 Vendus séparément.

facebook.com/knex @knexbrands

www.fabricajuguetes.com

©2016 K'NEX Limited Partnership Group, P.O. Box 700, Hatfield, PA 19440-0700;
 1-800-KID-KNEX (USA/Canada/États-Unis/EE.UU.); email@knex.com; knex.com.
 K'NEX UK Ltd., P.O. Box 3083, Reading RG1 9YQ, England. For customers outside
 the USA/Canada please contact your local distributor at www.knex.com/distributors.

(ES) Para clientes fuera de EE.UU./Canadá póngase en contacto con el distribuidor
 local. Encuentre la información para el distribuidor local en www.knex.com/distributors

(PT) Para clientes fora de EUA/Canadá entre em contato com o distribuidor
 local. Encontrar informações para distribuidor local em www.knex.com/distributors

(FR) Pour les clients en dehors du Canada et des États-Unis, veuillez contacter
 votre distributeur local que vous pouvez trouver sur www.knex.com/distributors

(ES) K'NEX y Building Worlds Kids Love son marcas registradas de K'NEX Limited Partnership Group.
 (PT) K'NEX e Building Worlds Kids Love são marcas registradas da K'NEX Limited Partnership Group.
 (EN) K'NEX and Building Worlds Kids Love are registered trademarks of K'NEX Limited Partnership Group.
 (FR) K'NEX et Building Worlds Kids Love sont des marques déposées de K'NEX Limited Partnership Group.

(ES) El producto y los colores pueden variar. La mayoría de los modelos se pueden construir uno a la vez.
 (PT) O produto e as cores podem variar. A maioria dos modelos pode ser montado um de cada vez.
 (EN) Product & colors may vary. Most models can be built one at a time.
 (FR) Le produit et ses couleurs peuvent varier. Les différents modèles ne peuvent être construits qu'un par un.

Ensamblado y Distribuido por: / Montado e Distribuído por:
 Assembled and distributed by: / Assemblé et distribué par:

Fábrica de Juguetes S.L.U.

Avd. del Juguete s/n · apdo.125
 03440 IBI (Alicante) SPAIN

Guarde esta información para futuras referencias.
 Guarde esta informação para futuras referências.
 Save this information for future reference.
 Conservez ces informations à titre de référence.

Ref. 41211 - 15407 NC899/04/41211