

**K'NEXprint**

## Four-by-Fours

Most vehicles are controlled by either front or rear-wheel drive. Four-wheel drive vehicles, often called four-by-fours (4 x 4's), are built to give the driver freedom to travel on very rugged surfaces. They have powerful engines which provide the driver with control over all four wheels. This enhanced four-wheel control combined with heavy duty tires provides a safer ride on rough terrain. These sturdy and tough vehicles evolved from the jeep-like vehicles used by the military. While they can travel on all types of terrain, 4 x 4's are generally not designed for comfort but for utility and therefore tend to provide a bouncy ride. Although the K'NEX vehicle looks just like an average 4 x 4, when used with the motor, it operates by rear-wheel drive, not four-wheel drive.

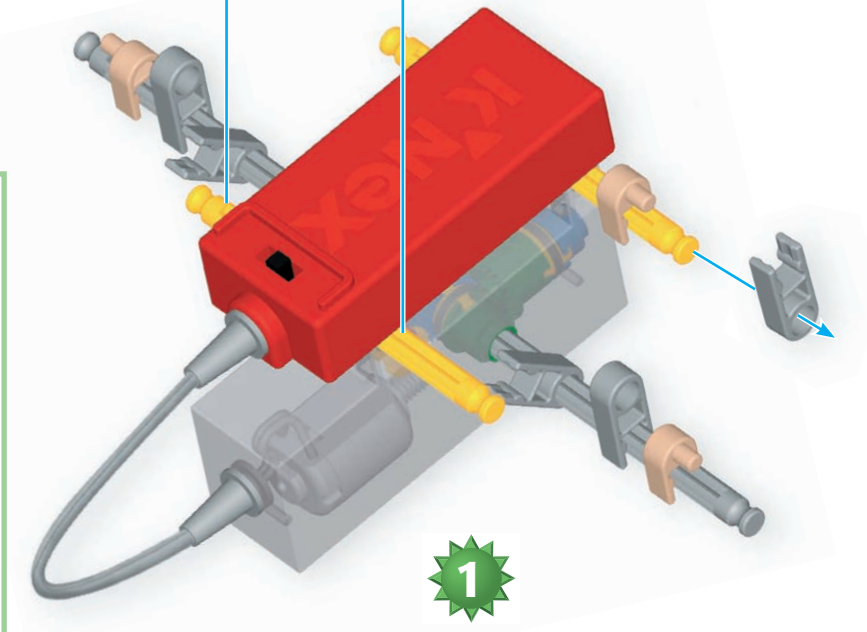

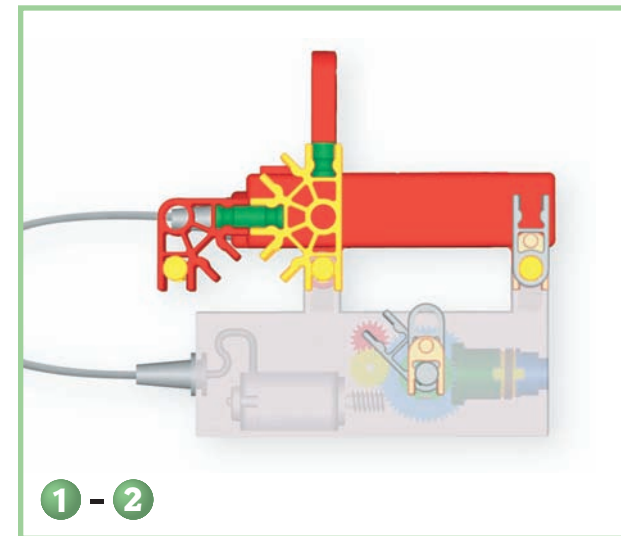









1	4	10	28
4	4	17	19
4	8	8	9
4	12	15	8
		5	2
			3



# Airboats & Hovercraft

The average boat cannot move through shallow water or water filled with weeds since the propeller and the hull could get caught on these obstacles below the water. Flat-bottomed airboats are driven through swamps by an above-water propeller. These boats are steered with a rudder positioned behind the propeller at the back of the airboat.

Hovercraft resemble airboats, but are not really boats at all. Powerful fans blow air behind the craft to move it forward; they also blow air underneath the craft into an air cushion on which they float above the surface of water or land.

2		9		8		17	
2		4		11		5	
7		6		12			
		20					

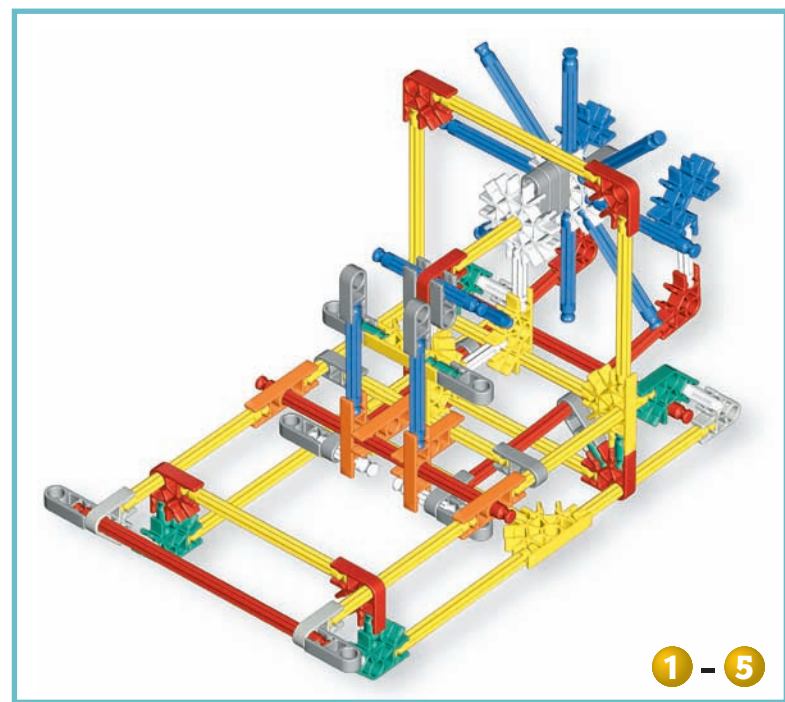
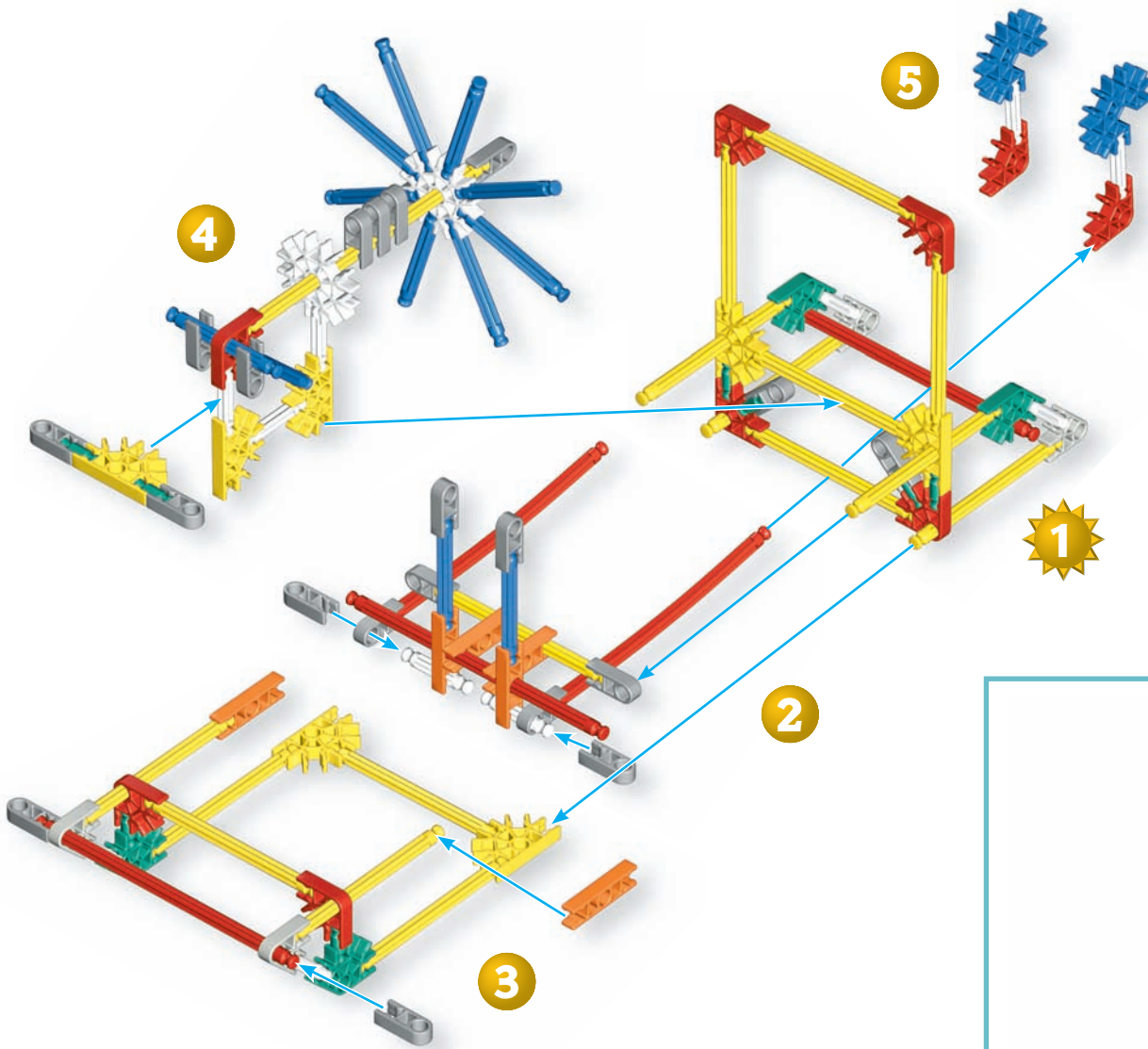

1 - 5

# Airplanes

The first motorized planes, developed in the early 20th century, were propeller driven and reached relatively slow speeds. They had to travel about 34 mph (55 km/h) on land to lift off. By contrast, today's Boeing 747 jet airplane must accelerate to 186 mph (300 km/h) to lift its own 385 tons. Once in flight it can travel up to 600 mph (968 km/h).

Both propeller (prop) and jet planes are used today but usually for different purposes. In many cases, propeller planes are more efficient and easier to maneuver than jets and are appropriate to use at low altitudes, for light loads, short flights and special hard to reach areas where there are few roads and rails and little or no runway.

Wing flaps called ailerons help pilots control the plane. These are raised or lowered individually or together for turning (banking) in flight. Other flaps provide lift for takeoff and landing. An elevator and rudder also provide the pilot with additional control for ascent, descent and banking.

8		2		2		12	
2		6		2		4	
14		4		9		5	
		5		7		4	

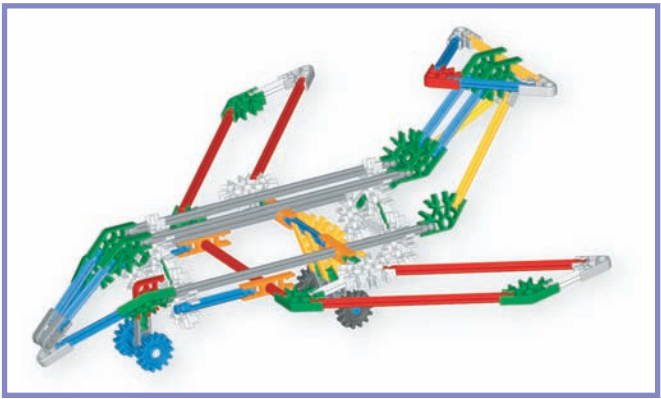

2

1

3

4

5

6

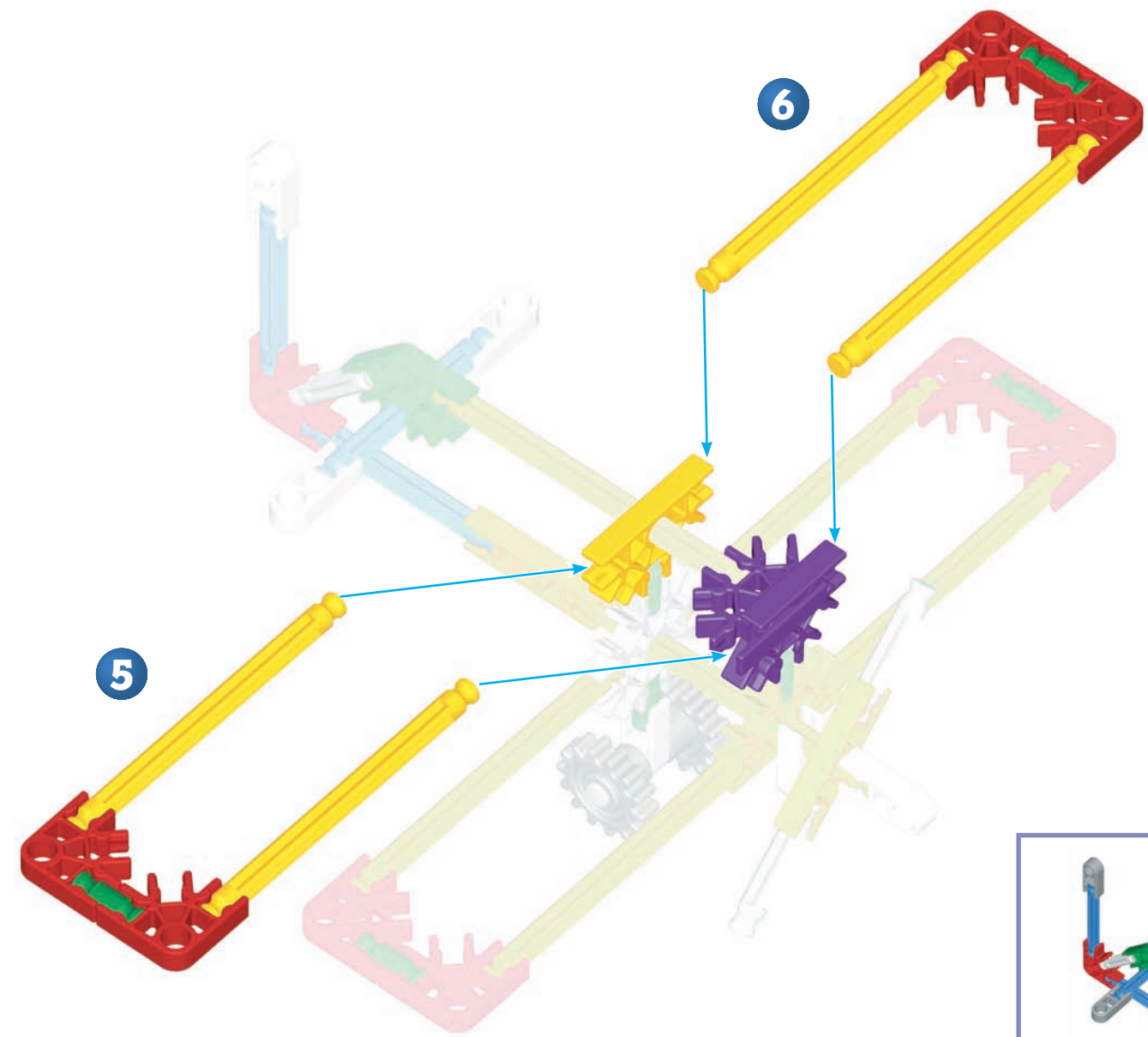
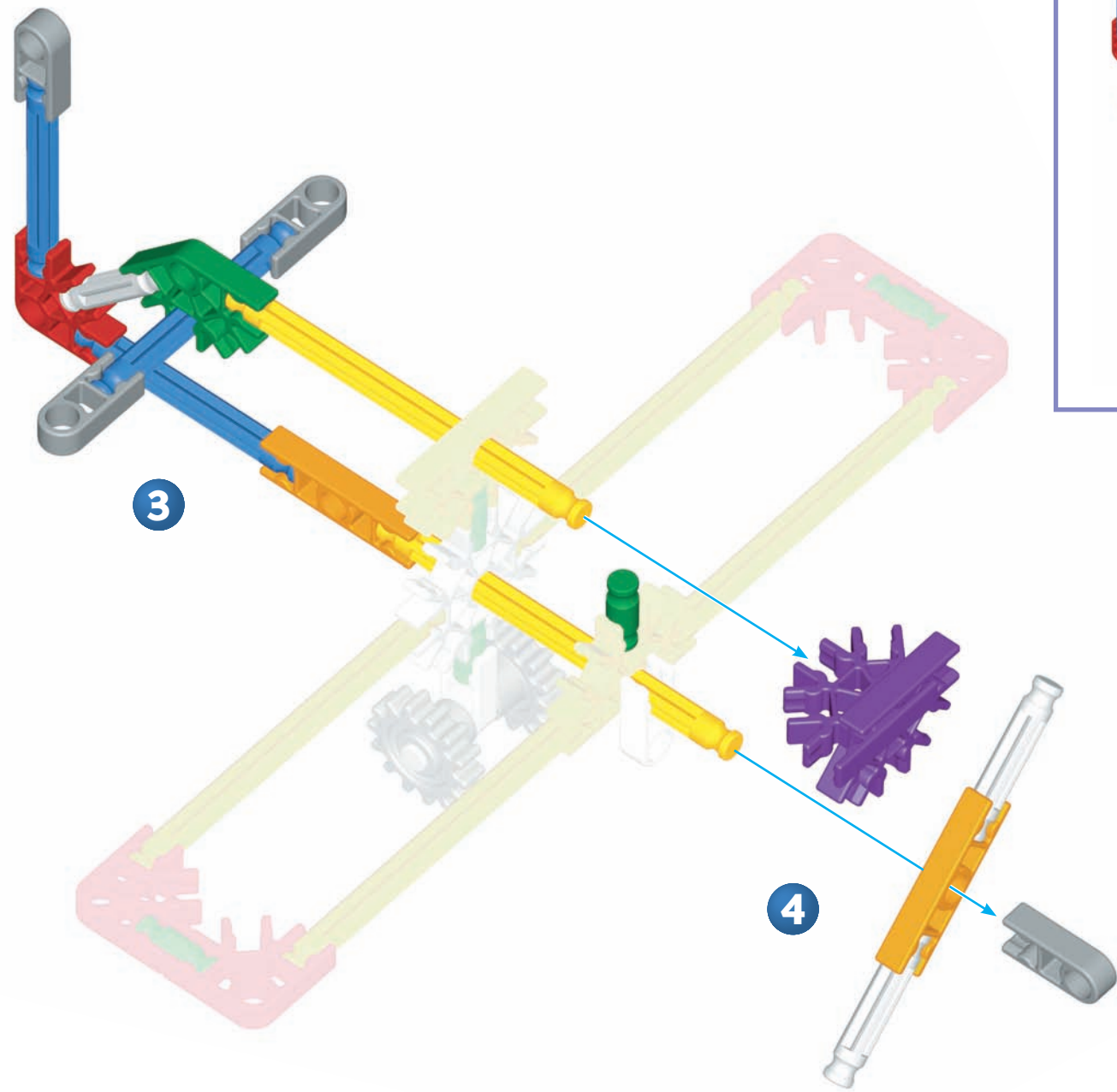

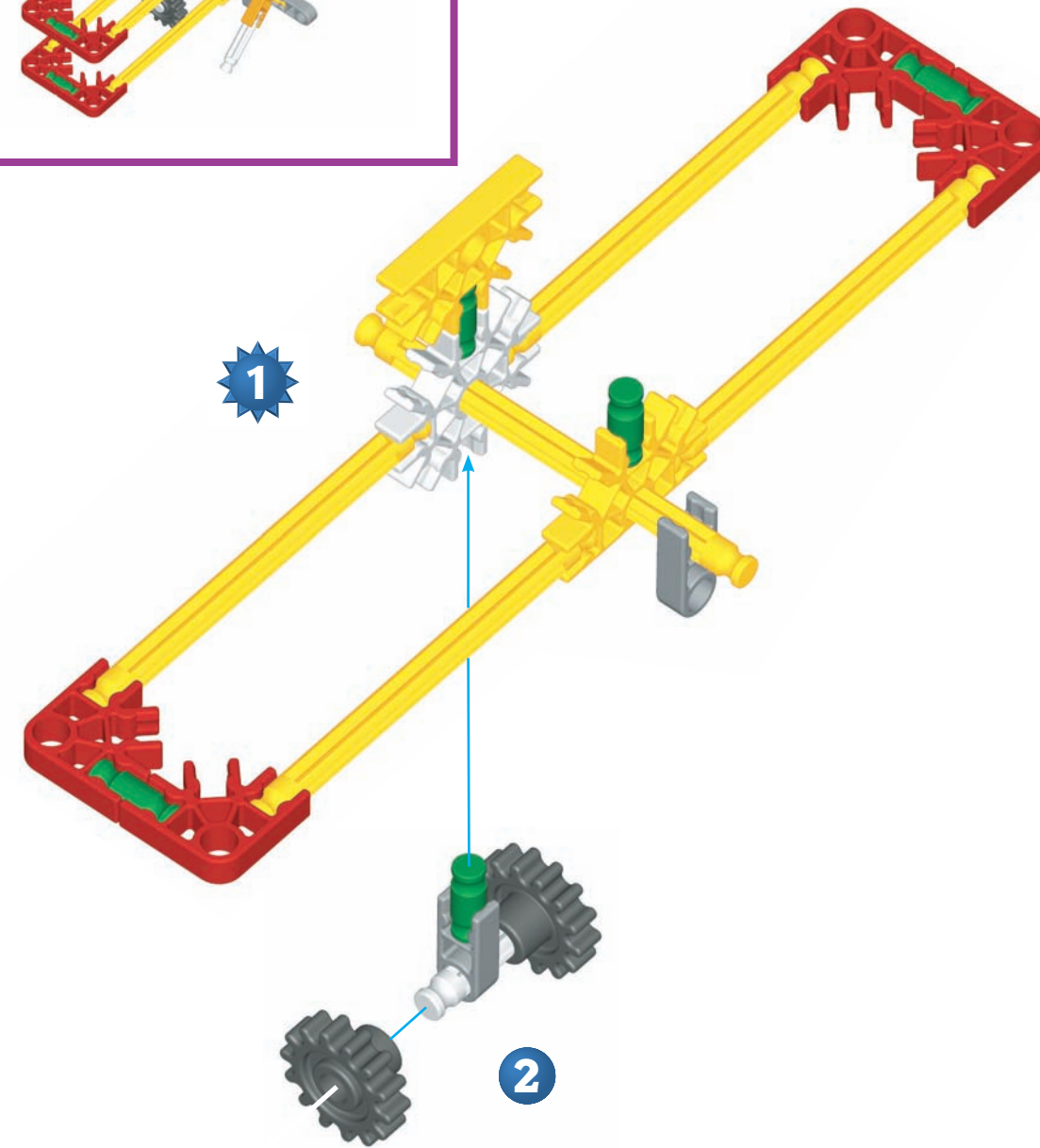
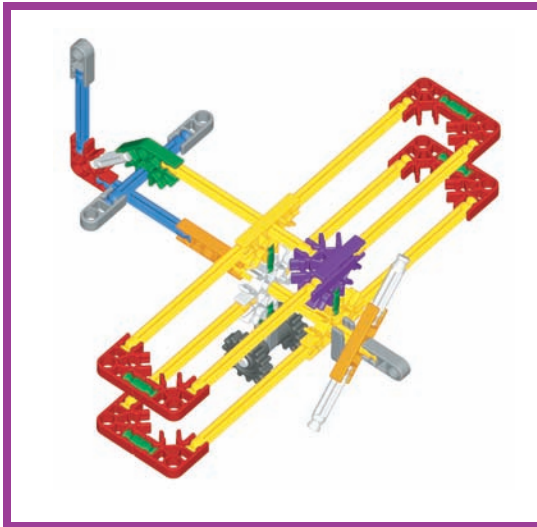
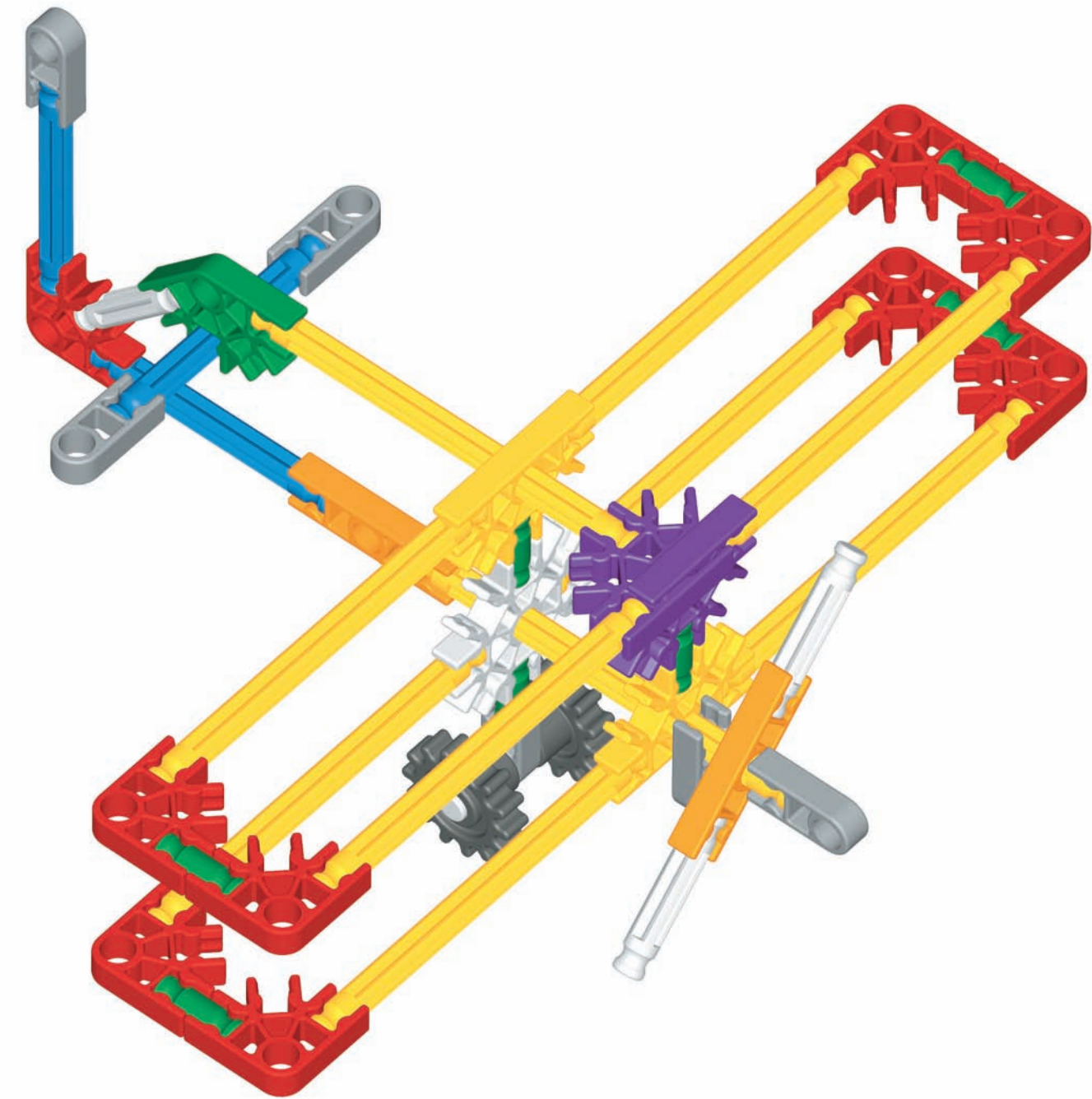













K'NEXprint

## Biplanes

An airplane is a heavier-than-air vehicle designed to be supported by the air. Wings are attached to the main body or fuselage of a plane and help provide lift by creating different air pressures above and below the wing as the plane travels. Instead of constantly fighting air currents, wings provide the ability to take advantage of them. Early years of flight were marked by planes with several pair of wings – biplanes with two pair and triplanes with three pair – which often made the planes appear to be all wing.

The first powered airplane was built by Orville and Wilbur Wright. These two brothers from Ohio designed a glider and decided an engine would make it fly better. They built their own 12-horsepower motor and after years of experiments, they launched their plane on December 17, 1903 at Kitty Hawk, North Carolina. The first flight lasted three seconds and their second flight covered 120 feet (37 meters) in twelve seconds.

1 	2 	2 	6 	3 
2 	1 	2 	7 	10 
9 			4 	

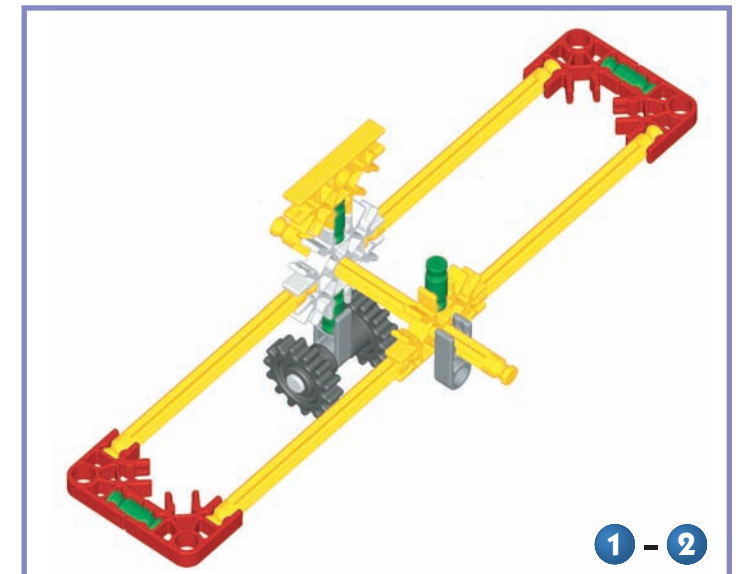













96322-27

# Airships: Blimps and Dirigibles

Today's airships consist of an envelope containing helium which allows them to rise and float, and a gondola filled with all the instruments and controls where the crew and passengers travel. Used for photography, film making, advertising and scientific research, these blimps even patrol coastal waters and haul cargo. The Goodyear Blimp provided emergency information and instructions after Hurricane Andrew in 1992.

Airships are able to stop in midair, hover (stay in place) for very long periods and travel in reverse; they also require limited fuel. Turbo prop engines assist their takeoff and landing, and propel them along. The crew steers the airship by using rudders on the forward portion of its body and rudders/elevators on its tail which tilt the nose up, down, left and right.

6		36	
34		10	
10		22	
4		17	
8		17	
15			
21			

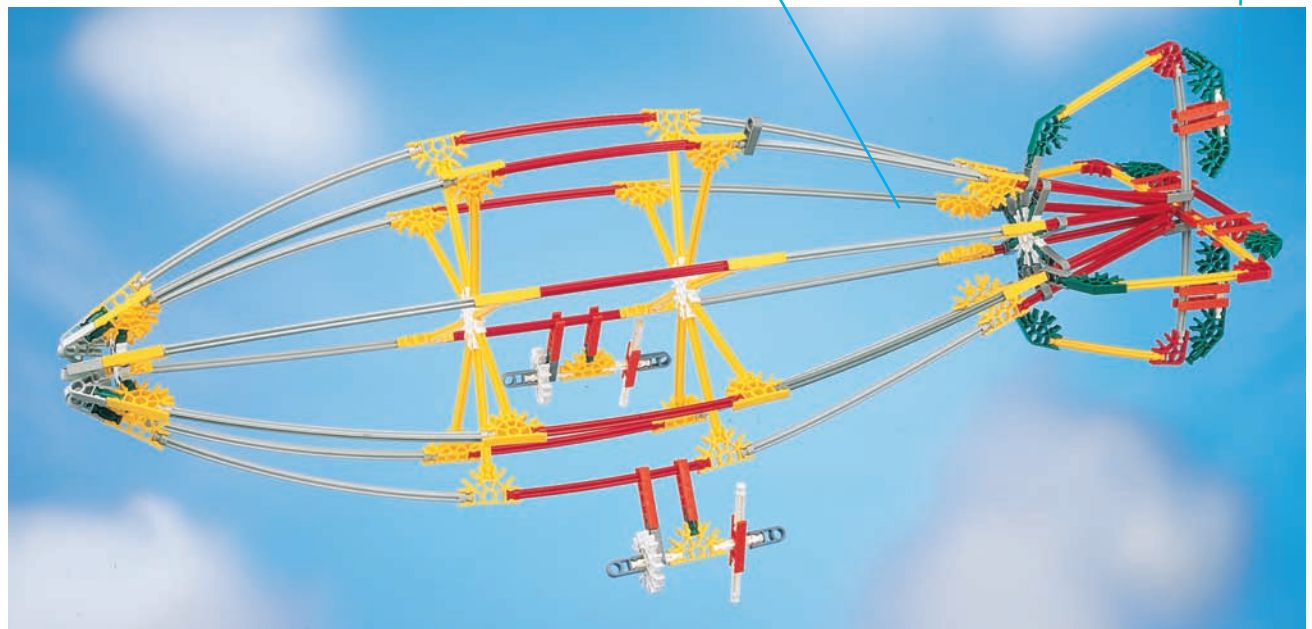
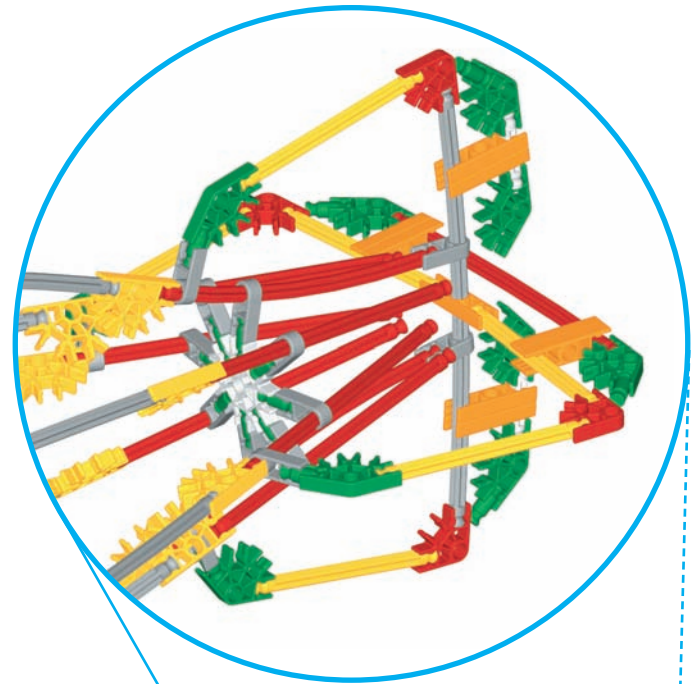
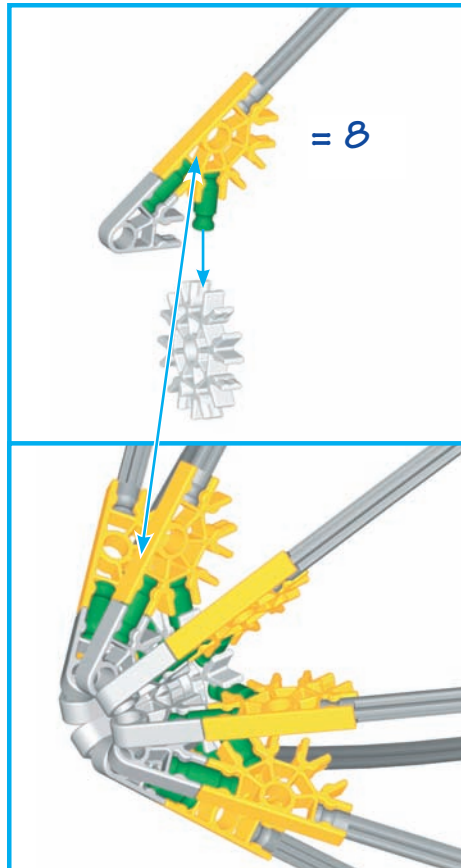

## Dirigibles and Zeppelins

The idea of making a balloon from lightweight materials and filling it with hydrogen gas became a reality by the mid 1700's. New designs, pioneered by Ferdinand von Zeppelin, increased the use of these vehicles for travel and transporting cargo during the late 1800's and early 1900's. They lost their popularity after several catastrophic hydrogen explosions between World Wars I and II.

Today the airship is being granted another life as designers and engineers work on new designs. One of these, the Skyship, resembles a flying saucer. It can haul 400 tons of cargo, travel 100 mph (160 km/h) and carry 24 crew members. Expect to see these redesigned airships gain popularity for transportation and recreation by the year 2000.

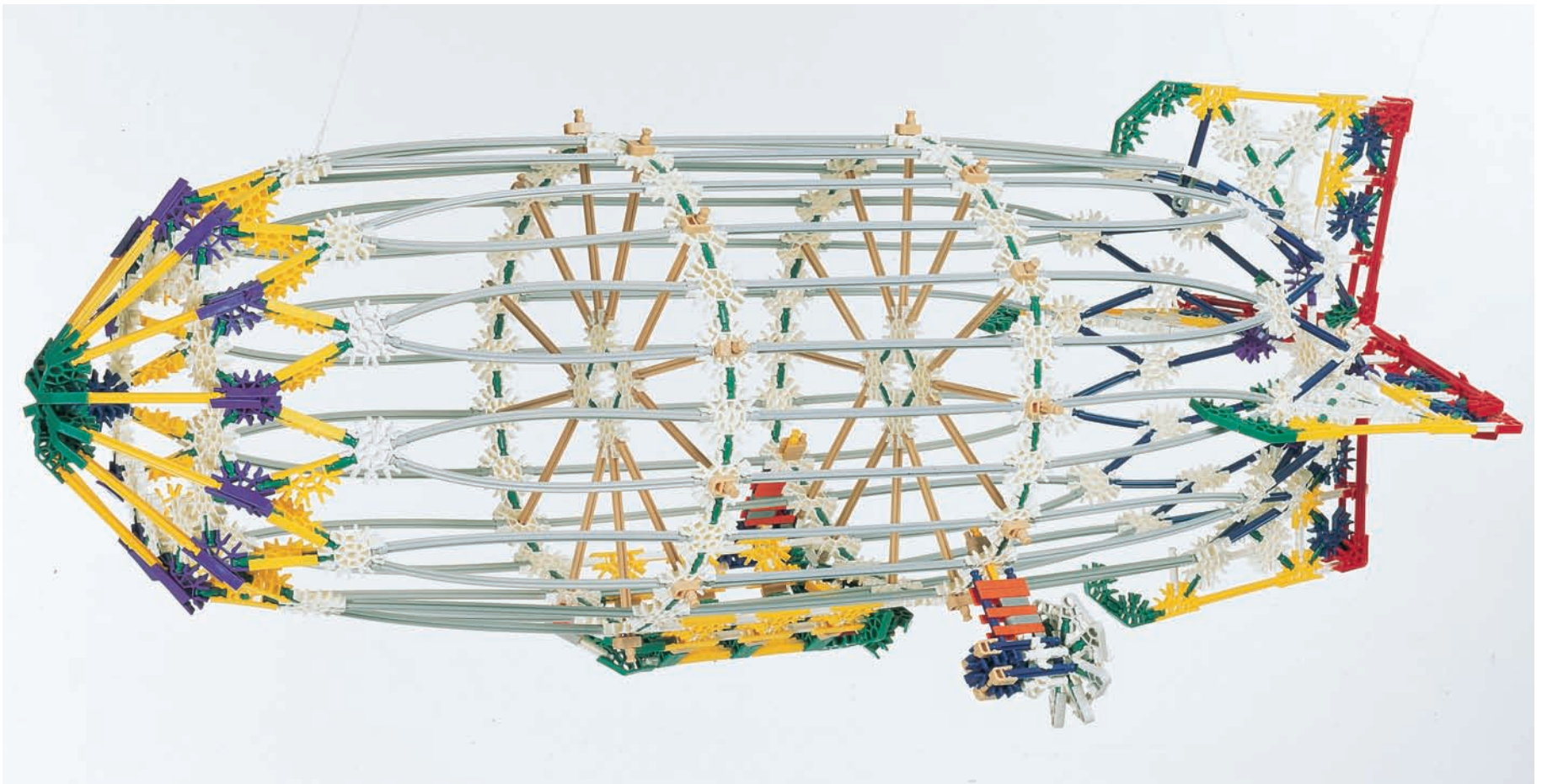

# Horses

Animals have been a vital means of transportation for thousands of years because they were the only means available other than travel by foot. However, they remained popular over time because they do not need expensive, dirty fuels for power--just food. Horses, donkeys, mules, camels and elephants are among the most common animals used for transportation.

Horses are used mostly by ranchers, especially in North and South America, Australia and Asia. They can run at speeds up to 40 mph (65 km/h) and work well with other animals. They have served a variety of purposes throughout American history and were important as the early settlers explored new terrain and pioneers spread westward during the expansion of the U.S. Wars were even fought on horseback. Throughout history, and even today, horses continue to play an important part in farming, hunting, travel and sport in the U.S. and around the world.



## Buses

Buses are the most popular and least expensive means of public transportation in the U.S., transporting millions of people to work, school, shopping and other destinations. They hold up to 70 passengers and their big windows let people see the outdoor scenery as they ride. Some buses, used for long-distance travel, have a bathroom and luggage compartment.

Early buses were trucks made suitable for passengers. Today, they are stream-lined, fuel-efficient and comfortable. Many city buses include wheelchair lifts to accommodate the physically challenged. In some parts of the world, double decker buses are very popular for sightseeing and daily travel. In the U.S., buses today can be designed to accept additional sections of bus to transport more riders.



# Catamarans

The catamaran is a very wide boat with two hulls that can carry a lot of sail. This makes it an exceptionally fast type of sailboat, as well as being fun and relatively easy to master. The number of hulls enhances the stability of a boat or ship in the water, particularly under the effects of wind and rough water. Trimarans, with three hulls, are even more stable than two-hulled catamarans. This boat originated as a raft which was developed for carrying cargo in Indian and Indonesian waters—it was also used to travel long distances. The world's largest catamaran today is the Hover Speed Great Britain Sea Cat with a top speed of 42 knots (36.5 mph).

5		10		35		4	
6		10		20		9	
19		4		20		6	
8		9		10		4	
2		11					

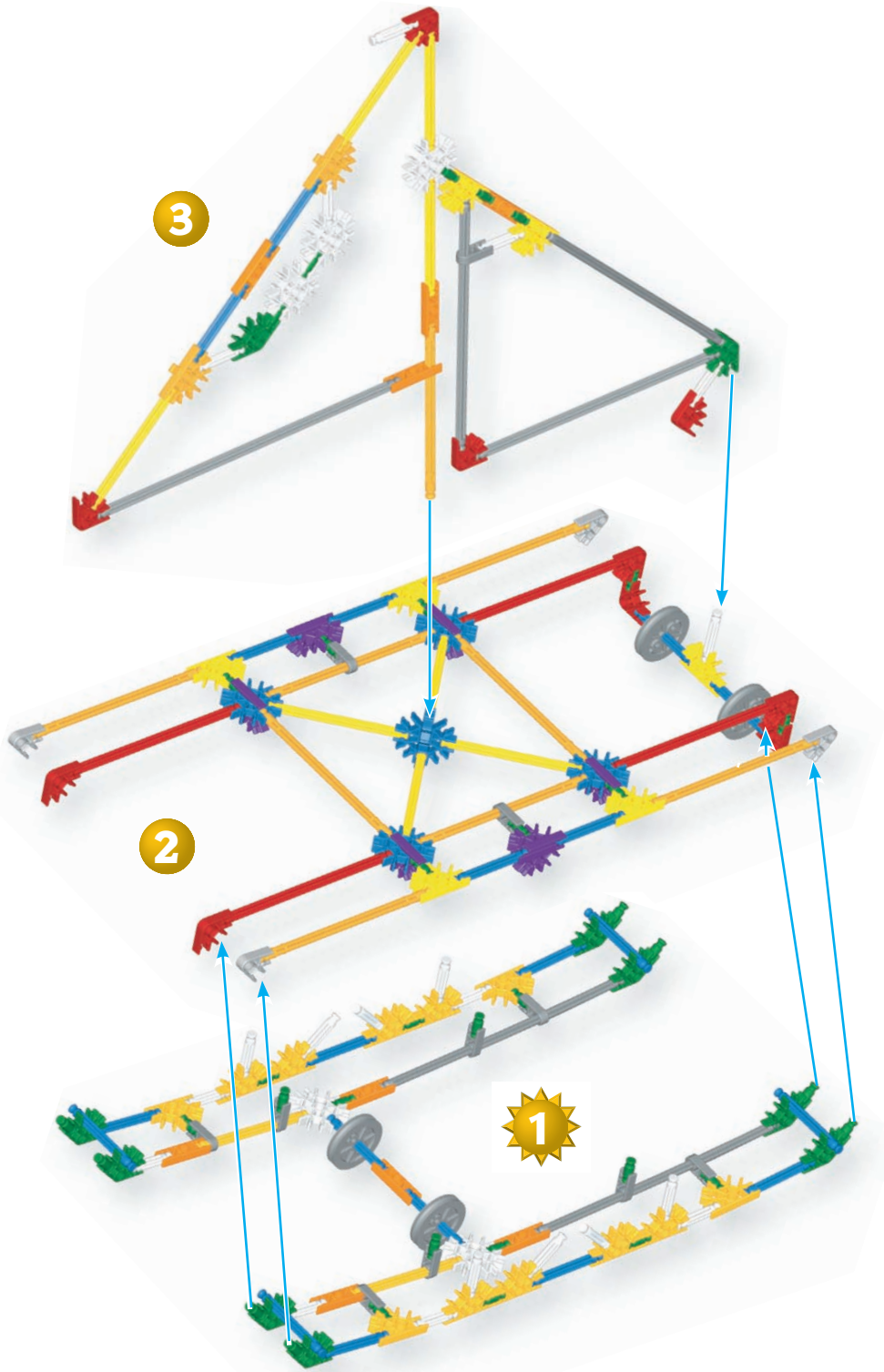

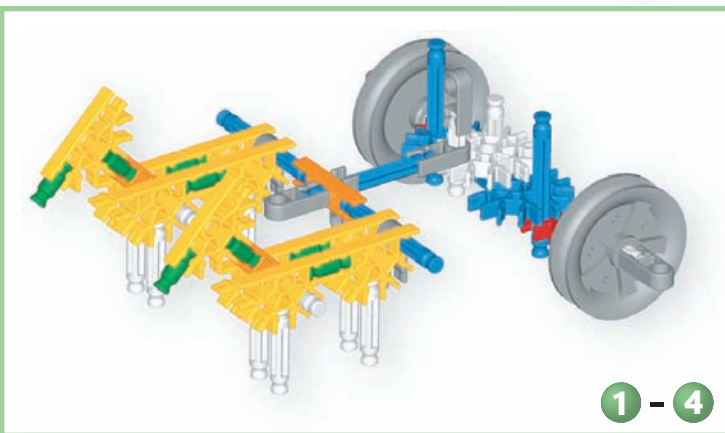
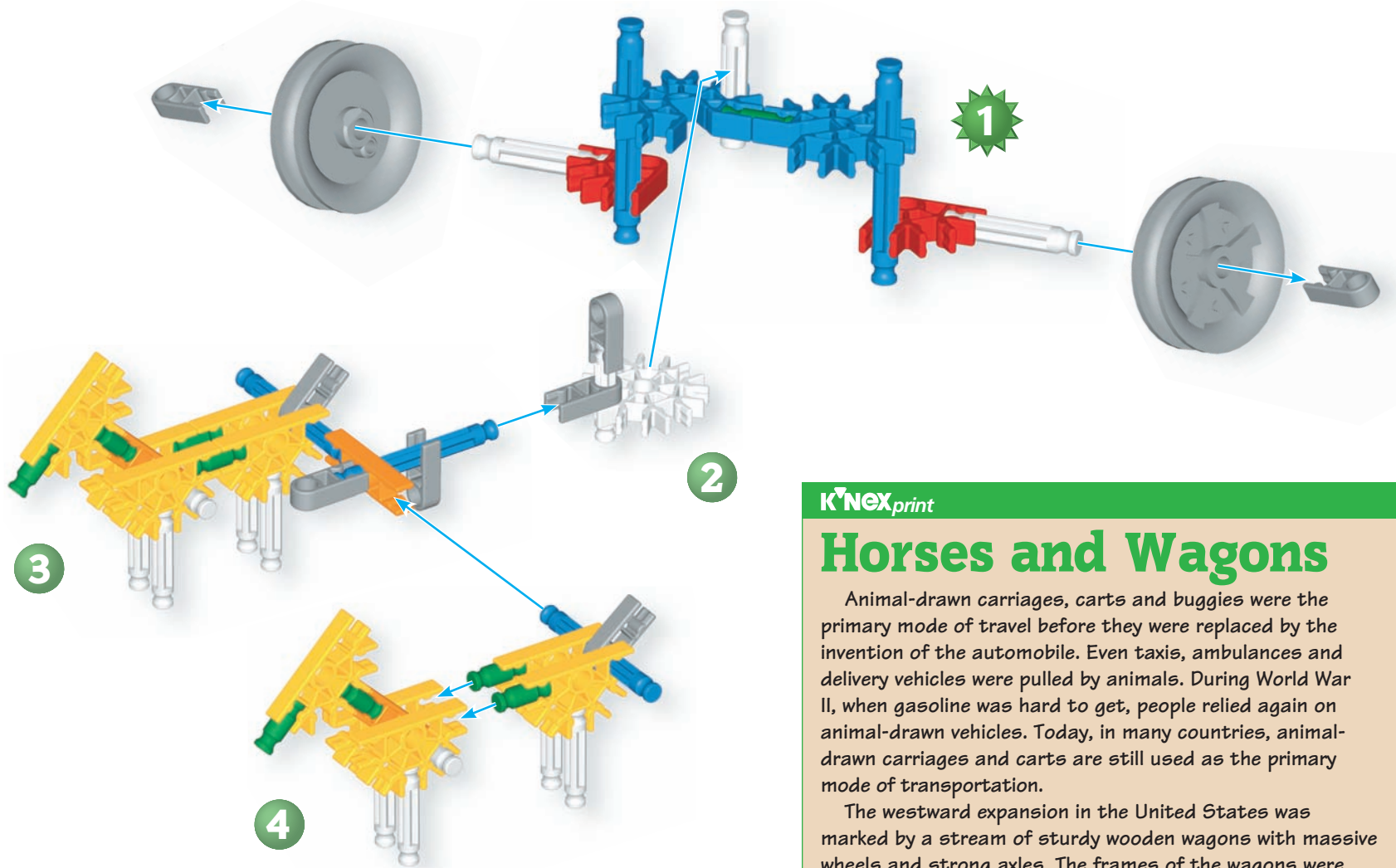

K'NEX<sub>print</sub>

## Horses and Wagons

Animal-drawn carriages, carts and buggies were the primary mode of travel before they were replaced by the invention of the automobile. Even taxis, ambulances and delivery vehicles were pulled by animals. During World War II, when gasoline was hard to get, people relied again on animal-drawn vehicles. Today, in many countries, animal-drawn carriages and carts are still used as the primary mode of transportation.

The westward expansion in the United States was marked by a stream of sturdy wooden wagons with massive wheels and strong axles. The frames of the wagons were covered with a heavy, waterproof canvas that protected the travelers from varying weather conditions. Iron tires covered the wheel rims, which made it easier to cross rough, uncharted terrain. As many as six oxen, horses or mules were attached to the wagons by wooden or metal poles and rope or leather straps. Drivers controlled these animals with the leather straps and reins.

4		16		3		22	
3		16		10		27	
2		6		2		5	
		4		4		3	
						4	

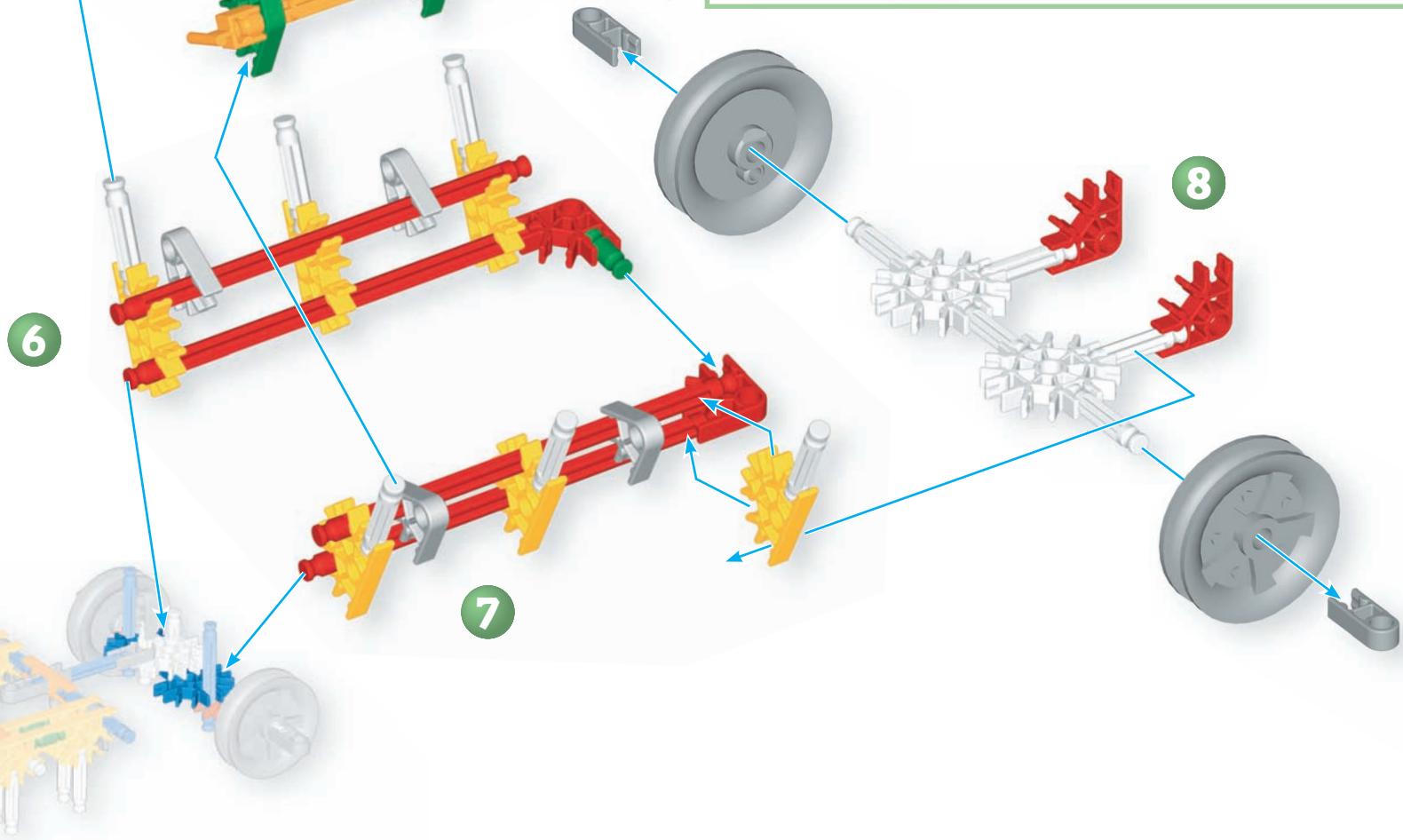

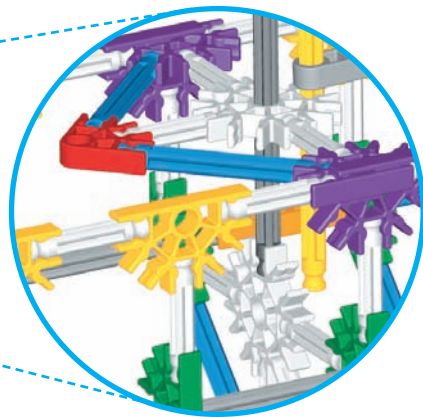
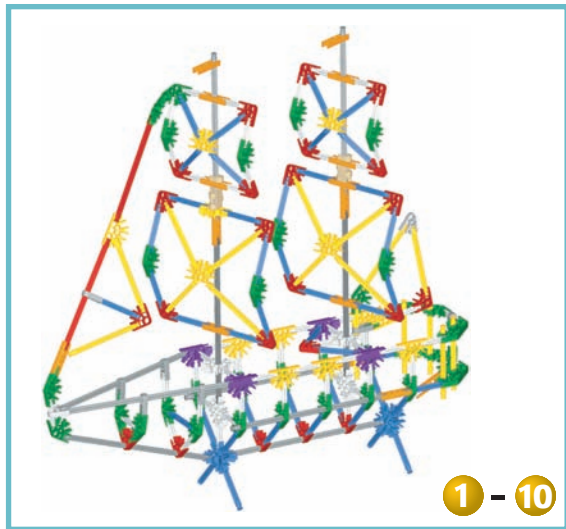
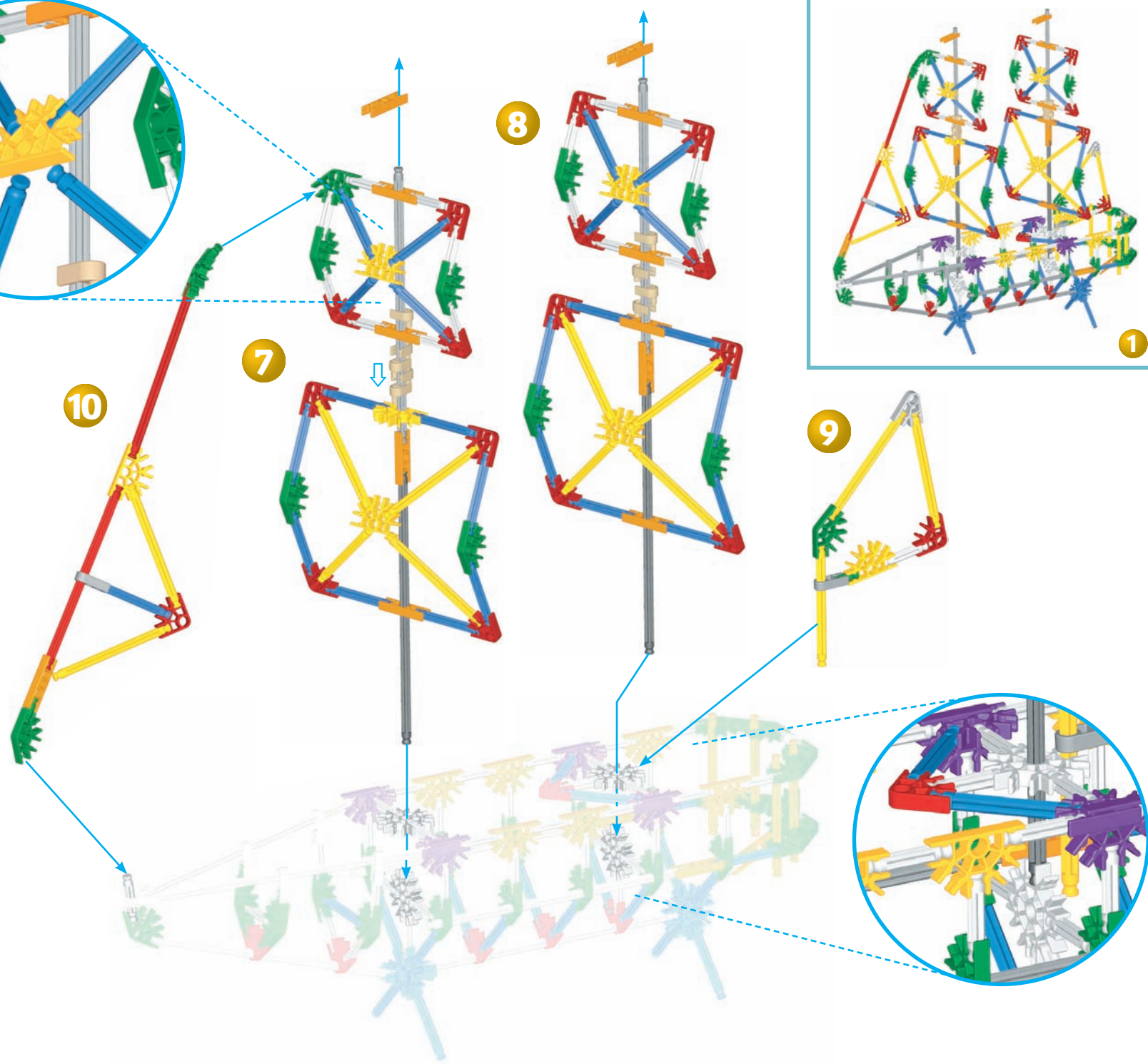
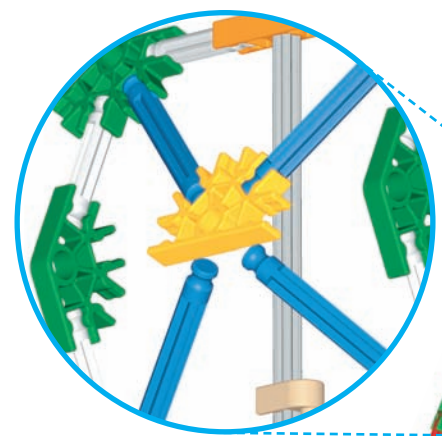
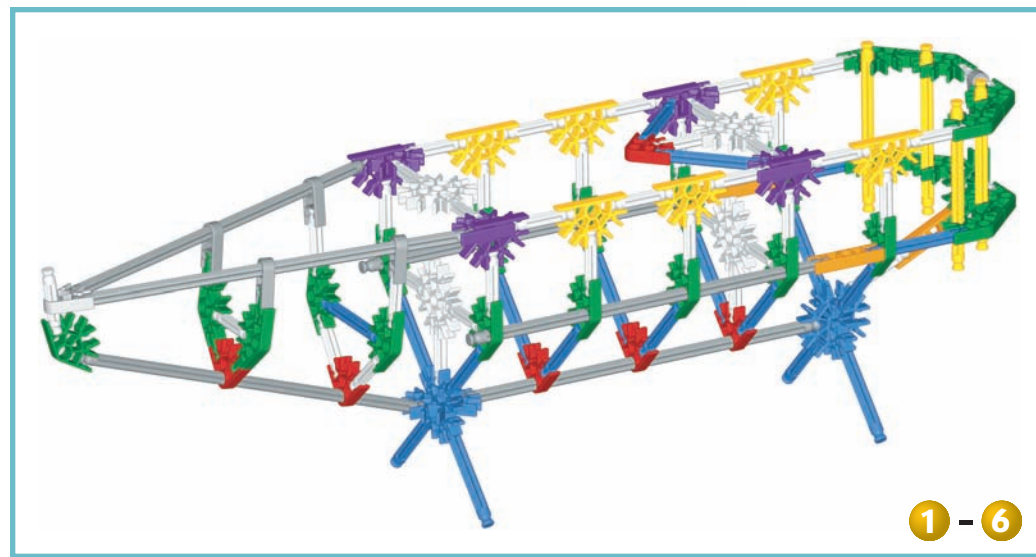
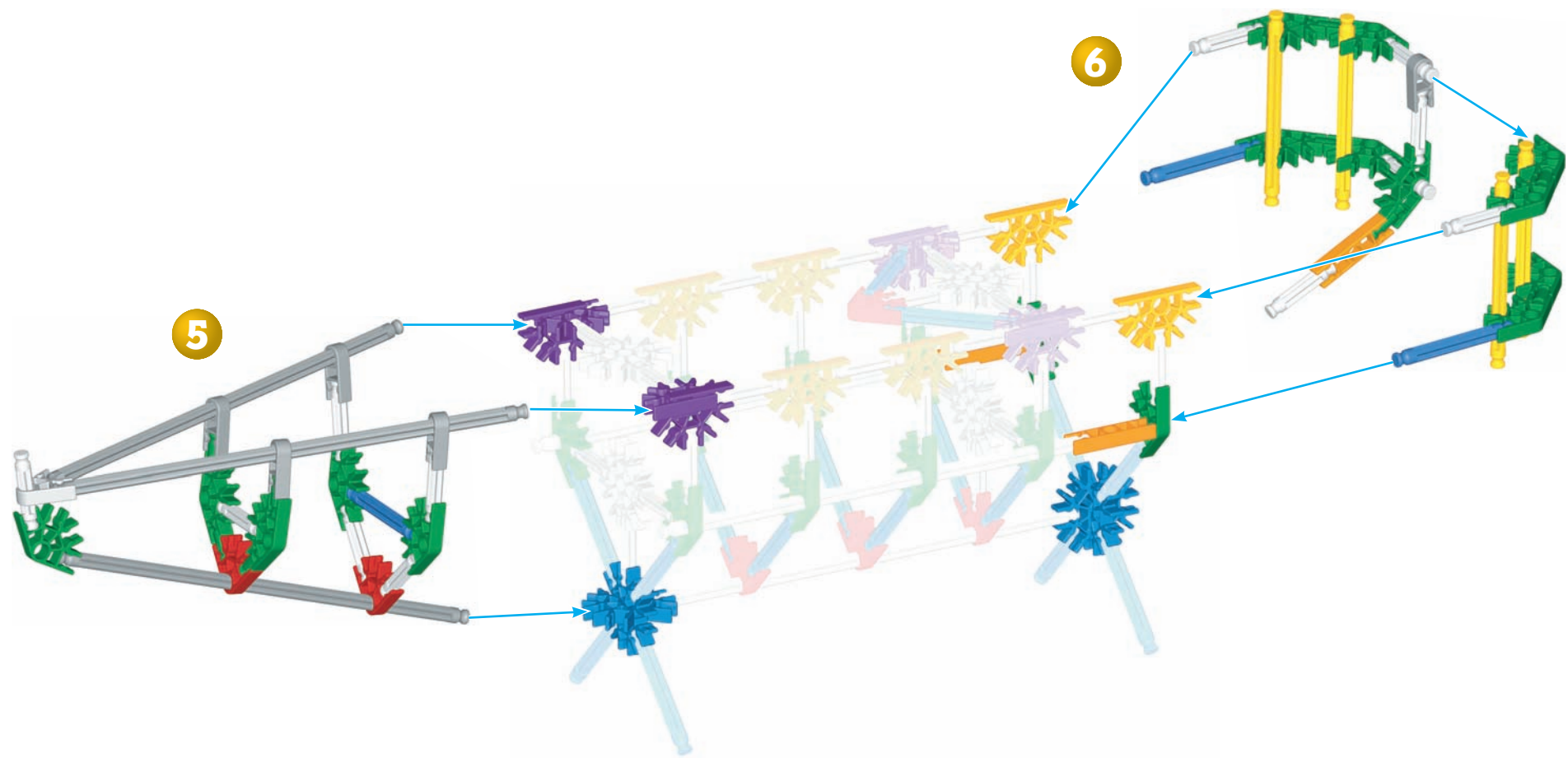

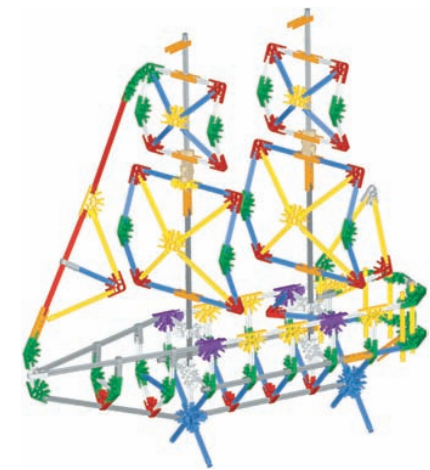
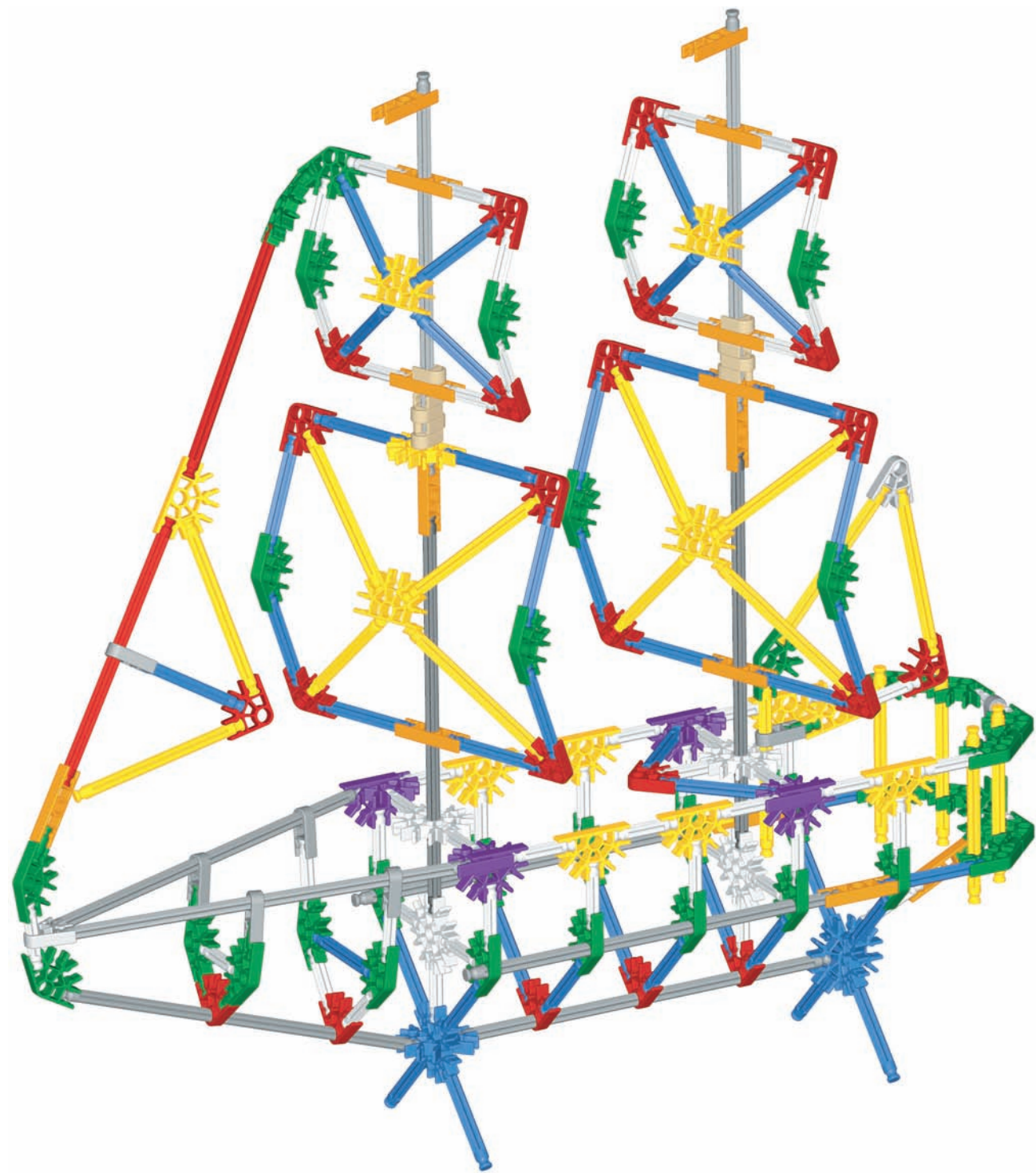

K'NEXprint

## Clipper Ships

The growth of world trade in the 19th century created a demand for larger and faster ships. American builders developed the clipper ship to meet this need. Built for speed and endurance, they were named for their ability to "clip" the miles and time off a sea-faring voyage. These trading ships sailed at record speeds for the time (as fast as 20 mph [32 km/h]). They could transport cargo across the Atlantic Ocean in only twelve days. Tea was a common cargo as clippers traveled back and forth from Chinese ports.

Typical clippers had three masts and could support as many as 35 sails. For sport, boat owners would bet on which tea clipper would complete the trading route first.

4	36	12
4	23	58
13	2	44
8	15	17
	7	2
	9	10

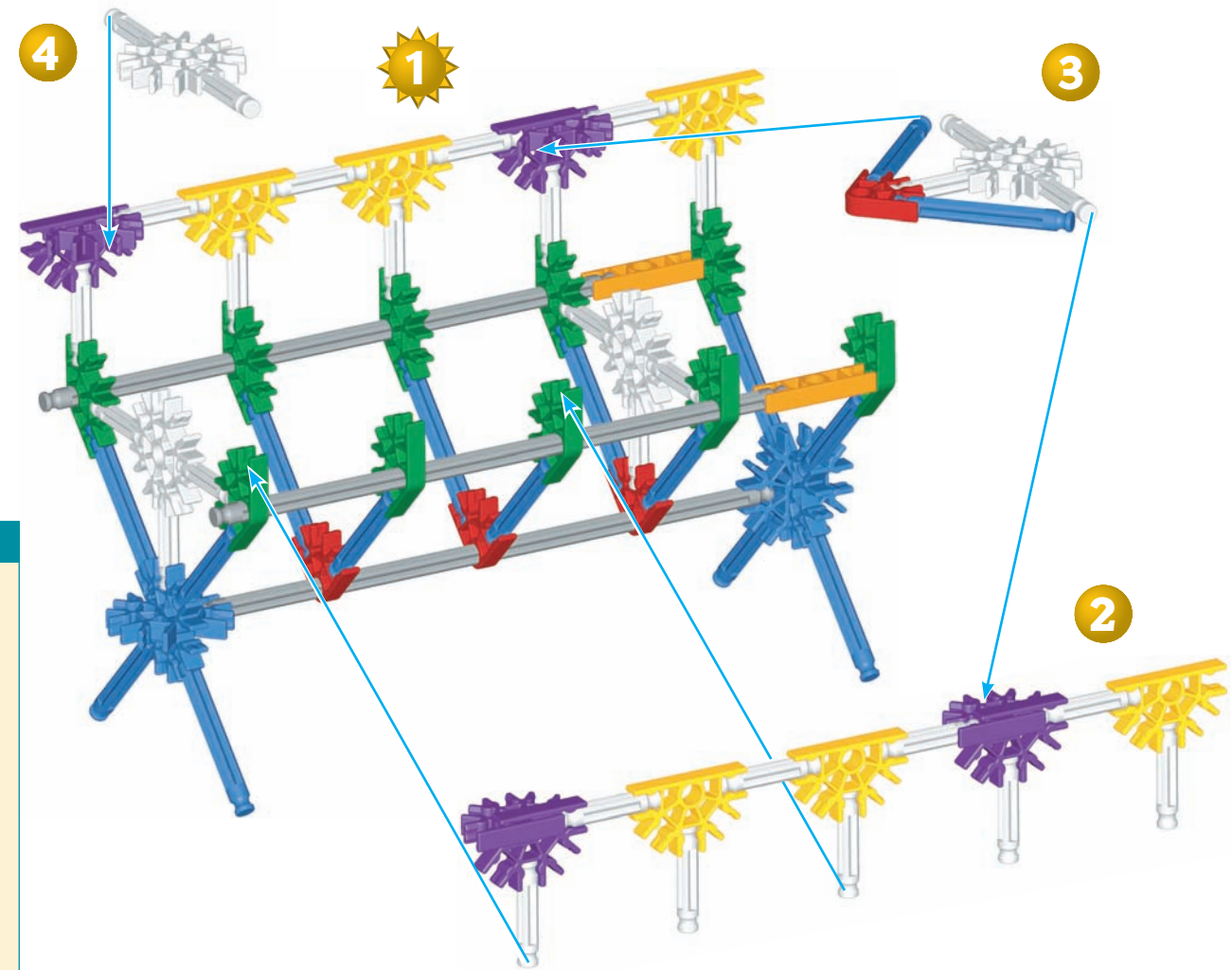

# Tricycle Sprinters

Bicycles were developed from two-wheeled machines called hobbyhorses which were common in the 19th century. The Rover Safety Bike, built in 1885, was the first modern bicycle with pedals that drove the rear wheel through a chain. It also had a diamond-shaped frame, wheels of the same size, steering and brakes.

Tricycles are bikes with three wheels set up in a triangular shape. With one wheel in front and two in back, they are naturally balanced. Today, tricycles are used primarily by young children since a sense of balance is not required to ride them. It takes more effort to pedal a tricycle than a two-wheeler since the weight of the bike and the rider is driven solely by the pedals on the front wheel. An early version of a tricycle which was very large and allowed two riders to bike side by side, was called the "sociable".

- 1 
- 2 
- 4 
- 3 
- 8 
- 4 
- 6 
- 2 
- 2 
- 7 
- 5 
- 4 

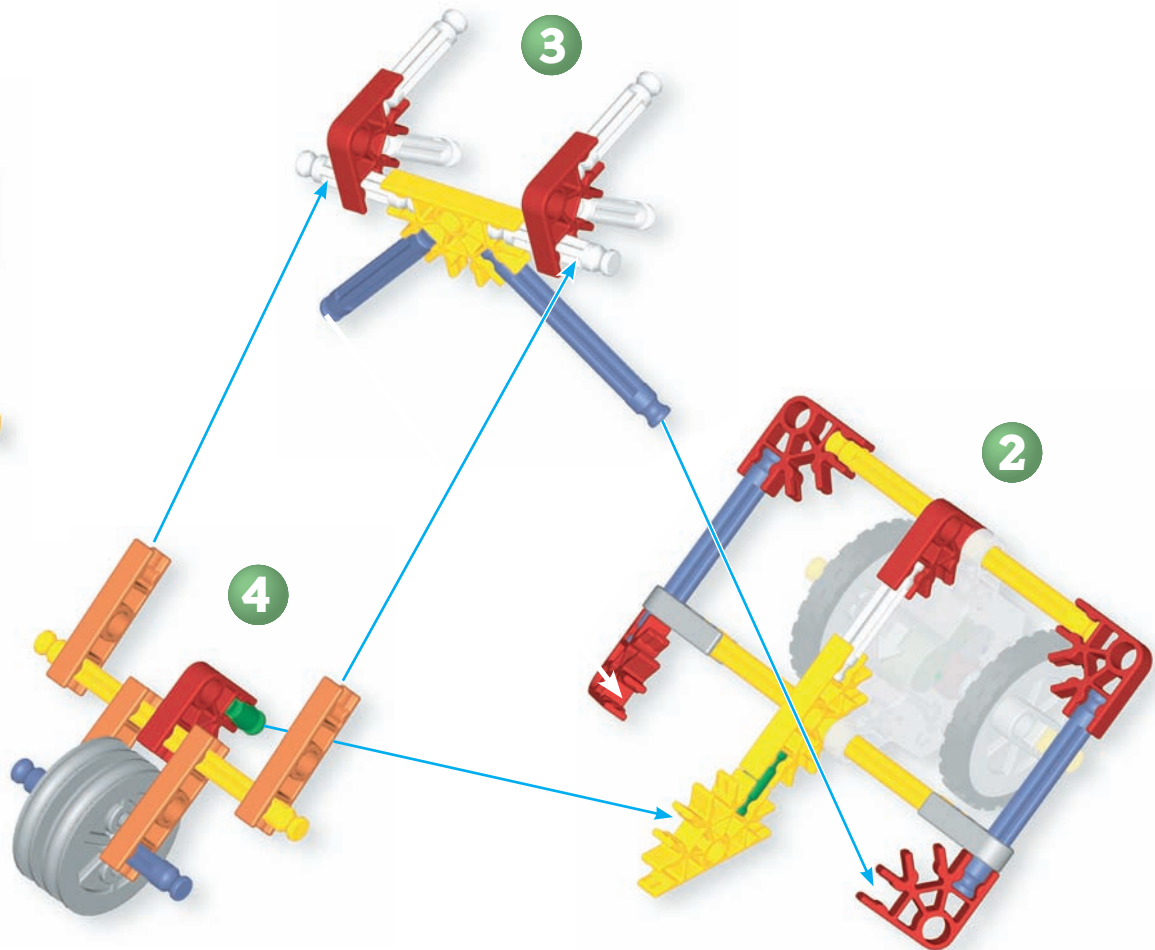
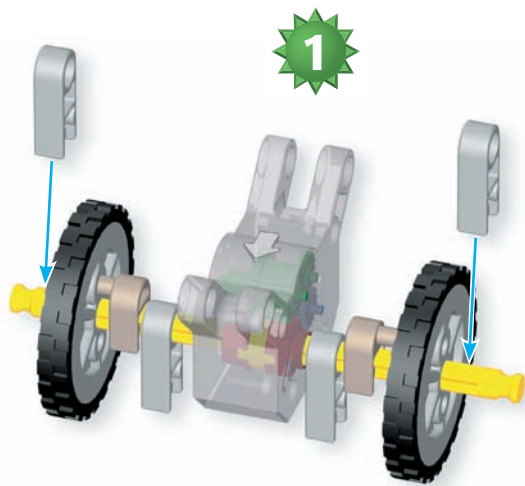
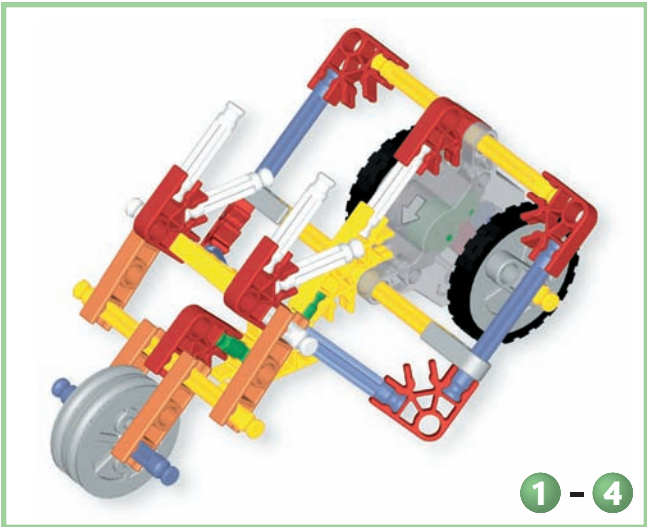



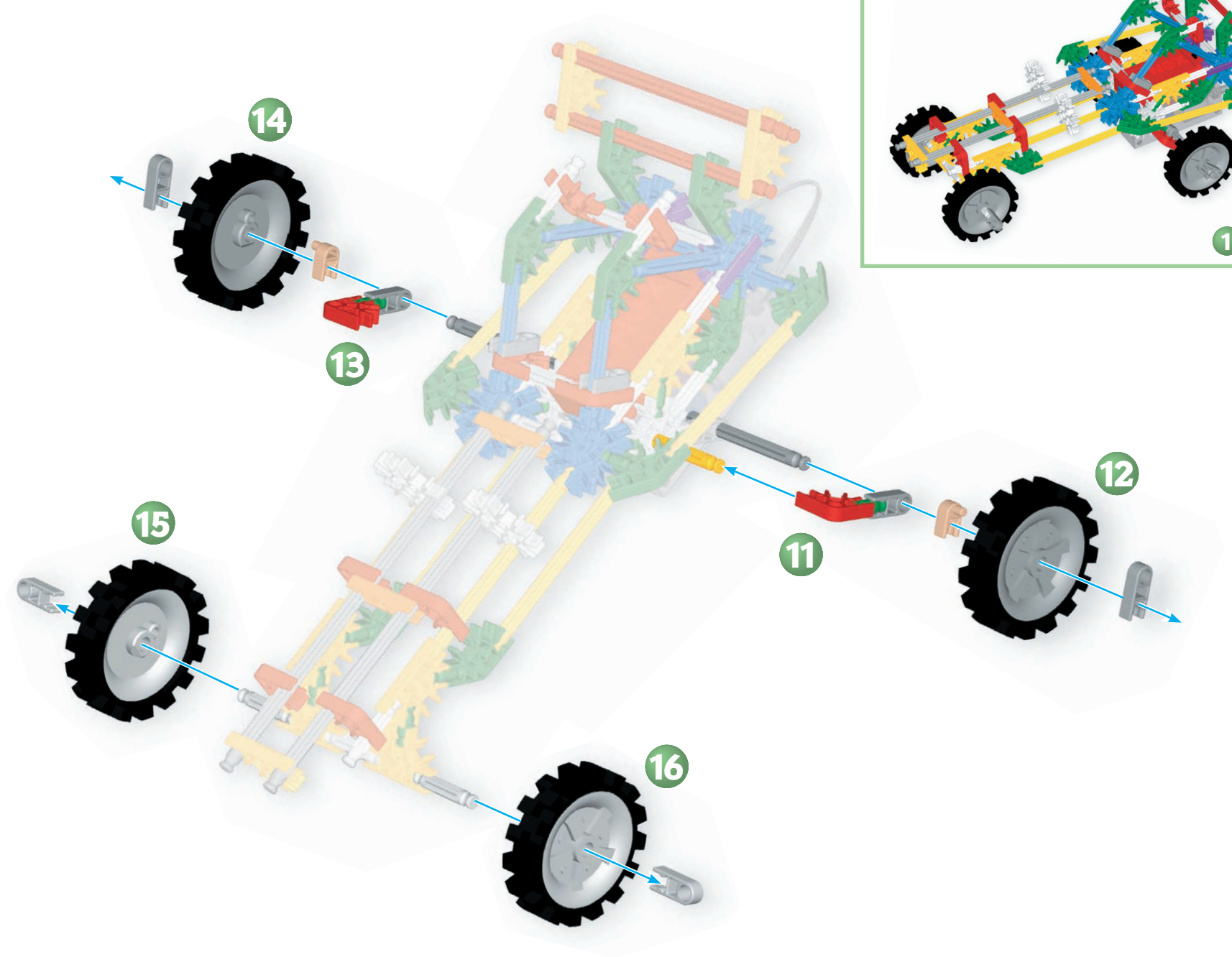
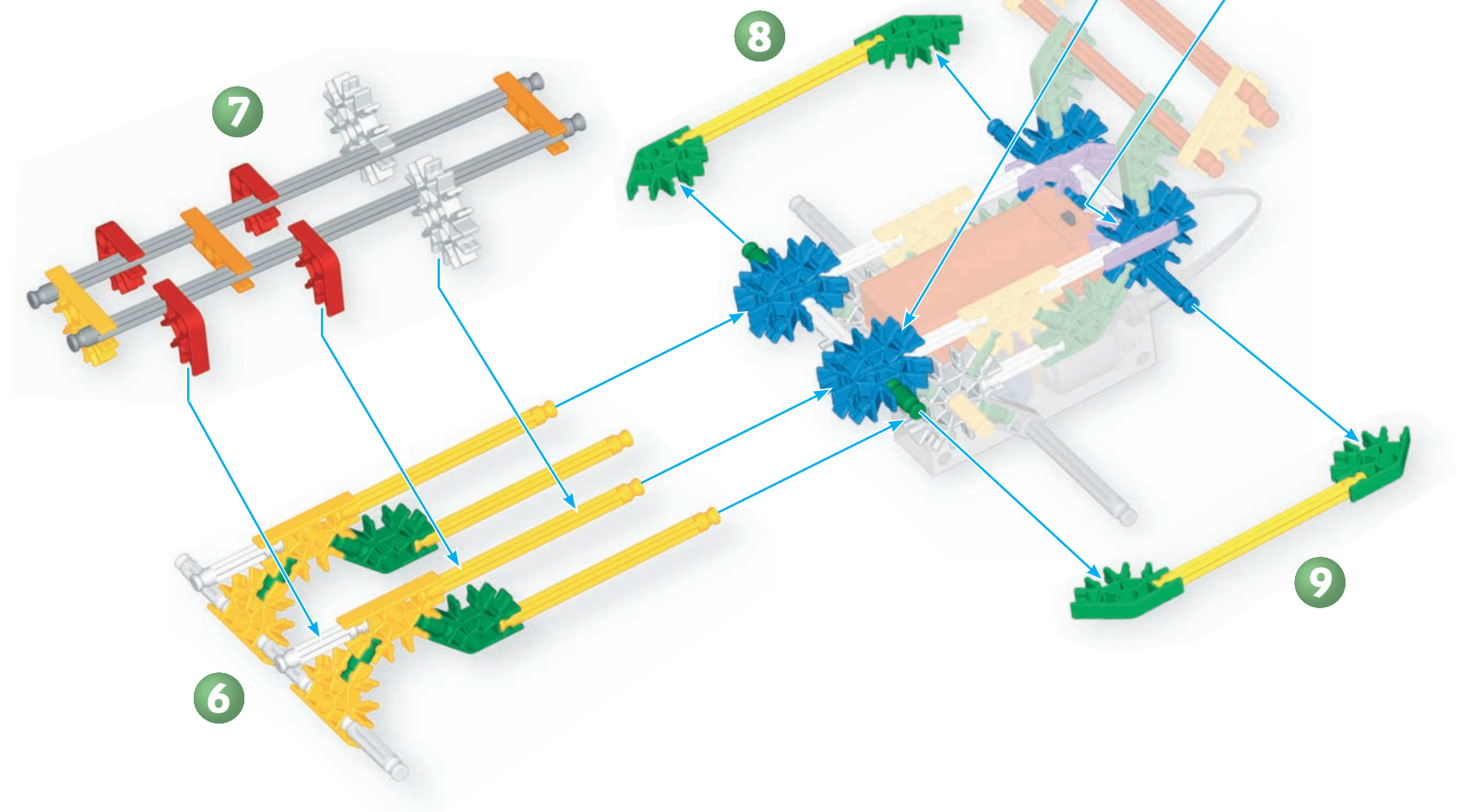
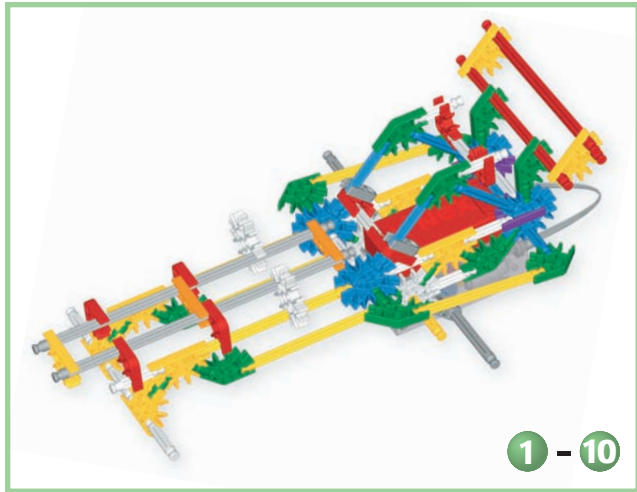

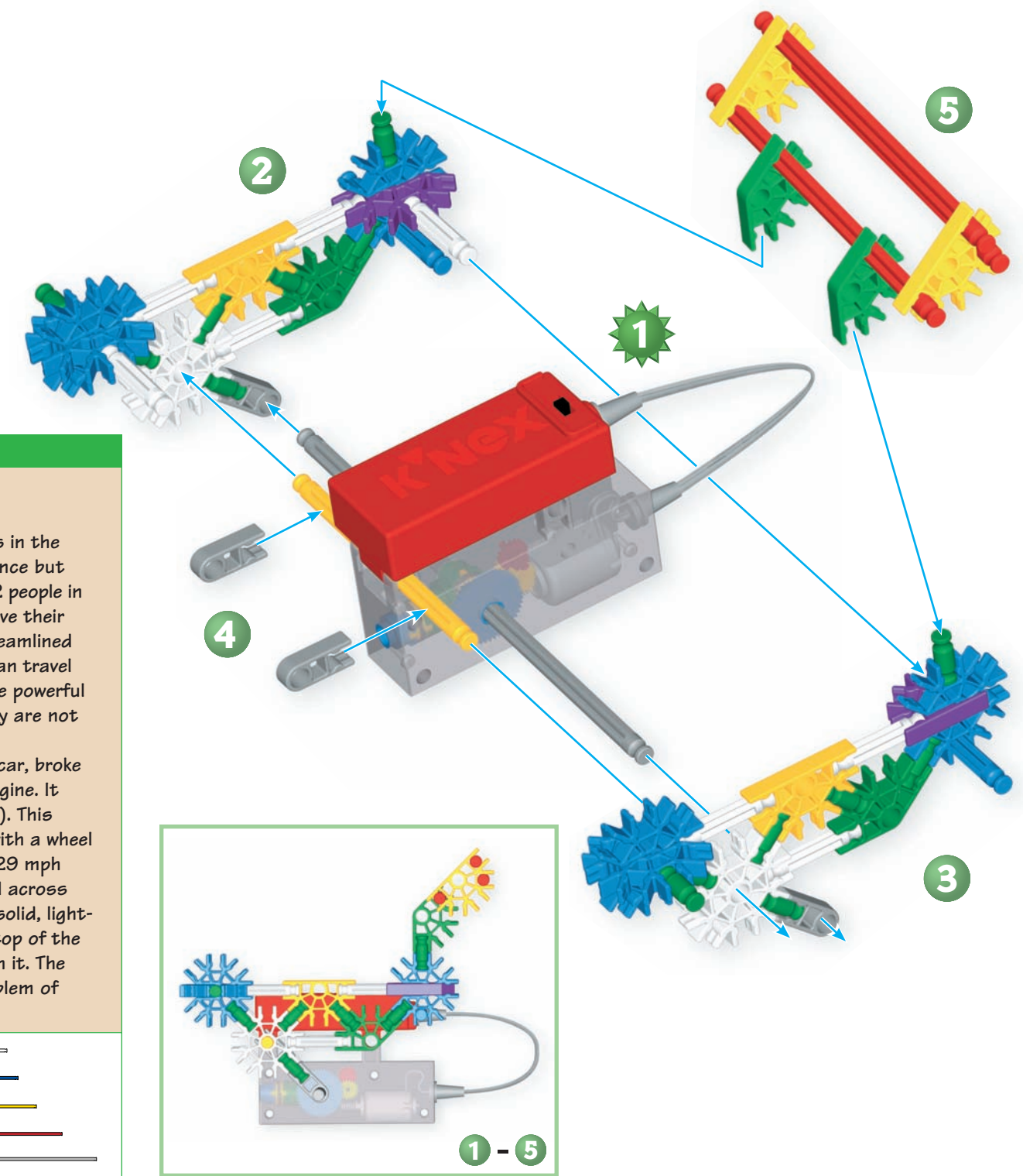

K'NEXprint

## Desert Racers

Many racing cars position their engines in the middle of the vehicle which enhances balance but cuts down on seat space allowing only 1-2 people in the car. Others, like this K'NEX version, have their engines in the back of the vehicle. The streamlined design reduces wind resistance so they can travel quickly and use fuel more efficiently. These powerful vehicles reach such high speeds that they are not legally driven on roadways.

In 1983, the Thrust 2, a British racing car, broke the world's speed record by using a jet engine. It achieved a speed of 633 mph (1020 km/h). This surpassed the maximum speed of a car with a wheel driven engine, which has a top speed of 429 mph (692 km/h). Driving tests were conducted across the desert in Reno, Nevada. Using small, solid, light-weight aluminum tires, the car glided on top of the sand's surface instead of plowing through it. The solid tire design also eliminated the problem of punctures and blowouts.

1		4		10		17	
4		6		2		6	
		9		12		7	
4		2		2		3	
		12		20		3	

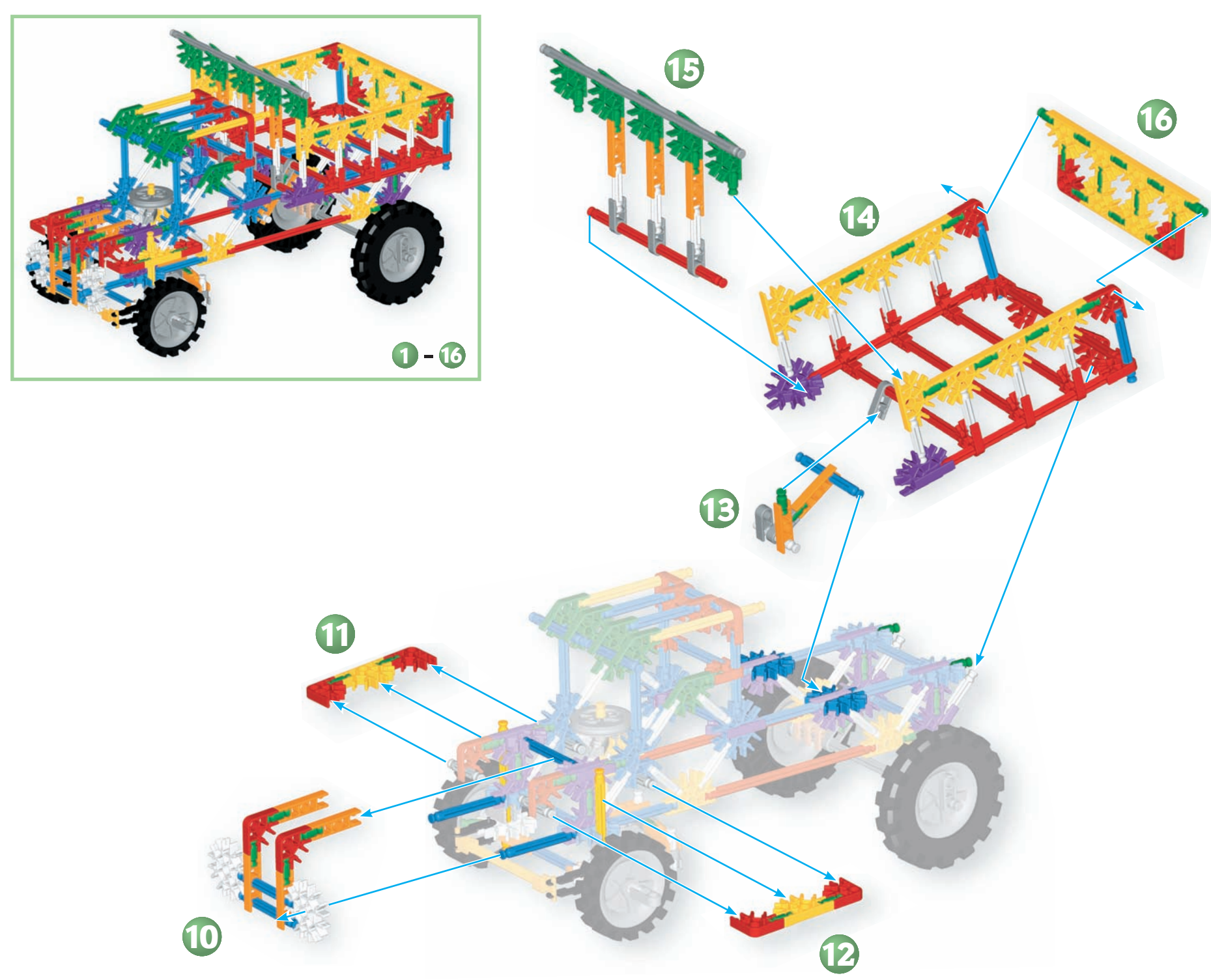
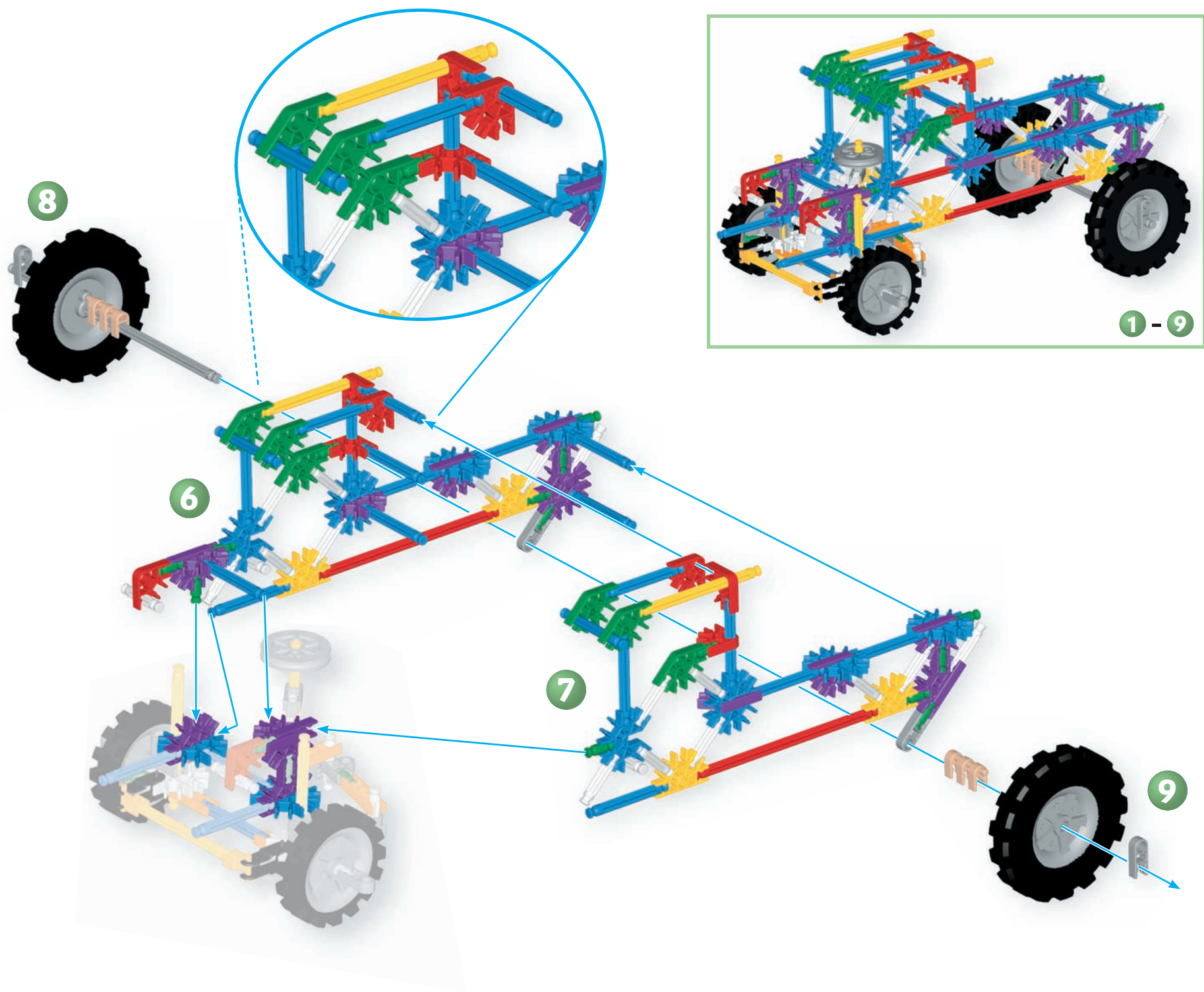

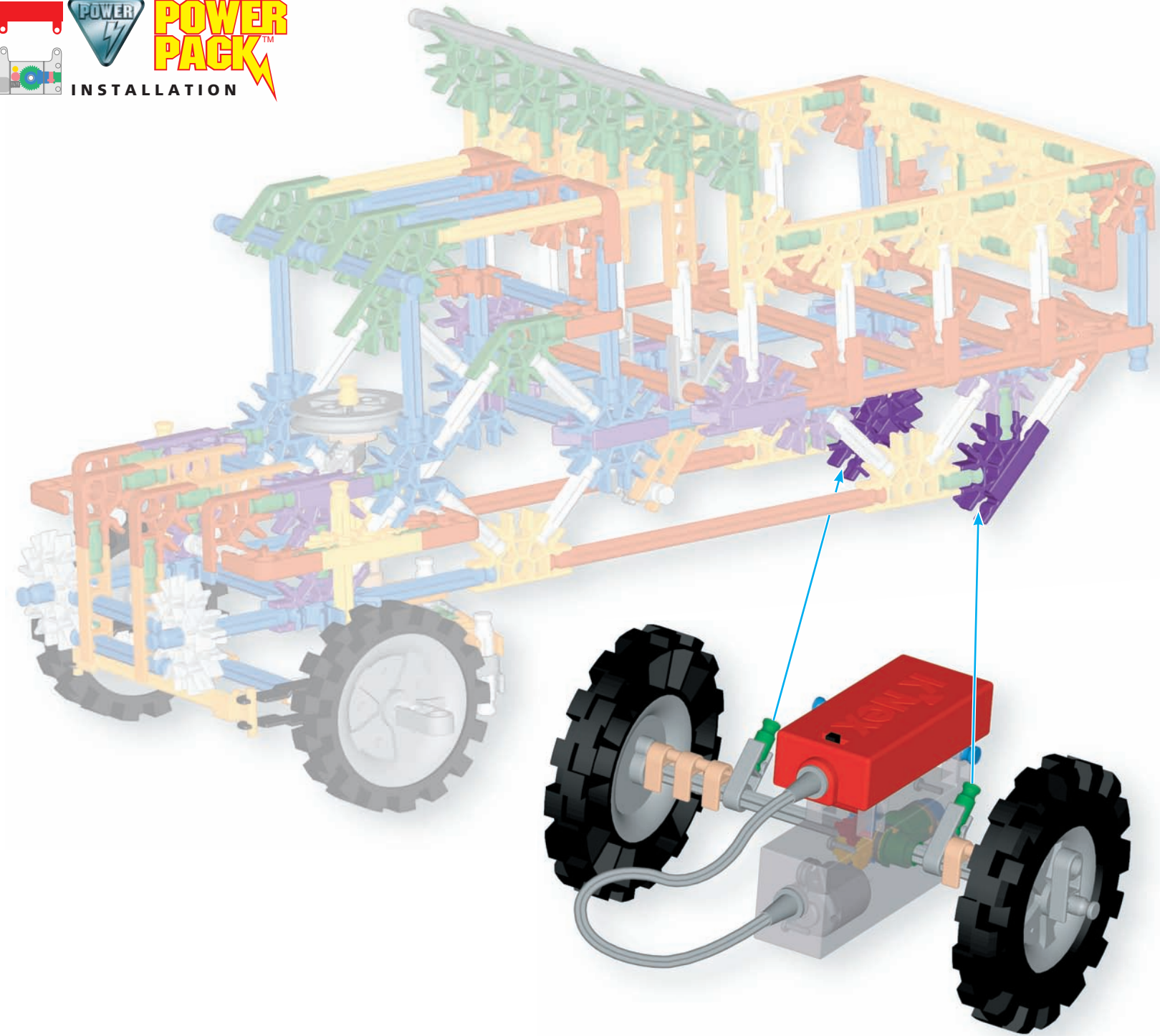
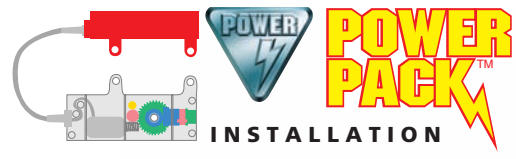

K'NEXprint

## Dump Trucks

Dump trucks were developed because it took a long time to shovel loose materials like coal and gravel out of a traditional truck. The early model dump trucks had removable sides and hinged tailgates. These trucks were loaded shovel by shovel. To unload, the truck body was cranked up on an incline, and the tailgate was opened to release the load. Today, powerful machines (hydraulic rams) use fluid to push up the truck bed rather than cranking manually. Dump trucks which transport delicate loads, like grain, lift the bed gently and the load flows slowly through a small valve.

2	4	20	13	56	1
1	1	20	24	39	(optional)
2	4	11	8	29	6
	10	28	2	9	2
			2	2	

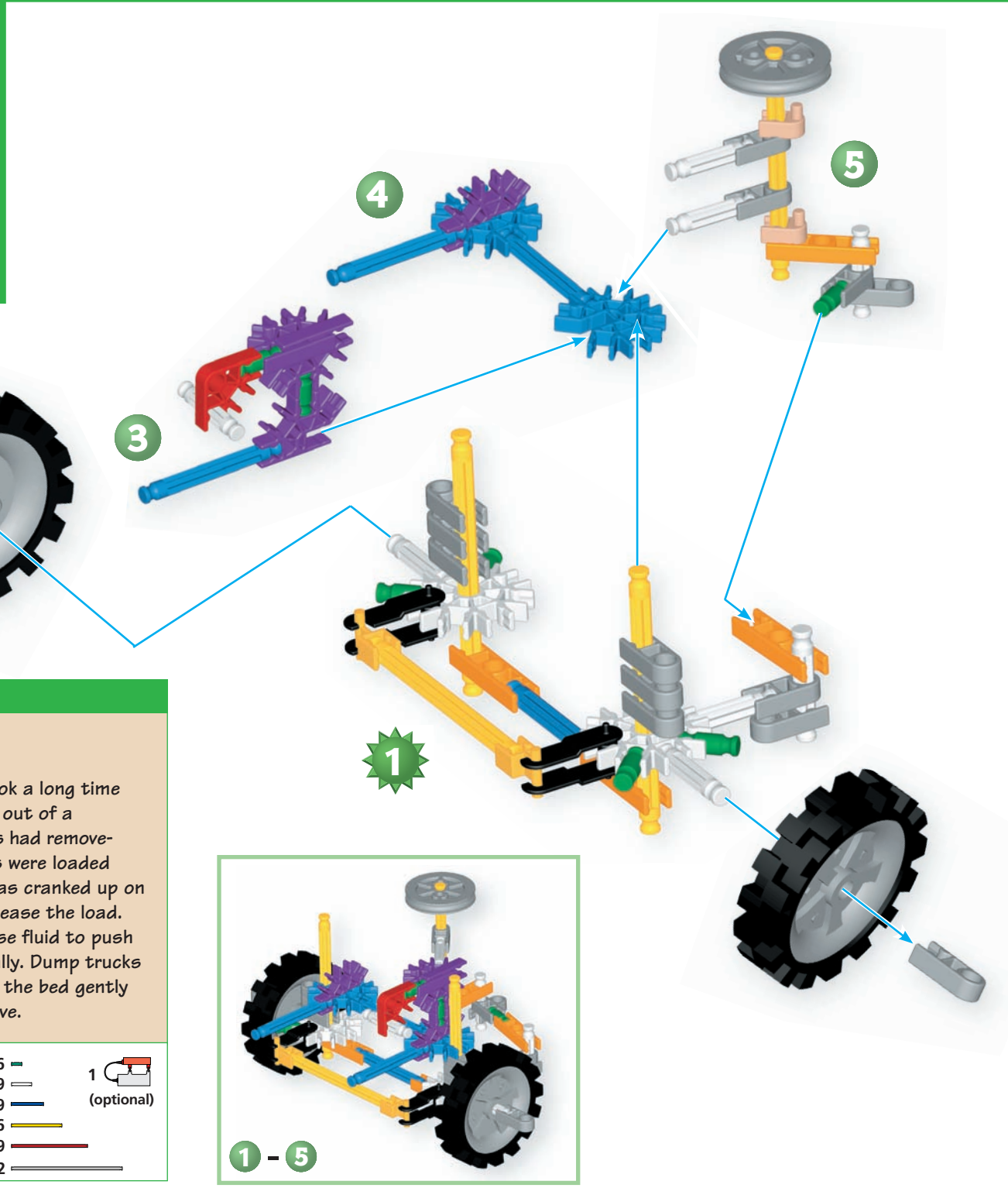

# Starships

The bright stars in the sky have always been the subject of human curiosity. The nearest star to Earth, Proxima Centauri, lies at least 25 trillion (25,000,000,000,000) miles (40,225,000,000,000 km) away. Human travel to the stars depends on our ability to build a spacecraft that can cover trillions of miles in less than a human lifetime *and* carry enough materials to keep someone alive during the trip.

The distances between stars can only be measured in light-years. One light-year is the speed that light travels in one year (six trillion miles). Scientists already have ideas about how to make superfast spaceships — some traveling the speed of light or even faster. One example, a starship named Daedalus, designed by the British Interplanetary Society, could be launched this century. Its goal is to reach a star in 50 years or less. Its design team chose nuclear fusion as the method for powering the Daedalus. Scientists continue to work on what once seemed an impossible task and will likely make it happen!

1		2		1		16		2		18	
								1		34	
		2		8		6		7		1	



1 - 3

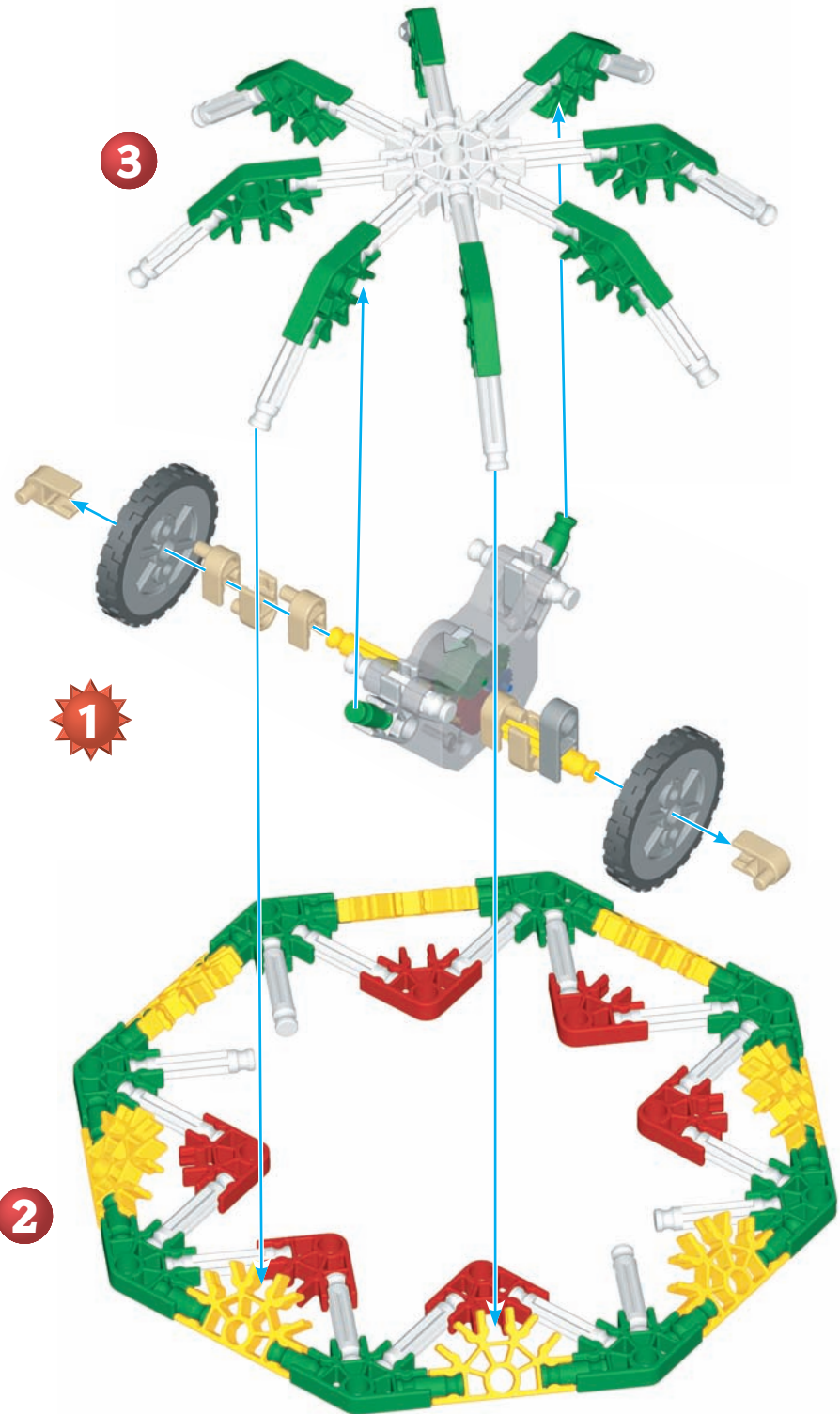

## UFO's

An "unidentified flying object" (UFO) is a strange object seen flying in the sky that is not easily recognized or understood. Usually, someone with specialized knowledge can provide an explanation—for instance, they might be airplanes, missiles, balloons or spacecraft that conduct scientific or secret experiments. Even though scientists and government officials can explain most occurrences, reports still come in about objects which baffle the experts.

The excitement surrounding UFO's and flying saucers started in 1947 when a pilot saw an arrangement of bright circular objects, which looked like "saucers flying through the air," in the sky near Mount Rainier, Washington. The name "flying saucers" was coined and is often used to describe UFO's.



# Hang Gliders

Hang gliding is not actually flying; it is managing a controlled fall while soaring like a kite. Glider pilots fly silently like some birds and use their body weight and position to steer. Hang gliders are narrow and lightweight with extra long wings that create lift as wind passes over and underneath. Descent is accomplished through the pilot's body positioning, the wing angle, use of air currents and luck related to wind and weather conditions.

Hang gliders don't have engines; they rely on thermals – different temperatures of air at different levels in the sky – for successful lift and glide. To take off, pilots either run off the side of a mountain or are towed off the ground by a plane or car.

1  5  1  1  4  2  11  6 



# Helicopters

Although designed by Italian artist and inventor, Leonardo da Vinci, in the late 1400's, it was not until 1907 that a helicopter could successfully lift its own weight (even if only for 20 seconds). The addition of new lightweight materials led Russian designer, Igor Sikorsky, to build a helicopter that flew with a rotor configuration (rotating horizontal blades) that remains the basis of helicopter design today.

Unlike fixed winged aircraft, which require forward motion to create lift, rotors create lift as they spin and cut through the air. This means a helicopter can take off vertically and hover. Helicopter rotors today have two to five blades, helping copters reach cruising speeds as high as 172 mph (277 km/h).

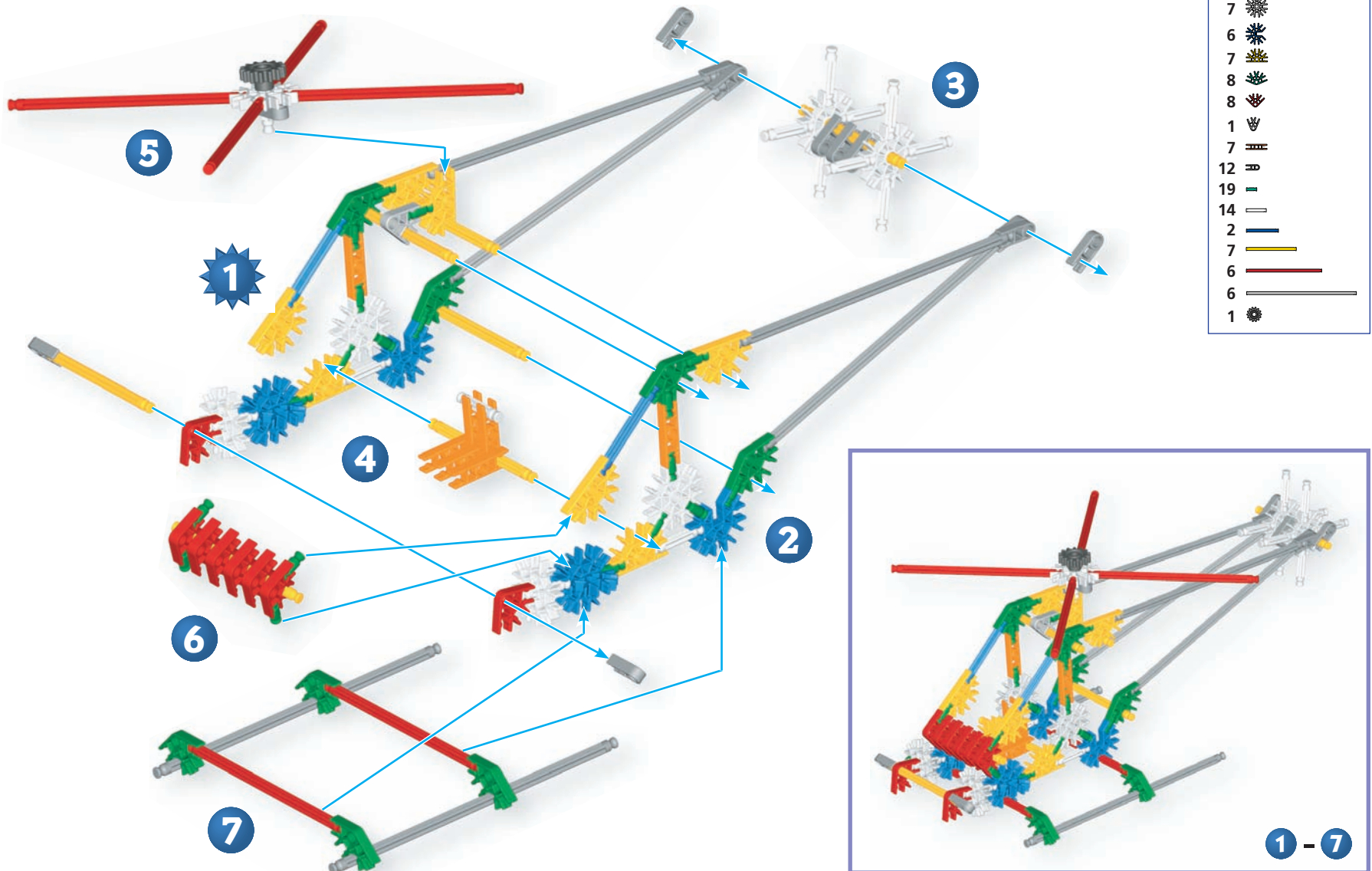

K'NEXprint

## Heliport on Oil/Gas Rigs

Natural oil and gas are often found under the sea or ocean floor. If the water is very deep, mining is done from a huge ship that drills through an opening in the ship's hull. Otherwise, a rig is set up out at sea to mine and drill for these fuels. Those working on the rig are usually stationed there for a long time. For this reason, a rig has living and working quarters, docks for large tankers transporting people and materials, and heliports.

Helicopters provide the quickest and most efficient means of transport in these circumstances. Able to land and take off in small areas, helicopters use these heliports to come and go easily with passengers, cargo and supplies between the rig and the mainland.

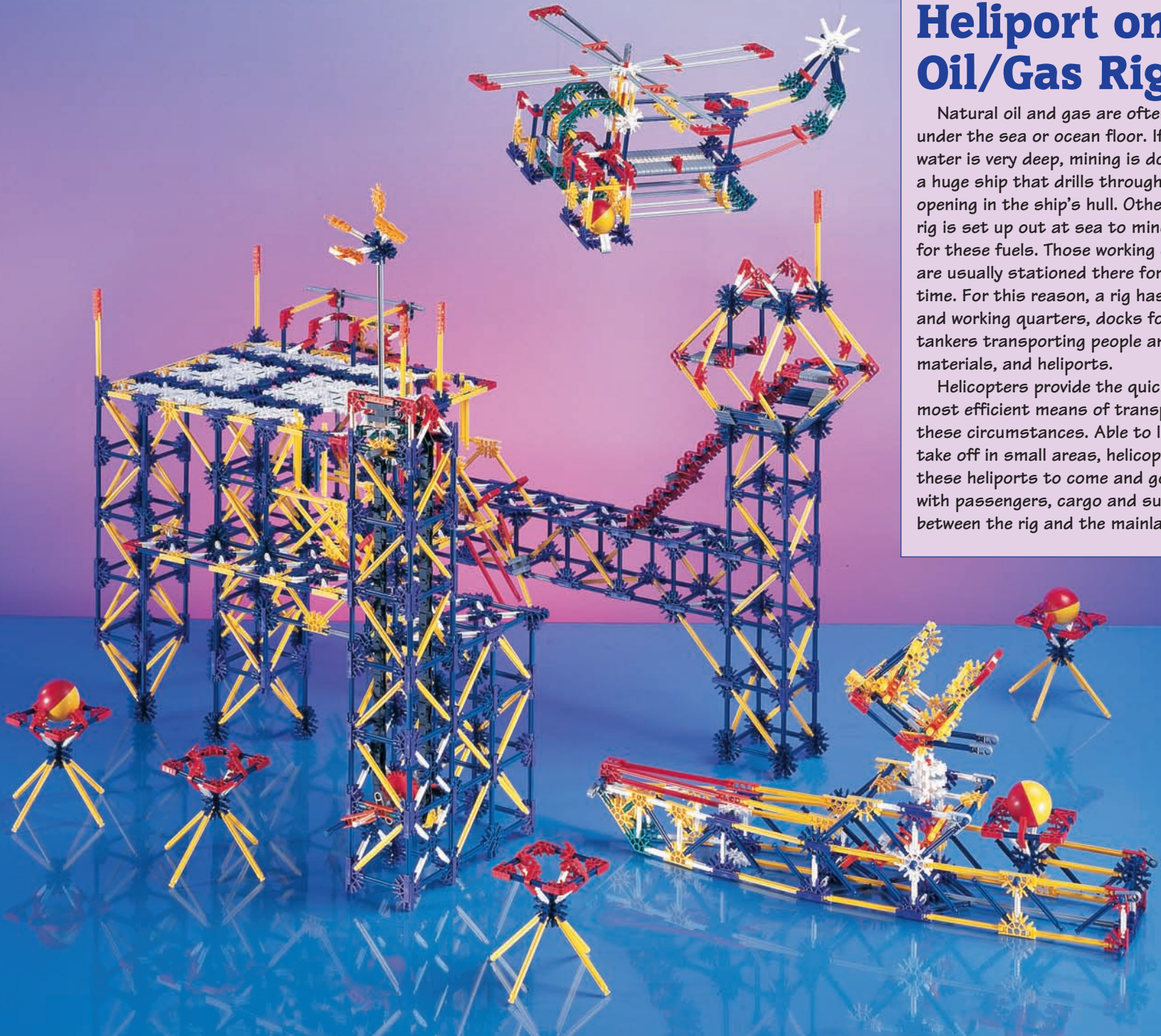









# Hot Air Balloons

Balloons have been used for travel, recreation, photography and by the military to spy and drop bombs. The strong, flexible, lightweight wicker gondola (basket) underneath the balloon envelope carries the passengers and the burner that heats the air inside the balloon, causing the balloon to soar.

Balloon height is controlled by the temperature of the air within the envelope. Hot air makes the balloon rise (ascend). Replacing the heated air with cool air causes the balloon to fall (descend). Balloon pilots, called aeronauts, cannot steer a balloon, but some control is achieved by riding the air currents. These air currents, called thermals, are pockets of air which are different temperatures and move in different directions.

Early balloon envelopes were filled with either hot air or hydrogen gas. Since hydrogen is flammable and presented serious safety issues, helium replaced it; hot air continues to be used today.

2		13		3		3		2	
2		3		14		6			

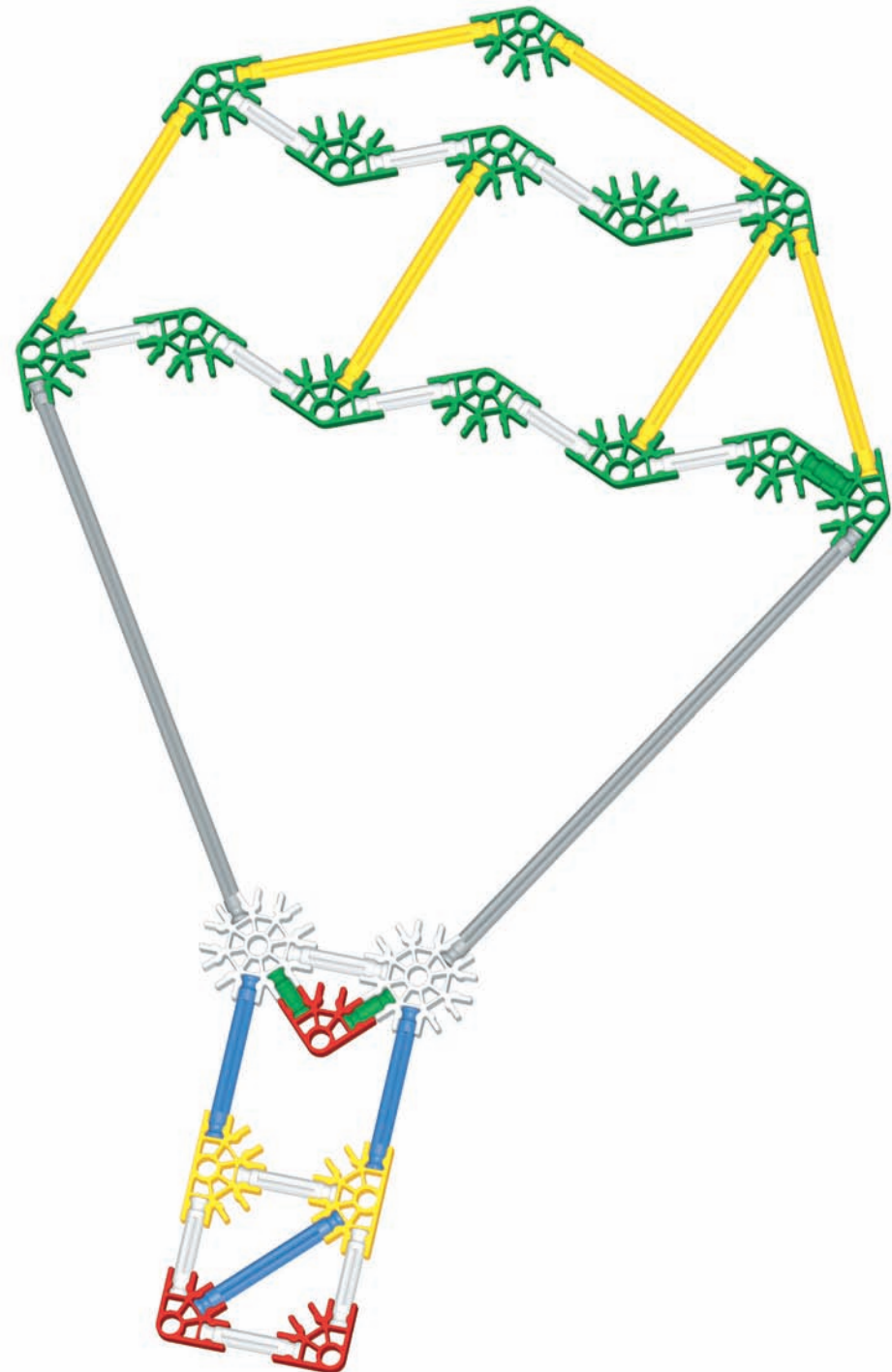

# Airboats & Hydrofoils

An airboat is a flat-bottomed boat which sits close to the surface of the water. It utilizes a propeller at the rear of the boat to drive the boat forward. Because it sits so close to the water surface, the airboat is used in swamps and marshes like the Florida Everglades. Over time, the airboat design was adapted for use with other seafaring vessels.

A hydrofoil is a boat which uses water wings and underwater foils. When stationary, a hydrofoil floats just like any boat. However, as it moves faster and faster, pressure created under the foils lifts the boat up. It travels with most of its hull out of the water nearly all of the time. The hydrofoil works like a plane—the less drag created, the higher it is lifted and the more efficiently it travels. These craft can travel up to 62 mph (71 knots). The hydrofoil is the fastest of all marine vehicles.



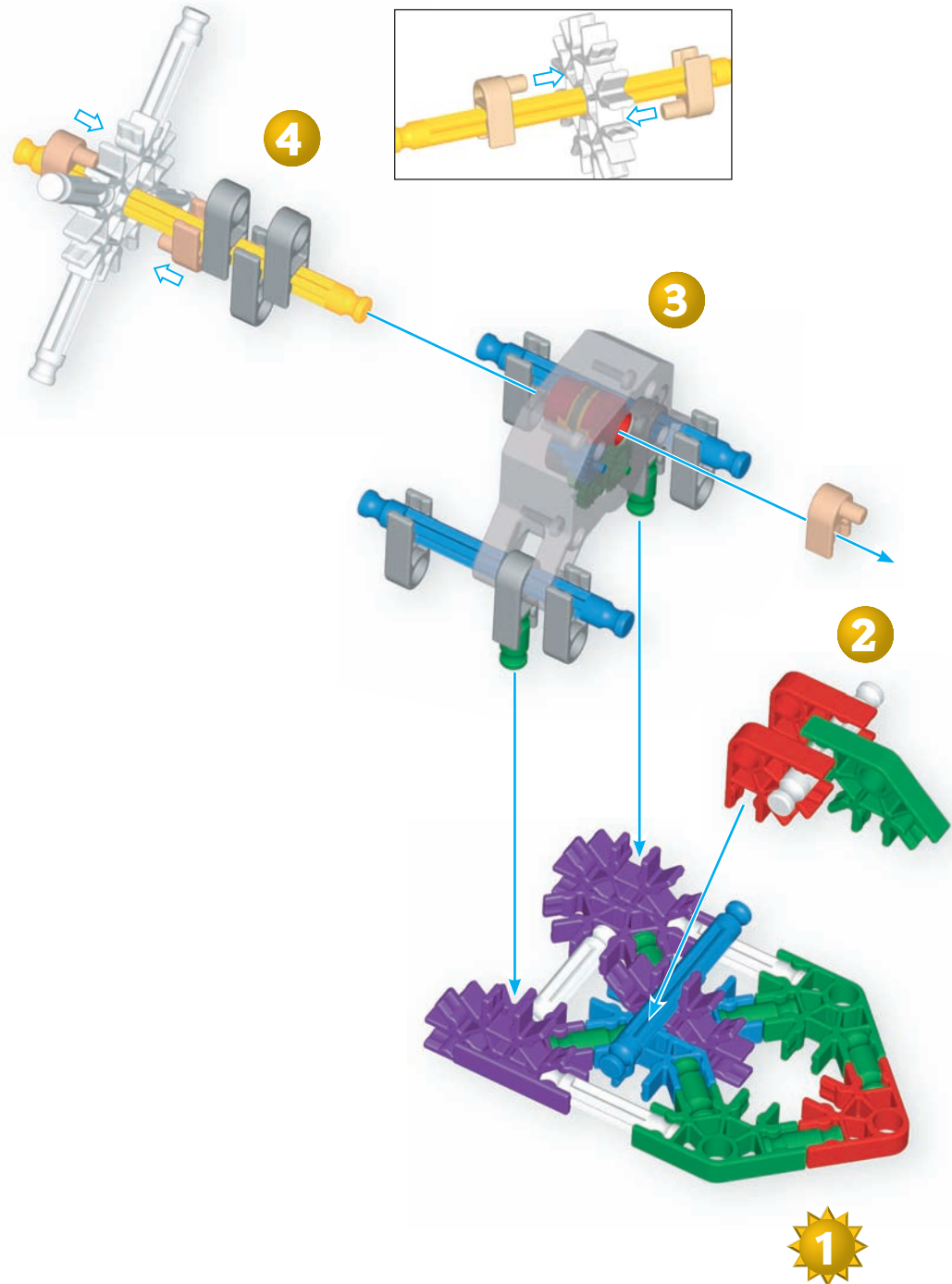
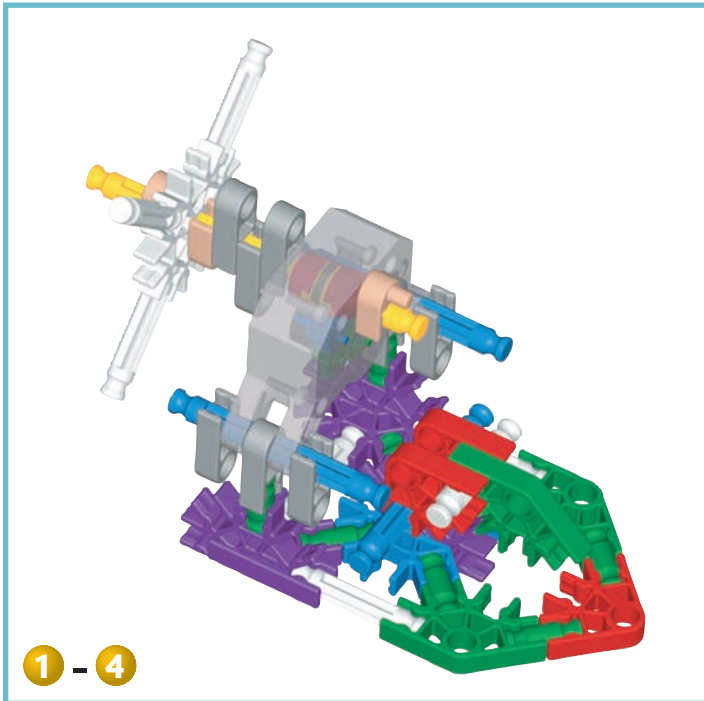









1	1	3	9	8	3
1	5	3	3	8	1



# Jet Airplanes

Invented in 1930, the jet engine creates a powerful alternative to propellers, allowing planes to be larger, go faster, and in the process, causing air travel to be more affordable. While first used in military aircraft, jet engines are used today on most medium to large sized planes.

Jet engines attach to airplane wings and work by sucking in air, mixing it with fuel, compressing the mixture and blasting it out behind, which thrusts the aircraft forward. Large jets use turbofan or turbojet engines which use a large fan to suck in even more air to mix with the fuel. The arrival of the jet engine in the 1950's caused jet airline speeds to reach almost 600 mph (967 km/h); and in the late 60's, the invention of the supersonic jet enabled these planes to break the sound barrier traveling at speeds of 1350 mph (2177 km/h)!

4 	1 	11 	1 
7 	6 	11 	2 
7 	3 	6 	4 

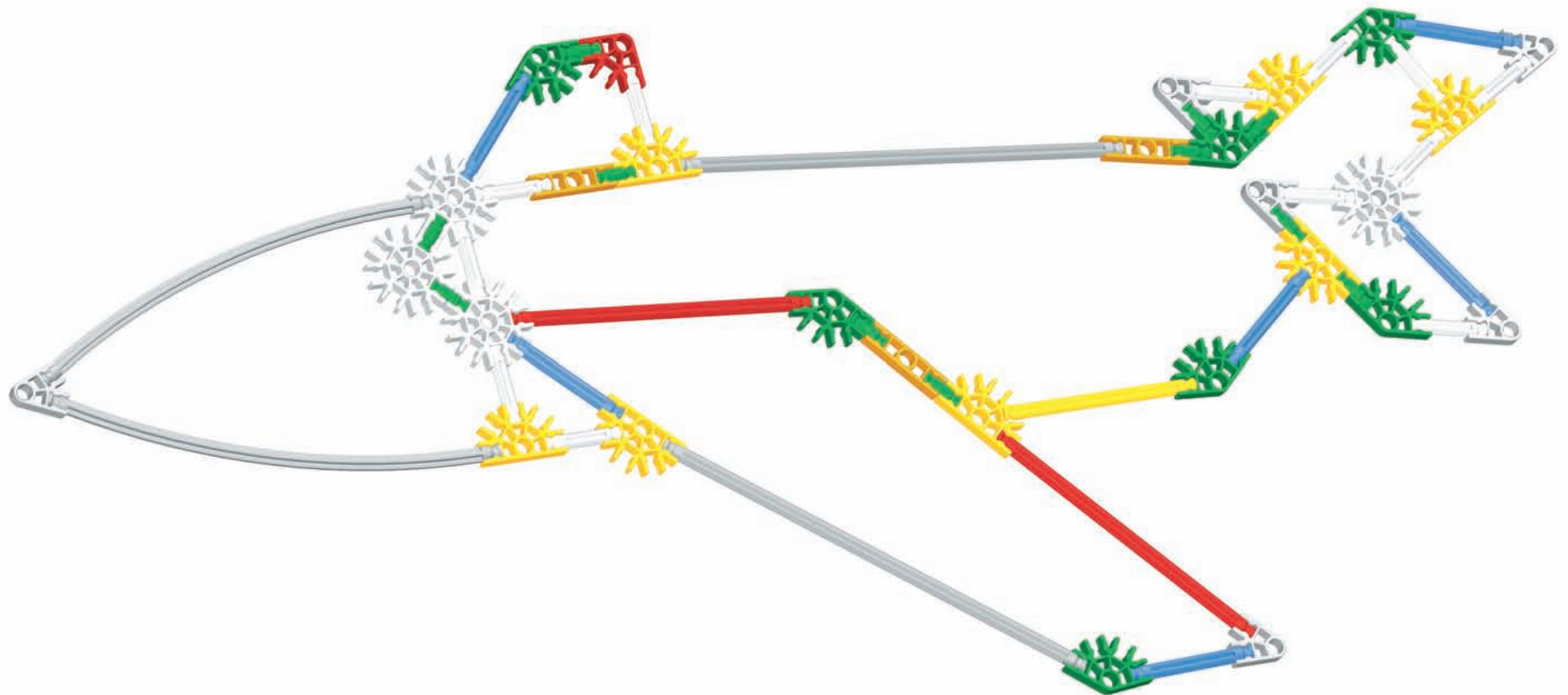

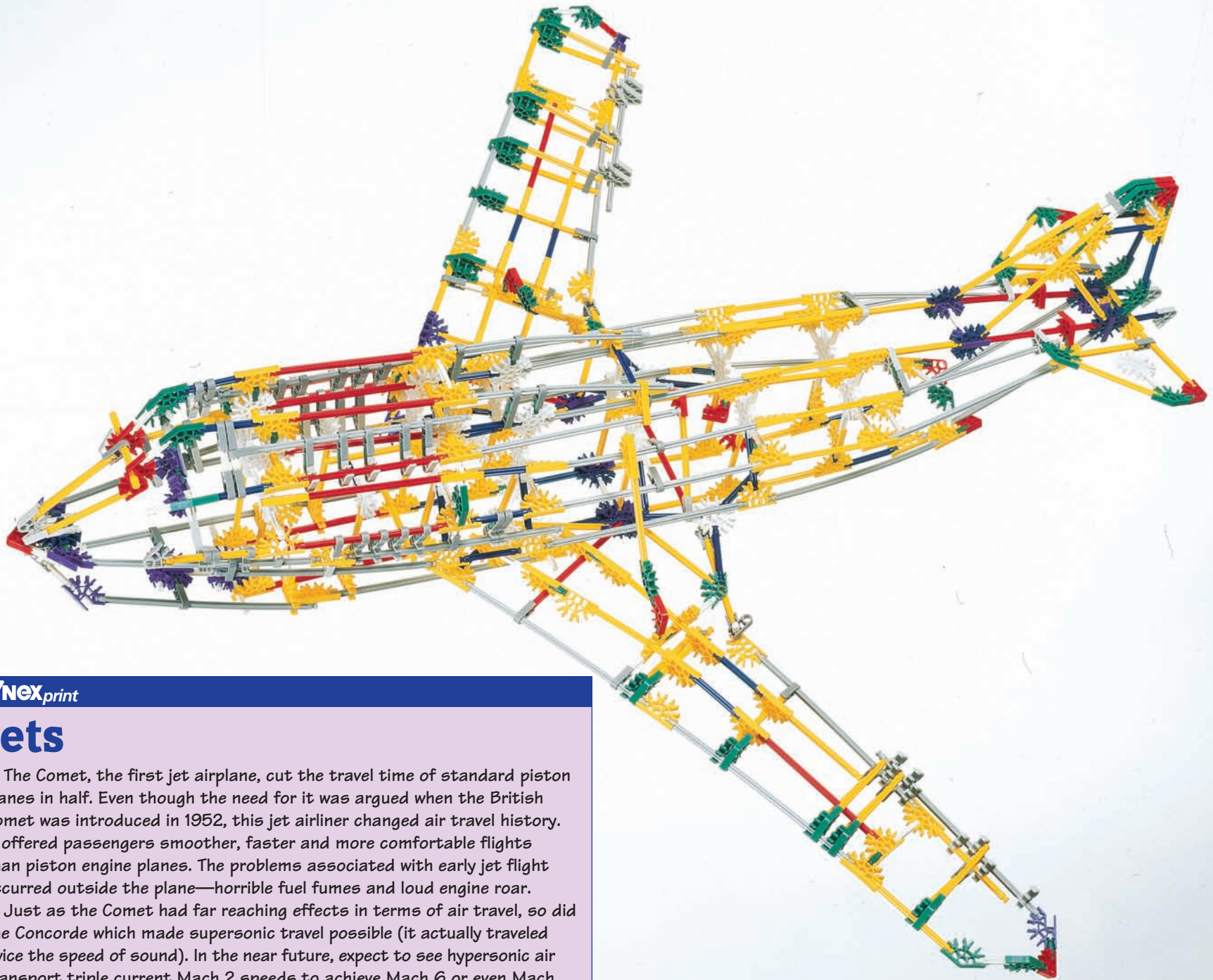

K'NEXprint

## Jets

The Comet, the first jet airplane, cut the travel time of standard piston planes in half. Even though the need for it was argued when the British Comet was introduced in 1952, this jet airliner changed air travel history. It offered passengers smoother, faster and more comfortable flights than piston engine planes. The problems associated with early jet flight occurred outside the plane—horrible fuel fumes and loud engine roar.

Just as the Comet had far reaching effects in terms of air travel, so did the Concorde which made supersonic travel possible (it actually traveled twice the speed of sound). In the near future, expect to see hypersonic air transport triple current Mach 2 speeds to achieve Mach 6 or even Mach 12. These may be the planes that fly people into space and back.

# Lighthouses

Very early lighthouses were built by the Romans, who were known for their advanced thinking and technology. These Roman lighthouses were built and used at different points along shorelines as shipping and boating aids.

Lighthouses were often built from stone in stepped patterns. They were lit by fire, usually made from wood and tar-like substances, at the top of the buildings. Today, lighthouses are still used to provide direction, guidance and warning to seafaring vessels caught in poor weather conditions or dangerous waters.

The sixth wonder of the ancient world was a lighthouse built on Pharos, the largest island near the mouth of the Nile River. This lighthouse, the largest in the world, lasted 1500 years before being destroyed in an earthquake in the 13th century.



# Lunar Modules

The Lunar Module (LM, pronounced "lem") was built to tow astronauts between the Command Module and the moon and to provide living and working quarters while on the moon. The LM, which is two small ships fitted together, had a peculiar, insect-like shape. Its "eyes" were two triangular windows; it had long, spidery legs with dish-shaped feet that served as landing pods. It also had antennae that stuck out from all sides like feelers.

The module's lower half held its legs, landing gear and descent engine which slowed its free fall for a gentle landing. The descent stage carried the ascent stage, the astronauts and their equipment to the moon. The ascent stage returned the astronauts from the moon to the Command Module. Once the astronauts were safely back on the Command Module, the ascent stage of the LM was left to orbit the moon.

3	4	3	24
4	4	9	13
9	11	24	6
			1

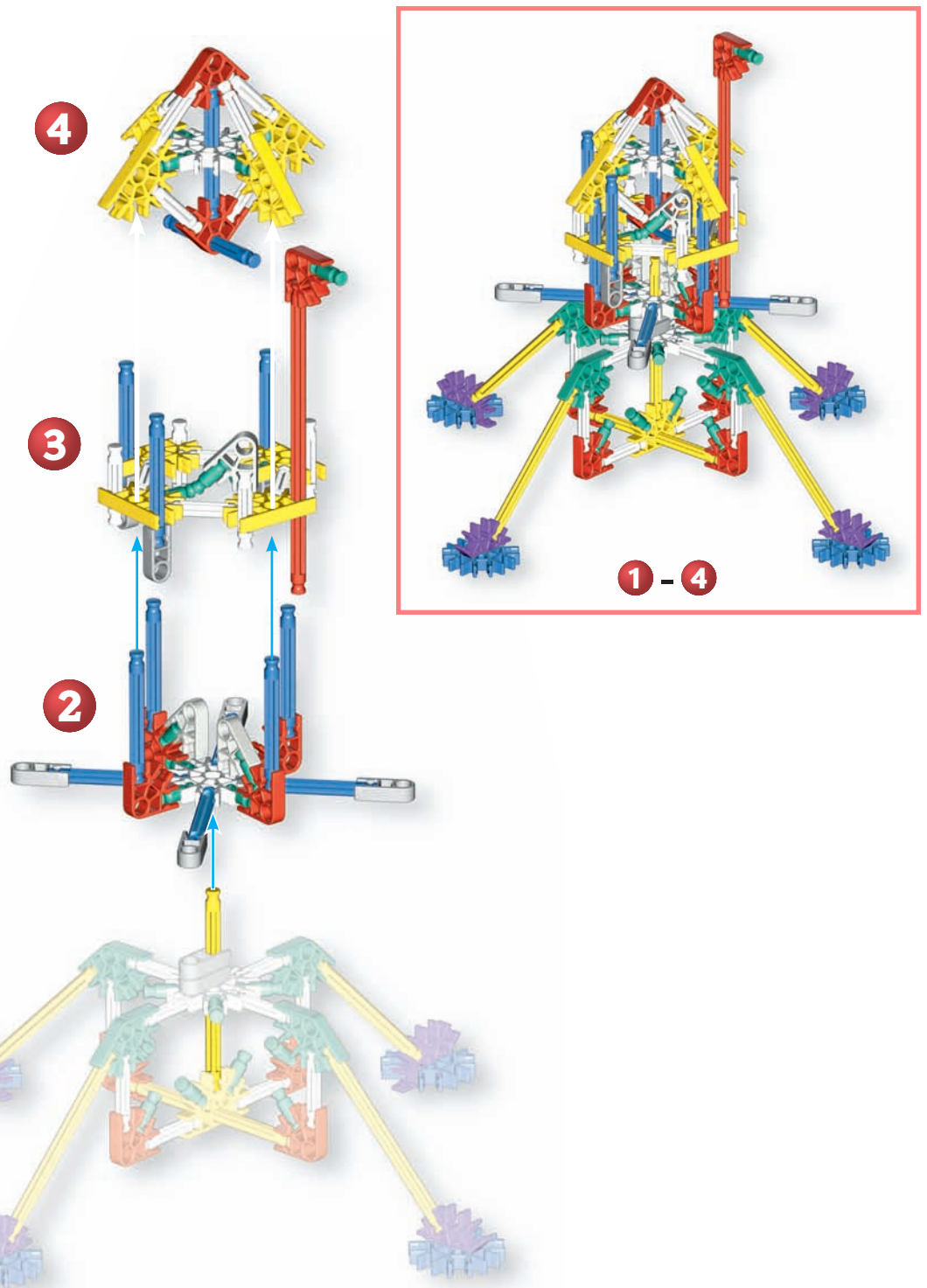
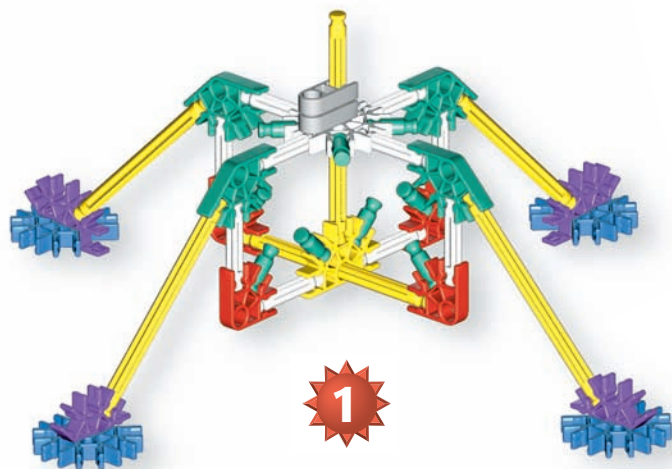

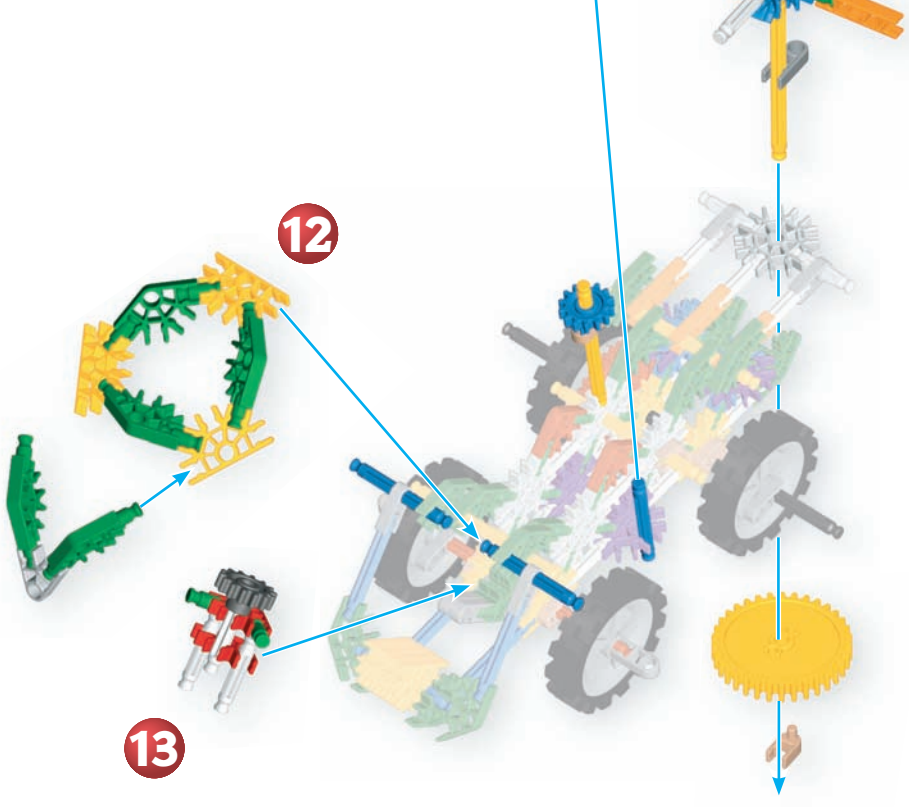
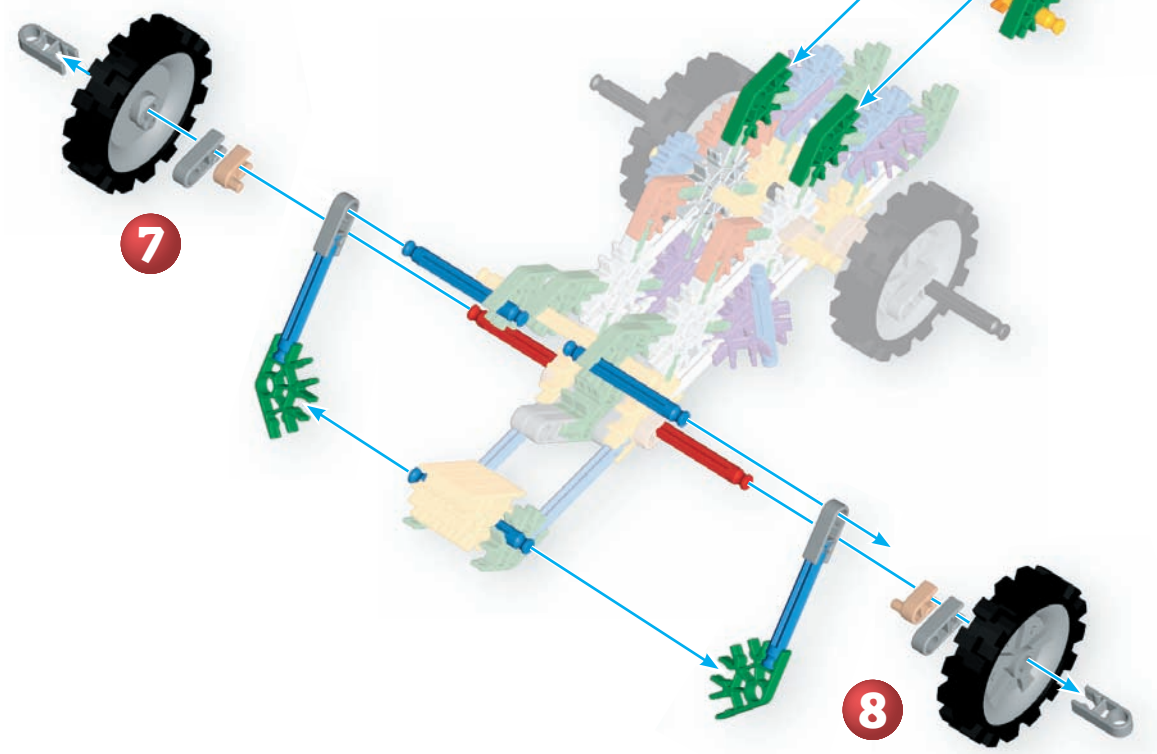
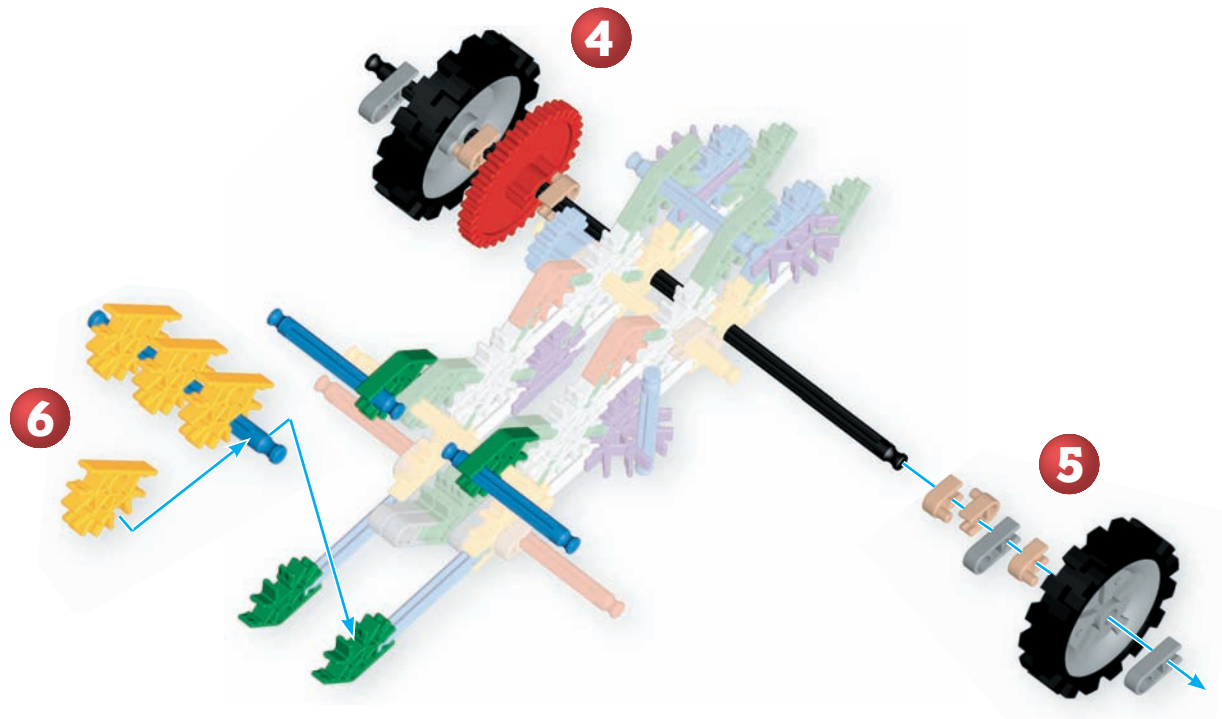
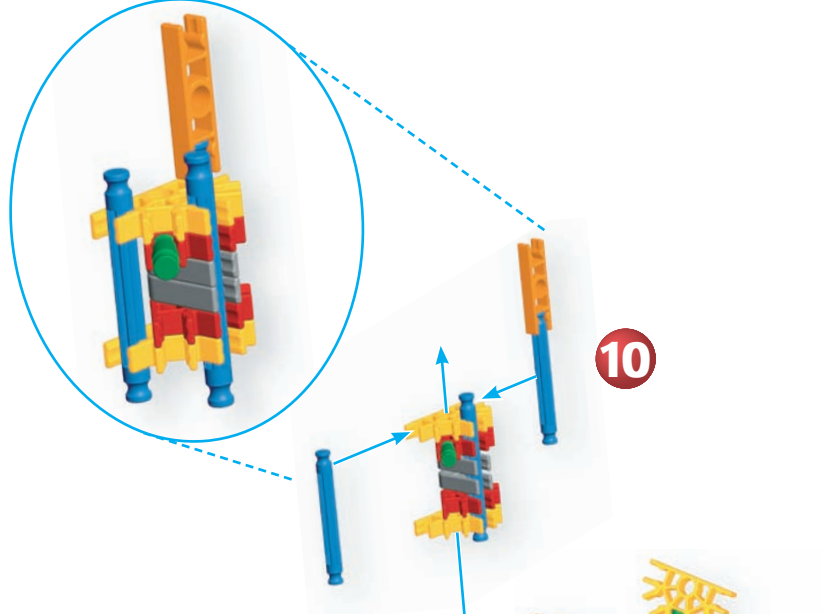
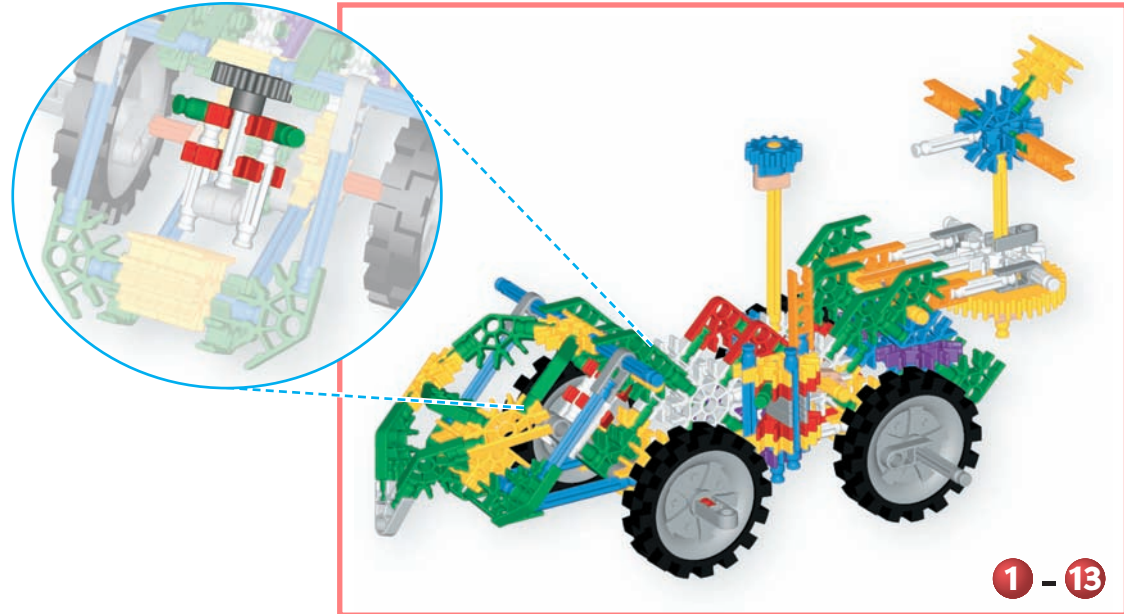
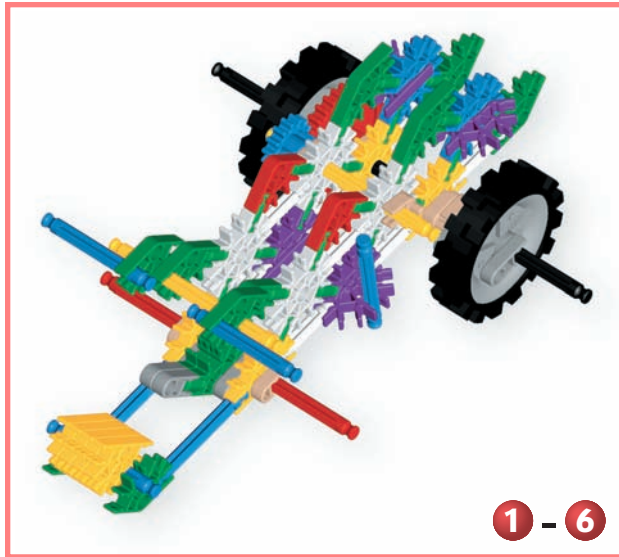

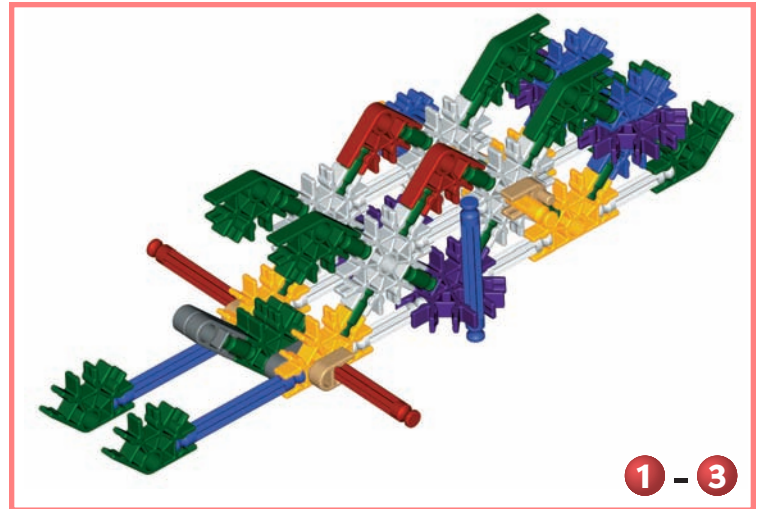
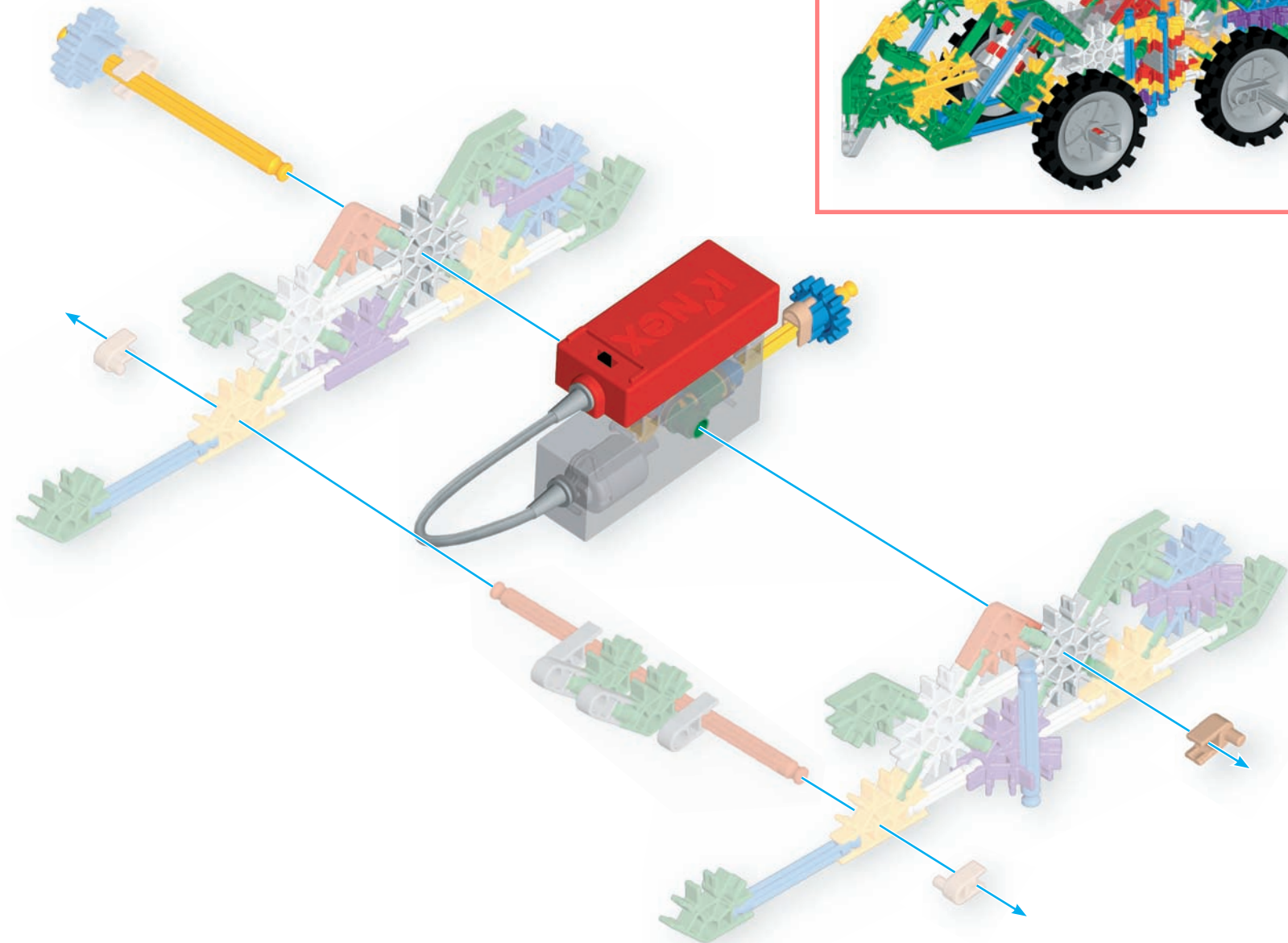























1 - 3

**K'NEXprint**

## Moon Rovers

Due to the limitations of their spacesuits, astronauts were only able to spend two-and-a-half hours on the Moon's surface before having to return to the Lunar Module cabin. The last three Apollo missions carried a battery-powered buggy called a Lunar Rover used for driving over the surface of the moon. The vehicle folded out from a storage bay in the descent stage (lower half) of the Lunar Module.

The Lunar Rover had wire mesh tires to help the vehicle grip the moon's dusty surface. It let the astronauts explore more area than if they had to travel on foot. The Rover carried a TV camera, communications antennae, scientific equipment, and a portable life support system. Its radio equipment allowed the astronauts to communicate with Mission Control on Earth.

4 	6 	40 	2 
4 	21 	17 	1 
5 	6 	12 	2 
4 	1 	5 	1 
14 	6 	1 	1 
	18 	1 	(optional)
	11 		

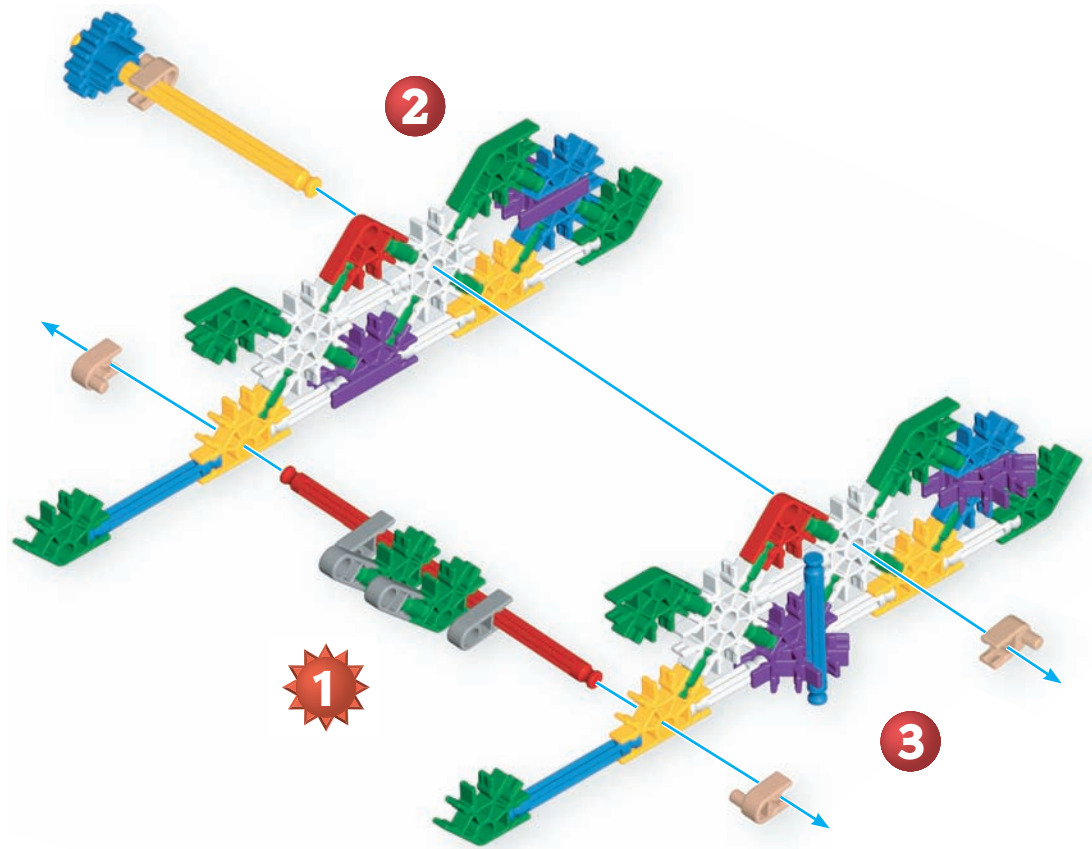

# Multiple Arch Bridges

Bridges were built to help people cross barriers more easily and quickly. There are three major types of bridges—the beam bridge, the suspension bridge and the arch bridge.

The arch bridge is considered the first great architectural invention. Arch bridges provide a long span with high clearance over water or other

barriers with no piers to block traffic underneath. Wedge-shaped stones fit snugly together and push up against the top center stone, called the keystone. The stones are held in place by the pressure of the weight (live and dead load) of the bridge. The roadway may be on top of the arch support or hung below it.



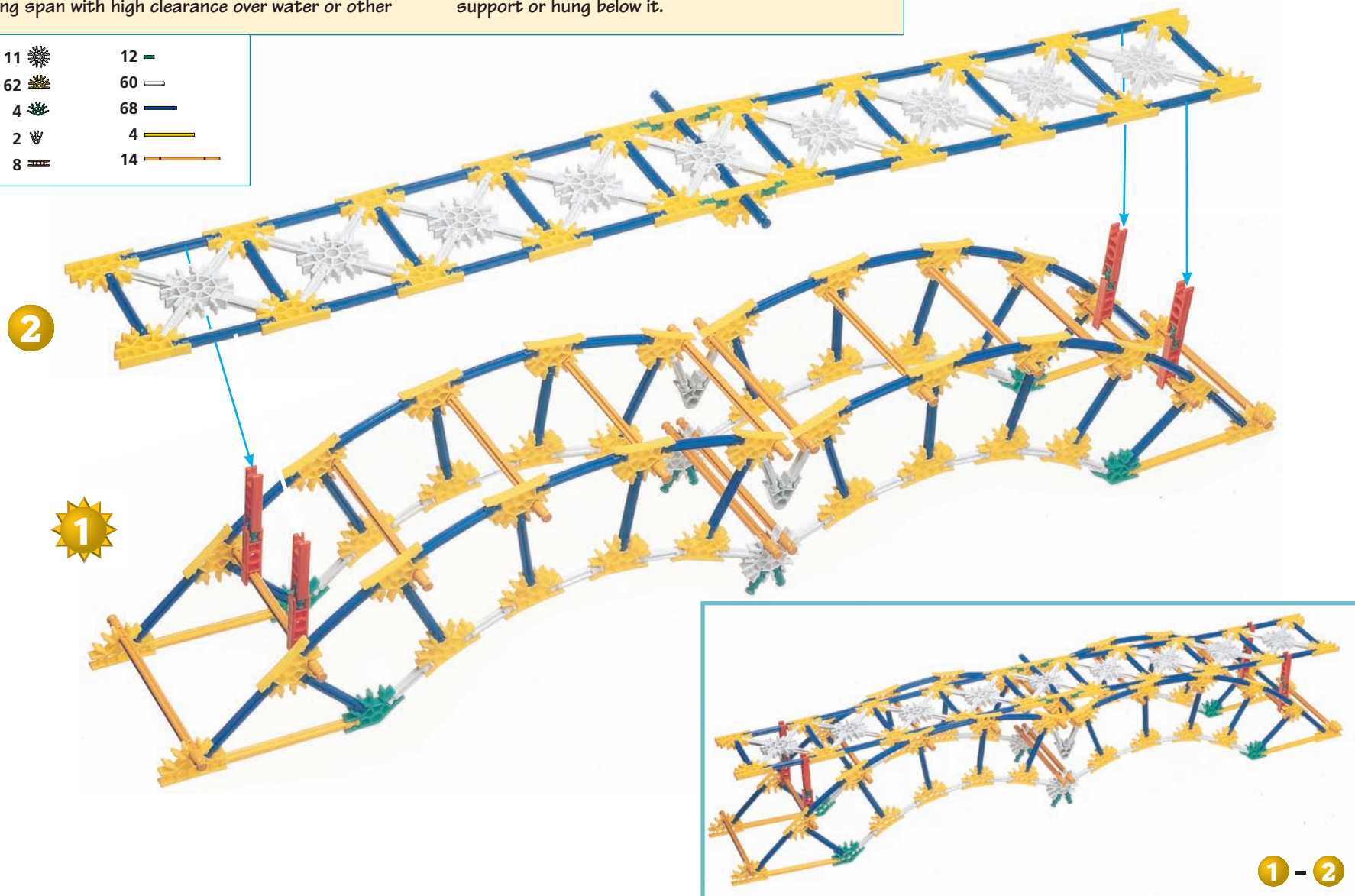

- |    |  |    |  |
|----|--|----|--|
| 11 |  | 12 |  |
| 62 |  | 60 |  |
| 4  |  | 68 |  |
| 2  |  | 4  |  |
| 8  |  | 14 |  |



# Ocean Liners

Before air travel became popular and affordable, ocean liners served as the primary way to travel to distant locations in comfort and luxury. Ocean liners were designed for deep water voyages. As an outgrowth of the shipping industry which used the same ocean routes or lines to transport cargo and then passengers, the ocean liner acquired its name.

From the 1840's through the 1930's, these large pleasure ships with huge hulls transported millions of passengers, often up to 2,000 per trip. They functioned as floating hotels complete with fine dining, dancing and entertainment, comfortable cabins for sleeping, games and even swimming (after 1911). Half of the crew members, as many as 800 in all, took care of passengers' needs, and the other half ran the ship itself.

10		7		14		20	
13		1		10		1	
6		2		1			

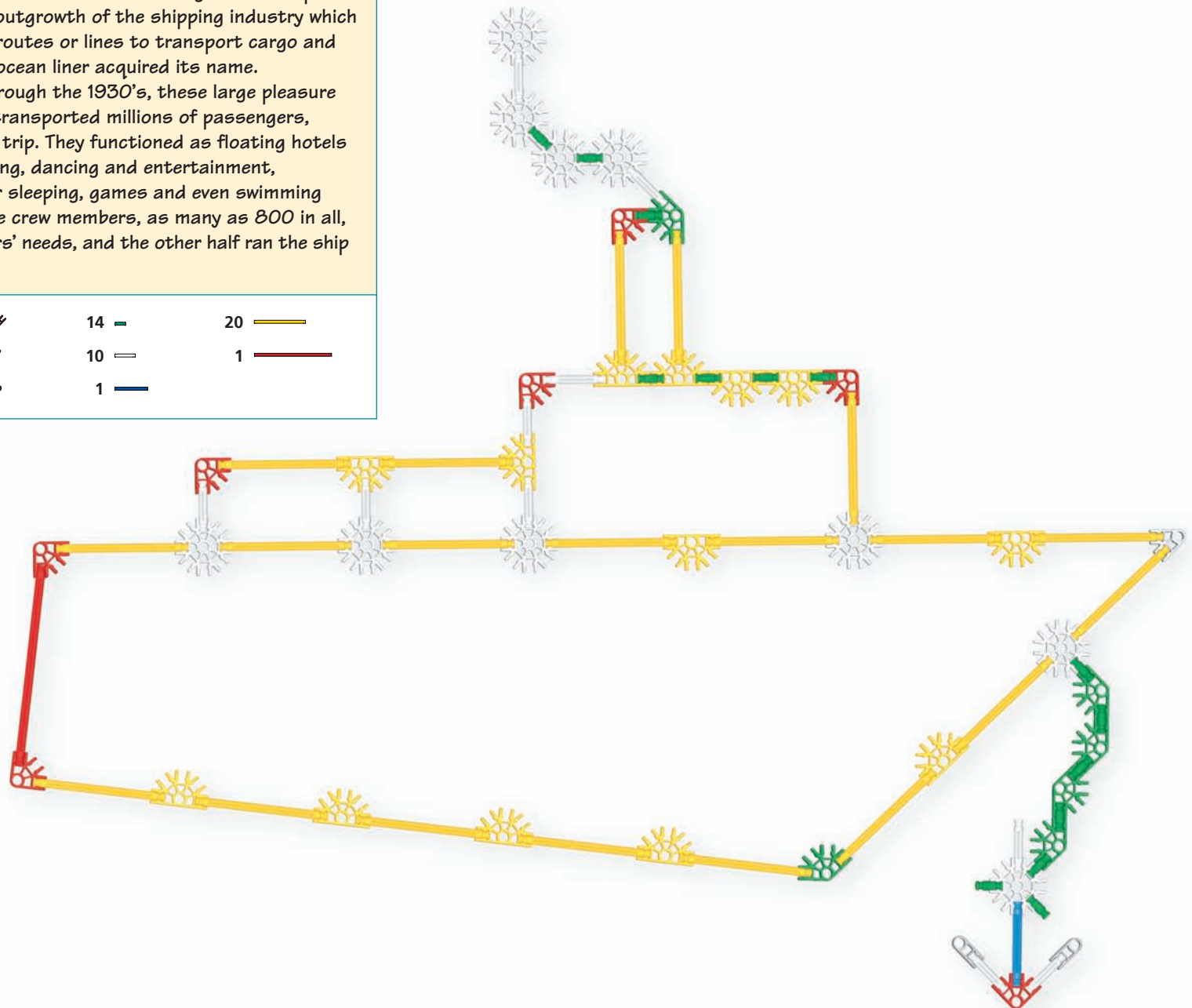

# Riverboats

The first working paddleboat was created in 1787 by adding a water wheel onto a boat built by John Fitch in the U.S. Early paddleboats had two water wheels, one on each side of the boat. The force of water spilling over the paddles on the wheel moves the boat forward along the river. The water wheels could be raised and lowered depending on how deep the water was.

In 1809, Robert Fulton invented the steam engine. The combination of the steam engine and paddleboats soon made this means of travel more efficient, as did the design of a single large water wheel. These boats traveled mainly down river, so they are often referred to as Riverboats. The first trip down the Mississippi River was in 1812. And by the 1830's, there were more than 1200 steamers working the river!

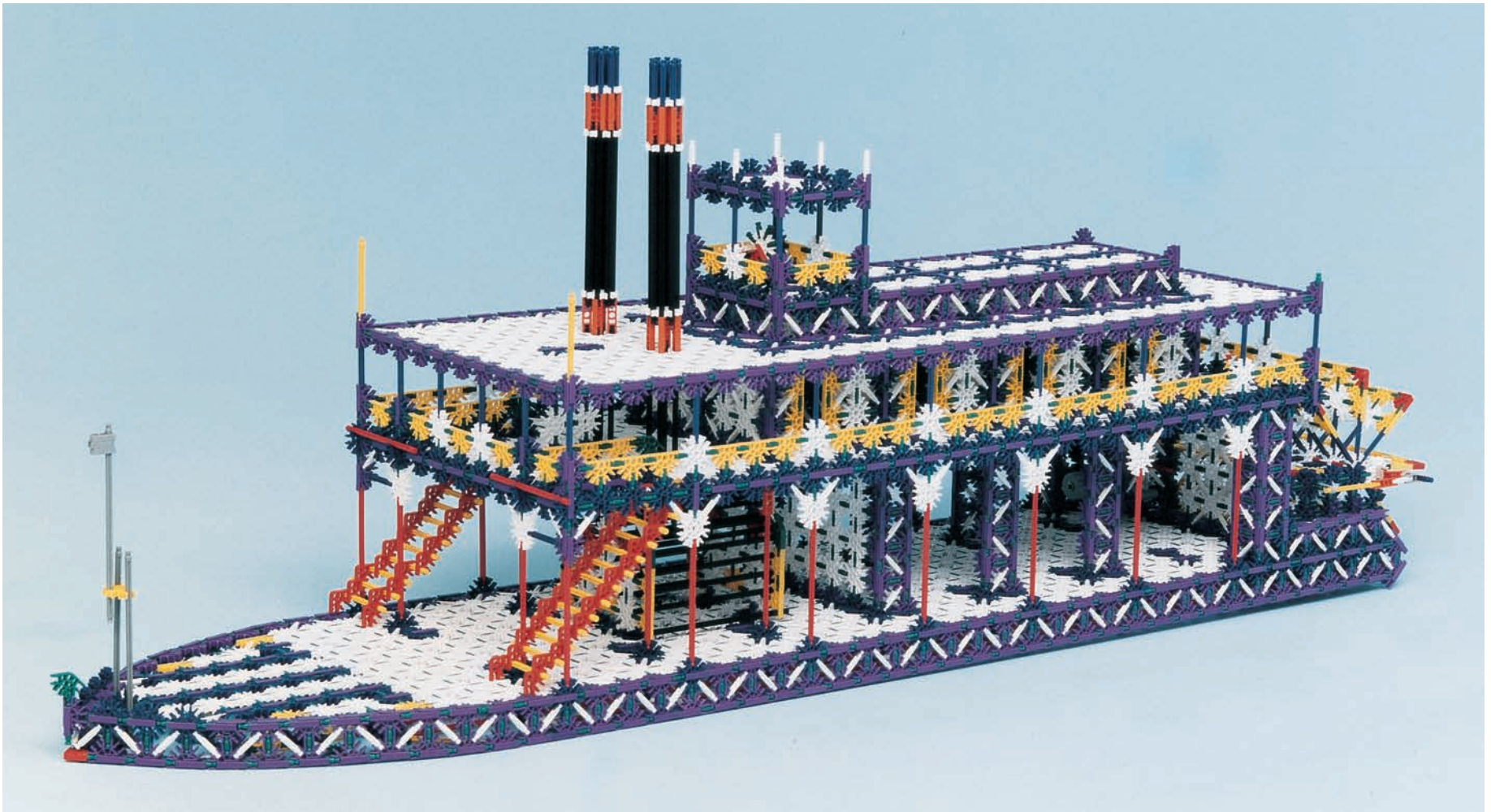

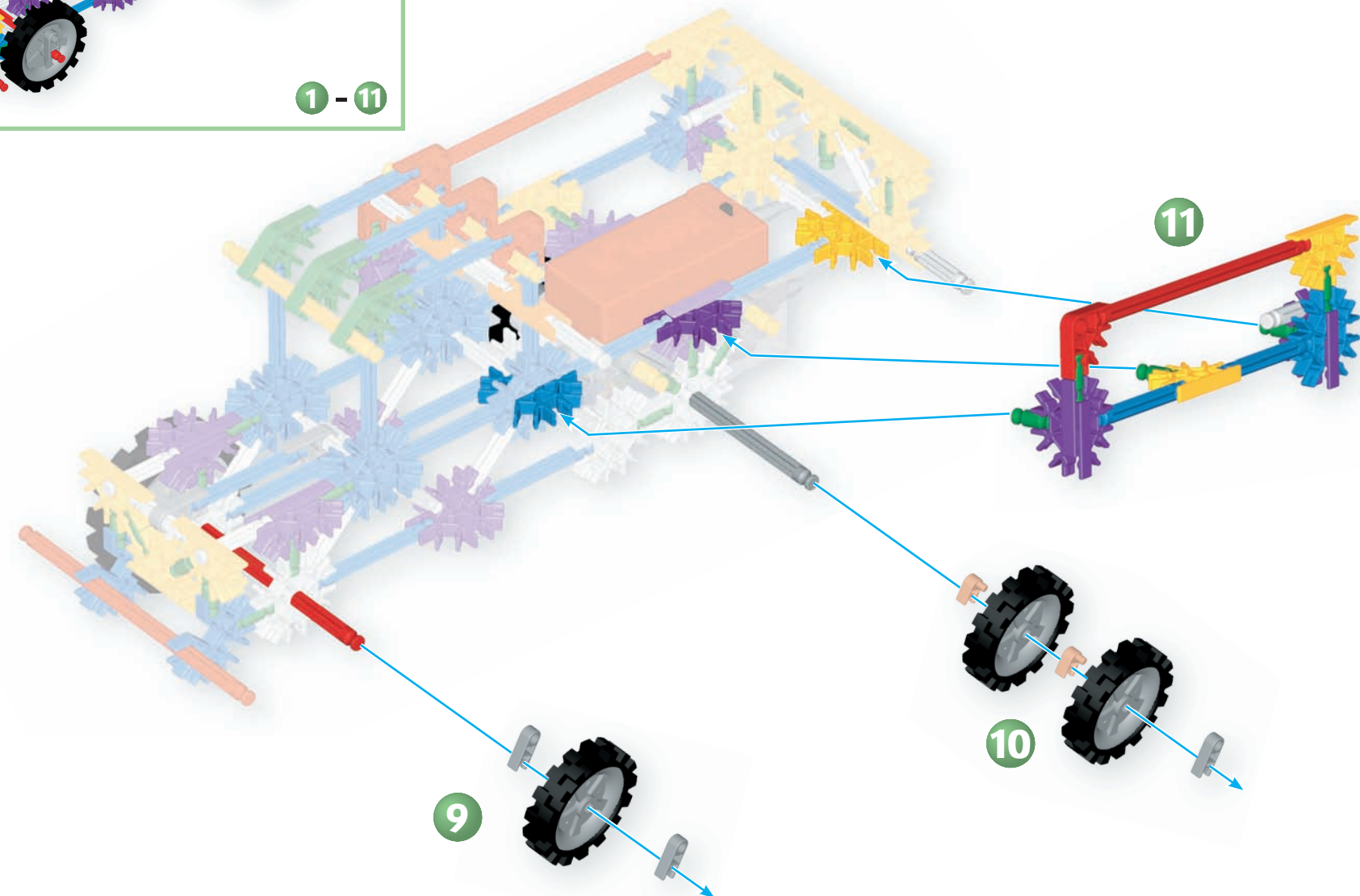
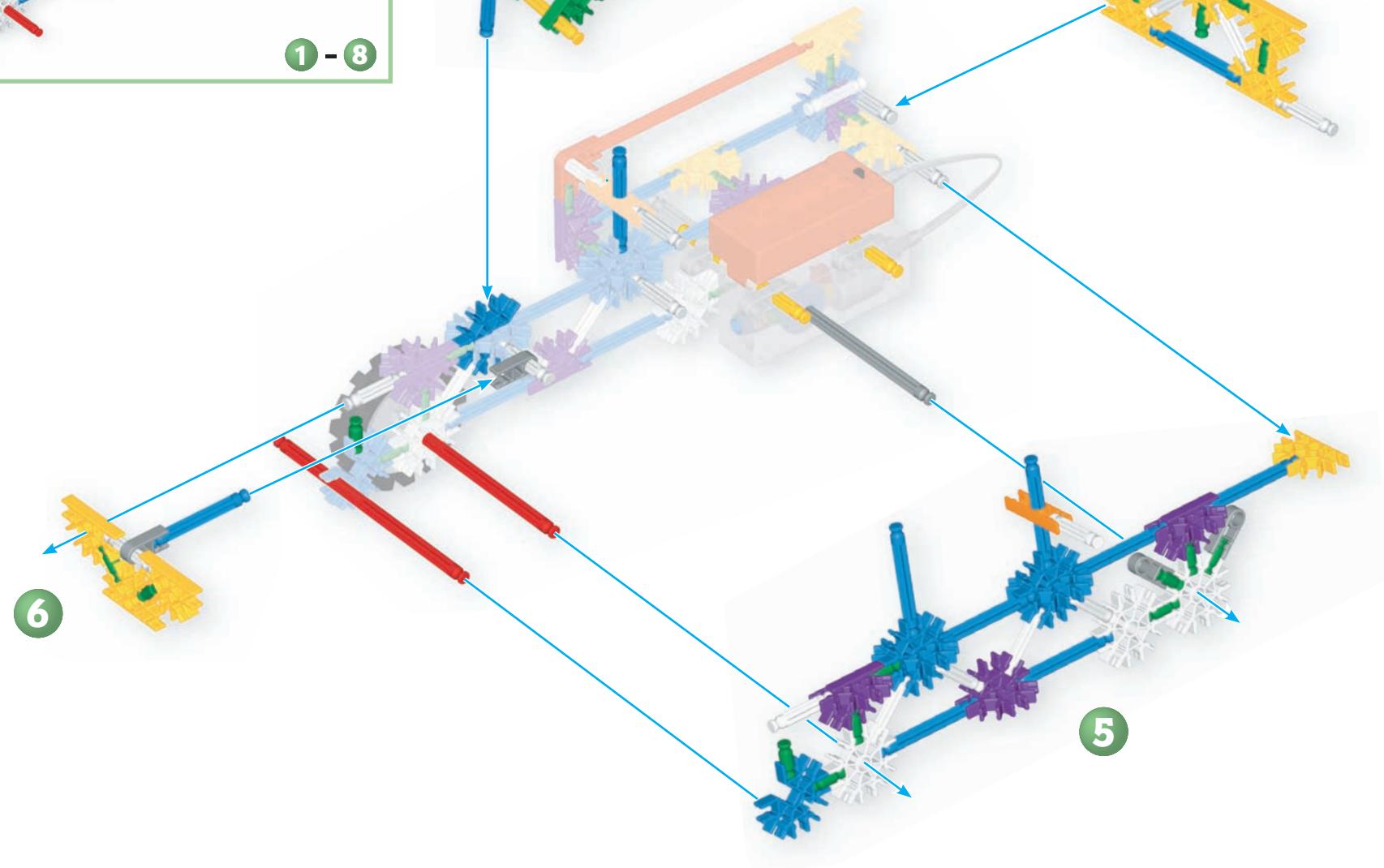
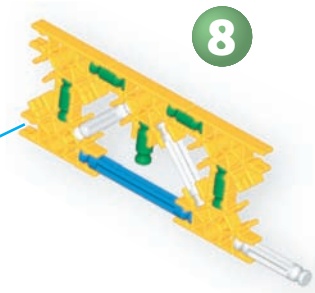
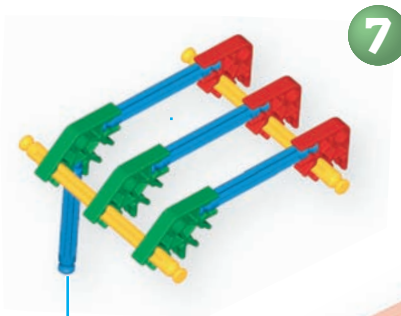
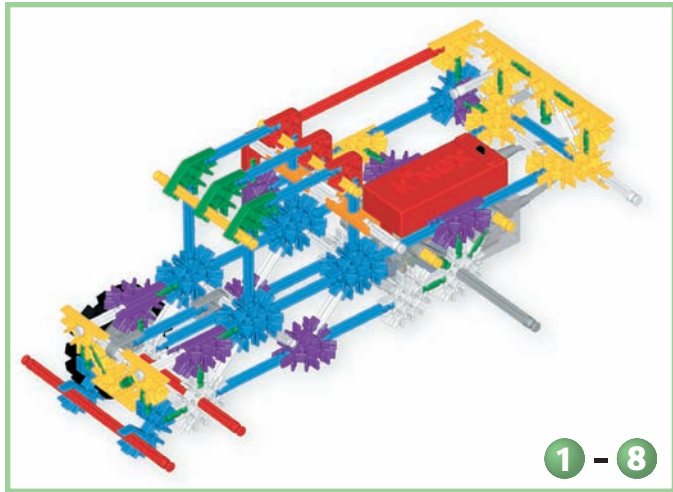

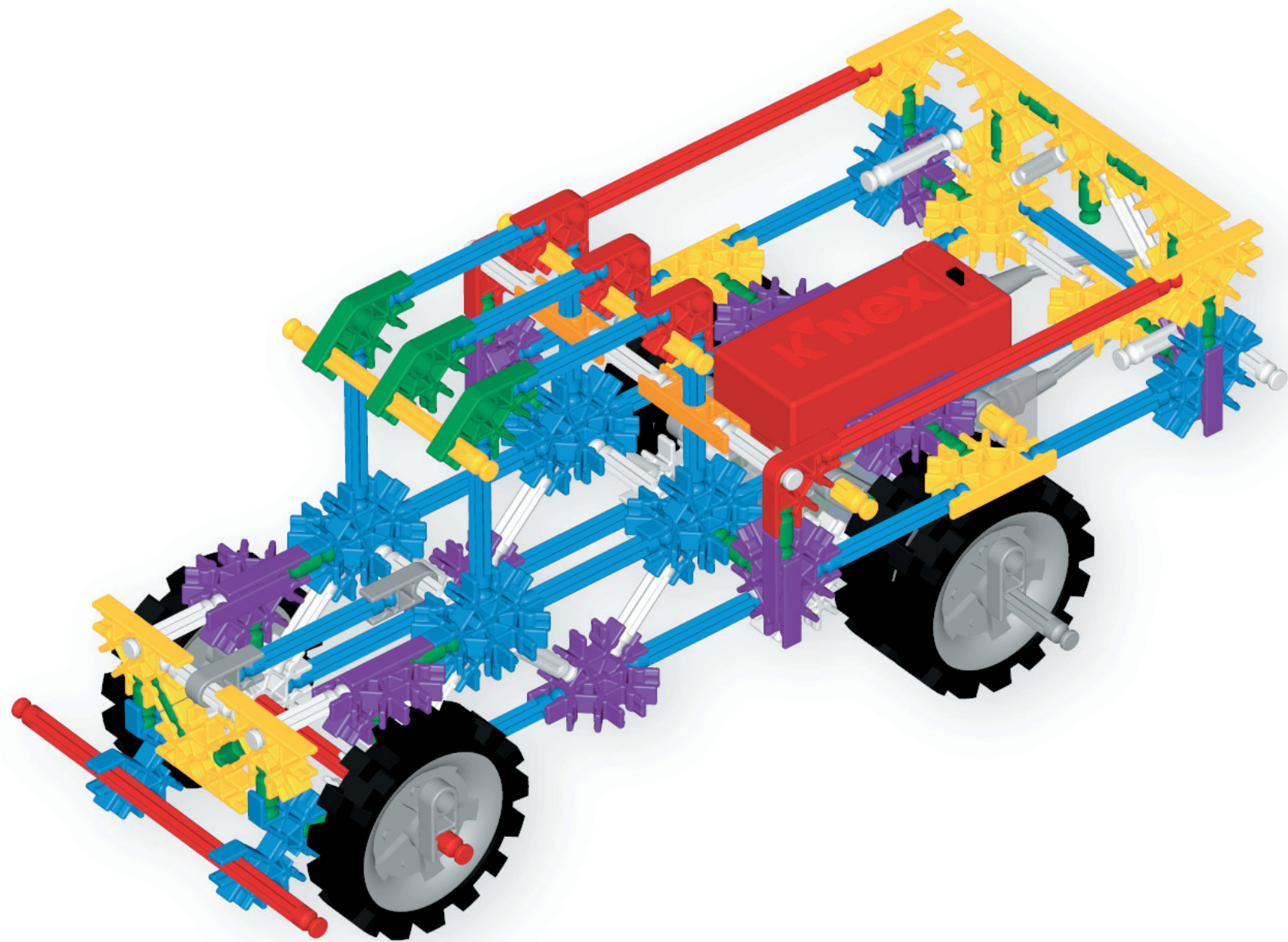

2



3

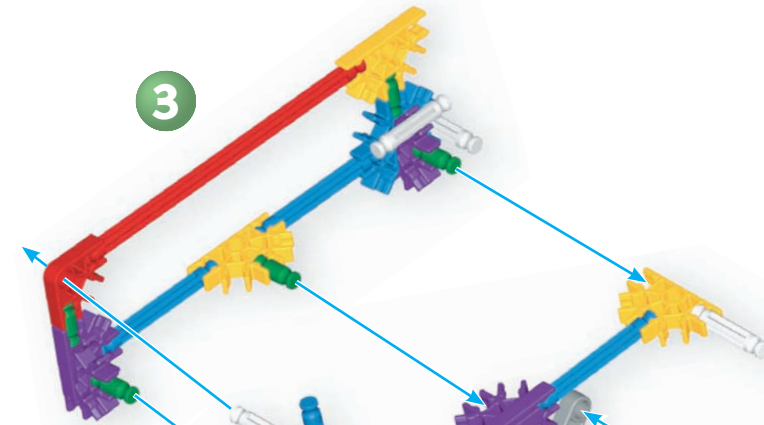

4

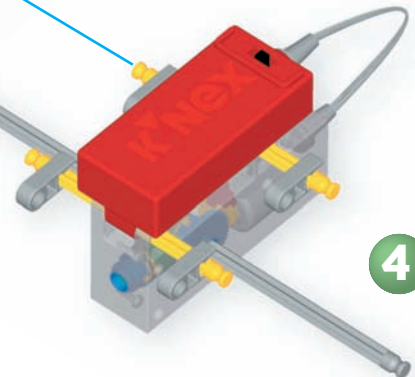

1

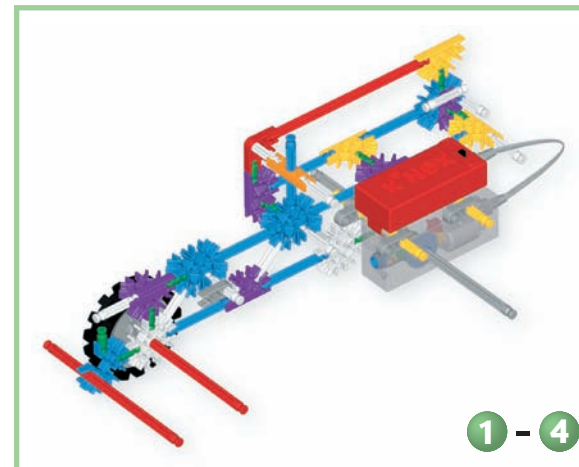
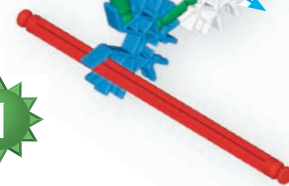

1 - 4

K'NEXprint

## Pickup Trucks

Once used mainly in rural areas for farming and hauling supplies, today pickup trucks are used by everyday drivers on city streets across the country. They usually have enclosed front cabs where driver and passengers ride, and a flat rear bed with enclosed sides and an open top. The panel which encloses the bed from behind is actually a hinged door, called a tailgate. Since the trucks were used to pick up small loads regularly, they became known as pickups.

A standard bed is about 6-8 feet (1.8-2.4 meters) long and is used for transporting materials to construction sites, making deliveries or helping people move into new homes—times when cars are not big enough to do the job. They are tough vehicles available in different weight classes, which means they are designed to carry varied loads (often called payloads). Originally designed for work not comfort, their popularity has created a demand for improvement in their ride and handling, as well as in comfort and extras.

- 1
- 6
- 6
- 6
- 12
- 14
- 18
- 3
- 5
- 16
- 2
- 4
- 33
- 23
- 23
- 4
- 4
- 1

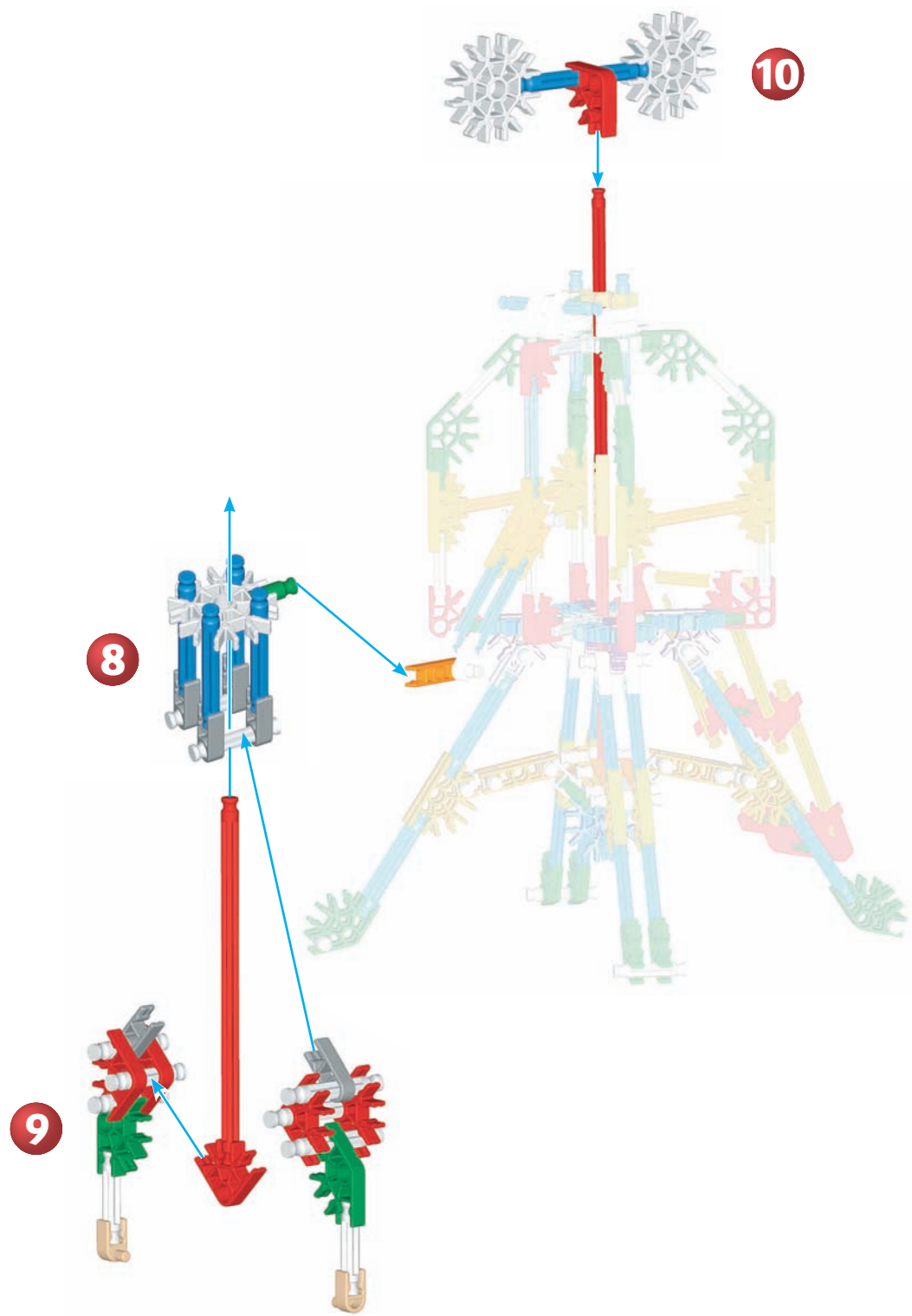

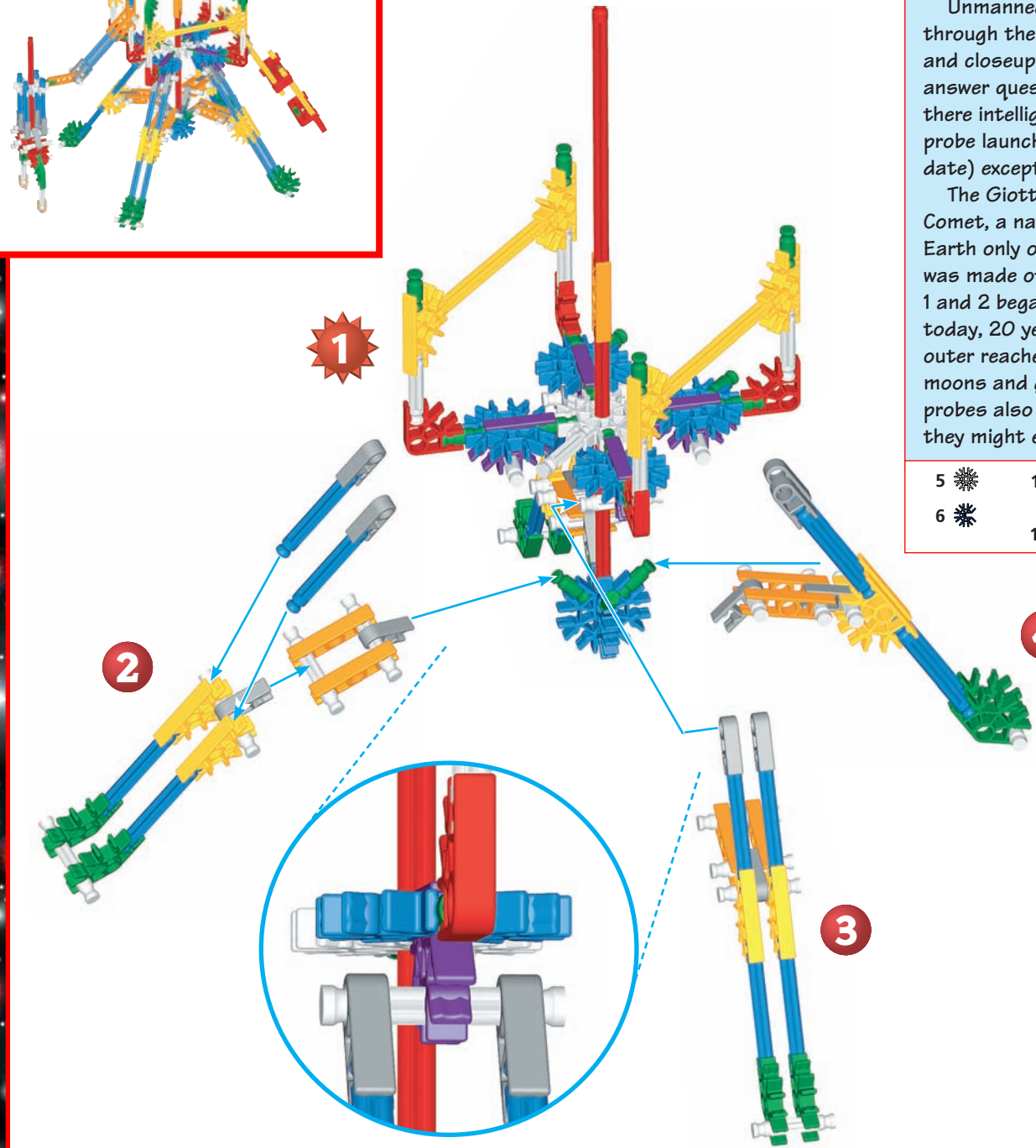
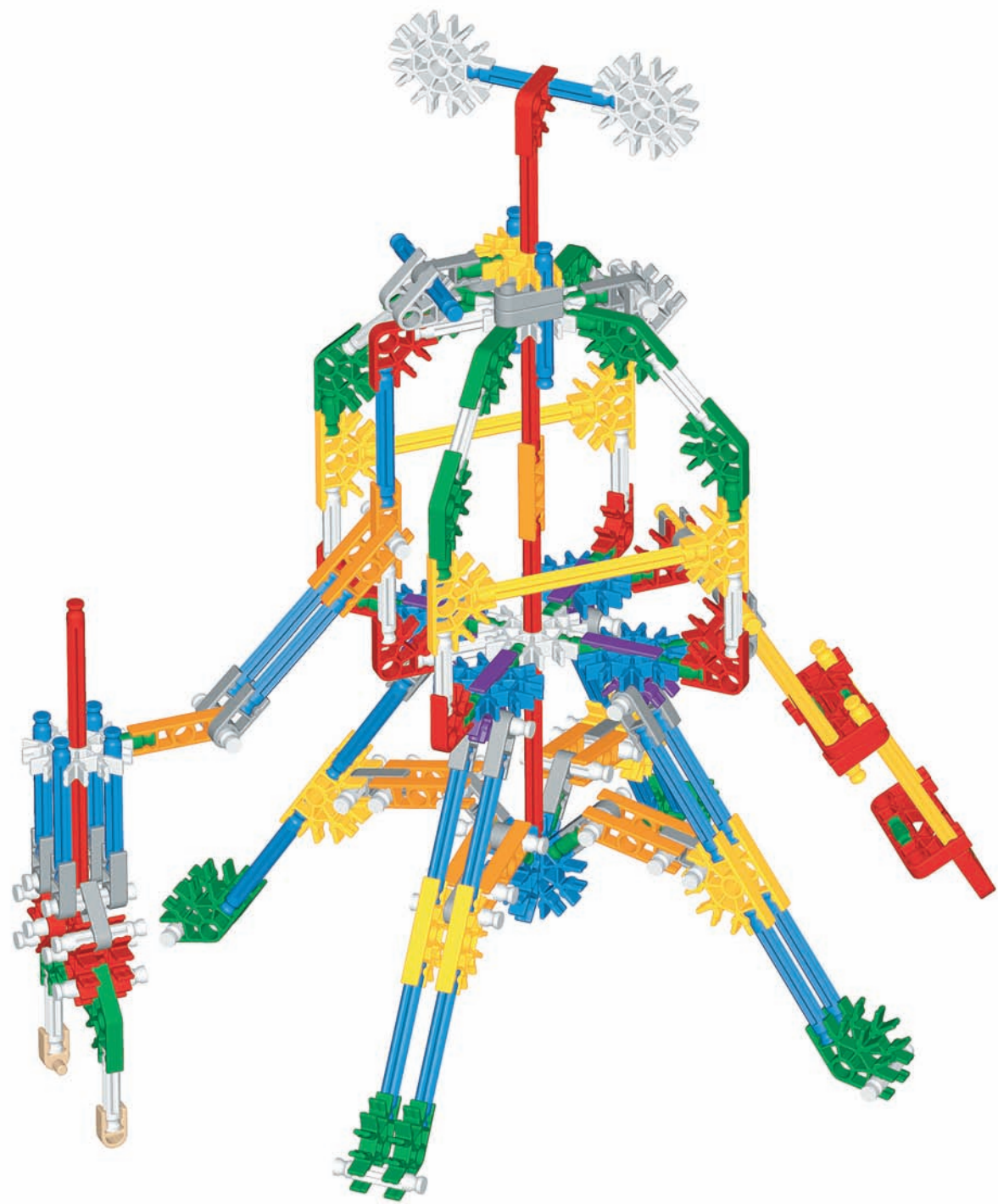

**K'NEXprint**

## Space Probes

Unmanned space probes are complex robots that travel through the solar system to explore and collect new information and closeup pictures from the areas they visit. Probes try to answer questions about space and other planets, such as, "Is there intelligent life on Mars?" Since the first successful space probe launch to the moon, probes have visited every planet (to date) except Pluto.

The Giotto probe was launched in 1985 to study Halley's Comet, a natural object that orbits the Sun and passes the Earth only once every 76 years. It discovered what the comet was made of and why it has its look and shape. In 1977, Voyagers 1 and 2 began a long distance trip into space which continues today, 20 years later. Voyagers 1 and 2 were sent to explore the outer reaches of the Solar System. There they found strange moons and giant planets surrounded by poisonous gases. The probes also carry a message from Earth for any space dwellers they might encounter.

5	13	22	13	29	7
6	4	4	34	44	3
	18		2	27	

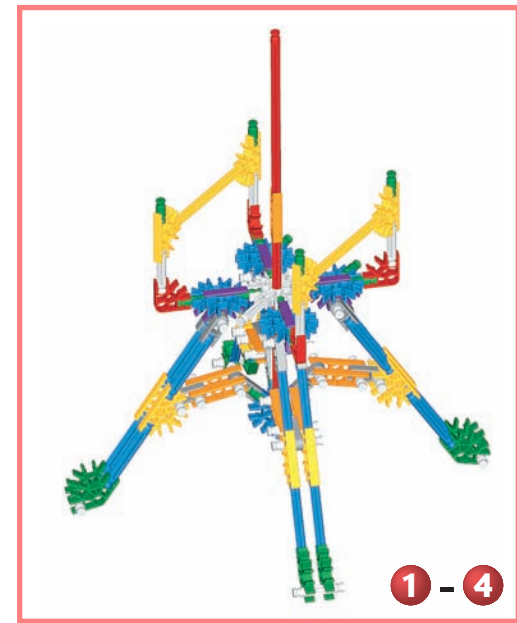

# Radar Stations

Radar is a system which “bounces” radio waves off a target to draw a picture of it. A radar station or tower is the tool that Mission Control uses to track the flights of all spacecraft, manned or unmanned, and to find garbage and debris floating in space, thereby averting collisions. Each station sends out coded signals which bounce off the spacecraft or debris and send back information. Radio waves travel 186,000 miles (299,274 km) per second so ground crews learn where a craft is by using the time the signal took to reach it, bounce off and travel back to Earth.

To receive signals returning from great distances, three stations, in California, Spain and Australia, use special bowl-shaped antennae. As the Earth turns, each antenna gathers the signals—usually two stations are within range at one time. They check for signs of trouble on a spacecraft and calculate its range, speed, altitude and direction from the Earth’s center. NASA’s tracking network keeps tabs on unmanned satellites in deep space, unmanned ships in near space and tracks and communicates with manned vehicles.

- 1 
- 2 
- 2 
- 8 
- 2 
- 3 
- 8 
- 10 
- 2 
- 1 
- 20 
- 2 
- 10 
- 21 
- 15 
- 3 

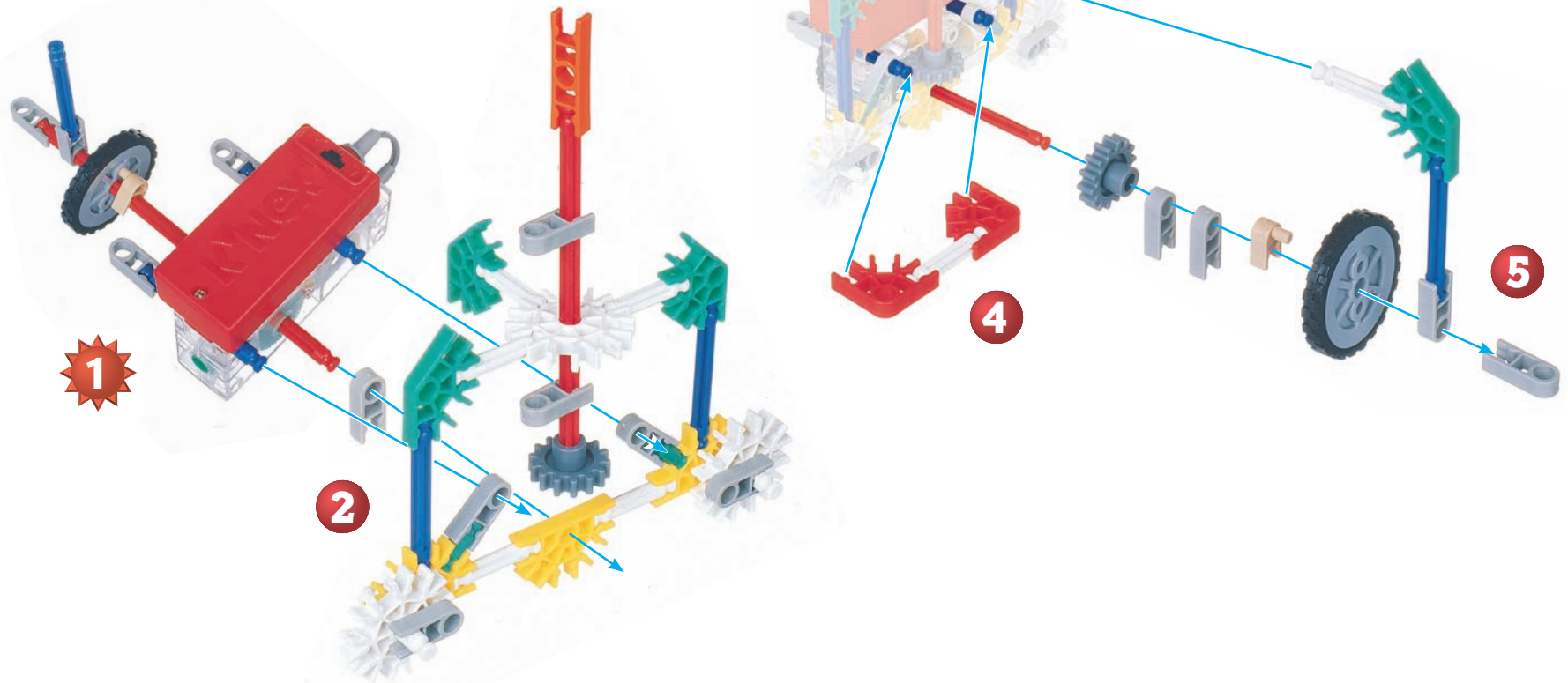

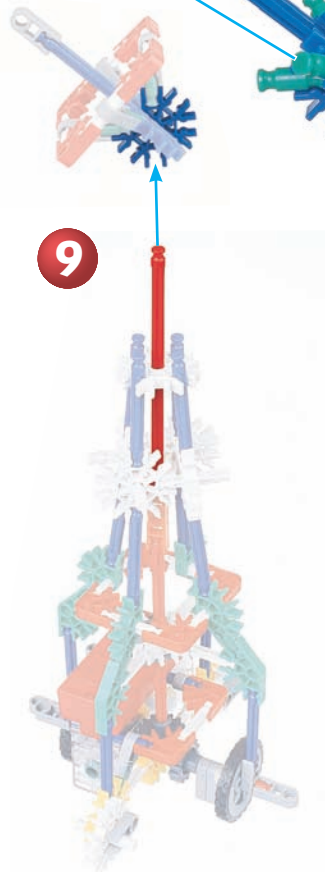
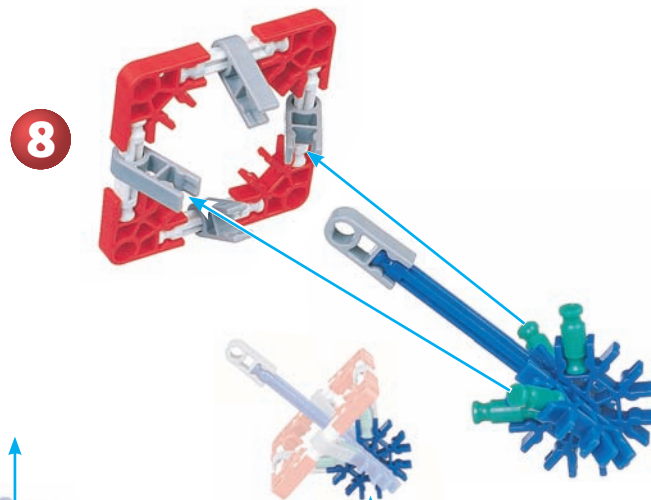
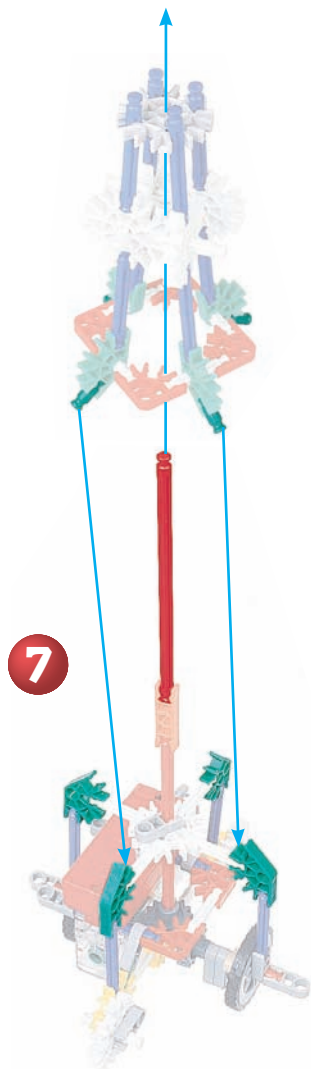

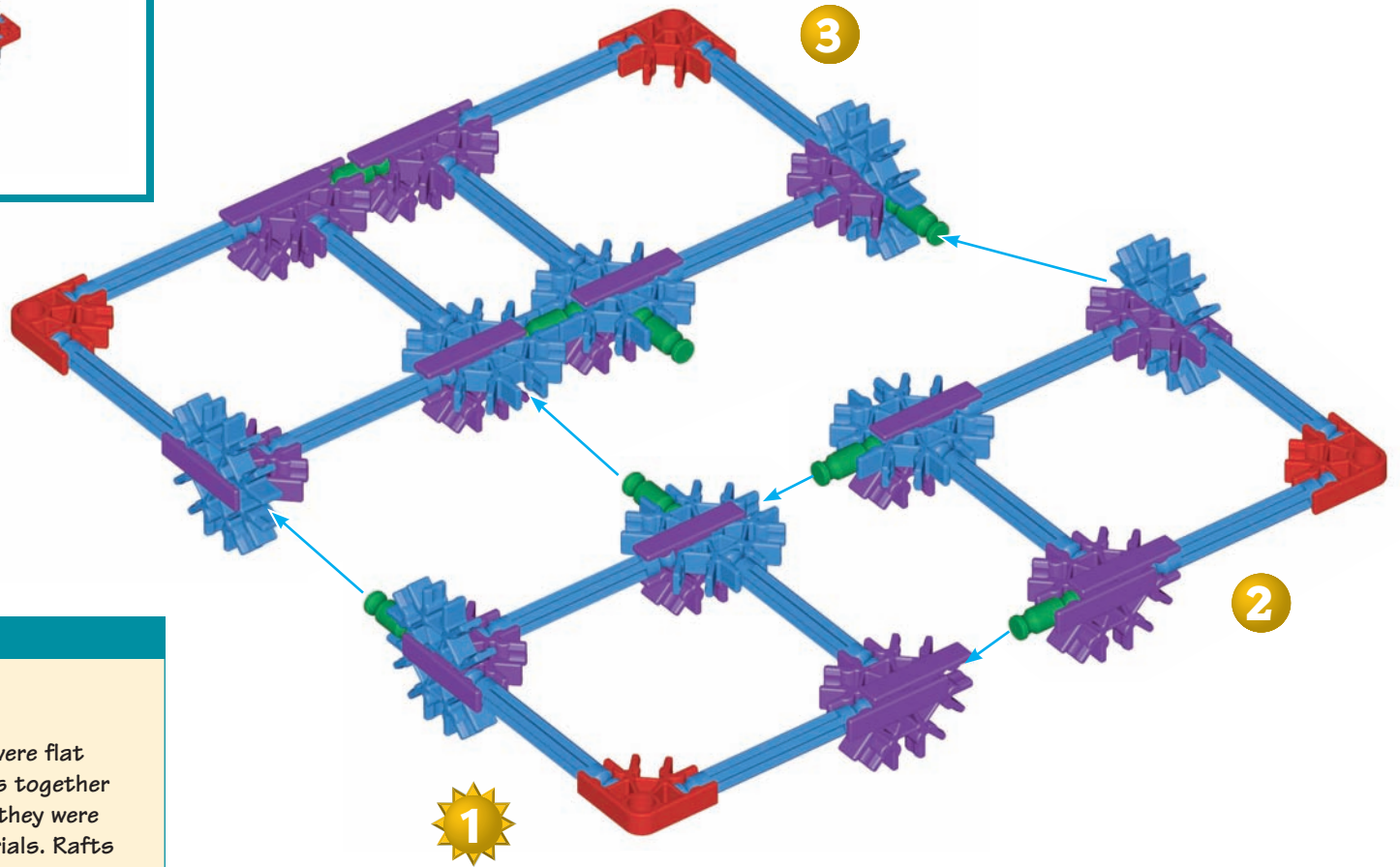
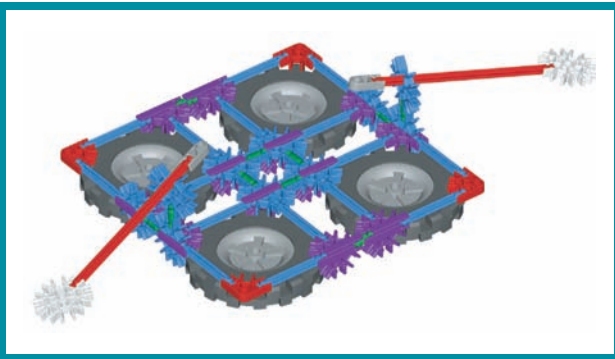

K'NEXprint

## Rafts

The first and simplest boats were flat rafts probably made by tying logs together with vines. They floated because they were made of naturally bouyant materials. Rafts drifted on top of water and were generally sturdy enough to cross a calm river or lake but were not safe for rougher waters.

Oars, a type of lever, were an addition to this early mode of transportation. The rower pulled one end of the oar, causing the broad blade to catch the water. The blade then became a pivot point or fulcrum. The force applied to the oar propelled the raft (boat) backwards. This work required human muscle to move and steer the raft.

2		2		4	
10		10			
16		16		4	
4		2			

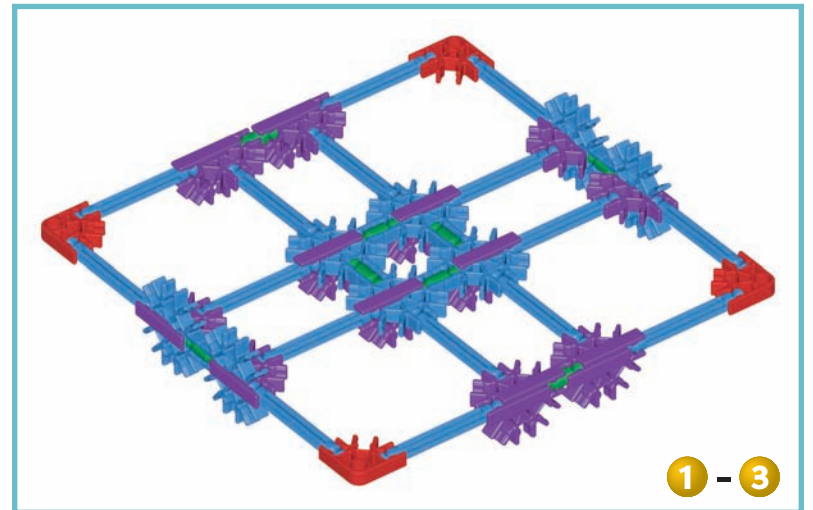

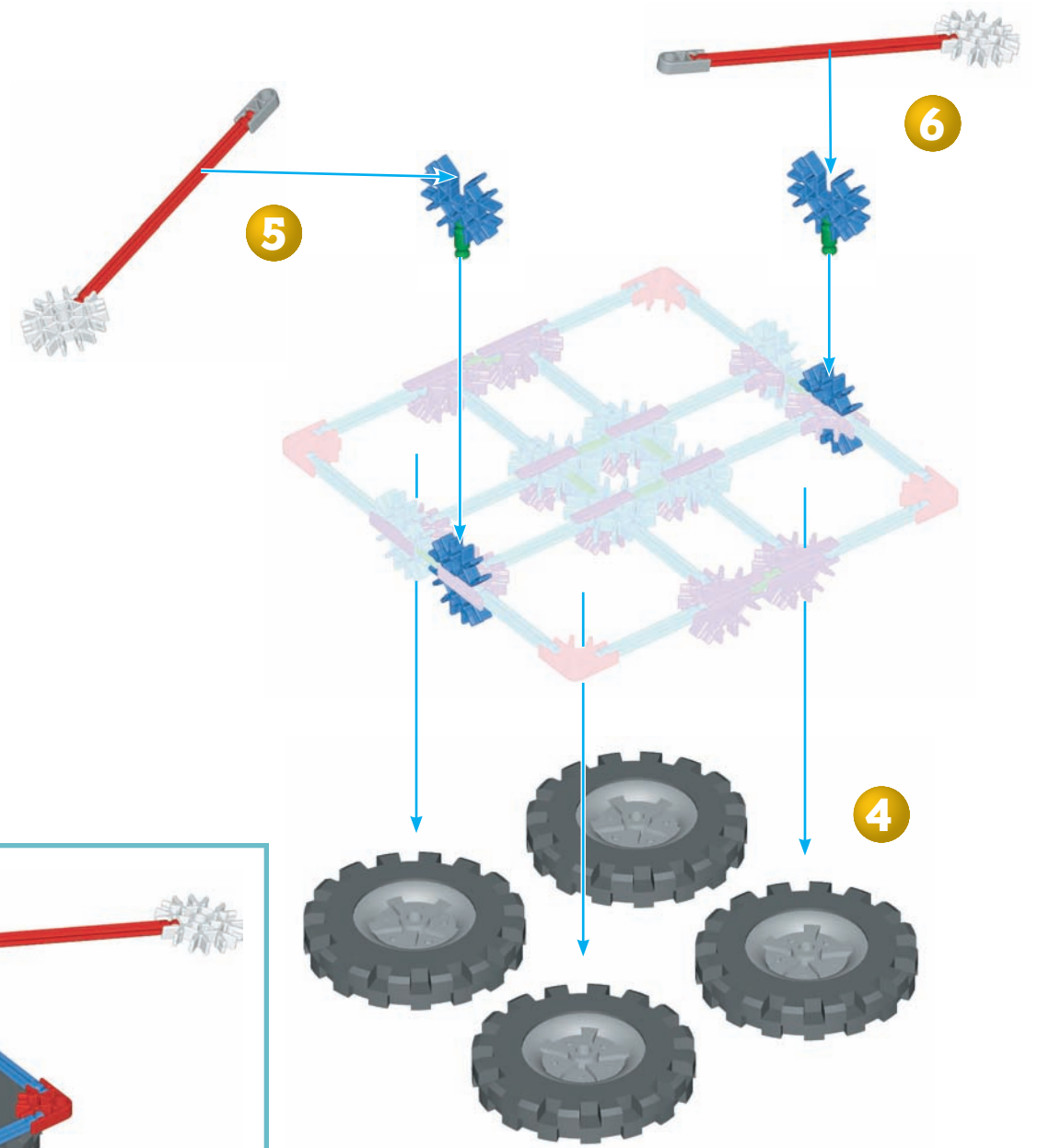
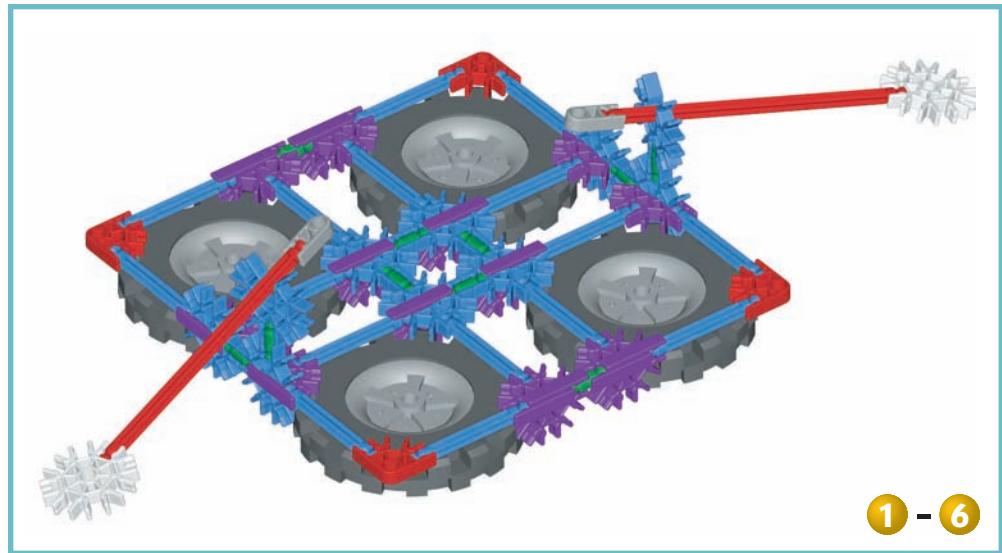

# Rescue Choppers

Helicopters are versatile vehicles that can move in any direction, stand still (hover) and fly or land almost anywhere. They can travel within very close quarters and land on relatively small spaces called heliports, which may even be the tops of tall buildings in the city! Lightweight helicopters carry as few as two people, an average copter carries 10-30 people and some troop carrier copters can hold more than a hundred.

While helicopters assist people in all types of work, they have a tremendous impact as rescue vehicles. They are able to save victims caught in especially difficult situations and places that are otherwise unreachable. Their landing and hovering capabilities make helicopters especially helpful at rescuing drowning victims, climbers stranded on mountains, people cut off by forest fires, people on roofs of skyscrapers with no other escape, and other emergency circumstances.

- 1
- 2
- 1
- 5
- 6
- 1
- 9
- 3
- 6
- 9
- 6
- 1

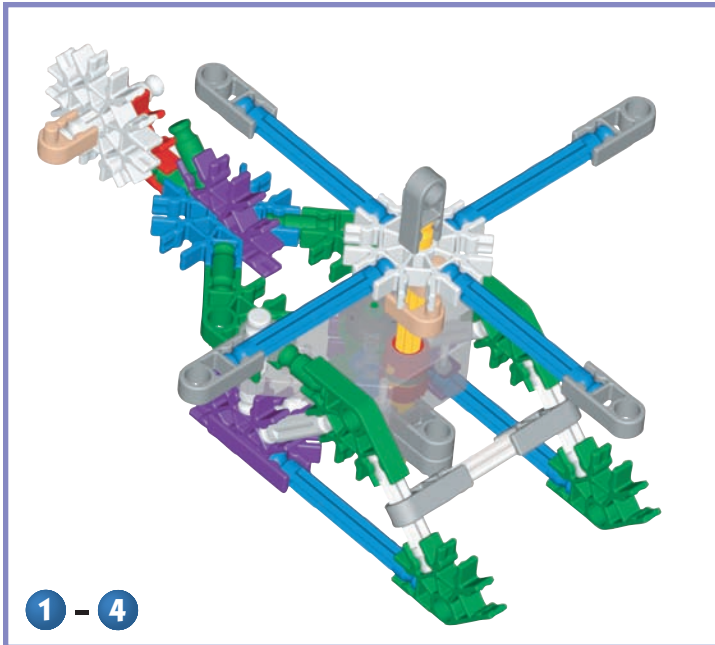
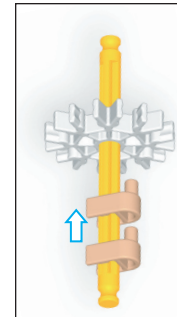
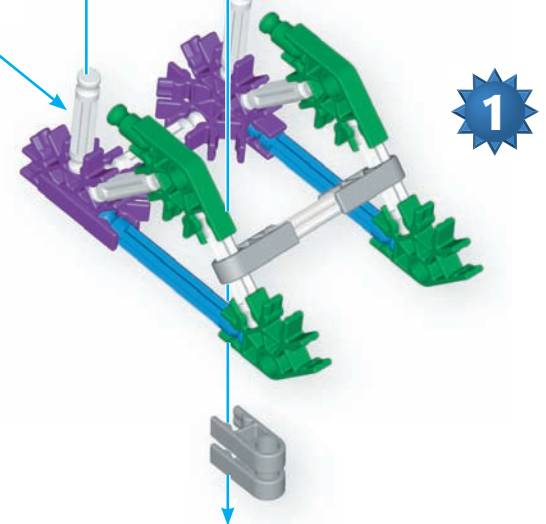
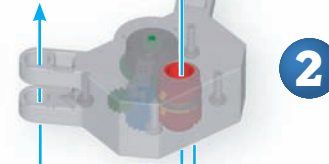
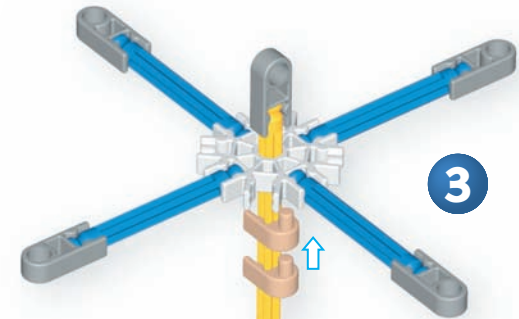

# Rocketships

In order to produce enough power to escape the Earth's gravity, rockets are made in separate parts called stages. These stages make the rocket more efficient and easier to assemble. The first stage is the launch vehicle. It gives the rocket its first big push toward space which requires a lot of fuel. When its fuel is used up, the first stage has finished its job—it then separates and falls into the ocean.

Next, stage two is fired. Since stage one is gone, the ship is lighter and can move faster. It also has

less gravity to fight because it is farther away from Earth. This allows the rocket to pick up more speed. At the time that the rocket reaches its altitude goal and the fuel in stage two is used up, that stage drops off and stage three takes over.

Because each stage drops away when it is finished, the vehicle never carries useless weight. Stage three is often the nose cone. It contains the Command Module where the astronauts live and the Service Module which is full of equipment.

- 7 
- 1 
- 8 
- 2 
- 2 
- 2 
- 6 
- 13 
- 6 
- 2 

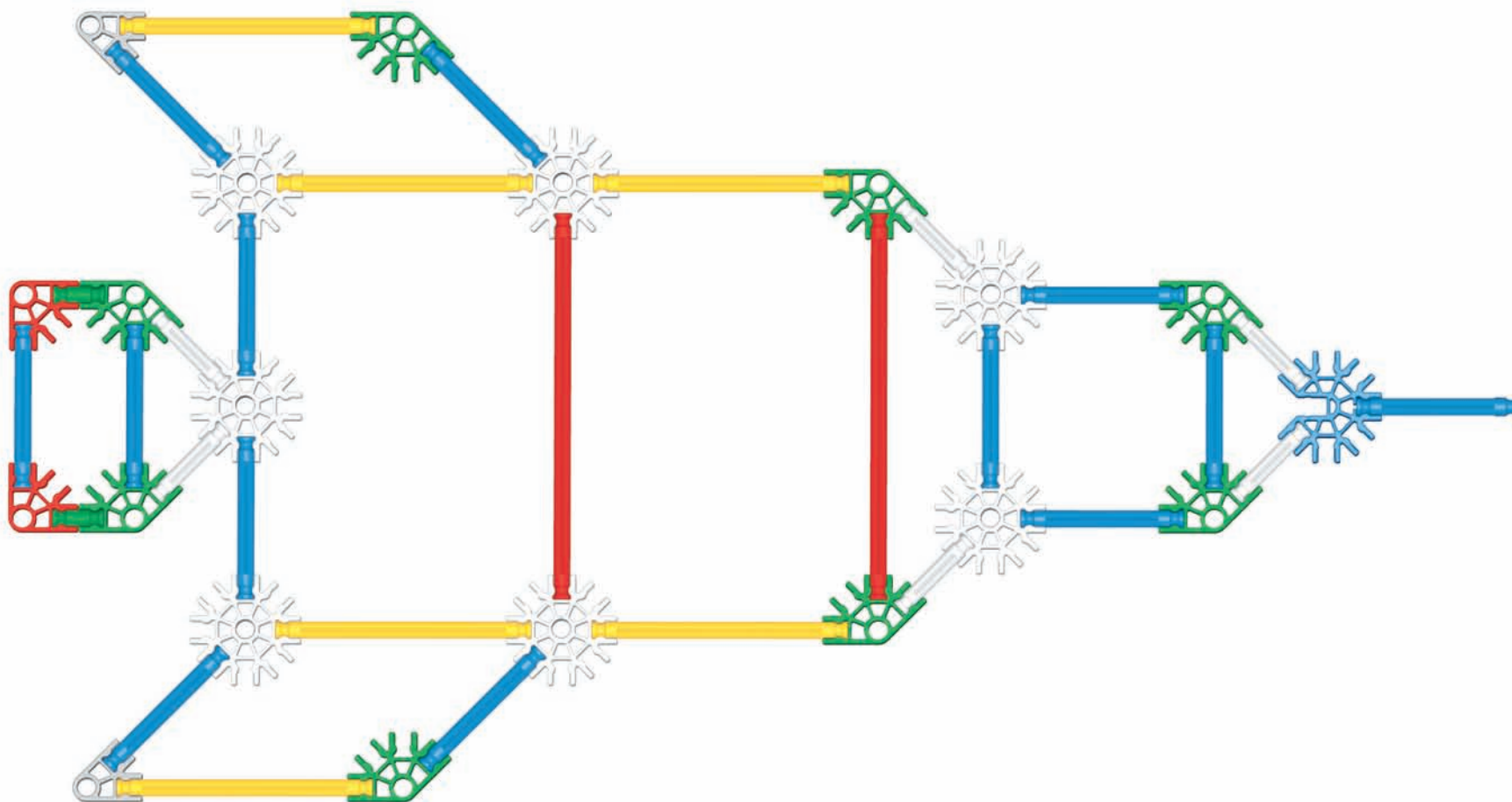

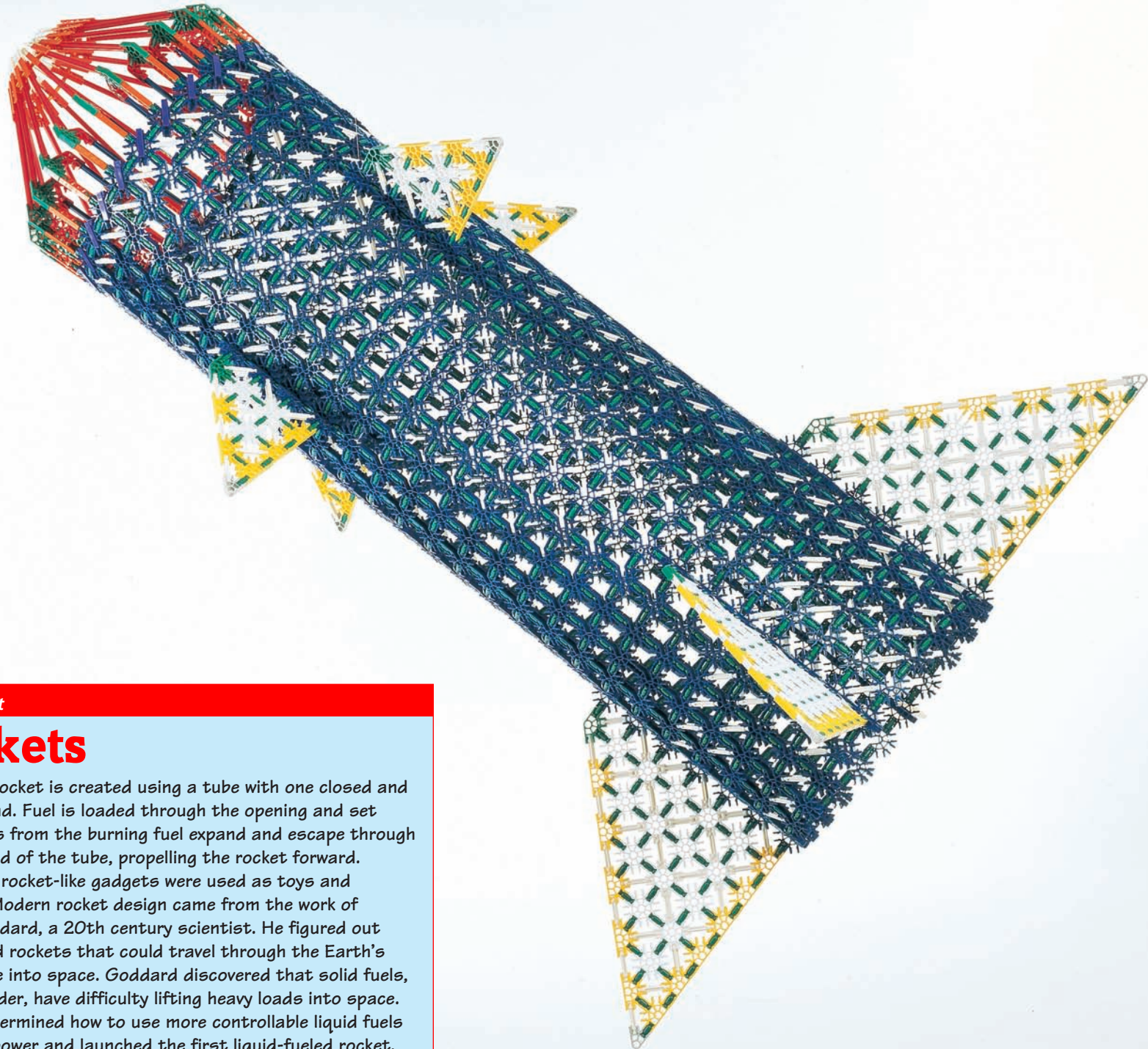

K'NEX<sub>print</sub>

## Rockets

A basic rocket is created using a tube with one closed and one open end. Fuel is loaded through the opening and set afire. Gases from the burning fuel expand and escape through the open end of the tube, propelling the rocket forward.

The first rocket-like gadgets were used as toys and fireworks. Modern rocket design came from the work of Robert Goddard, a 20th century scientist. He figured out how to build rockets that could travel through the Earth's atmosphere into space. Goddard discovered that solid fuels, like gunpowder, have difficulty lifting heavy loads into space. He also determined how to use more controllable liquid fuels for rocket power and launched the first liquid-fueled rocket.

# Mobile Launch Pads

Rockets can lift off a steel transporter called a mobile launch pad. With the rocket on board, the transporter can be taller than a 30 story building! The gantry, the frame that supports the rocket, has an elevator in it. The elevator takes the astronauts up to the rocket stage they travel in. The platform is as big as a baseball infield. The transporter moves very slowly, gently and carefully on tank-like treads (the K'NEX model uses wheels) so the rocket will not fall over.

4		1		8		26	
4		4		14		20	
19		2		2		14	
4		16		12		12	

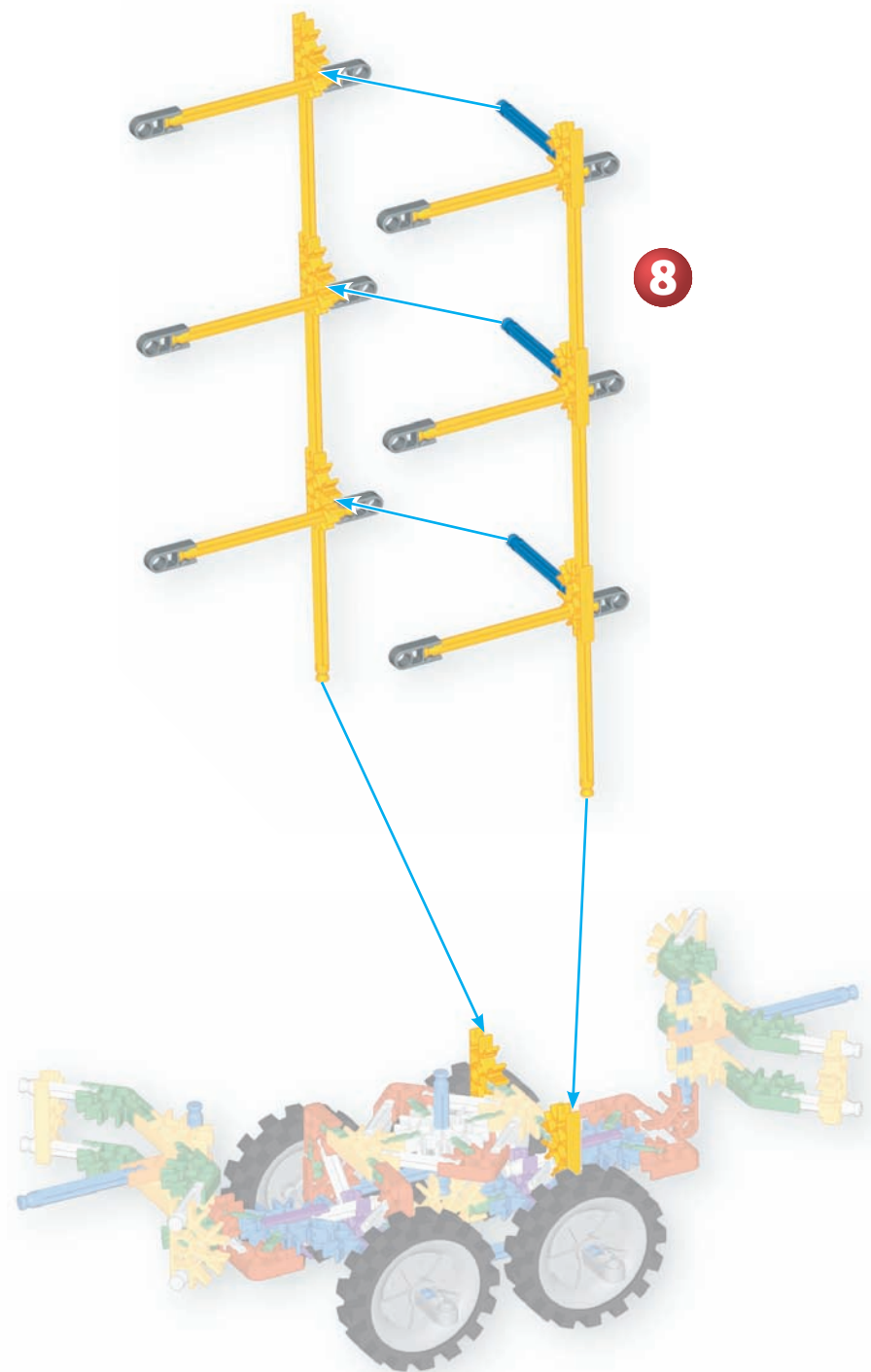
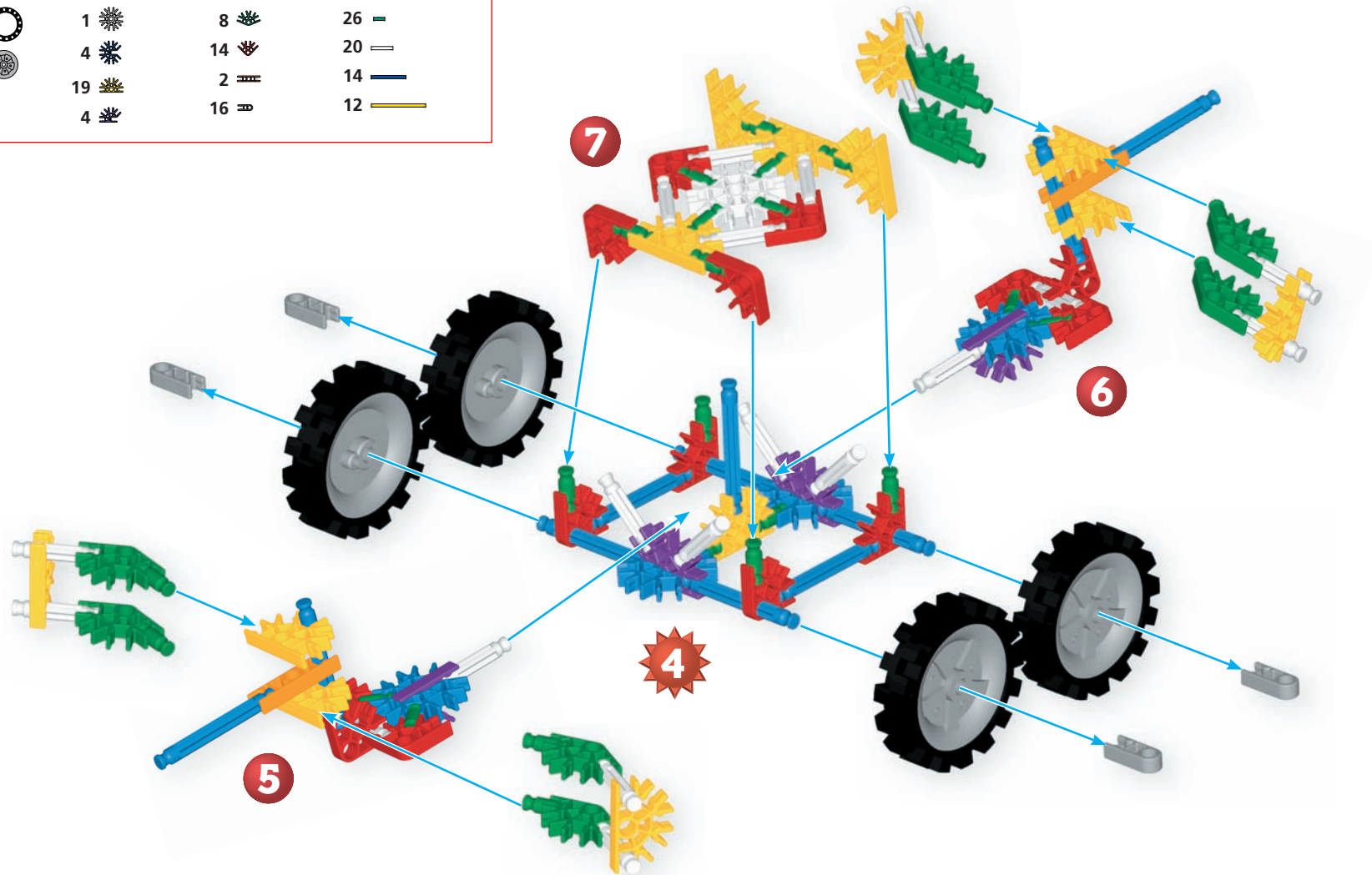

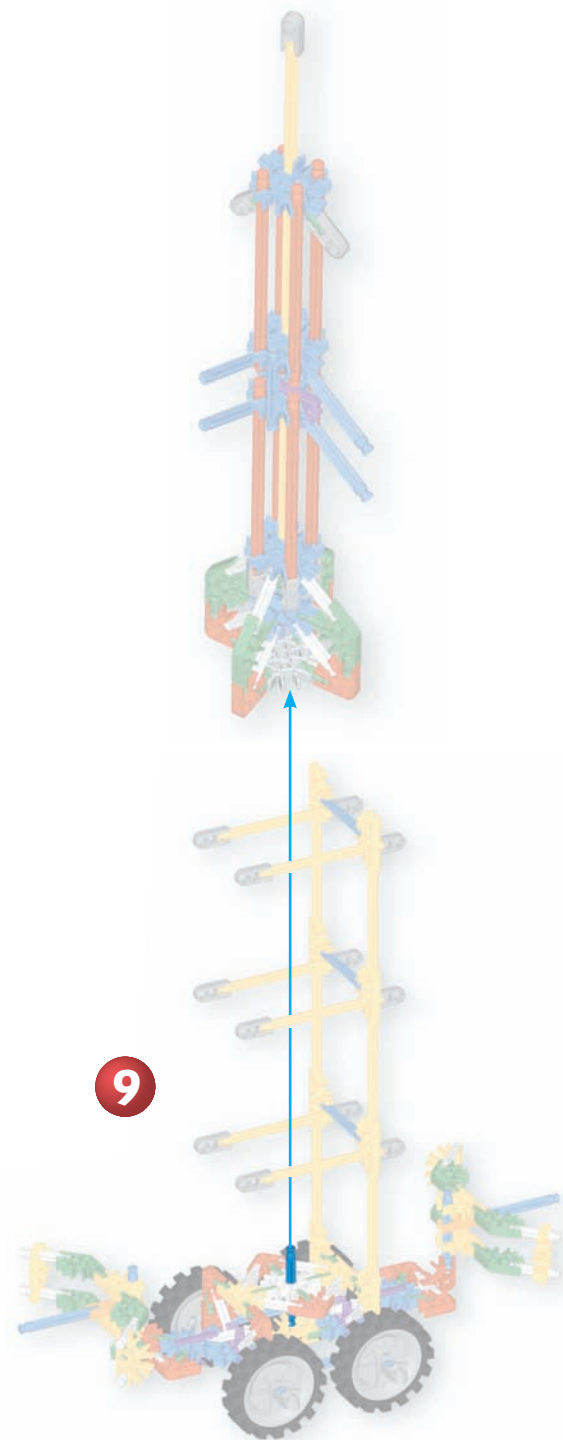

9



1 - 9



**K'NEXprint**  
**Rockets**

If you blow up a balloon and let it go, the air rushes backward out of the neck and pushes the balloon forward; rockets work the same way. To escape the strength of Earth's gravity an object has to travel away from the Earth at 25,000 mph (40,000 km/h). The greatest push comes at takeoff. When fuel burns in the rocket engine, gases are produced which rush backward out of the engine. This pushes or thrusts the rocket forward. Thrust can be measured in pounds; some rockets have a thrust of millions of pounds.

Between 1968 and 1972, giant Saturn V rockets carried the American Apollo manned missions toward the Moon. Saturn rockets flew 13 times including ten manned missions. Big traditional rockets can be used only once. Either the main stage (payload) stays in space to do its work or, if it reenters the Earth's atmosphere, its outside is so badly burned that the capsule can never be used again. The other stages are lost in space forever, and some actually burn up in the atmosphere.

1 	4 	15 	3 
9 	4 	8 	8 
1 	7 	6 	

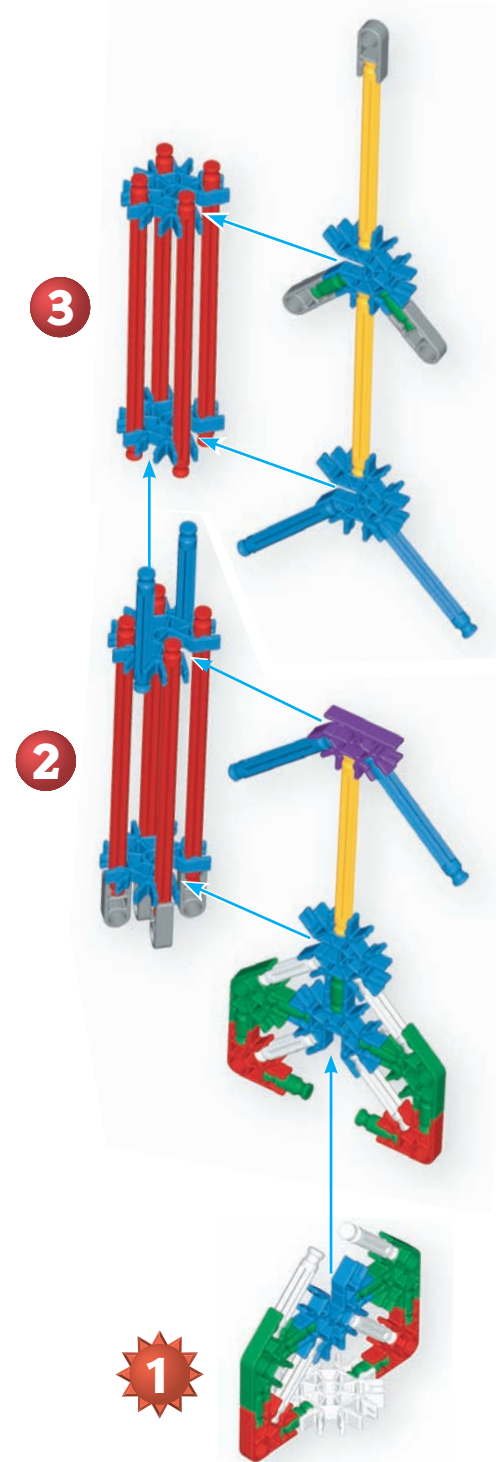

3

2

1

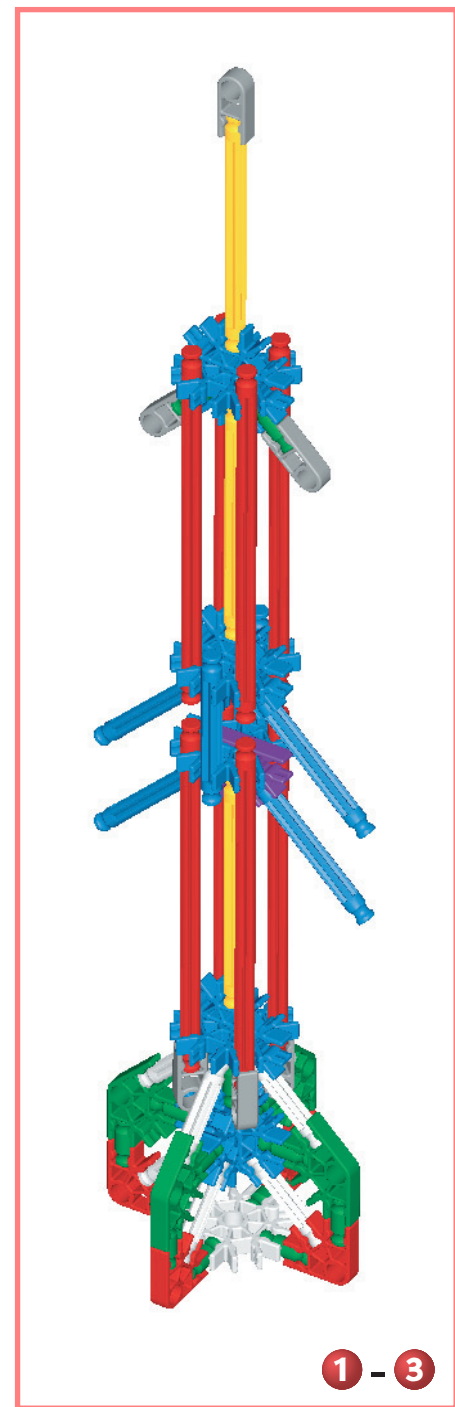

1 - 3

# Sailboats

Sailboats travel through the water as the wind blows against the sails, filling them with air. The first sailboats sailed in front of the wind and a little to either side. Strong winds and winds blowing across the sail created a loss of control. Since the sails on these primitive sailboats were not moveable, they were lowered in strong winds to avoid these dangerous circumstances.

Once they discovered how to create moveable sails to capture the wind from almost any direction, crews determined that tacking, or taking a zig zag course against the wind, was the only means of traveling by sail and wind.

Two different types of triangular sails, the settee and the lateen, allow more freedom and flexibility of movement than other sails.

Sailing has its own language. Running is sailing with the wind; reaching is sailing across it. Jibing occurs when you move the sail to capture the wind behind the boat. The parts of the sailboat which help keep relatively flat-bottomed boats from being blown sideways are the keel, dagger board, leeboard and centerboard.

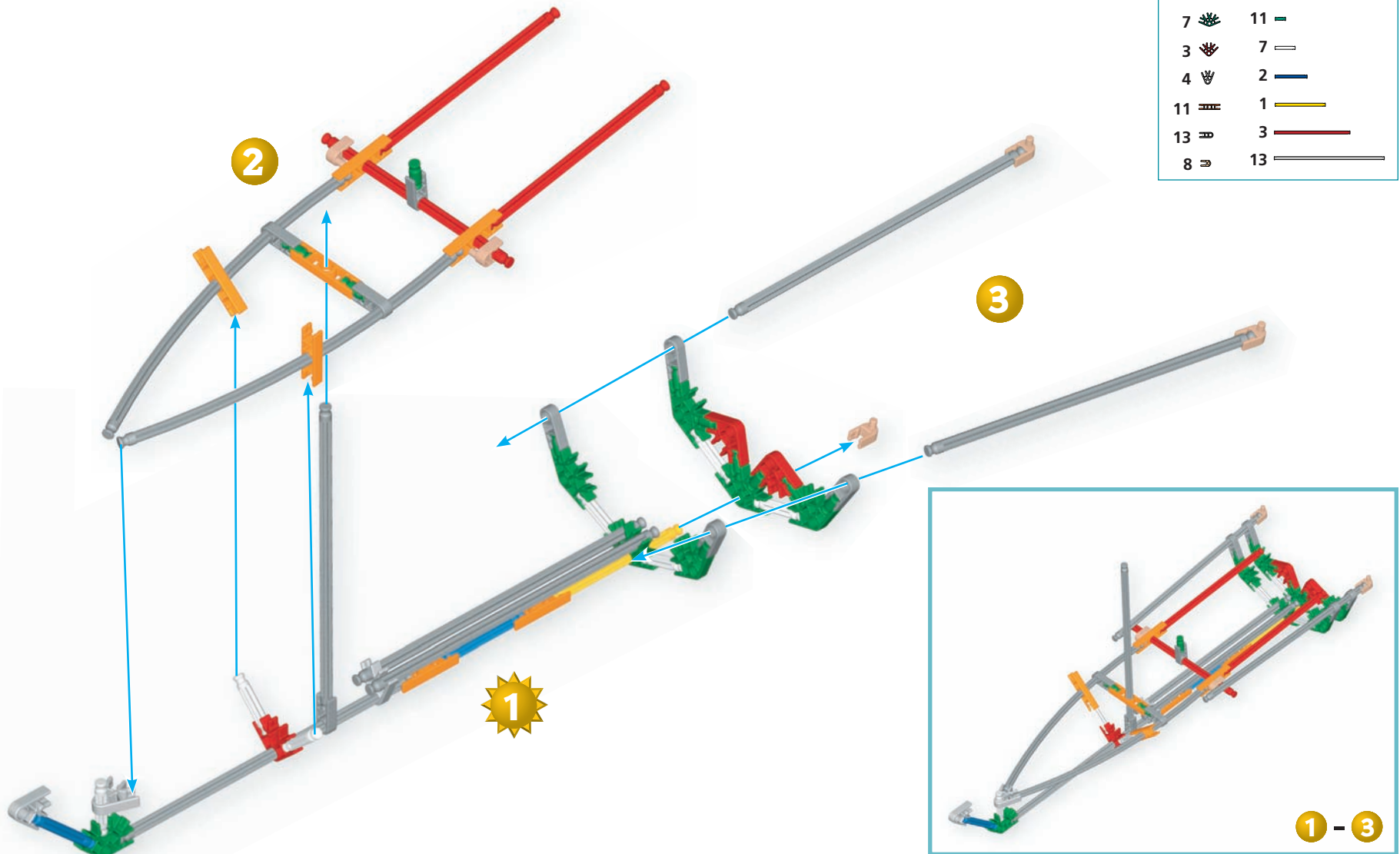

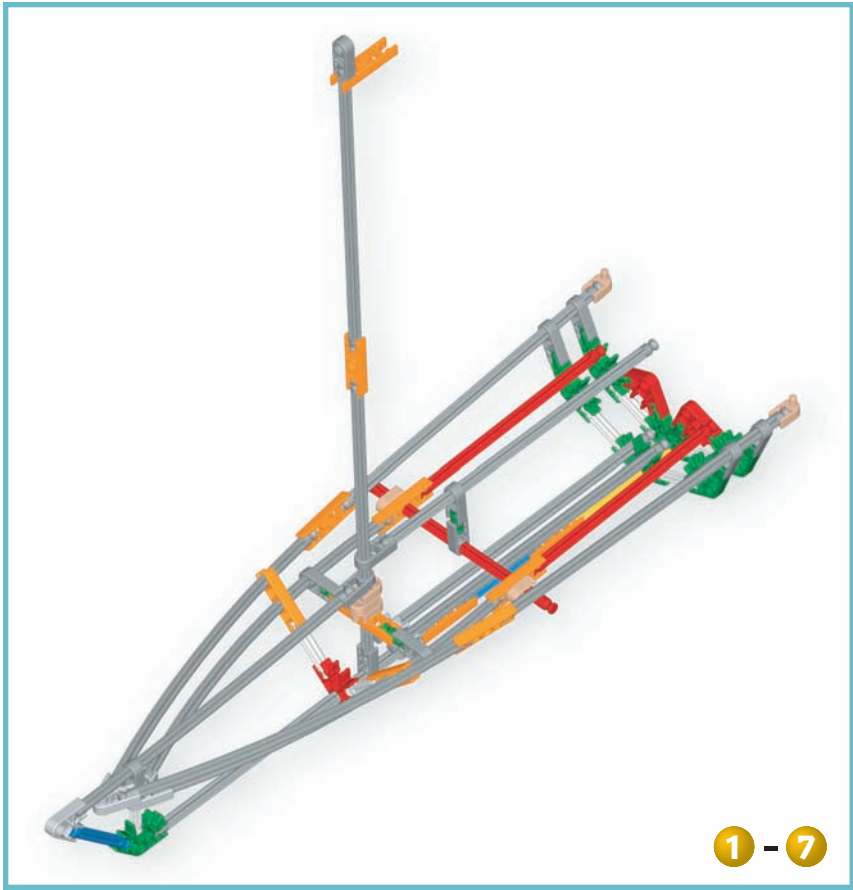
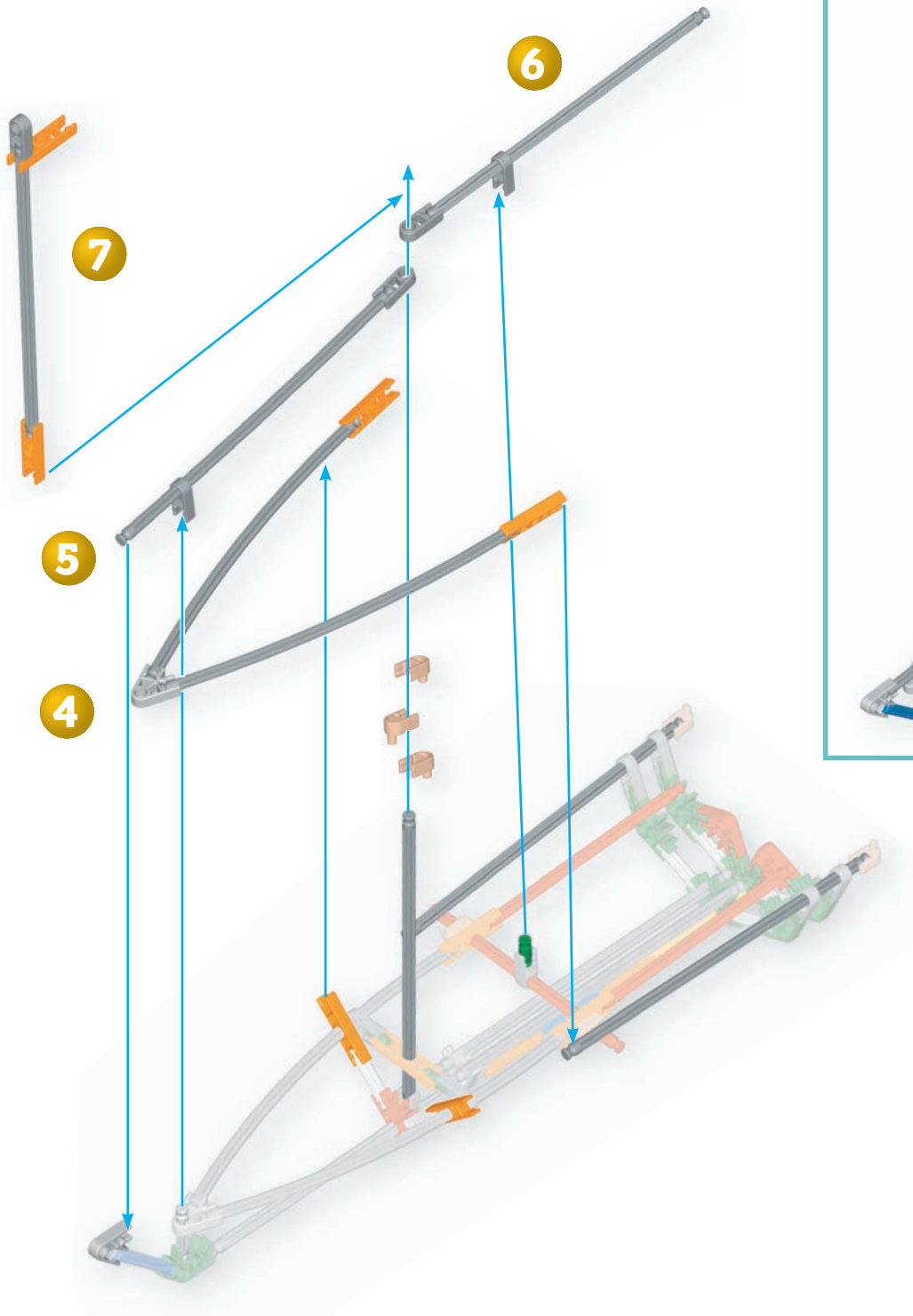

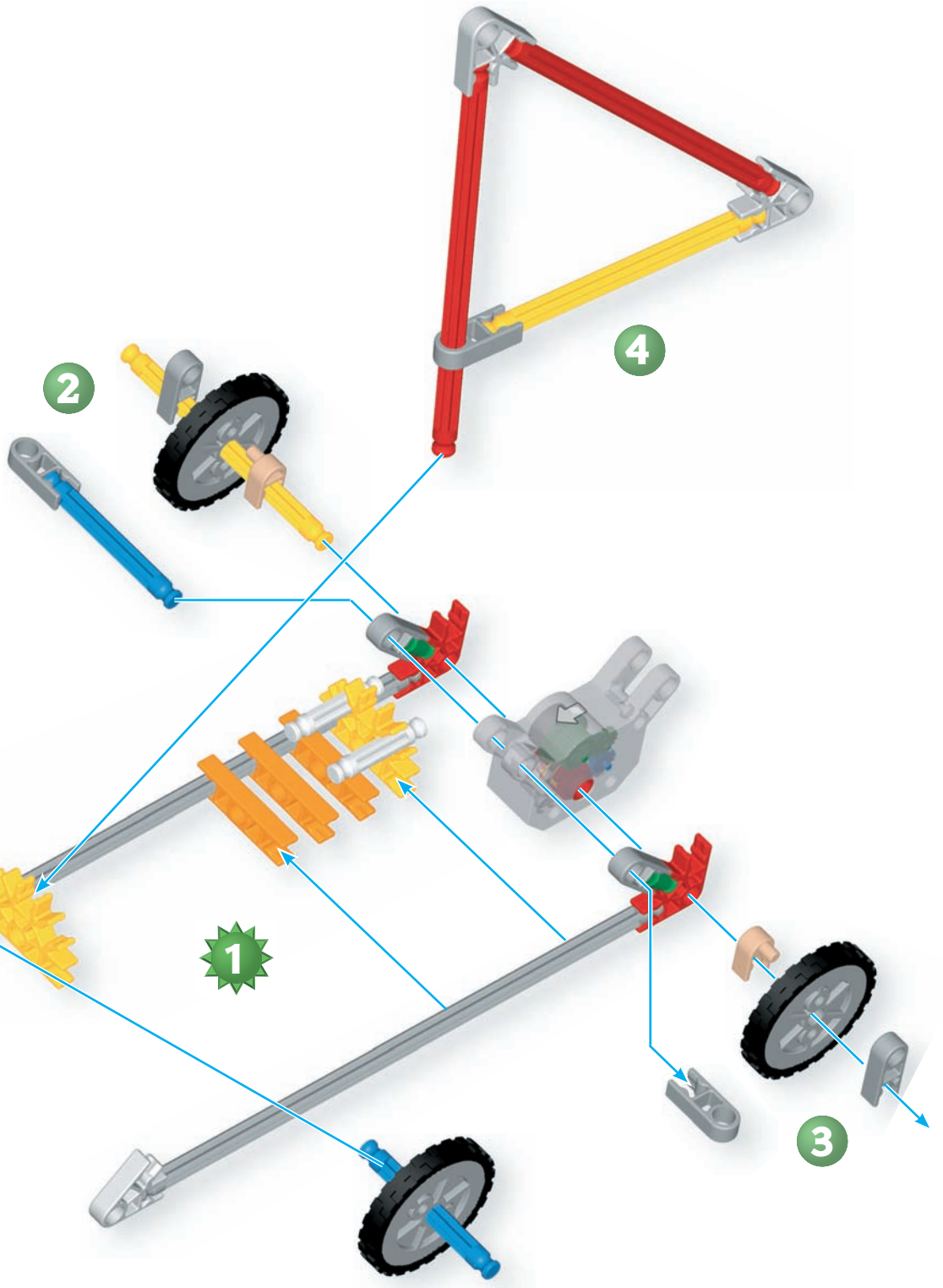
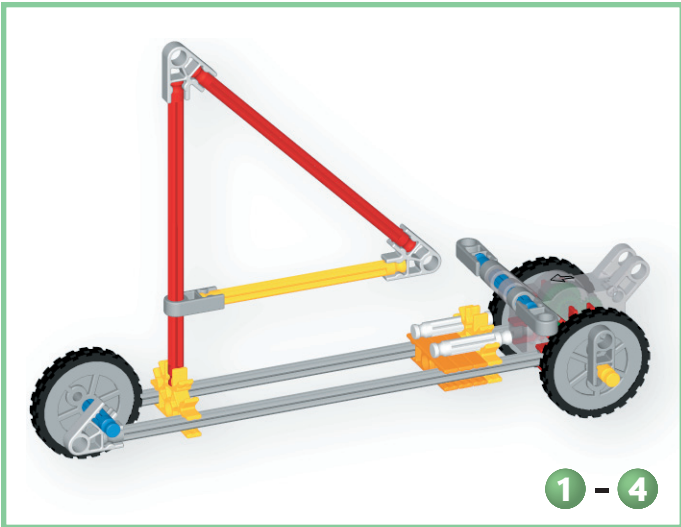

K'NEXprint

# Sand Racers

The sand racer combines the large tires of the dune buggy, used on beaches for recreation and patrol, and the sail of the windsurfer, used by surfers who want more control over the ocean waves, to create a unique and fun beach vehicle.

The sand racer has a sail that propels it along the sandy beach. The sail rotates to keep in front of the wind and the driver must be skillful at turning the sail without getting in its path. The closer the sail is to being parallel to the direction of the wind, the less effect the wind has on the motion of the sand racer. The large rubber tires use low air pressure so they ride atop the sand, rather than digging in, and allow great performance over beach terrain.

3	4	2	1
3	3	2	
2	7	2	
2	2	2	
2	2	2	

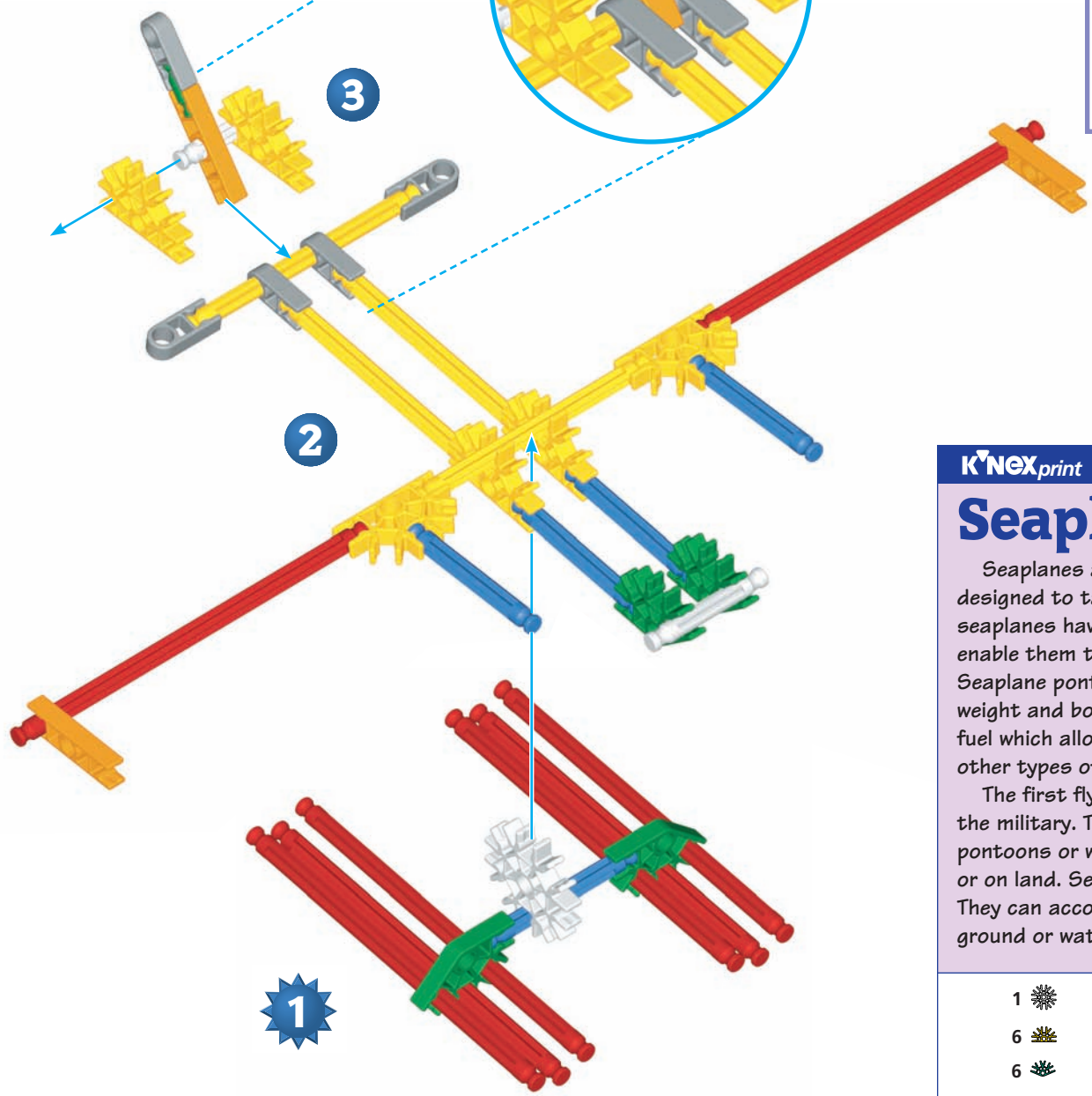
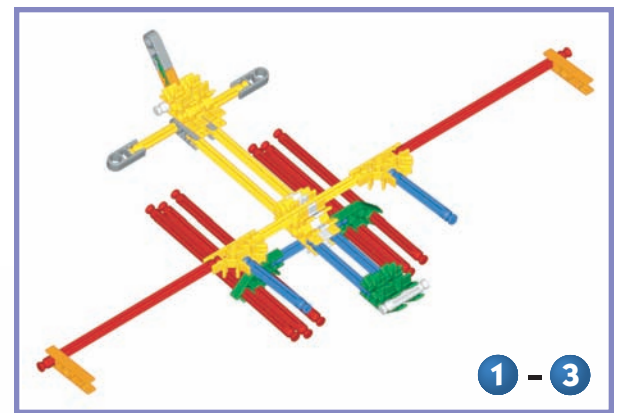
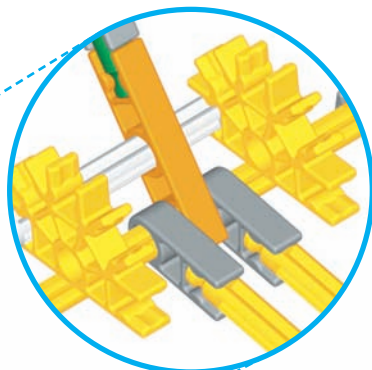
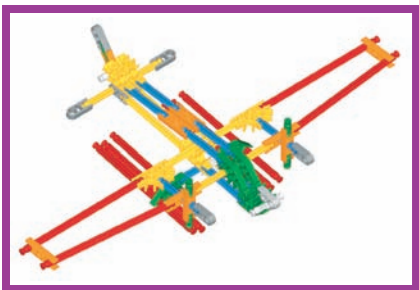

**K'NEXprint**

# Seaplanes

Seaplanes are a specific type of propeller (prop) plane designed to take off and land in water. Unlike other planes, seaplanes have legs with floating "feet" (pontoons) that enable them to perform rescues and do other work on water. Seaplane pontoons are often made of wood because of its weight and bouyancy. These pontoons carry large quantities of fuel which allow these planes to fly longer distances than some other types of prop planes.

The first flying boats (mostly biplanes) were designed for the military. They were usually equipped with interchangeable pontoons or wheels so that they could travel in the air, water or on land. Seaplanes travel and maneuver well at low speeds. They can accomplish tasks more easily and quickly than either ground or water vehicles.

1	1	7	5
6	9	2	10
6	7	9	

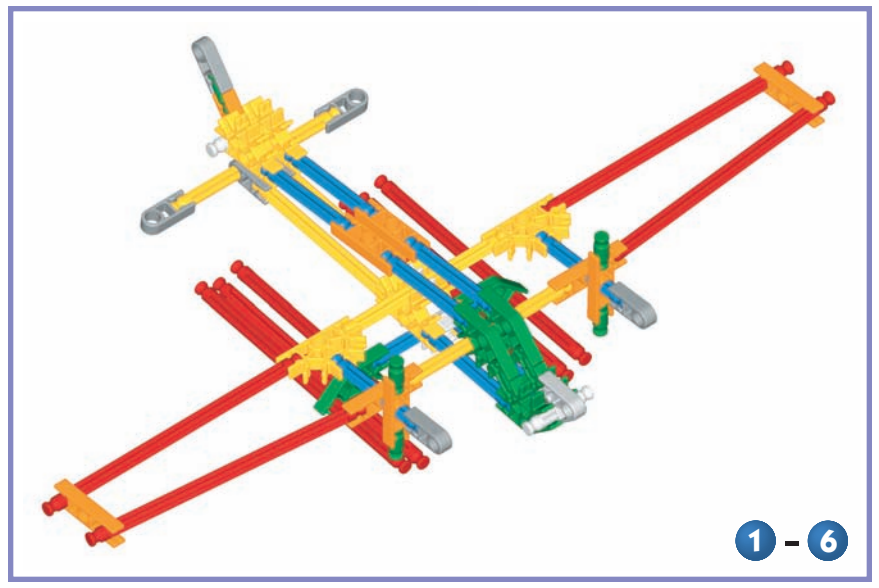
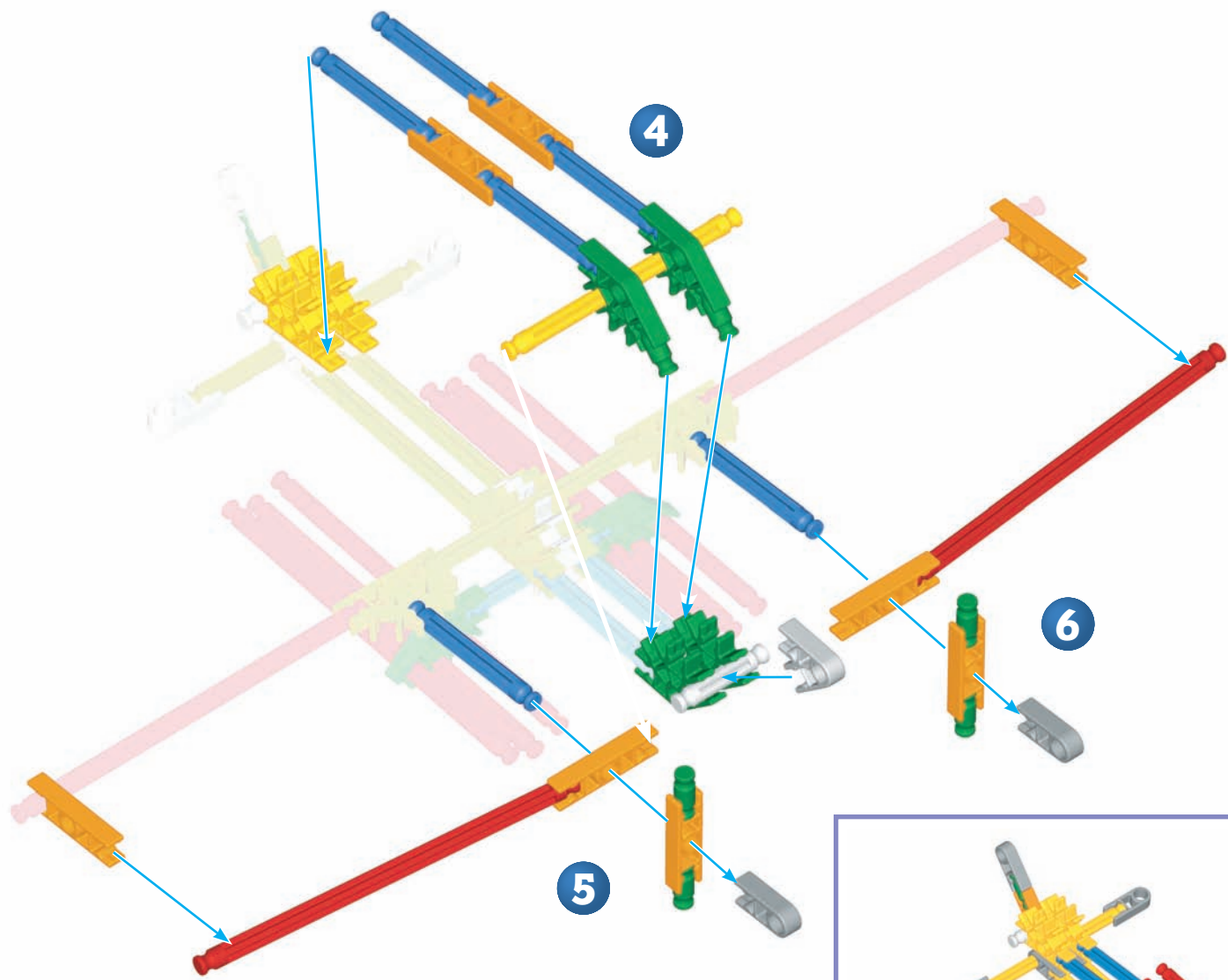

# Space Shuttles

The Space Shuttle usually travels on five to 30 day missions from Earth into space and back again. Large rockets help launch or push the shuttle outside the Earth's atmosphere. As each rocket's fuel runs out, it detaches and falls back to Earth. In orbit, the shuttle only uses its engines to change position or orbit path. After reentry into the Earth's atmosphere, it behaves like a huge glider with no engine.





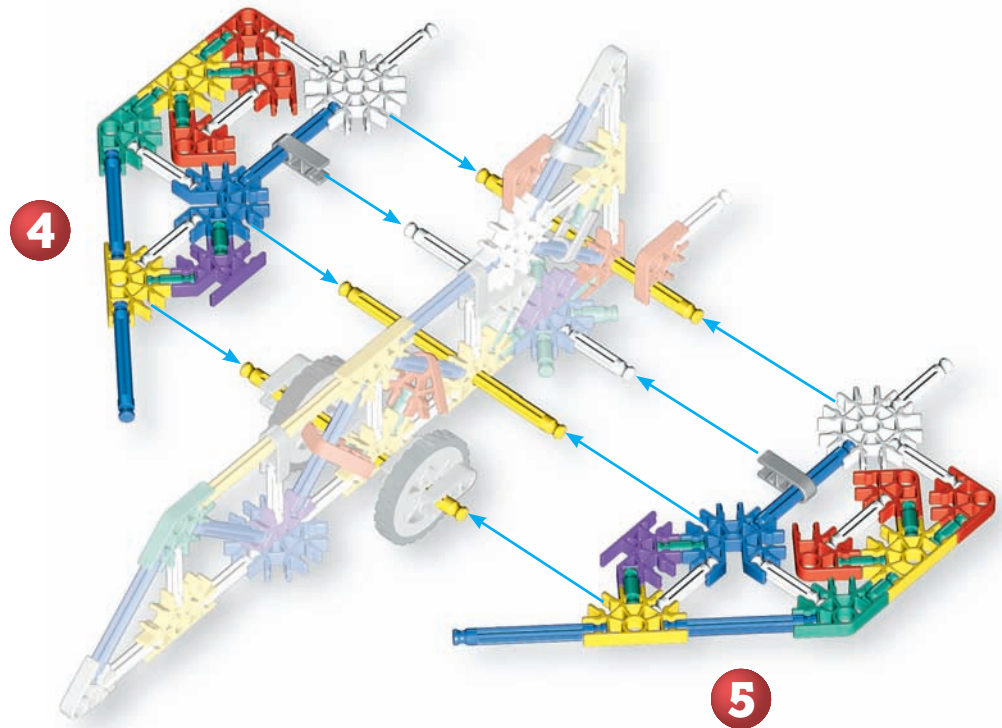
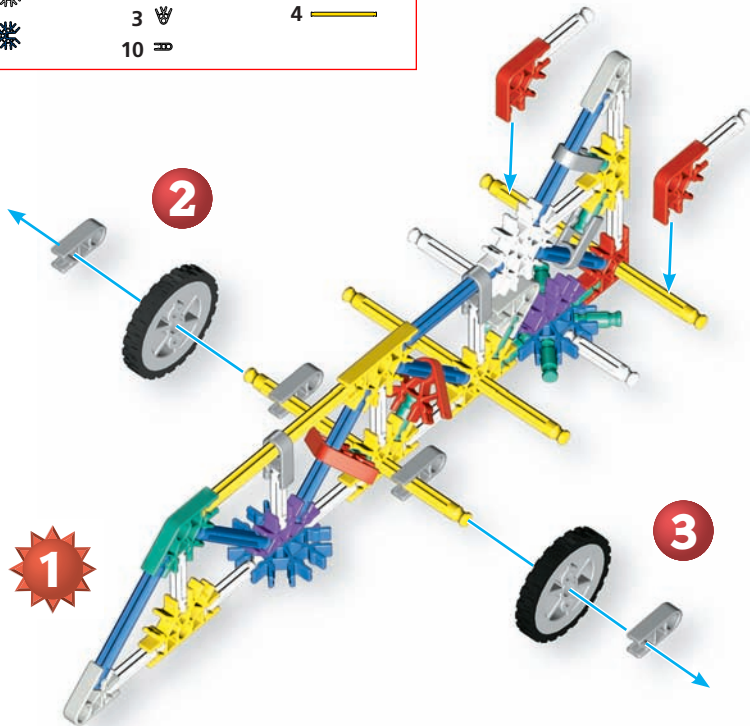





The shuttle crew (mission commander, pilot and mission/payload specialists) performs missions including launching satellites, repairing space equipment and/or conducting experiments. The shuttle has a flight deck (shuttle control center), living areas and payload or cargo bays. The shuttle is covered with glass or tile for protection from the intense heat faced during fast reentry into the Earth's atmosphere.

2		9		23	
2		4		25	
3		3		13	
4		11		4	
		3			
		10			



# Spaceplanes

In the 21st century, there will be hundreds of satellites in orbit around the Earth and at least one space station where people will live and work. New forms of transportation are constantly being developed to transport people and equipment to and from space. These new vehicles could take off and land like jet airplanes but would use highly advanced jet engines capable of lifting them through the Earth's atmosphere. Once beyond the atmosphere, the engines would convert to rocket power to propel the vehicle/transporter through space.

- |   |   |    |   |   |   |   |   |
|---|---|----|---|---|---|---|---|
| 2 |  | 11 |  | 3 |  | 2 |  |
| 2 |  | 6  |  | 8 |  | 2 |  |
|   |   | 8  |  | 6 |  |   |   |

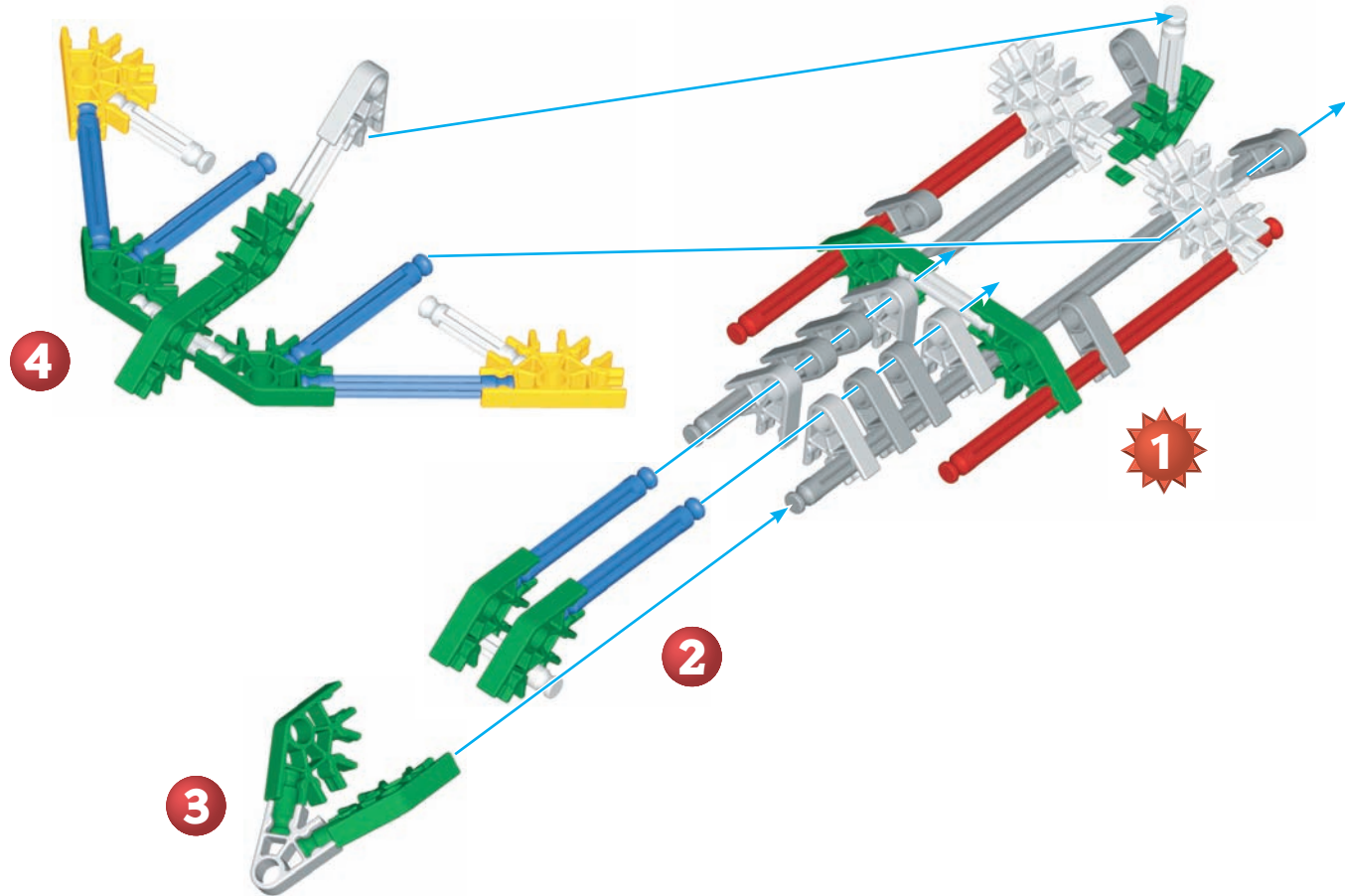
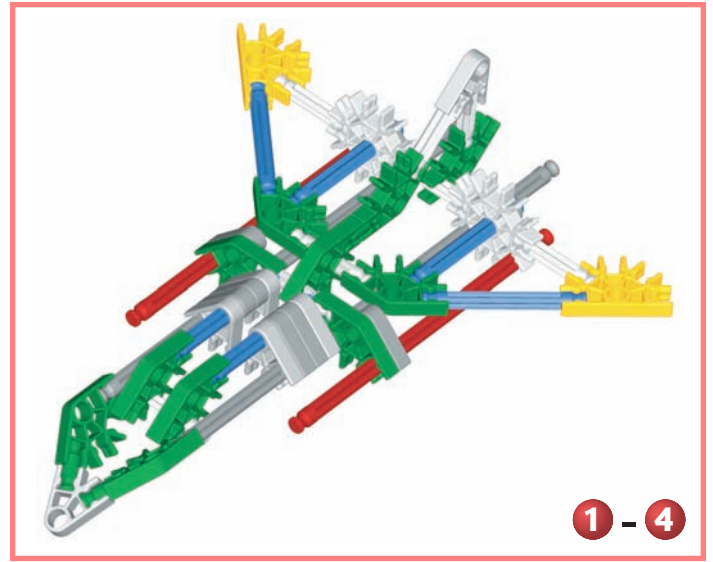

# Space Station

A space station is a large, manned satellite on which people can live for long periods of time while it orbits the Earth. Here astronauts prepare for space exploration and conduct scientific experiments. The crew monitors the space station and makes necessary repairs.

A new international Space Station, the largest to date, will begin being launched in 1997 and, after 70 launches, should be complete by the year 2002. The base station consists of modules linked together and powered by solar panels. Different countries from around the world will provide various space station components, making it a true international effort. It is expected that crews will work on the space station in shifts of 90-120 days, and that the large complex itself will stay in orbit for about 30 years.

The International Space Station pictured here was built from K'NEX by Michael Fruhwirth, an aerospace engineer working on the actual project with McDonnell Douglas. The model, made from 3,500 parts, is 1/25 the size of the Space Station and took more than 1500 hours to complete.

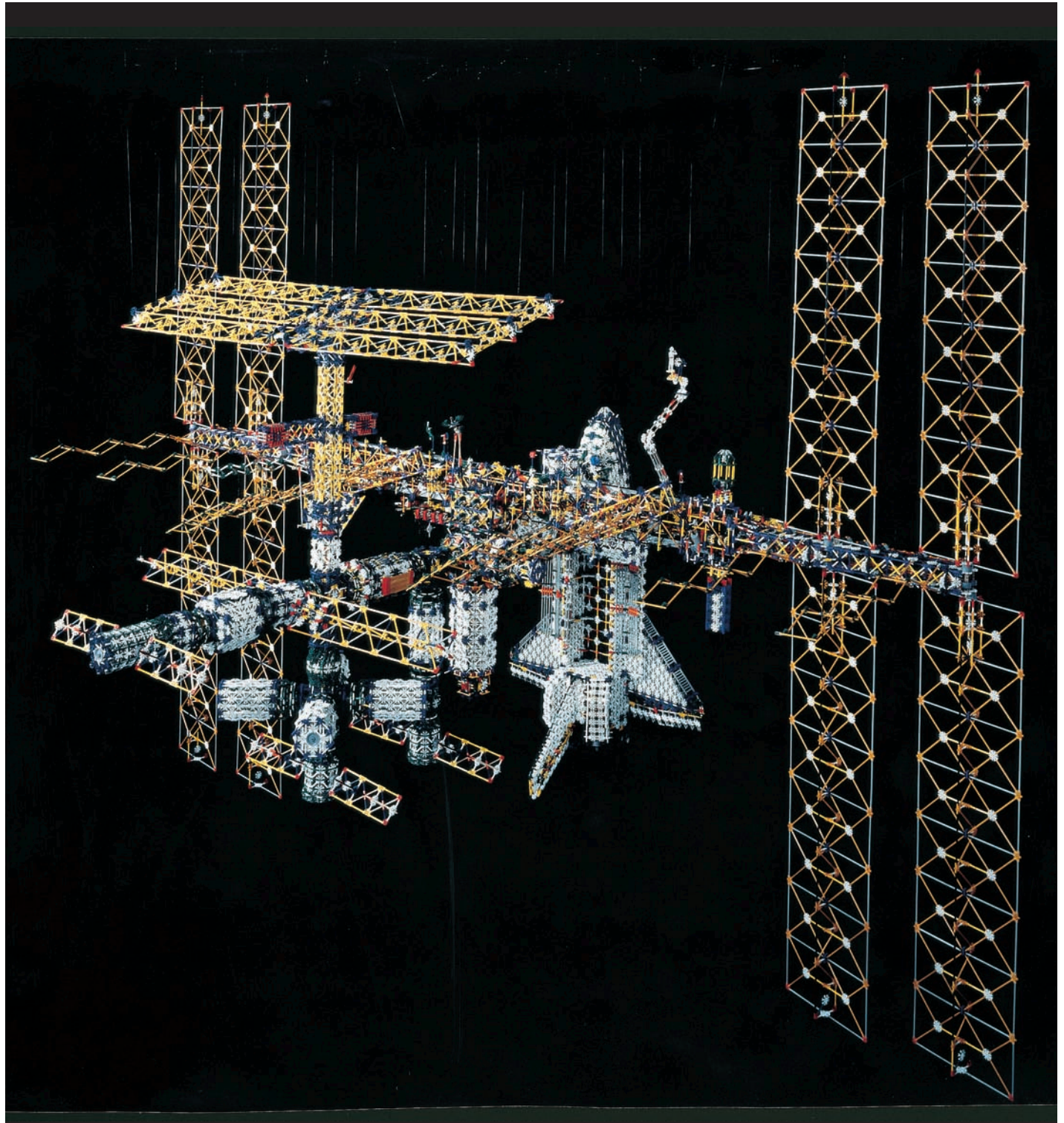

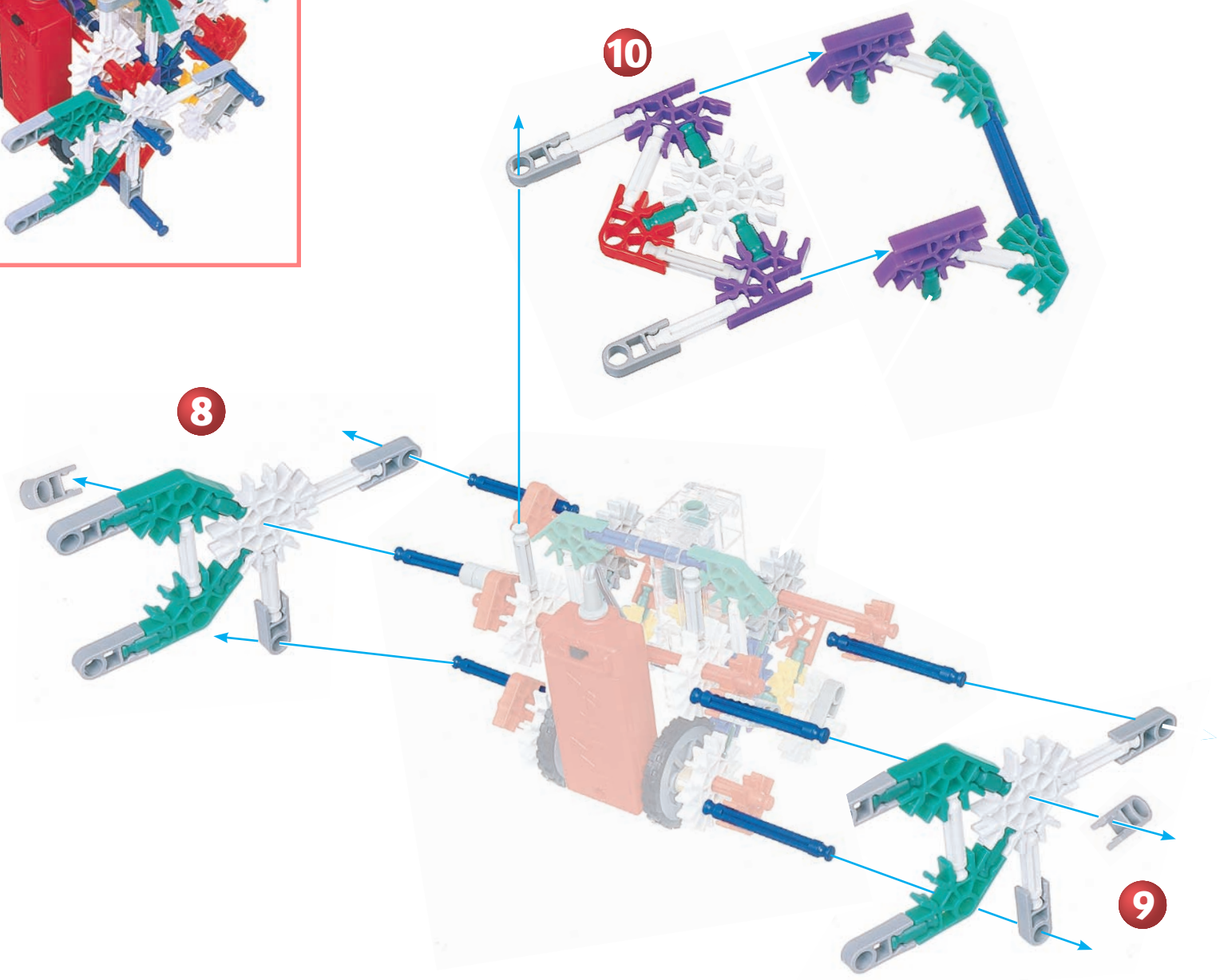
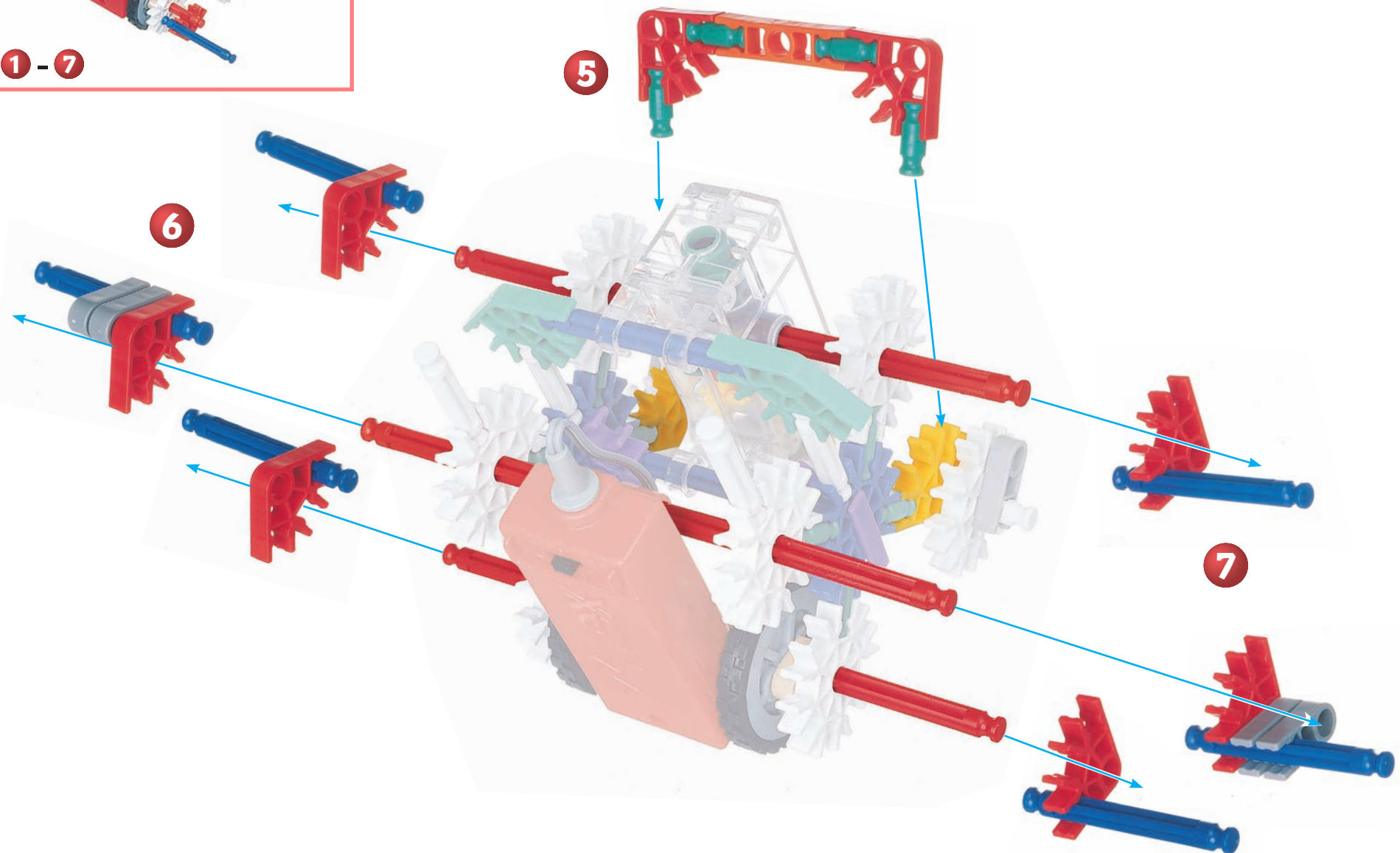
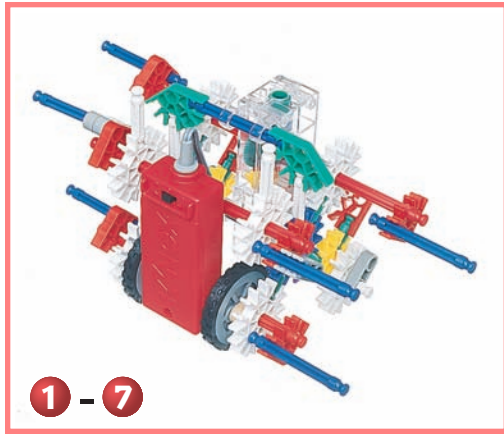

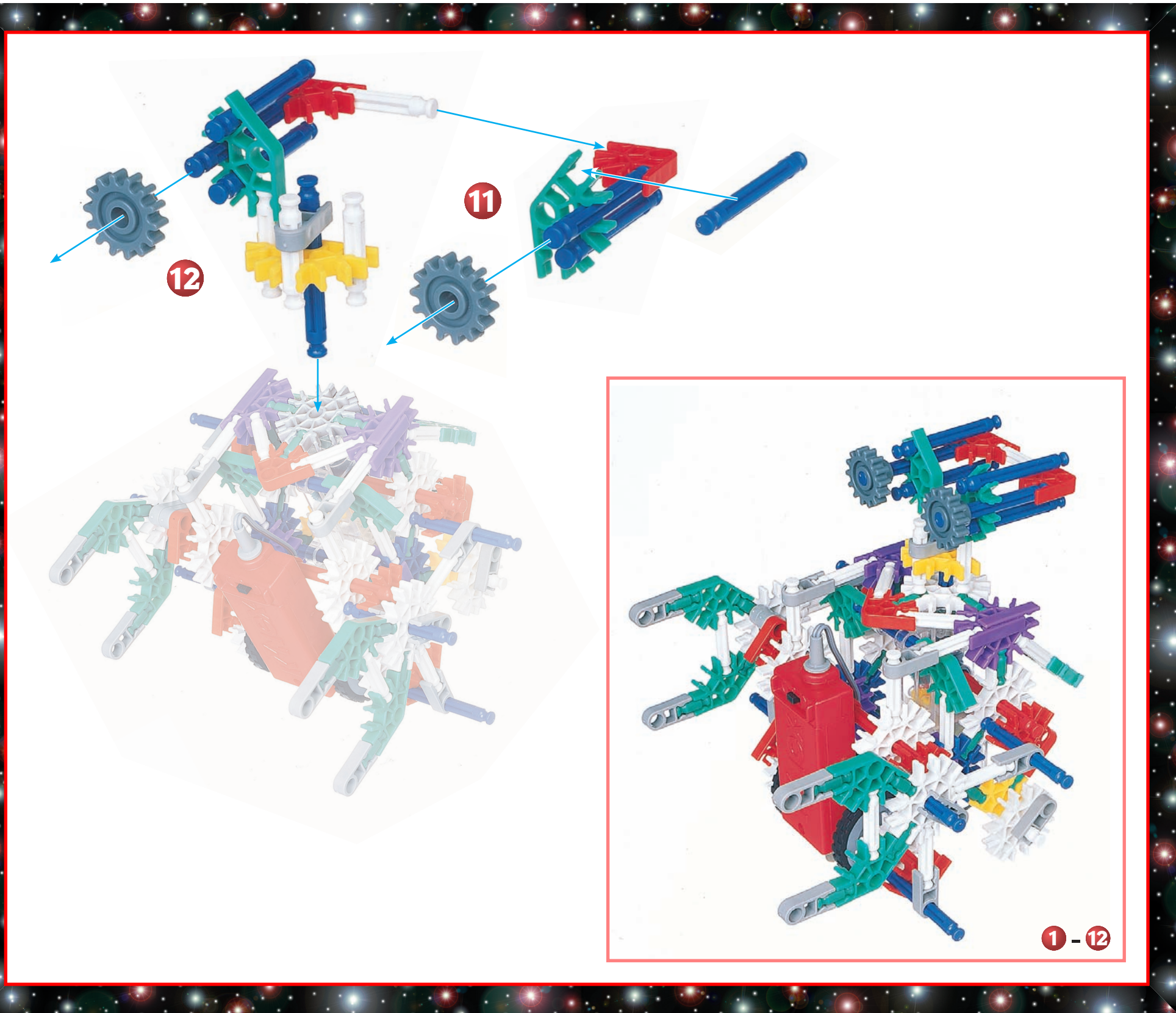

K'NEXprint

## Space Robots

The rapid development of space age technology has allowed humans to find out more about other planets in the solar system by traveling into space and bringing back all kinds of photographs, samples and information. Scientists created robot probes to accomplish this, since it is too dangerous and expensive to send humans.

The Viking probe was designed to explore Mars and find a suitable landing site. Information sent back to scientists made this possible, and the Viking landed itself. Using onboard computer control, the probe collected and tested soil to determine what it was made of and to see if it supported life. It also ran tests to see if humans could survive there.

Goals for continued robot-dependent space exploration include a voyage to and exploration of a star, more research of other planets and robots which do not depend on remote control.

1	6	25
2	10	22
2	11	16
11	2	3
2	1	
3	19	
	2	

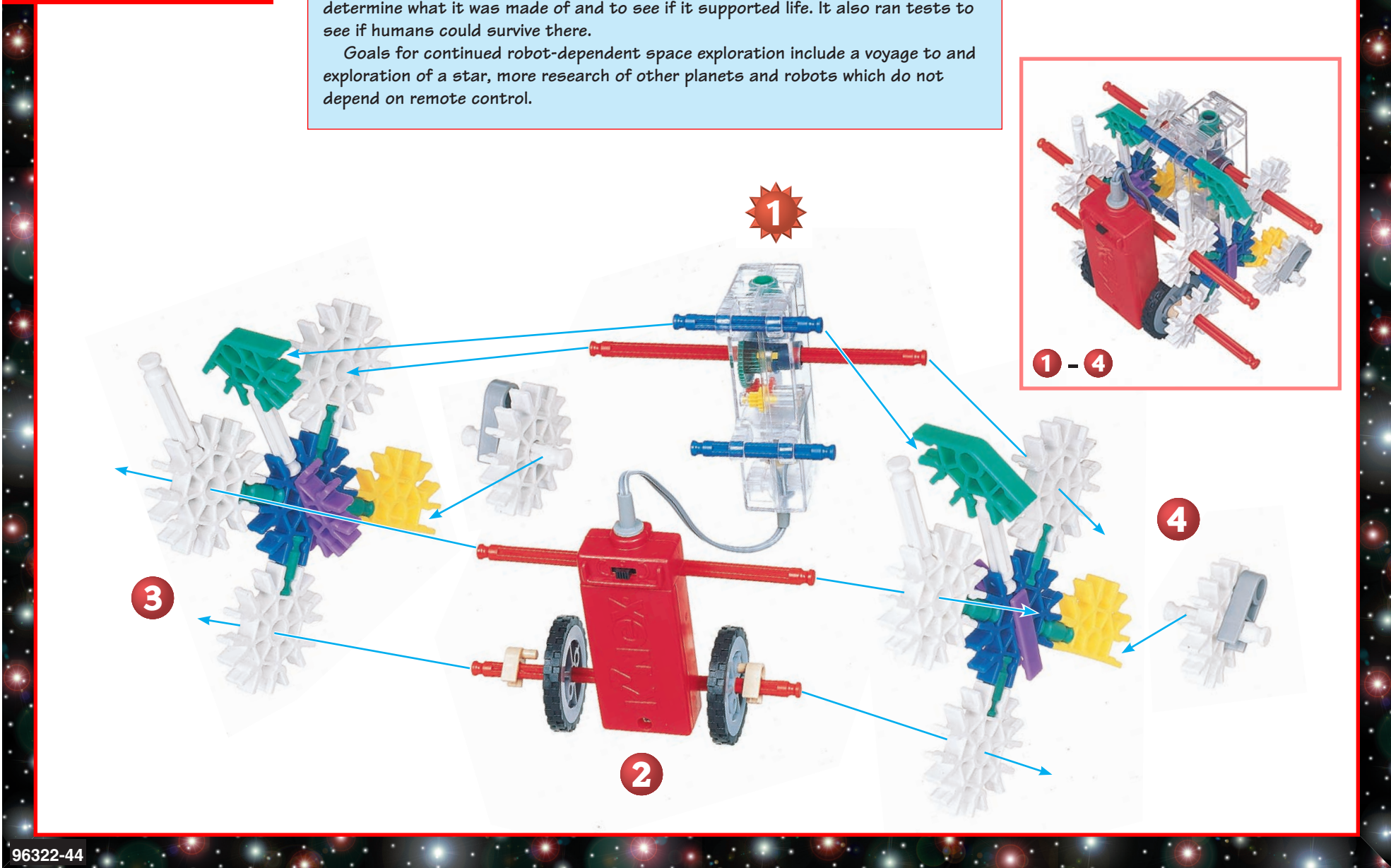

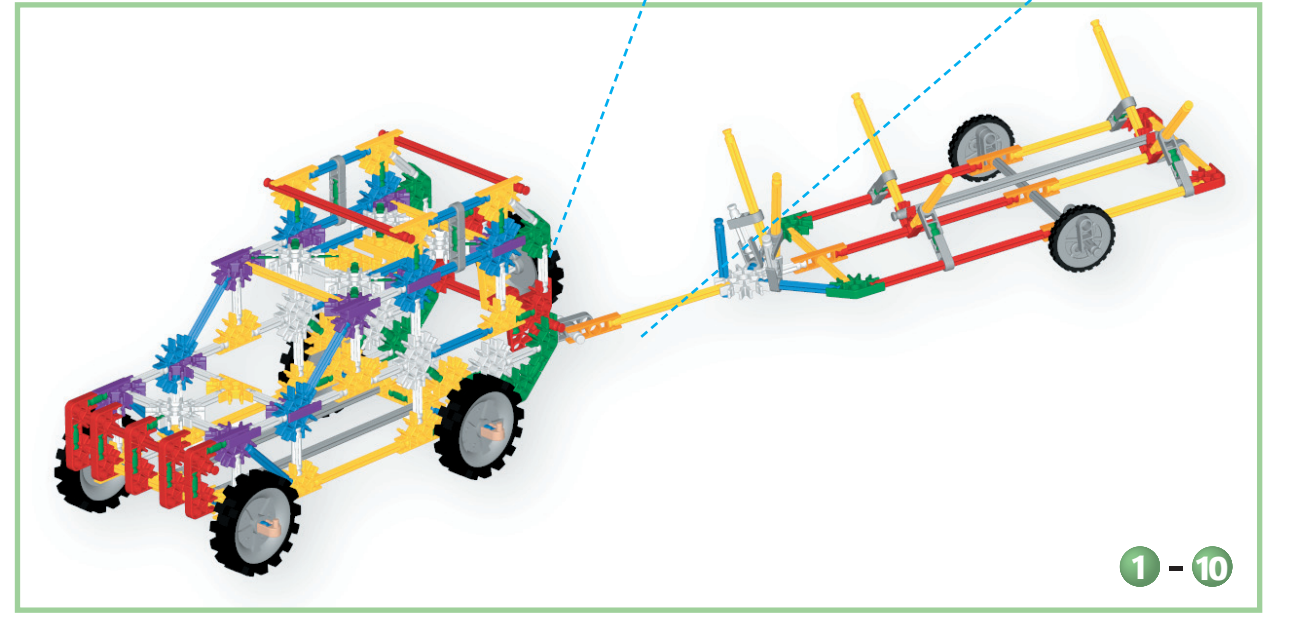
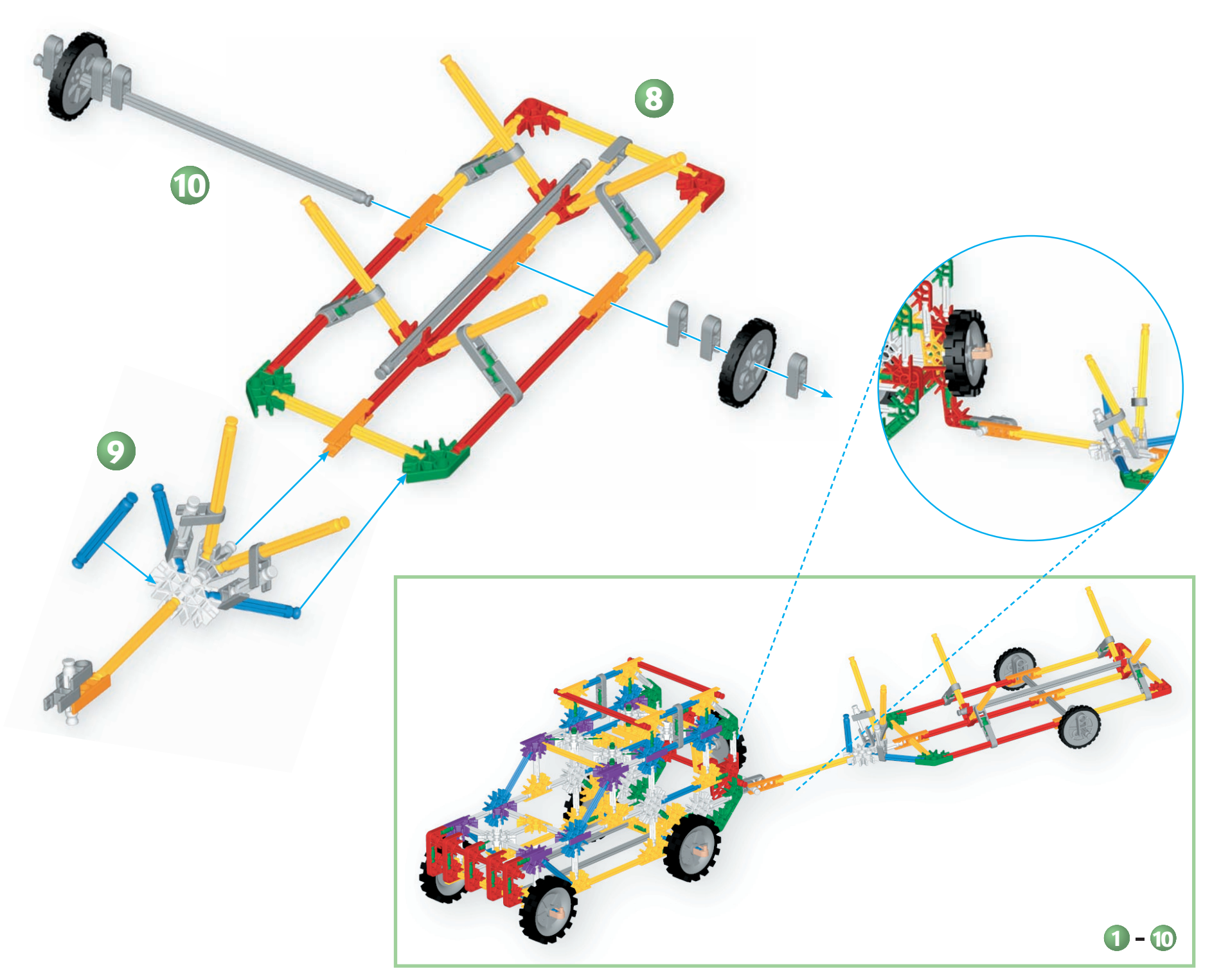
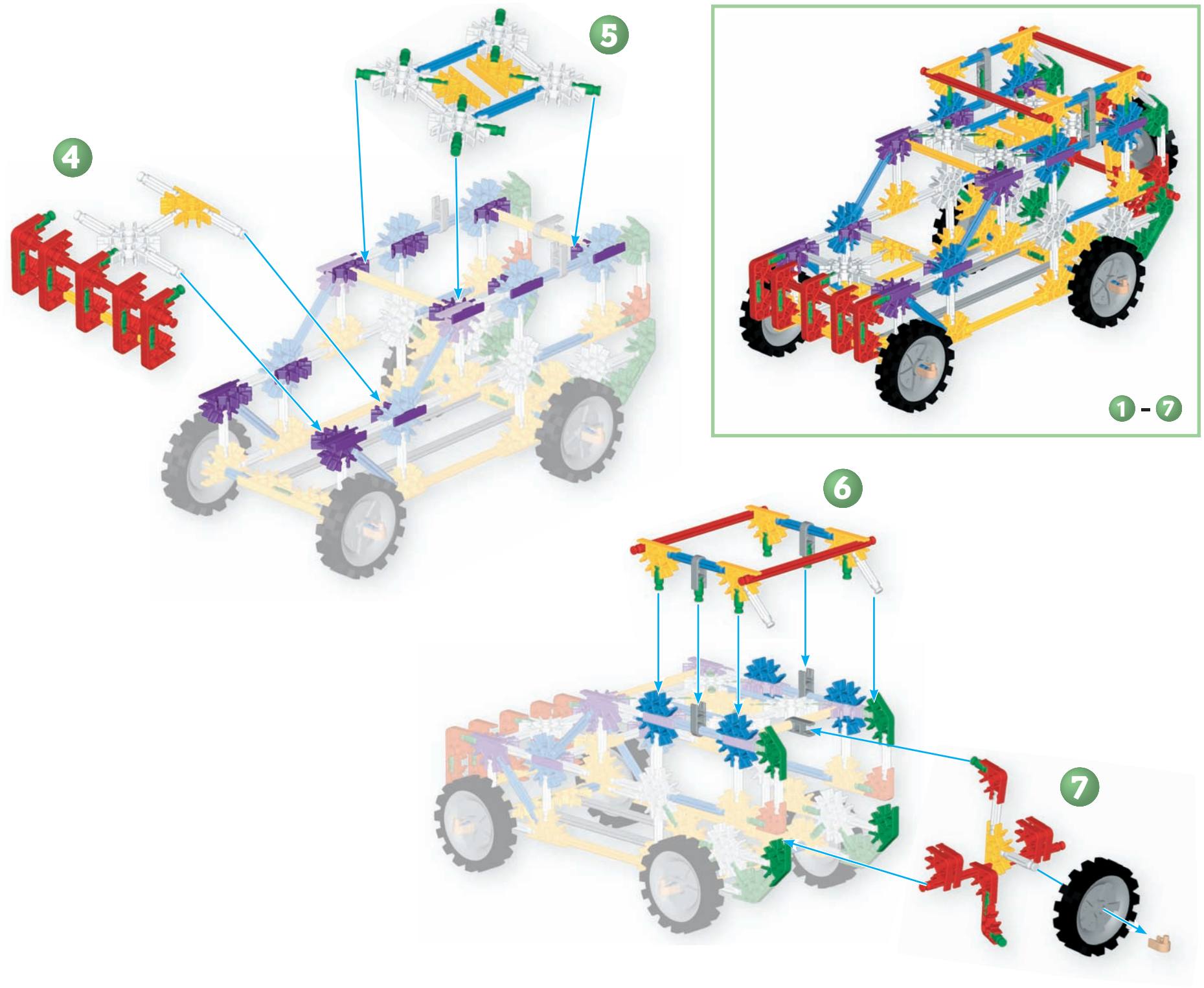

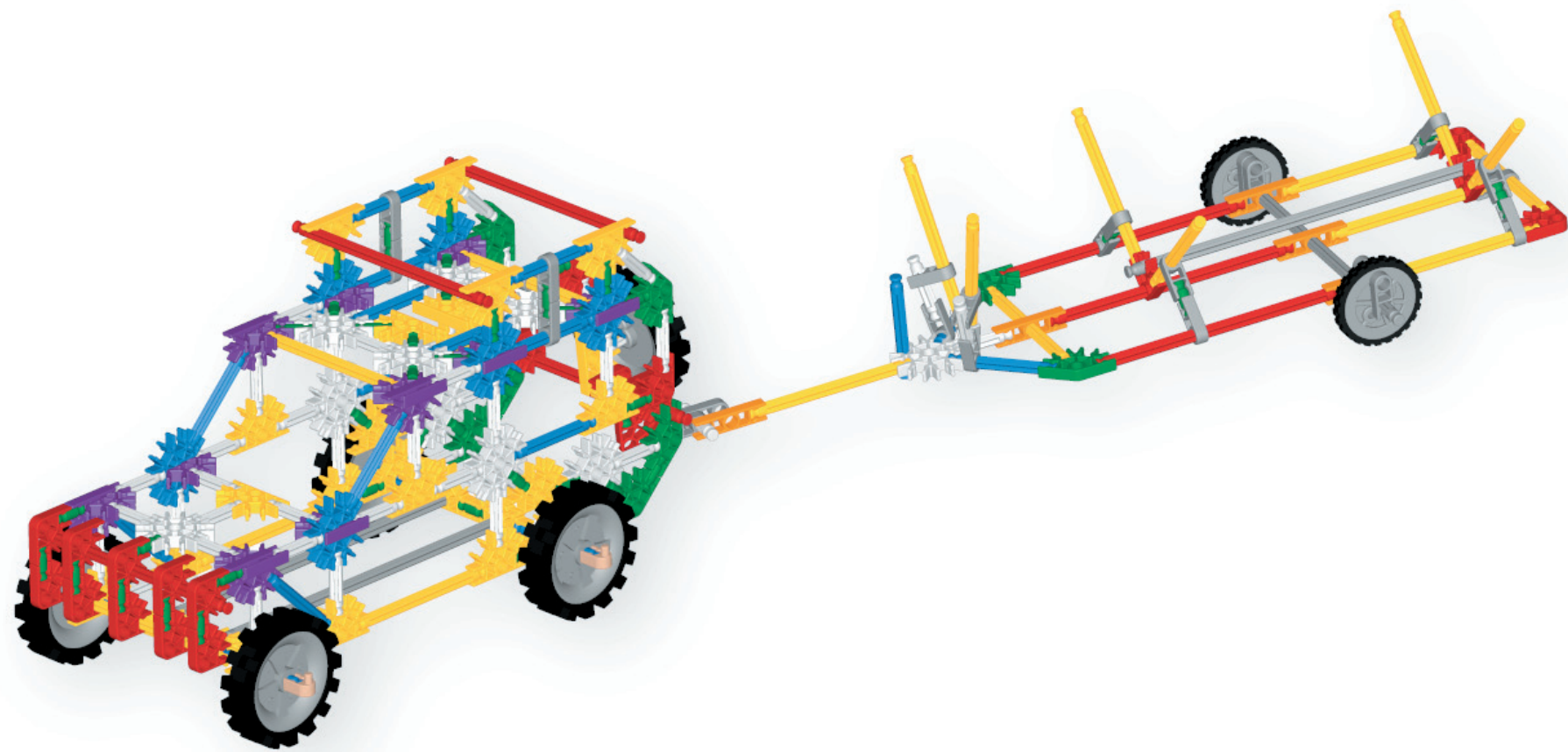

5		26		49	
2		14		43	
5		8		19	
2		23		17	
10		1		7	
6		5		4	

**K'NEXprint**

## Sport Utility Vehicles

The sport utility vehicle, which combines the best features of a truck and a car, has become tremendously popular. These practical, hard-working vehicles offer four-wheel drive, heavily treaded tires, a chassis (body) which sits high off the ground, a strong engine and an especially roomy interior for passengers and cargo. Their weight and special features combine to provide benefits in daily travel as well as in hazardous weather conditions—including deep snow, ice, heavy rain and flooding. In addition, they are often used with trailers to pull loads like boats. One of their main drawbacks is that they use up fuel quickly.

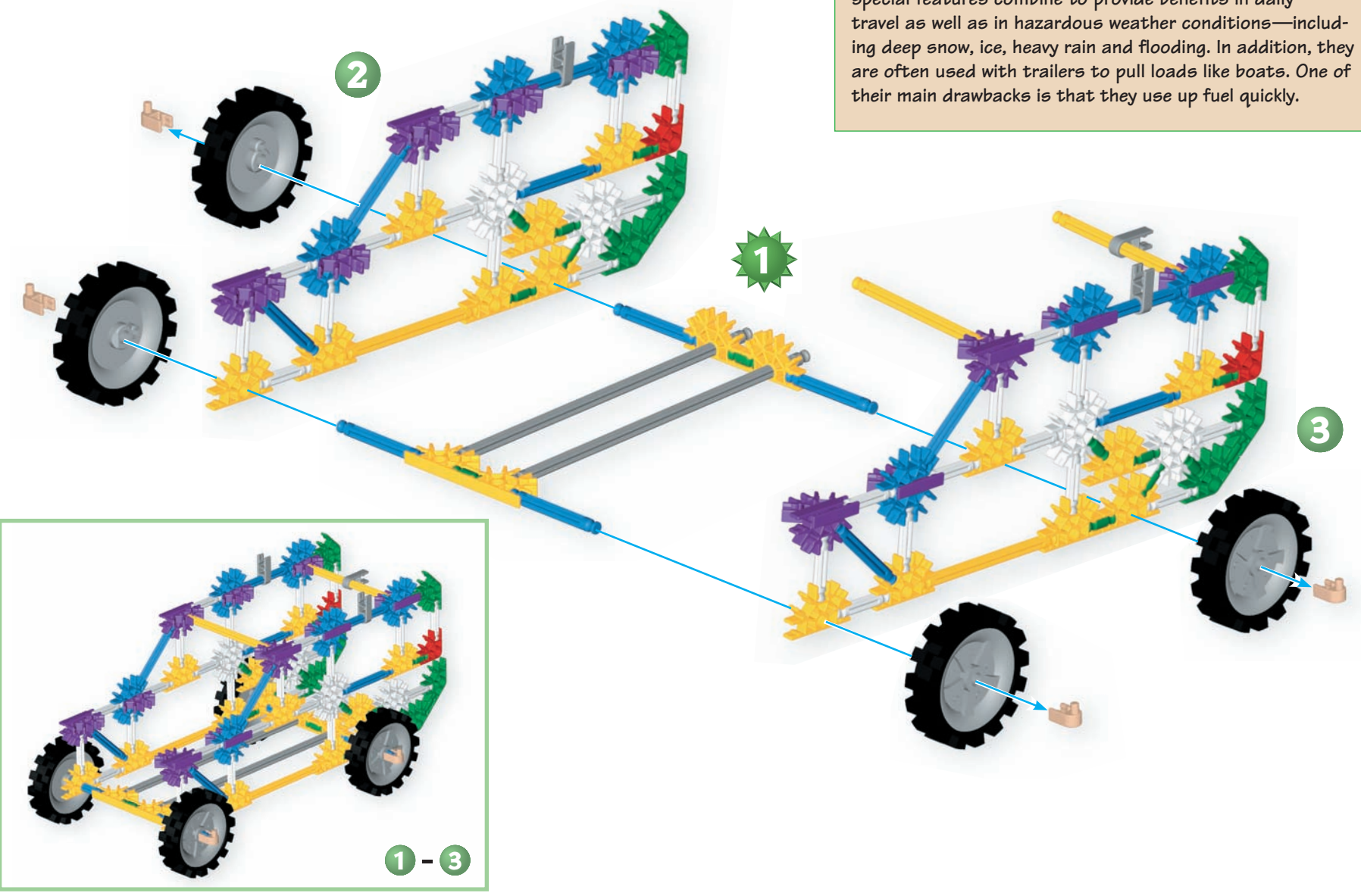

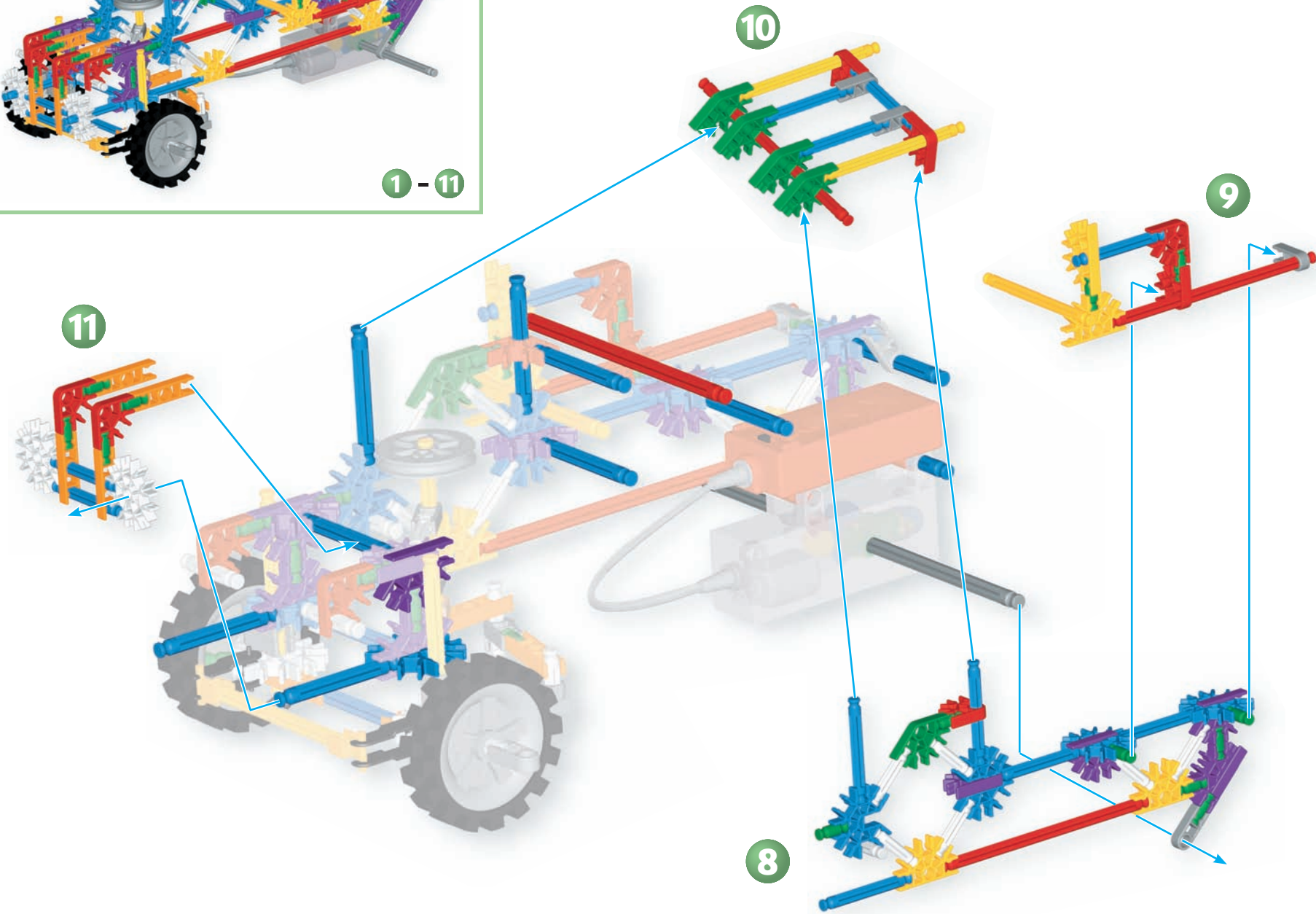
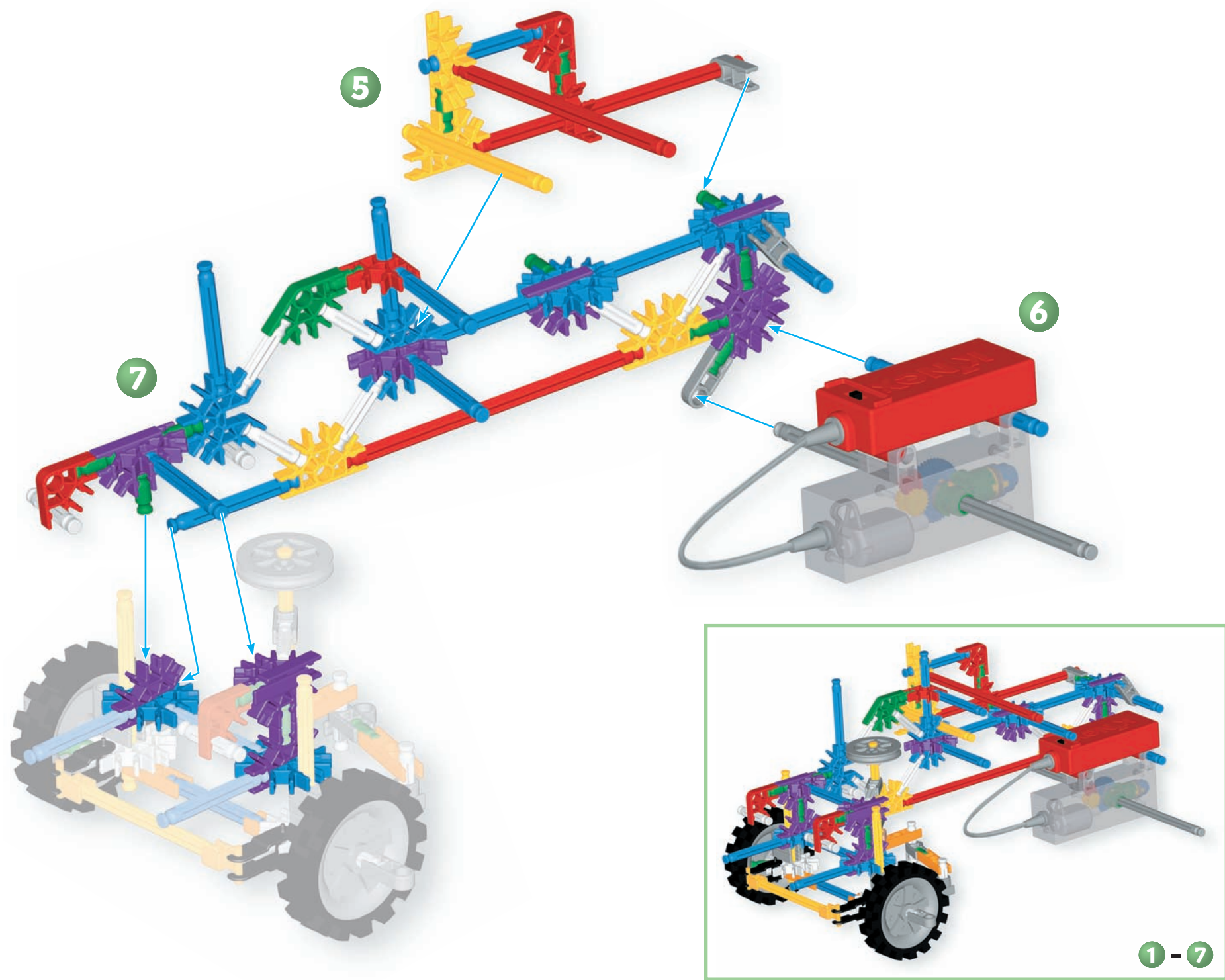

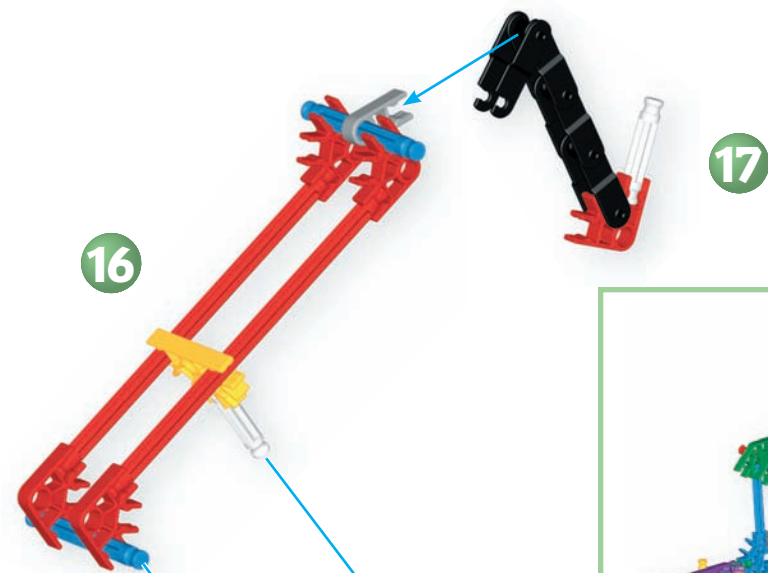
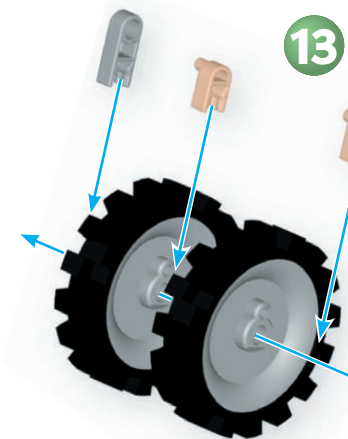

17



1 - 17

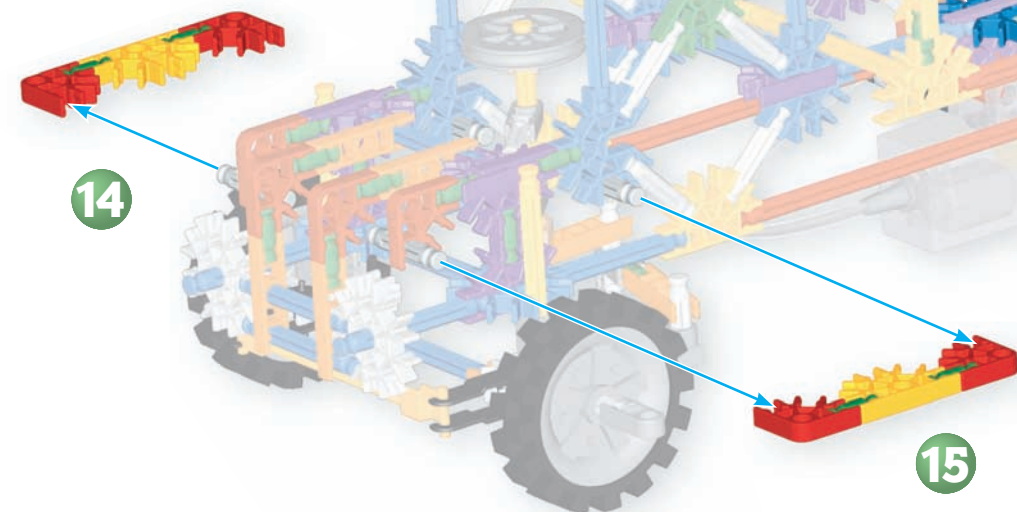

14

15

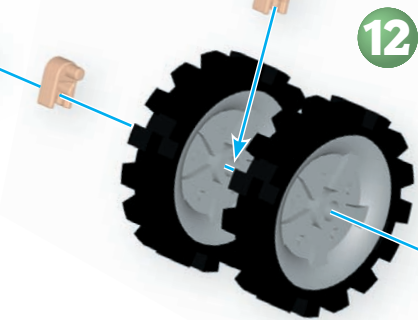

12

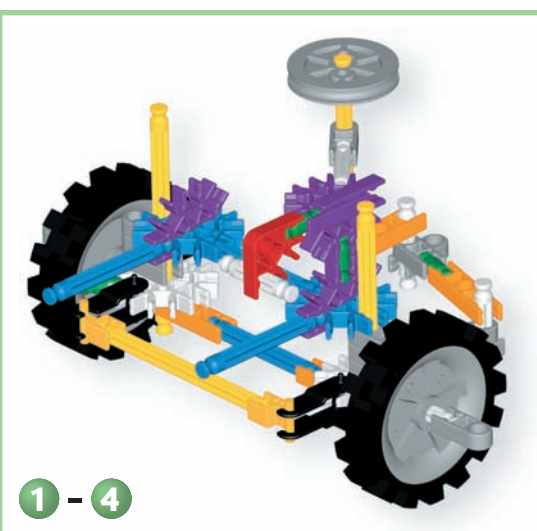

1 - 4

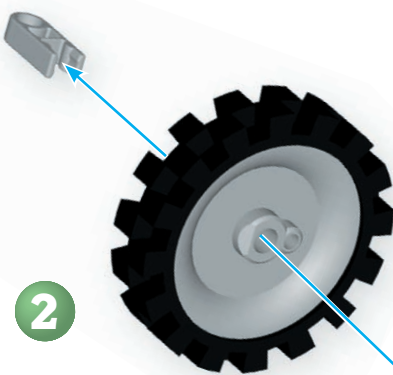

2

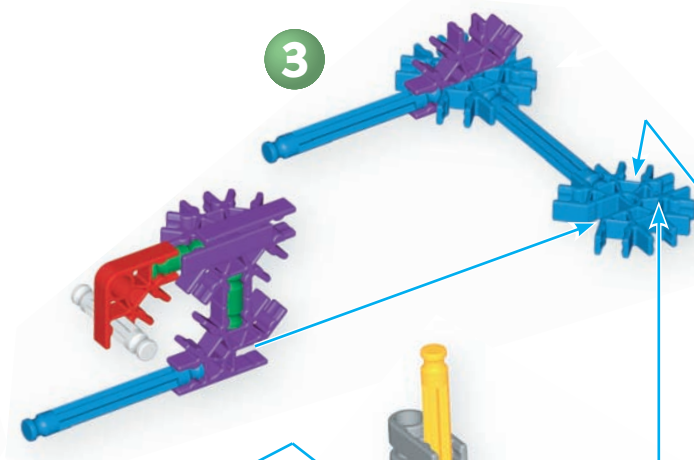

3

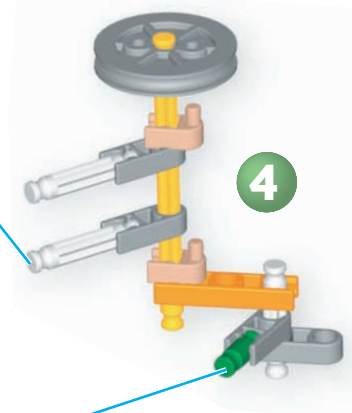

4



K'NEXprint

## Tow Trucks

Tow trucks are engineered to be rugged, powerful vehicles able to lift, carry or tow up to 20 times their own weight. Tow trucks are specially designed to haul vehicles behind them. Typically, these are disabled vehicles which must be taken from one point to another, most often for repair.

Equipped with cables, hooks and pulleys, tow trucks can attach a vehicle and drag it behind the truck on the vehicle's own wheels. Some tow trucks are equipped with a platform called a flatbed. The platform is used as an inclined plane onto which the disabled vehicle is loaded, secured and transported to its destination.

1	11
6	16
6	6
6	21
1	8
4	24
10	6
35	2
25	6
8	
8	
1	

# Airplane Towers With Runways

All large airports include two necessities – a control tower and a runway. Air traffic controllers, whose jobs are crucial to air travel safety, work from the tall tower, using its great visibility to monitor and guide all incoming and outgoing air traffic. By using radar and computers, they scan and keep track of aircraft in the airport's vicinity. Controllers communicate with aircraft by radio to provide directions and instructions. Other control tower staff keep track of weather and ground conditions which could affect a plane's landing and takeoff.

Most planes require runways to take off and land, with larger planes requiring very long runways in order to reach the speed necessary to provide liftoff. They also need lengthy runways for landing. Even with the engines cut off, the ailerons up, and the brakes applied, planes require great distances to come to a complete stop.

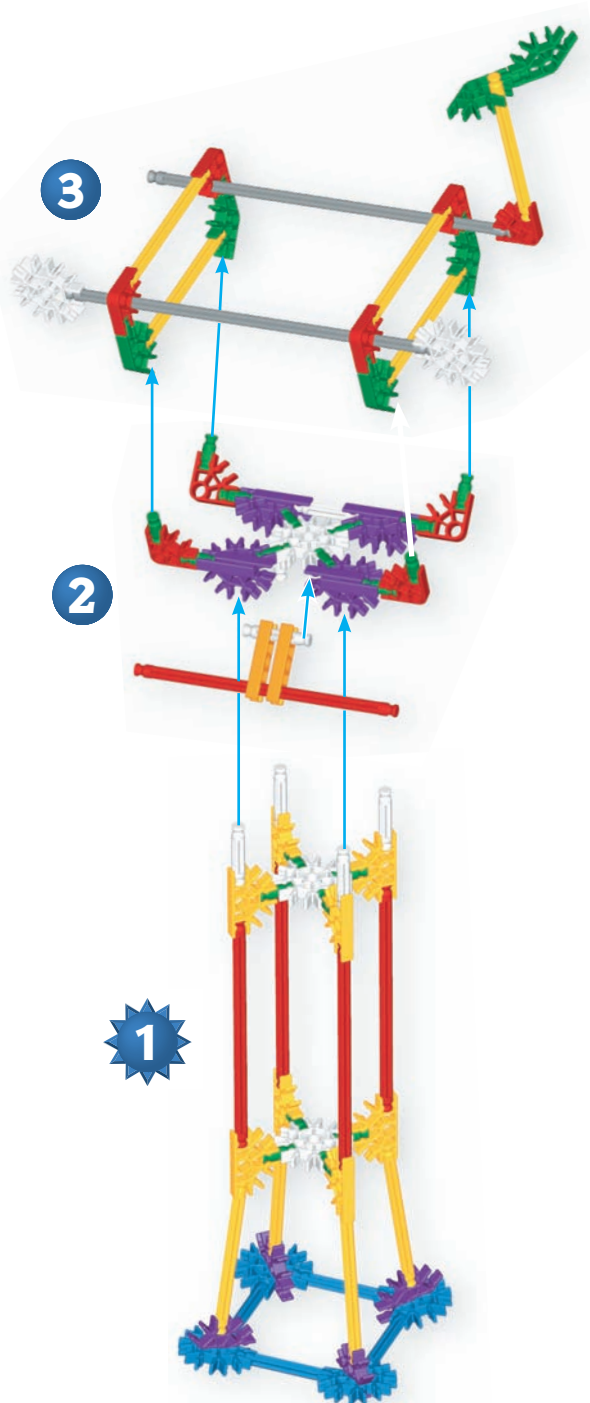

5	16	24	9	25	4	5
	8	6	2	18	9	2

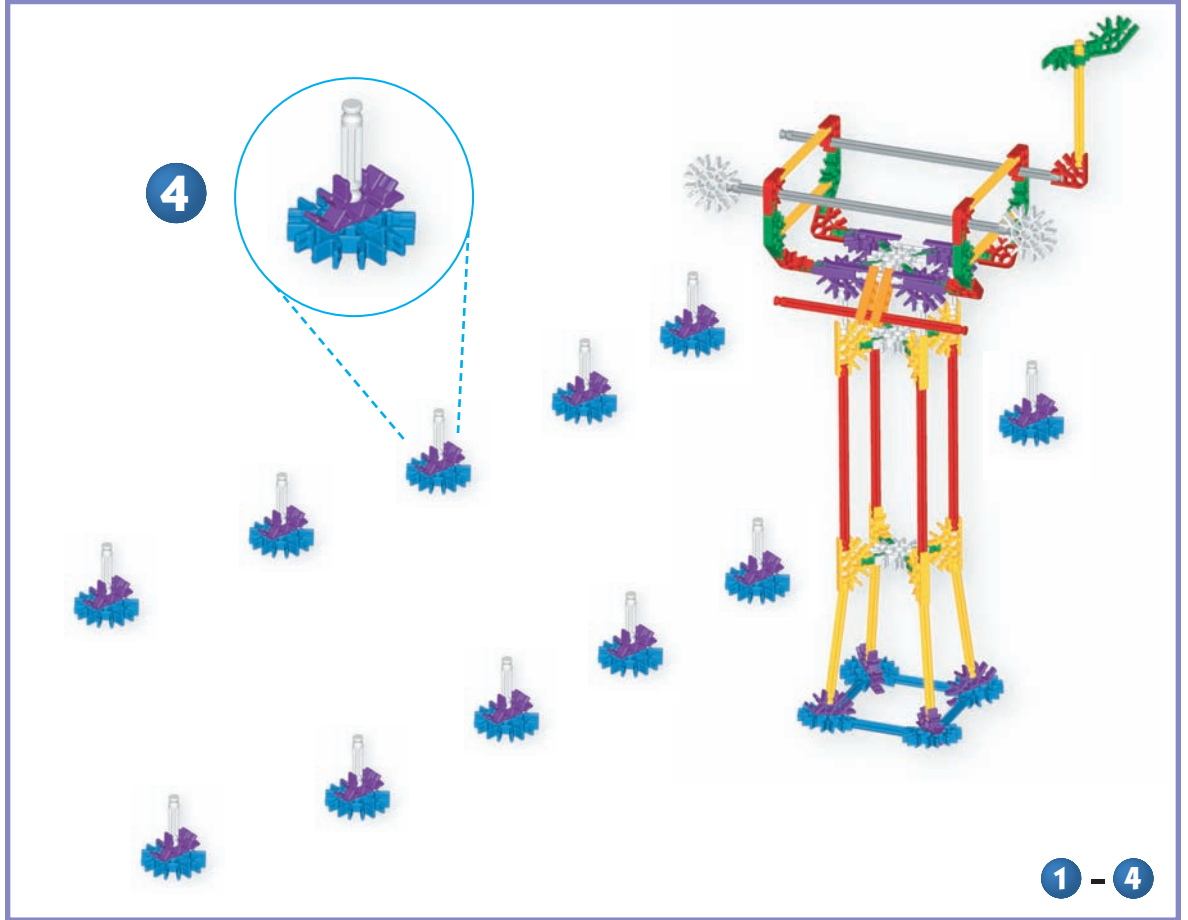

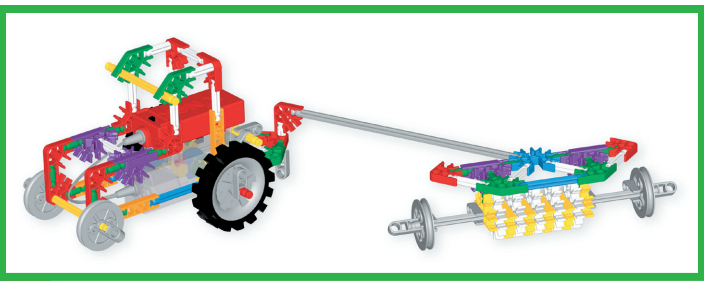

K'NEXprint

# Tractors, Hitches and Harrows

Tractors were designed to assist with the long, hard, tedious work of farming. These vehicles had to operate reliably on roads, grass, plowed fields and mud. Frequent travel on loose wet ground required that they use very large tires with deep, coarse treads that dig into the ground and roll over bumps and hollows smoothly and easily. The powerful engine drives the rear wheels; it also allows the tractor to tow and power heavy machinery like a harrow. Harrows use large spikes or teeth to cultivate and smooth soil.

Some tractors use rolling tracks made of rubber or steel called caterpillars that pack the surface of rough terrain and keep the vehicle moving. Modern tractors have enclosed cabs which protect the driver from the weather; others have roll cages to protect the driver should the tractor roll over.

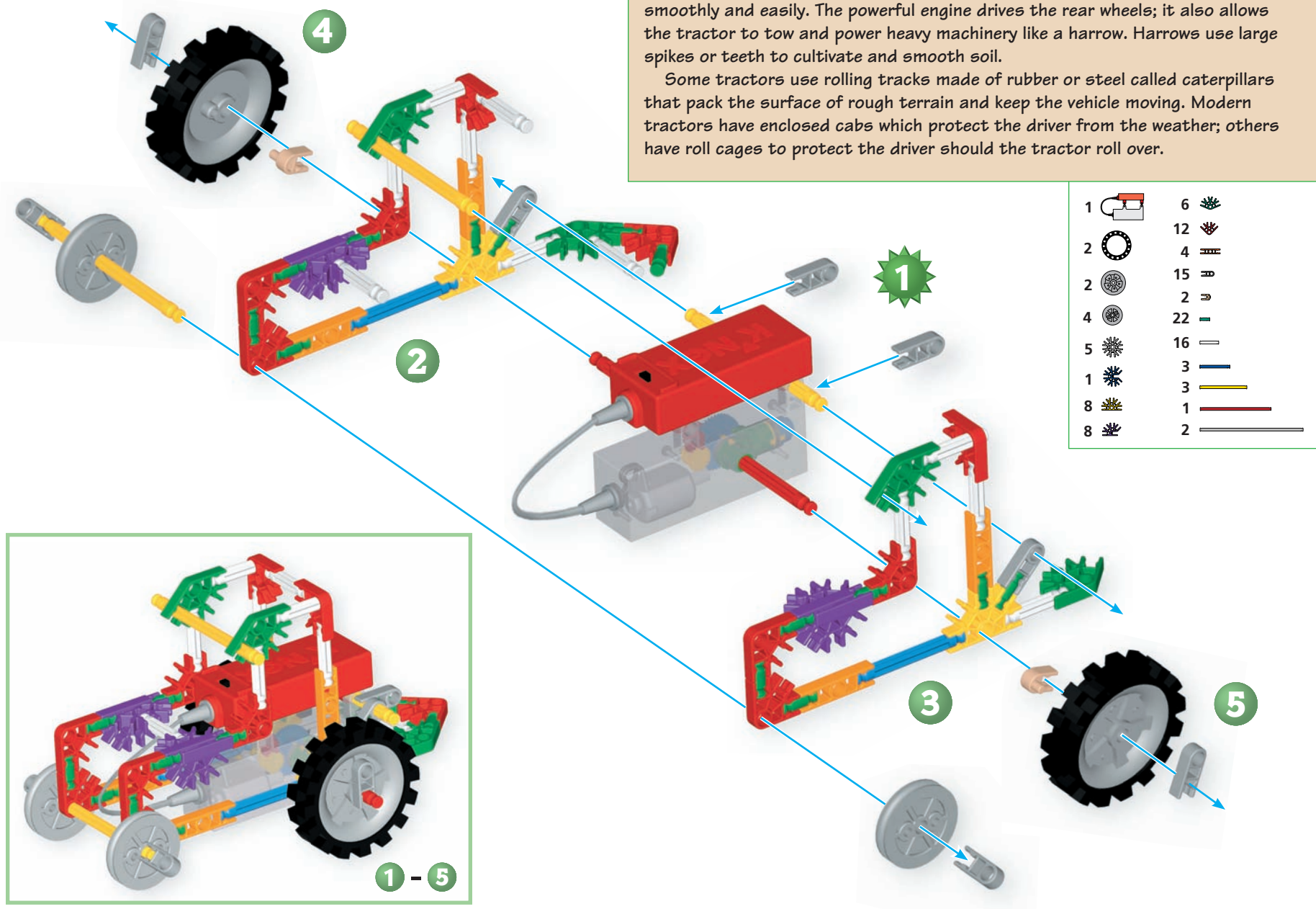

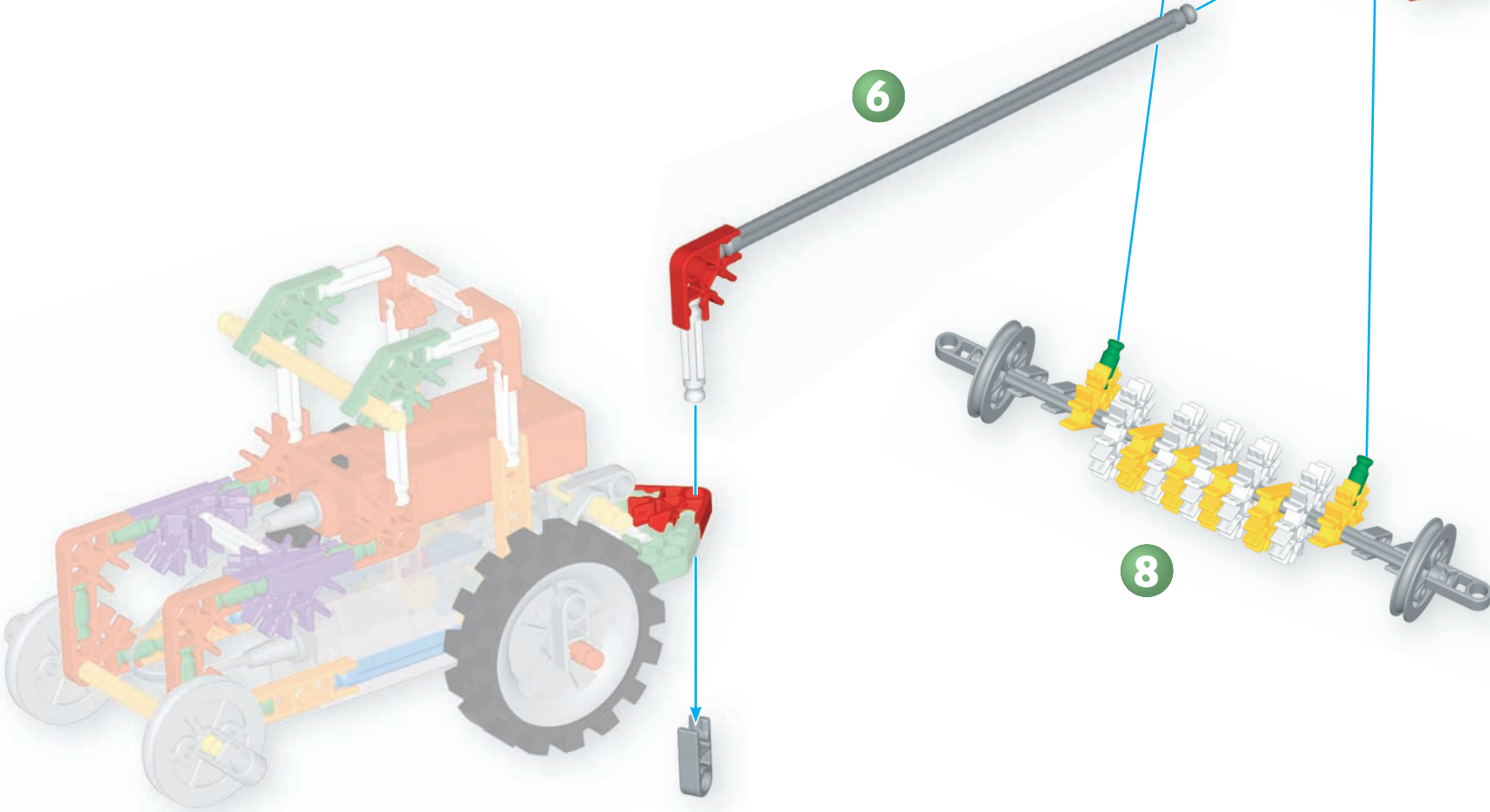
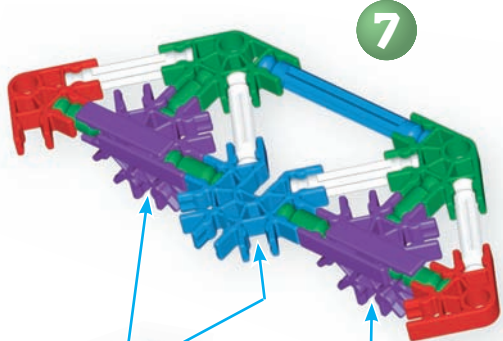
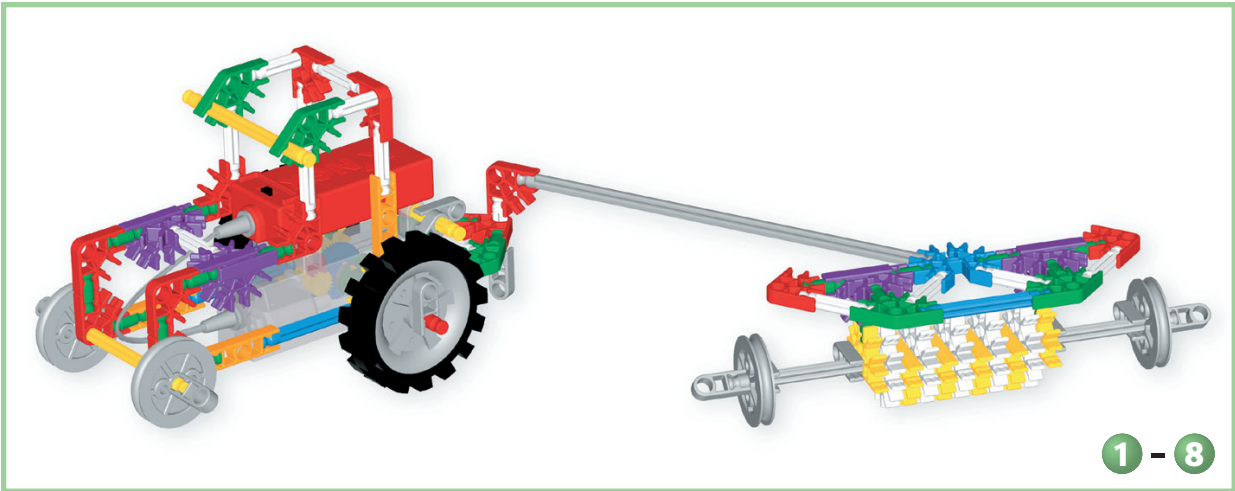

# Trains

Trains can carry hundreds of passengers and/or freight over long distances, under and above ground, connecting cities, towns and even countries. Early railway engines were powered by steam. Today, these engines have been replaced almost everywhere by electric and diesel engines.

Trains run on single (monorail) or double rails. Most have some type of wheels that travel along the rails, with individual train cars linked by

couplers. Electric trains take their electric current from a power plant and run it along the third rail or sometimes through an overhead line called a catenary.

In the future, trains will travel just above the track at speeds up to 310 mph (500 km/h) by being pulled (attracted) forward and pushed (repelled) by magnets in the rails. Due to speed and costs, magnet train (maglev) travel will likely replace air travel for people between neighboring cities.



# Ultralights

Ultralights, spin-offs of the hang glider, were designed for the experienced glider who wanted the benefits of added control provided by a motor. They run on lawnmower-sized gasoline engines for takeoff, landing and as a backup in flight should the winds die down and thermals not meet expectations.

Since they are extremely lightweight, less than 200 pounds (91kg) without a pilot, ultralights are affected by strong winds which can make staying on course and landing almost impossible. For this reason, some ultralight pilots use parachutes to land.

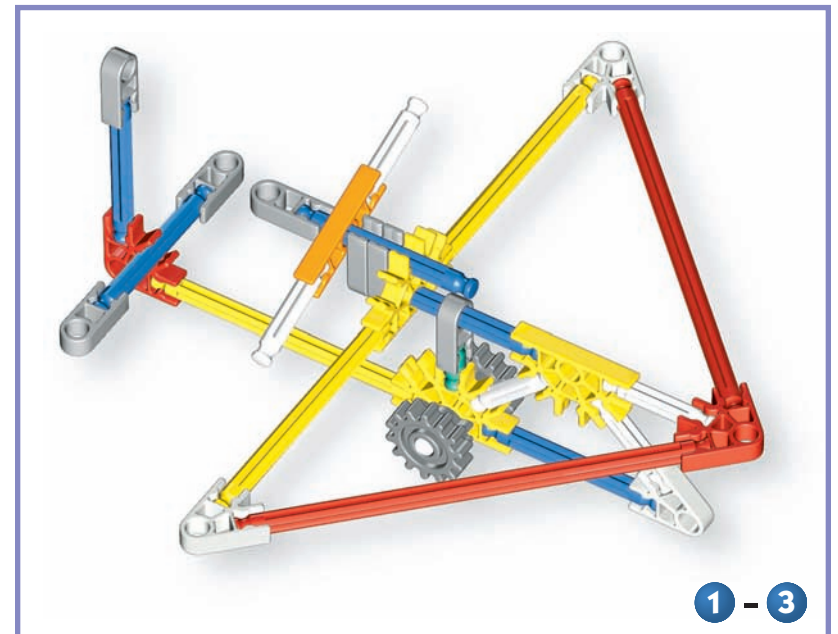
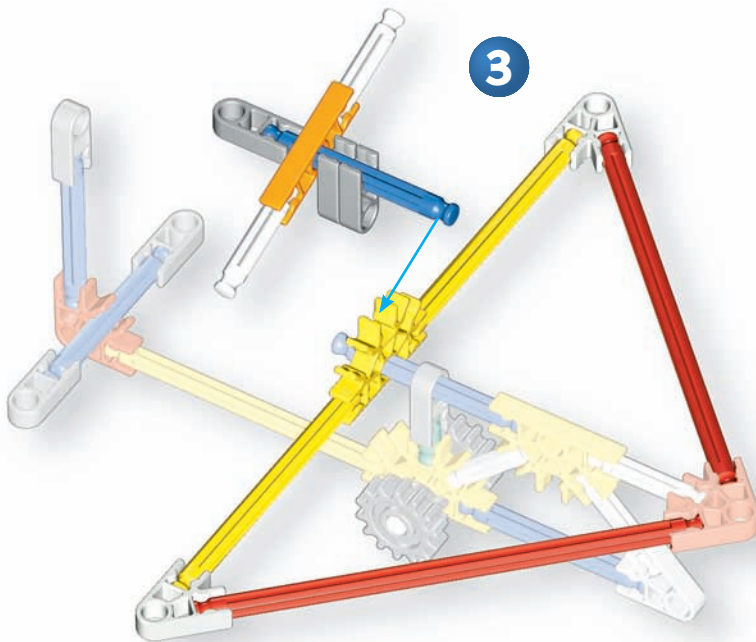
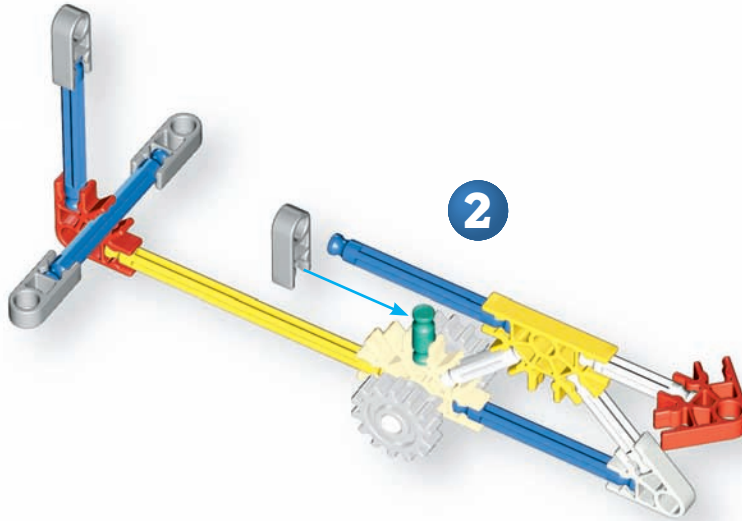
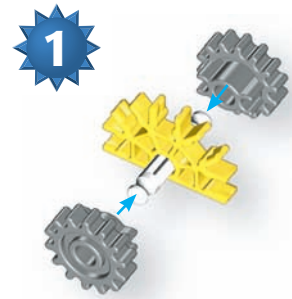

3		1		1		3	
2		7		6		2	
3		2		5			

K'NEXprint

## Viking Ships

From the 8th to the 11th centuries, Scandinavian warriors, known as Vikings, attacked the rich kingdoms and coastal communities of western Europe and traffic in the ocean waters of the North Atlantic. Most Viking ships were large and used for raiding and long voyages. Small Viking ships usually concentrated on coastal trading and river warfare.

Viking ships were usually sailing vessels that could also be powered by oars. They had sails in the middle of the ships with decking in front and behind. The vessel's crew rowed by inserting oars through square holes in the top border of the hull on both sides of the boat. Vikings are known for the rich, intricate craftsmanship of their ships. Their carved designs were very different from the rest of European art of the time.



# Motorcycles

The motorcycle, an outgrowth of the bicycle, relies on a small gas engine rather than leg muscle power to turn the wheels. The first motorcycles, built in the 1860's, were steam-powered and not very successful. The forerunner of the modern motorcycle, the Einspur, was a gas-engine machine built almost entirely of wood in Germany in 1885. Its top speed was 11.8 miles per hour (19 km/h).

By 1917, innovations led to a belt driven motorcycle and by the 1930's, motorcycles could travel 120 mph (193 km/h). Today's modern racers are streamlined to minimize air resistance so they travel faster and use less fuel. Broad soft rubber tires grip the track so these cycles can achieve speeds greater than 185 mph (298 km/h).

- |   |  |    |  |
|---|--|----|--|
| 1 |  | 2  |  |
| 3 |  | 2  |  |
| 3 |  | 2  |  |
| 2 |  | 10 |  |
| 2 |  | 5  |  |
| 7 |  | 3  |  |
| 5 |  | 2  |  |
| 3 |  |    |  |

