

KNEX[®]

Education[™]

TEACHER'S GUIDE

SIMPLE MACHINES DELUXE[™]
WHEELS & AXLES

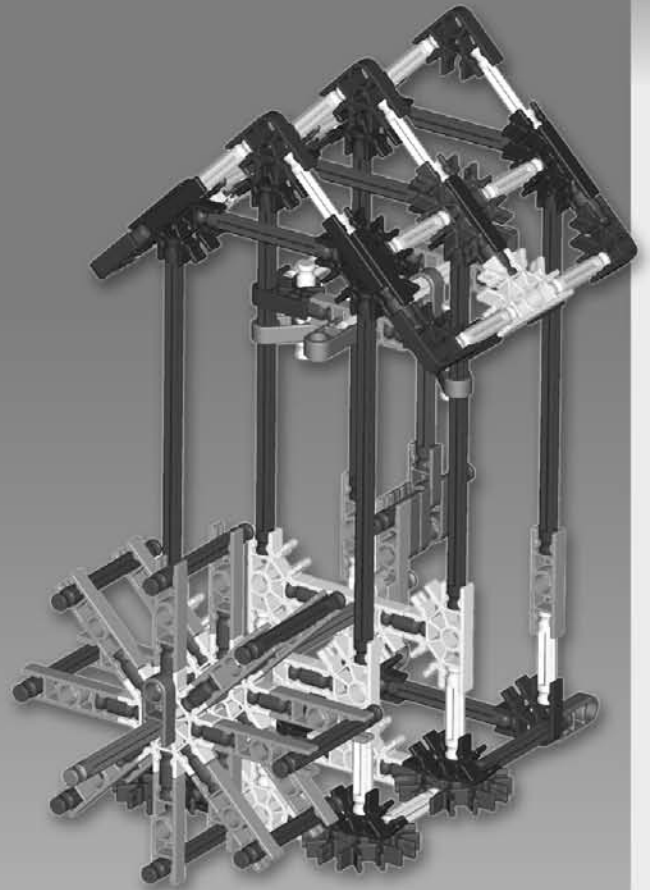
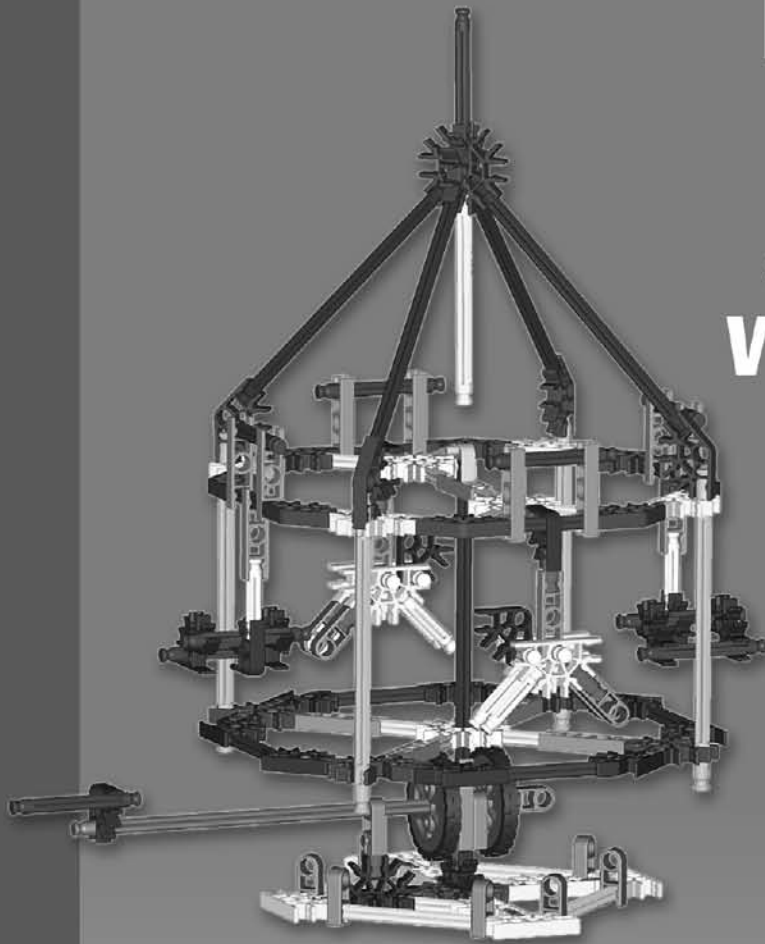

TEACHER'S GUIDE

SIMPLE MACHINES DELUXE™ WHEELS & AXLES

KNX 79520-V1-11/10
©2011 K'NEX Limited Partnership Group
and its licensors.

K'NEX is a trademark of K'NEX Limited Partnership Group.

Website: www.knexeducation.com
Email: abcknex@knex.com
Phone: 1-888-ABC-KNEX (USA/CAN only)

K'NEX Limited Partnership Group
P.O. Box 700
Hatfield, PA 19440-0700
USA



WARNING:

CHOKING HAZARD - Small parts.
Not for children under 3 years.



AVERTISSEMENT :

DANGER D'ÉTOUFFEMENT - Pièces de petite taille.
Ne convient pas aux enfants de moins de 3 ans.



Table of Contents

Simple Machines Deluxe Introduction	4
Standard Alignments	5
All About Wheels & Axles	
What is a Wheel & Axle?	8
Key Words and Definitions	8
Key Concepts	9
Student Reference Sheets	10
Spinning Top	
Lesson Plan	14
Student Activity Sheet	16
Wishing Well	
Lesson Plan	17
Student Activity Sheet	21
Wrench	
Lesson Plan	22
Student Activity Sheet	24
Screwdriver	
Lesson Plan	25
Student Activity Sheet	27
Ferris Wheel	
Lesson Plan	28
Student Activity Sheet	30
Water Wheel	
Lesson Plan	31
Student Activity Sheet	33
Paddlewheel Boat	
Lesson Plan	34
Student Activity Sheet	36
Windmill	
Lesson Plan	37
Student Activity Sheet	39
Measuring Wheel	
Lesson Plan	40
Student Activity Sheet	42
Wagon	
Lesson Plan	43
Student Activity Sheet	45
Carousel	
Lesson Plan	46
Student Activity Sheet	48
Part & Model List	49

Introduction:

OVERVIEW

This Teacher's Guide has been developed to support you as your students investigate the K'NEX Education Simple Machines Deluxe Set. In conjunction with the K'NEX materials and individual student journals, the information and resources here can be used to build your students' understanding of scientific concepts and channel their inquiries into active and meaningful learning experiences.

SIMPLE MACHINES DELUXE

This K'NEX Education set is designed to introduce students to the scientific concepts associated with simple machines. Students are provided with the opportunity to acquire skills using a hands-on, inquiry based approach to information and concepts. Working cooperatively, students are encouraged to interact with each other as they build, investigate, discuss and evaluate scientific principles in action.

TEACHER'S GUIDE

Designed as a resource for the teacher, this guide provides a glossary of key terms and definitions, includes an overview of the concepts associated with the different simple machines, identifies student objectives for each investigation, and offers plans and scripts to successfully present selected models and their associated activities. We have also provided Student Activity and Reference Sheets. These comprise illustrations and definitions of some of the concepts featured in the model building activities. Most lessons can be completed in 30 to 45 minutes. We recommend that teachers review their curriculum and science education standards to identify those activities that best support their academic needs.

STUDENT JOURNALS

It is expected that students will have journals available for recording information. They should be encouraged to enter initial thought at the start of an inquiry – what they “think” will happen. These initial thoughts may be amended, based upon their ongoing inquiry and analysis, until the students feel comfortable about drawing conclusions. Their journal entries will help make a connection between the models they have built, the experiments they have conducted, and how this information is applied to the real-world machines they use on a regular basis. The journals will also provide students with a place to practice making drawings and diagrams of systems. Finally, the journals will serve as a method of assessment for the Simple Machines units. Journal Checklists are also included in the Teacher's Guide for each model and its associated activities.

Alignment with National Standards Grades K-4

The National Science Education Standards

Unifying Concepts and Processes	<ul style="list-style-type: none">• Systems, order, and organization• Evidence, models, and explanation• Change, constancy, and measurement• Form and function
Physical Science	<ul style="list-style-type: none">• Properties of objects and materials• Position and motion of objects
Science and Technology	<ul style="list-style-type: none">• Abilities of technological design• Understandings about science and technology

Reprinted with permission from National Science Education Standards, 2001 by the National Academy of Sciences, Courtesy of the National Academies Press, Washington, D.C.

Alignment with National Standards Grades 5 - 8

The National Science Education Standards

Unifying Concepts and Processes	<ul style="list-style-type: none">• Systems, order, and organization• Evidence, models, and explanation• Change, constancy, and measurement• Form and function
Physical Science	<ul style="list-style-type: none">• Motions and Forces• Transfer of Energy
Science as Inquiry	<ul style="list-style-type: none">• Abilities necessary to do scientific inquiry• Understanding about scientific inquiry
Science and Technology	<ul style="list-style-type: none">• Abilities of technological design• Understandings about science and technology

Reprinted with permission from National Science Education Standards, 2001 by the National Academy of Sciences, Courtesy of the National Academies Press, Washington, D.C.

Alignment with Standards for Technological Literacy Grades 3-5

Standards for Technological Literacy	
The Nature of Technology	<p>Core Concepts of Technology</p> <ul style="list-style-type: none"> • Systems • Processes • Requirements <p>Relationships among technologies</p> <ul style="list-style-type: none"> • Technologies integrated
Design	<p>The Attributes of design</p> <ul style="list-style-type: none"> • Requirements of design <p>Engineering Design</p> <ul style="list-style-type: none"> • Engineering design process • Creativity and considering all ideas • Models <p>The role of troubleshooting, research and development, invention and innovation, and experimentation in problem solving</p> <ul style="list-style-type: none"> • Troubleshooting • Invention and innovation • Experimentation
Abilities of a Technological World	<p>Apply design process</p> <ul style="list-style-type: none"> • Collecting information • Visualize a solution • Test and evaluate solutions • Improve a design

Used with permission of ITEEA (www.iteea.org)

Alignment with Standards for Technological Literacy Grades 6 - 8

Standards for Technological Literacy

<p>The Nature of Technology</p>	<p>Core Concepts of Technology</p> <ul style="list-style-type: none"> • Systems • Processes • Requirements <p>Relationships among technologies</p> <ul style="list-style-type: none"> • Interaction of systems • Knowledge from other fields of study and technology
<p>Design</p>	<p>The Attributes of design</p> <ul style="list-style-type: none"> • Design leads to useful products and systems • There is no perfect design <p>Engineering Design</p> <ul style="list-style-type: none"> • Brainstorming • Modeling, testing, evaluating, and modifying <p>The role of troubleshooting, research and development, invention and innovation, and experimentation in problem solving</p> <ul style="list-style-type: none"> • Troubleshooting • Invention and innovation • Experimentation
<p>Abilities of a Technological World</p>	<p>Apply design process</p> <ul style="list-style-type: none"> • Identify criteria and constraints • Test and evaluate • Make a product or system

Used with permission of ITEEA (www.iteea.org)

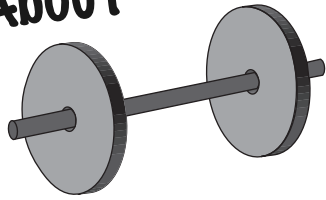

WHEELS & AXLES

What is a Wheel and Axle?

- A wheel is a round disk. An axle is a rod that runs through the center of the wheel and supports it.
- In a wheel and axle system, the wheel is fixed to the axle.
- Some wheels and axles do not have a round shape. However, they do move in a circular path when doing work.
- To use a wheel and axle, you (or wind, water or a motor) provide the effort by turning either the wheel or the axle.
- Wheels and axles can change the amount of force needed to do work, increase the distance covered and reduce friction, depending on how they are designed and used.

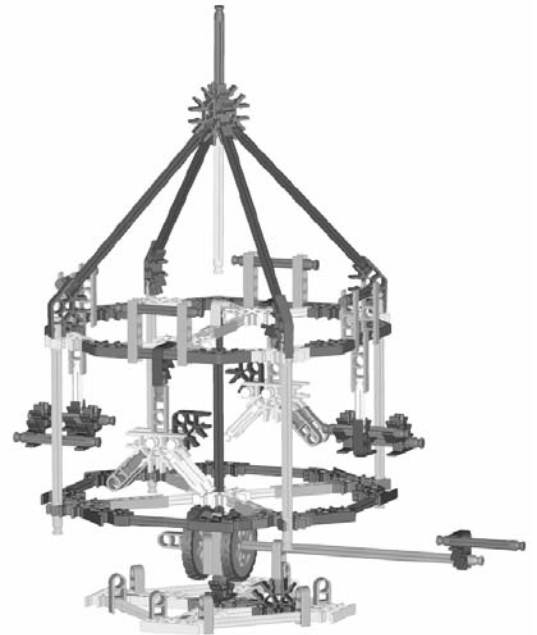

Key Words and Definitions

Effort - the force that is applied to do work; the push, pull, squeeze or lift provided to use a wheel and axle to move an object

Resistance - the force provided by the object on which one is trying to do work; the object works against (pushes back) the effort

Mechanical Advantage (MA) - a mathematical calculation that reveals how many times easier a job is to do when a wheel and axle is used;
effort radius (ER) ÷ resistance radius (RR) = MA

Work - the job being done while using the wheel and axle

Load - the object (weight) lifted or moved; provides resistance to the wheel and axle

Force - any kind of push or pull applied to an object

Friction - force resulting from one surface rubbing against another as an object moves

Circumference - the distance around a circle

Diameter - the distance through the center of an object; a straight line passing through the center of a circle ended at the circumference

Radius - a straight line from the center of a circle to any point on the circumference; half of the diameter of a circle

Key Concepts

How does a wheel and axle help you?

- Wheels and axles make work easier by making things easier to move.
- Like all simple machines, wheels and axles must move a load, the resistance, by using force.
- Force can be applied to turn the wheel where the axle provides the resistance.
- Force can also be applied to turn the axle where the wheel provides the resistance.

How does a wheel and axle affect force?

- Wheels and axles can reduce the amount of force needed to do a job. However, the force must be applied over a longer distance.
- Turning the wheel to make the axle turn has a MA greater than one. The job is easy; not much force is needed to turn the wheel but it is applied over a longer distance since the wheel is bigger than the axle.

How does a wheel and axle affect distance?

- Wheels and axles can reduce the distance over which a job is done. However, more force must be applied to do the work in a short distance.
- Turning the axle to make the wheel turn has a MA less than one. The job is hard; a lot of force is needed to turn the axle but it is applied over a shorter distance since the axle is smaller than the wheel.

How does a wheel and an axle affect friction?

- Friction is a force that occurs when surfaces rub against each other. It slows down a moving object.
- An object with a large surface area rubbing against another surface will create a lot of friction.
- Wheels and axles can reduce friction since only a small part of the wheel touches the surface at any given time. In these instances, there is less area for friction to occur.
- When used to reduce friction, the wheel may or may not be fixed to the axle. The wheel does not provide a Mechanical Advantage when used this way.

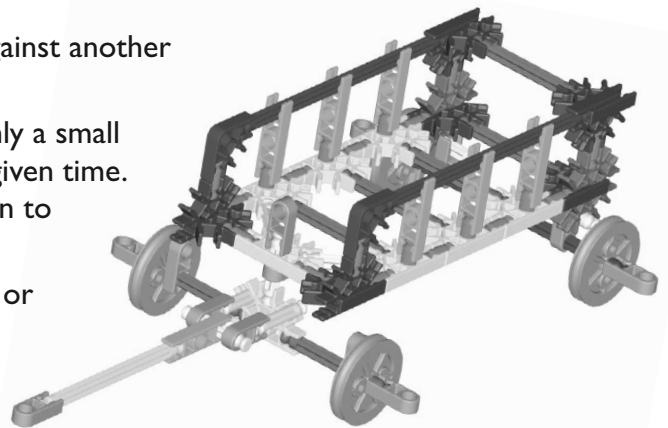

REMEMBER

Turning the wheel to make the axle go around helps do a job with more force. Turning the axle to make the wheel go around helps do a job over more distance at a faster speed.

Getting Started with Wheels and Axles

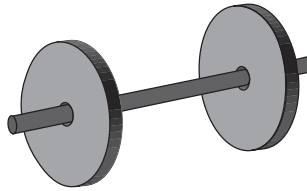

What is a wheel and axle?

- The wheel is a round disk. The axle is a rod that runs through the center of the wheel.
- In a wheel and axle system, the wheel is fixed (attached) to the axle.
- Wheels and axles can make work easier.
- Wheels and axles help make work easier by either increasing the force you supply to do a job or the distance you cover while doing the work.
- A wheel and an axle can also work together to reduce friction.



How does a wheel and axle help you?

Wheels and axles help in three different ways, depending on how they are designed and used. (For more information, see the other Wheels and Axles Reference Sheet.)

Force

Wheels and axles can reduce the amount of force you need to do a tough job. For example, it is easier to turn a car's steering wheel to turn a corner rather than pushing the car around the corner.

Distance

For some jobs, you need to move something a great distance or at a faster rate. Wheels and axles can help! You can get to the playground faster riding your bike than walking.

Friction

When you drag an object across the floor, a force called friction occurs. This force slows the object down. Wheels can help because they produce less friction than the object.

Here's an example of how wheels and axles can help.

Imagine you work for a zoo and you just received a new elephant from another zoo. The elephant, Moe, is scared so he won't move. How can you get this **HEAVY** elephant from the delivery zone into its new living quarters? Sounds impossible, but it's not if you use wheels and axles!

Picture this.

You attach a rope to Moe, the elephant, and pull hard to drag him along the ground all the way to his new living area.

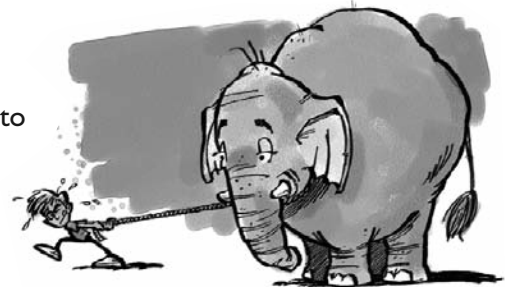

This would be exhausting and maybe impossible. Now, picture the elephant on a trailer with four wheels and a rope attached to the trailer. As you pull, it takes a lot less force to get the elephant rolling and moved into his new home.

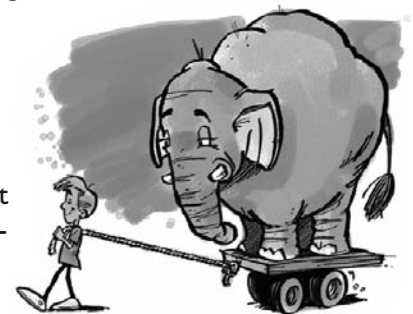

A Bright Idea!

The wheel and axle is probably one of the first simple machines ever used—perhaps dating back to the caveman. Do you think early man may have used this machine in his everyday life? Conduct research to find out if your ideas are valid.

What's the Mechanical Advantage?

How much do wheels and axles help you?

Do some measuring and dividing to see how much wheel and axle systems make work easier.

- 1 To make a wheel and axle work, you either turn the wheel or the axle. You (or wind, water or motor) supply the *effort*.

Measure the diameter of either the wheel or the axle — whichever one provides the effort. Then, divide the diameter in half to get the **effort radius (ER)**.

$$\text{Diameter of wheel or axle supplying effort} \div 2 = \text{ER}$$

- 2 The wheel and axle along with any weights they move, provide the *resistance*.

Measure the diameter of the wheel or axle — whichever one isn't providing the effort. Then, divide the diameter in half to get the **resistance radius (RR)**.

$$\text{Diameter of wheel or axle not supplying effort} \div 2 = \text{RR}$$



Imagine that you have a windmill that grinds grain. The effort is supplied by the wheel and the resistance is supplied by the axle. The diameter of the windmill's wheel (its blades) is 40 meters. (See step 1)

$$40 \div 2 = 20 \quad \text{ER} = 20$$

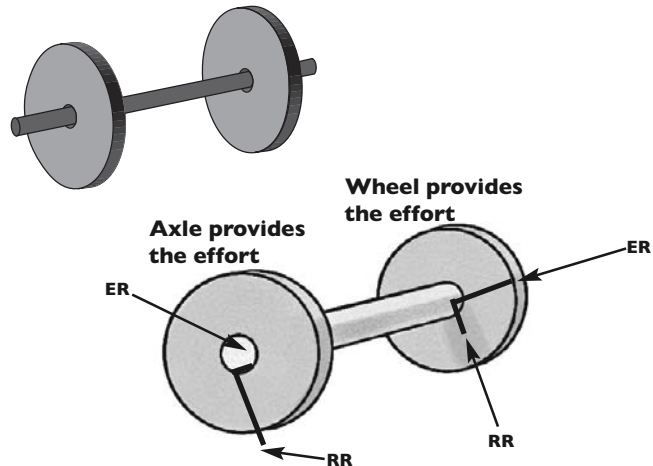

- 3 Now divide to find the **Mechanical Advantage (MA)**.

$$\text{ER} \div \text{RR} = \text{MA}$$

The MA tells you how many times easier the job is using a wheel and axle system.

Something Surprising!

When you turn the wheel to make the axle turn, the MA is greater than one (1). This means your job is easier. The axle turns with greater force than you're putting in, but you have to turn for a longer distance. The wheel of a windmill supplies a large force to its axle to do big jobs.

When you turn the axle to make the wheel turn, the MA is less than one (1). Your job is harder than just turning the wheel would be. But you turn the axle a shorter distance than the wheel turns. A paddlewheel boat has plenty of power to turn its axle, so it can make its wheel turn in a big circle to paddle the water.

Describe some Wheel & Axle examples where the axle turns from effort and where the wheel turns from effort.

The diameter of the windmill's axle is 2 meters. (See step 2) Divide to get the Mechanical Advantage.

$$2 \div 2 = 1 \quad \text{RR} = 1$$

The Mechanical Advantage is 20, which means that this wheel and axle makes grinding the grain 20 times easier than doing it by hand.

$$\text{MA} = 20 \div 1 \quad \text{MA} = 20$$

How Is a Wheel Like a Lever?

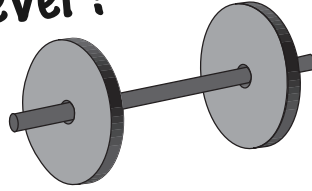

But first-what's a lever?

A *lever* is a simple machine. It's a stiff bar with a special spot called the *fulcrum*. When you use a lever, the fulcrum sits still as the rest of the bar moves around it. Just picture yourself and a friend on a see-saw. You move, but the fulcrum (the turning point in the middle) stays in one place.

Your friend, sitting on one end of the see-saw, is the *resistance*, or load, that you have to lift. When you hop on the other end, you provide the *effort* to lift your friend into the air.

What does that have to do with wheels and axles?

A wheel and axle acts as a lever that rotates, or spins around, rather than just going up and down.

Picture how a wishing well uses a wheel and axle to lift a bucket of water. The rod across the top is the axle and the crank, which turns in a circle, is the wheel. When you provide the effort by turning the crank, the rod turns, winding up a rope to raise the bucket, which is the resistance.

When you push on the crank, it's like pushing down on one end of a lever. You push down, and the bucket comes up, just like your friend on the see-saw.



Wheels, Axles and Force

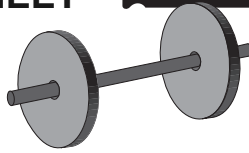

Turning the Wheel Makes the Axle Turn With More Force

When you turn a wheel, such as a water wheel, you make the axle turn too. As you make a full turn, the wheel turns in a big circle, while the axle turns in a small circle.

Since the wheel travels a long distance, it doesn't need much force. That means that turning the wheel is easy for you, even though you have to turn a long way. The axle, however, only travels a short distance, so it turns with greater force. With this extra force, the axle can lift a heavy weight or run a powerful machine.



Wheels, Axles and Distance

Turning the Axle Makes the Wheel Turn a Greater Distance

Some wheels and axles work by turning the axle which makes the wheel turn. A paddlewheel boat is one example. For each full turn, the axle turns in a small circle, while the wheel turns in a big circle.

Since the axle only travels a short distance, it needs a large force to turn. That means that turning the axle is hard, but you don't have to turn very far. The wheel, however, turns with less force, but it travels a long way. The extra distance lets you cover a lot of ground if you're riding a bike or paddle through a lot of water on a paddlewheel boat. So remember, turn hard to go a long way.



Wheels, Axles and Friction

Wheels make moving things less of a drag

Dragging or shoving a heavy box across the floor takes a lot of muscle power. It would be easier to put the box in a wagon and roll it. Wheels make moving things easier, because the wheels and the floor don't rub against each other.

Wheels help reduce **friction** - the rubbing of one surface against another. Since only a small part of the wheel

touches the ground at any given time, there isn't much area for friction to occur.

Just think of a car. Its four tires only touch a few square meters of the ground, even though the car itself covers a large area. As a result, moving the car down the road doesn't produce much friction. However, the wheels need some friction to grip the ground, so that the car won't slip and skid.



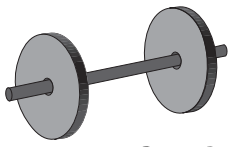

Spinning Top Lesson Plan

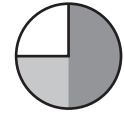

Lesson Length: 30-45 minutes

Objectives

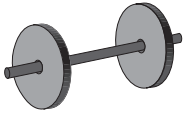

- Identify the wheel and axle on a spinning top
- Demonstrate how a spinning top functions as a wheel and axle
- Determine if a spinning top helps do a job with more force or more distance and speed
- Determine how wheel size affects spin time
- Determine how axle length affects the ability and duration of spin
- Give examples of spinning machines that do work and describe the work they do
- Practice math skills for timing events and finding an average

Materials

- stopwatch or clock with a second hand
- extra K'NEX pieces including Hubs

Journal Check

- ✓ Spin times of Spinning Top before and after change of wheel size (students may graph these results)
- ✓ Explanation for affect of wheel size on spinning time
- ✓ Explanation for affect of axle length on spinning ability
- ✓ List of equipment that spins to do work and the work they do

Every wheel and axle has a job to do

The stem of the Spinning Top is the axle, and when you spin the top, you are turning the axle quickly. The axle turns through a small circle, but the wheel turns through a larger circle in the same amount of time. This means that the wheel turns faster. As long as it's turning fast, the Spinning Top will keep its balance.

How does the Spinning Top help you?

Turning the Spinning Top's axle makes the wheel spin; it covers more distance, spins fast and keeps the Top going.

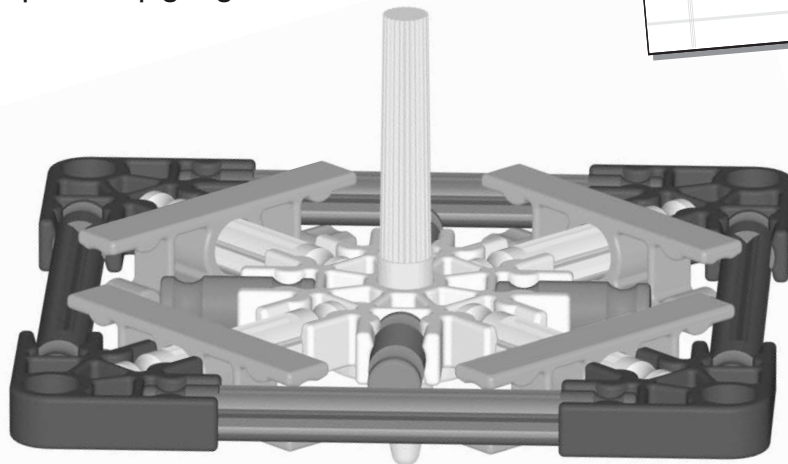

QUESTIONS

- 1 a. Use a clock or stopwatch to time how long your Spinning Top spins. Do the test a few times and compare the results. Work in an open area so the Top can spin freely.
 - b. Identify the wheel and the axle on your Top. Change the wheel size by adding or taking off K'NEX pieces. Time how long your Top spins now. Does it spin longer with a smaller or larger wheel?
- 2 Make a simple K'NEX Top from a blue Rod, a Hub or white Connector and a tan Connector. Test the top. Then, change the stem to a yellow or red Rod and test it again. Does the stem length change how the Top spins? How about the shape? Try putting a pen/pencil in the center.

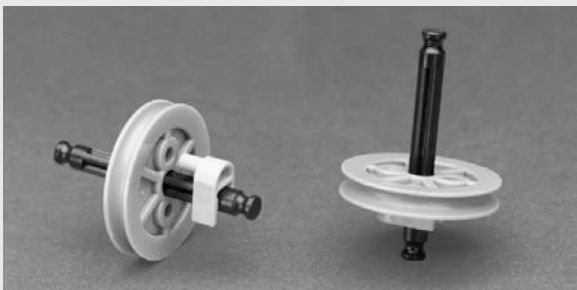

- 3 The Spinning Top is a toy but there are other types of equipment whose spinning actually does work. Can you name some? What kinds of work do you think these devices could do?

ANSWERS

- 1 a. Testing the top several times will provide a more reliable picture of how long the Top can spin. If students only test the top once, that one test could be unusually short or long. You might have the students average the times from several tests to get a spinning time that is typical for the Top.
 - b. The wheel is the flat part of the Top made from Connectors and Rods. The axle is the yellow stem you spin. When redesigning the wheel, students need to make them symmetrical, so the Tops will be balanced to spin well. Students may find that changing the size of the wheel affects how stable it is and how fast it spins. A Top with a large wheel, given a good start, will spin longer than one with a small wheel. Ask the students to graph their results for comparison.
- 2 Changing the length of the stem changes the Spinning Top's center of gravity, so it may affect how much the Top wobbles, which may affect how long it spins.
- 3 Students' answers will vary but should include machines that use spinning or turning to cover more distance.

The Spinning Top

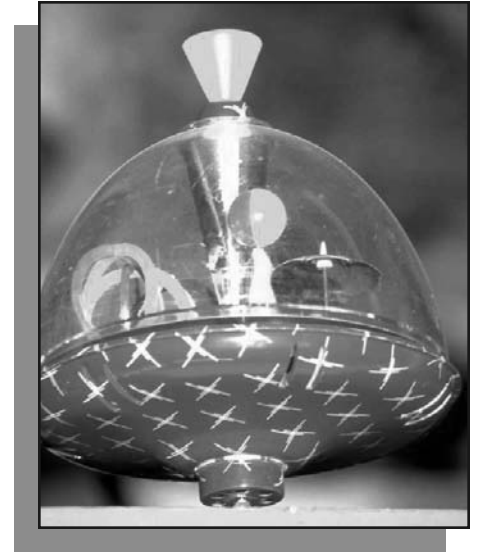
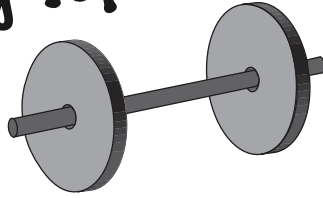

Every wheel and axle has a job to do

With a quick spin of the stem, the top twirls and twirls. It makes a swirl of colors and it keeps its balance longer than you might expect! Tops are just for fun, but they use a wheel and axle to do their job of going round and round.

How does the Spinning Top help you?

Put your Spinning Top to work.

- Did you turn the wheel to make the axle go around? If so, your machine helps you do a job with more Force.
- Or did you turn the axle to make the wheel go around? If so, your machine helps you cover more Distance at a faster speed.

Student Challenge

- 1 a. Use a clock or stopwatch to time how long your Spinning Top spins. Do the test a few times and compare the results. Work in an open area so the Top can spin freely.

b. Identify the wheel and the axle on your Top. Change the wheel size by adding or taking off K'NEX pieces. Time how long your Top spins now. Does it spin longer with a smaller or larger wheel?

- 2 Make a simple K'NEX Top from a blue Rod, a Hub or white Connector and a tan Connector. Test the top. Then, change the stem to a yellow or red Rod and test it again.

Does the stem length change how the Top spins? How about the shape? Try putting a pen/pencil in the center.

- 3 The Spinning Top is a toy but there are other types of equipment whose spinning actually does work. Can you name some? What kinds of work do you think these devices could do?

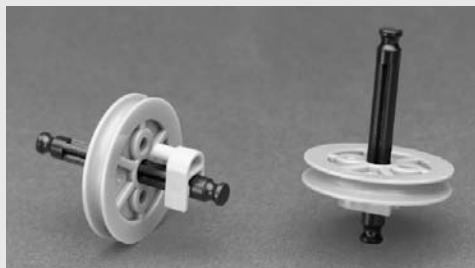

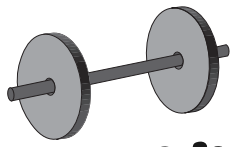

Wishing Well Lesson Plan

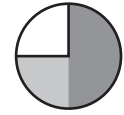

Lesson Length: 30-45 minutes

Objectives

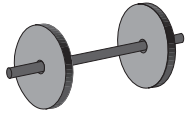

- Identify the wheel and axle on a wishing well
- Demonstrate how a wishing well functions as a wheel and axle
- Determine if a wishing well helps do a job with more force or more distance and speed
- Measure forces applied to wheels and axles using a Rubber Band Scale
- Take distance measurements for varying size wheels and axles
- Compare distance measurements to Wishing Well function and infer relationships
- Investigate how the size and shape of a wheel and an axle each affect force measurements and work performed

Materials

- two classroom desks
- tape measure
- K'NEX Rubber Band Scale
- extra K'NEX pieces or small objects to serve as weights
- small cup

Journal Check

The following items should reflect experiments and results presented for each of the Wishing Well wheel and axle combinations.

- ✓ Identification of wheel and axle
- ✓ Dimensions of wheel and axle
- ✓ Explanation of relationship between distance dimensions and Wishing Well function
- ✓ Force measurements and comparisons
- ✓ Explanation for which combination was most effective

Every wheel and axle has a job to do

A wishing well is a structure that is built over a deep hole in the ground. People dig wells to get water from underground. The structure, with its wheel and axle, makes it easier to haul up the heavy water bucket. These wells are sometimes called wishing wells due to a tradition where people toss a penny into the well and make a wish.

How does the Wishing Well help you?

You turn the wheel, so the Wishing Well helps you do a job with more force. It helps raise a heavy bucket of water from very far down in the ground.

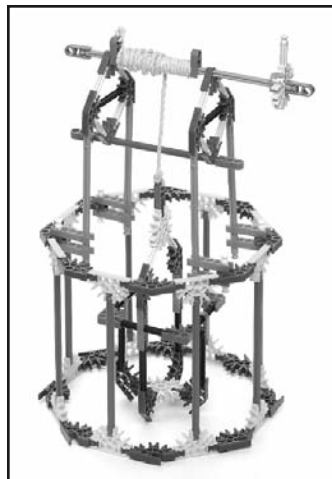

QUESTIONS

- 1 Build and place your Wishing Well on two desks set several centimeters apart so the bucket hangs down between them. Place a cup filled with small weights (like pennies, green Rods, etc.) in the bucket. Attach the K'NEX Rubber Band Scale to the bucket. Measure and record the force needed to lift this weight.
- 2 For each wheel and axle combination (1–6), build the model and attach it to your Wishing Well. Experiment and test each one and answer these questions.
 - a. Which part is the wheel and which is the axle? (Note: Sometimes the wheel is not easily identified.)
 - b. Each time the wheel makes one complete turn, the bucket is raised a short way. Use a measuring tape to measure the distance around the axle and the outside edge of the wheel. Compare the two measurements. How many times do you have to turn the wheel to raise the bucket to the top? Compare this to how many times the axle is turned. What does this tell you about the way the Wishing Well works?
 - c. Attach the K'NEX Rubber Band Scale to the axle and measure the force used to lift the bucket. Then, measure the force with the Scale attached to the wheel. Record your measurements.
 - d. Based on the amount of force used, did this wheel and axle make lifting the bucket harder or easier than lifting the bucket by itself? Why?
 - e. Which wheel and axle makes lifting the bucket easiest? Compare the measurements from the Rubber Band Scale. Why was this combination so helpful?

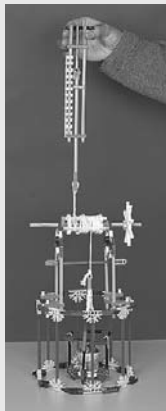

ANSWERS

- 1 Students need to measure the force used to lift the cup by itself in order to have a base from which to compare how much the machine helped do the work.
- 2
 - a. The wheel is the part that the user turns by hand. The axle is the part that the string wraps around. To help students visualize the handle on the Wishing Well as a wheel, use K'NEX, string or tape to add a rim to the wheel. Note that even a single white Rod, serving as a crank handle, can act as a wheel, because it traces out the path of a wheel as it moves.
 - b. For the axle, they should measure around the Rods that serve as the path that the cord takes. For the wheel-handle, they should measure around the outside tips of the wheel or the Rods (or measure the distance between the tips of adjacent white Rods and multiply by 8).
 - c. Answers will vary for each of the wheel and axle combinations but generally the students should find that using the wheel and axle makes lifting the bucket easier even though it is done over a longer distance (meaning more string is needed). Also, the bigger the wheel, the easier it is to turn the axle.
 - d. In most of the combinations, the axle's circumference is smaller than the circumference of the wheel's handle. That means that they have to turn the wheel more times than the distance the bucket moves. The combination with the largest wheel and the smallest axle will make it easiest to lift the bucket.
 - e. Students should find that it takes more force to turn the axle than to turn the wheel-handle. Therefore, using the wheel makes lifting the bucket much easier, even though it must be turned a greater distance.

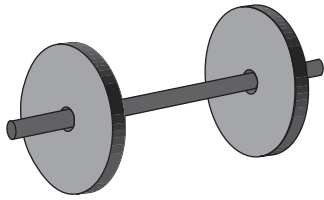

The Wishing Well Wheel & Axle Reinforcement Activities

Wheel and Axle Combinations

When using a wishing well, you provide the effort by turning the wheel to raise the bucket of water, which is the resistance. This means that the wheel and axle helps you do the job with more force.

The Wishing Well Wheel and Axle Combinations are provided so students can compare and contrast wheels and axles of different sizes to determine how they affect effort required and work performed. The weight in the bucket **must** remain constant throughout the experiments in order to ensure comparable results.

When garnering the force measurements with the Rubber Band Scale, students should compare measurements with the Scale attached to the axle (as stated on the Activity Sheet) and also to the wheel. The students should answer all of the questions for each combination before moving on to a new configuration. Then they can compare their results and draw conclusions.

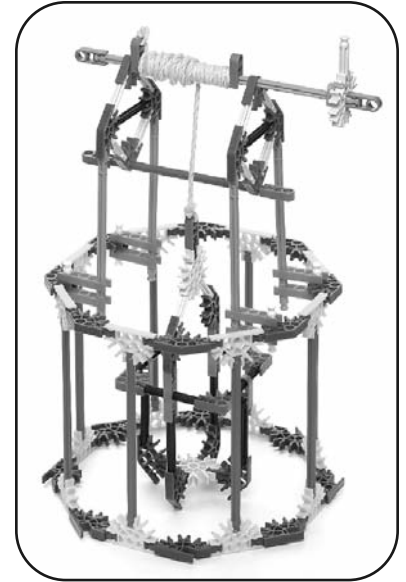

Combination 1, which consists of a small axle, the gray Rod itself, with a large wheel, demonstrates how the wheel and axle functions like a lever that rotates rather than just going up and down. Students push down on the white Rod (the effort arm of the lever) to make the resistance go up. The only difference is they continue pushing the lever so it rotates all the way around in a circle, which is what also makes it a wheel.

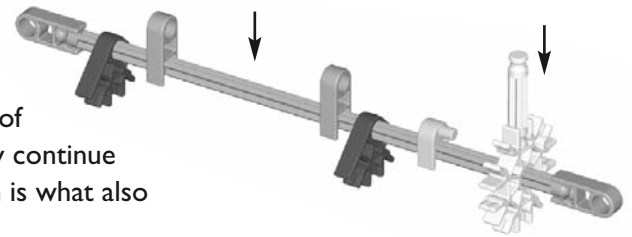

Combination 2 begins a progression which will demonstrate how the size of the wheel and axle affect the amount of effort required to do the work. By the end of the tests with Combination 4, students should understand that the bigger the wheel, the smaller the force needed to rotate it. This combination consists of a large axle (10 cm) and a very small wheel which is only the circumference of the gray Rod (2 cm). Students will find it difficult to raise the bucket with this combination and they have to apply a lot of force.

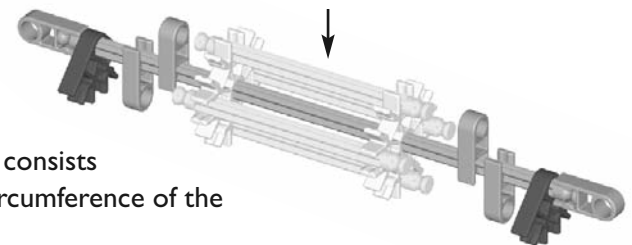

Combination 3 uses the same axle (10 cm) with a larger wheel (14.5 cm). The students will feel a significant difference in lifting the bucket with this combination because of the dramatic increase in the size of the wheel. This difference will be reflected in their force measurements. Reinforce that the difference is based on the increase in wheel **size** which is **unrelated** to the fact that this actually “looks” like a wheel. Appearance has nothing to do with this, only function does.

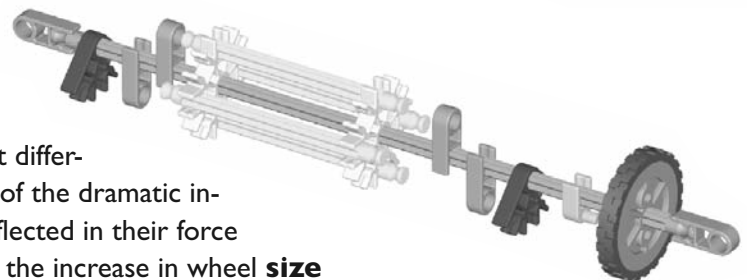

Combination 4 uses the same axle is in use with a circumference of 10 cm but the wheel size is increased to 26 cm. The amount of force needed to lift the load will again be decreased. At this point, you may ask advanced students to determine if there is a correlation between the incremental wheel size increases and the decrease in the amount of force. They should figure out and record this ratio.

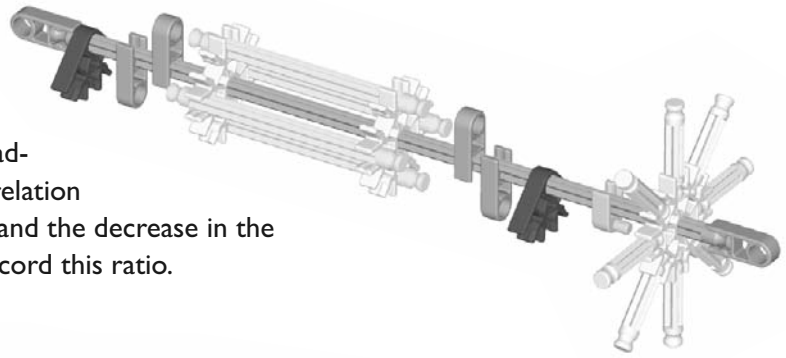

Combination 5 reinforces the idea that a wheel and axle works in the same fashion as a lever. They will find the force measurements to be the same as Combination 4 since the circumference of the wheel has not changed. Students can attach longer Rods to the white Connector and predict the affect it will have on the force based on their prior observations and calculations.

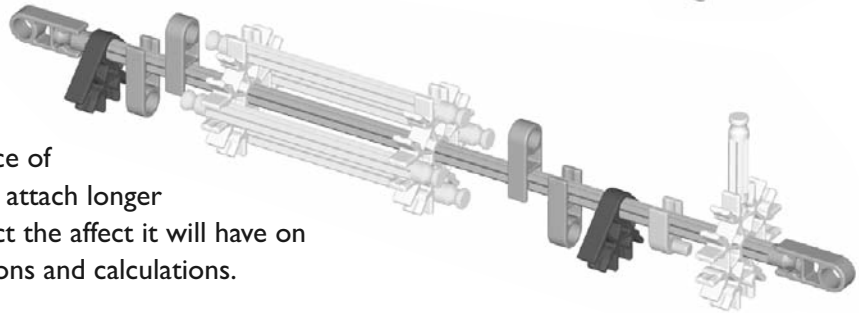

Combination 6 dramatically reveals the reason for using a wheel that is larger than the axle to increase the amount of force. It will be so difficult to turn this wheel that the students will likely decide to just turn the axle to lift the bucket.

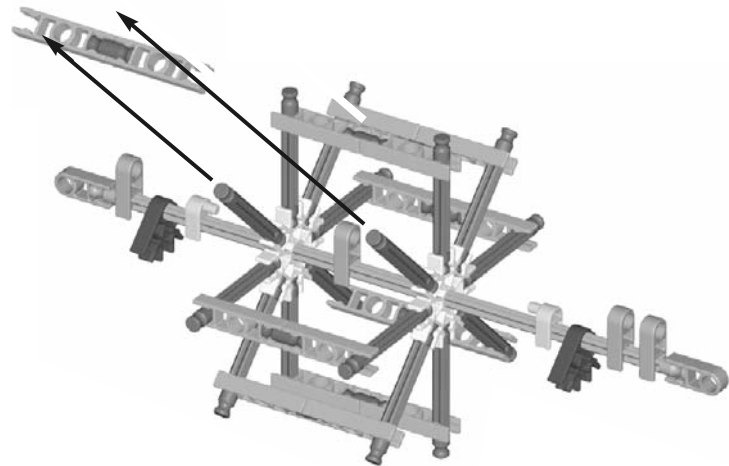

Student Challenge

Determine the Mechanical Advantage of each wheel and axle combination. (Use the “What’s the Mechanical Advantage” Reference Sheet for help.) Based on the MA of each wheel and axle combination, which one makes it easiest to do the job of lifting the bucket? Is this the same combination that made lifting easiest

according to your force measurements? If not, what may be the reason that they don’t agree? [Students should find that Combination 1 offers the greatest MA. This is because it has the largest effort radius divided by the smallest resistance radius.]

The Wishing Well

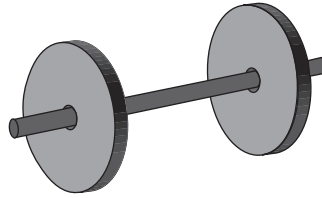

Every wheel and axle has a job to do

Where's the wheel on a wishing well? Look at the parts that turn - at the top of the well. The rope winds around the axle and the handle or crank you turn is the wheel. You can pull a bucket full of water up from the bottom of the well using this wheel and axle. This simple machine makes lifting the bucket much easier than just hauling up the rope by hand.

How does the Wishing Well help you?

Put your Wishing Well to work.

- Did you turn the wheel to make the axle go around? If so, your machine helps you do a job with more Force.
- Or did you turn the axle to make the wheel go around? If so, your machine helps you cover more Distance at a faster speed.

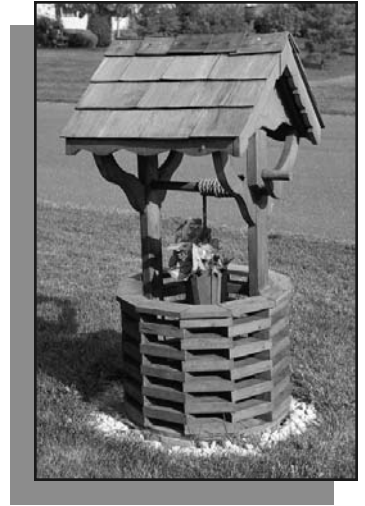

Student Challenge

- 1 Build and place your Wishing Well on two desks set several centimeters apart so the bucket hangs down between them. Place a cup filled with small weights (like pennies, green Rods, etc.) in the bucket. Attach the K'NEX Rubber Band Scale to the bucket. Measure and record the force needed to lift this weight.
- 2 For each wheel and axle combination (1–6), build the model and attach it to your Wishing Well. Experiment and test each one and answer these questions.
 - a. Which part is the wheel and which is the axle? (Note: Sometimes the wheel is not easily identified.)
 - b. Each time the wheel makes one complete turn, the bucket is raised a short way. Use a measuring tape to measure the distance around the axle and the outside edge of the wheel. Compare the two measurements. How many times do you have to turn the wheel to raise the bucket

to the top? Compare this to how many times the axle is turned. What does this tell you about the way the Wishing Well works?

c. Attach the K'NEX Rubber Band Scale to the axle and measure the force used to lift the bucket. Then, measure the force with the Scale attached to the wheel. Record your measurements.

d. Based on the amount of force used, did this wheel and axle make lifting the bucket harder or easier than lifting the bucket by itself? Why?

e. Which wheel and axle makes lifting the bucket easiest? Compare the measurements from the Rubber Band Scale. Why was this combination so helpful?

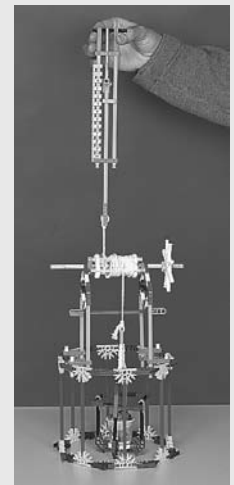

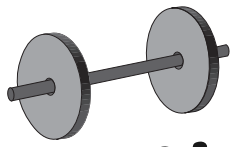

Wrench Lesson Plan

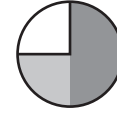

Lesson Length: 30-45 minutes

Objectives

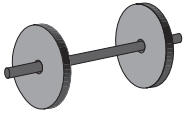

- Identify the wheel and axle on a wrench
- Demonstrate how a wrench functions as a wheel and axle
- Determine if a wrench helps do a job with more force or more distance and speed
- Experiment to determine how the size of the Wrench and nut affect function
- Practice creative design
- Investigate the uses of various types of wrenches

Materials

- a piece of large drawing paper
- extra K'NEX pieces

Every wheel and axle has a job to do

You can see wrenches in use as you watch a car race, such as the Indy 500. Each racer has a pit crew that has to change tires and make repairs in a hurry—every second counts! They use special wrenches to help them work fast. At school or at home, ask students to try out a few examples of real wrenches. Tell them to handle and twist them to get a feel for how a wrench and bolt operate as a wheel and axle.

How does the Wrench help you?

Turning the wheel part of the Wrench (the handle) provides you with more force, which can be used to loosen or tighten bolts.

Journal Check

- ✓ Explanation of how a wrench is like a wheel
- ✓ Explanation of how work changes when changing the size of the nut or Wrench
- ✓ Description of jobs performed by special wrenches

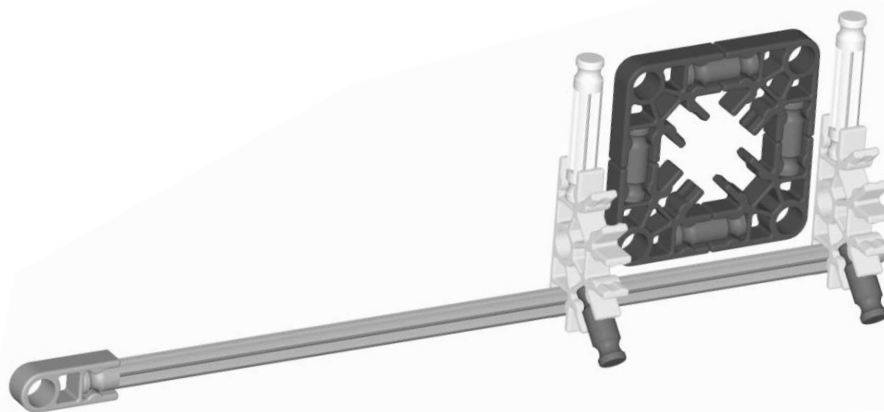

QUESTIONS

- 1 How is a wrench like a wheel? To find out, put your K'NEX nut in the middle of a big piece of paper. Place one finger in the middle of the nut to hold it in place.

Then, grip the nut with your Wrench. Poke a pencil point through the gray Connector at the end of the Wrench's handle and turn the Wrench. As you turn, let the pencil draw on the paper. What shape does the pencil draw?

- 2 Would turning a nut be easier or harder if you make the nut bigger? Explain how the work would change if you keep the nut the same size but make the wrench longer? (Use the "What's the Mechanical Advantage?" Reference Sheet.)
- 3 Look at the different kinds of wrenches in the picture below. Which one is most like your K'NEX Wrench? Make other K'NEX wrenches that match the ones in the picture. You might also try to make some K'NEX nuts to go with them.
- 4 Do research to find out what special job each wrench does.



ANSWERS

- 1 The pencil line traces out a circle. This example illustrates how the Wrench is a wheel.
- 2 Increasing the size of the nut (axle) will make the job harder. Increasing the length of the Wrench (wheel) will make the job easier. The greater the difference in size between the axle and the wheel, the easier the wheel is to turn.
- 3 The K'NEX Wrench is like a plumber's monkey wrench because they are both adjustable with smooth, square jaws.
- 4 Share the following information with students if they have trouble finding it on their own:
 - a. Hydrant Wrench-** Firemen use this wrench to open fire hydrants.
 - b. Socket Wrench-** Auto mechanics use these wrenches which come in a set with sockets of different sizes.
 - c. Crescent Wrench-** People use this for common household jobs. It's adjustable to fit nuts and bolts of many sizes.
 - d. Pipe Wrench-** Plumbers use this wrench for gripping and turning pipes; it has teeth on its jaws to grip the pipe.
 - e. Open-end Wrench-** This is good for turning nuts that you can only get at from the side.
 - f. Box Wrench-** This fits over the top of a nut or bolt to get a good grip.

The Wrench

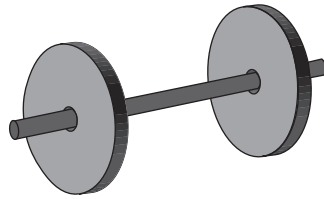

Every wheel and axle has a job to do

The wrench gets a grip on the head of a bolt and when you give the wrench a turn, it tightens or loosens the bolt. A wrench doesn't look like a wheel, but it turns in a circle. The bolt acts as the axle and the place where you hold the wrench is the rim of the wheel.

How does the Wrench help you?

Put your Wrench to work.

- Did you turn the wheel to make the axle go around? If so, your machine helps you do a job with more Force.
- Or did you turn the axle to make the wheel go around? If so, your machine helps you cover more Distance at a faster speed.

Student Challenge

- 1 How is a wrench like a wheel? To find out, put your K'NEX nut in the middle of a big piece of paper. Place one finger in the middle of the nut to hold it in place. Then, grip the nut with your Wrench. Poke a pencil point through the gray Connector at the end of the Wrench's handle and turn the Wrench. As you turn, let the pencil draw on the paper. What shape does the pencil draw?
- 2 Would turning a nut be easier or harder if you make the nut bigger? Explain how the work would change if you keep the nut the same size but make the wrench longer? (Use the "What's the Mechanical Advantage?" Reference Sheet.)
- 3 Look at the different kinds of wrenches in the picture below. Which one is most like your K'NEX Wrench? Make other K'NEX wrenches that match the ones in the picture. You might also try to make some K'NEX nuts to go with them.
- 4 Do research to find out what special job each wrench does.



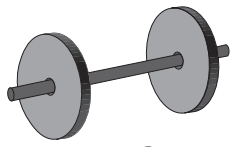

Screwdriver Lesson Plan

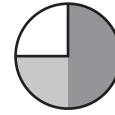

Lesson Length: 30-45 minutes

Objectives

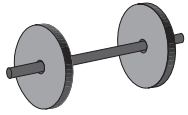

- Identify the wheel and axle on a screwdriver
- Demonstrate how a screwdriver functions as a wheel and axle
- Determine if a screwdriver helps do a job with more force or more distance and speed
- Investigate the uses of various types of screwdrivers
- Practice creative design
- Explain the purpose of the screwdriver based on investigation
- Infer usefulness of a screwdriver

Materials

- a few wood screws
- screwdriver
- scraps of wood with holes drilled into them
- extra K'NEX pieces

Every wheel and axle has a job to do

This diagram reinforces the concept that the wheel turns a greater distance in one turn than the axle turns, but the axle turns with more force, compared to the wheel. This extra force helps twist the screw into the wood. (Make illustrations available to students.)

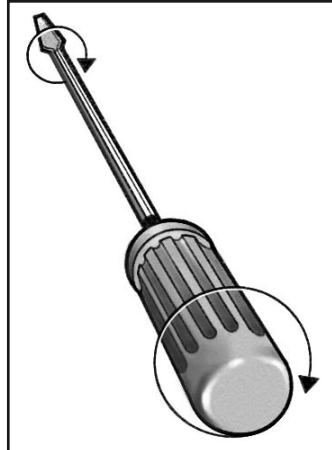

How does the Screwdriver help you?

Since you turn the wheel, the Screwdriver helps by providing more force, which you can use to twist screws or bolts into place in any kind of material.

Journal Check

- ✓ Identification of which screw goes with which screwdriver
- ✓ Descriptive differences between twisting a screw with and without a screwdriver
- ✓ Explanation of how the screwdriver is a useful tool

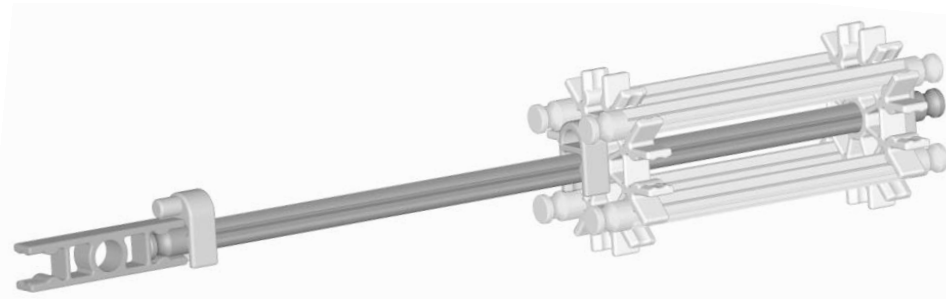

QUESTIONS

- 1** a. You may have seen screwdrivers with different tips to fit different screws or bolts. Some tips are straight lines, some have a cross shape and others form a six-sided box. Each has a different name, such as Phillips, hex and slot. Which screwdriver goes with which screw in the picture?



- b. Imagine that a white Connector is the head of a screw. Make a new tip for your K'NEX Screwdriver so that it can turn the white Connector.
- 2** How could you change your K'NEX Screwdriver to make its axle turn with more force? Try building a super-powered K'NEX screwdriver.
- 3** Try twisting a real screw into a hole in a block of wood just using your hand. Then, drive in the screw using a real screwdriver. Write a few sentences to describe the difference between your two tries and how a screwdriver is helpful.
- 4** Is the screwdriver a useful tool? How many screws and bolts can you find in your classroom? Look around, count them and determine how many screwdrivers with different tips you would need for all of these screws.

ANSWERS

- 1** To make a new Screwdriver tip, students could snap a tan Connector on the end of the gray Rod, with its peg pointing down. This tip can fit into any Connector and turn without slipping.
- 2** Students should alter their Screwdrivers to make the diameter of the handle bigger. This change makes the wheel bigger and able to deliver more force to the axle. Note that making the Screwdriver longer will not change the amount of its force.
- 3** Students will probably say that driving in the screw by hand was very hard or impossible, but with the help of the screwdriver, it was much easier. They should also explain that the screwdriver's handle acts as a wheel and the tip is the axle. Turning the wheel makes the axle turn with more force.
- 4** Encourage students to look all over the classroom for screws and bolts - in desks, chairs, tables, bookshelves, windows, doors and doorways, computers, chalkboards, even eyeglasses! The many examples they find should convince them that screwdrivers are useful tools.

The Screwdriver

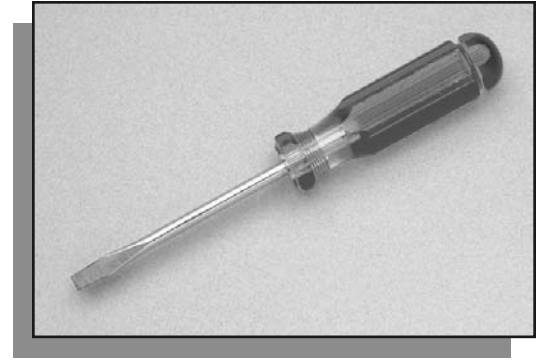
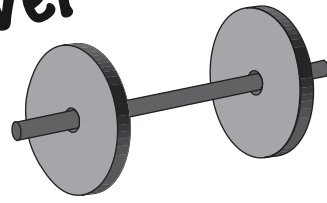

Every wheel and axle has a job to do

Look down on the top of a screwdriver and you'll see that it is round, like a wheel. The handle gives you a good grip for turning. It acts as the wheel and the screwdriver's tip is the axle. Together they can drive a screw into a piece of wood.

How does the Screwdriver help you?

Put your Screwdriver to work.

- Did you turn the wheel to make the axle go around? If so, your machine helps you do a job with more Force.
- Or did you turn the axle to make the wheel go around? If so, your machine helps you cover more Distance at a faster speed.

Student Challenge

- 1 a. You may have seen screwdrivers with different tips to fit different screws or bolts. Some tips are straight lines, some have a cross shape and others form a six-sided box. Each has a different name, such as Phillips, hex and slot. Which screwdriver goes with which screw in the picture?



b. Imagine that a white Connector is the head of a screw. Make a new tip for your K'NEX Screwdriver so that it can turn the white Connector.

- 2 How could you change your K'NEX Screwdriver to make its axle turn with more force? Try building a super-powered K'NEX screwdriver.
- 3 Try twisting a real screw into a hole in a block of wood just using your hand. Then, drive in the screw using a real screwdriver. Write a few sentences to describe the difference between your two tries and how a screwdriver is helpful.
- 4 Is the screwdriver a useful tool? How many screws and bolts can you find in your classroom? Look around, count them and determine how many screwdrivers with different tips you would need for all of these screws.

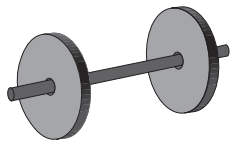

Ferris Wheel Lesson Plan

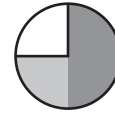

Lesson Length: 30-45 minutes

Objectives

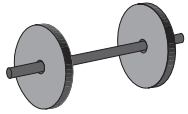

- Identify the wheel and axle on a Ferris wheel
- Demonstrate how a Ferris wheel functions as a wheel and axle
- Determine if a Ferris wheel helps do a job with more force or more distance and speed
- Measure and compare distances traveled by the wheel and axle
- Modify the Ferris Wheel to increase performance
- Practice creative design
- Investigate the history of the original Ferris wheel and identify statistics

Materials

- tape measure
- string
- ruler
- extra K'NEX pieces

Every wheel and axle has a job to do

Riding a ferris wheel gives you a bird's-eye view of the world from above the treetops. It can do this by using a powerful motor to turn the axle and drive the huge wheel.

How does the Ferris Wheel help you?

Turning the axle makes the Ferris Wheel turn and cover more distance, giving riders a huge lift.

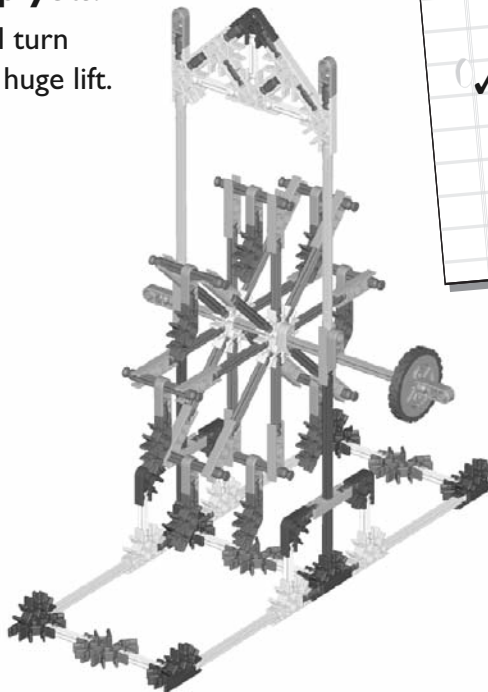

Journal Check

- ✓ Distance measurements of wheel and axle
- ✓ Explanation of how to make the axle easier to turn
- ✓ Early history and factual information about the original Ferris wheel

QUESTIONS

- Give your Ferris Wheel a spin and watch how it turns. How far does the axle move in one turn? Using a tape measure or a string and a ruler, measure the distance around the axle to find out. Then, measure the distance around the wheel's rim to find out how far the wheel moves in one turn.
 - You can see that a little turn of the axle makes the wheel turn a long way. But to do this, the axle must turn with great force. The smaller the axle, the more force it needs. How can you change your Ferris Wheel to make it easier to turn the axle?
- Try making another kind of K'NEX carnival ride that uses a big wheel. You might make a carousel or a double Ferris wheel that turns its passengers upside down! Be creative.
- Check your library to find out the history of the Ferris wheel and where/how it got its name.
Determine how big the original Ferris wheel was, how many people it could carry and where it was located.

ANSWERS

- To measure the circumference of the wheel and the axle, students might use a tape measure or wrap a piece of string around the wheel and axle and measure each length of the string. They should find that the axle's circumference is about 2 cm, and the wheel's is about 58 cm.
 - To make the axle easier to turn, students might suggest adding a crank to the axle. The crank serves as a wheel to turn the axle, so it can turn the axle with less force. Note that a real Ferris wheel uses gears (a special kind of wheel) and a powerful motor to turn the axle.
- When students build other carnival rides, have them point out the wheel and axle in each ride and compare the distance the wheel and axle each have to travel. Suggest they use the K'NEX Motor to run the rides, like in a real amusement park.
- The original Ferris wheel was the creation of George Washington Gale Ferris, a bridge builder. He built it to be a star attraction of Chicago's Columbian Exposition of 1893. The wheel was about 76 meters across and it had 36 cars. Each car could carry 40 riders, so a total of 1,440 people could ride the Ferris wheel at once. It was built like a bicycle wheel with steel spokes. The wheel needed this kind of lightweight framework or it would have been too heavy to turn.
The Ferris wheel was not the first of its kind; smaller versions called "pleasure wheels" had been around for years. The Ferris wheel, however, was so impressive that it made these rides more popular, and people have called them Ferris wheels ever since.

The Ferris Wheel

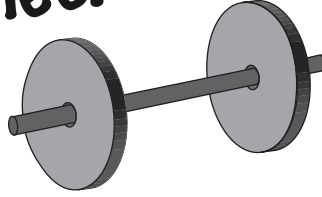

Every wheel and axle has a job to do

As you glide through the air on a Ferris wheel you might not think that a wheel and axle are at work, but they are. A powerful motor turns the sturdy axle of this simple (but big!) machine. The wheel itself is large and turns in a big circle - the bigger the better! The larger the wheel, the higher you'll be, and the farther you'll see.

How does a Ferris Wheel help you?

Put your Ferris Wheel to work.

- Did you turn the wheel to make the axle go around? If so, your machine helps you do a job with more Force.
- Or did you turn the axle to make the wheel go around? If so, your machine helps you cover more Distance at a faster speed.

Student Challenge

- Give your Ferris Wheel a spin and watch how it turns. How far does the axle move in one turn? Using a tape measure or a string and a ruler, measure the distance around the axle to find out. Then, measure the distance around the wheel's rim to find out how far the wheel moves in one turn.
 - You can see that a little turn of the axle makes the wheel turn a long way. But to do this, the axle must turn with great force. The smaller the axle, the more force it needs. How can you change your Ferris Wheel to make it easier to turn the axle?
- Try making another kind of K'NEX carnival ride that uses a big wheel. You might make a carousel or a double Ferris wheel that turns its passengers upside down! Be creative.
- Check your library to find out the history of the Ferris wheel and where/how it got its name. Determine how big the original Ferris wheel was, how many people it could carry and where it was located.

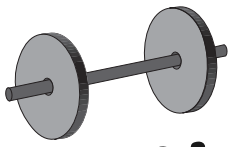

Water Wheel Lesson Plan

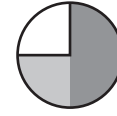

Lesson Length: 30-45 minutes

Objectives

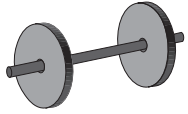

- Identify the wheel and axle on a water wheel
- Demonstrate how a water wheel functions as a wheel and axle
- Determine if a water wheel helps do a job with more force or more distance and speed
- Investigate how water provides the effort to the Water Wheel
- Design and describe an imaginative function of the Water Wheel
- Modify the Water Wheel so that it can perform a task
- Demonstrate what the Water Wheel can do
- Practice creative design
- Research turbines and determine their function

Materials

- foil or plastic wrap (8 pieces @ 10 cm x 15 cm)
- water
- sink (bucket or laundry tub)
- towels for water spills
- scissors

Every wheel and axle has a job to do

Real water wheels work in several different ways. They might use water that runs from the side (breast wheel), over the top (overshot wheel) or under the wheel (undershot wheel).

Note that the overshot wheel can run with a weaker flow of water, because it uses gravity to pull down the water in the paddles. An undershot wheel requires a swiftly flowing stream.

How does the Water Wheel help you?

Water turns the Water Wheel, making the axle turn with more force. This force can be used to power other machines.

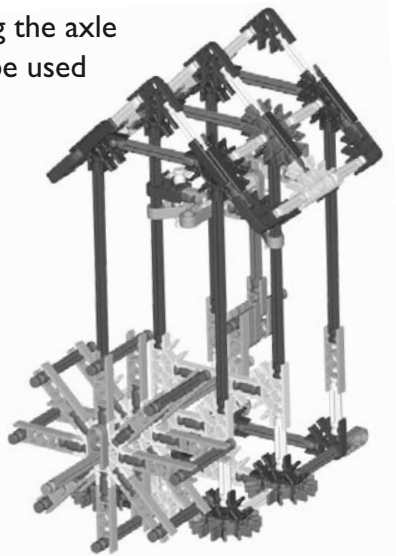

Journal Check

- ✓ Observations of the Water Wheel in use
- ✓ Creative description of how the Water Wheel could function as a piece of business equipment
- ✓ Explanation of work performed by modified Water Wheel
- ✓ Research information about turbines

QUESTIONS

- 1** a. As a real water wheel turns, each paddle catches some water. Use foil or plastic wrap to make paddles on your K'NEX Water Wheel. Make sure each paddle has a rim, like the edge of a tray, to hold the water on the paddle.

b. Try out your Water Wheel under running water. Hold the wheel under a faucet and let the water run over the paddles along one side of the wheel.



- 2** What happens inside the Water Wheel's house when the wheel turns? Turn the wheel and observe. How can this machine be used to do work? Imagine that this machine is a piece of equipment that your business owns. Write a brief description of what this machine can do.
- 3** Now try making your Water Wheel do some work. You might attach a string to the axle and tie a weight to the other end of the string. Turning the wheel should lift the weight. Or you might have the Water Wheel turn a pinwheel or spin a colorful disk to see how the colors blend. Show your classmates your invention.
- 4** Find out about another kind of water wheel, e.g. turbines in dams. What job do they do?

ANSWERS

- 1** To make foil paddles, students can fold a 10 cm x 15 cm piece of foil or plastic wrap around each blade of the Water Wheel, crimping up the edges to make a rim.
- 2** The platform inside the Water Wheel's house goes up and down as the wheel is turned. Students' answers will vary as to how the machine can be used to do work. They should write a clear descriptive paragraph of what type of business they own and how the machine is used in this business by the job it does.
- 3** When planning ways to put their Water Wheels to work, students should think of machines they know that have moving or turning parts, such as a fan, pencil sharpener, wagon, eggbeater, etc. They can also investigate real machines that were powered by water wheels: stone wheels for grinding different types of grain, circular saws at a lumber mill, trip hammers and bellows in a blacksmith shop and machinery in early factories.
- 4** Turbines are a kind of water wheel used in conjunction with dams. Most dams don't just hold back the flow of water. They let the water build up so that it can be channeled with greater pressure and with a steady stream to run the turbines. The turbines then run generators that produce electricity.

The Water Wheel

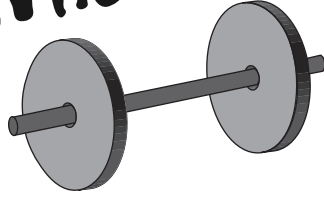

Every wheel and axle has a job to do

Before people used electricity to run machines, they used water wheels. The running water in a stream made the big wheel and its axle turn. Inside the building, the other end of the axle might turn a grinding wheel or a saw. As long as the water kept flowing, all kinds of work could get done!

How does a Water Wheel help you?

Put your Water Wheel to work.

- Did you turn the wheel to make the axle go around? If so, your machine helps you do a job with more Force.
- Or did you turn the axle to make the wheel go around? If so, your machine helps you cover more Distance at a faster speed.

Student Challenge

- 1 a. As a real water wheel turns, each paddle catches some water. Use foil or plastic



wrap to make paddles on your K'NEX Water Wheel. Make sure each paddle has a rim, like the edge of a tray, to hold the water on the paddle.

b. Try out your Water Wheel under running water. Hold the wheel under a faucet and let the water run over the paddles along one side of the wheel.

- 2 What happens inside the Water Wheel's house when the wheel turns? Turn the

wheel and observe. How can this machine be used to do work? Imagine that this machine is a piece of equipment that your business owns. Write a brief description of what this machine can do.

- 3 Now try making your Water Wheel do some work. You might attach a string to the axle and tie a weight to the other end of the string. Turning the wheel should lift the weight. Or you might have the Water Wheel turn a pinwheel or spin a colorful disk to see how the colors blend. Show your classmates your invention.
- 4 Find out about another kind of water wheel, e.g. turbines in dams. What job do they do?

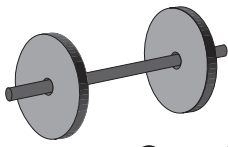

Paddlewheel Boat Lesson Plan

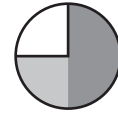

Lesson Length: 30-45 minutes

Objectives

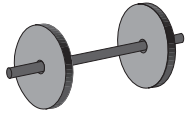

- Identify the wheel and axle on a paddlewheel boat
- Demonstrate how the paddlewheel on a boat functions as a wheel and axle
- Determine if a paddlewheel boat helps do a job with more force or more distance and speed
- Compare and contrast the design and function of a paddlewheel and water wheel
- Investigate how the effort is provided to the Paddlewheel Boat
- Research the history of paddlewheel boats
- Practice creative design

Materials

- plastic wrap or foil
- 2 small blocks of wood
- heavy duty rubber bands
- water
- large tub or sink

Journal Check

- ✓ Comparison of design and function of paddlewheel and water wheel
- ✓ Explanation of why paddlewheel boats are used on calm waters, based on deductions and observations
- ✓ Comparison of paddlewheel functioning with and without blade covering
- ✓ History of various paddlewheel boats

Every wheel and axle has a job to do

Paddlewheel boats of the past used steam engines to turn their wheels. The engines would have been noisy and hot. These boats traveled at a slow and steady pace. They were more reliable than boats with sails, because they didn't have to depend on the changeable winds.

How does the Paddlewheel Boat help you?

An engine, in this case a Rubber Band, turns the axle, which makes the wheel cover more distance, paddling through the water to make the Paddlewheel Boat go.

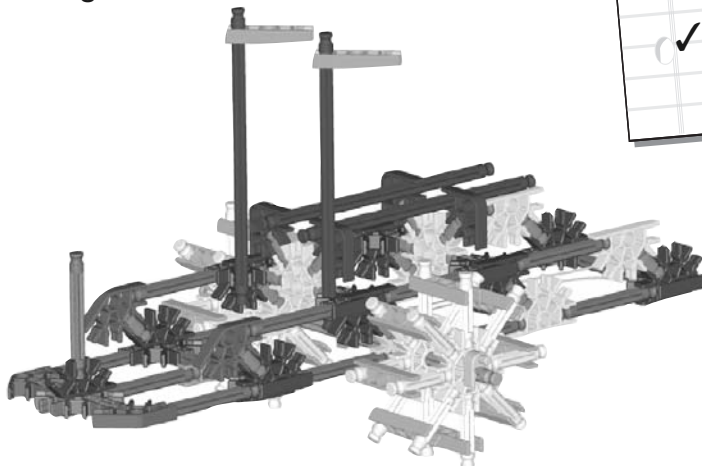

QUESTIONS

- 1 Compare the design and function of the paddlewheel and water wheel. How are the wheels alike and different? (*Hint: Refer to the pictures and models on the Paddlewheel Boat and Water Wheel Activity Sheets.*) One has a wheel that turns the axle and one has an axle that turns a wheel. Which is which?
- 2 Wrap the blades of the wheel with foil or plastic wrap to make paddles that will push against water. Then, use rubber bands to attach a block of wood (for buoyancy) to each end of your boat.

Wind up the “rubber band motor” on the paddlewheel and run your Paddlewheel Boat in a large tub. Watch how the wheel and axle work. Why is a paddlewheel boat used mostly on calm waters? Compare the function of the paddlewheels with and without covered blades. Report your findings.

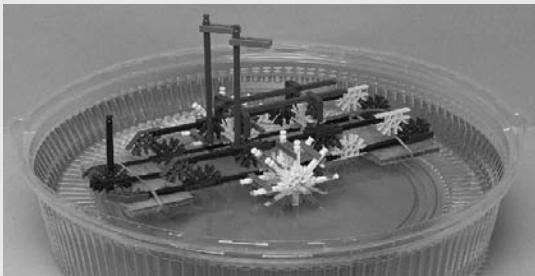

- 3 Research various paddlewheel boats and their histories. Using K'NEX, build one of these paddlewheel boats and present it to the class.

⚠ Safety Note: BE CAREFUL NOT TO OVERSTRETCH THE RUBBER BAND. Stretching can cause the Rubber Band to snap and cause injury. If you notice any deterioration of your Rubber Band, notify your teacher immediately.

ANSWERS

- 1 In comparing the paddlewheel and the water wheel, students might note that they both have numerous paddles or troughs to catch water. The water wheel is attached to a building, while the paddlewheel moves along with a boat. Water provides the force to turn the water wheel, while a motor turns the axle of the paddlewheel boat. In the water wheel, the wheel makes the axle turn, while the paddlewheel works in the opposite way - the axle turns the wheel.
- 2 Provide students with as large a sink as possible to float their boats. If you can work outside, you might construct a “canal” by building a narrow rectangle of bricks, covering it with a large plastic garbage bag and filling the interior space with water. Students should see that the Rubber Band motor on their boats provides the power to turn the axle. The wheel turns a great distance, sweeping through the water and making the Paddlewheel Boat move.
- 3 Students answers will vary. Most likely they will obtain information about and build the Clermont which was an early steam-powered paddlewheel boat built by Robert Fulton. It was launched in 1807, sailing up the Hudson River from New York City to Albany. The Clermont was not the first steamboat, but it was the first to be a business success. It was important because it showed that steamboats could travel faster and more reliably than sailing ships. After the Clermont, steamboats became more popular. The use of steamboats encouraged travel, trade and the westward settlement in the United States.

The Paddlewheel Boat

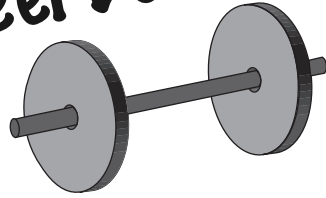

Every wheel and axle has a job to do

A paddlewheel boat splashes water as it travels calm rivers and lakes. Its engine turns an axle, which turns the big wheel. As the wheel turns, it pushes against the water, like oars do, propelling the boat forward.

How does a Paddlewheel Boat help you?

Put your Paddlewheel Boat to work.

- Did you turn the wheel to make the axle go around? If so, your machine helps you do a job with more Force.
- Or did you turn the axle to make the wheel go around? If so, your machine helps you cover more Distance at a faster speed.

Student Challenge

- 1 Compare the design and function of the paddlewheel and water wheel. How are the wheels alike and different? (*Hint: Refer to the pictures and models on the Paddlewheel Boat and Water Wheel Activity Sheets.*) One has a wheel that turns the axle and one has an axle that turns a wheel. Which is which?
- 2 Wrap the blades of the wheel with foil or plastic wrap to make paddles that will push against water. Then, use rubber bands to attach a block of wood (for buoyancy) to each end of your boat. Wind up the “rubber band motor” on the paddlewheel and run your Paddlewheel Boat in a large tub. Watch how the wheel

and axle work. Why is a paddlewheel boat used mostly on calm waters? Compare the function of the paddlewheels with and without covered blades. Report your findings.



- 3 Research various paddlewheel boats and their histories. Using K'NEX, build one of these paddlewheel boats and present it to the class.

⚠ Safety Note: BE CAREFUL NOT TO OVERSTRETCH THE RUBBER BAND. Stretching can cause the Rubber Band to snap and cause injury. If you notice any deterioration of your Rubber Band, notify your teacher immediately.

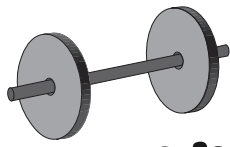

Windmill Lesson Plan

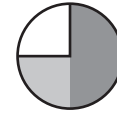

Lesson Length: 30-45 minutes

Objectives

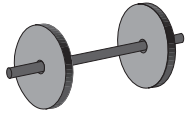

- Understand how a windmill functions as a wheel and axle
- Determine if a windmill helps do a job with more force or more distance and speed
- Identify the wheel and axle on the Windmill
- Manipulate the Windmill to determine its best working conditions
- Compare and contrast function of a windmill and water wheel
- Modify the Windmill so it can perform a task
- Explain the function of the modified Windmill

Materials

- paper or cardboard
- scissors
- tape
- electric fan or blow dryer (optional)
- extra K'NEX pieces

Warning: *Important note:*

Be extremely careful whenever using electrical devices. Teachers should monitor student activities at all times, and should examine devices before use.

Every wheel and axle has a job to do

Windmills are often found on farms or in other open spaces. Students should use reference materials to find out how people have used windmills. For example, they might research the use of windmills in the Netherlands, the American west or how they are still used today in Amish country.

How does the Windmill help you?

Wind turns the wheel of the Windmill, providing more force for running other machines off the axle.

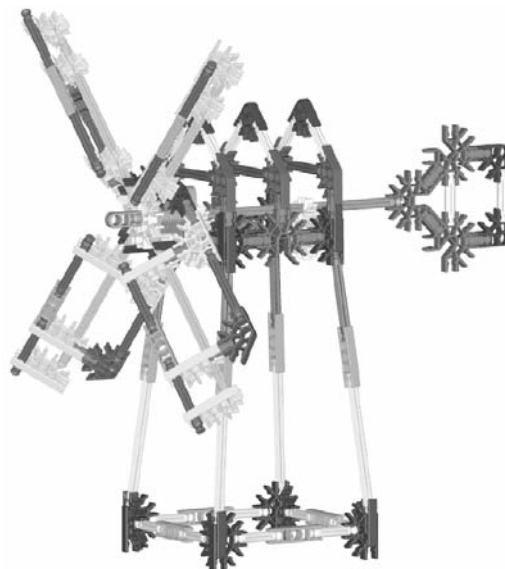

Journal Check

- ✓ Results of testing Windmill under various wind conditions
- ✓ List of possible jobs for windmills
- ✓ Comparison of functions of windmill and water wheel
- ✓ Descriptive paragraph about functions of modified Windmill

QUESTIONS

- 1**
 - a. Make paper sails for your Windmill, and tape them to the Windmill's blades. Each blade should tilt in like the blades of a pinwheel.
 - b. Take your Windmill outside and let the wind turn the blades. Test the Windmill in different spots around the schoolyard. Can you tell from your Windmill which place is the windiest? How?
 - c. Place your Windmill in a windy spot and face it in different directions. Which direction makes the Windmill turn fastest? Does it spin when faced in all directions? Discuss your findings.
- 2** What useful job could your Windmill do? Windmills can do some of the same jobs that water wheels do. Compare how the two kinds of wheels can do the same job. *(Hint: See the Water Wheel Activity Sheet.)*
- 3** Alter your Windmill so that you can use it to do a job, like making a see-saw move up and down. Write a descriptive paragraph explaining what your windmill can do and how it performs this task.

ANSWERS

- 1**
 - a. Students might tape paper or cardboard shapes like triangles or rectangles onto the K'NEX Rods to serve as sails for their Windmills. They should look at pictures of real windmills to give them ideas.
 - b. Use an electric fan or blow dryer to turn students' Windmills if it isn't convenient to go outside.
Ask students to test their Windmills and find a spot which is the windiest. People who build windmills also have to find the windiest spots to locate their windmills. Often a windmill is placed high on a hill or on a tower to catch the wind. Up high the wind isn't blocked by buildings, trees, or hills.
 - c. The Windmill will turn fastest in the direction that the wind strikes it at a 90° angle. Real windmills can be turned to face in the best direction so they can be used whenever there is enough wind, no matter the direction from which it comes.
- 2** To compare the K'NEX Water Wheel and Windmill, students might try attaching a weight on a string to each axle and letting the axle wind up the string to lift the weight. The two wheels differ in their diameter, so they will have different Mechanical Advantages. They will also differ in the amount of force that turns the wheel.
- 3** The paragraphs should include an explanation of the job the new Windmill is designed to do, the alterations that were made and how the Windmill performs its task.

The Windmill

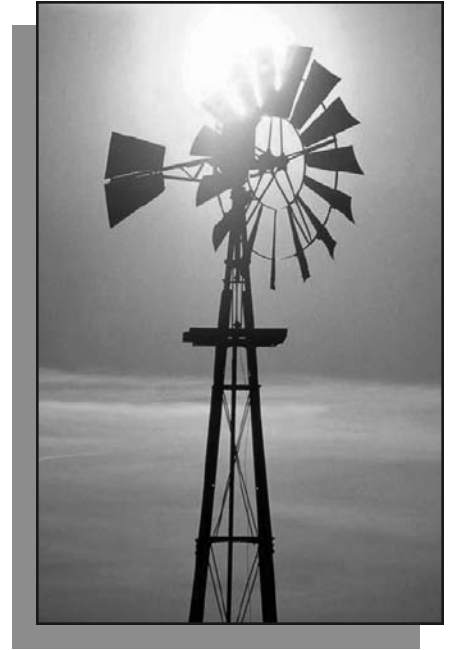
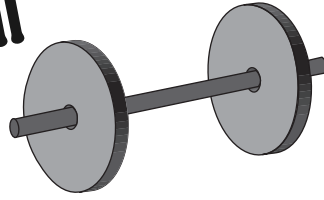

Every wheel and axle has a job to do

The wind does the job of turning a windmill's big wheel. The wheel makes the axle turn with great force. If you connect the axle to some other machine, you can make the wind work for you! People use windmills to produce electricity, run water pumps and grind grain into flour.

How does the Windmill help you?

Put your Windmill to work.

- Did you turn the wheel to make the axle go around? If so, your machine helps you do a job with more Force.
- Or did you turn the axle to make the wheel go around? If so, your machine helps you cover more Distance at a faster speed.

Student Challenge

- Make paper sails for your Windmill, and tape them to the Windmill's blades. Each blade should tilt in like the blades of a pinwheel.
 - Take your Windmill outside and let the wind turn the blades. Test the Windmill in different spots around the schoolyard. Can you tell from your Windmill which place is the windiest? How?
 - Place your Windmill in a windy spot and face it in different directions. Which direction makes the Windmill turn fastest? Does it spin when faced in all directions? Discuss your findings.
- What useful job could your Windmill do? Windmills can do some of the same jobs that water wheels do. Compare how the two kinds of wheels can do the same job. (*Hint: See the Water Wheel Activity Sheet.*)
- Alter your Windmill so that you can use it to do a job, like making a see-saw move up and down. Write a descriptive paragraph explaining what your windmill can do and how it performs this task.

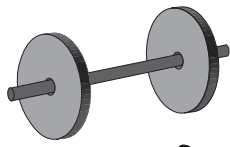

Measuring Wheel Lesson Plan

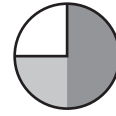

Lesson Length: 30-45 minutes

Objectives

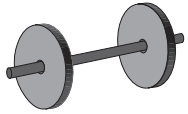

- Identify the wheel and axle on a measuring wheel
- Determine how a measuring wheel helps do a job
- Measure the circumference of the Measuring Wheel
- Measure and compute distances with the Measuring Wheel and determine the relationship with map scale
- Evaluate the usefulness of a measuring wheel in different situations

Materials

- chalk
- measuring tape or meterstick
- street map with scale
- highway map with scale
- bicycle wheel, hula hoop or other large wheel

Every wheel and axle has a job to do

Students should think of situations where a measuring wheel might be useful. Surveyors, road building crews and landscapers all use measuring wheels to measure distances. Policemen also use them to help determine the circumstances which actually occurred in a car accident. There are other tools that have a similar shape as the measuring wheel such as pizza cutters, paint rollers, tracing wheels or pie crust crimpers. Each of these tools uses a wheel to do a job over a certain distance.

How does a Measuring Wheel help you?

The Measuring Wheel is not an example of a wheel and axle system. It doesn't provide more force or more distance, as wheels and axles do, but it does make a job easier. Instead of repeatedly lifting and placing a measuring stick or tape to take a measurement, you just roll the measuring wheel along. In this way, the wheel reduces your work and makes it less difficult to do the job.

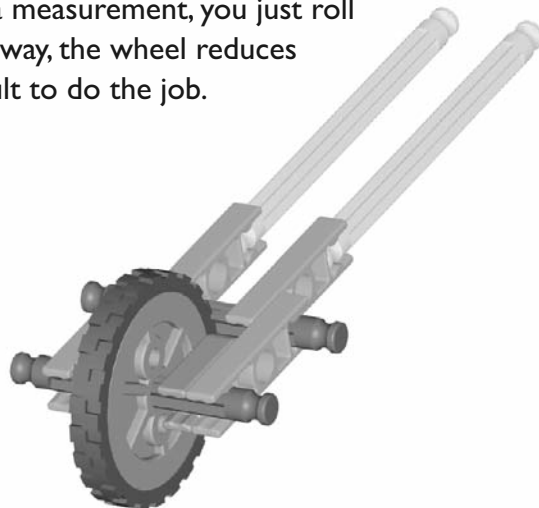

Journal Check

- ✓ Circumference of Measuring Wheel
- ✓ Calculated distance measurements for classroom
- ✓ Explanation of why the Measuring Wheel is better than a ruler or meterstick for certain tasks
- ✓ Measurements for locations on a map based on map's scale

QUESTIONS

- 1 a. Make a mark with chalk at any point along the rim of your Measuring Wheel. This mark will make it easier for you to count the turns your Measuring Wheel makes.
 
 - b. Measure the distance around the outside edge of your Measuring Wheel (its circumference) and record your measurement.
 - c. Now, use your Measuring Wheel to measure a distance in your classroom. Run your Wheel along the path you chose and count the number of turns the Wheel makes. Then, multiply that number by the Wheel's circumference to get your distance measurement. [Distance = Number of turns x Circumference]
- 2 Draw a squiggly line on the chalkboard. Then, run your Measuring Wheel along the line to measure its length. Why is a Measuring Wheel better than a ruler for this job?
- 3 Choose two locations on a map. Challenge your partner to use the Measuring Wheel to find the shortest distance between the two places. Make sure your partner follows the roads and highways on the map. Then switch and let your partner test your measuring skills.
- 4 Try using a bigger wheel, such as a bike wheel or hula hoop, to measure the distance across your school yard. Then measure the distance using a meterstick. Compare your results. Why is the wheel a good measuring tool for this job?

ANSWERS

- 1 Students should work in pairs, with one student running the Measuring Wheel and one counting the turns. They might measure the distance from their desks to the chalkboard or the length of the chalkboard. Encourage students to compare measurements to see how accurate they can be.
- 2 Students should find that using the wheel to measure along a squiggly line is much easier than using a ruler because the wheel can conform to the line.
- 3 Students should calculate the distances based on the scale of the map. One turn of the Measuring Wheel might measure five centimeters and represent one mile.
- 4 Any large wheel would work as a measuring wheel for long distances. Students can try different methods (such as pacing or using a meterstick) and time how long each method takes. Using a wheel will likely be the quickest method.

The Measuring Wheel

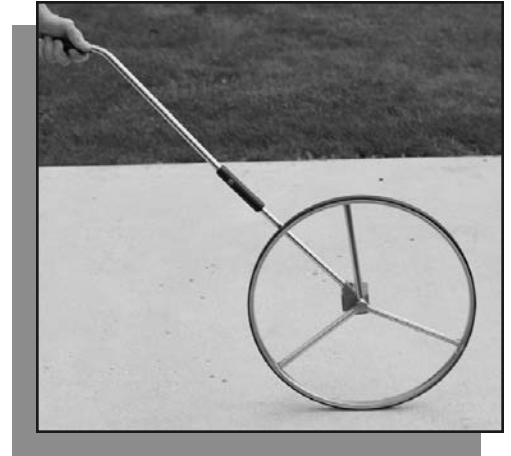
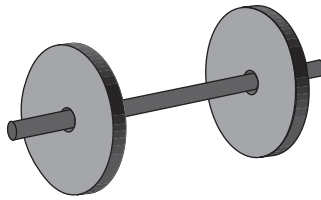

Every wheel and axle has a job to do

It's easy to measure a short distance with a ruler or meterstick. But you'd need a super-long measuring tape to find the length of a baseball field. Using a measuring wheel is much easier. You just roll the wheel along and count how many turns it makes. The number of turns times the distance around the wheel (circumference) tells you the total length. A measuring wheel is also great for measuring the length of a crooked path.

How does a Measuring Wheel help you?

Put your Measuring Wheel to work.

- Did you turn the wheel to make the axle go around? If so, your machine helps you do a job with more Force.
- Or did you turn the axle to make the wheel go around? If so, your machine helps you cover more Distance at a faster speed.

Student Challenge

- 1 a. Make a mark with chalk at any point along the rim of your Measuring Wheel. This mark will make it easier for you to count the turns your Measuring Wheel makes.



- b. Measure the distance around the outside edge of your Measuring Wheel (its circumference) and record your measurement.
- c. Now, use your Measuring Wheel to measure a distance in your classroom. Run your Wheel along the path you chose and count the number of turns the Wheel makes. Then, multiply that number by the Wheel's circumference to get your distance measurement.

[Distance = Number of turns x Circumference]

- 2 Draw a squiggly line on the chalkboard. Then, run your Measuring Wheel along the line to measure its length. Why is a Measuring Wheel better than a ruler for this job?
- 3 Choose two locations on a map. Challenge your partner to use the Measuring Wheel to find the shortest distance between the two places. Make sure your partner follows the roads and highways on the map. Then switch and let your partner test your measuring skills.
- 4 Try using a bigger wheel, such as a bike wheel or hula hoop, to measure the distance across your school yard. Then measure the distance using a meterstick. Compare your results. Why is the wheel a good measuring tool for this job?

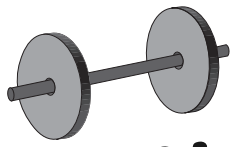

Wagon Lesson Plan

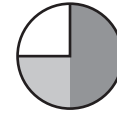

Lesson Length: 30-45 minutes

Objectives

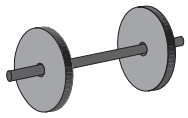

- Identify the wheel and axle on a wagon
- Identify how the wheels and axles on the Wagon function
- Demonstrate how a wagon helps do a job by reducing friction
- Measure and compare forces applied to move the Wagon with and without wheels
- Observe effects on friction when comparing force measurements
- Determine if the number of wheels affects the friction force
- Investigate the history of the wheel in relation to vehicles
- Practice creative design
- Draw pictures of wheeled vehicles and describe their purposes

Materials

- box of books or other weights
- K'NEX Rubber Band Scale
- extra K'NEX pieces including Hubs and Tires

Every wheel and axle has a job to do

In the Middle East at least 5,000 years ago, people began using wheels to move heavy loads. People moved huge stones by rolling them on logs that they laid on the ground. The logs had to be repeatedly moved in front of the stone as it rolled along. Even then, people realized that it was easier to roll something along than it was to push or pull it.

How does the Wagon help you?

The Wagon uses its wheels in a different way than other wheel and axle machines, such as a windmill or paddlewheel boat. The Wagon's wheels can spin freely because they are not attached to their axles. The Wagon's wheels simply make moving across a surface easier by reducing friction. The Wagon does not offer a Mechanical Advantage.

Journal Check

- ✓ Comparison between ease of pulling the Wagon with and without wheels
- ✓ Force measurements for pulling the Wagon with four and eight wheels and without wheels
- ✓ Force measurements for pulling the box versus the Wagon
- ✓ Explanation and comparison of force measurements for different tests
- ✓ Pictures of wheeled vehicles and description of their purpose

QUESTIONS

- 1 a. Build your Wagon without wheels so it works like a sled. Load a box with books and rest it on your Wagon. Pull the Wagon on a smooth floor. Is it hard or easy to move the load? Add the wheels to the Wagon and pull it. What do you notice?
- b. Build the K'NEX Rubber Band Scale and connect it to the front end of your Wagon.
- c. Measure how much force it takes to move the Wagon and its load with and without its wheels. Record and compare your results. What do they show?

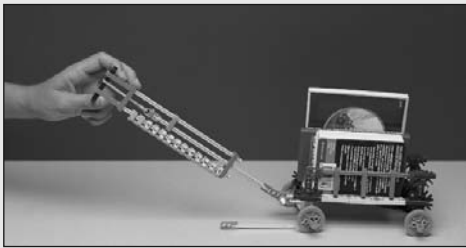

- d. Connect the Scale's string to the box. Place the Wagon on top of the box. How much force is used to drag the box across a smooth floor? Are you still pulling the same amount? Are you using the same amount of force? If not, how and why is it different?
- 2 Rebuild your Wagon with eight wheels instead of four. Measure how much force it takes to pull this Wagon. More or less than before? Why?
- 3 Learn about the history of wheels and different types of vehicles which use them. Using K'NEX, build some of these historic wheeled models.
- 4 Draw pictures of some wheeled vehicles and write a description telling where they would be most useful and why.

ANSWERS

- 1 a. Students need to adjust the load so the force reading falls in the middle of the Scale. Students should find it easier to pull the Wagon with wheels attached.
 - b. The force measurements should reflect a significant difference and confirm the answer to question 1a. Dragging the Wagon creates a lot of friction, while rolling it on wheels greatly reduces friction. The Wagon makes work easier by reducing friction.
 - c. To make a fair comparison between dragging the load and moving it on wheels, both loads must be the same weight. That's why students must include the Wagon with the box when they drag the load. Otherwise, they would be changing two variables, which would confuse the results.

Students might compare how much force is needed to pull the Wagon over different surfaces of the same length, including polished wood, coarse sandpaper and carpet. This will further demonstrate the effects of friction.
- 2 This answer will vary depending on the placement of the extra wheels. If the extra wheels are placed on separate axles that are distributed throughout the length of the Wagon, the students are not likely to discern any difference in the force measurements.

However, if they double up the wheels on the existing axles, they will notice that it takes significantly more force to pull the Wagon. The reason for this is that doubling up the tires on the same axle creates a wheel with double the surface area on the axle, thereby creating more friction as this large wheel rubs against the surface. Lead students to experiment with the wheels in both configurations.
- 3 Fat wheels are needed to hold up heavy vehicles and to run on rough, soft or slippery ground. Big trucks, tractors and planes have fat wheels. Narrow wheels are good for lightweight, speedy vehicles on roads or even ground. Bicycles and horse carriages have narrow wheels.

The Wagon

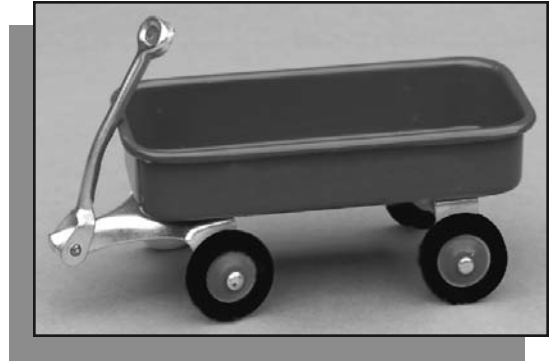
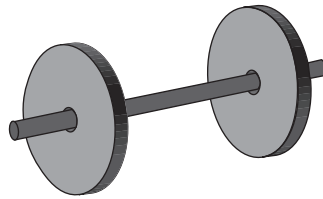

Every wheel and axle has a job to do

Before wheels were invented, people dragged heavy loads along the ground or pulled them on simple sleds. Then wheels got things rolling! People use wheels for wagons and carts, carriages and cars, trains and even planes. Wheels make moving things easier because wheels can move with less friction (the rubbing of one surface against another).

How does the Wagon help you?

Put your Wagon to work.

- Did you turn the wheel to make the wagon go around? If so, your machine helps you do a job with more Force.
- Or did you turn the axle to make the wheel go around? If so, your machine helps you cover more Distance at a faster speed.

Student Challenge

- Build your Wagon without wheels so it works like a sled. Load a box with books and rest it on your Wagon. Pull the Wagon on a smooth floor. Is it hard or easy to move the load? Add the wheels to the Wagon and pull it. What do you notice?
 - Build the K'NEX Rubber Band Scale and connect it to the front end of your Wagon.
 - Measure how much force it takes to move the Wagon and its load with and without its wheels. Record and compare your results. What do they show?
 - Connect the Scale's string to the box. Place the Wagon on top of the box. How
- Rebuild your Wagon with eight wheels instead of four. Measure how much force it takes to pull this Wagon. More or less than before? Why?
- Learn about the history of wheels and different types of vehicles which use them. Using K'NEX, build some of these historic wheeled models.
- Draw pictures of some wheeled vehicles and write a description telling where they would be most useful and why.

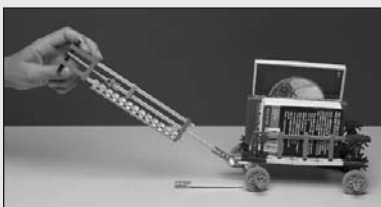

much force is used to drag the box across a smooth floor? Are you still pulling the same

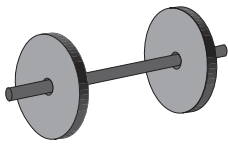

Carousel Lesson Plan

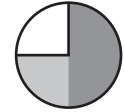

Lesson Length: 30-45 minutes

Objectives

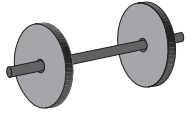

- Identify the wheels and axles on a carousel
- Demonstrate how a carousel functions as a wheel and axle
- Determine if a carousel does a job with more force or more distance and speed
- Predict effects of wheel size on the Carousel's functioning
- Understand the concept of wheel radius and its effects on wheel function
- Compare and contrast other amusement park rides to the Carousel
- Modify the Carousel to increase turning speed
- Practice creative design
- Investigate and describe other machines that function similarly to the Carousel

Materials

-extra K'NEX pieces

Every wheel and axle has a job to do

The center of a carousel is usually enclosed behind painted panels or canvases. This is where the working machinery of the carousel is housed. The panels may include a door for the carousel operator go through to run the machinery. The working parts of the K'NEX Carousel differ from those in a real carousel, but both types include a combination of wheels and axles which make the carousel run.

How does the Carousel help you?

The Carousel includes several wheels and axles:

- the crank acts as a wheel to turn the horizontal axle with more force
- this axle makes a small wheel turn, covering a good distance with each turn of the axle; the wheel covers more distance than the axle would alone
- the small wheel rubs against the white Connector, using friction to make the platform spin; the rim of the wheel provides just enough friction to move the platform, without grinding surfaces together

(The other small wheel, located on the far end of the axle, just helps balance the platform; it doesn't make the platform turn.)

- the platform acts as a wheel that spins freely on its axle; this wheel is useful because it moves through a large distance, providing a long ride at an enjoyable speed.

Journal Check

- ✓ Explanation of how the Carousel's crank acts like a wheel
- ✓ Prediction of how the Carousel would behave if the friction wheel was changed
- ✓ Explanation of radius and its relationship to the performance of the Carousel
- ✓ Plans/drawings for modifying the Carousel to make it run faster
- ✓ Comparison between carousels and other spinning amusement park rides
- ✓ Descriptive paragraph about the work performed by everyday machines that are similar to the Carousel

QUESTIONS

- 1 Turn the crank to make your Carousel spin. Then, try spinning the Carousel by turning the axle attached to the crank. Which way is easier? Explain how the crank works like a wheel.
- 2 Watch how the horizontal gray axle makes the small wheel under the Carousel turn. This wheel uses friction to grip the white Connector on the Carousel platform and make the Carousel turn.

How many times does the Carousel turn for every turn of the small Wheel? How would your Carousel turn differently if this wheel was larger? How about if it was smaller?
- 3 Imagine you're riding on one of the horses on the Carousel platform. The platform acts as a big wheel that carries you around in a circle.

A radius has something to do with a circle. Find out what a radius is and how it relates to wheels. How would your ride be different if the radius of this circle (the platform wheel) was larger or smaller?
- 4 What other amusement park rides spin their riders in a circle? How are they different from the carousel? How would you change the K'NEX Carousel to make it a faster ride? Draw and build your new design.
- 5 Conduct an investigation to determine what everyday machines work similarly to the Carousel. In a short paragraph, describe the work they do.

ANSWERS

- 1 Use the Carousel as a culminating activity for your study of wheels and axles. This model includes several wheels which work in different ways, allowing students to review what they have learned throughout the unit.
- 2 Students should find that turning the crank is easier than turning the axle itself, because the wheel gives you a greater Mechanical Advantage. (See the "What's the Mechanical Advantage?" Reference Sheet.) The increase in Mechanical Advantage is due to the fact that the effort radius is larger when you use the crank. (The radius of the crank is larger than the radius of the axle.)

The Carousel

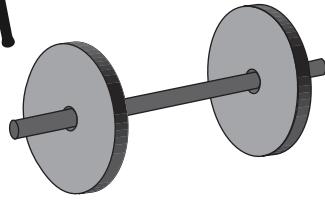

Every wheel and axle has a job to do

When you're going round and round on a carousel, the only thing on your mind is enjoying the ride. But did you know a carousel is a machine that uses lots of wheels and axles? The carousel platform is one big wheel, but many other wheels make up the machinery that makes the carousel turn.

How does the Carousel help you?

Put your Carousel to work.

- Did you turn a wheel to make the axle go around? If so, your machine helps you do a job with more Force.
- Or did you turn an axle to make the wheel go around? If so, your machine helps you cover more Distance at a faster speed.

Student Challenge

- 1 Turn the crank to make your Carousel spin. Then, try spinning the Carousel by turning the axle attached to the crank. Which way is easier? Explain how the crank works like a wheel.
- 2 Watch how the horizontal gray axle makes the small wheel under the Carousel turn. This wheel uses friction to grip the white Connector on the Carousel platform and make the Carousel turn.
How many times does the Carousel turn for every turn of the small Wheel? How would your Carousel turn differently if this wheel was larger? How about if it was smaller?
- 3 Imagine you're riding on one of the horses on the Carousel platform. The platform acts as a big wheel that carries you around in a circle.
A radius has something to do with a circle. Find out what a radius is and how it relates to wheels. How would your ride be different if the radius of this circle (the platform wheel) was larger or smaller?
- 4 What other amusement park rides spin their riders in a circle? How are they different from the carousel? How would you change the K'NEX Carousel to make it a faster ride? Draw and build your new design.
- 5 Conduct an investigation to determine what everyday machines work similarly to the Carousel. In a short paragraph, describe the work they do.

WHEELS & AXLES Part & Model List

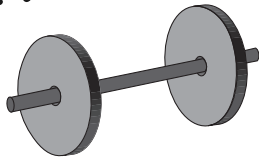

	SPINNING TOP	WISHING WELL	WRENCH	SCREWDRIVER	FERRIS WHEEL	WATER WHEEL	PADDLEWHEEL BOAT	WINDMILL	MEASURING WHEEL	WAGON	CAROUSEL	TOTAL PARTS IN WHEEL & AXLE
Tan Connector	0	2	0	3	3	2	4	0	0	0	2	18
Gray Connector	0	11	1	0	13	12	2	5	2	13	15	20
Orange Connector	4	26	0	1	20	21	18	13	4	7	18	31
Red Connector	4	8	4	0	5	13	4	9	0	2	7	17
Green Connector	0	18	0	0	8	0	4	10	0	0	12	18
Yellow Connector	0	16	2	0	9	10	8	16	0	8	15	16
Blue Connector	0	0	0	0	3	6	1	5	0	2	7	7
White Connector	1	5	0	2	2	2	4	3	0	0	3	6
Purple Connector	0	8	0	0	12	14	17	16	0	10	15	17
Green Rod	4	47	6	0	24	34	18	30	0	20	38	47
White Rod	4	22	2	0	13	28	32	18	0	8	22	34
Blue Rod	4	26	0	0	24	16	18	19	2	7	18	33
Yellow Rod	0	4	0	4	4	1	0	4	2	1	5	5
Red Rod	0	9	0	0	2	6	4	0	0	3	5	9
Gray Rod	0	1	1	1	1	1	1	1	0	0	1	4
Gold Rod	0	4	0	0	2	0	0	4	0	0	4	4
Sm. Tire	0	1	0	0	1	0	0	0	1	0	2	2
Sm. Pulley	0	1	0	0	1	0	0	0	1	4	2	4
Top Spindle	1	0	0	0	0	0	0	0	0	0	0	1
Rubber Band #18	0	0	0	0	0	0	1	0	0	0	0	3
Cord	0	1	0	0	0	0	0	0	0	0	0	1
TOTALS FOR MODELS	22	210	16	11	147	166	136	153	12	85	191	297