

# KNEX®

# Education™

## TEACHER'S GUIDE

SIMPLE MACHINES DELUXE™  
LEVERS

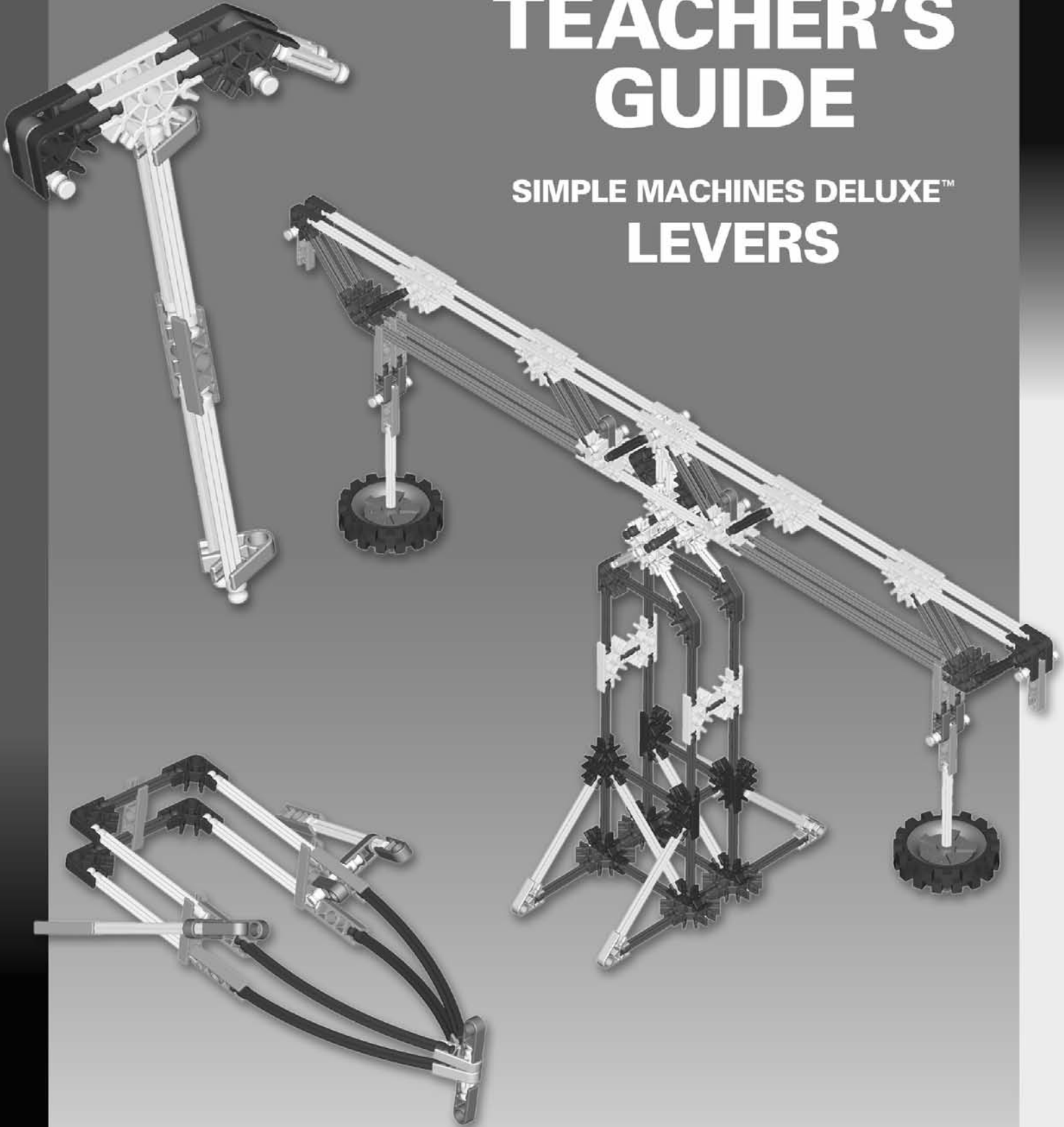

# TEACHER'S GUIDE

## SIMPLE MACHINES DELUXE™ LEVERS

KNX 79520-V1-11/10  
©2011 K'NEX Limited Partnership Group  
and its licensors.

K'NEX is a trademark of K'NEX Limited Partnership Group.

Website: [www.knexeducation.com](http://www.knexeducation.com)  
Email: [abcknex@knex.com](mailto:abcknex@knex.com)  
Phone: 1-888-ABC-KNEX (USA/CAN only)

K'NEX Limited Partnership Group  
P.O. Box 700  
Hatfield, PA 19440-0700  
USA



### **WARNING:**

CHOKING HAZARD - Small parts.  
Not for children under 3 years.



### **AVERTISSEMENT :**

DANGER D'ÉTOUFFEMENT - Pièces de petite taille.  
Ne convient pas aux enfants de moins de 3 ans.



# Table of Contents

<b>Simple Machines Deluxe Introduction</b> .....	4
<b>Standard Alignments</b> .....	5
<b>All About Levers</b>	
What is a Lever? .....	8
Key Words and Definitions .....	8
Key Concepts .....	9
<b>Student Reference Sheets</b> .....	10
<b>Balance</b>	
Lesson Plan .....	16
Student Activity Sheet .....	20
<b>See-Saw</b>	
Lesson Plan .....	21
Student Activity Sheet .....	23
<b>Catapult</b>	
Lesson Plan .....	24
Student Activity Sheet .....	26
<b>Handcart</b>	
Lesson Plan .....	27
Student Activity Sheet .....	29
<b>Rowboat</b>	
Lesson Plan .....	30
Student Activity Sheet .....	32
<b>Scissors</b>	
Lesson Plan .....	33
Student Activity Sheet .....	35
<b>Door</b>	
Lesson Plan .....	36
Student Activity Sheet .....	38
<b>Wheelbarrow</b>	
Lesson Plan .....	39
Student Activity Sheet .....	41
<b>Fishing Rod</b>	
Lesson Plan .....	42
Student Activity Sheet .....	44
<b>Hammer</b>	
Lesson Plan .....	45
Student Activity Sheet .....	47
<b>Tweezers</b>	
Lesson Plan .....	48
Student Activity Sheet .....	50
<b>Lever Mobile</b>	
Lesson Plan .....	51
Student Activity Sheet .....	53
<b>Rubber Band Scale</b> .....	54
<b>Part &amp; Model List</b> .....	56

# Introduction:

## OVERVIEW

This Teacher's Guide has been developed to support you as your students investigate the K'NEX Education Simple Machines Deluxe Set. In conjunction with the K'NEX materials and individual student journals, the information and resources here can be used to build your students' understanding of scientific concepts and channel their inquiries into active and meaningful learning experiences.

## SIMPLE MACHINES DELUXE

This K'NEX Education set is designed to introduce students to the scientific concepts associated with simple machines. Students are provided with the opportunity to acquire skills using a hands-on, inquiry based approach to information and concepts. Working cooperatively, students are encouraged to interact with each other as they build, investigate, discuss and evaluate scientific principles in action.

## TEACHER'S GUIDE

Designed as a resource for the teacher, this guide provides a glossary of key terms and definitions, includes an overview of the concepts associated with the different simple machines, identifies student objectives for each investigation, and offers plans and scripts to successfully present selected models and their associated activities. We have also provided Student Activity and Reference Sheets. These comprise illustrations and definitions of some of the concepts featured in the model building activities. Most lessons can be completed in 30 to 45 minutes. We recommend that teachers review their curriculum and science education standards to identify those activities that best support their academic needs.

## STUDENT JOURNALS

It is expected that students will have journals available for recording information. They should be encouraged to enter initial thought at the start of an inquiry – what they “think” will happen. These initial thoughts may be amended, based upon their ongoing inquiry and analysis, until the students feel comfortable about drawing conclusions. Their journal entries will help make a connection between the models they have built, the experiments they have conducted, and how this information is applied to the real-world machines they use on a regular basis. The journals will also provide students with a place to practice making drawings and diagrams of systems. Finally, the journals will serve as a method of assessment for the Simple Machines units. Journal Checklists are also included in the Teacher's Guide for each model and its associated activities.

## Alignment with National Standards Grades K-4

### The National Science Education Standards

<b>Unifying Concepts and Processes</b>	<ul style="list-style-type: none"><li>• Systems, order, and organization</li><li>• Evidence, models, and explanation</li><li>• Change, constancy, and measurement</li><li>• Form and function</li></ul>
<b>Physical Science</b>	<ul style="list-style-type: none"><li>• Properties of objects and materials</li><li>• Position and motion of objects</li></ul>
<b>Science and Technology</b>	<ul style="list-style-type: none"><li>• Abilities of technological design</li><li>• Understandings about science and technology</li></ul>

Reprinted with permission from National Science Education Standards, 2001 by the National Academy of Sciences, Courtesy of the National Academies Press, Washington, D.C.

## Alignment with National Standards Grades 5 - 8

### The National Science Education Standards

<b>Unifying Concepts and Processes</b>	<ul style="list-style-type: none"><li>• Systems, order, and organization</li><li>• Evidence, models, and explanation</li><li>• Change, constancy, and measurement</li><li>• Form and function</li></ul>
<b>Physical Science</b>	<ul style="list-style-type: none"><li>• Motions and Forces</li><li>• Transfer of Energy</li></ul>
<b>Science as Inquiry</b>	<ul style="list-style-type: none"><li>• Abilities necessary to do scientific inquiry</li><li>• Understanding about scientific inquiry</li></ul>
<b>Science and Technology</b>	<ul style="list-style-type: none"><li>• Abilities of technological design</li><li>• Understandings about science and technology</li></ul>

Reprinted with permission from National Science Education Standards, 2001 by the National Academy of Sciences, Courtesy of the National Academies Press, Washington, D.C.

# Alignment with Standards for Technological Literacy Grades 3-5

<b>Standards for Technological Literacy</b>	
<p><b>The Nature of Technology</b></p>	<p>Core Concepts of Technology</p> <ul style="list-style-type: none"> <li>• Systems</li> <li>• Processes</li> <li>• Requirements</li> </ul> <p>Relationships among technologies</p> <ul style="list-style-type: none"> <li>• Technologies integrated</li> </ul>
<p><b>Design</b></p>	<p>The Attributes of design</p> <ul style="list-style-type: none"> <li>• Requirements of design</li> </ul> <p>Engineering Design</p> <ul style="list-style-type: none"> <li>• Engineering design process</li> <li>• Creativity and considering all ideas</li> <li>• Models</li> </ul> <p>The role of troubleshooting, research and development, invention and innovation, and experimentation in problem solving</p> <ul style="list-style-type: none"> <li>• Troubleshooting</li> <li>• Invention and innovation</li> <li>• Experimentation</li> </ul>
<p><b>Abilities of a Technological World</b></p>	<p>Apply design process</p> <ul style="list-style-type: none"> <li>• Collecting information</li> <li>• Visualize a solution</li> <li>• Test and evaluate solutions</li> <li>• Improve a design</li> </ul>

Used with permission of ITEEA ([www.iteea.org](http://www.iteea.org))

# Alignment with Standards for Technological Literacy Grades 6 - 8

## Standards for Technological Literacy

<p><b>The Nature of Technology</b></p>	<p>Core Concepts of Technology</p> <ul style="list-style-type: none"> <li>• Systems</li> <li>• Processes</li> <li>• Requirements</li> </ul> <p>Relationships among technologies</p> <ul style="list-style-type: none"> <li>• Interaction of systems</li> <li>• Knowledge from other fields of study and technology</li> </ul>
<p><b>Design</b></p>	<p>The Attributes of design</p> <ul style="list-style-type: none"> <li>• Design leads to useful products and systems</li> <li>• There is no perfect design</li> </ul> <p>Engineering Design</p> <ul style="list-style-type: none"> <li>• Brainstorming</li> <li>• Modeling, testing, evaluating, and modifying</li> </ul> <p>The role of troubleshooting, research and development, invention and innovation, and experimentation in problem solving</p> <ul style="list-style-type: none"> <li>• Troubleshooting</li> <li>• Invention and innovation</li> <li>• Experimentation</li> </ul>
<p><b>Abilities of a Technological World</b></p>	<p>Apply design process</p> <ul style="list-style-type: none"> <li>• Identify criteria and constraints</li> <li>• Test and evaluate</li> <li>• Make a product or system</li> </ul>

Used with permission of ITEEA ([www.iteea.org](http://www.iteea.org))

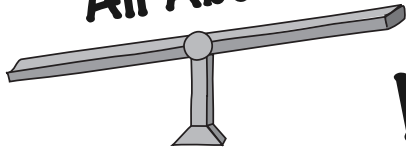

## What is a Lever?

- A lever is a stiff bar often made of metal, plastic or wood.
- The lever pivots on one point, the fulcrum—up, down or side-to side—to produce the motion that helps do work.
- To use a lever, you provide effort and the lever helps you work against the resistance.
- Levers can change the amount of force needed to do work, the direction of the applied forces and the work that is produced.

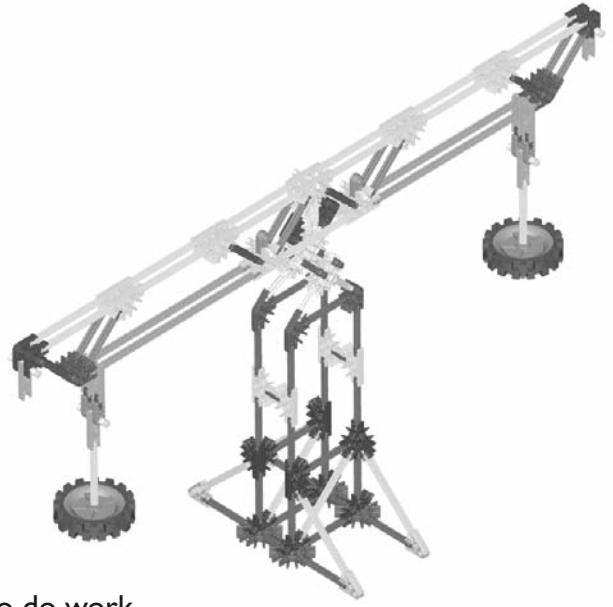

## Key Words and Definitions

**Effort** - the force that is applied to do work; the push, pull, squeeze or lift provided to use a lever on an object

**Effort Arm (EA)** - distance on the lever from the fulcrum to the point where the effort is applied

**Resistance** - the force provided by the object on which one is trying to do work; the object works against (pushes back) the effort

**Resistance Arm (RA)** - distance on the lever from the fulcrum to the point where the resistance is applied

**Fulcrum** - the spot along the lever that sits still as the rest of the bar rotates or pivots around it

**Mechanical Advantage (MA)** - a mathematical calculation that reveals how many times easier a job is to do when a lever is used;  $EA \div RA = MA$

**Work** - the job being done while using the lever

**Load** - the object (weight) lifted or moved; provides resistance to the lever

**Force** - any kind of push or pull applied to an object

**Double lever** - two levers attached to each other at the fulcrum; might be a pair of 1st, 2nd or 3rd-class levers; work together to do one job

# Key Concepts

## How do levers help you?

- Levers make work easier by reducing the amount of force needed to do a job.
- Some levers also change the direction of the work that is being done.

## What is a 1st-class lever?

- 1st-class levers have the fulcrum in the middle.
- The effort and resistance are at opposite ends of the lever.
- The effort and the resistance move in opposite directions—push down on the lever and the load lifts up.
- If the resistance is close to the fulcrum, work is easy.
- If the effort is close to the fulcrum, work is hard.

## What is a 2nd-class lever?

- 2nd-class levers have the resistance in the middle.
- The fulcrum and effort are at opposite ends.
- The effort and the resistance move in the same direction—lift up the lever and the load also goes up.
- 2nd-class levers always make work easier; they increase the force applied because the effort is always further from the fulcrum than the resistance.

## What is a 3rd-class lever?

- 3rd-class levers have the effort in the middle.
- The fulcrum and resistance are at opposite ends.
- The effort and the resistance move in the same direction—lift up the lever and the load also goes up.
- 3rd-class levers make work harder; they reduce the force applied because the effort arm is always shorter than the resistance arm.
- 3rd-class levers can be helpful since they allow the resistance to move a further distance or at a faster rate than without the lever.

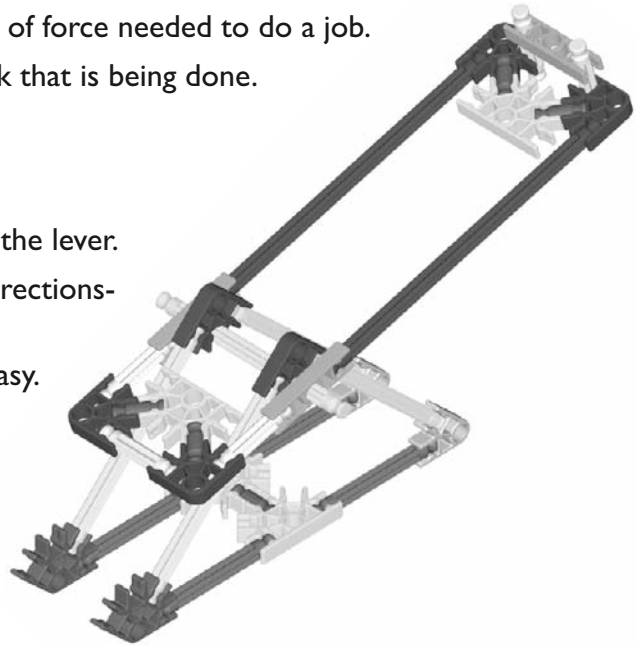

# REMEMBER

**When the resistance is closer to the fulcrum than the effort, the work is easier.**

**When the effort is closer to the fulcrum than the resistance, the work is harder.**

# Getting Started with Levers

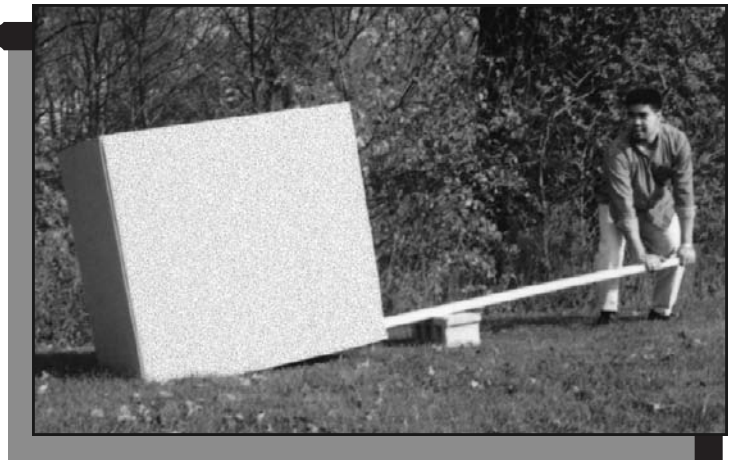
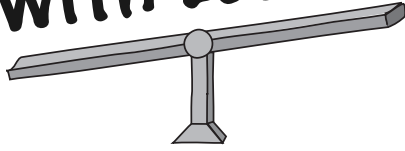

## What is a lever?

- It's a stiff bar, often made of metal, plastic or wood.
- When you use a lever, you move the bar up and down or side to side.
- To use a lever, you provide the **effort**. The effort might be a push, pull, squeeze or lift.
- The lever might help you lift a weight, cut some paper or crack a nut. These objects provide **resistance**. The object resists, or works against, your effort. You push one way and the resistance pushes back against you.
- The **fulcrum** is the spot on the bar that is still as the rest of the bar rotates around it.
- Levers come in many shapes and sizes, but they all help do work.

## How does a lever help you?

A lever is a simple machine that can make work easier. You still have to do the same *amount* of work, but with a lever, you need less force to do the job.

## Here's an example of how levers can help.

Imagine trying to lift an elephant, and then hold it five centimeters off the floor. Five centimeters isn't much but an elephant is HEAVY! Sounds impossible, but not if you have a lever!

## Picture this.

Place a lever under the elephant. When you push down on one end of the lever, up goes the elephant on the other side. You have to reach up high and push down a *long* way—much farther than the five centimeters the elephant is lifted. But the lever is pretty easy to push down. The lever makes work easier since you need to use *less force*, but you have to use that force over a *greater distance*.

**Increasing the distance between the effort and the fulcrum reduces the effort needed.**

## A Bright Idea!

Archimedes was a scientist and mathematician who lived in Greece more than 2,000 years ago. He was the first known person to describe how levers work using math. Learn more about Archimedes and his famous statement about levers. Would his idea work? Why or why not?



# What's the Mechanical Advantage?



## How much does a lever help you?

Find out by doing a little math.

- 1 Measure the distance from the **fulcrum** to the **effort**. This length is called the **effort arm (EA)**.
- 2 Measure the distance from the **fulcrum** to the **resistance**. This distance is called the **resistance arm (RA)**.
- 3 Divide the length of the effort arm by the length of the resistance arm to find the **Mechanical Advantage (MA)**.

$$MA = EA \div RA$$

The Mechanical Advantage tells you how many times easier your job is when you use the lever.



## Student Challenge

### Imagine you are using a lever to lift a box.

The effort arm of your lever is six meters long (EA = 6). The resistance arm is two meters long (RA = 2).

Divide to get the Mechanical Advantage.

$$MA = 6 \div 2$$

$$MA = 3$$

The Mechanical Advantage is 3, which means that this lever makes your job three times easier. Without the lever, you would need three times as much force to lift the box.

### Remember:

When the effort arm is longer than the resistance arm, there will be a Mechanical Advantage. The longer the effort arm, the greater the Mechanical Advantage.

# What is a 1st-class lever



A **1st-class lever** has the **FULCRUM** in the **middle**. The **Resistance** and **Effort** are at opposite ends.



## Here's an example.

Imagine you're a circus clown, ready to jump down on a springboard to launch an acrobat into the air. The effort is the force provided when you jump and push down on the end of the board. The acrobat is the resistance since she is the weight you are trying to lift. The fulcrum is in the middle.

## Which way does a 1st-class lever move?

When you **push down** on the board, the acrobat will **go up**. All 1st-class levers are like that, with effort and resistance moving in *opposite directions*. That's great, because pushing down is easy. You have the weight of your body and gravity to help you.

## How does a 1st-class lever help you?

Many 1st-class levers make work easier, but not all do. It depends on which is closer to the fulcrum, the resistance or the effort. When the resistance is closer to the fulcrum, work is easier. When the effort is closer to the fulcrum, work is harder. Just picture yourself on a see-saw. It's not so easy to lift an adult if you're sitting too close to the fulcrum. But if you're sitting all the way at the end, the lever is helping you lift that weight.

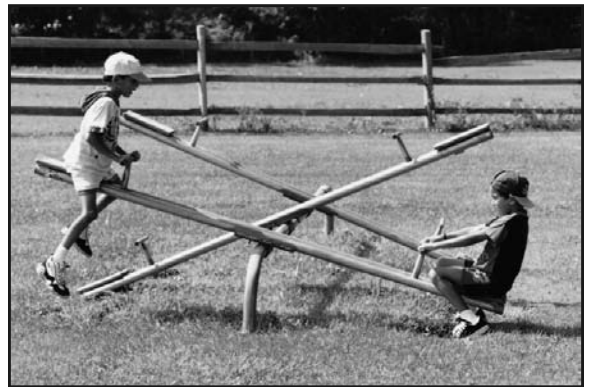
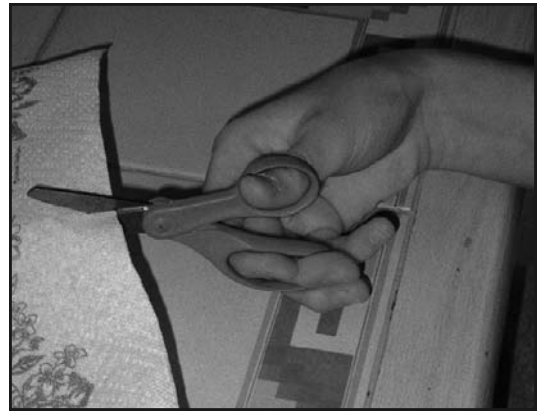

# What is a 2nd-class lever



**A 2nd-class lever has the RESISTANCE in the middle.** The **Fulcrum** and **Effort** are at opposite ends.



## Here's an example.

Picture a wheelbarrow full of sand. Your hands on the handles provide the effort, the sand is the resistance (what you are trying to lift) and the wheel is the fulcrum.



## Which way does a 2nd-class lever move?

When you **lift up** on the handles, your load of sand **goes up** too. A 2nd-class lever has its effort and resistance moving in the *same direction*.

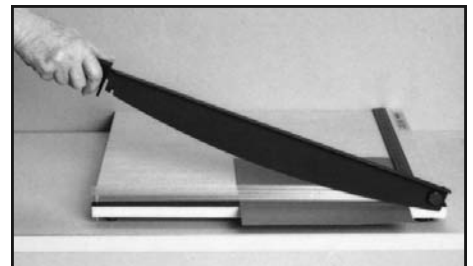

## How does a 2nd-class lever help you?

Like all 2nd-class levers, the wheelbarrow always makes work easier. Remember, increasing the distance reduces the effort needed. This lever reduces the force you need to do the job. That's because the effort is always farther from the fulcrum than the resistance. With a 2nd-class lever, you can move a large load with a small effort.



# What is a 3rd-class lever

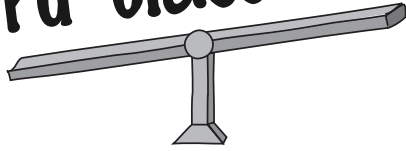

A **3rd-class lever** has the **EFFORT** in the middle. The **Fulcrum** and **Resistance** are at opposite ends.



## Here's an example.

You're holding a baseball bat, ready to swing. Your hands provide the effort, the ball is the resistance (the thing you are trying to move) and the fulcrum is at the bat's knob, below your hands.

## Which way does a 3rd-class lever move?

Swing the bat **forward** to hit the ball. Bam! The ball goes **forward** too. A 3rd class lever has its effort and resistance moving in the *same direction*.

## How does a 3rd-class lever help you?

In a 3rd-class lever, the effort arm is always shorter than the resistance arm. That means that the lever actually makes work harder. You have to apply more effort to move less resistance.

But 3rd class levers can still be helpful. When you swing the bat, you only have to move your hands a short distance. In the same amount of time, the end of the bat moves a much farther distance. It also moves faster than your hands. The fast-moving bat hits the ball and makes it go fast too.

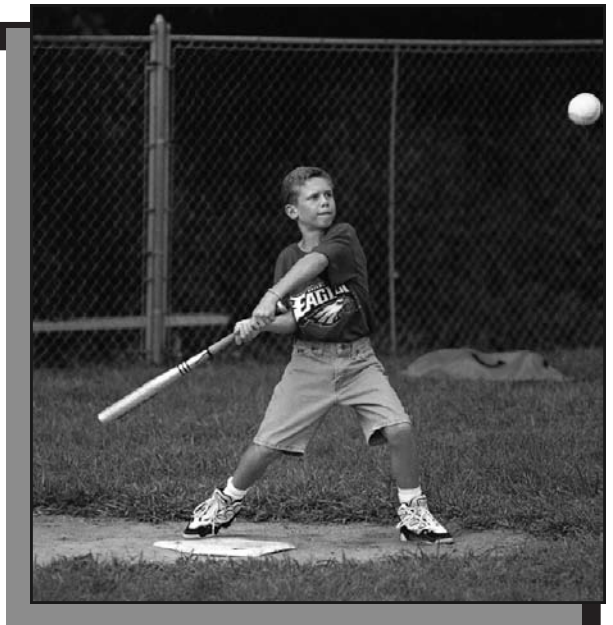

# Which class is your lever?

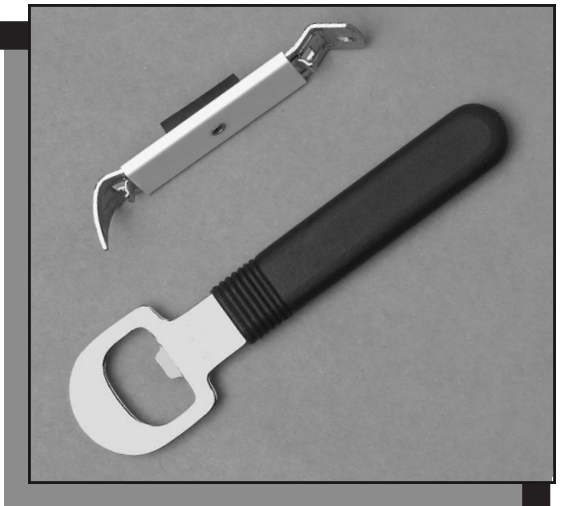
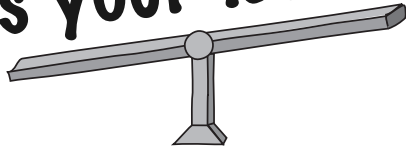

## To find out about your lever:

- Find the fulcrum, resistance and effort.
- Look for which one is in the middle.

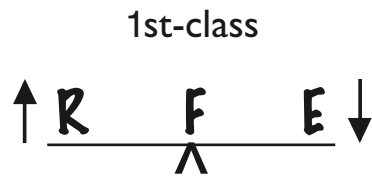

**Fulcrum**  
in the middle

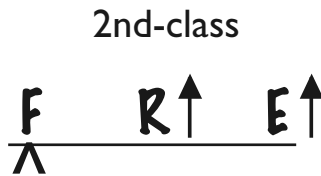

**Resistance**  
in the middle

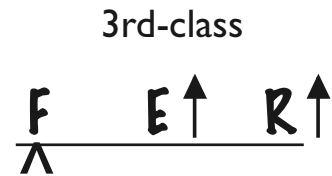

**Effort**  
in the middle

## What is a double lever?



A double lever is two levers attached to each other at the fulcrum. They might be a pair of 1st-class, 2nd-class or 3rd-class levers. The two levers work together to do one job.



### 1st-class: Pruning Shears

This double lever helps you trim your hedges.



### 2nd-class: Nutcracker

Put a walnut between these two levers and CRUNCH!

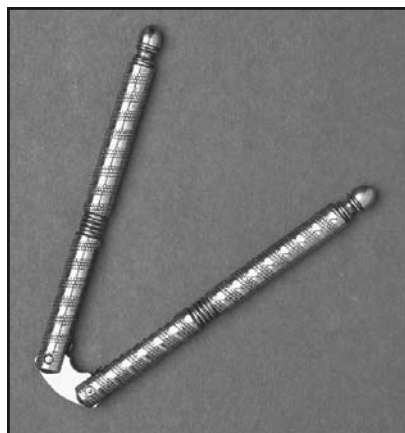

### 3rd-class: Ice tongs

Pinch the tongs and you can pick up a slippery ice cube.



# Balance Lesson Plan

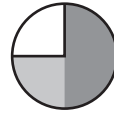
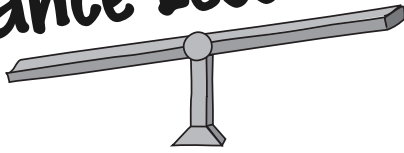

**Lesson Length:** 30-45 minutes

## Objectives

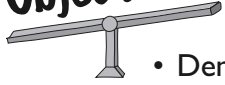

- Identify the fulcrum, resistance and effort on a balance
- Determine the lever class of a balance
- Demonstrate how the Balance functions as a 1st-class lever
- Measure forces applied to the Balance using weights
- Manipulate the Balance to determine the effects on required force
- Graph results of experiments
- Infer how the Balance does work based on measurements
- Experiment with the Balance to distinguish between classes of levers
- Manipulate the Balance to compare and contrast lever classes
- Measure forces with a Rubber Band Scale

## Materials

- 3 blank dot stickers or pieces of masking tape
- marker
- small object, such as a pencil, chalk or eraser
- 5-10 pennies, green Rods or other small unit weights
- 2 paper clips
- K'NEX Rubber Band Scale

## Every lever has a job to do

Balances, similar to the K'NEX Balance, are very helpful in situations where you need to compare the weights of different objects. The balance is a pair of scales. Comparable loads will put the balance in equilibrium and the arm will be perfectly horizontal. This type of machine is often found in a science lab or grocery store.

### What class of lever is it?

The Balance can be used as a 1st, 2nd or 3rd-class lever, depending on the placement of the Balance arm and the weights. As built according to the instructions, it is a 1st-class lever. Direct students to the “Student Reference Sheets”.

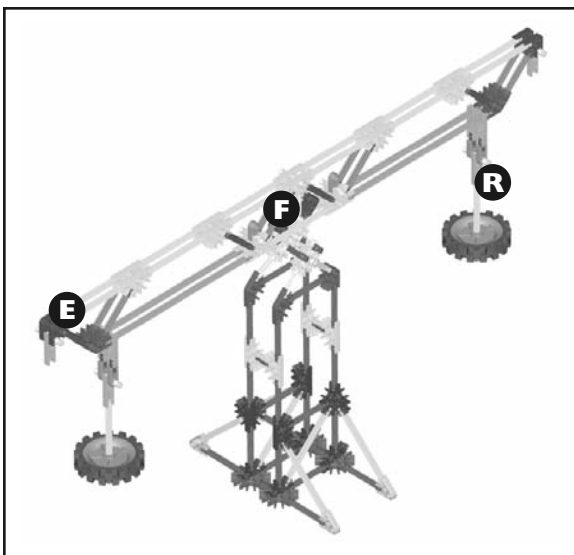

## Journal Check

- ✓ Force and distance measurements
- ✓ Graph of measurement results
- ✓ Interpretation of experiment results
- ✓ Explanatory paragraph for how Balance was altered to serve as other classes of levers

## QUESTIONS

- 1 Weigh a small object, such as a pencil, by placing it on one of the Balance trays (gray Hub). Use pennies or K'NEX pieces as weights on the other tray. Make sure each tray is set at the same distance from the middle of the Balance arm. Weigh and compare other objects. Design a graph to record and compare your results.
- 2
  - a. Measure the distance from the center of the Balance to the end of the arm where the object is weighed. Record this length. This is the resistance arm because the object being weighed resists or works against the lever.
  - b. Then, measure from the center to the end of the other arm, where the weights are. This is the effort arm because the weights supply the effort or work to make both sides equal and balanced. Record this length. Are the two distances the same? What does this show?
  - c. Shorten the effort arm by sliding the tray with the weights closer to the middle. Balance the arms again. Do you have to add or remove weights? What does this tell you? Choose the right word in this sentence to explain your findings:  
When the effort arm is shorter than the resistance arm, (more/less) effort is needed to do the work.
- 3 When built according to the instructions, what class lever is your Balance? Alter your Balance so it functions as each of the other class levers. Explain.

## ANSWERS

- 1 To place objects and weights on the Balance, students might use the hanging gray Hubs as trays, connect weights to the upright Rod or hang weights below. A larger object might be suspended below the Hub by hooking the object on a paper clip that hangs from the gray Connector.  
The graph should compare the variables, how many of the small weights it takes to balance the weight of the object.
- 2
  - a. Review the terms **resistance arm** and **effort arm** to help students differentiate between the two sides of the lever.
  - b. Help students see that the arms will balance when both sides are equal, in weight and in distance from the center. If the distance on one side changes, its weight must also change to keep in balance. Have students experiment with placing small objects on both sides of the Balance and shifting the trays to different positions.
  - c. Students should complete the sentence: When the effort arm is shorter than the resistance arm, **more effort** is needed to do the work. If you decrease the length of the effort arm, you have to increase the effort.
- 3 As built according to the instructions, it is a 1st-class lever. Students' answers will vary but should include an explanation of the resistance being in the center for a 2nd-class lever and the effort being in the center for a 3rd class lever.

# Balance Extensions



## Objectives



- Conduct experiments with the Balance to differentiate class and function
- Identify fulcrum, effort and load (resistance) in different Balance configurations
- Identify, reinforce and solidify understanding of effort and resistance arms
- Compare and contrast performance and results for each lever class of the Balance
- Measure force and distance for each lever class of the Balance
- Calculate Mechanical Advantage and work efficiency for the lever classes

L2= Left 2 yellow Connector  
L1= Left 1  
C= Center yellow Connector  
R1= Right 1  
R2= Right 2

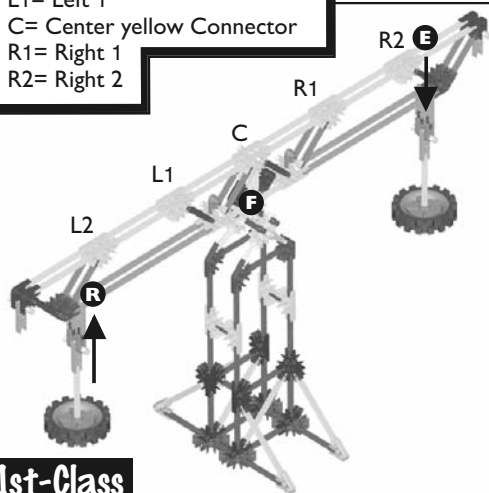

1st-Class



## Additional Activities using the K'NEX Balance

There are two different ways to change the lever class of the Balance: (1) slide the load on the gray Rods to change their position from the fulcrum; (2) disconnect the whole arm from the base of the Balance and snap it into one of the other sets of yellow Connectors on the top bar. This allows you to change the placement of the fulcrum.

## Feeling the Force: 1st, 2nd & 3rd-Class Balances

- 1 a. Set the fulcrum on the Balance in Position L2. Label the fulcrum and the resistance.
  - b. Remove the entire hanging arm and Tire load on the left side of the Balance, up to the orange Connector. Add the large Hub and Tire and four small Hubs and Tires as extra weights on the right hanging arm. Snap the right hanging arm onto the yellow Rods of the under arm of the Balance. (see 2nd-class photo)
  - c. Lift the load by applying effort to the opposite end of the arm. In what direction do you apply the effort? Record and explain your observations. Which class of lever is the Balance now? Why?
  - d. Lift the load by applying the effort at the end of the long arm. In what direction was the effort applied? Record and explain your observations. Compare these results to the previous test and explain what you find.
  - e. Which class of lever is the Balance now? Why?
  - f. For both tests, in which direction does the resistance move?
  - g. Use the K'NEX Rubber Band Scale to measure the forces and verify your results. Explain your findings.

[Push down on the opposite end of the arm and the resistance goes up. The Balance is a 1st-class lever which changes the direction of the force.

The Balance becomes a 2nd-class lever when applying the effort by pulling or pushing up the end of the long arm. The resistance also goes up. This takes less force because the effort arm is longer than the resistance arm.]

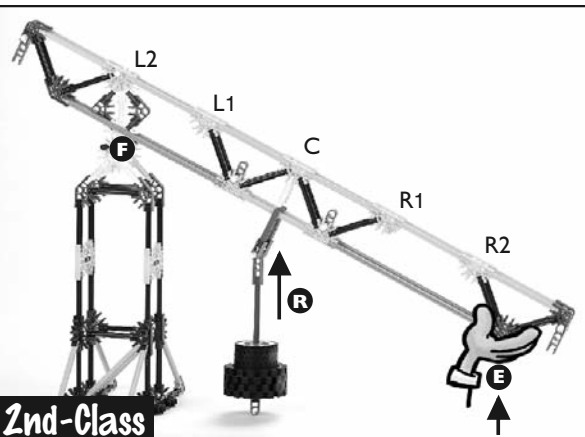

2nd-Class

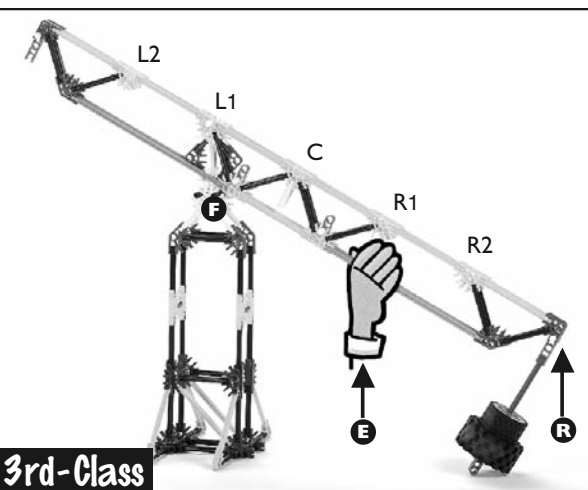

3rd-Class

## Materials

- K'NEX Balance
- weights (small & large Hubs and Tires)
- K'NEX Rubber Band Scale
- two metric rulers
- calculator (optional)
- masking tape
- markers

## Journal Check

- ✓ F, E and R labels for each lever class of the Balance
- ✓ Chart of distance measurements for 1st, 2nd and 3rd-class effort and resistance and corresponding distances the resistance rises
- ✓ Observations and explanations of test results for comparing all three classes of levers
- ✓ Force measurements for the Balance as all three classes of levers
- ✓ Calculations for Mechanical Advantage and work efficiency for different classes and lengths of EA and RA

- 2**
- Set the fulcrum on the Balance in Position L1. Label the fulcrum and resistance.
  - Repeat step 1b. Let the weights hang from the end of the right arm. (see 3rd-class photo)
  - Lift the load by using the Balance as a 1st-class lever. Where and in what direction do you apply the effort? What happens? Record and explain your observations.
  - Repeat step 2c for a 3rd-class lever.
  - For both tests, in which direction does the resistance move?
  - Repeat step 1g. Compare these results to the previous test and the tests in Activity 1. Draw a conclusion about levers based on these comparisons.

[Push down on the short end of the arm and the load goes up so the Balance is a 1st-class lever.

The Balance is a 3rd-class lever when pushing or pulling up on the arm between the fulcrum and the resistance. The resistance goes up also. Rubber Band Scale measurements will verify that the 3rd-class lever requires more force to lift the load than the 1st-class lever.]

## Exploring Distance for Each Lever Class

- Stand a ruler behind the resistance (load) and have a partner stand a second ruler behind the place where the effort is applied. Apply the effort and measure how the load and effort move. Compare the results. What do they show?
  - Describe, measure and record the length of the effort arm and resistance arm.

- Calculate the Mechanical Advantage for the Balance in this position. (Use the "What's the Mechanical Advantage" Reference Card for help.)

	Pull the EA Up:	The Load Rises:
Length of EA _____ cm	15cm	_____ cm
Length of RA _____ cm	10cm	_____ cm
	5cm	_____ cm
	Etc.	

- Which is greater, the distance the effort arm moved or the distance the load rises? Verify your results by testing at least three other points along the effort arm of your lever. Record these results and add them to the chart.

- Alter the Balance to function as a 2nd and 3rd-class lever. Repeat the test for each of these lever classes. Record and compare your results. What conclusions can you draw from these experiments? Describe how the EA moves for each class of lever.

- There is a direct relationship between work and distance. The formula for this relationship is very easy to use for levers. Use these formulas to calculate the efficiency of the Balance as each class of lever.

**Work output = Force (weight of load) x Distance (distance load rises)**

**Work input = Force (measurement) x Distance (EA moves)**

**Efficiency =  $\frac{\text{Work output}}{\text{Work input}} \times 100$**



# The Balance



## Every lever has a job to do

A balance helps you weigh things like letters or apples. It also helps you compare the weights of two different objects. To make a balance work, you put the object you want to weigh on one side of the balance. Then, on the other side of the balance, you place something else – usually gram weights. When the objects on each side weigh the same amount – the long arm of the balance is perfectly horizontal.

### Label your lever

Use stickers or tape to label the parts of the balance:

- F** Fulcrum
- R** Resistance
- E** Effort

\* See Building Instructions for help

### What class of lever is it?

Is your balance a 1st, 2nd, or 3rd class lever? Use these clues:

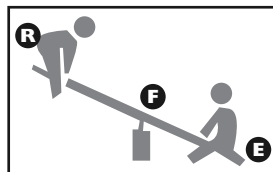

1st class

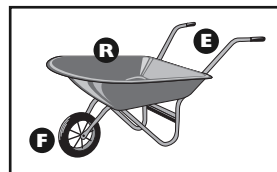

2nd class

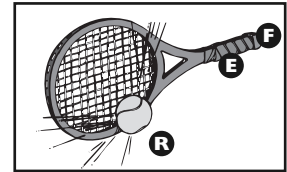

3rd class

## Student Challenge

- 1 Weigh a small object, such as a pencil, by placing it on one of the Balance trays (gray Hub). Use pennies or K'NEX pieces as weights on the other tray. Make sure each tray is set at the same distance from the middle of the Balance arm. Weigh and compare other objects. Design a graph to record and compare your results.
- 2
  - a. Measure the distance from the center of the Balance to the end of the arm where the object is weighed. Record this length. This is the resistance arm because the object being weighed resists or works against the lever.
  - b. Then, measure from the center to the end of the other arm, where the weights are. This is the effort arm because the

weights supply the effort or work to make both sides equal and balanced. Record this length. Are the two distances the same? What does this show?

c. Shorten the effort arm by sliding the tray with the weights closer to the middle. Balance the arms again. Do you have to add or remove weights? What does this tell you? Choose the right word in this sentence to explain your findings:  
When the effort arm is shorter than the resistance arm, (more/less) effort is needed to do the work.

- 3 When built according to the instructions, what class lever is your Balance? Alter your Balance so it functions as each of the other class levers. Explain.

# See-Saw Lesson Plan

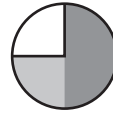
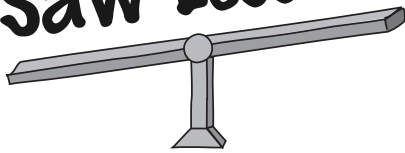

**Lesson Length:** 30-45 minutes

## Objectives

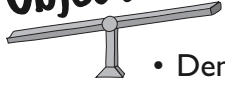

- Identify the fulcrum, resistance and effort on a see-saw
- Determine the lever class of a see-saw
- Demonstrate how the See-saw functions as a 1st-class lever
- Measure forces applied to levers using weights
- Experiment with the See-saw and Lifter models to distinguish between classes of levers
- Demonstrate how the Lifters function as a 2nd and 3rd-class levers
- Compare and contrast lever classes
- Infer purposes of different levers and classes of levers
- Measure forces with a Rubber Band Scale

## Materials

- 3 blank dot stickers or pieces of masking tape
- marker
- 2 paper clips
- paper cup
- 15-20 green Rods or pennies
- K'NEX Rubber Band Scale

## Every lever has a job to do

The see-saw is a simple piece of equipment that can provide a lot of amusement. If the two people on the see-saw are different sizes, the heavier person has to move closer to the middle in order to be lifted by the smaller person. Less effort is needed since the resistance is closer to the fulcrum.

### What class of lever is it?

The See-saw is a 1st-class lever.

The 2nd-class lifter is a 2nd-class lever.

The 3rd-class lifter is a 3rd-class lever.

Direct students to the “Student Reference Sheets”.

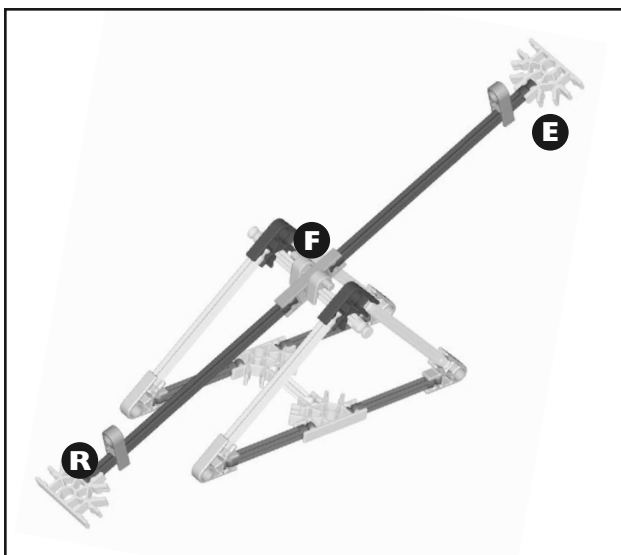

## Journal Check

- ✓ Force measurements
- ✓ Comparison of lever classes
- ✓ Explanatory paragraph for how different classes of levers help do work

## QUESTIONS

- 1
  - a. Attach the K'NEX Rubber Band Scale to a cup of pennies or other small items. Measure the force used to lift the cup. Record your result.
  - b. Slide the gray Connector on each arm of the See-saw to the end of its arm. Hang the cup on a paperclip from one gray Connector and attach the Scale to the other gray Connector with a paperclip.
  - c. Set the See-Saw on the corner of a desk so the cup hangs down freely. Measure the force needed to lift the cup. Record the measurement and compare it to the reading you got lifting the cup with the Scale alone? In what direction do you pull on the Scale? How does this prove that a see-saw is a 1st-class lever? (Refer to the "What is a 1st-class Lever" Reference Sheet.)
  - d. Slide the Connector that holds the weight to the center of the arm. Take another reading on the Scale and compare your results. How has the reading changed? What does this mean?
- 2
  - a. Build a 2nd-class Lifter and repeat steps 1b, 1c, 1d. Describe how it compares to the See-saw.
  - b. Build the 3rd-class Lifter and repeat steps 1b, 1c, 1d. Compare results of all the lever classes.
- 3
  - Write a paragraph explaining how each class of levers helps you do work.

## ANSWERS

- 1
  - a. Students need to measure the force used to lift the cup by itself in order to have a baseline measurement from which to compare how much the machine helped do the work.
  - b. The gray Connectors must be an equal distance from the fulcrum.
  - c. Students should find the measurements to be the same because the effort and resistance arms are the same distance from the fulcrum. Direction of force is changed but not the amount of force applied. With the fulcrum in the middle, the See-saw functions as a 1st-class lever.
  - d. The closer the weight is moved to the middle of the See-saw, the easier it is to lift, and the lower the reading on the Scale. The resistance arm is shorter than the effort arm so less force is needed.
- 2
  - a. Students should find that the 2nd-class Lifter requires less force to lift the load since the effort arm is longer than the resistance arm.
  - b. The 3rd-class Lifter takes more effort than the others since the effort arm is shorter than the resistance arm. By comparing how easy it is to lift weights, students should see how the three classes of levers differ. Have them compare the lengths of the effort and resistance arms in each lever to understand why one lever might lift weight more easily than another.
- 3
  - Students' answers will vary. Paragraph should include: clear explanation as to the differences between the lever classes; reference to the amount of effort that was needed to lift each load; and how using less effort would make a job easier.

# The See-Saw

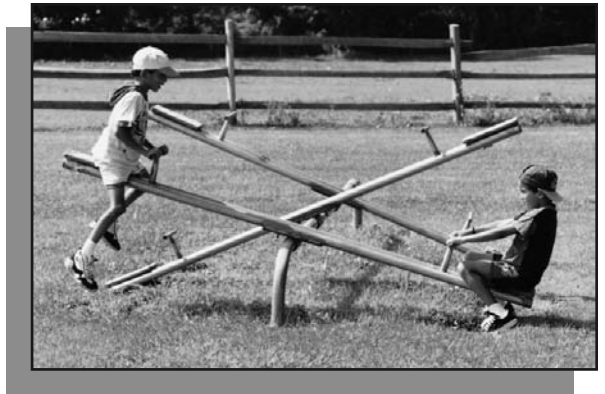
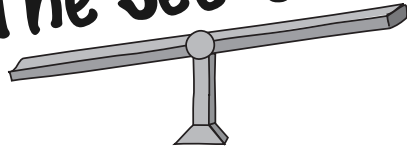

## Every lever has a job to do

This lever's job is to help kids have fun. It turns (pivots) at a center point, letting two people ride up and down. If both people are the same size and the same distance from the center point, the two sides of the see-saw balance. But how can it balance if one person is much bigger? Use your K'NEX model to find out.

### Label your lever

Use stickers or tape to label the parts of the see-saw:

- F** Fulcrum
- R** Resistance
- E** Effort

\* See Building Instructions for help

### What class of lever is it?

Is your see-saw a 1st, 2nd, or 3rd class lever? Use these clues:

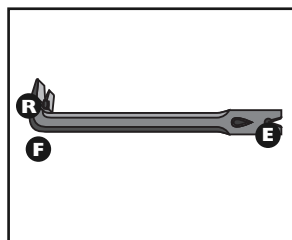

1st class

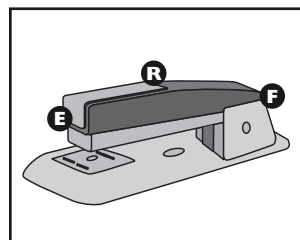

2nd class

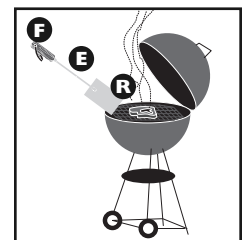

3rd class



- 1
  - a. Attach the K'NEX Rubber Band Scale to a cup of pennies or other small items. Measure the force used to lift the cup. Record your result.
  - b. Slide the gray Connector on each arm of the See-saw to the end of its arm. Hang the cup on a paperclip from one gray Connector and attach the Scale to the other gray Connector with a paperclip.
  - c. Set the See-Saw on the corner of a desk so the cup hangs down freely. Measure the force needed to lift the cup. Record the measurement and compare it to the reading you got lifting the cup with the Scale alone? In what direction do you pull on the Scale? How does this prove that a see-saw is a 1st-class lever? (Refer to the "What is a 1st-class Lever" Reference Sheet.)

d. Slide the Connector that holds the weight to the center of the arm. Take another reading on the Scale and compare your results. How has the reading changed? What does this mean?

- 2
  - a. Build a 2nd-class Lifter (following the instruction card) and repeat steps 1b, 1c, 1d. Describe how it compares to the See-saw.
  - b. Build the 3rd-class Lifter and repeat steps 1b, 1c, 1d. Compare results of all the lever classes.
- 3 Write a paragraph explaining how each class of levers helps you do work.

# Catapult Lesson Plan

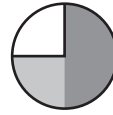
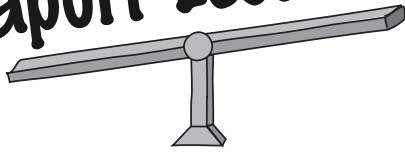

**Lesson Length:** 30-45 minutes

## Objectives

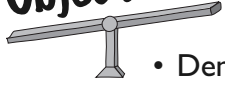

- Identify the fulcrum, resistance and effort on a catapult
- Determine the lever class of a catapult
- Demonstrate how the Catapult functions as a 1st-class lever
- Experiment with the Catapult and measure distances of various projectiles
- Modify and improve the Catapult based on an understanding of this lever class
- Evaluate test results to determine how the Catapult serves as a 1st-class lever
- Modify the Catapult to function as a 3rd-class lever
- Compare and contrast Catapult functioning as 1st and 3rd-class levers

## Materials

- 3 blank dot stickers or pieces of masking tape
- marker
- 1 to 2 marshmallows or wads of paper
- extra K'NEX pieces
- large rubber band

## Every lever has a job to do

Catapults may be used in modern times for fun, as clowns often do in the circus. In medieval times, however, catapults were used as weapons by launching heavy objects at the enemy. This is the reason for the long resistance arm on the catapult. The load usually needed to travel a long distance to reach into the enemy camp.

### What class of lever is it?

The Catapult is a 1st-class lever.  
Direct students to the “Student Reference Sheets”.

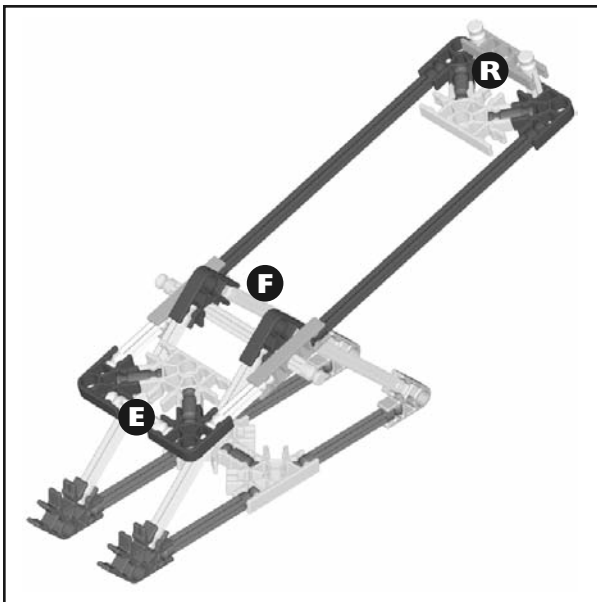

## Journal Check

- ✓ Distance measurements of launches
- ✓ Explanation of launch results
- ✓ Comparison of Catapult before and after modifications
- ✓ Explanation of method for changing Catapult from 1st to 3rd-class lever
- ✓ Description of how Catapult functions differently as a 1st and 3rd-class lever

## QUESTIONS

- 1 Find an open space and use your K'NEX Catapult to launch a marshmallow, cotton ball or wad of crumpled paper. Launch each object three times and measure the distance traveled for each launch. Find the average distance traveled by each object. Record your results.

What do you have to do to make the objects travel far? Compare the distances traveled by objects of different size and weight. Present your results in writing.

- 2 Identify the object that traveled the farthest. Now alter your K'NEX Catapult so this object will travel that distance using less force than with the original Catapult. Launch this item three more times and find the average distance traveled. Record your results and compare them to the results from the original version.

What did you do to successfully lengthen this distance? How do you know you used less force to launch the object? What does this prove about how this lever can help you?

- 3 Have a competition with your classmates. See who can shoot the object into a basket or hit a target the most times in a row.
- 4 Change your catapult into a 3rd-class lever. Attach rubber bands to the arm (between the fulcrum and the resistance) to provide the effort. How did you get it to work? What changes did you notice in how it worked or in the distance traveled by your object? How does this function differently as a 1st and 3rd class lever?

## ANSWERS

- 1 Have students work in an open space where they can easily and safely launch and retrieve their objects. They launch each object three times, record the results and find the average to ensure reliable results. To make the objects travel far, they must apply a lot of force to the effort arm of the Catapult.

- 2 They should have lengthened the effort arm. The Catapult is a 1st-class lever so the farther the effort is from the fulcrum, the easier it is to do work.

- 3 Set up mini-targets for students to aim at or allow them to shoot their objects into a bucket or wastebasket.

- 4 To change the Catapult from a 1st-class to a 3rd-class lever, students should remove the short arm and supply the effort in the middle of the long arm. This can be done by attaching a large rubber band to the middle of the long arm, stretching it around a fixed point in front of the Catapult and pulling the arm back for launching.

With the Catapult functioning as a 3rd-class lever, the students will have to apply more effort to have the loads travel their previous distances.

# The Catapult

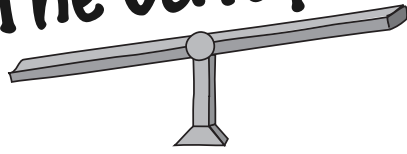

## Every lever has a job to do

A catapult is a lever that launches things into the air. Long ago, armies used catapults as weapons to throw large rocks or arrows. Circus performers also use catapults. An acrobat stands on one side of the catapult. When a clown jumps down on the other side, the acrobat goes flying into the air!

### Label your lever

Use stickers or tape to label the parts of the catapult:

- F** Fulcrum
- R** Resistance
- E** Effort

\* See Building Instructions for help

### What class of lever is it?

Is your catapult a 1st, 2nd, or 3rd class lever? Use these clues:

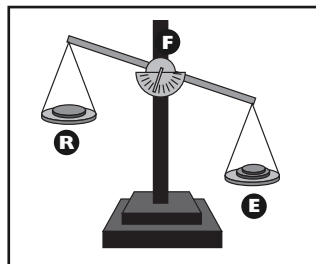

1st class

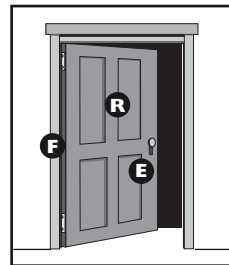

2nd class

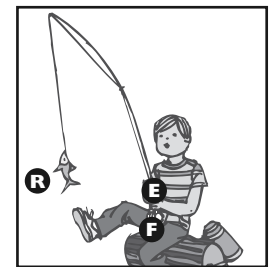

3rd class

Student Challenge

- 1** Find an open space and use your K'NEX Catapult to launch a marshmallow, cotton ball or wad of crumpled paper. Launch each object three times and measure the distance traveled for each launch. Find the average distance traveled by each object. Record your results.  
What do you have to do to make the objects travel far? Compare the distances traveled by objects of different size and weight. Present your results in writing.
- 2** Identify the object that traveled the farthest. Now alter your K'NEX Catapult so this object will travel that distance using less force than with the original Catapult. Launch this item three more times and find the average distance traveled. Record your results and compare them to the results from the original version.

What did you do to successfully lengthen this distance? How do you know you used less force to launch the object? What does this prove about how this lever can help you?

- 3** Have a competition with your classmates. See who can shoot the object into a basket or hit a target the most times in a row.
- 4** Change your catapult into a 3rd-class lever. Attach rubber bands to the arm (between the fulcrum and the resistance) to provide the effort. How did you get it to work? What changes did you notice in how it worked or in the distance traveled by your object? How does this function differently as a 1st and 3rd class lever?

**⚠ Safety Note: BE CAREFUL NOT TO OVERSTRETCH THE RUBBER BAND. Stretching can cause the Rubber Band to snap and cause injury. If you notice any deterioration of your Rubber Band, notify your teacher immediately.**

# Handcart Lesson Plan

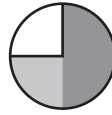
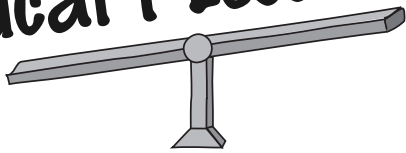

**Lesson Length:** 30-45 minutes

## Objectives

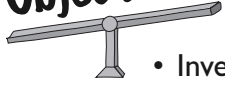

- Identify the fulcrum, resistance and effort on a handcart
- Determine the lever class of a handcart
- Investigate and demonstrate how the Handcart functions as a 1st-class lever
- Modify the Handcart to function more effectively
- Determine how the Handcart can be used as a 2nd-class lever

## Materials

- 3 blank dot stickers or pieces of masking tape
- marker
- small paperback book
- extra K'NEX pieces

## Every lever has a job to do

Handcarts are very popular machines and are often used by package delivery services, grocery stores and schools. (If the school has a handcart, let the class examine it and try using it.) To visualize the handcart as a lever, imagine it straightened out, with the upright Rods and lifting surface all in one plane. Then, the handcart looks more like a see-saw, with its fulcrum at the wheel axle. The handcart reinforces the idea that levers can have different shapes.

### What class of lever is it?

The Handcart is a 1st-class lever. [Note: A handcart can also function as a 2nd-class lever. If the object rests on the uprights and the handcart is moved horizontally, it serves as 2nd-class lever. The effort is still at the handles at the top and the fulcrum is still at the wheel, but the resistance is now on the uprights, which are in the middle.] Direct students to the “Student Reference Sheets”.

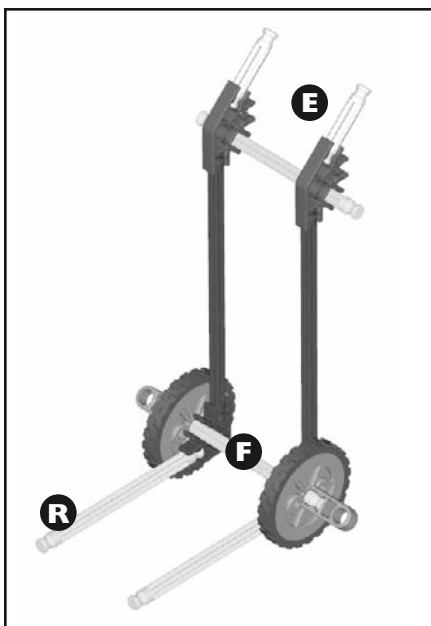

## Journal Check

- ✓ Explanation of why one way of lifting an object is easier than another
- ✓ Explanation of and reasoning for modifications to the Handcart

## Student Challenge

### QUESTIONS

- 1 Try moving books or other objects with your Handcart.
- 2 Now change the yellow Rods to red Rods. Lay a small book on the red Rods and try lifting it. Then, stand the book upright against the handles and lift. Which way is easier? Why?
- 3 Run a Handcart relay race! Build an object out of K'NEX and put weights in the bottom to make it heavy. Build short legs onto the object so you can slide the Handcart underneath to lift it. Have Handcart relay or obstacle course races. See how fast you can lift, move and transfer a load. The only rule: only the Handcart, not your hands, can touch the load.
- 4 Rebuild your Handcart so it can lift heavier loads. Does it help to make the Handcart taller? wider? sturdier? Write a few sentences explaining what you did and your reasons for this.

### ANSWERS

- 1 Testing a variety of loads will provide the students with a better understanding of how the Handcart serves as a 1st-class lever.
- 2 The closer the load is to the fulcrum (wheels), the easier it is for the Handcart to move. The students should grasp this concept as they try to lift the vertical book, which rests against the uprights, near the fulcrum as opposed to the flat book which has most of its weight away from the fulcrum.
- 3 Encourage students to be creative in planning a relay race. They can decide how many students should be on each team, how long the race course is and the design for the course.
- 4 The Handcart can be changed to lift heavier loads by making the uprights longer (lengthening the effort arm). However, the handles must still be easy to reach, so you don't want the uprights too long. Making the Handcart sturdier will not change the Mechanical Advantage, but it will keep the effort and resistance arms from bending.

# The Handcart

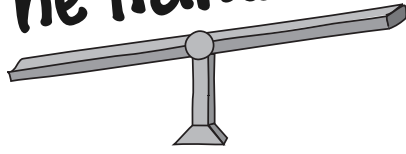

## Every lever has a job to do

How would you move a refrigerator? It's too heavy to pick up, even if you could get your arms around it. A handcart is a lever that can do the job. You can use a handcart to lift a heavy load and then roll it away.

### Label your lever

Use stickers or tape to label the parts of the handcart:

- F** Fulcrum
- R** Resistance
- E** Effort

\* See Building Instructions for help

### What class of lever is it?

Is your handcart a 1st, 2nd, or 3rd class lever? Use these clues:

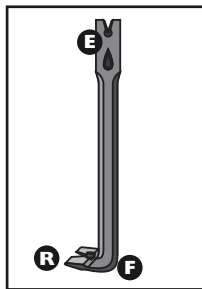

1st class

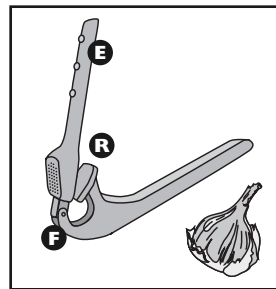

2nd class

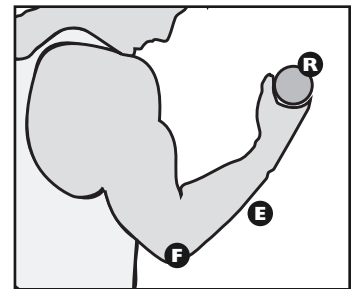

3rd class

## Student Challenge

- 1 Try moving books or other objects with your Handcart.
- 2 Now change the yellow Rods to red Rods. Lay a small book on the red Rods and try lifting it. Then, stand the book upright against the handles and lift. Which way is easier? Why?
- 3 Run a Handcart relay race! Build an object out of K'NEX and put weights in the bottom to make it heavy. Build short legs onto the object so you can slide the Handcart underneath to lift it. Have Handcart relay or obstacle course races. See how fast you can lift, move and transfer a load. The only rule: only the Handcart, not your hands, can touch the load.
- 4 Rebuild your Handcart so it can lift heavier loads. Does it help to make the Handcart taller? wider? sturdier? Write a few sentences explaining what you did and your reasons for this.

# Rowboat Lesson Plan

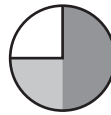

**Lesson Length:** 30-45 minutes

## Objectives

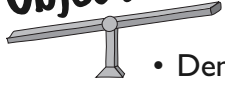

- Identify the fulcrum, resistance and effort on a rowboat oar
- Determine the lever class of a rowboat oar
- Demonstrate how the Rowboat's oars function as a 1st-class lever
- Understand how oar length affects Mechanical Advantage
- Build boat models based on research
- Compare and contrast oar designs for different boats
- Infer purpose of various oar designs and function based on research

## Materials

- 3 blank dot stickers or pieces of masking tape
- marker
- extra K'NEX pieces

## Every lever has a job to do

It is easy to see that a rowboat oar is a lever by turning the rowboat on its end and pulling down on the handle. In this position, the oar looks like a see-saw. The water is the weight that pushes against the other end of the lever as the rower supplies the effort.

### What class of lever is it?

Each Rowboat oar is a 1st-class lever. Direct students to the "Student Reference Sheets".

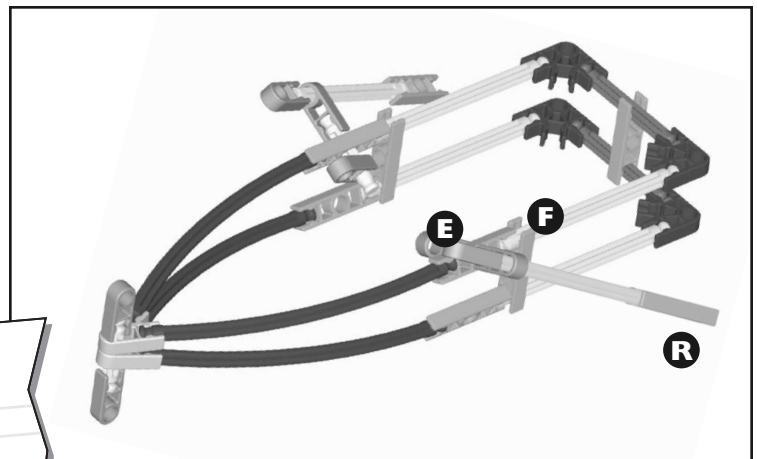

## Journal Check

- ✓ Explanation of how the Rowboat's travel direction demonstrates the lever class of the oars
- ✓ Explanation of which oar design provides more Mechanical Advantage
- ✓ Comparison of design and function of a rowboat's oars to those of the researched boat

## Student Challenge

### QUESTIONS

- 1 Try rowing the oars of your K'NEX Rowboat. As you pull the oars toward you, which way do they push against the water? Which way do the oars make the Rowboat move? (Make sure you're facing the correct way to move the Rowboat forward, point first.) Does the Rowboat move in the same direction as the oars when they are pushing against the water? What does this tell you about the effort and resistance applied to this lever?
- 2 Imagine your chair is the seat of a rowboat. Make big K'NEX oars for rowing. Which do you think would work better, longer handles or longer blades (the part that strokes the water)? Why? Which do you think provides more Mechanical Advantage (makes the rowing easier)? (Use the "What's the Mechanical Advantage" Reference Sheet for help.)
- 3 Find out about other kinds of boats, such as canoes, kayaks, racing sculls and galleys. How do the oars on these boats differ from each other? Build a K'NEX model of one of these boats and oars/paddles and compare it to the Rowboat oars. How are they the same? How are they different? Do they do the same work? Why are the oars designed this way?

### ANSWERS

- 1 To make a rowboat move forward (pointed end first), you should sit facing the back of the boat. By pulling the oars toward you, you push back against the water and move the boat forward. The resistance and the effort move in opposite directions.
- 2 Students should establish that the effort arm is the distance from the handle to the oarlock and the resistance arm is the distance from the oarlock to the point where the blade meets the water. If the effort arm is longer than the resistance arm, rowing will be easier, because there is a higher Mechanical Advantage. However, a short resistance arm will only move the boat a short way for every long stroke of the oar. Also, the effort arm can't be longer than the rower's arms will reach. The right length for an oar varies with the size of the person and the boat.
- 3 Oars can vary in length and in blade width. They can also have a single blade or a blade at each end. Encourage students to think about how these differences make the oars useful in different ways. For example, a double-blade oar can be used by one person to alternate strokes on either side of a narrow boat. Students should use a variety of references to compare different boats when designing their new models.

# The Rowboat

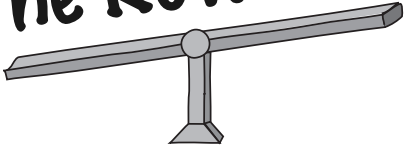

## Every lever has a job to do

Rowboats come in all shapes and sizes, for riding the rapids or canoeing down a quiet stream. But each kind of rowboat requires one or more oars to make it go. With its oars pushing back against the water, the boat slides forward. Oars are levers that help move the boat along.



### Label your lever

Use stickers or tape to label the parts of the rowboat:

- F** Fulcrum
- R** Resistance
- E** Effort

\* See Building Instructions for help

### What class of lever is it?

Is your rowboat a 1st, 2nd, or 3rd class lever? Use these clues:

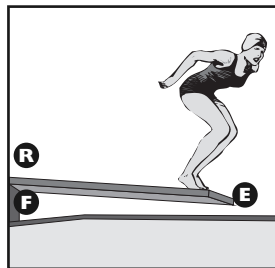

1st class

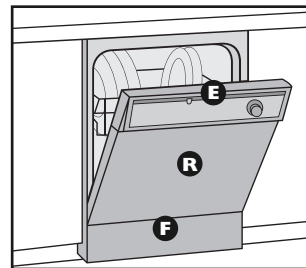

2nd class

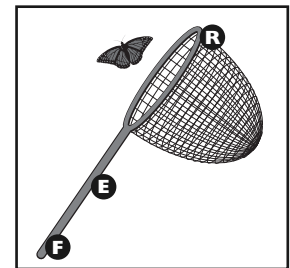

3rd class

## Student Challenge

- 1** Try rowing the oars of your K'NEX Rowboat. As you pull the oars toward you, which way do they push against the water? Which way do the oars make the Rowboat move? (Make sure you're facing the correct way to move the Rowboat forward, point first.) Does the Rowboat move in the same direction as the oars when they are pushing against the water? What does this tell you about the effort and resistance applied to this lever?
- 2** Imagine your chair is the seat of a rowboat. Make big K'NEX oars for rowing. Which do you think would work better, longer handles or longer blades (the part

that strokes the water)? Why? Which do you think provides more Mechanical Advantage (makes the rowing easier)? (Use the "What's the Mechanical Advantage" Reference Sheet for help.)

- 3** Find out about other kinds of boats, such as canoes, kayaks, racing sculls and galleys. How do the oars on these boats differ from each other? Build a K'NEX model of one of these boats and oars/paddles and compare it to the Rowboat oars. How are they the same? How are they different? Do they do the same work? Why are the oars designed this way?

# Scissors Lesson Plan

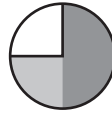
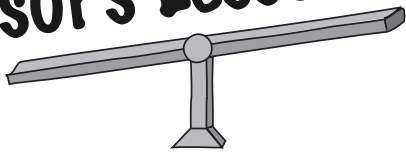

**Lesson Length:** 30-45 minutes

## Objectives

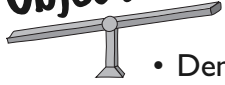

- Identify the fulcrum, resistance and effort on a scissors
- Determine the lever class of a scissors
- Demonstrate how the Scissors function as a 1st-class lever
- Understand why scissors are a double lever
- Infer the use of particular scissors based on their shapes and the characteristics of 1st-class levers
- Design and test an assortment of scissor-like tools

## Materials

- 3 blank dot stickers or pieces of masking tape
- marker
- extra K'NEX pieces

## Every lever has a job to do

For many levers, such as a balance, the resistance is a weight that the lever has to lift. In a pair of scissors, the resistance is the material it cuts. The material pushes back against the blades, just as a weight pushes down on the balance arm.

### What class of lever is it?

The Scissors is a double 1st-class lever. Direct students to the “Student Reference Sheets”.

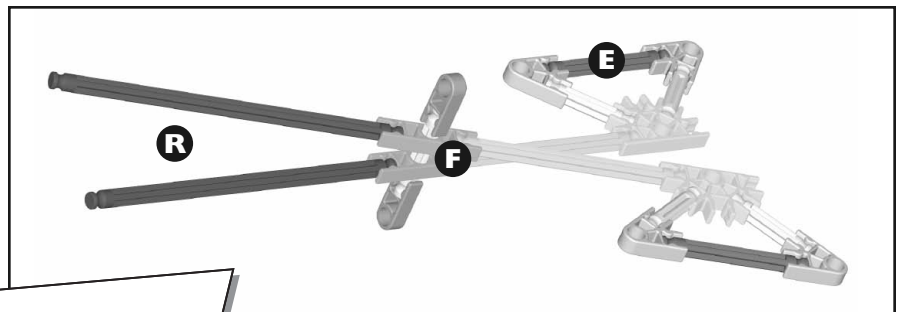

### Journal Check

- ✓ Explanation of where scissors have the most cutting power
- ✓ Explanation of how a scissors' shape affects the job it can perform

## Student Challenge

### QUESTIONS

- 1 Put your finger between the red Rods of your K'NEX Scissors, near the fulcrum. Then, squeeze the Scissors handles together. (Don't try this with real scissors!) Now move your finger out to the tips of the red Rods and squeeze again. Explain the difference you feel. Where do these levers have the most cutting power? What does this tell you?
- 2 a. The tools pictured here are different types of scissors. Locate the fulcrum, effort, and resistance on each of these scissors. How do the different locations of **F**, **E**, and **R** affect the jobs these scissors are designed to do?  
b. Make a K'NEX model of each of these different tools. Test them. Were your assumptions correct about their shape and purpose?



haircutting scissors



hedge trimmers

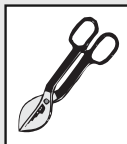

tin snips



lopping shears

### ANSWERS

- 1 To help students see that a scissors is a pair of levers, hold one part of the K'NEX Scissors upright while you let the other half swing freely like a see-saw. The scissors have the most cutting power near the fulcrum. If the resistance arm of a scissors is much shorter than its effort arm, cutting is easier. In a scissors, the length of the resistance arm changes as you cut through the material: the intersection of the blades shifts from near the fulcrum to the tips of the blades. Cutting near the fulcrum lets you apply more force, making cutting easier. Students should be able to feel this difference when they use the K'NEX Scissors to squeeze their fingers.
- 2 Different kinds of scissors are designed to cut different materials. A scissors with short blades and long handles has a large Mechanical Advantage. (The effort arm is much longer than the resistance arm.) Such scissors can cut heavy or thick materials. Tin snips or lopping shears are two examples of heavy-duty scissors. Other scissors don't need a large Mechanical Advantage. Haircutting scissors and hedge trimmers have long blades to help you make long, straight cuts.

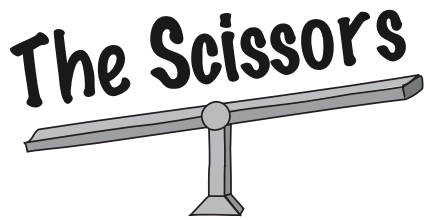

# The Scissors



## Every lever has a job to do

Most scissors cut through paper, hair and cloth, and there are special scissors that can cut through sheet metal or tree branches! Each scissors is actually a double lever, which is a pair of levers, held together by a pin in the middle. The size and shape of the scissors depends on what it has to cut.

### Label your lever

Use stickers or tape to label the parts of the scissors:

- F** Fulcrum
- R** Resistance
- E** Effort

\* See Building Instructions for help

### What class of lever is it?

Is your scissors a 1st, 2nd, or 3rd class lever? Use these clues:

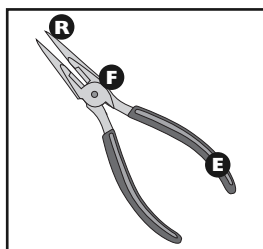

1st class

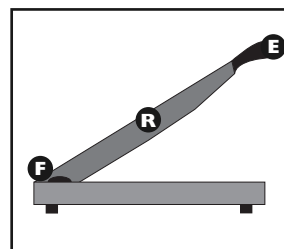

2nd class

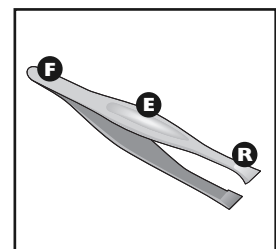

3rd class

## Student Challenge

- 1 Put your finger between the red Rods of your K'NEX Scissors, near the fulcrum. Then, squeeze the Scissors handles together. (Don't try this with real scissors!) Now move your finger out to the tips of the red Rods and squeeze again. Explain the difference you feel. Where do these levers have the most cutting power? What does this tell you?

- 2 a. The tools pictured here are different types of scissors. Locate the fulcrum, effort, and resistance on each of these

scissors. How do the different locations of **F**, **E** and **R** affect the jobs these scissors are designed to do?

- b. Make a K'NEX model of each of these different tools. Test them. Were your assumptions correct about their shape and purpose?

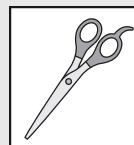

haircutting scissors

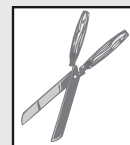

hedge trimmers



tin snips



lopping shears

# Door Lesson Plan

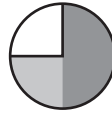
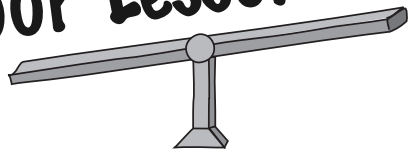

**Lesson Length:** 30-45 minutes

## Objectives



- Identify the fulcrum, resistance and effort on a door
- Determine the lever class of a door
- Demonstrate how the Door functions as a 2nd-class lever
- Measure forces applied to doors with a Rubber Band Scale
- Compare and contrast force measurements for different locations on a door
- Design and build a structure encompassing many 2nd-class levers

## Materials

- 3 blank dot stickers or pieces of masking tape
- marker
- masking tape
- K'NEX Rubber Band Scale
- extra K'NEX pieces

## Every lever has a job to do

Doors come in all shapes and sizes, like barn doors, bank vault doors or doors in fortresses and castles. Yet they all can be opened and closed with relative ease. That's because doors are 2nd-class levers with high Mechanical Advantage.

### What class of lever is it?

The Door is a 2nd-class lever.

Direct students to the "Student Reference Sheets".

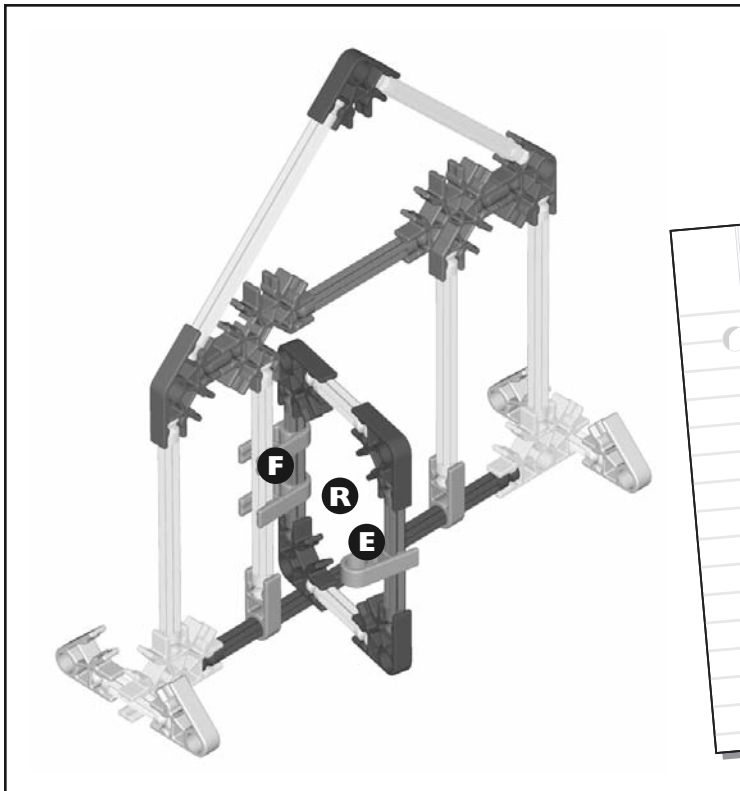

## Journal Check

- ✓ Force measurements
- ✓ Comparison and evaluation of force measurements
- ✓ Explanation of why its easiest to close a door at the doorknob

## Student Challenge

### QUESTIONS

- 1 Tie a long, heavy thread (or light cord) tightly around the reel of your K'NEX Fishing Rod. Then, run the thread through the gray Connector at the tip of the Rod. Make a hook by attaching an open paperclip to the end of the thread. Design and build some K'NEX "fish" by snapping together Connectors and Rods. Then, go fishing!
- 2 Once you've caught a K'NEX fish with your Fishing Rod, tilt the Rod up. You're using the Rod as a lever to lift the fish out of the water. Watch how far the fish moves, compared to how far your hands move in the same amount of time. Which moves faster the fish or your hands? How do you think this lever helps make catching a fish easier?
- 3 Build more fish of different sizes, weights and shapes and go fishing again. How is the Fishing Rod and your fishing experience affected by the weight of the fish? Write a paragraph to discuss this.

### ANSWERS

- 1 This lever's resistance is the weight of the Door itself, so the resistance arm is the distance from the hinges to the center of the Door's weight. The effort arm is the distance from the hinges to the doorknob. With this long effort arm, the whole door can be moved without using much force. Students should find that the Scale reading taken near the hinges is much higher than that taken near the doorknob. They might compare a tall, thin door with a short, wide door to see which is easier to open.
- 2 Encourage students to build houses with doors and shutters of different sizes and shapes.
- 3 It is easier to close the door at the doorknob because that is the place where the effort arm is the longest so the Mechanical Advantage is highest.



# The Door

## Every lever has a job to do

“Please close the door on your way out!”

What if that meant that you had to lift a big, wooden panel and fit it in the doorway? Swinging a hinged door closed is much easier. Closing a door is no problem, because a door is a lever. It’s designed to make work easier.



### Label your lever

Use stickers or tape to label the parts of the door:

- F** Fulcrum
- R** Resistance
- E** Effort

\* See Building Instructions for help

### What class of lever is it?

Is your door a 1st, 2nd, or 3rd class lever? Use these clues:

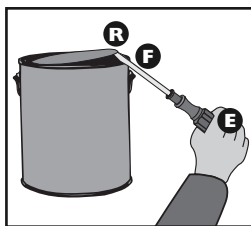

1st class

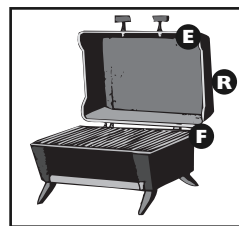

2nd class

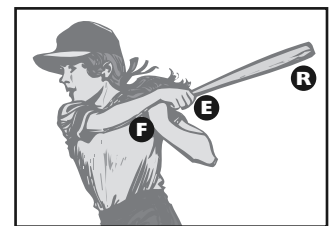

3rd class



- 1 a. Build and use a K’NEX Rubber Band Scale to measure how much force it takes to open the K’NEX Door. Attach the Scale to the Door by running the string from the Scale under the Door and taping it securely on the back side of the Door. Then, pull on the Scale to make the Door open. Check the reading on the Scale.  
b. Take readings with the Scale attached near the outside edge of the Door and near the hinges. Compare your readings. What do you find? Carefully, try measuring a variety of real doors and compare your results.
- 2 Build a K’NEX house with lots of doors and windows with shutters that open and close. See how many of these levers you can fit on one house.
- 3 Open a real door and then try closing it by pushing on the doorknob. Now close the door by pushing on the door at least a hands length away from the hinges. (Be careful not to pinch your fingers in the hinges.) Which way is easier? Why?

# Wheelbarrow Lesson Plan

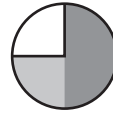
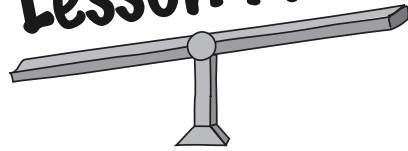

**Lesson Length:** 30-45 minutes

## Objectives



- Identify the fulcrum, resistance and effort on a wheelbarrow
- Determine the lever class of a wheelbarrow
- Demonstrate how the Wheelbarrow functions as a 2nd-class lever
- Manipulate the Wheelbarrow to determine how it can be utilized most effectively
- Modify the Wheelbarrow to make lifting a load easier
- Compare and contrast the lever classes and uses for wheelbarrows and handcarts
- Research and compare a travois to a wheelbarrow

## Materials

- 3 blank dot stickers or pieces of masking tape
- marker
- tape
- paper, plastic wrap or aluminum foil
- a pile of paperclips, chalk or pennies
- extra K'NEX pieces

## Every lever has a job to do

A wheelbarrow is a compound machine, combining a lever for lifting a load with a wheel for moving it. Wheelbarrows have been around for a long time and are used all over the world. They carry all kinds of loads and can roll easily across rough ground or up and down ramps.

### What class of lever is it?

The Wheelbarrow is a 2nd-class lever.

Direct students to the “Student Reference Sheets”.

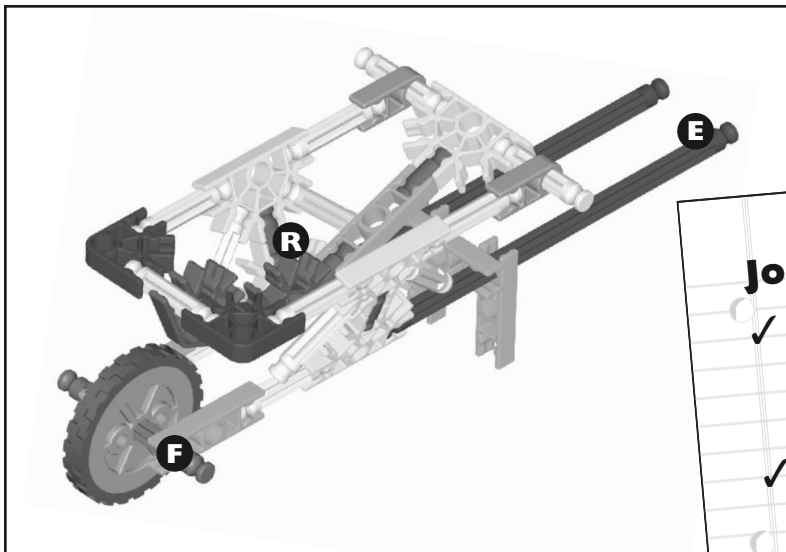

## Journal Check

- ✓ Explanation of what wheelbarrows can carry and why they may be easier to use than wagons
- ✓ Comparison between wheelbarrows and handcarts
- ✓ Summary of what a travois is, what it does and how it compares to a wheelbarrow

## Student Challenge

### QUESTIONS

- 1 Line the carrying space of your K'NEX Wheelbarrow with aluminum foil, paper or plastic wrap. Then, load up the Wheelbarrow with paperclips, chalk or K'NEX pieces. Use the Wheelbarrow to lift, move and then dump the load (by swinging it up and over the wheel). Which kinds of loads do you think are best for carrying in a real wheelbarrow? Why might a wheelbarrow be easier to use than a wagon?
- 2 Change your Wheelbarrow to make lifting even easier. *[Hint: Measure the distance from the wheel to the load (the resistance arm), and from the wheel to the handles (the effort arm.)]* When the effort arm is longer than the resistance arm, lifting is easier.
- 3 Wheelbarrows and handcarts do similar jobs. Why are they in different classes of levers? How does this affect how and when they are used?
- 4 Find out what a travois is and how Native Americans on the Plains used this device to move heavy loads. How is a travois like a wheelbarrow?

### ANSWERS

- 1 Students should see that wheelbarrows are great for moving materials like sand or bricks that can be heaped up and dumped out. The lever action of the wheelbarrow makes it easier to dump than a wagon. The whole wagon would have to be turned over to dump something out which would be especially difficult if the load was very heavy.
- 2 To make lifting a load with the Wheelbarrow even easier, students could move the load closer to the fulcrum or make the handles longer. Either way, the ratio of the effort arm to the resistance arm increases, so the force needed for lifting decreases.
- 3 The handcart has its fulcrum in the middle. It can be used to lift heavy, solid loads. The wheelbarrow has its resistance in the middle. It's basket is great for loose loads.
- 4 A travois is a device used for carrying a load. It consists of a pair of long poles, hitched to a horse or dog, with the load strapped across the poles. The other ends of the poles drag on the ground behind the animal. A travois is like a wheelbarrow without the wheel, and it is pulled instead of pushed.

# The Wheelbarrow



## Every lever has a job to do

Hauling sand, bricks or raked leaves is much easier if you have a wheelbarrow. The wheelbarrow works as a lever to help you lift a heavy load off the ground. Putting the load's weight near the wheel lets the wheel do most of the work to move the load along.



### Label your lever

Use stickers or tape to label the parts of the wheelbarrow:

- F** Fulcrum
- R** Resistance
- E** Effort

\* See Building Instructions for help

### What class of lever is it?

Is your wheelbarrow a 1st, 2nd, or 3rd class lever? Use these clues:

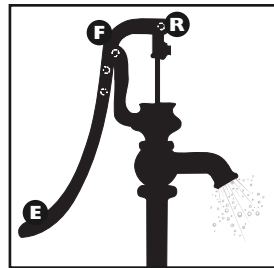

1st class

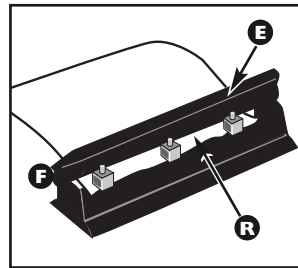

2nd class



3rd class

## Student Challenge

- 1** Line the carrying space of your K'NEX Wheelbarrow with aluminum foil, paper or plastic wrap. Then, load up the Wheelbarrow with paperclips, chalk or K'NEX pieces. Use the Wheelbarrow to lift, move and then dump the load (by swinging it up and over the wheel). Which kinds of loads do you think are best for carrying in a real wheelbarrow? Why might a wheelbarrow be easier to use than a wagon?
- 2** Change your Wheelbarrow to make lifting even easier. [Hint: Measure the distance from the wheel to the load (the resistance

arm), and from the wheel to the handles (the effort arm.)] When the effort arm is longer than the resistance arm, lifting is easier.

- 3** Wheelbarrows and handcarts do similar jobs. Why are they in different classes of levers? How does this affect how and when they are used?
- 4** Find out what a travois is and how Native Americans on the Plains used this device to move heavy loads. How is a travois like a wheelbarrow?

# Fishing Rod Lesson Plan

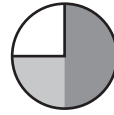
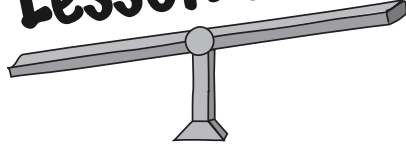

**Lesson Length:** 30-45 minutes

## Objectives

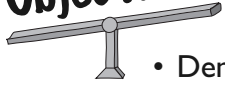

- Identify the fulcrum, resistance and effort on a fishing rod
- Determine the lever class of a fishing rod
- Demonstrate how the Fishing Rod functions as a 3rd-class lever
- Manipulate the Fishing Rod to determine how it can be utilized most effectively
- Understand how a fishing rod makes work easier
- Evaluate how the weight of the fish affects the Fishing Rod

## Materials

- 3 blank dot stickers or pieces of masking tape
- marker
- heavy thread
- paperclip
- extra K'NEX pieces

## Every lever has a job to do

As a 3rd-class lever, a fishing rod doesn't provide any Mechanical Advantage. In other words, the work of lifting the rod with its fish is more than the work of just lifting the fish. However, the rod helps by lifting the fish up quickly, before it can get away.

### What class of lever is it?

The Fishing Rod is a 3rd-class lever. Direct students to the "Student Reference Sheets".

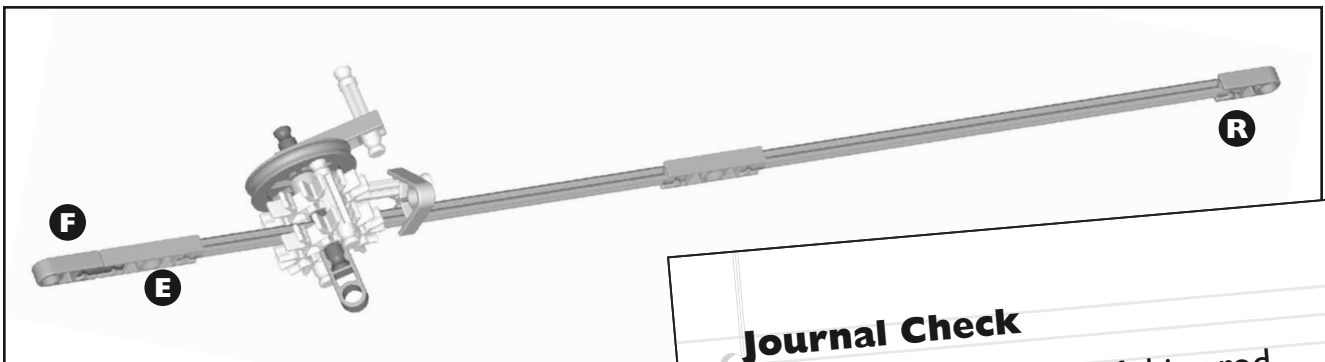

### Journal Check

- ✓ Explanation of how a fishing rod makes work easier
- ✓ Explanatory paragraph for how the size, weight and shape of the fish affect the work done by the Fishing Rod

## Student Challenge

### QUESTIONS

- 1 Tie a long, heavy thread (or light cord) tightly around the reel of your K'NEX Fishing Rod. Then, run the thread through the gray Connector at the tip of the Rod. Make a hook by attaching an open paperclip to the end of the thread. Design and build some K'NEX "fish" by snapping together Connectors and Rods. Then, go fishing!
- 2 Once you've caught a K'NEX fish with your Fishing Rod, tilt the Rod up. You're using the Rod as a lever to lift the fish out of the water. Watch how far the fish moves, compared to how far your hands move in the same amount of time. Which moves faster the fish or your hands? How do you think this lever helps make catching a fish easier?
- 3 Build more fish of different sizes, weights and shapes and go fishing again. How is the Fishing Rod and your fishing experience affected by the weight of the fish? Write a paragraph to discuss this.

### ANSWERS

- 1 To catch a K'NEX fish, students should hook the Rod's paperclip through any of the holes on the fish's Connector. You might stage a fishing derby to see who can catch the most fish in a given amount of time.
- 2 As the Fishing Rod is pulled up, the fish moves through a much longer distance than the student's hands, but both move in the same period of time. As a result, the tip of the Rod (and the fish attached to it) actually moves much more quickly than the hands. The quick action helps catch the fish before it wriggles away.  
Another benefit of a fishing rod is that it extends the reach out over the water. Without a rod, the fishing line would have to be dropped straight down, where there might not be any fish instead of further out in the water.
- 3 Students' answers will vary. Paragraphs should include a reference to the weight of the fish affecting the resistance on the Fishing Rod.

# The Fishing Rod

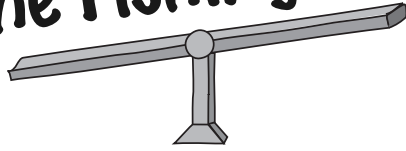

## Every lever has a job to do

A fishing rod can be as simple as a stick and a string, or it can be high-tech, complicated and expensive. Either way, it's a lever that helps you lift a fish out of the water.



### Label your lever

Use stickers or tape to label the parts of the fishing rod:

- F** Fulcrum
- R** Resistance
- E** Effort

\* See Building Instructions for help

### What class of lever is it?

Is your fishing rod a 1st, 2nd, or 3rd class lever? Use these clues:

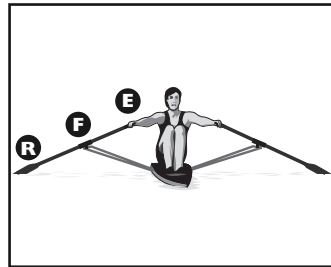

1st class

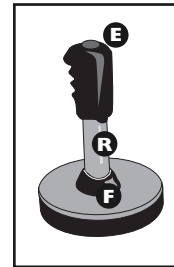

2nd class

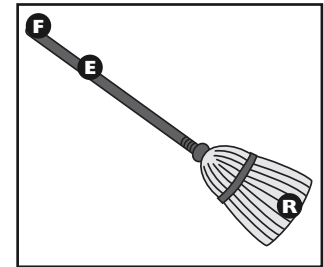

3rd class

## Student Challenge

- 1 Tie a long, heavy thread (or light cord) tightly around the reel of your K'NEX Fishing Rod. Then, run the thread through the gray Connector at the tip of the Rod. Make a hook by attaching an open paperclip to the end of the thread. Design and build some K'NEX "fish" by snapping together Connectors and Rods. Then, go fishing!
- 2 Once you've caught a K'NEX fish with your Fishing Rod, tilt the Rod up. You're using the Rod as a lever to lift the fish out

of the water. Watch how far the fish moves, compared to how far your hands move in the same amount of time. Which moves faster the fish or your hands? How do you think this lever helps make catching a fish easier?

- 3 Build more fish of different sizes, weights and shapes and go fishing again. How is the Fishing Rod and your fishing experience affected by the weight of the fish? Write a paragraph to discuss this.

# Hammer Lesson Plan

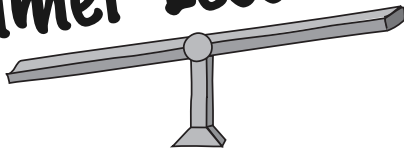

**Lesson Length:** 30-45 minutes

## Objectives

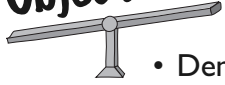

- Identify the fulcrum, resistance and effort on a hammer
- Determine the lever class of a hammer
- Demonstrate how the Hammer functions as both a 1st and a 3rd-class lever
- Identify purposes of a hammer
- Manipulate the Hammer to determine how to obtain the most Mechanical Advantage
- Compare and contrast the functioning of a hammer and a scissors
- Design a hammer for a specific purpose
- Differentiate between the uses of a claw hammer and how it serves as two separate levers

## Materials

- 6 blank dot stickers or pieces of masking tape
- marker
- small piece of modeling clay
- extra K'NEX pieces

## Every lever has a job to do

A claw hammer is not a “double lever,” such as scissors or pliers, in which two identical levers work together to do one job. The hammer head and the claw are two different kinds of levers, and they never can be used at the same time.

### What class of lever is it?

The Hammer’s head is a 3rd-class lever, while the claw is a 1st-class lever. Direct students to the “Student Reference Sheets”.

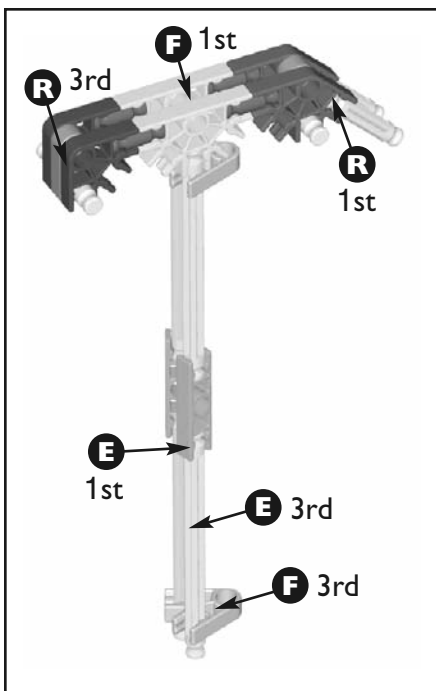

## Journal Check

- ✓ List of ways to use a hammer
- ✓ Explanation of the easier method for flattening the clay
- ✓ Comparison of hammers and scissors
- ✓ Explanatory paragraph for the purpose of the new hammer model and how the design allows it to do its job
- ✓ Description of the difference of how it feels to use a hammer as a 3rd and 1st-class lever

## Student Challenge

### QUESTIONS

- 1 Your K'NEX Hammer isn't built to drive in nails, but you could use it for other jobs. Brainstorm with friends to think of three ways to use your Hammer. (*Hint: Think of other kinds of hammers you've seen.*)
- 2 Hold the K'NEX Hammer near the end of the handle and try to flatten a ball of modeling clay. Count the number of blows it takes to flatten the clay. Now, grip the Hammer closer to the head and try to flatten the clay again. How many blows does it take this way? Which way works better? Why? How does this compare to the way scissors work? (*Refer to the "What's the Mechanical Advantage" Reference Sheet.*)
- 3 Modify your K'NEX Hammer or build another version that can be used to do a specific job. Describe, in writing, what your hammer is used for and how the design allows it to do this job.
- 4 Use a real claw hammer to drive in and remove nails from a piece of wood. How are the two jobs different? You can actually feel the difference in your arm and hand since you use distinct muscles to drive in and remove the nails. Describe this by identifying where you applied the effort, where you felt resistance and what class of lever the hammer was in each job.

### ANSWERS

- 1 Students answers will vary. The K'NEX Hammer might be used as a doctor's hammer for testing the knee reflex, the hammers inside a piano, a meat tenderizer or a percussion mallet.
- 2 Students should find that holding the Hammer near the end of the handle gives them more force, so they can hammer more easily, flattening the clay in fewer blows. A grip near the end provides a greater Mechanical Advantage than a grip near the head, because the effort arm is at its maximum. Ask them if they have ever noticed that carpenters hold their hammers near the end, so they only need a few strong blows to drive in a nail.
- 3 Students should clearly describe the benefits of their new hammer based on its design.
- 4 When the hammer is used as a 3rd-class lever to drive in the nail, the effort is applied where the hand is holding the handle and the fulcrum is at the end of the handle. You can feel the resistance in your hand as you are banging on the nail. When the hammer is used as a 1st-class lever, the fulcrum is found on the head of the hammer. As you apply the effort by pulling back on the handle, the nail moves forward. In this situation, the resistance is felt in the forearm.



# The Hammer

## Every lever has a job to do

You can use a hammer two ways, to drive nails into something, like a piece of wood or pull them out. A hammer is really two levers in one. The hammer head acts as one kind of lever, and the hammer claw as another.



### Label your lever

Use stickers or tape to label the parts of the hammer:

#### Hammer Head:

- F** Fulcrum
- R** Resistance
- E** Effort

#### Hammer Claw:

- F** Fulcrum
- R** Resistance
- E** Effort

\* See Building Instructions for help

### What class of lever is it?

Is your hammer a 1st, 2nd, or 3rd class lever? Use these clues:

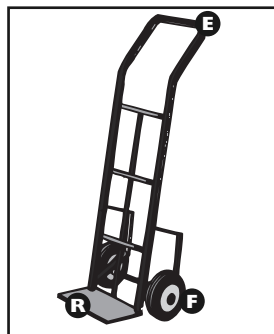

1st class

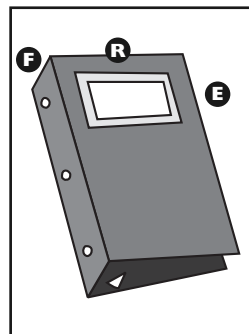

2nd class

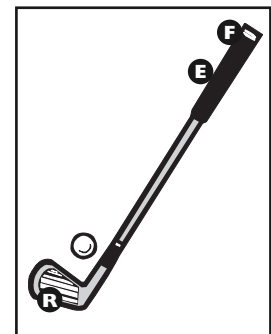

3rd class

## Student Challenge

- 1** Your K'NEX Hammer isn't built to drive in nails, but you could use it for other jobs. Brainstorm with friends to think of three ways to use your Hammer. (*Hint: Think of other kinds of hammers you've seen.*)
- 2** Hold the K'NEX Hammer near the end of the handle and try to flatten a ball of modeling clay. Count the number of blows it takes to flatten the clay. Now, grip the Hammer closer to the head and try to flatten the clay again. How many blows does it take this way? Which way works better? Why? How does this compare to the way scissors work? (*Refer to the "What's the Mechanical Advantage" Reference Sheet.*)
- 3** Modify your K'NEX Hammer or build another version that can be used to do a specific job. Describe, in writing, what your hammer is used for and how the design allows it to do this job.
- 4** Use a real claw hammer to drive in and remove nails from a piece of wood. How are the two jobs different? You can actually feel the difference in your arm and hand since you use distinct muscles to drive in and remove the nails. Describe this by identifying where you applied the effort, where you felt resistance and what class of lever the hammer was in each job.

# Tweezers Lesson Plan

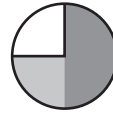
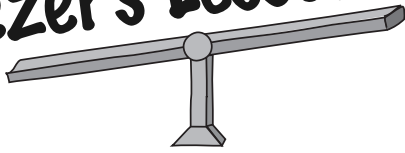

**Lesson Length:** 30-45 minutes

## Objectives

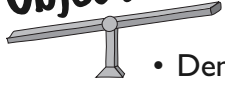

- Identify the fulcrum, resistance and effort on a tweezers
- Determine the lever class of a tweezers
- Demonstrate how the Tweezers functions as a 3rd-class lever
- Understand why tweezers are a double lever
- Manipulate the Tweezers to determine how to obtain the most Mechanical Advantage
- Build large tweezers to determine if size affects functioning and Mechanical Advantage

## Materials

- 3 blank dot stickers or pieces of masking tape
- marker
- 2 meter/yardsticks or rulers
- heavy tape
- balloons
- extra K'NEX pieces

## Every lever has a job to do

Tweezers are a double lever. It is a pair of 3rd-class levers that are joined by a flexible hinge. Squeezing the two levers together lets you pick up delicate objects like a stamp or small objects like a splinter, which need to be manipulated with a light touch.

### What class of lever is it?

The Tweezers is a double 3rd-class lever. Direct students to the “Student Reference Sheets”.

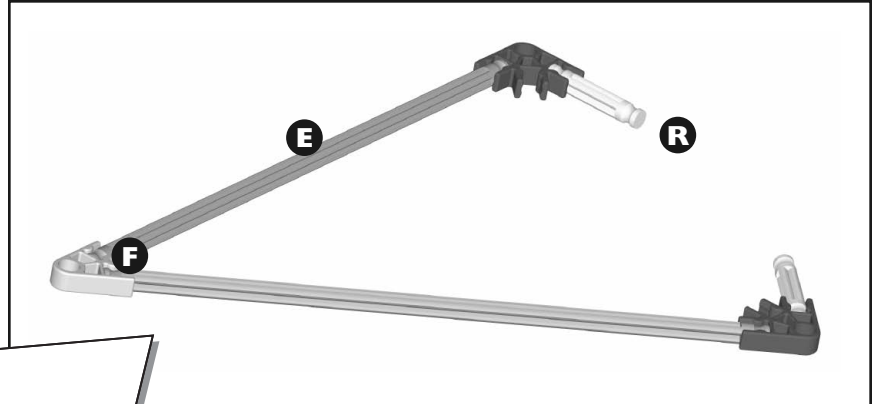

## Journal Check

- ✓ Description of the best way to manipulate the Tweezers
- ✓ Explanation of how to achieve the highest Mechanical Advantage
- ✓ Explanation of how size of tweezers may affect function and Mechanical Advantage

## QUESTIONS

- 1 Grip your K'NEX Tweezers near the hinge and squeeze. Can you make the tips touch? Now grip the Tweezers closer to the tips and squeeze again. Try to pick up something light, like a piece of paper. Which grip makes it easier to do this? Is this the same grip that lets you squeeze tighter?
- 2 When do you get the highest Mechanical Advantage, when you squeeze the Tweezers near the hinge or near the tips? (*Refer to the "What's the Mechanical Advantage" Reference Sheet.*)
- 3 Make a huge tweezers by taping together two rulers or meter/yardsticks with heavy tape. Use your new tool to gently pick up an inflated balloon. Try to make large K'NEX Tweezers that work the same way. How does the size of the tweezers affect the way they work and their Mechanical Advantage? (*Refer to the "What's the Mechanical Advantage" Reference Sheet.*)

## ANSWERS

- 1 When squeezing the Tweezers near the hinge, it is hard to bring the tips together. Squeeze near the tips and it's easy to make the Tweezers grip firmly. Have students imitate a tweezer grip by pinching together their thumbs and index fingers. Note that the fulcrum is at the base of the hand, the effort is provided by the muscles along the finger and thumb, and the resistance is the object being pinched.
- 2 A lever's Mechanical Advantage is the ratio of the length of its effort arm to the length of its resistance arm. The closer to the tips of the Tweezers you squeeze, the longer the effort arm, so the higher the Mechanical Advantage. For any 3rd-class lever, the Mechanical Advantage is always less than one. In the case of the Tweezers, this means that the Tweezers are not gripping with as much force as your fingers are squeezing. This works out well need since it's not necessary to use a lot of force in the jobs that tweezers do; in fact too much force would be counter-productive.
- 3 Students can make huge tweezers by laying the two meter/yardsticks flat against each other and making a tape hinge at one end. (You may also want to try this with rulers and compare.)  
  
Students might make large K'NEX Tweezers by using Rods and Connectors to lengthen the two arms of their Tweezers. Guide students to see how these large levers can have a light touch.

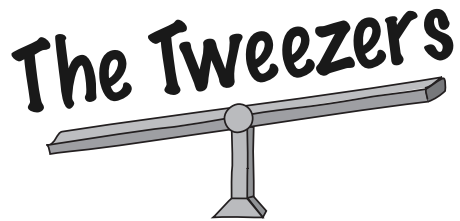

## Every lever has a job to do

When a splinter is stuck in your thumb, you need a tweezers to pull it out. Using a tweezers is like having tiny fingers to grip something very small. You can also use tweezers to gently pick up fragile objects, such as pressed flowers. Some robots have a tweezers-type tool. It's programmed to grip an object securely without crushing it.

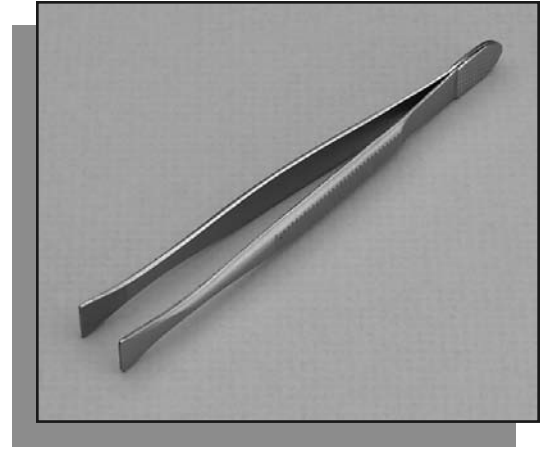

### Label your lever

Use stickers or tape to label the parts of the tweezers:

- F** Fulcrum
- R** Resistance
- E** Effort

\* See Building Instructions for help

### What class of lever is it?

Are your tweezers a 1st, 2nd, or 3rd class lever? Use these clues:

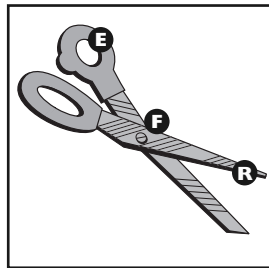

1st class

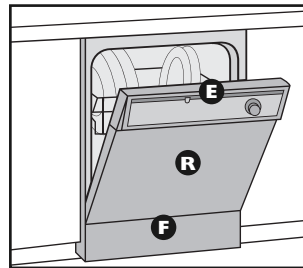

2nd class

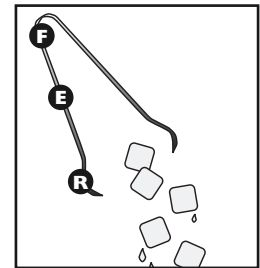

3rd class

## Student Challenge

- 1 Grip your K'NEX Tweezers near the hinge and squeeze. Can you make the tips touch? Now grip the Tweezers closer to the tips and squeeze again. Try to pick up something light, like a piece of paper. Which grip makes it easier to do this? Is this the same grip that lets you squeeze tighter?
- 2 When do you get the highest Mechanical Advantage, when you squeeze the Tweezers near the hinge or near the tips? (Refer to the "What's the Mechanical Advantage" Reference Sheet.)
- 3 Make a huge tweezers by taping together two rulers or meter/ yardsticks with heavy tape. Use your new tool to gently pick up an inflated balloon. Try to make large K'NEX Tweezers that work the same way. How does the size of the tweezers affect the way they work and their Mechanical Advantage? (Refer to the "What's the Mechanical Advantage" Reference Sheet.)

# Lever Mobile Lesson Plan

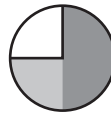
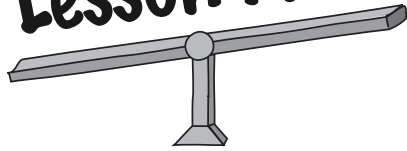

**Lesson Length:** 30-45 minutes

## Objectives

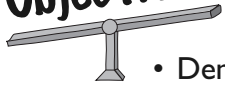

- Identify a lever from each class on the Lever Mobile
- Identify the fulcrum, resistance and effort on these levers
- Demonstrate how the Lever Mobile's components function
- Apply lever knowledge to utilize and manipulate all levers on the Lever Mobile
- Alter the Lever Mobile so levers work together to perform a single task
- Verbalize reasoning for changes to the Lever Mobile
- Design another machine that utilizes all classes of levers
- Enhance presentation skills through descriptive language

## Materials

- 12 blank dot stickers or pieces of masking tape
- marker
- classroom objects for Lever Mobile to lift and move
- extra K'NEX pieces

## Every lever has a job to do

Students should describe construction machines they have seen. They might use reference materials, like books or the Internet, to find pictures of machines that have working parts like those in the Lever Mobile.

### What class of lever is it?

The Lever Mobile has a lever in every class.

- The lifter is a 1st-class lever.
- Each door is a 2nd-class lever.
- The backhoe-scoop is a 3rd-class lever.

Direct students to the "Student Reference Sheets".

## Journal Check

- ✓ List of possible jobs performed by Lever Mobile
- ✓ Explanation of the function of one of each class of lever in the Lever Mobile
- ✓ Explanation of how the levers could function differently so they serve as different classes
- ✓ Explanation of modifications to Lever Mobile

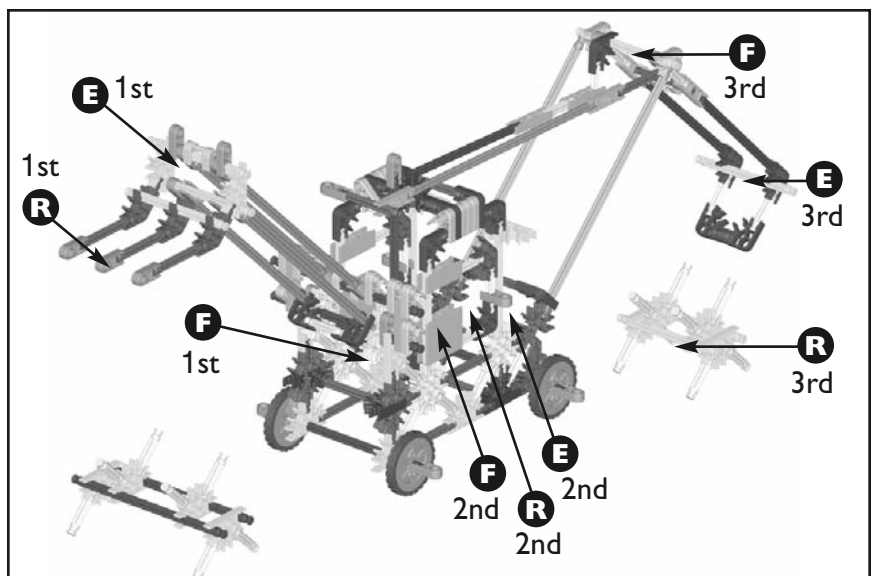

## Student Challenge

### QUESTIONS

- 1 Make a list of five jobs to do with the Lever Mobile. Then, put its levers to work! Set up some objects to lift and move. You might imagine you're at a construction site, with earth to dig and lumber to lift.
- 2
  - a. Identify one lever from each class in the Lever Mobile. Explain what these levers do in the Lever Mobile and how they serve as either a 1st, 2nd or 3rd-class lever.
  - b. Can any of these levers perform different functions? If so, do they change the lever class? Explain.
- 3 Redesign the Lever Mobile so that the levers work together to complete a task. Explain the changes you made and the work that your new Lever Mobile can do.
- 4 Design a different machine which includes 1st, 2nd and 3rd-class levers. Present your machine to the class. Ask your classmates to determine: what kind of machine you made, where each lever is, which class each lever is and the jobs each performs.

### ANSWERS

- 1 Use the Lever Mobile as a culminating activity. Review what students have learned about levers and assess their understanding by seeing if they can identify the various levers within this model.
- 2 Provide the students with ample room and materials so they can be creative as they come up with ways to use their Lever Mobiles. Some students might choose to accomplish useful tasks, while others might work best with an imaginary scenario.

# The Lever Mobile

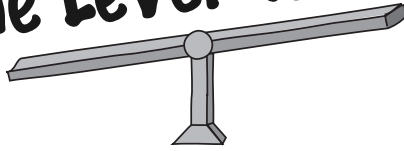

## Every lever has a job to do

Big machines use levers to dig huge holes or scoop up heavy loads. They help clear away snow, shovel dirt out to create basements for buildings and move big boxes and crates. Strong motors do the work, but levers make the work easier.



### Label your lever

Find all the levers on your Lever Mobile. Then, use stickers or tape to label the parts of each lever:

- F** Fulcrum
- R** Resistance
- E** Effort

\* See Building Instructions for help

### What class of lever is it?

Which levers on the Lever Mobile are 1st, 2nd, or 3rd class levers? Use these clues:

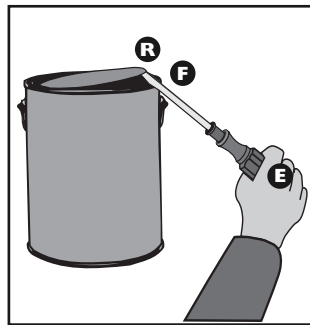

1st class

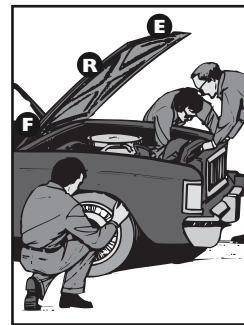

2nd class

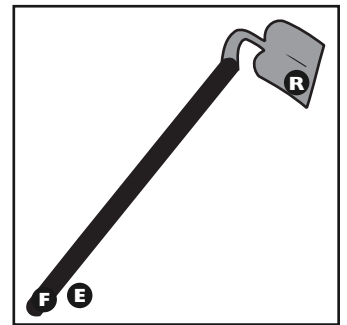

3rd class



- 1 Make a list of five jobs to do with the Lever Mobile. Then, put its levers to work! Set up some objects to lift and move. You might imagine you're at a construction site, with earth to dig and lumber to lift.
- 2 a. Identify one lever from each class in the Lever Mobile. Explain what these levers do in the Lever Mobile and how they serve as either a 1st, 2nd or 3rd-class lever.  
b. Can any of these levers perform different functions? If so, do they change the lever class? Explain.
- 3 Redesign the Lever Mobile so that the levers work together to complete a task. Explain the changes you made and the work that your new Lever Mobile can do.
- 4 Design a different machine which includes 1st, 2nd and 3rd-class levers. Present your machine to the class. Ask your classmates to determine: what kind of machine you made, where each lever is, which class each lever is and the jobs each performs.

# The Rubber Band Scale



## Materials You'll Need

- rubber band
- pencil
- tape
- string

## Make a Rubber Band Scale

- 1 Build a K'NEX Rubber Band Scale according to the instructions on the other side of this card.
- 2 Place a piece of tape on each of the tan Connectors on your Scale. Lay your Scale down so that nothing is pulling down on the Rubber Band. Find the taped tan Connector that is level with the horizontal dark gray Connector and label this Connector with a zero. This is the point where there is no force pulling on the Rubber Band.
- 3 The tan Connectors will be the measuring units on your Scale. Starting with the first Connector below your zero mark, label the Connectors 1, 2, 3 and so on.
- 4 Tie a string to the orange Connector at the bottom of the Scale.

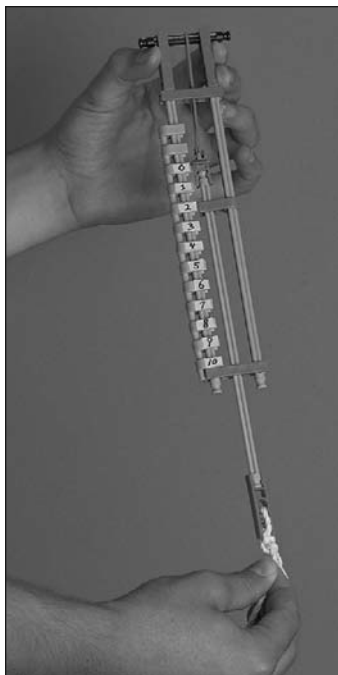
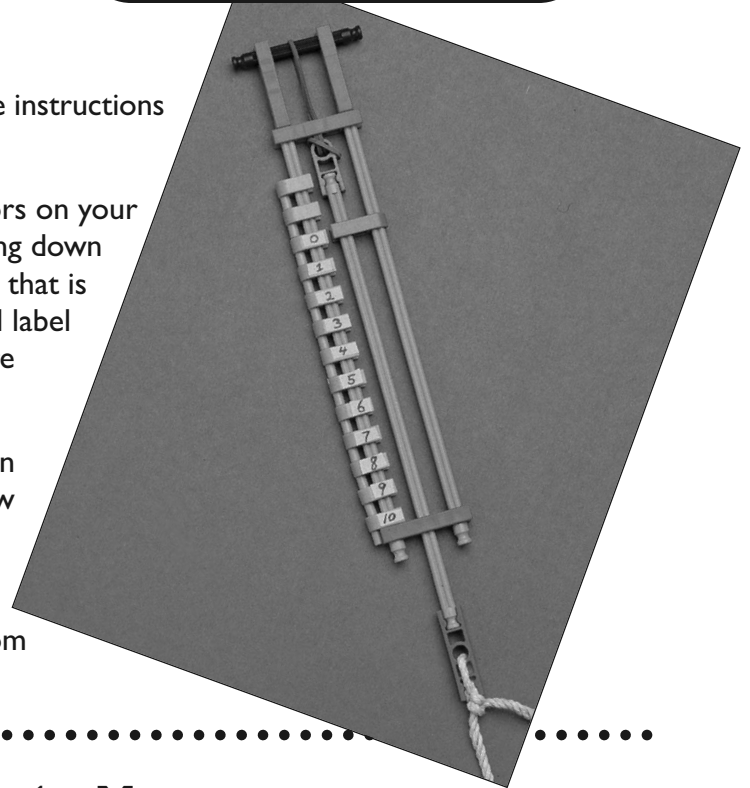

## Use Your Scale to Measure

- 1 Tie the other end of the string to the area on the object where you are applying the force.
- 2 Hold the Scale upright or upside down – whichever way stretches the Rubber Band down the Scale. Let the object pull on the cord. ***Make sure the Scale is angled away from your face.***
- 3 The horizontal dark gray Connector works as a pointer to show how much force is being applied to the machine. Read the number across from the pointer. That is your measurement.

## What Are You Measuring?

The K'NEX Rubber Band Scale measures force or weight. Its number scale does not stand for any specific unit like ounces or grams. Make up your own name for the Scale's unit of measurement.

**⚠ Safety Note: BE CAREFUL NOT TO OVERSTRETCH THE RUBBER BAND SCALE. Stretching can cause the Rubber Band to snap and cause injury. If you notice any deterioration of your Rubber Band, notify your teacher immediately.**

## Make a Rubber Band Scale

- The K'NEX Rubber Band Scale is used throughout the course of the Simple Machines Series. Its purpose is to help students gain a quantitative understanding of the relationship between simple machines, force and work.
- The Rubber Band Scale must be calibrated before use. Calibration is the “setting up” of a measuring instrument so that it gives an accurate reading. The zero mark on the Scale indicates the spot where no force is applied, so the Rubber Band has no pull on it. The Scale is numbered up from there.
- The size of the Rubber Band used for the Scale is Industrial #18.
- The Rubber Band Scale is calibrated so that the length of the Rubber Band quantifies the amount of force used to do work. The Rubber Band is extended in proportion to the force applied.
- Since Rubber Bands may not retain their original shape after repeated use, the K'NEX Rubber Band Scale may need to be recalibrated or replaced to maintain accuracy.

## Use Your Scale to Measure

- The K'NEX Rubber Band Scale measures force or weight, but its number scale does not represent ounces, grams or any other unit. Encourage students to make up their own name for their Scale's unit of measurement. They should indicate this unit in all of the Rubber Band Scale measurements.
- For more advanced students, use a spring scale calibrated in Newtons or grams. Measure the force of the weight with the spring scale and compare it to the readings from the Rubber Band Scale.
- When using the Rubber Band Scale, the readings must be within the range of measurements on the Scale. Students will need to adjust their loads so that they are heavy enough to register a reading but not so heavy that the Rubber Band is overstretched and they have a reading off the end of the Scale. Help students choose an intermediate-weight load so that the force reading falls in the middle of the Scale.
- Make sure students use the same amount of weight for each test so that readings are comparable. If the weight changes between measurements, the students may not have results that reflect the concept being investigated.
- If students try making a measurement that stretches the Rubber Band longer than the Scale, substitute a thicker Rubber Band.

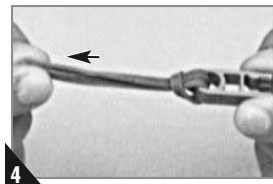
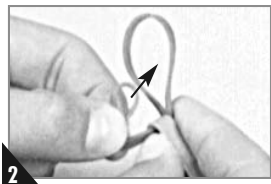
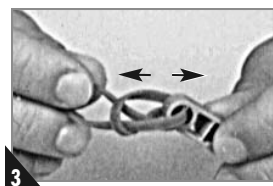
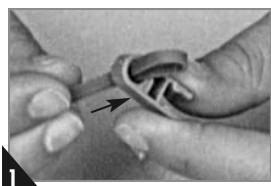

**\* Caution students not to overstretch their Rubber Bands. Overstretching can cause the Rubber Band to snap and cause personal injury. Any wear and tear or deterioration of Rubber Bands should be reported immediately to the teacher. Teachers and students should inspect Rubber Bands for deterioration before each experiment.**

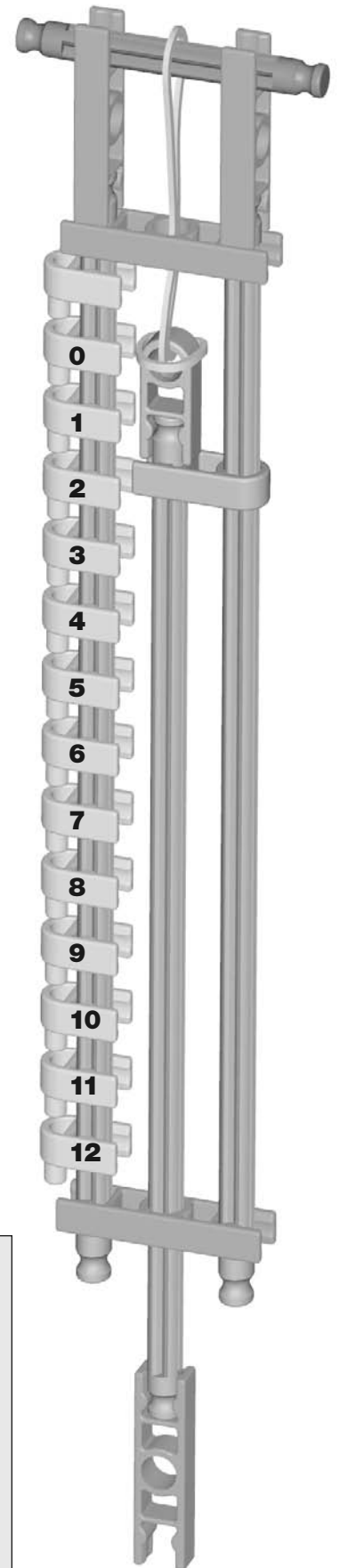

# LEVERS Part & Model List

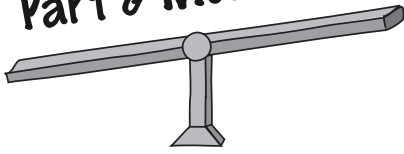

		BALANCE	SEE-SAW	2ND-CLASS LIFTER	3RD-CLASS LIFTER	CATAPULT	HANDCART	ROWBOAT	SCISSORS	DOOR	WHEELBARROW	FISHING ROD	HAMMER	TWEEZERS	LEVER MOBILE	RUBBER BAND SCALE	TOTAL PARTS IN LEVERS SET
	<b>Tan Connector</b>	0	2	2	2	0	0	0	0	0	0	1	0	0	7	14	21
	<b>Gray Connector</b>	8	2	2	2	0	2	8	2	5	2	3	2	0	30	2	34
	<b>Orange Connector</b>	8	1	0	0	3	0	9	2	0	6	3	2	0	22	5	34
	<b>Lt Gray Connector</b>	4	4	4	4	2	0	2	4	4	0	1	2	1	19	0	24
	<b>Red Connector</b>	6	2	2	2	6	2	4	0	5	2	0	2	2	21	0	23
	<b>Green Connector</b>	8	0	0	0	2	2	0	0	2	2	0	2	0	7	0	12
	<b>Yellow Connector</b>	20	4	3	3	4	0	0	2	2	5	0	2	0	19	0	37
	<b>Blue Connector</b>	4	0	0	0	0	0	0	0	2	0	0	0	0	4	0	6
	<b>White Connector</b>	4	0	0	0	0	0	0	0	0	0	2	0	0	6	0	6
	<b>Purple Connector</b>	12	0	0	0	0	0	0	0	0	0	0	0	0	8	0	12
	<b>Green Rod</b>	12	0	0	0	5	0	0	0	2	5	1	4	0	21	0	21
	<b>White Rod</b>	14	1	1	1	5	2	3	5	4	13	4	4	2	42	0	46
	<b>Blue Rod</b>	40	4	4	4	4	0	2	2	3	1	1	0	0	17	1	61
	<b>Yellow Rod</b>	22	5	5	5	5	4	6	2	6	0	0	4	0	11	0	49
	<b>Red Rod</b>	2	2	0	0	2	2	4	2	1	2	0	0	0	10	0	14
	<b>Gray Rod</b>	4	0	1	1	0	0	0	0	0	0	2	0	0	7	3	13
	<b>Sm. Tire</b>	0	0	0	0	0	2	0	0	0	1	0	0	0	4	0	4
	<b>Med. Tire</b>	2	0	0	0	0	0	0	0	0	0	0	0	0	0	0	2
	<b>Sm. Pulley</b>	0	0	0	0	0	2	0	0	0	1	1	0	0	4	0	4
	<b>Lge. Pulley</b>	2	0	0	0	0	0	0	0	0	0	0	0	0	0	0	2
	<b>Rubber Band #18</b>	0	0	0	0	0	0	0	0	0	0	0	0	0	0	1	3
<b>TOTALS PER MODEL</b>		172	27	24	24	38	18	38	21	36	40	19	24	5	259	26	428