

# KNEX<sup>®</sup> Education<sup>™</sup>

## TEACHER'S GUIDE

SIMPLE MACHINES DELUXE<sup>™</sup>  
INCLINED  
PLANES

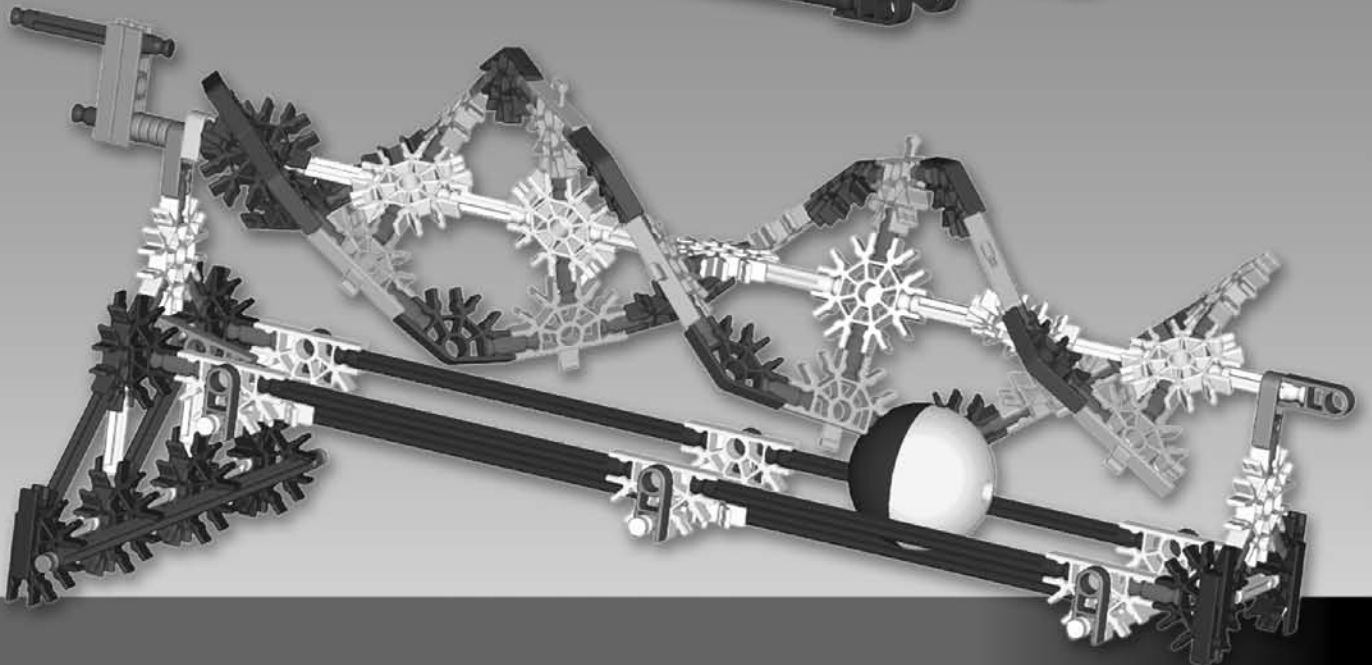
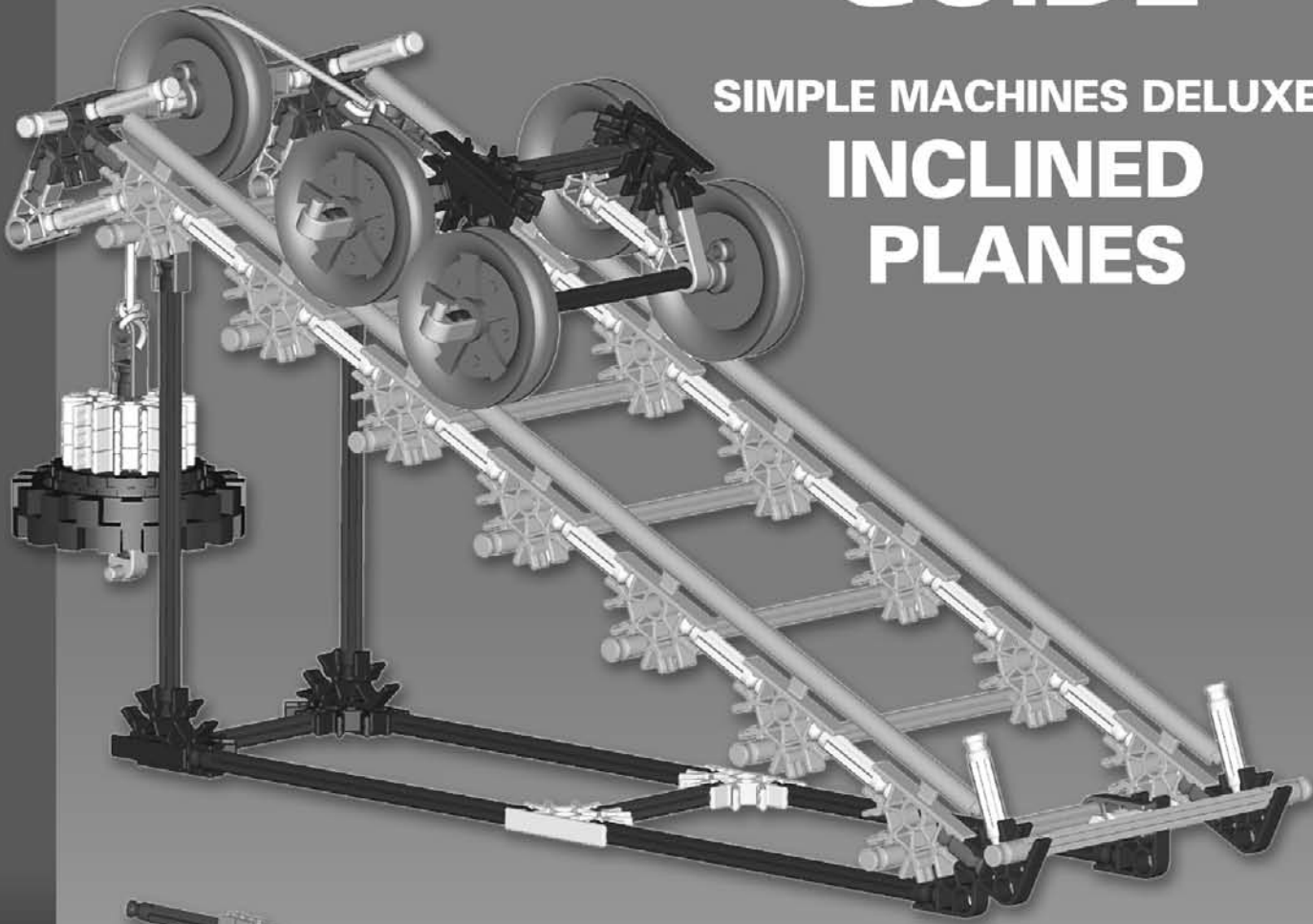

# TEACHER'S GUIDE

## SIMPLE MACHINES DELUXE™ INCLINED PLANES

KNX 79520-V1-11/10  
©2011 K'NEX Limited Partnership Group  
and its licensors.

K'NEX is a trademark of K'NEX Limited Partnership Group.

Website: [www.knexeducation.com](http://www.knexeducation.com)  
Email: [abcknex@knex.com](mailto:abcknex@knex.com)  
Phone: 1-888-ABC-KNEX (USA/CAN only)

K'NEX Limited Partnership Group  
P.O. Box 700  
Hatfield, PA 19440-0700  
USA



### **WARNING:**

CHOKING HAZARD - Small parts.  
Not for children under 3 years.



### **AVERTISSEMENT :**

DANGER D'ÉTOUFFEMENT - Pièces de petite taille.  
Ne convient pas aux enfants de moins de 3 ans.



# Table of Contents

<b>Simple Machines Deluxe Introduction</b> .....	4
<b>Standard Alignments</b> .....	5
<b>All About Inclined Planes</b>	
What is an Inclined Plane? .....	8
What is a Screw? .....	8
What is a Wedge? .....	8
Key Words and Definitions .....	8
Key Concepts .....	9
<b>Student Reference Sheets</b> .....	10
<b>Roller Coaster Ramps</b>	
Lesson Plan .....	14
Student Activity Sheet .....	16
<b>Moving Truck</b>	
Lesson Plan .....	17
Student Activity Sheet .....	19
<b>Splitting Wedge</b>	
Lesson Plan .....	20
Student Activity Sheet .....	22
<b>Chisel</b>	
Lesson Plan .....	23
Student Activity Sheet .....	25
<b>Axe</b>	
Lesson Plan .....	26
Student Activity Sheet .....	28
<b>Hand Drill</b>	
Lesson Plan .....	29
Student Activity Sheet .....	31
<b>Archimedes Screw</b>	
Lesson Plan .....	32
Student Activity Sheet .....	34
<b>Propeller</b>	
Lesson Plan .....	35
Student Activity Sheet .....	37
<b>Playground Station</b>	
Lesson Plan .....	38
Student Activity Sheet .....	40
<b>Part &amp; Model List</b> .....	41

# Introduction:

## OVERVIEW

This Teacher's Guide has been developed to support you as your students investigate the K'NEX Education Simple Machines Deluxe Set. In conjunction with the K'NEX materials and individual student journals, the information and resources here can be used to build your students' understanding of scientific concepts and channel their inquiries into active and meaningful learning experiences.

## SIMPLE MACHINES DELUXE

This K'NEX Education set is designed to introduce students to the scientific concepts associated with simple machines. Students are provided with the opportunity to acquire skills using a hands-on, inquiry based approach to information and concepts. Working cooperatively, students are encouraged to interact with each other as they build, investigate, discuss and evaluate scientific principles in action.

## TEACHER'S GUIDE

Designed as a resource for the teacher, this guide provides a glossary of key terms and definitions, includes an overview of the concepts associated with the different simple machines, identifies student objectives for each investigation, and offers plans and scripts to successfully present selected models and their associated activities. We have also provided Student Activity and Reference Sheets. These comprise illustrations and definitions of some of the concepts featured in the model building activities. Most lessons can be completed in 30 to 45 minutes. We recommend that teachers review their curriculum and science education standards to identify those activities that best support their academic needs.

## STUDENT JOURNALS

It is expected that students will have journals available for recording information. They should be encouraged to enter initial thought at the start of an inquiry – what they “think” will happen. These initial thoughts may be amended, based upon their ongoing inquiry and analysis, until the students feel comfortable about drawing conclusions. Their journal entries will help make a connection between the models they have built, the experiments they have conducted, and how this information is applied to the real-world machines they use on a regular basis. The journals will also provide students with a place to practice making drawings and diagrams of systems. Finally, the journals will serve as a method of assessment for the Simple Machines units. Journal Checklists are also included in the Teacher's Guide for each model and its associated activities.

## Alignment with National Standards Grades K-4

### The National Science Education Standards

<b>Unifying Concepts and Processes</b>	<ul style="list-style-type: none"> <li>• Systems, order, and organization</li> <li>• Evidence, models, and explanation</li> <li>• Change, constancy, and measurement</li> <li>• Form and function</li> </ul>
<b>Physical Science</b>	<ul style="list-style-type: none"> <li>• Properties of objects and materials</li> <li>• Position and motion of objects</li> </ul>
<b>Science and Technology</b>	<ul style="list-style-type: none"> <li>• Abilities of technological design</li> <li>• Understandings about science and technology</li> </ul>

Reprinted with permission from National Science Education Standards, 2001 by the National Academy of Sciences, Courtesy of the National Academies Press, Washington, D.C.

## Alignment with National Standards Grades 5 - 8

### The National Science Education Standards

<b>Unifying Concepts and Processes</b>	<ul style="list-style-type: none"> <li>• Systems, order, and organization</li> <li>• Evidence, models, and explanation</li> <li>• Change, constancy, and measurement</li> <li>• Form and function</li> </ul>
<b>Physical Science</b>	<ul style="list-style-type: none"> <li>• Motions and Forces</li> <li>• Transfer of Energy</li> </ul>
<b>Science as Inquiry</b>	<ul style="list-style-type: none"> <li>• Abilities necessary to do scientific inquiry</li> <li>• Understanding about scientific inquiry</li> </ul>
<b>Science and Technology</b>	<ul style="list-style-type: none"> <li>• Abilities of technological design</li> <li>• Understandings about science and technology</li> </ul>

Reprinted with permission from National Science Education Standards, 2001 by the National Academy of Sciences, Courtesy of the National Academies Press, Washington, D.C.

## Alignment with Standards for Technological Literacy Grades 3-5

<b>Standards for Technological Literacy</b>	
<b>The Nature of Technology</b>	<p>Core Concepts of Technology</p> <ul style="list-style-type: none"> <li>• Systems</li> <li>• Processes</li> <li>• Requirements</li> </ul> <p>Relationships among technologies</p> <ul style="list-style-type: none"> <li>• Technologies integrated</li> </ul>
<b>Design</b>	<p>The Attributes of design</p> <ul style="list-style-type: none"> <li>• Requirements of design</li> </ul> <p>Engineering Design</p> <ul style="list-style-type: none"> <li>• Engineering design process</li> <li>• Creativity and considering all ideas</li> <li>• Models</li> </ul> <p>The role of troubleshooting, research and development, invention and innovation, and experimentation in problem solving</p> <ul style="list-style-type: none"> <li>• Troubleshooting</li> <li>• Invention and innovation</li> <li>• Experimentation</li> </ul>
<b>Abilities of a Technological World</b>	<p>Apply design process</p> <ul style="list-style-type: none"> <li>• Collecting information</li> <li>• Visualize a solution</li> <li>• Test and evaluate solutions</li> <li>• Improve a design</li> </ul>

Used with permission of ITEEA ([www.iteea.org](http://www.iteea.org))

# Alignment with Standards for Technological Literacy Grades 6 - 8

## Standards for Technological Literacy

<p><b>The Nature of Technology</b></p>	<p>Core Concepts of Technology</p> <ul style="list-style-type: none"> <li>• Systems</li> <li>• Processes</li> <li>• Requirements</li> </ul> <p>Relationships among technologies</p> <ul style="list-style-type: none"> <li>• Interaction of systems</li> <li>• Knowledge from other fields of study and technology</li> </ul>
<p><b>Design</b></p>	<p>The Attributes of design</p> <ul style="list-style-type: none"> <li>• Design leads to useful products and systems</li> <li>• There is no perfect design</li> </ul> <p>Engineering Design</p> <ul style="list-style-type: none"> <li>• Brainstorming</li> <li>• Modeling, testing, evaluating, and modifying</li> </ul> <p>The role of troubleshooting, research and development, invention and innovation, and experimentation in problem solving</p> <ul style="list-style-type: none"> <li>• Troubleshooting</li> <li>• Invention and innovation</li> <li>• Experimentation</li> </ul>
<p><b>Abilities of a Technological World</b></p>	<p>Apply design process</p> <ul style="list-style-type: none"> <li>• Identify criteria and constraints</li> <li>• Test and evaluate</li> <li>• Make a product or system</li> </ul>

Used with permission of ITEEA ([www.iteea.org](http://www.iteea.org))

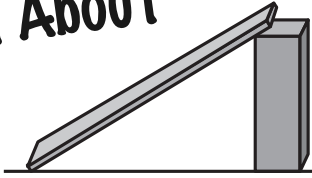

# INCLINED PLANES

## What is an Inclined Plane?

- An inclined plane is a sloped flat surface which may or may not be smooth.
- A person or object can be moved up or down the inclined plane.
- Inclined planes can change the amount of force needed to do work, the direction of the applied forces and the distance over which the force is applied.

## What is a Screw?

- A screw is a rod (called the body) with an inclined plane spiraling around it.
- A screw usually has the shape of a cylinder or narrow cone.
- The spiraling inclined plane forms ridges around the body which are called the threads of the screw.
- Some screws move objects along the threads while others twist in a spiraling motion to move through different materials.
- Screws can change the amount of force needed to do a job or the distance over which the force is applied.

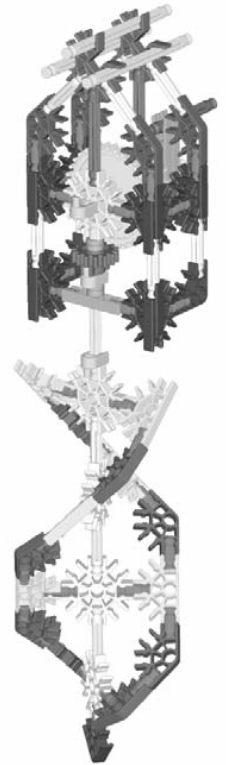

## What is a Wedge?

- A wedge is a special kind of inclined plane made of two flat slopes, back to back.
- Wedges can be used to move objects apart.
- Wedges can change the direction of the applied force; however, the forces involved in using a wedge are not always equal.

## Key Words and Definitions

**Effort**- the force that is applied to do work; the push, pull, squeeze or lift provided to use an inclined plane, screw or wedge on an object

**Resistance**- the force provided by the object on which one is trying to do work; the object works against (pushes back) the effort

**Mechanical Advantage (MA)**- a mathematical calculation that reveals how many times easier a job is to do when an inclined plane, screw or wedge is used;  
**slope length ÷ slope height = MA**

**Work**- the job being done while using the inclined plane, screw or wedge

**Load**- the object (weight) lifted or moved; provides resistance to the inclined plane, screw or wedge

**Force**- any kind of push or pull applied to an object

**Friction**- force resulting from one surface rubbing against another as an object moves

**Slope**- measure of the steepness of an incline

**Hypotenuse**- longest side of a right triangle; also the side opposite the right angle

## Key Concepts

### How does an inclined plane help you?

- Inclined planes make work easier because they reduce the amount of force needed to move an object.
- The force must be applied over a longer distance than if the object were moved straight up or down.
- Objects move along the slope rather than the machine doing the moving.

### How does a screw help you?

- Screws make work easier by changing either the amount of effort needed to do a job or the distance covered.
- The distance around the threads of the screw is longer than the length of the screw from top to bottom.
- Traveling the distance around the threads of the screw (e.g. on a spiral staircase) is easier than traveling straight up or through (e.g. using a screw to make a hole in wood).

### How does a wedge help you?

- Wedges change the direction of the applied force; when pushing down on the wedge, the object it's pushing against moves sideways.
- The direction of the two forces are at right angles to each other and are not always equal.
- The effort needed to do a job when using a wedge is reduced but must be applied over a longer distance.
- Wedges are the only inclined planes that do the moving when being used.

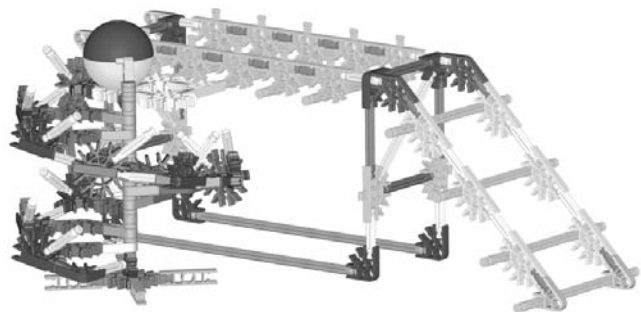

## REMEMBER

**The longer the slope of the inclined plane, screw or wedge, the easier the job is.**

## Getting Started with Inclined Planes

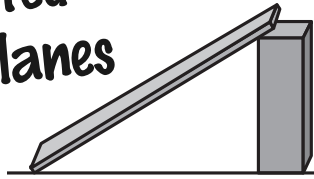

### What is an inclined plane?

- It's a flat surface with one end higher than the other.
- You can use an inclined plane to move yourself or an object up or down.
- Inclined planes can make work easier. You use less effort to move an object, although you have to move the object over a longer distance.



### How does an inclined plane help you?

This machine makes work easier. When you move an object up or down an inclined plane, you travel a longer distance than if you moved the object straight up or down. However, you don't need to supply as much effort as you would without the inclined plane. Either way, you do the same amount of work but the reduced effort makes the job easier.

### Here's an example of how inclined planes can help.

Imagine that your very best friend moved away. You live in Tree Top Village and your friend moved to another town on the other side of the Tree Top Mountains. You were invited to visit for the weekend. The mountains run the whole length of your town and you're allowed to go but you must walk there.

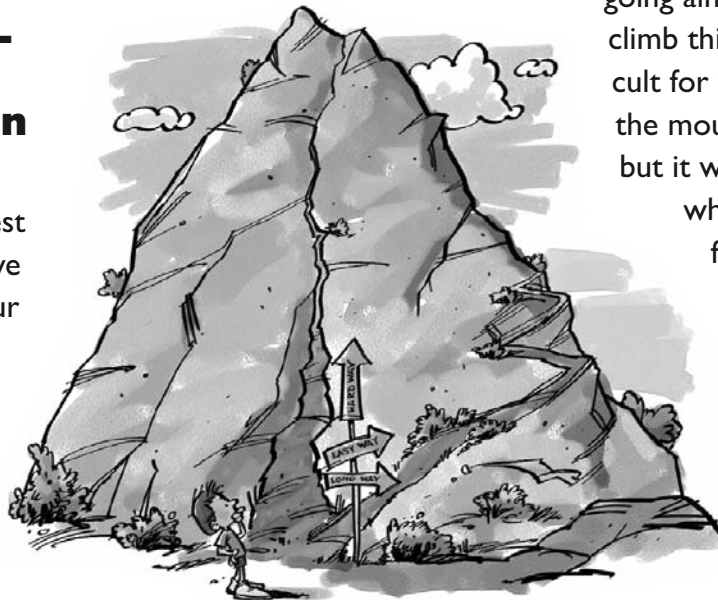

### Picture this.

The mountain is an inclined plane so you have a few options for how to get to your friend's house. You can travel straight up the Tree Top Mountains along a steep path, take a longer path over the mountain on a gentler climb or go a long way around the mountain. Which would you choose? Why?

The mountain is very tall and the hill is steep going almost straight up. If you climb this, it will be very difficult for you. Walking around the mountain will be easier but it will take almost a whole day to get to your friend's house.

However, if you walk up a gentle mountain path your journey will be easier and take less time. Is this what you decided? If not, would you choose differently now?

# What's the Mechanical Advantage?

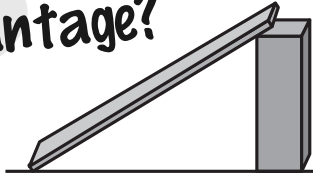

## How much does an inclined plane, screw or wedge help you?

Do some measuring and dividing to find out.

- 1 Every inclined plane, screw and wedge has a sloping surface. Measure the distance from one end of the slope to the other. (If you're measuring a screw, you'll have to go around it.) This distance is your slope's **length**.
- 2 Next, measure the distance straight up from the ground to the top of the slope. (If you're measuring a screw, find the screw's length. If you're measuring a wedge, find its thickness.) This distance is your slope's **height**.
- 3 Divide the length by the height to find the **Mechanical Advantage (MA)**.



$$\text{MA} = \text{Slope length} \div \text{Slope height}$$

The MA tells you how much easier your job is when you use an inclined plane, screw or wedge, as well as how much more distance you cover.



### Student Challenge

Imagine you want to reach the **top** of a rocky bluff. You can get there by hiking along a sloping path up a hill.

The length of the path is 1.8 kilometers, which equals 1,800 meters. The height of the bluff is 150 meters. Divide the length by the height to find the Mechanical Advantage.

$$\text{MA} = 1800 \div 150$$

$$\text{MA} = 12$$

The Mechanical Advantage is 12. This means that it's 12 times easier to climb the long path than it is to try to scale the bluff going straight up! The longer the slope, the easier the job.



# Getting Started with Screws

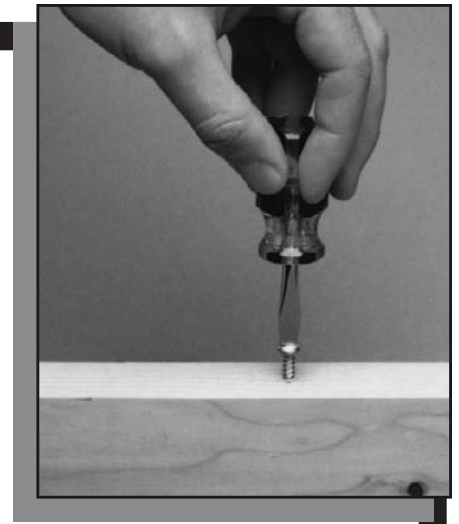
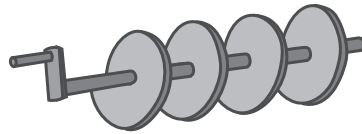

## What is a screw?

- A screw is a rod with an inclined plane spiraling around it.
- The rod is called the body of the screw. It might have the shape of a cylinder or a narrow cone.
- The spiraling inclined plane forms ridges around the body. These ridges are called the threads of the screw.
- Some screws move objects in a spiral along their threads.
- Other screws twist in a spiraling motion as they move through different kinds of materials.

## How does a screw help you?

Like all simple machines, a screw lets you do work by changing the amount of effort or distance you need to do a job. The distance around the threads of a screw is much longer than the length of the screw top to bottom, but it requires less effort to cover that distance.

## Here's an example of how screws can help.

When you turn the handle on a vise, you make the screws in the vise turn around and move deeper into the metal block that holds them. This movement makes the jaws of the vise move together. You have to do a lot of turning, and the screw threads travel a long distance, going round and round. Slowly, the jaws of the vise grip a block of wood tightly. Without the screws in the vise, you would have to push the jaws together. You wouldn't have to push far, but it would be difficult to push with enough strength to secure the wood.

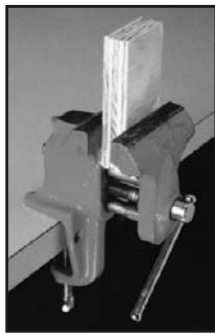

## Picture this.

You are visiting the Statue of Liberty. If you had to climb to the top of her crown on a ladder, it would be exhausting and dangerous. So, engineers built a circular staircase. The climb to the top takes longer but it's much easier and therefore more enjoyable for those visiting this historic landmark.

## A Bright Idea!

One very famous type of screw was designed long ago. This machine was needed to bring water (which is very heavy) for villagers to use from a river far away from their town. The amount of force needed to turn this giant and unique screw is small compared to the force needed to overcome the weight of the water while bringing it up to the town. Research to find the name of this famous screw, the inventor and more about it.

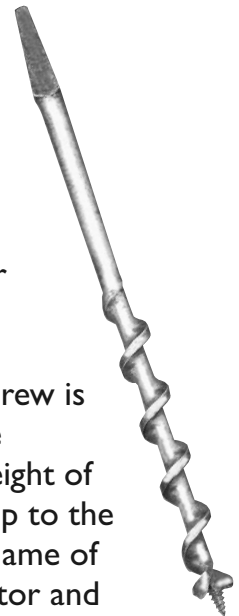

## Getting Started with Wedges

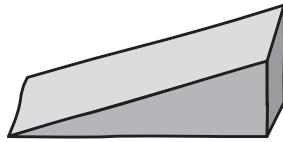

### What is a wedge?

- A wedge is a special kind of inclined plane made of two flat slopes, back to back.
- Wedges can help you move objects apart.
- A wedge can change the direction of your force: when you push down, the wedge makes the object it's pushing against move sideways.
- The forces involved in using a wedge are not always equal.

### How does a wedge help you?

When you use most types of inclined planes, the objects move across the surface of the inclined plane. However, a wedge is an inclined plane that does the moving when you use it. The wedge lets you use less effort to move objects apart, but you have to cover a greater distance to do it.

### Here's an example of how wedges can help.

Most wedges or combinations of wedges are used for cutting. Although scissors, shears, axes and knives are levers—these levers are combined with wedges. The wedges enhance the upward and downward movement of the levers and turn them into machines which cut and separate as they move up and down.

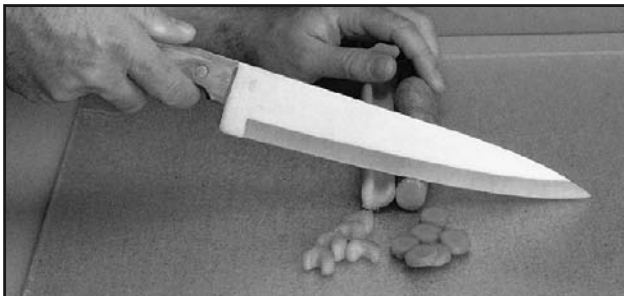

### Picture this.

When you push a knife into a carrot, the carrot moves along the sloping sides of the knife.

Which is greater—the distance the carrot traveled along the blade of the knife or the distance the two pieces of carrot moved apart after the cut was made? The carrot traveling along the blade moves a greater distance BUT you don't have to provide as much effort to separate the carrot into two pieces as you would without the knife.

### A Bright Idea!

It may be hard to think about a wedge as a simple machine which does work. For example, a door jamb is a wedge which does work but is difficult to see. It looks like an inclined plane but it serves a different purpose. Can you determine how and why a door jamb functions as this type of simple machine?

# The Roller Coaster Ramps Lesson Plan

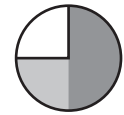
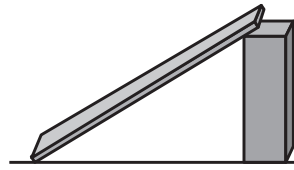

**Lesson Length:** 30-45 minutes

## Objectives

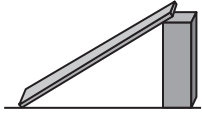

- Understand what an inclined plane is and how it does work
- Demonstrate how roller coaster ramps function as inclined planes
- Determine how height and length affect the work done by inclined planes
- Identify the advantages and disadvantages of using inclined planes
- Measure forces with a Rubber Band Scale
- Investigate the effects of friction and gravity on inclined planes

## Materials

- small cup
- poster board
- ruler
- scissors
- waxed paper
- sandpaper
- small objects, such as paper clips, chalk, pennies, pebbles and erasers
- K'NEX Rubber Band Scale

## Every inclined plane has a job to do

Recall what it feels like to travel on the different ramps of a roller coaster. The motor pulls hard as the car travels slowly up the first big hill. The long ramp actually makes the motor's job easier—not harder. Hauling cars up a slope takes less force than lifting the cars straight up. The steep incline gives a wild and exciting ride and also prevents the car from going too fast. If the car dropped straight to the ground, it would go even faster. The slope down and/or around actually slows it down.

## Journal Check

- ✓ Description of Roller Coaster Ramp heights & lengths
- ✓ Rubber Band Scale measurements for force
- ✓ Description of the effects of friction, height and length on objects traveling on inclined planes

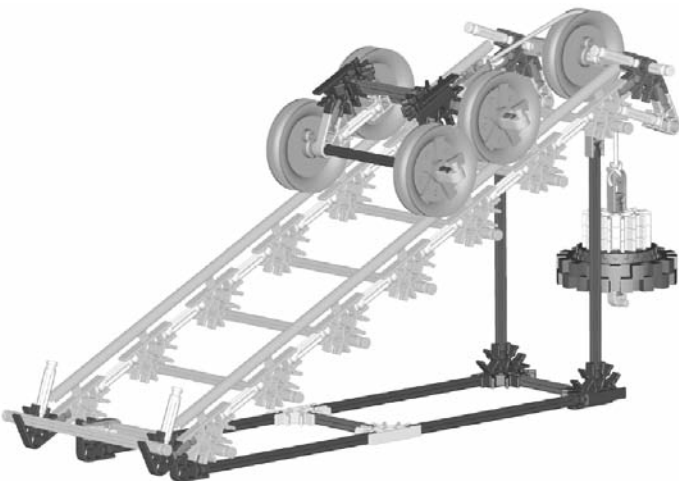

## QUESTIONS

- 1 Set your two K'NEX Roller Coaster Ramps side by side on a table. What do you notice about the heights and lengths of the Ramps? Write a description comparing them.
- 2
  - a. Place the Roller Coaster Ramps with the backs (top of the incline) at the edge of the table. Hold your car at the bottom of the longer Ramp. Run its string over the Pulley at the top of the Ramp, so the weight hangs down over the back of the Ramp. Let the car go. What happens? Now try the same thing with the steep Ramp. Which Ramp does the car go up easier/faster? Why?
  - b. Build and use a K'NEX Rubber Band Scale to measure how much force it takes to pull the car up each Ramp. First, remove the weight from the string and attach the Scale in its place. Place a cup of pennies or pebbles on the front half of the car to weigh it down. Then, use the Scale to pull the car up the Ramp. Check the reading on the Scale. How do your readings differ for the two Ramps? What does this explain about how the height of an inclined plane affects the work done?
- 3
  - a. Try making your Roller Coaster Ramps into sliding boards. Cut two pieces of stiff paper or cardboard, each about 9 x 22cm. Place one piece on each Ramp to make a smooth sliding surface. The long Ramp will not be completely covered, but you will have two slides of the same length.
  - b. Now, race small objects, like pennies or paperclips, down the slides. Which slide is faster? Why? Try objects with other textures, such as pencil erasers or marbles. Discuss your findings.
  - c. Next, replace the cardboard with sand paper and see how your results are affected. Summarize your experiments and what you discovered in a short paragraph.

## ANSWERS

- 1 The two Roller Coaster Ramps are exactly the same height. When a car goes up these ramps, it travels a greater distance on the long ramp, covering a longer horizontal span, but it reaches the same height.
- 2
  - a. The weight (being pulled down by gravity) can easily pull the car up the gradual climb on the longer ramp. In contrast, the car stays at the bottom of the steep ramp because the weight doesn't provide enough force to pull the car up.
  - b. When students use the K'NEX Rubber Band Scale, help them add enough weight to the car to allow the Scale to register. Make sure the weight is the same for each ramp. They should find that the steep ramp registers a higher reading on the Rubber Band Scale, which means that it takes more force to pull the car up this ramp.  
If the ramps were hills, the long one would be easier to climb, because you don't travel as far up with each step. However, you have to take more steps. The steep hill requires fewer steps, but each step is harder to take. Emphasize to students that the amount of work you do — reaching the top of either hill — remains the same but the amount of force to reach the top differs. Use the "What's the Mechanical Advantage?" Reference Card to help students understand this concept.
- 3
  - a. By turning the ramps into slides, students see that the steeper the slope, the faster an object will slide down it. The difference in both the length and height of the incline combined with the surface of both the incline and the object traveling over it are variables which directly affect the results.  
Gravity pulls the object down each slope, but the steeper slope has less distance and surface area top to bottom. Therefore, there is less room for friction to affect the object. The more friction, the slower the object will move. Objects like an eraser may not move down the long slope at all, and even a marble may not travel down a steep sandpaper slope.

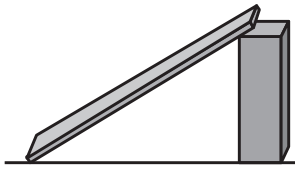

# The Roller Coaster Ramps



## Every inclined plane has a job to do

A roller coaster is made of many inclined planes, and that's what makes it fun to ride! The long, low slope of the first ramp makes it easy for a motor to pull up the cars loaded with people. When you reach the top, you zoom down a steep ramp at high speed. The ramp is just steep enough to give you a wild, but safe ride. You have enough speed to climb the next uphill ramp, so you can race downhill again. The ramps are arranged in just the right way to give you a thrilling ride.

### Student Challenge

- 1 Set your two K'NEX Roller Coaster Ramps side by side on a table. What do you notice about the heights and lengths of the Ramps? Write a description comparing them.
- 2
  - a. Place the Roller Coaster Ramps with the backs (top of the incline) at the edge of the table. Hold your car at the bottom of the longer Ramp. Run its string over the Pulley at the top of the Ramp, so the weight hangs down over the back of the Ramp. Let the car go. What happens? Now try the same thing with the steep Ramp. Which Ramp does the car go up easier/faster? Why?
  - b. Build and use a K'NEX Rubber Band Scale to measure how much force it takes to pull the car up each Ramp. First, remove the weight from the string and attach the Scale in its place. Place a cup of pennies or pebbles on the front half of the car to weigh it down. Then, use the Scale to pull the car up the Ramp. Check the reading on the Scale. How do your readings differ for the two Ramps? What does this explain about how the height of an inclined plane affects the work done?
- 3
  - a. Try making your Roller Coaster Ramps into sliding boards. Cut two pieces of stiff paper or cardboard, each about 9 x 22cm. Place one piece on each Ramp to make a smooth sliding surface. The long Ramp will not be completely covered, but you will have two slides of the same length.
  - b. Now, race small objects, like pennies or paperclips, down the slides. Which slide is faster? Why? Try objects with other textures, such as pencil erasers or marbles. Discuss your findings.
  - c. Next, replace the cardboard with sand paper and see how your results are affected. Summarize your experiments and what you discovered in a short paragraph.

# The Moving Truck Lesson Plan

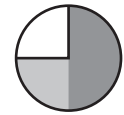
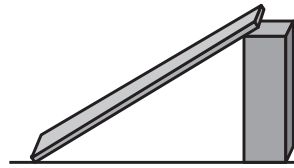

**Lesson Length:** 30-45 minutes

## Objectives

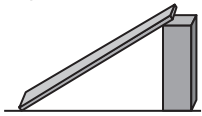

- Understand what an inclined plane is and how it does work
- Demonstrate how a moving truck ramp functions as an inclined plane

- Measure distance and force with a ruler & Rubber Band Scale respectively
- Enhance basic math skills
- Practice creative problem-solving
- Apply the concept of Mechanical Advantage to a real world situation
- Understand the relationship between a gradient incline, distance traveled and force

## Materials

- ruler
- K'NEX Rubber Band Scale
- extra K'NEX pieces

## Every inclined plane has a job to do

Many trucks are equipped with ramps that assist with loading and unloading the contents. These might be moving trucks, package or delivery trucks or landscaping trucks. Loading a truck requires a person to lift heavy objects repeatedly, so anything to make each object easier to move is a big help.

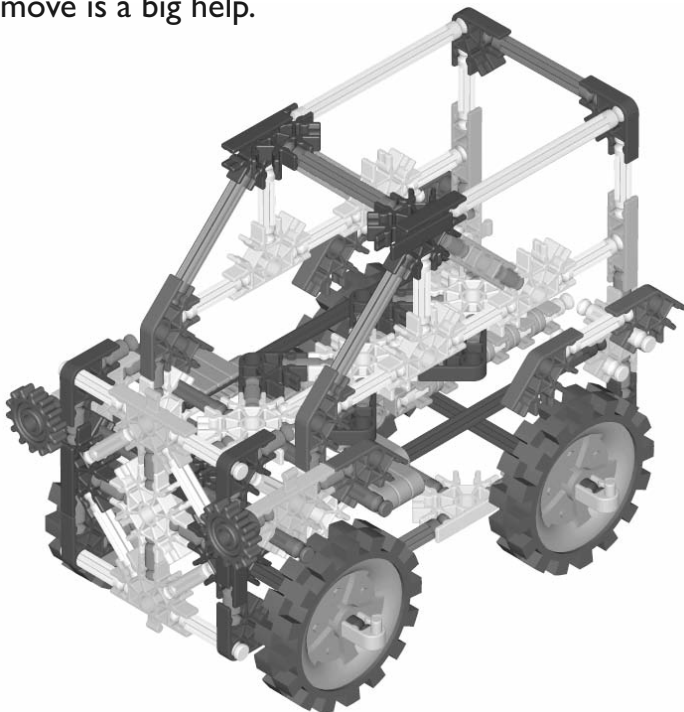

## Journal Check

- ✓ Measurement of the ramp lengths
- ✓ Math work to determine MA (ramp length divided by ramp height)
- ✓ Rubber Band Scale force measurements
- ✓ Description of the difference in the force measurements and which ramp made work easier
- ✓ Math equation and solution for orange movers
- ✓ Explanation of benefits of gradual vs steep incline
- ✓ List of things which use inclined planes and a description of how they help

## QUESTIONS

- 1
  - a. Use a ruler to measure the distance from the ground to the top of the ramp on the Moving Truck. Then measure the length of the ramp itself. Divide the ramp length by the ramp height. How do the measurements compare? How many times longer is the ramp than it is high?
  - b. Measure the amount of force used to move an object up the Truck Ramp. Connect the K'NEX Rubber Band Scale to an object and pull it up the ramp. Record your results.
  - c. Find out how much easier it is to use the ramp to load a box into the truck, compared to lifting the box from the ground up into the truck. (Use the "What's the Mechanical Advantage?" Reference Sheet for help.) Make the ramp longer and again determine how much easier it is to load something onto the truck with the ramp.
  - d. Use the Scale to measure the force used with this ramp and record your results. Compare the results from both experiments. Which ramp made the work easier? Why?
- 2
  - a. Imagine you were small enough to drive the K'NEX Moving Truck, and that you had to load 100 boxes of oranges by hand, one at a time. How much farther would you have to move each box when you carry it up the ramp, compared to lifting it up from the ground? For 100 boxes, what would the total extra distance be?
  - b. Carrying all those boxes up the ramp means moving a longer distance. But, you use less effort compared with lifting the boxes straight up. What benefits are there to moving the extra distance in order to reduce the effort you use? Explain.
- 3
  - List other examples of ramps that make it easier to move heavy things. Explain how they help.

## ANSWERS

- 1
  - a. Students should find that the top of the ramp is about 7.5 cm above the ground, and the ramp is about 15 cm long. They should divide 15 by 7.5 to find that the ramp is about two times as long as it is high.
  - b. Students will find that the Mechanical Advantage equals 2. That means that using the ramp makes the job twice as easy. Another way to describe the Mechanical Advantage of this ramp is that half the effort (or force) is needed to lift a load.
  - d. The ramp with the longer, more gradual incline made the work easier. However, the tradeoff for the work being easier is that it takes longer to accomplish.
- 2
  - a. For students to determine how much farther they move when carrying a load up the ramp, they should subtract the ramp's height from its length (for example:  $15 - 7.5 = 7.5$  cm). To move 100 boxes, the total extra distance would be determined by multiplying the extra distance for one trip by 100 ( $7.5 \times 100 = 750$  cm).
  - b. Opinions will differ regarding the value in traveling farther to reduce the effort to load boxes onto the truck. Emphasize that the amount of work being done remains constant. Like any simple machine, the Moving Truck Ramp just changes the way you do the work, by using more or less force or distance.
- 3
  - Suggest students mentally "walk around" their school, home, local stores, parks or anywhere else that objects might be moved up. Such objects might include cars, bikes or their own bodies. Examples of ramps include: stairs, ladders, sidewalk cutaway ramps, wheelchair ramps, winding mountain roads and even ramps used to build ancient pyramids.

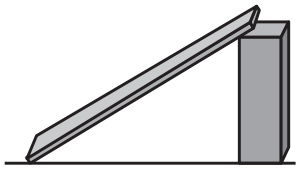

# The Moving Truck

## Every inclined plane has a job to do

A moving truck can hold a houseful of furniture. To load the truck, people have to move the tables, chairs, beds and desks one by one. It's a lot of work and each piece of furniture is heavy. The truck has a ramp that the movers can walk up and down with the furniture. The ramp makes this job easier than lifting the furniture onto the truck from the ground.



### Student Challenge

- 1
  - a. Use a ruler to measure the distance from the ground to the top of the ramp on the Moving Truck. Then measure the length of the ramp itself. Divide the ramp length by the ramp height. How do the measurements compare? How many times longer is the ramp than it is high?
  - b. Measure the amount of force used to move an object up the Truck Ramp. Connect the K'NEX Rubber Band Scale to an object and pull it up the ramp. Record your results.
  - c. Find out how much easier it is to use the ramp to load a box into the truck, compared to lifting the box from the ground up into the truck. (*Use the "What's the Mechanical Advantage?" Reference Sheet for help.*) Make the ramp longer and again determine how much easier it is to load something onto the truck with the ramp.
  - d. Use the Scale to measure the force used with this ramp and record your results. Compare the results from both experiments. Which ramp made the work easier? Why?
- 2
  - a. Imagine you were small enough to drive the K'NEX Moving Truck, and that you had to load 100 boxes of oranges by hand, one at a time. How much farther would you have to move each box when you carry it up the ramp, compared to lifting it up from the ground? For 100 boxes, what would the total extra distance be?
  - b. Carrying all those boxes up the ramp means moving a longer distance. But, you use less effort compared with lifting the boxes straight up. What benefits are there to moving the extra distance in order to reduce the effort you use? Explain.
- 3
  - a. List other examples of ramps that make it easier to move heavy things. Explain how they help.

# The Splitting Wedge Lesson Plan

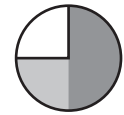
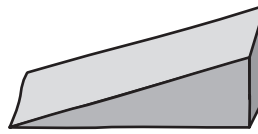

**Lesson Length:** 30-45 minutes

## Objectives

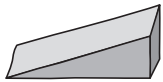

- Understand what a wedge is and how it does work
- Demonstrate how a splitting wedge functions as a wedge
- Identify the similarities between a splitting wedge and a knife
- Measure distance with a ruler
- Learn about Abraham Lincoln and his involvement with railsplitting
- Determine how wedges help do work in everyday life

## Materials

- ruler
- stack of books

## Every wedge has a job to do

A wedge can successfully split a log since the lengthwise grain of the wood makes it easy for the log to break apart as the wedge widens a crack. A carrot will break in the same way when cut with a knife since the knife is a wedge too. The splitting wedge is also a lever and the log being split provides the resistance.

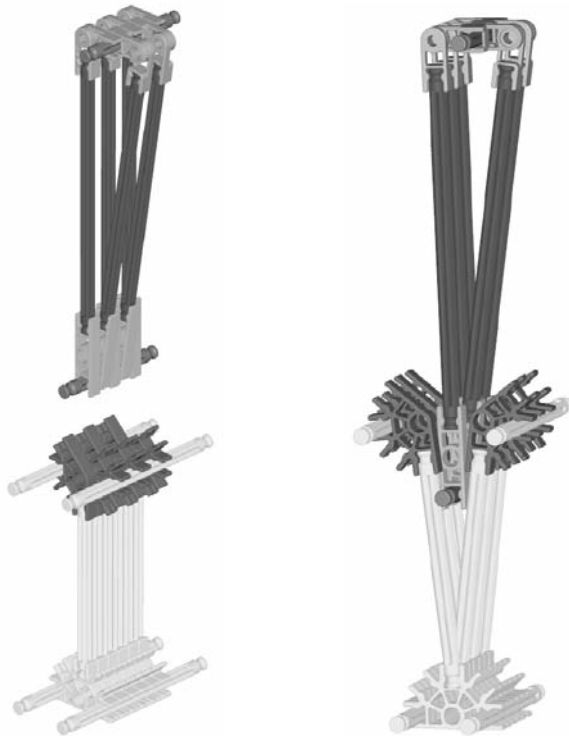

## Journal Check

- ✓ Distance measurements
- ✓ Diagram of the direction work is performed with labels for distance and direction
- ✓ Description of the direction wedges do work
- ✓ Explanation of the history of “Railsplitter” Abe Lincoln
- ✓ List and uses of everyday wedges

## QUESTIONS

- 1 Set the point of your K'NEX Splitting Wedge between the green Connectors of the Log. Push the Wedge down a short way. How much do the halves of the Log separate? Measure the distance between the green Connectors. Now push the Wedge in farther and measure again. Draw a diagram to show which directions the Wedge and the halves of the Log move. Label your diagram to show how far they move.
- 2 Make a stack of books and use your Splitting Wedge to open a crack between two books. When you tap the Wedge in, which way do the books go? Explain how a wedge works as a moving inclined plane. (*Hint: You can move heavy things up an inclined plane. Think about what moves up when you use a wedge.*)
- 3 Using wedges, Abraham Lincoln earned himself a nickname – “The Railsplitter.” Find out how he got this name and how he used wedges.
- 4 What are other uses for wedges besides splitting wood? Work with a partner to brainstorm a list of uses for wedges.

## ANSWERS

- 1 By using the Splitting Wedge to split the Log, students should see that the farther you push down the Wedge, the farther apart the Log separates. The Wedge moves down, but the halves of the Log move sideways. Their drawings should show that the Wedge can make the Log's green Connectors separate a greater distance than just the width of the Wedge's tip.
- 2 When students use the Wedge to split a stack of books, the books on top move up when the Wedge is tapped into the stack. Guide students to explain that a wedge, like a basic inclined plane, can move things up, but instead of the object moving up the slope, the slope (wedge) is moving under the object, lifting it up.
- 3 Students should use a variety of mediums to research the life of Abraham Lincoln. When Lincoln was a boy, he helped his father clear land in the wooded area where they lived in Indiana. He was big for his age, so even at age eight he was able to use an axe (one kind of wedge) to cut trees. Later, as a teenager and young man, he worked for others chopping firewood for heating and cooking, cutting logs for houses and splitting rails for fences and cabins. To split a log into rails or planks, he would drive a wedge into a crack in the log. He was given the name “The Railsplitter” at the Illinois State Republican Convention in 1860. This name reminded people of his earlier years, and it helped voters feel good about him.
- 4 Wedges are used to keep doors open (door jambs); and they are used as shims by carpenters doing different kinds of woodwork. In San Francisco, people park their vehicles using their emergency brake because the hills there are extremely steep. To further reinforce the emergency brake, drivers place wedges behind the tires to keep the car from rolling backwards.

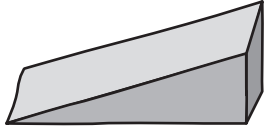

# The Splitting Wedge

## Every wedge has a job to do

To split firewood into smaller pieces, you could use a wedge like this one. The wedge fits into a crack in a log. You hammer the splitting wedge down into the crack, and the wood on either side of the wedge moves apart. The farther you push in the wedge, the bigger the crack gets, until the log breaks in two.

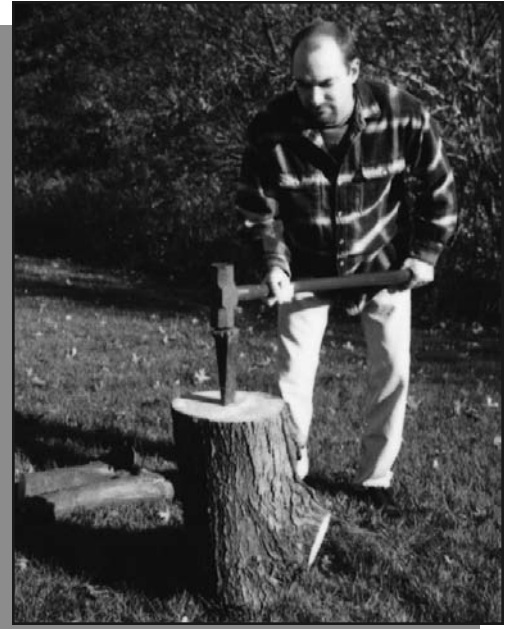

## Student Challenge

- 1 Set the point of your K'NEX Splitting Wedge between the green Connectors of the Log. Push the Wedge down a short way. How much do the halves of the Log separate? Measure the distance between the green Connectors. Now push the Wedge in farther and measure again. Draw a diagram to show which directions the Wedge and the halves of the Log move. Label your diagram to show how far they move.
- 2 Make a stack of books and use your Splitting Wedge to open a crack between two books. When you tap the Wedge in, which way do the books go? Explain how a wedge works as a moving inclined plane. (*Hint: You can move heavy things up an inclined plane. Think about what moves up when you use a wedge.*)
- 3 Using wedges, Abraham Lincoln earned himself a nickname – “The Railsplitter.” Find out how he got this name and how he used wedges.
- 4 What are other uses for wedges besides splitting wood? Work with a partner to brainstorm a list of uses for wedges.

# The Chisel Lesson Plan

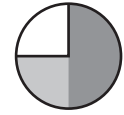
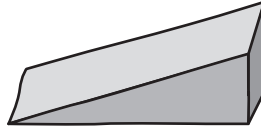

**Lesson Length:** 30-45 minutes

## Objectives

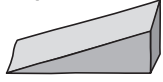

- Understand what a wedge is and how it does work
- Demonstrate how a chisel functions as a wedge
- Identify similarities between a chisel and a knife
- Explain how the chisel provides Mechanical Advantage
- Design and sculpt a model with the Chisel

## Materials

- block of florist's foam (fine-grained)
- small piece of cardboard (cereal box)
- tape
- scissors
- modeling clay or dough

## Every wedge has a job to do

The thin blade of a chisel allows for lean, precise cuts. Chisels can be held perpendicular to a block of wood and then tapped with a mallet to cut into the wood. By cutting along the four sides of a square, the chisel can cut a square hole. Chisels can also be used like a plane, sliding along the edge of a piece of wood, following the grain. This action will smooth off corners or rough areas.

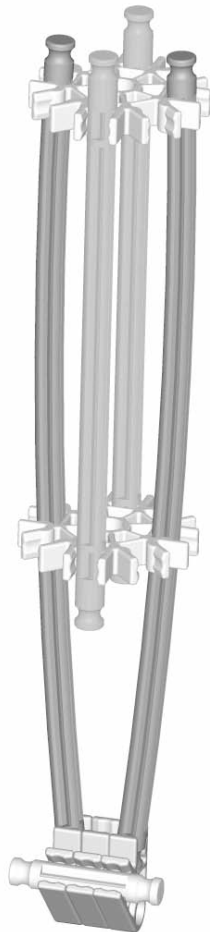

## Journal Check

- ✓ Sketch of a chisel, labeled
- ✓ Description of what is changed when a knife is converted into a chisel; particular attention should be paid to the wedge
- ✓ Sketch of clay or foam model to be sculpted using the Chisel
- ✓ Explanation as to how to sharpen a chisel and how this might affect its work
- ✓ Description of differences experienced using a dull chisel and a sharp one
- ✓ Description of any relationship between the length and sharpness of the wedge on the Chisel

## QUESTIONS

- 1 Draw a sketch of a knife and label the part that is the wedge. Change the picture of the knife into a chisel and label the part of the chisel that is a wedge. Describe what you had to change. Did the wedge change? Why or why not?
- 2 You can use your K'NEX Chisel to cut holes, smooth edges on a foam block or shape some clay or dough. Try shaping a block of foam or clay to make a sculpture or model. Before you start cutting, draw a sketch and mark your block so you'll know where to make your cuts.
- 3
  - a. Your K'NEX Chisel isn't very sharp. If you could sharpen the end, how would it change the length of the Chisel's slope? How would that change make work easier or harder? Why? Write a paragraph explaining this. (Use the "What's the Mechanical Advantage?" Reference Sheet.)
  - b. Now, try making the Chisel's tip sharper. Cut a piece of cardboard about 2 x 6 centimeters. Fold the cardboard in a V-shape and tape it over the Chisel's point.
  - c. Use this sharper Chisel to make a sculpture from a foam or clay block. Explain any differences you notice from using the "sharp" chisel. Is there a relationship between the sharpness and the width of the wedge? If so, describe it.

## ANSWERS

- 1 A chisel has a small wedge at its tip, and the rest of the tool is the blade, shaft and handle. Students' drawings should show the slope of the chisel's tip. Note that a chisel is a specialized tool, different from a knife, screwdriver or paint scraper.
- 3
  - a. Sharpening a chisel makes its slope longer. The longer the slope, the greater the Mechanical Advantage. This means that the effort needed to use the chisel is reduced. The sharper the chisel, the easier the job. Students should consider their experiences with knives, scissors and other cutting wedges they use which work better when they're sharp.
  - b. Before sculpting, use cardboard folded over the K'NEX Chisel to create a sharper chisel wedge. Be sure students refer back to their sketch to avoid simply hacking their foam or clay to pieces. Possibilities might include: a robot face, a pair of dice or a house.

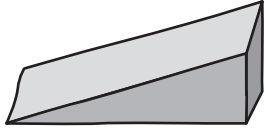

# The Chisel

## Every wedge has a job to do

A chisel is like a knife, except that its sharp blade is at its tip instead of along its side. Chisels and knives are both wedges used for cutting. Woodworkers use chisels to cut holes in a piece of wood or to shave edges down smooth.

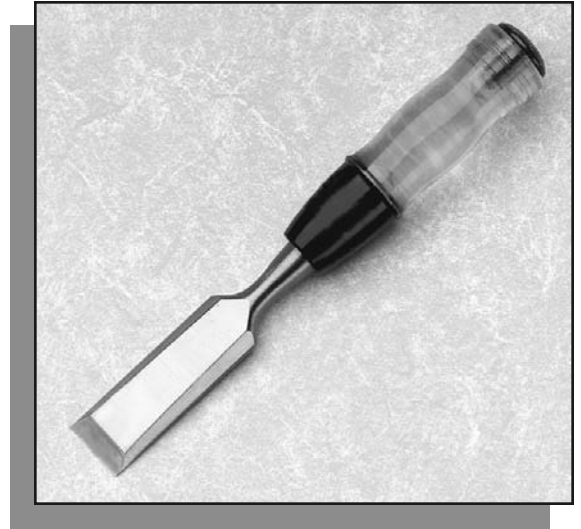

### Student Challenge

- 1 Draw a sketch of a knife and label the part that is the wedge. Change the picture of the knife into a chisel and label the part of the chisel that is a wedge. Describe what you had to change. Did the wedge change? Why or why not?
- 2 You can use your K'NEX Chisel to cut holes, smooth edges on a foam block or shape some clay or dough. Try shaping a block of foam or clay to make a sculpture or model. Before you start cutting, draw a sketch and mark your block so you'll know where to make your cuts.
- 3 a. Your K'NEX Chisel isn't very sharp. If you could sharpen the end, how would it change the length of the Chisel's slope?

How would that change make work easier or harder? Why? Write a paragraph explaining this. (Use the "What's the Mechanical Advantage?" Reference Sheet.)

b. Now, try making the Chisel's tip sharper. Cut a piece of cardboard about 2 x 6 centimeters. Fold the cardboard in a V-shape and tape it over the Chisel's point.

c. Use this sharper Chisel to make a sculpture from a foam or clay block. Explain any differences you notice from using the "sharp" chisel. Is there a relationship between the sharpness and the width of the wedge? If so, describe it.

# The Axe Lesson Plan

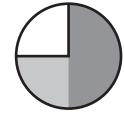
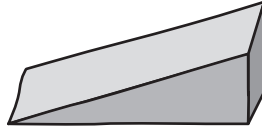

**Lesson Length:** 30-45 minutes

## Objectives

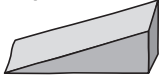

- Understand what a wedge is and how it does work
- Demonstrate how an axe functions as a wedge
- Determine how the particular shape of an axe's wedge helps it do work
- Simulate how an axe is used
- Understand the real world application of axe-like wedges in objects
- Identify early uses of wedges and axe-like tools

## Materials

- a stack of paper plates or cardboard circles (cut from corrugated boxes)
- reference materials about early humans' stone tools
- extra K'NEX pieces

## Every wedge has a job to do

An axe pushes into wood, forcing the wood apart. The axe blade is a moving inclined plane (actually a pair of inclined planes, back to back) and the wood is forced up the slopes. The wood moves a distance apart, equal to the height of the slopes. The wood that moves up the slopes breaks off the tree, producing wood chips. Moving the wood up the slopes is much easier than making the wood move apart in any other way, such as by pulling it apart. The axe incorporates another simple machine: the lever. Its long handle acts as a lever to increase the force of each swing.

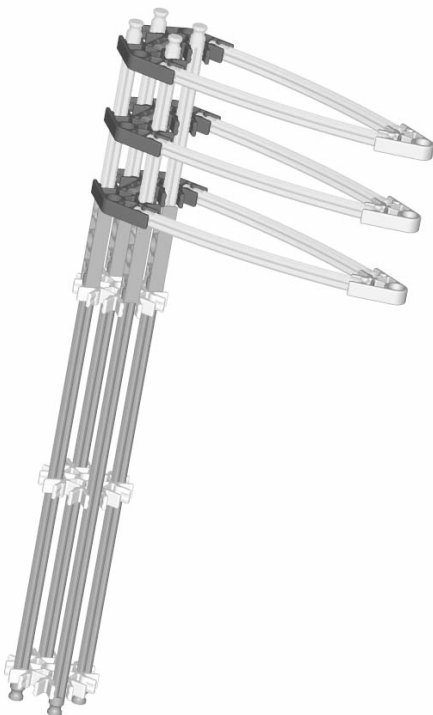

## Journal Check

- ✓ Description of what happens when chopping a paper plate tree with a K'NEX Axe
- ✓ Description of the functional difference between chopping with the Axe blade vs the wide part
- ✓ Explanation of how the wedge shape of the axe makes work easier
- ✓ List of other tools which function like an axe
- ✓ List of other tools which have the same type of wedge as an axe
- ✓ Poster with drawings, labels and descriptions of wedges used by early or prehistoric man

## QUESTIONS

- 1 a. Use a stack of paper plates or cardboard circles as a model of a tree. Then, use your K'NEX Axe to chop the tree. Describe what happens as the blade's tip hits the tree.  
b. Next, try chopping the tree using the back side of the Axe's blade – the wide part of the wedge. Try to swing the Axe with the same amount of force as you used in Step 1a. What happens? Explain how the wedge shape of an axe's blade helps make chopping wood easier.
- 2 a. What other tools can you think of that use a sharp wedge for cutting? Work with a partner to list as many examples as you can.  
b. Can you think of other examples of objects that are as sharp as an axe which have a thin wedge that broadens into a wide wedge?
- 3 Some of the first tools that early humans used were different types of wedges made from stones. Find out more about these tools: when and how they were made and how they were used. Make a poster with drawings and labels to show what you learned.  
Build a few of these tools out of K'NEX. Demonstrate how they are used.

## ANSWERS

- 1 a. When students chop their tree model, they should note that the blade slides between the plates or circles, making the stack separate.  
b. Using the back side of the blade to chop doesn't accomplish anything; the axe head just hammers against the tree. In contrast, the wedge shape helps by making the wood move up the slopes and separate into two parts.
- 2 Examples of sharp wedges used for cutting include: knife, scissors, chisel, wood plane, fingernail clippers, garden shears, paper cutter, can opener (wedge-shaped wheel), hedge trimmer, teeth (incisors) and plow. You might draw a cross-section of a knife blade on the chalkboard, to make sure that students see that the thin blade is actually a wedge, even though the wide end of the wedge doesn't have much height.
- 3 Refer students to various mediums to investigate prehistoric humans and their tools. Students may find that early humans, such as *Homo habilis* and *Homo erectus*, as well as Neanderthals, chipped the edges off stones to make sharp tools with a wedge-shaped edge.  
The tools included knives, hatchets, axes, scrapers and spearheads. They used these tools for hunting and butchering animals, cutting up plant foods, scraping animal hides and cutting wood. To shape a stone, they would strike the stone with another stone or piece of bone, making flakes and splinters break off the stone.

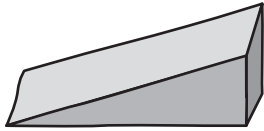

# The Axe

## Every wedge has a job to do

The blade of an axe is a wedge – a very sharp one! People use axes to cut down trees and chop wood. First, the blade's sharp edge pushes into the wood, and then the wider part of the blade makes the wood move apart. Sometimes chips of wood go flying! This wedge, with a long surface going from very sharp and thin to very wide, makes it easier to do a difficult job.

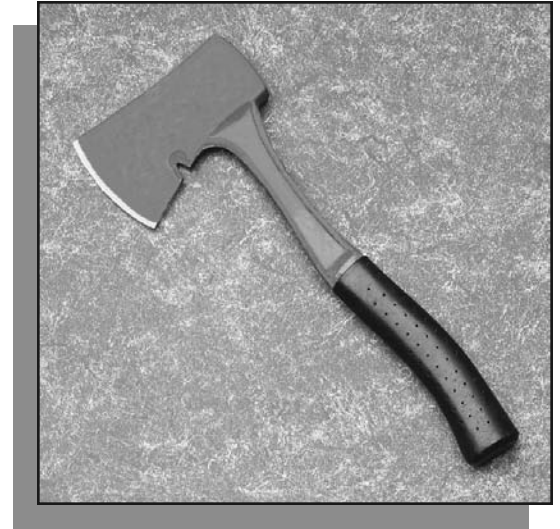

### Student Challenge

- 1
  - a. Use a stack of paper plates or cardboard circles as a model of a tree. Then, use your K'NEX Axe to chop the tree. Describe what happens as the blade's tip hits the tree.
  - b. Next, try chopping the tree using the back side of the Axe's blade – the wide part of the wedge. Try to swing the Axe with the same amount of force as you used in Step 1a. What happens? Explain how the wedge shape of an axe's blade helps make chopping wood easier.
- 2
  - a. What other tools can you think of that use a sharp wedge for cutting? Work with a partner to list as many examples as you can.
  - b. Can you think of other examples of objects that are as sharp as an axe which have a thin wedge that broadens into a wide wedge?
- 3
 

Some of the first tools that early humans used were different types of wedges made from stones. Find out more about these tools: when and how they were made and how they were used. Make a poster with drawings and labels to show what you learned.

Build a few of these tools out of K'NEX. Demonstrate how they are used.

# The Hand Drill Lesson Plan

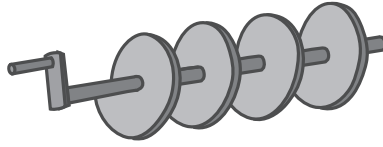

**Lesson Length:** 30-45 minutes

## Objectives



- Understand what a screw is and how it does work
- Demonstrate how a drill functions as a screw and an inclined plane
- Distinguish between different types of screws
- Identify how a drill does work
- Explain what pitch is and how it relates to a screw and drill
- Determine how the pitch of the drill bit affects work being done
- Compare and contrast drill bits and differentiate between them

## Materials

- can or tube about 120 centimeters in diameter (such as a small coffee can)
- 3 to 5 ping pong or K'NEX Balls
- ruler
- variety of screws
- extra K'NEX pieces

## Every screw has a job to do

If possible, students should be given the opportunity to compare a real hand drill to the K'NEX Drill. Drills can use different sized drill bits to make holes of different sizes. The tip of the drill bit has the cutting edges which start the hole. The spiraling ridges (the inclined plane) along the length of the bit increase the size and depth of the hole, creating wood shavings.

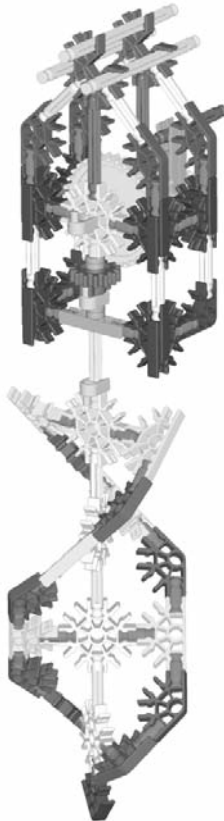

## Journal Check

- ✓ Description comparing a drill bit to an inclined plane
- ✓ Comparison of balls being drilled out of a can with wood or metal shavings being drilled out of a hole
- ✓ Description regarding ease of use for drill bits with different pitches and how they fit different jobs

## QUESTIONS

- 1 A drill bit, like any screw, has several main parts. The rod in the center is called the body and the spiral ridges are called threads. Hold your K'NEX Hand Drill upright and move your fingers up one of the threads. Describe the path your fingers take. Explain how the drill bit is a special kind of inclined plane.
- 2 Put a few ping pong balls or K'NEX balls into an empty coffee can. Set the can on its side. Use your Hand Drill to drill into the open end of the can. What happens to the balls? Why? What does this explain about what happens to the wood, metal or other material when a real drill is used to make a hole? What other simple machine works the same way?
- 3 a. The distance between threads on a screw is called the pitch. A screw with a small pitch is easier to turn than a screw with a large pitch. To measure the pitch of your Drill bit, line up your ruler next to the body of the Drill bit and see how far one thread is from the next. Try making another drill bit with a different pitch. Then compare how they work; is one easier to use than the other? Why?  
b. Look at different kinds of screws to see how they differ in pitch. How do you think the different pitches help each drill bit do its job?

## ANSWERS

- 1 As the students walk their fingers up the threads of the Drill bit, they should see that even though the path moves in a spiral, it still moves upward on a slant, like any inclined plane. Suggest students take a piece of paper cut to form a right triangle and wrap it around a pencil. The sloped edge of the triangle forms an inclined plane, but when wrapped around the pencil, it spirals into a screw shape.

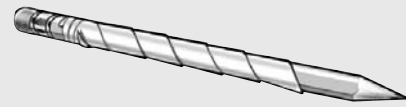

- 2 When drilling into the can, the ping pong or K'NEX Balls are pushed up and out of the can by the action of the Hand Drill just like the way a real drill bit
- 3 a. The pitch of the K'NEX Hand Drill bit is about 13 cm. The larger the pitch, the steeper the incline of a screw. A screw with a large pitch is harder to turn, because the material (such as wood shavings) moves up a steeper incline. Just like climbing a steep hill, this takes more effort. To make drill bits with different pitches, students will need to change the K'NEX pieces used for both the body and the threads. One possibility is to use white Connectors and green Rods for the body, and red Connectors and white Rods for the threads. The result is a drill bit with a smaller diameter and a smaller pitch than the original drill bit.  
b. Provide a variety of screws for students to look at, such as wood screws, machine screws, bolts, nuts, a corkscrew, a C-clamp and a jar lid. Some have small pitches, which make them easier to turn, while others have larger pitches, which make them cover more distance with each turn.

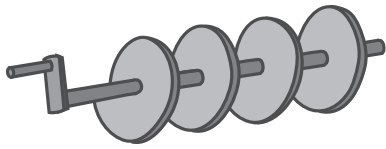

# The Hand Drill

## Every screw has a job to do

When you drill into a piece of wood, the sharp blades at the tip of the drill bit cut into the wood, making wood shavings. As you keep drilling, the shavings come spouting out of the hole around the edge of the drill bit. This happens because the drill bit is a screw – a spiral inclined plane. As the blades cut more shavings, the only place for the rest of the shavings to go is up. They get pushed right up the slope and out!



## Student Challenge

- 1 A drill bit, like any screw, has several main parts. The rod in the center is called the body and the spiral ridges are called threads. Hold your K'NEX Hand Drill upright and move your fingers up one of the threads. Describe the path your fingers take. Explain how the drill bit is a special kind of inclined plane.
- 2 Put a few ping pong balls or K'NEX balls into an empty coffee can. Set the can on its side. Use your Hand Drill to drill into the open end of the can. What happens to the balls? Why? What does this explain about what happens to the wood, metal or other material when a real drill is used to make a hole? What other simple machine works the same way?
- 3
  - a. The distance between threads on a screw is called the pitch. A screw with a small pitch is easier to turn than a screw with a large pitch. To measure the pitch of your Drill bit, line up your ruler next to the body of the Drill bit and see how far one thread is from the next. Try making another drill bit with a different pitch. Then compare how they work; is one easier to use than the other? Why?
  - b. Look at different kinds of screws to see how they differ in pitch. How do you think the different pitches help each drill bit do its job?

# The Archimedes Screw Lesson Plan

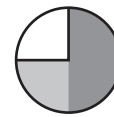
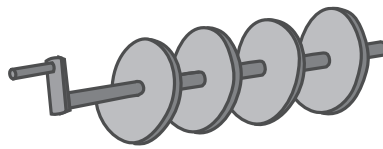

**Lesson Length:** 30-45 minutes

## Objectives



- Understand what a screw is, how it does work and what advantages it offers
- Demonstrate how an Archimedes screw functions as a screw
- Understand how an Archimedes screw does work
- Distinguish between different types of screws
- Determine how an Archimedes screw is a type of inclined plane
- Demonstrate how the pitch of a screw affects work being done
- Understand the history associated with the Archimedes screw
- Practice creative design and problem-solving

## Materials

- small weights to place inside K'NEX Balls
- K'NEX Rubber Band Scale
- extra K'NEX pieces

## Every screw has a job to do

The Archimedes screw was invented long ago, but it is still used today, typically for irrigation. Some indoor playgrounds that have a pit full of balls for children to jump into also use a similar device to lift balls out of the pit for washing. This type of screw is helpful and fun to watch! Other uses for an Archimedes-type screw are to transfer grain and remove rubble from a digging site.

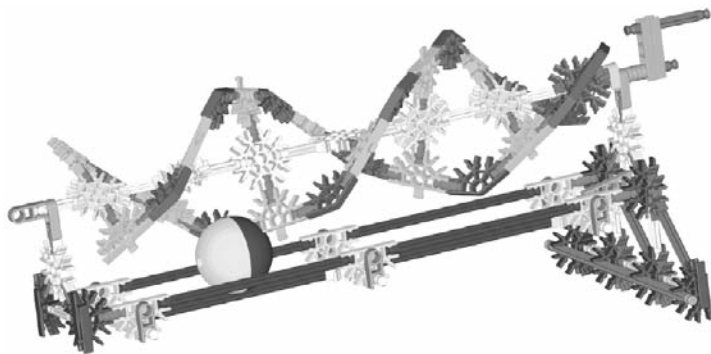

## Journal Check

- ✓ Predictions and observations of the Ball's motion along the Archimedes Screw
- ✓ Description of how additional weight affects the Ball's movement
- ✓ Rubber Band Scale measurements and explanation of force required to move the weighted Ball up the incline
- ✓ Illustration and description of how to alter this model so it can accommodate moving water

## QUESTIONS

- 1 a. Place a K'NEX Ball at the base of the Archimedes Screw. Predict what will happen to the Ball when the Screw turns. Turn the crank. Write down your observations.
  - b. Open your K'NEX Ball and add weight inside. Snap the Ball back together.  
*(Hint: A wedge would help split the Ball into its original halves. Try separating the two halves K'NEX style. Place a yellow or red Rod through the center of the Ball. Hold the ends of the Rod and quickly roll the Ball back and forth on a hard surface. When the halves separate, pull them apart.)*
  - c. Move the Ball along the Archimedes Screw again. How does the added weight affect the effort used to move the Ball up the Screw? Is it harder or easier to move this Ball? Write a description of your experience.
  - d. How much force is needed to move the Ball up the Archimedes Screw? Conduct each experiment again using the K'NEX Rubber Band Scale to measure the force. Record your results and explain what you found.
- 2 Imagine you want to use the Archimedes screw to move water as it was originally intended. How would you change your model to make it work? Write a description and draw a picture to show your plan. For a real challenge, experiment with materials to actually do this with your K'NEX model.
- 3 Pretend you have a ball factory and you want to use an Archimedes screw to take the balls off the assembly line and put them in boxes. Add new parts to your Archimedes Screw so that balls can feed into the bottom and then be dropped off the top into a box. Write a paragraph explaining how your Archimedes Screw functions and your reasons for designing it this way.

## ANSWERS

- 1 a. Students should write the predictions for what the Ball will do before they turn the crank. Most will probably guess that the Ball will move up the slope. Some might expect the Ball to rotate around the shaft of the screw. They will see that the Ball moves straight up the track to the top of the machine.
 

The Archimedes Screw's crank should be turned clockwise (looking up the screw from its lower end).

  - c. The added weight inside the Ball will make it harder to move the Ball up the incline. However, if the weight is not significant enough, it may not be perceptible to the students from turning the crank.
  - d. The Rubber Band Scale will be able to measure subtle differences in the force needed to transport the Balls (with different weights inside) up the incline. This will prove and reinforce the advantage provided and the impact of the weights on the effort required.
- 2 To make an Archimedes screw that would hold water, the screw must rest in a trough or be enclosed in a tube. The threads of the screw must be solid blades with a watertight seal to the sides of the trough or tube, so that water cannot leak through or under the threads as the screw turns.
- 3 Students might build a tray at the bottom of the screw to feed balls in, and they can adapt the top of the screw to leave an opening for the balls to drop out. Encourage them to tinker with their models to see what will work best. Emphasize that there is no one right answer; students may come up with different workable designs. They might also add other devices to move the balls, such as ramps or levers.

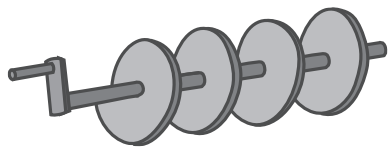

# The Archimedes Screw

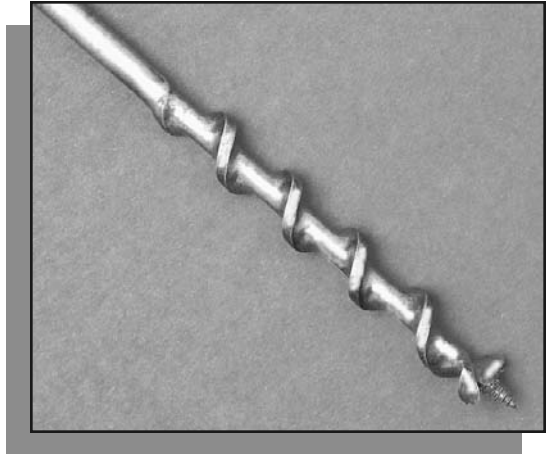

## Every screw has a job to do

More than two thousand years ago, people used a simple machine to lift and transport water out of streams to water their crops, drink, bathe and even empty water out of ships. This machine, called the Archimedes screw, was invented by the Greek scientist and mathematician, Archimedes. It consists of a screw inside a tube, with an opening at each end. Water is extremely heavy so it is nearly impossible to lift and move a lot of it at one time. By turning a handle on an Archimedes screw, the water moves easily up the tube, riding along the slope of the screw— to travel long and short distances.

### Student Challenge

- 1
  - a. Place a K'NEX Ball at the base of the Archimedes Screw. Predict what will happen to the Ball when the Screw turns. Turn the crank. Write down your observations.
  - b. Open your K'NEX Ball and add weight inside. Snap the Ball back together. *(Hint: A wedge would help split the Ball into its original halves. Try separating the two halves K'NEX style. Place a yellow or red Rod through the center of the Ball. Hold the ends of the Rod and quickly roll the Ball back and forth on a hard surface. When the halves separate, pull them apart.)*
  - c. Move the Ball along the Archimedes Screw again. How does the added weight affect the effort used to move the Ball up the Screw? Is it harder or easier to move this Ball? Write a description of your experience.
  - d. How much force is needed to move the Ball up the Archimedes Screw? Conduct
- 2
 

each experiment again using the K'NEX Rubber Band Scale to measure the force. Record your results and explain what you found.

Imagine you want to use the Archimedes screw to move water as it was originally intended. How would you change your model to make it work? Write a description and draw a picture to show your plan. For a real challenge, experiment with materials to actually do this with your K'NEX model.
- 3
 

Pretend you have a ball factory and you want to use an Archimedes screw to take the balls off the assembly line and put them in boxes. Add new parts to your Archimedes Screw so that balls can feed into the bottom and then be dropped off the top into a box. Write a paragraph explaining how your Archimedes Screw functions and your reasons for designing it this way.

# The Propeller Lesson Plan

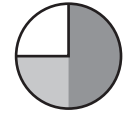
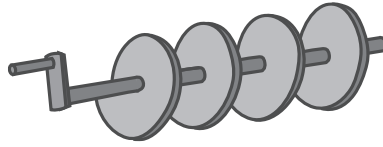

**Lesson Length:** 30-45 minutes

## Objectives



- Understand what a screw is and how it does work
- Demonstrate how a propeller functions as a screw
- Understand how a propeller works
- Compare and contrast propeller with other screws
- Experiment with the work a propeller does
- Compare propellers for ships and planes
- Determine the early history of the airscrew

## Materials

- extra K'NEX pieces
- fan or blow dryer (optional)

## Every screw has a job to do

The propeller, like any other screw (even the Archimedes screw), has a body and threads. And, just like other screws, something travels up the propeller as well. Wood moves up the slope of the drill, water moves up the slope of the Archimedes screw, and air molecules move up the inclined plane of the propeller!

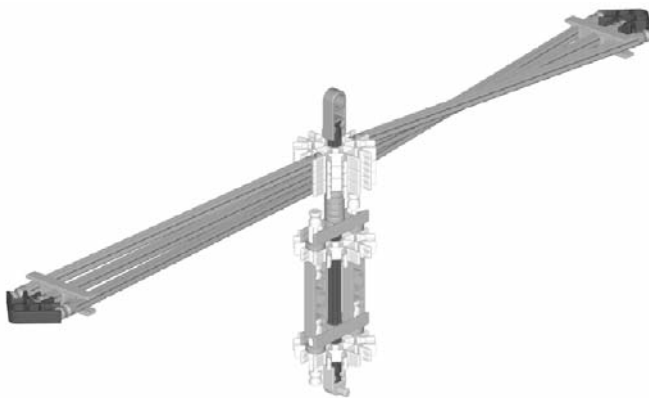

## Journal Check

- ✓ Description and labeled drawing of how a propeller is different from other screws
- ✓ Description of Propeller wind test experiments and results
- ✓ Altered propeller design to include additional, larger blades and explanation
- ✓ Comparison between propellers for ships and planes
- ✓ Explanation of early history of the airscrew

## QUESTIONS

**1** a. How is the shape of this screw, the Propeller, different from the shapes of other screws? Remember, a screw is an inclined plane that spirals around a central rod – the screw’s body. Draw and label the body of this screw and its inclined plane.

b. Your K’NEX Propeller will work in the wind. Test it and conduct experiments with a fan, studying the direction of the Propeller and the air. Describe your experiments and results.

**WARNING: Important note:** *Be extremely careful whenever using electrical devices. Teachers should monitor student activities at all times, and should examine devices before use.*

c. Add a few more white Connectors to the body (shaft) of your Propeller. Snap two gray Rods on each white Connector, just as you did to make the blades. Attach these new pieces to the blades to make them wider, making sure to keep the blades tilted to create an inclined plane. What would the Propeller look like if you kept making the blades wider and wider?

**2** Some propellers for airplanes or boats have more than two blades. Change your Propeller to make a four-blade model. Change the length of the blades if you wish. Describe your new model. Why do you think ship and plane propellers are different?

**3** When propellers were first developed, they were called airscrews. Use reference materials to find out about the invention of the airscrew. Try to build one of the early ones using K’NEX. Share your model and what you learned with the class.

## ANSWERS

**1** a. The Propeller has a shorter body and longer threads than a typical screw. The axis or shaft is the body, and the slope of each blade is a spiraling inclined plane.

b. As students make the blades wider by adding more K’NEX pieces, the Propeller’s spiraling inclined plane should become more obvious. The Propeller will look more like a typical screw, with a spiral that wraps around the body (a kind of spiral staircase).

c. Students might try making a four-blade Propeller using yellow Rods. The result will look more like a ship’s propeller or the blades of a window fan.

**2** The propeller for an airplane and a ship differ because they move through different materials. Water is much denser than air, so the ship’s propeller must be heavier and more sturdy. The airplane’s propeller must be lightweight to fly.

**3** Some early derivatives of the airscrew came from a Swedish-American engineer and inventor named John Ericsson. He introduced the screw propeller, which could be used instead of paddlewheels on ships. In 1837, Ericsson built the first commercial ship that was driven by air propellers. An earlier propeller, developed by John Fitch in 1796, consisted of a rod with a spiral around it.

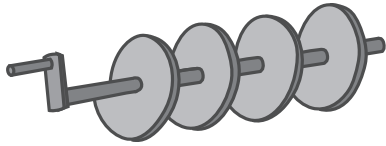

# The Propeller

## Every screw has a job to do

Another name for a propeller is an airscrew – a screw that turns and cuts through the air. The long blades of the propeller are the screw’s threads, and the propeller’s shaft is the screw’s body. A propeller turns very fast. Its blades cut through the air and push the air backward, which causes the plane to move forward.



## Student Challenge

- 1
    - a. How is the shape of this screw, the Propeller, different from the shapes of other screws? Remember, a screw is an inclined plane that spirals around a central rod – the screw’s body. Draw and label the body of this screw and its inclined plane.
    - b. Your K’NEX Propeller will work in the wind. Test it and conduct experiments with a fan, studying the direction of the Propeller and the air. Describe your experiments and results.
- WARNING: Important note:** Be extremely careful whenever using electrical devices. Teachers should monitor student activities at all times, and should examine devices before use.
- c. Add a few more white Connectors to the body (shaft) of your Propeller. Snap two gray Rods on each white Connector, just as you did to make the blades. Attach these new pieces to the blades to make them wider, making sure to keep the blades tilted to create an inclined plane. What would the Propeller look like if you kept making the blades wider and wider?
- 2 Some propellers for airplanes or boats have more than two blades. Change your Propeller to make a four-blade model. Change the length of the blades if you wish. Describe your new model. Why do you think ship and plane propellers are different?i
  - 3 When propellers were first developed, they were called airscrews. Use reference materials to find out about the invention of the airscrew. Try to build one of the early ones using K’NEX. Share your model and what you learned with the class.

# The Playground Station Lesson Plan

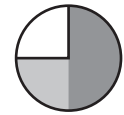
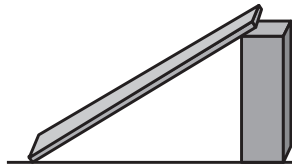

**Lesson Length:** 30-45 minutes

## Objectives

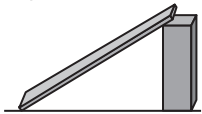

- Identify different types of inclined planes
- Demonstrate how spiral slides and ladders function as screws and inclined planes
- Understand how different inclined planes (including screws and wedges) do work
- measure the pitch of a screw
- Perform math calculations to find Mechanical Advantage
- Identify relationships between effort and distance
- Understand the similarities between all the different types of inclined planes
- Determine how inclined planes do work in everyday life

## Materials

- ruler
- tape measure or string
- extra K'NEX pieces

## Every simple machine has a job to do

A playground is a great place to point out and experience all sorts of inclined planes, screws and wedges! Take a trip outside for a fun review of simple machines. Point out the ramps, steps, ladders, roofs and other inclined planes along the way.

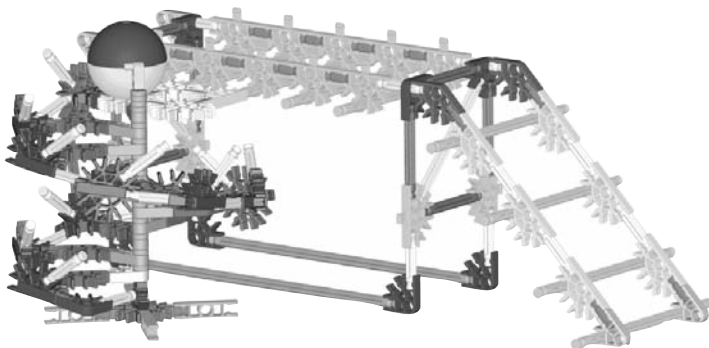

## Journal Check

- ✓ Identification and explanation of two simple machines in the Playground Station
- ✓ Playground Station measurements
- ✓ Math equation and solution to determine Mechanical Advantage
- ✓ Description of a roofline inclined plane and how it helps keep snow off the roof
- ✓ Description of other simple machines added to the Playground Station and how these do work

## QUESTIONS

- 1 Look over your Playground Station model and identify two simple machines: an inclined plane and a screw. Use the words “effort” and “distance” to explain how these two simple machines help you. Write your explanation.
- 2 Measure the distance from the ground to the top of the Playground Station, where the yellow Rods form monkey bars. Then, measure the length of the sloping ladder and the length of the slide as it spirals around. Use your measurements to figure out the Mechanical Advantage for the slide and the ladder. (See the “What’s the Mechanical Advantage?” Reference Sheet.)
- 3
  - a. Add a pointed roof to keep the rain and snow off your Playground Station. What kind of simple machine is a roof? What kind of job does it do and how does it do this job?
  - b. Add other inclined planes, screws or wedges to your Playground Station. To get ideas, think of other examples of these simple machines and how they work.

## ANSWERS

Use the Playground Station as a culminating activity for the study of inclined planes, screws and wedges.

- 1 The spiral slide is a screw and the angled ladder is an inclined plane. Both of these simple machines help by letting you travel a longer distance than the direct distance between the top and bottom of the Playground Station. They make the ride down fun and safe by slowing the speed and the impact and lengthening the trip.

Because the spiral slide slopes, it doesn’t take much effort to move downward. Suggest that students think of the slide as a ramp to climb up; this shows how the slide makes work easier. Climbing up this slide is easier than climbing straight up.

The ladder makes it easier for you to climb to the top of the Playground Station. You need to use less effort, but you have a greater distance to travel than if you climbed an upright ladder.

- 2 The Playground Station is about 14 cm tall. The angled ladder is about 19 cm long, and the spiral slide is about 70 cm long (measured around the outside edge of the slide with a tape measure or string). Divide the length of either slope by the upright distance to find the Mechanical Advantage.

The Mechanical Advantage for the ladder is  $19 \div 14 = 1.36$ . You have to travel 1.36 times farther, but climbing is 1.36 times easier.

With the spiral slide, the Mechanical Advantage is  $70 \div 14 = 5$ . A ride down the slide is 5 times longer than if you went straight down.

- 3
  - a. Allow students to build any size or shape roof they wish, as long as it slopes. A sloping roof is an inclined plane. The slope makes it easier for rain and snow to slide off, preventing the roof from collecting too much rain or snow and leaking.
  - b. Students might change their Playground Stations by adding a straight slide, stairs, or ramp (inclined planes), a propeller, fan, or Archimedes screw (screws) or a sand shovel (wedge).

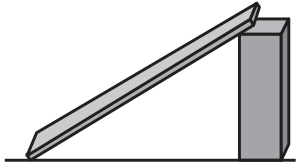

# The Playground Station

## Every inclined plane has a job to do

On a playground, you don't really need to make work easier, but simple machines can make having fun even more fun!

Whether you're racing up the ladder or whooshing down the slide, you're using a simple machine that changes the amount of effort you use *and* the distance you cover. Simple machines are everywhere.



### Student Challenge

- 1 Look over your Playground Station model and identify two simple machines: an inclined plane and a screw. Use the words "effort" and "distance" to explain how these two simple machines help you. Write your explanation.
- 2 Measure the distance from the ground to the top of the Playground Station, where the yellow Rods form monkey bars. Then, measure the length of the sloping ladder and the length of the slide as it spirals around. Use your measurements to figure out the Mechanical Advantage for the slide and the ladder. (See the "What's the Mechanical Advantage?" Reference Sheet.)
- 3
  - a. Add a pointed roof to keep the rain and snow off your Playground Station. What kind of simple machine is a roof? What kind of job does it do and how does it do this job?
  - b. Add other inclined planes, screws or wedges to your Playground Station. To get ideas, think of other examples of these simple machines and how they work.

# INCLINED PLANES

## Part & Model

### List

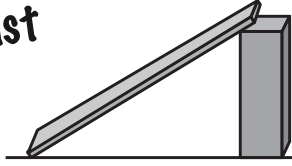

		ROLLER COASTER RAMP	MOVING TRUCK	SPLITTING WEDGE	CHISEL	AXE	HAND DRILL	ARCHIMEDES SCREW	PROPELLER	PLAYGROUND STATION	TOTAL PARTS IN INCLINED SET
	Tan Connector	5	4	0	0	0	5	1	1	1	19
	Gray Connector	6	8	0	0	0	0	9	1	10	12
	Orange Connector	4	12	5	0	4	3	3	6	4	17
	Lt Gray Connector	8	0	0	3	3	0	0	0	5	8
	Red Connector	6	12	0	0	0	3	0	2	9	12
	Green Connector	4	8	6	0	6	12	14	0	12	14
	Yellow Connector	5	8	6	0	0	7	8	0	8	8
	Blue Connector	0	0	0	0	0	2	6	0	5	6
	White Connector	3	6	0	2	3	5	9	5	3	9
	Purple Connector	8	10	0	0	0	12	12	0	19	19
	Gold Connector	22	6	0	0	0	0	12	0	14	22
	Yel/Grn Female Hinge	0	2	5	0	0	0	0	0	0	5
	Lt. Blue Male Hinge	0	2	5	0	0	0	0	0	0	5
	Green Rod	15	43	0	0	3	35	49	0	45	49
	White Rod	42	28	0	1	0	11	20	4	34	42
	Blue Rod	6	12	2	0	0	3	5	0	9	13
	Yellow Rod	0	4	10	0	10	5	0	0	2	10
	Red Rod	11	4	5	0	0	0	6	1	1	11
	Gray Rod	0	0	0	2	4	0	1	6	2	9
	Gold Rod	13	0	0	2	0	0	0	0	9	13
	Sm. Tire	1	0	0	0	0	0	0	0	0	1
	Med. Tire	1	4	0	0	0	0	0	0	0	4
	Sm. Pulley	1	0	0	0	0	0	0	0	0	1
	Lge. Pulley	7	4	0	0	0	0	0	0	0	7
	Sm. Blue Gear (14)	0	0	0	0	0	0	0	0	0	1
	Sm. Gray Gear (14)	0	2	0	0	0	1	0	0	0	2
	Red Ball Half	0	0	0	0	0	0	1	0	1	1
	Yellow Ball Half	0	0	0	0	0	0	1	0	1	1
	Med. Yellow Gear (34)	0	0	0	0	0	1	0	0	0	1
	Lt. Blue Spacer	8	0	0	0	0	5	0	10	14	24
	Rubber Band #18	0	0	0	0	0	0	0	0	0	3
	Cord	1	0	0	0	0	0	0	0	0	1
	Tracking (BBF)	1	0	0	0	0	0	0	0	0	1
	<b>TOTALS PER MODEL</b>	<b>178</b>	<b>179</b>	<b>44</b>	<b>10</b>	<b>33</b>	<b>110</b>	<b>157</b>	<b>36</b>	<b>208</b>	<b>352</b>