

FORCE AND NEWTON'S LAWS TEACHER'S GUIDE

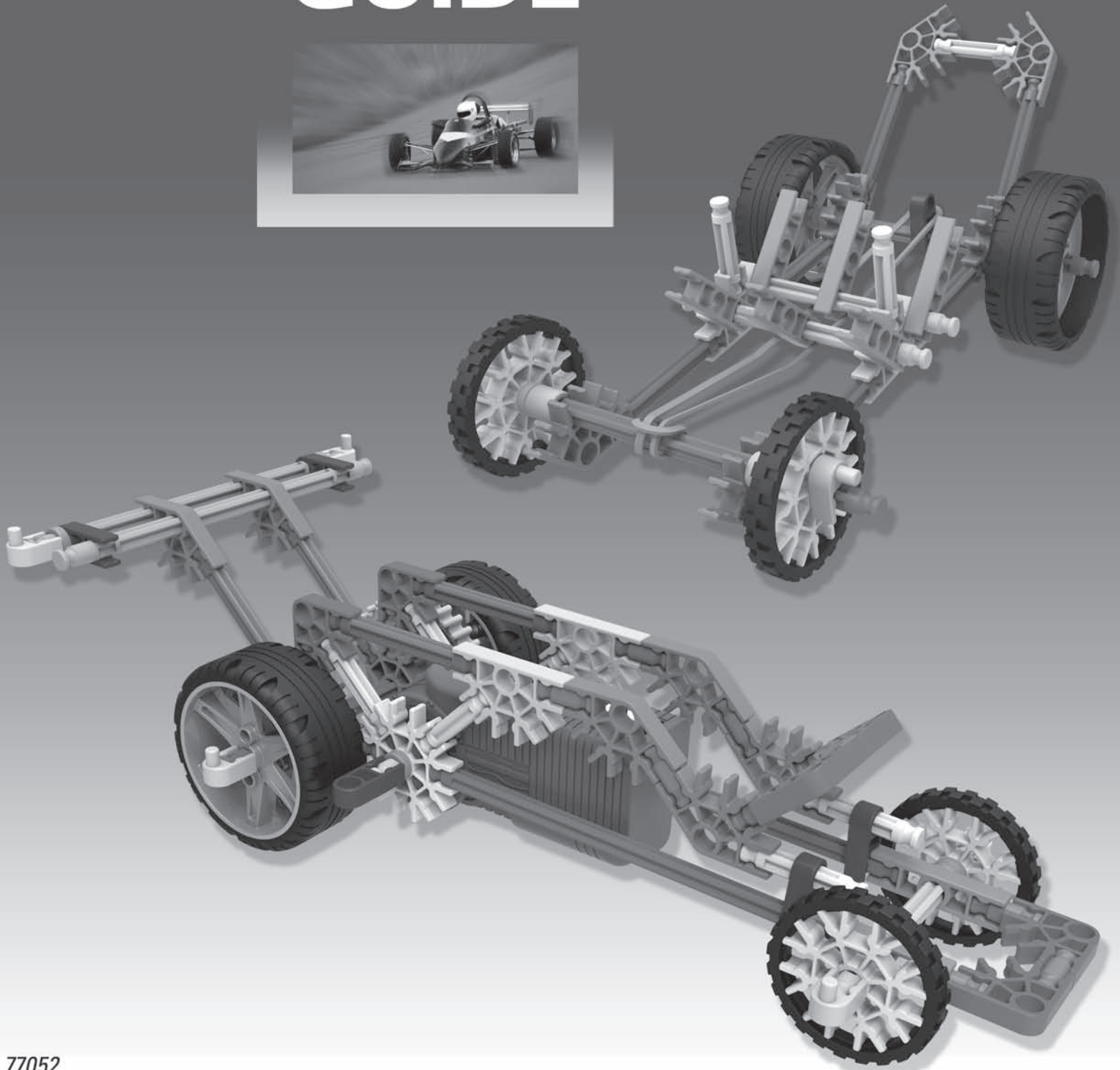

FORCE AND NEWTON'S LAWS TEACHER'S GUIDE

V1-10/13

©2013 K'NEX Limited Partnership Group
and its licensors.

K'NEX Limited Partnership Group
P.O. Box 700
Hatfield, PA 19440-0700

K'NEX is a registered trademark of
K'NEX Limited Partnership Group.
Protected by International Copyright.
All rights reserved.

www.knexeducation.com
abcknex@knex.com
1-888-ABC-KNEX

Author:

Bill Metz Ed.D.

- Presidential Award for Excellence in Science Teaching
- Governor's Institute for Physical Science Educators
- Carnegie Mellon University: Staff Consultant for Full Option Science System (FOSS)

A NOTE ABOUT SAFETY:

Safety is of primary concern in science and technology classrooms. It is recommended that you develop a set of rules that governs the safe, proper use of K'NEX in your classroom. Safety, as it relates to the use of the Rubber Bands should be specifically addressed.

⚠ CAUTIONS:

Students should not overstretch or overwind their Rubber Bands. Overstretching and overwinding can cause the Rubber Band to snap and cause personal injury. Any wear and tear or deterioration of Rubber Bands should be reported immediately to the teacher. Teachers and students should inspect Rubber Bands for deterioration before each experiment.

Caution students to keep hands and hair away from all moving parts. Never put fingers in moving Gears or other moving parts.

⚠ WARNING:

CHOKING HAZARD - Small parts.
Not for children under 3 years.

⚠ AVERTISSEMENT:

DANGER D'ÉTOUFFEMENT - Pièces de petite taille.
Ne pas donner aux enfants de moins de 3 ans.

Table of Contents

<i>INTRODUCTION</i>	3-10
<i>STANDARDS ALIGNMENTS</i>	11-20
LESSONS	
Lesson 1: Dilemma in Detroit - Designing Vehicles	21-37
<i>Model: Free build</i>	
Lesson Plan	21-26
Design Loop	27
Gravity Design Brief	28
Student Response Sheets 1-5	29-36
Egg-citing Design Brief	37
Lesson 2: Rolling, Rolling, Rolling	38-43
<i>Model: Rolling Racer</i>	
Lesson Plan	38-40
Student Response Sheet 6	41-43
Lesson 3: Rubber Band Racers	44-63
<i>Models: Rubber Band Racers</i>	
Lesson Plan Part 1 – Comparing Racers	44-47
Student Response Sheets 7-8	48-51
On the Surface Design Brief	52
Sample “Fair Test” Investigation	53
Lesson Plan Part 2 – Investigating Weight.	54-55
Student Response Sheet 9	56-58
Lesson Plan Part 3 – Adding Energy.	59-60
Student Response Sheet 10	61-63
Lesson 4: Spring Racers	64-75
<i>Models: Spring Racers</i>	
Lesson Plan Part 1 – Energy Sources.	64-66
Student Response Sheets 11-12	67-70
Tractor Pull Design Brief	71
Lesson Plan Part 2 – Collecting Data	72-73
Advertising Design Brief	74-75
Lesson 5: Racing With The Wind	76-82
<i>Model: Wind Racer</i>	
Lesson Plan	76-78
Student Response Sheet 13	79-81
Wind Bag Express Design Brief	82
Lesson 6: Motorized Racers	83-91
<i>Models: Battery Powered Racers</i>	
Lesson Plan	83-85
Student Response Sheets 14-15	86-91
Lesson 7: Flywheel Racer	92-96
<i>Model: Pull String Flywheel Racer</i>	
Lesson Plan	92-94
Student Response Sheet 16	95-96

Introduction

*This K'NEX Education construction set, and its accompanying **Teacher's Guide**, has been designed for students to investigate a variety of concepts related to forces, energy, and motion. These concepts are fashioned around rigorous content and national standards in science education (NSES).*

INSTRUCTIONAL STRATEGY

The majority of lessons provided in this guide follow the 5E instructional model. This teaching strategy begins with an **ENGAGEMENT** wherein the teacher creates interest and elicits responses from the students through interactive demonstrations and discussions. In the second phase, the **EXPLORATION**, students are encouraged to work together in building the K'NEX Education models and crafting responses to initial questions. Students then **EXPLAIN** the concepts and definitions in their own words. They are subsequently expected to apply the concepts and skills during the **ELABORATION** segment while using formal labels, definitions and reflective explanations. Students may also be challenged to modify the model to perform a different or enhanced function. In the final phase of the 5E model, the **EVALUATION**, students are expected to further apply the new concepts as they address real life applications and **Design Brief Challenges**.

There are a number of extension opportunities in each investigation that allow students to 'go beyond' the rudiments of the basic lesson. Teachers should be aware that the Design Brief Challenges can be approached in a number of ways and students should be given the time and the encouragement to pursue these divergent, open-ended invitations to inquiry.

PROCESS SKILLS

As students engage in the activities outlined in this guide, they will be learning, practicing, and applying integrated process skills. Students will be expected to craft fair test procedures, create meaningful data displays, make reasonable and data supported reports, and analyze their collected data in light of the problem at hand. These are just some of the process skills that students must employ as they use the K'NEX Education Forces and Newton's Laws Set.

TERMS

Throughout the K'NEX Education Teacher's Guide, the term "**fair test**" has been used. Children have an innate sense of fairness and tend to understand this terminology better than the traditional "controlled experiment."

The identification and control of variables is a necessary process in any authentic investigation. There may also be some confusion about the terms used to identify the processes of an experiment. Creating and displaying terms and definitions is suggested as a reference for students. It may be helpful to also include synonyms for these terms as part of the definition since this may provide additional clarity for students.

For the purposes of this manual, a **variable** is considered any measurable characteristic or attribute. Any variable that is deliberately changed is referred to as the **independent variable**, (sometimes called the controlled, manipulated, or changed variable) while the variable that will be measured is referred to as the **dependent variable**, (also called the responding, or measured variable). Lastly, any independent variable that is kept the same is referred to as a **constant**.

SCIENCE NOTEBOOKS

As students tackle the challenges presented to them, they will record and interpret their observations, thoughts, data, and illustrations. It is also expected that they will reprocess this information as they draw conclusions and craft additional queries for further investigations.

For the students, maintaining a science notebook provides a continuous record of events that can also be used as supportive evidence, self-assessment, and research. Additionally, notebooks and journals offer a logical place for the students to organize information in ways that make sense to them.

Science notebooks and journals also provide teachers with feedback on the ways in which students are processing and interpreting information. These documents are formative assessment treasure troves that allow for the discovery of students' misconceptions and misdirection.

STUDENT RESPONSE SHEETS

The Student Response Sheets provide space for recording observations, and ask questions to provoke student thinking about both the vehicle being investigated (Explain) and the concepts involved (Elaborate). Teachers should reproduce both the Student Response Sheets and the Design Briefs (see below) for their students. They are identified by a photocopying icon. 

These pages, together with the students' notes made in response to the design challenges, can either be compiled in a folder to serve as the science journal for this particular topic, or they can be added to an existing science journal that will cover the work completed during the entire academic year.

DESIGN BRIEFS

The design brief is an instructional strategy intended to raise the cognitive level of existing lessons. These unique investigations challenge students to go beyond the scripted nature of guided-discovery activities and apply content/concepts to novel situations.

Each design brief begins with **The Context**, a rationale for the activity, followed by **The Scenario**, which describes a plausible situation. The next segment is a description of **The Challenge**, while the last two sections address **The Limitations** and **The Rules** by providing guidelines for project completion and project evaluation.

Introduction

GRAPHING

Throughout the investigations there are multiple opportunities for students to display and communicate their experimental data in the form of tables and graphs. It is not assumed that all students will be conversant with constructing and implementing these necessary data displays. Toward that end, the initial experiences in this manual provide the formats, the labels, and the specific directions for filling in the tables and graphs. As you and your students progress through the manual you will find that the crafting of these communication tools is increasingly the responsibility of the students. As noted above, it is strongly suggested that students maintain a science notebook or journal so as to have a continuous record for reflection and reference.

Graphing Conventions

Teaching students a consistent way of crafting data displays is essential for the accurate and uniform processing and interpretation of data. While students could use the Internet or computer programs such as Microsoft® Excel® to generate graphs, it is suggested that they also learn how to create graphs without this technology since the hardware may not be readily available, or for that matter, not necessary.

The two basic graphs that are most widely used are the line graph and the bar graph. Generally, if the data is discrete or categorical, such as the days of the week, species of tree, brand of cereal, ethnic group, and so on, the bar graph should be used. On the other hand, if the data is continuous and the measurements involve a standard scale then the most appropriate graph is the line graph. The following offers a set of graphing conventions that students may find helpful as they develop their competence with the graphing process.

Example: The students conducted an investigation to determine if the height of a ramp affected the distance the racer rolled after leaving the bottom end of a ramp. The ramp height was changed in 10-centimeter increments to a maximum height of 60 centimeters and data was collected at the six different ramp heights. A student data sheet might look like the one the next page.

Sample Data Chart:

RAMP HEIGHT AND RACER DISTANCE

Height of Ramp (in centimeters)	Racer Distance (in centimeters)			
	Trial #1	Trial #2	Trial #3	Average
10 cm	80	75	82	79
20 cm	110	105	120	112
30 cm	150	150	149	150
40 cm	200	210	220	210
50 cm	290	280	295	288
60 cm	320	300	312	311

Graphing Guidelines

- Every graph should have a heading that identifies the person, or persons, responsible for the display. The date and other identifying information should also be included.
- Every graph should have a title that briefly describes the investigation. In the sample investigation the title could be: **“Ramp Height and Racer Distance.”**
- The horizontal axis should first be labeled with the letter **X** and the vertical axis with a **Y**.
- Data for the **independent variable**, the variable that is controlled or changed always goes on the **X-axis**. In our example the ramp height is changed and therefore must be placed on the **X-axis**.
- The distance the racer traveled is the **dependent variable**, the variable that responded to the change made in the ramp height. Data for the dependent variable is placed on the **Y-axis**.
- Both axes should also be titled and these descriptions should be the same as the titles on the data table. **Ramp Height (in centimeters)** for the **X-axis** and **Racer Distance (in centimeters)** for the **Y-axis** would be appropriate titles for the data chart, as well as the graph. Note that the units of measurement should appear in parentheses following each title.
- The axes should be numbered (scaled) so that the investigative data will fit on the graph paper.
- Numbering the axes is a matter of finding a reasonable interval to accommodate the collected data. The numbering process will be much easier for students if they use a common multiple (2, 5, 10, etc.).
 - * With the sample data above for the **X-axis**, (**Ramp Height**), students will begin with zero at the origin and develop a scale that will allow the highest data value (60 centimeters) to fall near the right side of the page. Students can divide the number of squares from the origin to the right side of the page into the highest data value for the ramp height. They then select the next highest number above that value that is easy to count by. For example, if there are 28 squares from the origin to the right side of the page and the highest ramp height is 60 centimeters, students would

Introduction

divide 28 into 60 and get a value of 2.1 centimeters per square. They may decide that the next highest number that is easy to count by is 3 and would then label the first line on the **X**-axis to the right of the origin with a 3, the next line with a 6, and so on. They can stop numbering when they reach 60.

* The **Y**-axis (**Racer Distance**) numbering follows a similar process. Students will begin with zero at the origin and develop a scale that will allow the highest data value (320 centimeters) to fall near the top of the page. Students will divide the number of squares from the origin to the top of the page into the highest data value for the racer distance. They then select the next highest number above that value that is easy to count by. For example, if there are 40 squares from the origin to the top of the page and the highest racer distance is 320 centimeters, they would divide 40 into 320 and get a value of 8 centimeters per square. Students may decide that the next highest number that is easy to count by is 10, so that they would then label the first line on the **Y**-axis above the origin with a 10, the next line with a 20, and so on. They can stop numbering when they reach 320.

- The graph should be made large enough to fill the available space. The graph's size can be changed by increasing, or decreasing, the numerical increment on the axes. For example, if an axis is numbered in increments of 10 and the graph is too small, then changing the increments to 5 will stretch the graph out to a larger size.

Line Graphs

- After the data is plotted on the graph, a line of "best fit" should be drawn. The data points are usually not connected in a dot-to-dot fashion. This "best fit" line (straight or smooth curve) should be drawn so that it passes through as many points as possible.

Name:

Class:

Date:

RAMP HEIGHT AND RACER DISTANCE

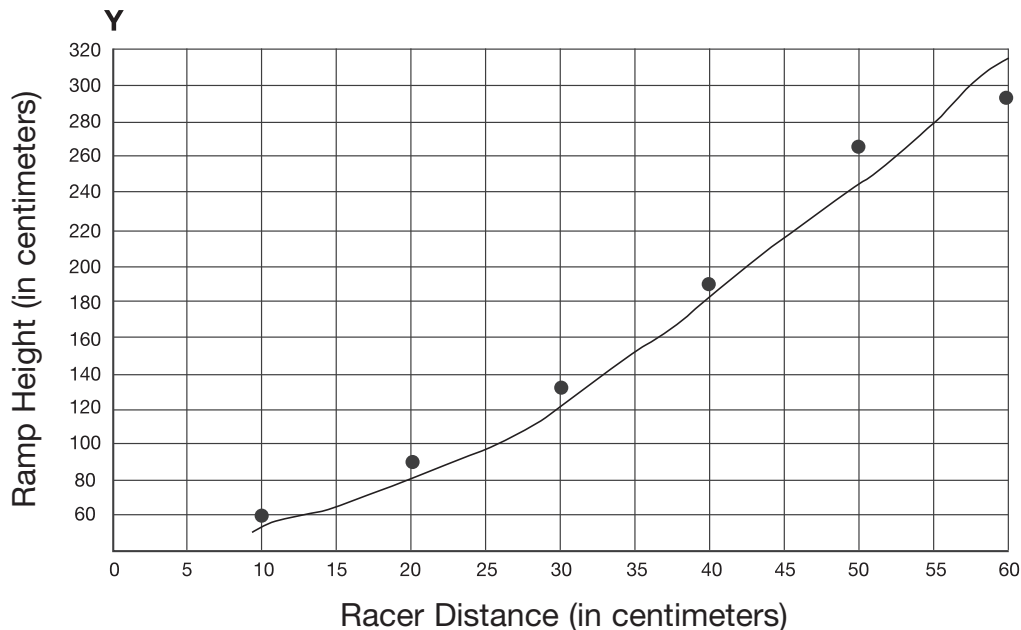

Bar Graphs

- The conventions for creating a bar graph are more or less the same as those for creating a line graph with the exception of the labeling along the X-axis. Since the independent variable is composed of discrete data, the intervals along the X-axis are evenly distributed. In addition, a space is generally inserted between each of the discrete labels on the X-axis. For example, if students were graphing their favorite vehicle, terms such as “Rolling Racer,” “Wind Racer,” “Rubber Band Racer,” etc. would be evenly spaced below the X-axis with appropriate spacing left between each entry. The bars for each type of vehicle would extend up from the X-axis directly above each of the labels.

MODEL BUILDING

These provide color-coded, step-by-step instructions for each of the models in this set. Most of the models in this set can be built in 15 minutes or less. It is suggested that you practice building the proposed model in advance. Experience with each model allows the teacher to trouble shoot those areas where students are most likely to encounter difficulties.

Resist the urge to help students through difficult building challenges. Students will work through these challenges and in the process, they will enhance their problem solving skills.

It is recommended that you have the students sort their materials before building. Each model has its parts count listed in the Building Instructions booklet.

SAFETY GUIDELINES

Establish safety guidelines. Take time to direct the students' attention to the safety warnings that are found in the Building Instructions booklets and set safety guidelines for use in the classroom/lab. Particular emphasis should be placed on the safe use of rubber bands.

Introduction

THE SCIENCE BEHIND THE K'NEX EDUCATION FORCE AND NEWTON'S LAWS SET

The information below outlines some of the basic science content that is presented in this Teacher's Guide. When used in combination with your local curriculum, textbook, and state standards you will be able to provide a comprehensive science experience for your students.

FORCE AND NEWTON'S LAWS

In each of the lessons included in this Teacher's Guide, an unbalanced force is ultimately applied to the wheels or axles of the various vehicles. This results in motion. In some instances the force is gravity, while in others the force is provided by the action of rubber bands, electric motors, fly wheels, wind, and spring motors.

ENERGY

Potential and kinetic energy are highlighted throughout the Teacher's Guide. When your students work with the gravity-powered vehicle of their own design, it is possible for them to compute the potential energy of the system using the formula:

$$\text{P.E.} = mgh$$

where

P.E. = Potential Energy	- Measured in Joules (J)
m = mass	- Measured in Kilograms (Kg)
g = acceleration due to gravity	- Measured in meters per second squared – (m/sec/sec)
h = height	- Measured in meters – (m)

Students can use this information to calculate the ideal speed/velocity of their vehicles at the bottom of their ramp system based on the following:

Potential Energy at the top of the ramp is converted to **kinetic energy** as the racer moves down the ramp. At the bottom of the ramp, the racer has no more potential energy as all of it has been converted to kinetic energy (motion). In actuality some of the potential energy has been used to rotate the wheels and some has been lost to friction. You can address friction with your students but the conceptual and mathematical explanation of energy lost to rotation is best left to the high school physics classroom. At the moment the vehicle reaches the bottom of the ramp,

$$\text{P.E. (Top of Ramp)} = \text{K.E. (Bottom of the Ramp)}$$

Since the formula for kinetic energy is **K.E. = $\frac{1}{2}mv^2$** , some substitution and mathematics will enable students to determine the speed/velocity of the vehicle at the bottom of the ramp.

If: $\text{P.E. (Top of Ramp)} = \text{K.E. (Bottom of Ramp)}$

And: $\text{P.E.} = mgh$
 $\text{K.E.} = \frac{1}{2}mv^2$

Then: $mgh = \frac{1}{2}mv^2$

Thus: $gh = \frac{1}{2}v^2$ (after dividing each side of the equation by m)
 $2gh = v^2$ (after dividing each side of the equation by $\frac{1}{2}$)
 $\sqrt{2gh} = v$ (after taking the square root of each side of the equation)

These mathematics calculations may be too difficult for your students but they are included here to assist you as you determine their abilities and needs in light of your curriculum goals and objectives.

In the case of the other vehicles, students will use indirect indications of the amount of potential energy they have added to the systems.

MOTION

The activities in the Teacher's Guide will use two techniques to describe the motion of the vehicles students investigate: the distance they travel and the average speed at which they travel those distances. The distance traveled will be measured in meters and will provide students with an indication that they have added potential energy to a system (vehicle) when the vehicle moves further and further.

To determine the average velocity of the vehicles they test, students will use the formula $v = d/t$. This is a classic rate and degree problem that students encounter regularly in their math classes. Lessons where the students compute the speed/velocity of their vehicles should provide excellent opportunities for you to integrate instruction with your math lessons.

TRANSFER OF ENERGY

The activities outlined in this guide enable students to observe and investigate the transfer of energy in a variety of mechanical systems. In most cases energy is transferred first to the axles and then to the wheels of the vehicles the students construct. In the case of the motorized racers, various gear systems are provided to alter the speed/velocity and mechanical advantage of the racers. The motorized racers will provide students with additional challenges as they trace the transfer of energy through the drive mechanism of the vehicles.

SIMPLE MACHINES

Two of the motorized racers use gear systems to transfer energy from the motor to the axle. These gear systems are examples of simple machines that either multiply the force applied to the axle or multiply the distance moved by the outside of the wheel as the axle turns. In the case of the geared down racer the mechanical advantage of the system is greater than one (>1) but the distance the wheels move in a given time is lessened. Thus the racer moves with more power, but at a slower speed. In the case of the geared up racer, the mechanical advantage of the system is less than one (<1) but the distance the wheels move in a given time is greater. Thus the racer moves with less power but at a faster speed. The activities included for the motorized racers will enable students to discover these concepts through experimentation.

NSES Content Standards Alignments

National Science Education Standards

Students will develop an understanding of:

UNIFYING CONCEPTS AND PROCESSES

- *Systems, order, and organization*
- *Evidence, models, and explanation*
- *Change, constancy, and measurement*
- *Form and function*

SCIENCE AS INQUIRY

- *Abilities necessary to do scientific inquiry*
- *Understanding about scientific inquiry*

PHYSICAL SCIENCE

- *Motions and Forces*
- *Transfer of Energy*

SCIENCE AND TECHNOLOGY

- *Abilities of technological design*
- *Understanding about science and technology*

SCIENCE IN PERSONAL AND SOCIAL PERSPECTIVES

- *Science and technology in society*

Reprinted with permission from 1996 National Science Education Standards by the National Academy of Sciences, Courtesy of the National Academies Press, Washington, D.C.





Standards for Technological Literacy: Content for the Study of Technology

Standards for Technological Literacy: Content for the Study of Technology (Grades 5-8) *Students will develop an understanding of:*

THE NATURE OF TECHNOLOGY
Core Concepts of Technology
• <i>Systems</i>
• <i>Processes</i>
• <i>Requirements</i>
• <i>Trade-offs</i>
DESIGN
The Attributes of Design
• <i>Design leads to useful products and systems</i>
• <i>There is no perfect design</i>
Engineering Design
• <i>Brainstorming</i>
• <i>Modeling, testing, evaluating, and modifying</i>
The Role of Troubleshooting, Research and Development, Invention and Innovation, and Experimentation in Problem Solving.
• <i>Troubleshooting</i>
• <i>Invention and innovation</i>
• <i>Experimentation</i>
ABILITIES OF A TECHNOLOGICAL WORLD
Apply Design Process
• <i>Apply design process</i>
• <i>Identify criteria and constraints</i>
• <i>Model a solution to a problem</i>
• <i>Test and evaluate</i>
• <i>Make a product or system</i>

Used with permission of the ITEEA (www.iteea.org)





NCTM Standards Alignments

National Council of Teachers of Mathematics Education Standards and Expectations for Grades 5 - 8

NUMBER AND OPERATIONS

Instructional programs from pre-kindergarten through grade 12 should enable all students to:

- *Understand numbers, ways of representing numbers, relationships among numbers, and number systems.*
- *Understand meanings of operations and how they relate to one another.*
- *Compute fluently and make reasonable estimates.*

Grades 3 - 5 Expectations: In grades 3 - 5 all students should:

Understand numbers, ways of representing numbers, relationships among numbers, and number systems.

- *Understand the place-value structure of the base-ten number system and be able to represent and compare whole numbers and decimals.*
- *Develop understanding of fractions as parts of unit wholes, as parts of a collection, as locations on number lines, and as divisions of whole numbers.*
- *Use models, benchmarks, and equivalent forms to judge the size of fractions.*
- *Recognize and generate equivalent forms of commonly used fractions, decimals, and percents.*

Grades 3 - 5 Expectations: In grades 3 - 5 all students should:

Understand meanings of operations and how they relate to one another.

- *Understand various meanings of multiplication and division.*
- *Understand the effects of multiplying and dividing whole numbers.*
- *Identify and use relationships between operations, such as division as the inverse of multiplication, to solve problems.*

Grades 3 - 5 Expectations: In grades 3 - 5 all students should:

Compute fluently and make reasonable estimates

- *Develop fluency with basic number combinations for multiplication and division and use these combinations to mentally compute related problems, such as 30×50 .*
- *Develop fluency in adding, subtracting, multiplying, and dividing whole numbers.*
- *Develop and use strategies to estimate computations involving fractions and decimals in situations relevant to students' experience.*
- *Select appropriate methods and tools for computing with whole numbers from among mental computation, estimation, calculators, and paper and pencil according to the context and nature of the computation and use the selected method or tools.*

ALGEBRA

Instructional programs from pre-kindergarten through grade 12 should enable all students to:

- *Understand patterns, relations, and functions.*
- *Represent and analyze mathematical situations and structures using algebraic symbols.*
- *Use mathematical models to represent and understand quantitative relationships.*
- *Analyze change in various contexts.*

Grades 3 - 5 Expectations: In grades 3 - 5 all students should:

Understand patterns, relations, and functions.

- *Represent and analyze patterns and functions, using words, tables, and graphs.*

Grades 3 - 5 Expectations: In grades 3 - 5 all students should:

Represent and analyze mathematical situations and structures using algebraic symbols.

- *Represent the idea of a variable as an unknown quantity using a letter or a symbol.*
- *Express mathematical relationships using equations.*

Grades 3 - 5 Expectations: In grades 3 - 5 all students should:

Use mathematical models to represent and understand quantitative relationships.

- *Model problem situations with objects and use representations such as graphs, tables, and equations to draw conclusions.*

Grades 3 - 5 Expectations: In grades 3 - 5 all students should:

Analyze change in various contexts.

- *Investigate how a change in one variable relates to a change in a second variable.*
- *Identify and describe situations with constant or varying rates of change and compare them.*

MEASUREMENT STANDARD

Instructional programs from pre-kindergarten through grade 12 should enable all students to:

- *Understand measurable attributes of objects and the units, systems, and processes of measurement.*
- *Apply appropriate techniques, tools, and formulas to determine measurements.*

Grades 3 - 5 Expectations: In grades 3 - 5 all students should:

Understand measurable attributes of objects and the units, systems, and processes of measurement.

- *Understand such attributes as length, and select the appropriate type of unit for measuring each attribute.*
- *Understand the need for measuring with standard units and become familiar with standard units in the customary and metric systems.*
- *Carry out simple unit conversions, such as from centimeters to meters, within a system of measurement.*
- *Understand that measurements are approximations and how differences in units affect precision.*

DATA ANALYSIS AND PROBABILITY

Instructional programs from pre-kindergarten through grade 12 should enable all students to:

- *Formulate questions that can be addressed with data and collect, organize, and display relevant data to answer them.*
- *Select and use appropriate statistical methods to analyze data.*
- *Develop and evaluate inferences and predictions that are based on data.*
- *Understand and apply basic concepts of probability.*

Grades 3 - 5 Expectations: In grades 3 - 5 all students should:

Formulate questions that can be addressed with data and collect, organize, and display relevant data to answer them.

- *Collect data using observations, surveys, and experiments.*
- *Represent data using tables and graphs such as line plots, bar graphs, and line graphs.*

Grades 3 - 5 Expectations: In grades 3 - 5 all students should:

Select and use appropriate statistical methods to analyze data.

- *Describe the shape and important features of a set of data and compare related data sets, with an emphasis on how the data are distributed.*

Grades 3 - 5 Expectations: In grades 3 - 5 all students should:

Develop and evaluate inferences and predictions that are based on data.

- *Propose and justify conclusions and predictions that are based on data and design studies to further investigate the conclusions or predictions.*



GRADES 6 - 8

NUMBERS AND OPERATIONS

Grades 6 - 8 Expectations: In grades 6 - 8 all students should:

Understand numbers, ways of representing numbers, relationships among numbers, and number systems.

- *Work flexibly with fractions, decimals, and percents to solve problems.*
- *Develop meaning for percents greater than 100 and less than 1.*
- *Understand and use ratios and proportions to represent quantitative relationships.*
- *Develop meaning for integers and represent and compare quantities with them.*

Grades 6 - 8 Expectations: In grades 6 - 8 all students should:

Understand meanings of operations and how they relate to one another.

- *Understand the meaning and effects of arithmetic operations with fractions, decimals, and integers.*

Grades 6 - 8 Expectations: In grades 6 - 8 all students should:

Compute fluently and make reasonable estimates.

- *Select appropriate methods and tools for computing with fractions and decimals from among mental computation, estimation, calculators or computers, and paper and pencil, depending on the situation, and apply the selected methods.*
- *Develop, analyze, and explain methods for solving problems involving proportions, such as scaling and finding equivalent ratios.*

ALGEBRA

Instructional programs from pre-kindergarten through grade 12 should enable all students to:

- *Understand patterns, relations, and functions.*
- *Represent and analyze mathematical situations and structures using algebraic symbols.*
- *Use mathematical models to represent and understand quantitative relationships.*
- *Analyze change in various contexts.*

Grades 6 - 8 Expectations: In grades 6 - 8 all students should:

Understand patterns, relations, and functions.

- *Represent, analyze, and generalize a variety of patterns with tables, graphs, words, and symbolic rules when possible.*
- *Relate and compare different forms of representation for a relationship.*
- *Identify functions as linear or nonlinear and contrast their properties from tables, graphs, or equations.*

Grades 6 - 8 Expectations: In grades 6 - 8 all students should:

Represent and analyze mathematical situations and structures using algebraic symbols.

- *Develop an initial conceptual understanding of different uses of variable.*
- *Explore relationships between symbolic expressions and graphics of lines, paying particular attention to the meaning of intercept and slope.*
- *Use symbolic algebra to represent situations and to solve problems, especially those that involve linear relationships.*
- *Recognize and generate equivalent forms for simple algebraic expressions and solve linear equations.*

Grades 6 - 8 Expectations: In grades 6 - 8 all students should:

Use mathematical models to represent and understand quantitative relationships.

- *Model and solve contextualized problems using various representations, such as graphs, tables, and equations.*

Grades 6 - 8 Expectations: In grades 6 - 8 all students should:

Analyze change in various contexts.

- *Use graphs to analyze the nature of changes in quantities in linear relationships.*

MEASUREMENT STANDARD

Instructional programs from pre-kindergarten through grade 12 should enable all students to:

- *Understand measurable attributes of objects and the units, systems, and processes of measurement.*
- *Apply appropriate techniques, tools, and formulas to determine measurements.*

Grades 6 - 8 Expectations: In grades 6 - 8 all students should:

Understand measurable attributes of objects and the units, systems, and processes of measurement.

- *Understand both metric and customary systems of measurement.*
- *Understand relationships among units and convert from one unit to another within the same system.*

Grades 6 - 8 Expectations: In grades 6 - 8 all students should:

Apply appropriate techniques, tools, and formulas to determine measurements.

- *Select and apply techniques and tools to accurately find length, area, volume, and angle measures to appropriate levels of precision.*
- *Solve problems involving scale factors, using ratio and proportion.*
- *Solve simple problems involving rates and derived measurements for such attributes as velocity and density.*

DATA ANALYSIS AND PROBABILITY

Grades 6 - 8 Expectations: In grades 6 - 8 all students should:

Instructional programs from pre-kindergarten through grade 12 should enable all students to:

- *Formulate questions that can be addressed with data and collect, organize, and display relevant data to answer them.*
- *Select and use appropriate statistical methods to analyze data.*
- *Develop and evaluate inferences and predictions that are based on data.*
- *Understand and apply basic concepts of probability.*

Grades 6 - 8 Expectations: In grades 6 - 8 all students should:

Formulate questions that can be addressed with data and collect, organize, and display relevant data to answer them.

- *Formulate questions, design studies, and collect data about a characteristic shared by two populations or different characteristics within one population.*
- *Select, create, and use appropriate graphical representations of data, including histograms, box plots, and scatter plots.*

Grades 6 - 8 Expectations: In grades 6 - 8 all students should:

Develop and evaluate inferences and predictions that are based on data

- *Use observations about differences between two or more samples to make conjectures about the populations from which the samples were taken.*
- *Make conjectures about possible relationships between two characteristics of a sample on the basis of scatter plots of the data and approximate lines of fit.*
- *Use conjectures to formulate new questions and plan new studies to answer them.*



Grades 6 - 8 Expectations: In grades 6 - 8 all students should:

Understand and apply basic concepts of probability

- *Understand and use appropriate terminology to describe complementary and mutually exclusive events.*
- *Use proportionality and a basic understanding of probability to make and test conjectures about the results of experiments and simulations.*
- *Compute probabilities for simple compound events, using such methods as organized lists, tree diagrams, and area models.*

PROCESS STANDARDS

Problem Solving

Instructional programs from pre-kindergarten through grade 12 should enable all students to:

- *Build new mathematical knowledge through problem solving.*
- *Solve problems that arise in mathematics and in other contexts.*
- *Apply and adapt a variety of appropriate strategies to solve problems.*
- *Monitor and reflect on the process of mathematical problem solving.*

Reasoning and Proof

Instructional programs from pre-kindergarten through grade 12 should enable all students to:

- *Recognize reasoning and proof as fundamental aspects of mathematics.*
- *Select and use various types of reasoning and methods of proof.*

Communication

Instructional programs from pre-kindergarten through grade 12 should enable all students to:

- *Organize and consolidate their mathematical thinking through communication.*
- *Communicate their mathematical thinking coherently and clearly to peers, teachers, and others.*
- *Analyze and evaluate the mathematical thinking and strategies of others.*
- *Use the language of mathematics to express mathematical ideas precisely.*

Connections

Instructional programs from pre-kindergarten through grade 12 should enable all students to:

- *Recognize and use connections among mathematical ideas.*
- *Recognize and apply mathematics in contexts outside of mathematics.*

Representation

Instructional programs from pre-kindergarten through grade 12 should enable all students to:

- *Create and use representations to organize, record, and communicate mathematical ideas.*
- *Select, apply, and translate among mathematical representations to solve problems.*
- *Use representations to model and interpret physical, social, and mathematical phenomena.*

Standards are reprinted with permission from Principles and Standards for School Mathematics, copyright 2000 by the National Council of Teachers of Mathematics (NCTM). All rights reserved. NCTM does not endorse the content or validity of these alignments.

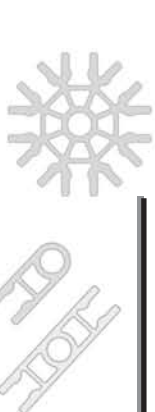

Common Core Standards Alignments

Common Core State Standards for Mathematics in Grades 5 - 9

MATHEMATICAL PRACTICES - ASSOCIATED WITH MATHEMATICS AT ALL GRADE LEVELS

1. *Make sense of problems and persevere in solving them*
2. *Reason abstractly and quantitatively.*
3. *Construct viable arguments and critique the reasoning of others.*
4. *Model with mathematics.*
5. *Use appropriate tools strategically.*
6. *Attend to precision.*
7. *Look for and make use of structure.*
8. *Look for and express regularity in repeated reasoning.*

GRADE 5

Operations and Algebraic Thinking

- *Write and interpret numerical expressions.*
- *Analyze patterns and relationships.*

Number and Operations in Base Ten

- *Perform operations with multi-digit whole numbers and with decimals to hundredths.*

Measurement and Data

- *Convert like measurement units within a given measurement system.*
- *Represent and interpret data.*

Geometry

- *Graph points on the coordinate plane to solve real-world and mathematical problems.*

MATHEMATICS GRADE 6

In Grade 6, instructional time should focus on four critical areas:

- *Connecting ratio and rate to whole number multiplication and division and using concepts of ratio and rate to solve problems.*
- *Writing, interpreting, and using expressions and equations.*
- *Developing understanding of statistical thinking.*

GRADE 6

Ratios and Proportional Relationships

- *Understand ratio concepts and use ratio reasoning to solve problems.*

The Number System

- *Compute fluently with multi-digit numbers and find common factors and multiples.*

Expressions and Equations

- *Apply and extend previous understandings of arithmetic to algebraic expressions.*
- *Reason about and solve one-variable equations.*
- *Represent and analyze quantitative relationships between dependent and independent variables.*



Statistics and Probability

- *Develop understanding of statistical variability.*

MATHEMATICS GRADE 7

In Grade 7, instructional time should focus on four critical areas:

- *Developing understanding of and applying proportional relationships.*
- *Developing understanding of operations with rational numbers and working with expressions and linear equations.*
- *Drawing inferences about populations based on samples.*

GRADE 7

Ratios and Proportional Relationships

- *Analyze proportional relationships and use them to solve real-world and mathematical problems.*

The Number System

- *Apply and extend previous understandings of operations with fractions to add, subtract, multiply, and divide rational numbers.*

Expressions and Equations

- *Use properties of operations to generate equivalent expressions.*
- *Solve real-life and mathematical problems using numerical and algebraic expressions and equations.*

MATHEMATICS GRADE 8

In Grade 8, instructional time should focus on three critical areas:

- *Grasping the concept of a function and using functions to describe quantitative relationships.*

GRADE 8

Expressions and Equations

- *Analyze and solve linear equations.*

Functions

- *Define, evaluate, and compare functions.*
- *Use functions to model relationships between quantities.*

Statistics and Probability

- *Investigate patterns of association in bivariate data.*

Common Core State Standards for Mathematics in High School

NUMBER AND QUANTITY

The Real Number System

- *Use properties of rational and irrational numbers.*

Quantities

- *Reason quantitatively and use units solve problems.*

The Complex Number System

- *Perform arithmetic operations with complex numbers.*

Statistics and Probability

- *Develop understanding of statistical variability.*

MATHEMATICS GRADE 7

In Grade 7, instructional time should focus on four critical areas:

- *Developing understanding of and applying proportional relationships.*
- *Developing understanding of operations with rational numbers and working with expressions and linear equations.*
- *Drawing inferences about populations based on samples.*

GRADE 7

Ratios and Proportional Relationships

- *Analyze proportional relationships and use them to solve real-world and mathematical problems.*

The Number System

- *Apply and extend previous understandings of operations with fractions to add, subtract, multiply, and divide rational numbers.*

Expressions and Equations

- *Use properties of operations to generate equivalent expressions.*
- *Solve real-life and mathematical problems using numerical and algebraic expressions and equations.*

MATHEMATICS GRADE 8

In Grade 8, instructional time should focus on three critical areas:

- *Grasping the concept of a function and using functions to describe quantitative relationships.*

GRADE 8

Expressions and Equations

- *Analyze and solve linear equations.*

Functions

- *Define, evaluate, and compare functions.*
- *Use functions to model relationships between quantities.*

Statistics and Probability

- *Investigate patterns of association in bivariate data.*

Common Core State Standards for Mathematics in High School**NUMBER AND QUANTITY**

The Real Number System

- *Use properties of rational and irrational numbers.*

Quantities

- *Reason quantitatively and use units solve problems.*

The Complex Number System

- *Perform arithmetic operations with complex numbers.*

Objectives

Students will be able to:

- Devise and construct a gravity-powered vehicle of their own design.
- Correctly identify and describe the difference between potential and kinetic energy in a racer/ramp system.
- Design and modify a K'NEX racer for a specific purpose.

Materials

- K'NEX Education Force and Newton's Laws materials, including a variety of wheels
- A 30 cm X 120 cm ramp (cardboard, plywood or hardboard)
- A supply of books to use as ramp supports
- A metric tape
- Adding machine tape
- Masking tape
- Copies of:
 - * The Gravity Design Brief
 - * Student Response Sheets 1-5
 - * The Design Loop
 - * The Egg-citing Design Brief (optional – note that this will require additional materials)

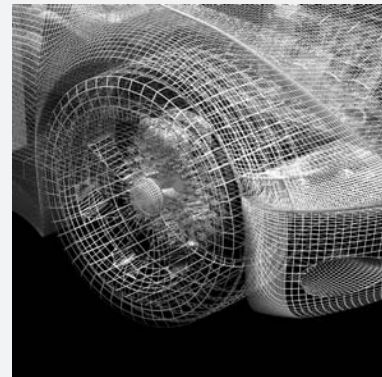

Time
2-3 x 45 minutes

Teacher's Notes

- *This first investigation is an open exploration of vehicle design and vehicle modification, with a focus on the design and construction of a gravity-powered vehicle. Prior to the start of this lesson, students should be made aware of the **design loop** as a viable process for solving design and technology problems. (See *The Design Loop*, Page 17.)*
- *Students will be asked to:*
 1. *Examine the K'NEX Education Rods, Connectors, Wheels, and Hubs that are available in the set.*
 2. *Create a dimensional sketch/plan of a vehicle that could be made from these pieces.*
 3. *Construct the vehicle according to their plans.*
- *Providing time for the students to examine the K'NEX Education materials (excluding the motors and rubber bands) is important, and it is suggested that the different pieces be sorted/categorized to help the selection process once they begin designing and building.*
- *If students have not used K'NEX materials before, you may want to review the Building Tips page from the Building Instruction booklet to demonstrate the ways in which the various Connectors and Rods connect.*
- *This first activity is intended to be completely open-ended and non-directed. It is suggested that students have an opportunity to review the set building instructions if they need some help with starting their planning process.*

PROCESS**ENGAGE**

1. Provide a copy of **The Gravity Design Brief** (Page 28) to students.
2. Review the structure of this challenge, field questions from the students, and set them on task. Note that students should:
 - Submit a design sketch before they gather materials and begin construction.
 - Use the **Student Response Sheet 1: Gravity Inc. Design** to record the top view (plan) and the side view (elevation) of their vehicle, including metric dimensions.
 - Tape these lab pages directly into their science notebooks or journals as an entry in the **observation** section.

EXPLORE

3. Distribute copies of **Student Response Sheet 1** and allow the students to examine the K'NEX Education materials.
4. Design the vehicles:
 - Remind students that they can not start construction until **sketches** are submitted for approval.
5. Build the model:
 - Once their design sketches have been approved, they should gather their K'NEX materials and begin building their vehicles.
 - During this time, encourage students as they translate their design concepts into a three dimensional model.
6. Build the ramps for vehicle testing:
 - Ramps can be made from a variety of materials, including cardboard and plywood, and then elevated using a pile of books or a chair (if the ramp is long enough).
 - To ensure a smooth run, tape a piece of stiff paper to the end of the ramp to serve as a transition with the floor.
 - It is suggested that no instruction or hints be given at this time regarding the optimum ramp height, as this is a variable that the students will investigate later in this unit.
7. Test the vehicles:
 - Measuring distance will be a process performed throughout this unit. For the sake of consistency, establish a standard such as: "All trials are measured from the bottom of the ramp to the center of the rear wheels of the vehicle."

- As an additional aid, students should also be instructed to create **Large Scale Measuring Tapes** by taping about ten meters of adding machine tape to the floor, out from the base of their ramp. This tape can then be marked in one-meter intervals. When the students are measuring the distance their racers traveled they can then easily count the number of full meters, multiply that by 100 to convert to centimeters, and use a metric tape to measure the fractional distance that remains, adding this to the total of full meters. These **Large Scale Measuring Tapes** should be saved and used throughout this unit.

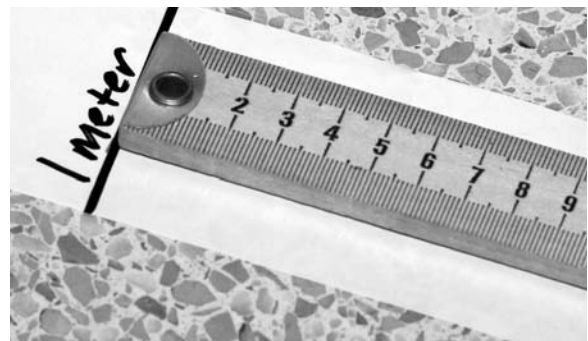
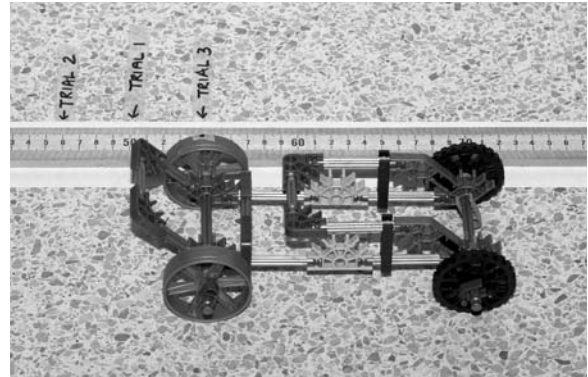

Teacher's Notes

- During this exploration phase students may be tempted to make modifications to their vehicles. Don't discourage this, but ask that they record any changes in writing or through illustrations, along with a reason for the change. This procedure is an important aspect of accurate record keeping and will improve the accuracy of data processing.
- The lesson begins as a challenge-directed experience and evolves into a guided discovery lesson as students pursue the leading questions found on **Student Response Sheets 2 & 3**.

- Distribute **Student Response Sheets 2** and **3** and ask teams to take their investigations further by responding to the leading questions.

EXPLAIN

9. Provide sufficient time for students to complete the questions on **Student Response Sheet 4**.
10. Students report their findings.

Teacher's Notes

- *If working with groups of students, It is important for students to share their procedures and results (Q6) as the diversity of thinking is beneficial for enhancing the problem-solving repertoire of each student. Sharing is not only encouraged, it is a strategy used throughout the program.*

ELABORATE AND EVALUATE

11. Students should attempt to find answers to additional questions regarding possible variables or queries that they have raised during the previous phases of this investigation. Many of these challenges require the students to apply the knowledge they gathered earlier in the lesson.

Potential and Kinetic Energy**ENGAGE**

12. Discuss with the students what they have discovered about the K'NEX racers, such as how they move, and the effect of selected variables on the efficiency of racer movement, including ramp adjustments.

EXPLORE

13. Introduce the concept of **potential and kinetic energy**:
 - Set up two ramps, both observable to the class, one with a ramp height of 10 centimeters, the other with ramp height of 60 centimeters.
 - Distribute copies of **Student Response Sheet 5** for recording purposes.
 - Hold a racer at the top of the ramp with the shallow angle and release it.
 - Ask, "**Why did the racer roll down the ramp?**" (*The force of gravity pulled the racer down the ramp.*)
 - Have the students record their responses on their response sheet and then ask them to share their thoughts.
 - Field student responses, making sure to record them.
 - Repeat the process for the second ramp.

**EXPLAIN**

14. Use probing questions to help students complete **Response Sheet 5**:

- “Why were the results of the two racer trials different?”
(*The ramp angle was steeper for one racer and it went down the ramp faster than the other racer.*)
- “What rule could you make that would describe what you observed?”
(*The steeper the ramp angle the faster the racer will go.*)
- “How could you rephrase that rule to include the word energy?”
(*The steeper ramp gives the racer more energy.*)
- Have the students share their rephrased rules.

15. Explain that there are two terms that are used to describe the energy in the racer/ramp system, **potential energy** and **kinetic energy**.

- Potential energy is the **energy of position** and can also be referred to as stored or future energy.
- Kinetic energy is referred to as the **energy of motion**.

EVALUATE

16. Have the students label the sketch at the bottom of the response sheet with the terms **Potential Energy** and **Kinetic Energy**.

Teacher's Notes

- **Potential energy** has two basic forms, **gravitational potential energy** and **elastic potential energy**.
- In the case of gravitational energy, the mass of an object and the height of the object from the surface of the earth are directly related to the amount of gravitational potential energy the object possesses. The greater the mass and/or the higher the object, the greater the potential energy since gravity is constant. Gravitational potential energy can be expressed by the formula:

$$PE = \text{mass} * g * \text{height} \quad \text{or} \quad PE = m * g * h$$

Symbol	Description	Unit	Symbol
PE	Potential Energy	Joules	J
m	mass	Kilogram	K
g	acceleration due to gravity	Meters/Sec/Sec	m/s/s or m/sec ²
h	height	Meters	m

In this formula, **PE** stands for potential energy, **m** is equal to mass, **g** stands for the acceleration due to gravity, and **h** represents the height of the object from the surface of the earth. For the purposes of the investigations provided in the K'NEX Education Teacher's Guide, the floor will be considered the level at which gravitational potential energy reaches zero.

- The second form of potential energy is elastic potential energy and is the energy stored in materials as they are twisted, stretched or compressed. This concept is somewhat intuitive as the more a material is twisted, stretched or compressed, the more stored energy it contains. Several racer models in this set make use of this concept as rubber bands and springs are employed as energy sources.
- **Kinetic energy** is the energy of motion. While there are numerous forms of kinetic energy, the activities in this manual address only **transitional kinetic energy** - the energy of motion from one location to another. The amount of transitional kinetic energy is related to the mass of the object and the speed at which it is traveling.
- The formula for determining kinetic energy is: $KE = \frac{1}{2} mv^2$.
In this formula **m** represents the mass of the object and **v** is equal to the object's velocity (speed).
- You may want to extend the concept of potential and kinetic energy by presenting the **Egg-citing Design Brief**. This investigation challenges students to design a passive restraint system to prevent a raw egg from breaking when the vehicle containing it crashes into a wall.



The Design Loop

The Design Loop represents a basic strategy for solving problems. Ideas can originate from anywhere because the circle can be entered from any location. As the students design, construct, and test the various K'NEX Education racers in this unit, they may also find that changes or modifications may be necessary. The students should also understand that the process of “backtracking” is common and, in some cases, an essential practice in problem solving. For example, when they make changes to their vehicles, tests may prove that their modifications did not produce the expected results and they have to “backtrack” to select another option.

Consider making copies of this diagram for students to use as a student notebook entry.

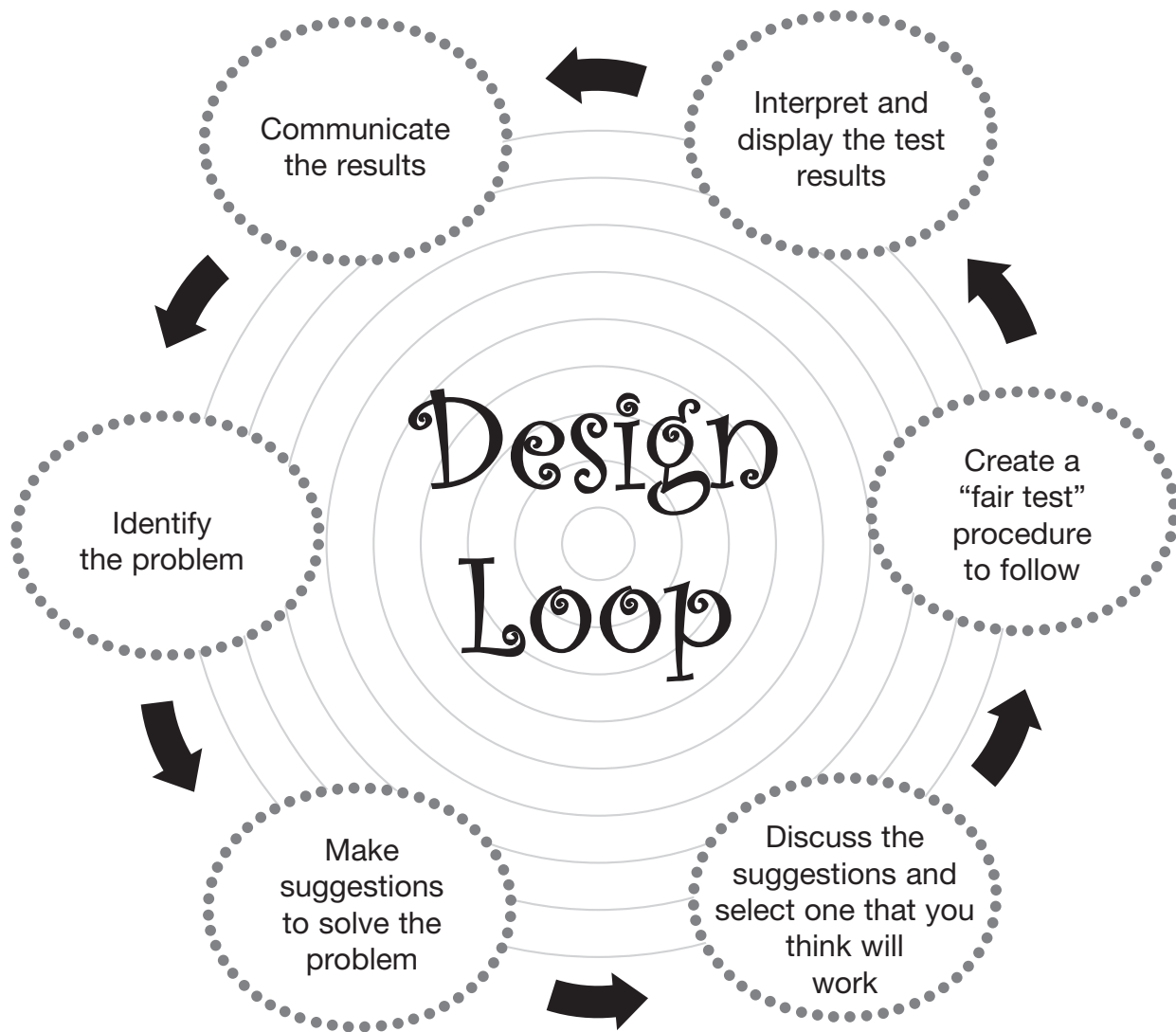

DILEMMA IN DETROIT: DESIGNING VEHICLES



The Gravity Design Brief

The Context:

To stay competitive, manufacturers must change products to meet changing demands.

The Scenario:

As gasoline prices continue to rise, alternative energy sources for vehicles are becoming more popular. The Gravity Automobile Company Inc. is looking to capitalize on this trend and establish itself as a front-runner in the hybrid car business.

The Challenge:

The Gravity Automobile Company Inc. is seeking new engineers to design and construct gravity-powered test vehicles that are capable of traveling in a straight line for a distance of six meters.

The Limitations:

- Vehicle illustrations must be submitted before gathering construction materials.
- Illustrations must be both top view and side view projections.
- Design may only use the K'NEX materials provided.

The Rules:

- All test data must be recorded in the data chart on Student Response Sheet 1
- Students are expected to make and test two different modifications to their vehicles.
- All changes and test data **must** be recorded.



Gravity Automobile Company Inc. Design

VEHICLE DESIGN

Top View

Side View

EXPLORE

- Build a vehicle to match your design sketch.
- Let your vehicle roll down a ramp (without pushing it). Measure the distance it travels from the bottom of the ramp.
- Make three trials with your vehicle and record your data in the chart below your sketches.

OBSERVATIONS

Design Type	Distance Vehicle Travels in Centimeters			
	Trial #1	Trial #2	Trial #3	Average
Original Design				
Modified Design #1				
Modified Design #2				

DILEMMA IN DETROIT: DESIGNING VEHICLES



EXPLORE

- Use your original design or modified vehicle to answer this question:

Does wheel size make a difference to the distance the vehicle travels?

- To have a “fair test” be sure that you do not change anything **except the size of the vehicle’s wheels**, so make certain, for example, that you start each test at the same place on the ramp.
- Carefully record your data.

OBSERVATIONS

Distance Vehicle Travels in Centimeters				
Size of Wheels	Trial #1	Trial #2	Trial #3	Average
Small				
Large				

- Please describe what you found:

EXPLAIN

- Predict what would happen to the distance your vehicle travels if you were to double the size of the largest wheels. Please explain.

PREDICTION:

EXPLANATION:

- Consider a vehicle that has small tires on the front and large tires on the rear. If the front tires were also changed to the large sized tires, would the distance traveled by the vehicle change? Please explain your answer.



Student Response Sheet

3

Name: _____

Date: _____

DILEMMA IN DETROIT: DESIGNING VEHICLES

EXPLORE

1. Use your original design or modified vehicle to answer this question:

Does the height of the ramp make a difference to the distance the vehicle travels?

- To have a “fair test” be sure that you do not change anything except the height of the ramp.
- Carefully record your data.

Distance Vehicle Travels in Centimeters				
Height of Ramp in Centimeters	Trial #1	Trial #2	Trial #3	Average

2. Please describe what you found:

EXPLAIN

3. What ramp height would you recommend to others if they wanted their vehicles to travel the greatest distance? Use your data to support your answer.

4. What other things do you think you could do to make your vehicle go further?



ELABORATE

On Your Own:

1. Choose one or more of the following questions to investigate. Briefly prepare a justification for your choice.
 - Will a heavy vehicle roll further than a light vehicle?
 - Does the starting location on the ramp affect the distance a vehicle will travel?
 - Does the length of the vehicle affect how far the vehicle will travel?
 - Do wider wheels affect the distance a vehicle will travel?
2. Be sure you design **and describe** a “fair test” by keeping everything the same, except the variable you are testing. Design a data chart of some kind, report the results, and make recommendations about what you found.
3. What is the question your team will investigate?
4. What is your procedure? What steps will you follow in answering this question?
5. What variables will you hold constant?
6. What variable will you measure?



Student Response Sheet

4

Name: _____

Date: _____

7. Show how you will display your data.

8. Describe your results.

9. What recommendations would you make to The Gravity Automobile Company Inc. to increase the distance their vehicles will travel? Please support your answer using the data you collected.

EVALUATE

10. What question/questions about the distance a vehicle will travel do you now have?

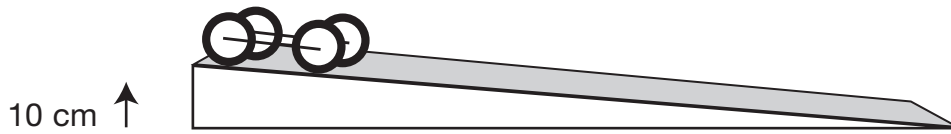

1. Why does the racer roll down the ramp?

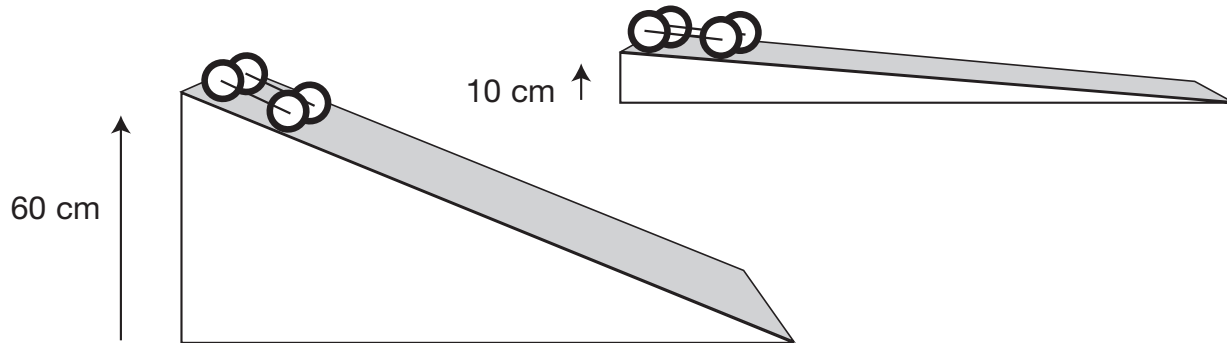

2. How does the movement of the second racer compare to that of the first racer?

3. Why do you think the racers seem to move at different speeds?

4. Make up a rule that explains what you observed.

5. Rewrite the rule to include the term **energy**.



Student Response Sheet

5

Name: _____

Date: _____

6. The sketch below shows the same racer in two locations, (a) resting at the top of the ramp and (b) moving toward the bottom of the ramp. Label the sketch below with the terms **Potential Energy (stored energy)** and **Kinetic Energy (moving energy)**.

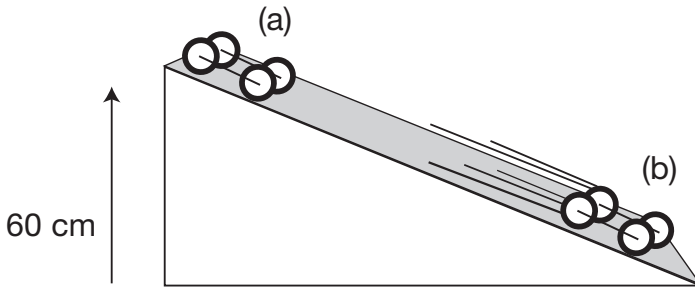

Explain the difference between potential and kinetic energy:



The Context:

It's not going fast that will injure the passengers in a car... it's the sudden stop.

The Scenario:

The vehicles in which we travel contain many safety features that have saved lives. In an effort to be more proactive, the National Highway Traffic and Safety Administration has recently decided to increase the safety standards that automobile manufacturers must meet.

The Challenge:

As a member of an automotive engineering team you have been assigned the responsibility of improving the overall safety of the company's cars. You believe that the current restraint system of the vehicles needs to be revised, especially since the testing procedures have been upgraded and more sensitive raw eggs will be used instead of the standard electronic dummy.

The Limitations:

- Submit a detailed action plan before modifying your vehicle.
- You will have access to the general supply of K'NEX materials; additional materials are your responsibility.
- During the research and development phase, use imitation eggs.
- Raw eggs, in plastic bags, will be used for the final test.

The Rules:

- All ramps will be 120 cm long and must be maintained at a ramp height of 30 centimeters. The lower end of the ramp will be butted against a wall.
- Detailed sketches must accompany each final report. The terms **potential** and **kinetic energy** must be used in the explanation of how the restraint system functions.
- During final testing all eggs must be housed inside a plastic bag.
- Evaluation and rating of the restraint system after the final test run is as follows:
 - EXCELLENT:** The shell is not cracked and the yolk is unbroken.
 - GOOD:** The shell cracked but the yolk is unbroken.
 - POOR:** The shell not cracked but the yolk is broken.
 - UNACCEPTABLE:** The shell cracked and the yolk is broken.
- Prepare a final report that details the safety features implemented, how the testing was conducted, and the results of this testing. Reports must also include additional safety recommendations that might be considered.

Lesson 2

ROLLING, ROLLING, ROLLING...



Time to Build:
10 minutes

Length of Lesson:
45 minutes

Design Brief:
2-3 x 45 minutes

Objectives

Students will be able to:

- Infer that the elasticity of a rubber band can change with use and alter the potential energy of a device.
- Design and conduct investigations with the Rolling Racer.
- Collect, organize, graph, and interpret investigative data.
- Appropriately apply the concept of inertia.

Materials

- K'NEX Education Force and Newton's Laws materials
- Building Instructions Booklet Page 5: Rolling Racer
- #32 rubber bands
- Ramp
- Different sized K'NEX Hubs and Tires
- Student Response Sheet 6

PROCESS

ENGAGE

1. Construct a Rolling Racer and wrap some paper around the center to form a tube so that the rubber band is hidden. Tape the paper in place. The end of the Rolling Racer, opposite the crank arm, should also be covered. Wind up the racer and hold onto it until you are ready to show the students.
2. Ask the students to describe their experiences with the prior design challenges. For example: **“What variables did you find were the most effective in increasing the rolling distance of the gravity powered vehicle?”**
Field the students' responses, pausing from time to time while asking them to clarify their comments with supportive data and evidence.
3. Hold up the Rolling Racer and ask them to speculate how far this vehicle might travel. Field responses, again asking students to provide a rationale for their answers.
4. Have the students set up a ramp at the height they suggested to be the most efficient. Before placing the Rolling Racer on the ramp, (which is really not your intention) make an excuse for putting it down on a level surface such as a tabletop or the floor. (*For example: The need to adjust the ramp.*) The Racer will move across the floor on its own, powered by energy in the wound-up rubber band.

EXPLORE

5. Ask the students to infer what might be inside of the Rolling Racer that would make it appear to move on its own.
6. After the students have shared their ideas, provide only the necessary K'NEX materials and instructions to construct their own working model of the Rolling Racer.
7. Invite them to investigate the device to see if the number of windings of the rubber band affects the distance the Rolling Racer travels.
8. Distribute copies of **Student Response Sheet 6** for recording purposes.

EXPLAIN

9. Students will craft a rule summarizing their explorations into the relationship between the number of rubber band twists and the distance the Rolling Racer traveled.

Teacher's Notes

Discovering Inertia

- *As the students explore the Rolling Racer they will find that the device requires a minimum number of twists before it begins moving. Explain that the Rolling Racer, like most other objects that move, requires some effort to get started.*
- *This tendency of objects at rest to remain at rest and objects in motion to remain in motion is known as **inertia** and is **Newton's First Law of Motion**. The Rolling Racer will remain at rest until the rubber band has stored enough potential energy to overcome the inertia of the Racer.*
- *The amount of inertia of an object is related to its mass. The greater the mass, the more effort is needed to overcome the resting inertia. The same is true of moving inertia - the greater the mass of a moving object, the greater the effort required to stop the object. Students can get a better "feel" for this concept if you include demonstrations that require them to move, or stop, relatively heavy objects such as a person sitting in a roller chair in the gymnasium, or someone on a skate board.*

ELABORATE

10. After discussing the concept of **inertia**, ask the students to determine the minimum number of twists of the rubber band that are required to start the Rolling Racer moving.
Results may vary depending on the floor surface and the age (amount of use) of the rubber band.
11. It is expected that students will apply prior knowledge to formulate and test additional ways to **increase the distance** the Rolling Racer will travel.
12. Students will also be expected to create their own data chart to display the data they collect.

Teacher's Notes

- As students design ways to increase the distance the vehicle will travel, they may investigate:
 - * changing the length of the Rod used to wind the model
 - * adding pieces to the system
 - * adding rubber bands to the system
- The Rolling Racer does include a safety feature that may limit some of their tests. The rubber band is connected to a purple Connector. This will slip on the Blue Rod, to which it is attached, if too much force is applied by over-winding, or if the rubber bands are too small or too stiff.

EVALUATE

13. Students will use the information they've gathered during their prior investigations to individually craft directions for a Racer that would be the greatest traveler. Students must also include a labeled, color illustration.

Teacher's Notes

- It is assumed that students will be able to compute the mechanical advantage of the different sized drive wheels that could be used on the Rolling Racer (and subsequent racers).
- If this is not the case and you would prefer to include this as part of the overall experience, have them use the following formula to compute the mechanical advantage:

$$MA = \frac{\text{Radius of the Axle}}{\text{Radius of the Wheel}}$$

OR

$$MA = \frac{\text{Distance Around the Axle}}{\text{Distance Around the Wheel}}$$

In the wheel and axle system the force is being applied to the axle so the mechanical advantage is less than one (1) but the speed of the wheel, and thus the distance the wheel travels, is increased.



EXPLORE

1. Use your Rolling Racer model to answer this question:

Does the number of rubber band windings affect the distance the Rolling Racer will travel?

- Wind your Rolling Racer five complete turns, place it on the floor and measure how far it travels. Make two more trials and compute the average.
- Complete Data Table 1 making sure to **skip 15, 30, and 40** windings.

DATA TABLE 1

Distance Vehicle Travels in Centimeters				
Number of Rubber Band Windings	Trial #1	Trial #2	Trial #3	Average
5				
10				
15 (SKIP)				
20				
25				
30 (SKIP)				
35				
40 (SKIP)				
45				
50				

EXPLAIN

2. Make up a rule that describes what you found out about the number of rubber band windings and the distance the Rolling Racer traveled.
3. On the graph on the next page, or on graph paper provided by your teacher:
 - (i) Number the **X**-axis in increments of 5 (E.G., 0, 5, 10 etc.) and the **Y**-axis in increments of 1 (E.G., 0, 1, 2, 3 etc.)
 - (ii) Title the **X**-axis: **Number of Windings** and the **Y**-axis: **Distance in Centimeters**.
 - (iii) Transfer your data from Data Table 1 to your graph.

ROLLING, ROLLING, ROLLING...



GRAPH

Y

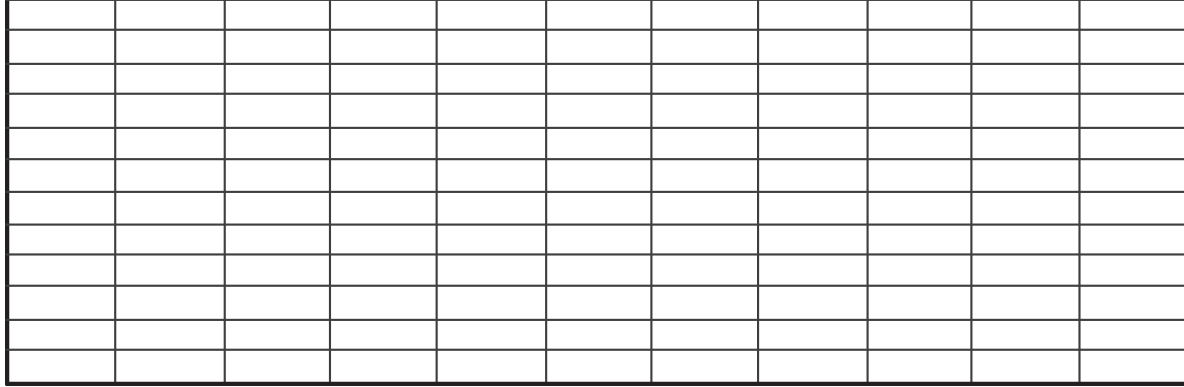

X

- Use your graph to predict the distance you think the Rolling Racer would have traveled if it had been wound up 15, 30, and 40 turns. Record your predictions in Data Table 2.

DATA TABLE 2

	Predicted Distance	Actual Distance
15 turns		
30 turns		
40 turns		

- Test your predictions and record the actual distances in Data Table 2.

ELABORATE

- Instead of adding more rubber band windings, there may be other things that could be done to increase the distance that the Rolling Racer travels. Please list at least two alternatives and give reasons why you think they may work.

(i)

(ii)



7. Build and test your two alternatives for increasing the distance the Rolling Racer travels. Create a data chart below to display your results.

EVALUATE
On your Own

8. Write out the directions for building a Rolling Racer that will travel further than anything yet tested. Include consumer information describing how much effort is needed to overcome the resting inertia of the new design. Use your test data to support your claims. Include a color illustration with labels.

PART I - Comparing Racers



Time to Build:
15 minutes

Length of Lesson:
3 x 45 minutes

Design Brief:
45 minutes

Objectives

Students will be able to:

- Correctly identify and describe the difference between potential and kinetic energy in a rubber band racer system.
- Design and conduct a “fair test” investigation.
- Design an appropriate data display format.
- Apply concepts to a novel situation.

Materials

- K’NEX Education Force and Newton’s Laws materials
- Building Instructions Booklet Pages 8-11: Rubber Band Racers
- # 32 rubber bands
- Copies of:
Student Response Sheets 7 and 8
Design Brief: ‘On the Surface’

PROCESS

ENGAGE

1. Review the building instructions for each version of the Rubber Band Racer, and ask the students to:
 - Describe the energy source that powers these vehicles, using the term potential energy.
 - Describe the expected action of these vehicles after the rubber band is wound and the car is released on the floor, using the terms potential energy and kinetic energy.
 - Speculate which vehicle they think would travel the furthest, given the same amount of potential energy (rubber band windings).
 - Field student responses, asking them to explain or clarify their answers. This discussion can serve as a **formative assessment** to determine if students are applying information from previous investigations in an appropriate manner and using appropriate science vocabulary as they make responses.

EXPLORE

2. Ask the students to create a “fair test” procedure to determine which racer will travel further, given the same number of rubber band windings.

3. Distribute **Student Response Sheet 7** and provide time for individual students to complete responses on the top of the page before allowing the students to form their teams to complete the bottom of the page.
4. In addition to the procedure, the students are also responsible for crafting an appropriate data display.
5. Remind students that they will have to build and test each model separately for this activity.

Teacher's Notes

- *The procedure outlined above for **Student Response Sheet 7** provides an opportunity for you to gather assessment data on both individual student thoughts and group decisions related to the activity.*

6. Distribute the K'NEX Education materials and Instruction Booklets. Invite the students to construct the racers and begin their investigation.

Teacher's Note

- **CAUTION:** *The wide rear tires of the racers can be moved in and out on their plastic hubs. If moved inward far enough they will contact the racer frame and significantly reduce the efficiency of the racer. Be sure to make students aware of this.*

EXPLAIN

7. Lead a discussion that allows students to report the results of their racer comparison study.
8. Distribute **Student Response Sheet 8** and ask them to **individually** speculate on:
 - Why the results turned out as they did.
 - What variables may have contributed to the difference.

As the students respond, record the possible variables on the chalkboard, chart or overhead projector.

9. Have the students use each variable as an investigation question. For example: tire size – **“Does the size of the rear tires make a difference to the distance the racer travels?”**
10. Students will use Student Response Sheet 8 to guide them as they design and conduct a “fair test” investigation and report their findings to the whole class.

ELABORATE

11. Once the students have collected and processed their data, ask them to extend this experience by designing an optional investigation to verify the findings.

EVALUATE

12. Invite students to:
 - Apply their findings from the rubber band investigations to the manufacture of actual vehicles. You may want to assign the **On The Surface Design Challenge** in which students are asked to design and conduct an investigation to determine if the surface on which a racer travels affects the overall distance it moves.

EXTEND

13. This activity could be extended by asking students to:
 - Design a racer that would stop between two predetermined spots, such as 300 cm. and 330 cm.
 - Design a racer that would travel a long distance, but do so very slowly.

Teacher’s Notes

- *If your students have had little or no experience in designing controlled investigations (fair tests), it is suggested that you take a few minutes to walk them through this process. Students generally have a better understanding of “fairness” than they do of “controlled”. It is for this reason that the former of these two terms is used throughout this manual, beginning in Lesson #2.*
- *Summarizing, a “fair test” is one where all factors or variables are kept the same, except for the one that is to be tested or changed. In the case of our rubber band racers, the students will be asked to determine why the racers did not travel the same distance, even though they received the same amount of energy (rubber band windings).*
- *The intent of this investigation is as much a **formative assessment** for the teacher to determine how the students grapple with the concept of designing a “fair test” procedure as it is an instructional opportunity to teach this process. If you feel that your students already have the knowledge to handle this process, invite them to proceed with their investigations. If, on the other hand, you believe they may benefit from direct instruction, use the **SAMPLE “FAIR TEST” INVESTIGATION** (Page 53) to walk the students through the process. As students design their procedure it is important that their progress be observed and guided.*

Teacher's Notes

- *Students are also required to construct their own data display or data chart. Students have already used examples of appropriate data displays in Lessons #1 and #2. If they experience difficulty with this process, refer them to previous data displays, keeping in mind the labels, the number of trials, and the concept of averaging.*
- *As students work their way through the investigations in this manual they will be expected to take increasing responsibility for crafting more of the components associated with "fair test" investigations.*



Student Response Sheet

7

Name: _____

Date: _____

Comparing Racers

EXPLORE

On Your Own

1. Write out what you believe to be a “fair test” procedure for testing which vehicle would travel further. Be sure to include all the factors (variables) that you feel need to be kept the same.
2. Provide your personal version of an appropriate data display.
3. Craft a procedure for answering the problem. What factors (variables) have you decided to keep the same and how you will keep the constant? You must also construct a data display of some kind to show the data you collect.



**EXPLAIN
On Your Own**

1. What reasons can you give to explain the difference in travel distance between the large and the small rubber band racers?

2. Rewrite three of these reasons in question form.
 - (i)

 - (ii)

 - (iii)

3. Which question will you try to answer? (It may be assigned by your teacher.)

4. Write out a “fair test” procedure that will help you answer this question. Be sure to include the variables you need to keep constant.



Student Response Sheet

8

Name: _____

Date: _____

5. Design a data display for collecting information about your experiment.

6. Describe the results of your investigation.

ELABORATE

7. What do you think you could do to verify your investigation?

8. Conduct your verification experiment, collect and display your data, and write out the results.



EVALUATE

9. The gasoline in an automobile and the rubber band in your racer are both energy sources. Based upon your results, what recommendations would you make to an automobile manufacturer to increase the maximum travel distance of their vehicles? Write a letter to the CEO of the Lightning Bolt Car Company with your suggestions as to how the company could increase the **maximum travel distance** of their vehicles. Be sure to explain why you've made these recommendations. Data displays would help communicate your recommendations.



'On the Surface' Design Brief

The Context

Not all road surfaces are the same, but does this make a difference in racer performance?

The Scenario

Wingnut Automotive Testing, Inc. has been asked by a major automobile manufacturer to collect data regarding the performance of its racers on different surfaces. The company would like to use the very best data in advertising its racers, including whether or not different track surfaces alter vehicle performance.

The Challenge

You are a member of the Wingnut Research Team and crafting a solution to this problem has fallen directly onto your desk. You realize that a fair test must be designed and conducted so that your customer, the car manufacturer, will be able to use your results honestly in their advertising campaign.

The Limitations

- Write out a “fair test” plan of action prior to gathering materials.
- Create a problem question to answer.
- Identify the variables they will hold constant.
- Identify the dependent and independent variables.

The Rules

- Test at least three different surfaces.
- All measurements must be made in centimeters.
- All tests must contain at least three trials and averages must be computed.
- You must create an appropriate data display.
- Write a report to your boss, the President of Wingnut Automotive Testing, Inc., explaining what you did and the results of the testing procedure. Data supported recommendations regarding the best surface to use for advertising should also be included.



Sample "Fair Test" Investigation

EXPLORE

1. Write out what you believe to be a "fair test" procedure for testing which vehicle would travel further. Be sure to include all the factors that you feel need to be kept the same.

Sample Student Response

I think we can find out which racer will go further by testing them. We first need to build each racer by following the K'NEX Education Building Instructions. Once constructed, we will attach a new rubber band to each racer in the same way. Then we will be ready to start the test.

We will need a flat place to test the racers such as the back of the room, or the hallway, or the cafeteria. We can use a piece of tape to mark out a starting line for the racers.

Each racer has to get the same amount of energy so we will wind up the rubber band two complete turns. We will be able to tell the number of complete turns we make because we will mark the side of the rear wheel at the point where it touches the floor when the rubber band is attached to the purple Connector on the axle (but not wrapped around the axle).

To make things fair we will start each racer from the same spot and measure its distance (in centimeters) in the same way. We will measure the distance the rear wheel travels. We will measure the rear wheel from the spot where it touches the floor. Each racer will get two complete windings and we will make three trials and obtain an average distance for each racer.

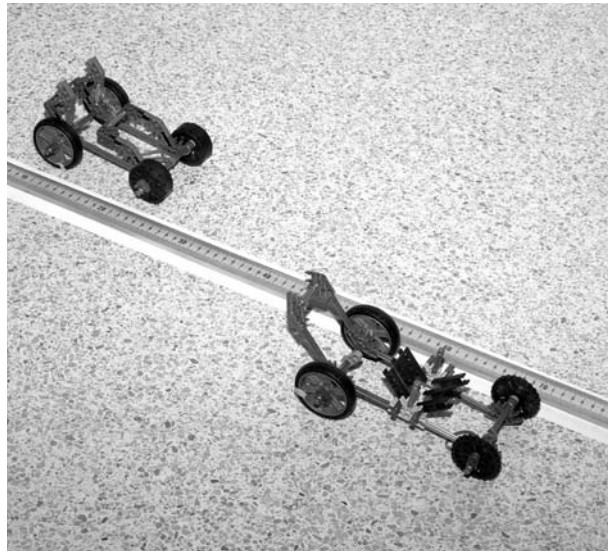

DISTANCE THE RACERS TRAVELED IN CENTIMETERS

Racers	Trial #1	Trial #2	Trial #3	Average
Large Racer				
Small Racer				

PART II - Investigating Weight



Time to Build:
15 minutes

Length of Lesson:
1 x 45 minutes

Objectives

Students will be able to:

- Design and implement a “fair test” investigation.
- Craft a data display and complete an appropriate graph.
- Design and implement project modifications and predict outcomes.

Materials

- K’NEX Education Force and Newton’s Laws materials
- Building Instructions Booklet Pages 10-11: Rubber Band Racer with Mass Holder
- Rolls of pennies (20 per roll) or standard mass sets
- Metric tapes
- Graph paper

Teacher’s Notes

- Pennies minted prior to 1982 weigh 3.1 grams. In 1982 the Federal Government changed the composition of the coins and they now weigh 2.5 grams. Students will be asked to manipulate data at the end of this lesson. It would, therefore, be helpful if all the pennies used were post 1982.

PROCESS

ENGAGE

1. Ask the students to review the results from the previous activity in which they investigated some of the variables affecting the distance a rubber band powered vehicle traveled. One variable may have been the weight of the vehicle. Explain that this will be the focus of the following activity. If this variable was not investigated, rephrase the statement into a question for the students to answer. (i.e., **Will a heavier car travel further than a lighter car?**)



2. Distribute copies of **Student Response Sheet 9** and ask the student to:
 - Write a general rule describing what they think will happen to the distance a vehicle will travel if more and more weight is added.
 - Write out their own version of the problem question to be answered.
3. Have students:
 - Decide upon a version of this question.
 - Make modifications to their individual response sheets, if necessary.

EXPLORE

4. Student teams are expected to:
 - Design a “fair test” investigation to answer the problem question. This should be a variation of, **“Does the amount of weight affect the distance a vehicle will travel?”**
 - Identify the variables they will hold constant.
 - Design a data display.
 - Construct a graph of the results.
 - Interpret the results by crafting a rule that answers the problem question.

Teacher's Notes

- *While this investigation is a relatively open-ended activity, it is critical that students keep the energy (rubber band windings) consistent in all trials. Be sure that you check for this control.*

EXPLORE

5. After the students have worked to construct a graph of their data, they are expected to explain and interpret the investigation “on their own.” As they complete this portion of the investigation you will be able to gather assessment data from their explanation and interpretation.

ELABORATE

6. In this segment the students will be responsible for suggesting and justifying additional vehicle modifications.

EVALUATE

7. Students should compare and contrast suggested vehicle modifications for the purpose of selecting one as the focus for further testing.



Investigating Weight

PREDICT

1. What do you think will happen to the distance a rubber band powered vehicle travels if more and more weight is added? Why?
2. Write out your version of the problem question that you will try to answer. Use the term **inertia** in your question.
3. Write out the team version of the problem question. Be sure the term **inertia** appears in this question.

EXPLORE

4. Please complete the following:
 - Design a “fair test” investigation to answer the problem question.
 - Identify the variables held constant.
 - Make a data display chart.
 - Construct a graph to display the collected data.
 - Use a roll of pennies (20) for each passenger, up to a maximum of six passengers. Each penny has a weight of 2.5 grams.

Fair Test Investigation

Describe your “fair test” investigation on a separate page.

Data Display

Prepare a chart of your data on a separate page.



Communicating Data

- Make a graph of your data.
- Title your graph: **“Racer Weight and Distance”**.
- Title the X-axis: **“Weight of Passengers (in grams)”** and the Y-axis: **“Distance Vehicle Traveled (in centimeters)”**.
- Number both axes in 50 unit increments (E.G.: 0, 50, 100, 150 etc.)

Prepare your graph on a sheet of graph paper.

EXPLAIN

5(a). Write a statement that explains the results of your investigation. What is your answer to the problem question? Describe any data or trends on your graph that support your answer.

5(b). What was the weight of the vehicle and all six passengers (the Completely Loaded Vehicle or CLV)? Show all your calculations.

5(c). There is a trade-off associated with moving heavier vehicles. What do you think the trade-off is? Use the term inertia and your investigative data to support your statement.



Student Response Sheet

9

Name: _____

Date: _____

ELABORATE - EVALUATE

6. What do you think you could do to the CLV so that it would perform better? Please explain why you think making these modifications will improve the performance of the CLV.

7. Review the different vehicle modifications. Decide which idea might be the most effective, make the changes and retest the CLV to see if you improved its performance. Show the results below.

RUBBER BAND RACERS

Lesson 3

PART III - Adding Energy

Objectives

Students will be able to:

- Accurately collect and process investigative data.
- Compare the amount of rubber band energy with the distance a racer travels.
- Predict experimental outcomes through data processing and interpretation.
- Create an appropriate graph to communicate the results of an investigation.
- Recognize patterns in the collected data.

Materials

- K'NEX Education Force and Newton's Laws materials
- Building Instructions Booklet Pages 10-11: Rubber Band Racer with Mass Holder
- #32 rubber bands
- Metric tapes
- Masking tape
- Stopwatches
- A large area to test models
- Student Response Sheet 10
- Graph paper



Time to Build:
Less than 15 minutes

Length of Lesson:
45 minutes

PROCESS

ENGAGE

1. At the end of the previous activity, the students tried to increase the **carrying capacity** of the completely loaded vehicle (CLV). There are several ways that this could be accomplished and increasing the number of rubber band windings is generally the most expedient. Ask the students to describe what they did and the results of their efforts.
2. Explain that the students' next challenge will be to:
 - Investigate the effect of increasing the racer's energy on the **distance** the vehicle will travel. While it should be obvious that increasing the energy of the racer will increase the racer's distance, the emphasis of this activity is on the collection and the display of accurate data.
 - Formulate a uniform procedure and data display for the purpose of compiling and processing whole class data.

EXPLORE

3. Distribute copies of **Student Response Sheet 10**, then:
 - Ask the students to suggest a problem question.
 - Record their suggestions, and decide on the final wording. Example: **“Does increasing the amount of energy affect the distance a vehicle will travel?”**

Teacher’s Notes

- Prior to the activity, test a racer and one of the rubber bands to determine a maximum number of windings for the activity. Inform students that they will wind the racer no more than that number of windings. For the purposes of the investigation, the maximum number of windings on the data table is six (6).

- Ask what steps they would take to create a “fair test” procedure to answer this question.
 - Record the students’ ideas in outline form, paying particular attention to the variables held constant and the measuring procedures.
4. Once the “fair test” procedure has been established:
 - Explain that they will record their data on the **Data Chart**.
 - Ask students to compute the total averages and interpret the data once the charts are complete.

EXPLAIN

5. Students will be expected to:
 - Process and interpret the data collected.
 - Apply the data to craft a prediction about the distance their racer will travel for an untested amount of energy.
 - Compute the total average for each unit of energy (rubber band winding) investigated.

ELABORATE

6. Using the total averages, students will be expected to:
 - Create a graph that compares the amount of energy, in units, to the distance the racer travels.
 - Draw a line that “best fits” the data.

Teacher’s Notes

- Statistically this “best fit” line would be referred to as the regression line and would be determined through the use of a statistical formula. For our purposes, drawing a line “through” the data points, rather than connecting or linking them, produces an approximation of what could be determined statistically. This line of “best fit” communicates a more realistic interpretation of the collected data.



Adding Energy

EXPLORE

1. What is the problem question?

2. Write out the procedure in your own words.

OBSERVATIONS

DATA CHART

Number of Energy Units (Windings)	Distance Racer Traveled with Increased Energy			
	Trial #1	Trial #2	Trial #3	Average
1				
2				
3				
4				
5				
6				



Student Response Sheet

10

Name: _____

Date: _____

EXPLAIN

3. Write a statement or a rule that answers the problem question.

4. What would you predict the distance for your racer to be if you gave it 3.5 units of energy? Use your data to explain how you decided on this prediction.

ELABORATE

5. Create a graph using the your data.
 - Title your graph “Adding Energy”.
 - Label the X-axis “**Number of Energy Units (Windings)**” and the Y-axis “**Average Distance Traveled (cm)**”.
 - Number the X-axis in 0.5 (half) unit increments (E.G., 0, 0.5, 1, 1.5 etc.) and the Y-axis in 25 cm increments (E.G.: 0, 25, 50, 75 etc.)
 - Plot the Total Average Data and then draw a line that best fits the data points.

Student Response Sheet

10

Name: _____

Date: _____



6. Using the graph, determine how far your racer would travel if it had received 3.5 units of energy?

7. Use your data chart and your graph to predict how far your racer would go if you gave it 7 units (windings) of energy. Write your answer here and then try it.

PART I - Energy Sources

Objectives

Students will be able to:

- Identify the energy sources in different types of devices.
- Design and conduct a “fair test” investigation.
- Create appropriate data displays (charts and graphs).
- Process and interpret data for explaining results and making predictions.
- Process and interpret data to explain results and make predictions.

Materials

- K’NEX Education Force and Newton’s Laws materials
- Building Instructions: Pages 12-17 Spring Racer models (all sizes and styles)
- Metric tape
- Adding machine tape
- Masking tape
- Stopwatch or clock with a second hand
- Student Response Sheets 11 and 12
- Graph paper
- Tractor Pull Design Brief (+ butter tub, string, 10 pennies)



Time to Build:
Less than 15 minutes

Length of Lesson:
45 - 50 minutes

Design Brief:
2 x 45 minutes

PROCESS**ENGAGE**

1. Distribute copies of **Student Response Sheet 11**. This formative assessment asks students the following questions:
 - What energy sources powered the vehicles they investigated in previous activities? (*Gravity, twisted rubber bands, and wound rubber bands.*)
 - How could the power of each source of energy be increased and what effect would the increase have on the vehicles used? (*Answers will vary.*)
 - How is energy transferred from the source to the vehicle? (*Gravity: release; twisted rubber bands: untwisting of rubber band transfers energy directly to the Rolling Racer’s body, thus turning the wheels; wound rubber band spins the axle which in turn spins the rear wheels of the vehicle.*)

EXPLORE

2. Distribute the K’NEX Education materials and have students build the spring racer shown on Pages 14-15 of the Building Instructions Booklet. Emphasize that the placement of the spring motor is critical to the correct functioning of the racer. The spring motor must be positioned with the arrow on the top and pointing forward.
3. Once built, allow the students several minutes to investigate how the model works, then ask them:
 - What is the energy source? (*The spring.*)

- How can the power of the energy source be increased?
(By pulling the car backwards on the floor or turning the wheel by hand.)
- How is the energy transferred to the vehicle?
(When the racer is moved backwards, mechanical energy is added to the system causing the wheels to turn the axle, which turns the gears visible inside the spring motor. The moving gears wind the spring inside the motor. Thus the mechanical energy is stored as potential energy in the spring. The wound up spring then transfers the energy back to the gears and the gears transfer it to the axle and the wheels when the car is released.)

Teacher's Notes

- The spring motors have a safety feature built into the design that ensures that they cannot be wound past a predetermined point. If students try to wind the motors beyond their capacity, the gears inside the motor will slip and a clicking sound will be audible. Inform students that they must stop winding the spring when the clicking sound starts.

EXPLAIN

4. Distribute copies of **Student Response Sheet 12** to students and ask them to complete Questions 1-7. Students will:
 - Design and conduct a fair test investigation to determine if increasing the energy in the spring of the racer will increase the distance the racer travels.
 - Devise a way to count the number of windings, partial windings, or winding distance. If they need help you may want to suggest they could use any of the following methods: use an identifying mark on the rear wheel, or add a small piece of tape to the tire wall and then count the number of times that identifying mark passes the K'NEX Connector holding the axle.
 - Accurately measure the distance the racer travels. Remind the students to measure the progress of the racer (start to finish) from the same spot on the racer.

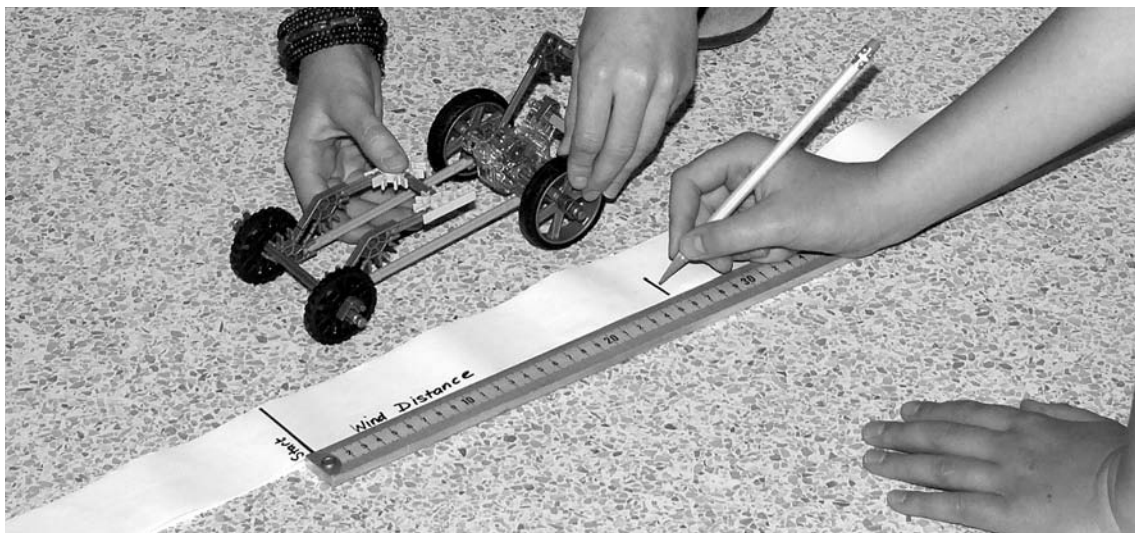

5. Ask students to complete **Student Response Sheet 12**, using the data collected.
6. Ask students to complete the Math Challenge that appears on **Student Response Sheet 12**.



ELABORATE

7. In this segment, students will be expected to compare spring racers to rubber band racers.

EVALUATE

TRACTOR PULL DESIGN BRIEF

8. The evaluation component of this investigation introduces the real-world setting of a tractor pull competition. If your students are not familiar with this type of competition you may want to provide photos or video of these events, or ask your students to use an Internet search engine to obtain more information. Students are expected to make modifications to their rubber band or spring motor racers to increase the potential energy of these vehicles.

Teacher's Notes

- *As a part of the Tractor Pull Design Brief, students are to seek teacher approval before they begin design changes. Please ensure that the changes they have proposed will not result in pulling the model apart or propelling pieces from the model. It is recommended that students wear safety goggles during their design and testing.*

EXTEND

Challenge the students to:

- Design a racer that would stop between two predetermined spots on the floor, such as 300 cm and 330 cm.
- Design a racer that would travel over a long distance, but at a very slow speed.





a



b



c

1. What is the energy source used by each vehicle?
 - a.
 - b.
 - c.
2. How can the power of each of the energy sources be increased?
 - a.
 - b.
 - c.
3. How will this increase affect each of the vehicles?
 - a.
 - b.
 - c.
4. Describe how the energy is transferred from its source to the vehicle.
 - a.
 - b.
 - c.



Student Response Sheet

12

Name: _____

Date: _____

Design and conduct a “fair test” to find out if there is a pattern between the distance needed to wind up the spring racer and the forward distance that the racer travels.

1. Describe the procedure you will follow:
2. What variables will you hold constant throughout the investigation?
3. What will be your independent variable?
4. What will be your dependent variable?
5. How will you make sure that the distance the spring racer is pulled backward (winding up the racer) is measured accurately?
6. How will you accurately measure the distance the spring racer travels forward?
7. Design a table to display your experimental data. Make sure that your table has labels that are similar to your independent and dependent variables. Remember that a minimum of three trials, and an average, is required for each set of data.



On Your Own

8. **Use your data to create your own graph.** (Remember that the independent variable is placed on the **X-axis** and the dependent variable on the **Y-axis**. Include the basic graphing essentials by providing a title for the graph, labeling the axes to match the data table, numbering the axes with a scale, plotting the data, and drawing a line of “best fit.”)

9. In your own words, describe the results of your investigation.

10. Give an example of how you could use your graph to predict the distance your racer will travel for an untested winding distance.

11. Math Challenge

- Create a formula that can be used to predict the travel distance of the spring racer if the wind-up distance is known. Write your formula in the space below and then test it. Show your results.

- Conduct an experiment that will enable you to find the spring racer’s speed for the shortest and longest wind-up distances you tested previously. Show all your work.

$$V=d/t \text{ (} V= \text{ speed, } d= \text{ distance, } t=\text{time)}$$

	Speed
Shortest Wind-up Distance	
Longest Wind-up Distance	



Student Response Sheet

12

Name: _____

Date: _____

12. In your own words explain when your spring racer had the most potential energy. What evidence do you have to support your statement?

13. If the floor surface was the same for all types of racers, attempt to answer the following:

- Compare the spring racer data with the rubber band racer data.
- Which of these energy sources do you feel is the most powerful?
- What is your evidence? Use the terms **potential energy** and **kinetic energy** in your answer.



The Context:

Significant design changes in the production of vehicles often occur because of competition.

The Scenario:

Your annual State Fair's tractor pull contest is right around the corner and you have decided to enter the competition. You are confident because you have extensive experience with potential and kinetic energy systems.

The Challenge:

The challenge for your research and design team is clear. According to the rules of the contest the vehicle that crosses the finish line in the shortest amount of time, while pulling a mass of 25 grams, will be declared the winner. It is obvious that the potential energy of your regular racers needs to be increased.

The Limitations:

- Craft an action plan before racer modifications may begin.
- The action plan must be approved before racer modifications may begin.
- You will have access to general classroom supplies and other K'NEX Education materials.

The Rules:

- The 25 gram mass is a butter tub on a string, containing 10 pennies*.
- You must show evidence that their racer modifications have made a difference in the potential energy of their racer.
- No racer modifications or repairs may occur after the testing begins.
- You must compute the speed of your racer.
- You must write a report about this competition. Reports should include a description of the modifications made to the racers to increase its potential energy, the testing that occurred, and the results of that testing. In addition, each report should include additional changes that might be made to further increase the potential energy of the racer.
- Redesign your model and repeat the steps above to determine the winning design.

Use pennies dated **after 1982 because they have a mass of 2.5 grams. Pennies with earlier dates have a mass of 3.1 grams, while pennies minted during 1982 could weigh either 3.1 grams or 2.5 grams.*

PART II - Collecting Data

Objectives

Students will be able to:

- Infer how to increase the potential energy of the Spring Racer.
- Design and conduct tests for the purposes of collecting data.
- Identify patterns in collected data and make reasonable interpretations.
- Create and present a data-supported poster that clearly communicates product assets.

Materials

- K'NEX Education Force and Newton's Laws materials
- Rolls of pennies (20 per roll)
- Masking tape
- Adding machine tape
- Metric tapes
- Stopwatch or clock with a second hand.
- Advertising Design Brief
- Paper/card for poster

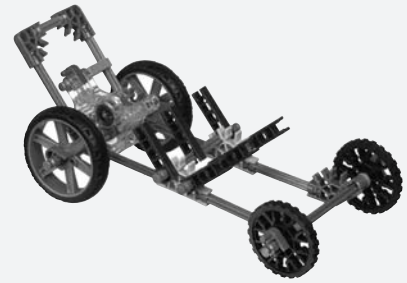

Design Brief:
2 - 3 x 45 minutes

PROCESS**ENGAGE**

1. View a selection of video clips of TV advertisements for new automobiles, or use a selection from newspapers/magazines.
2. Ask the students to describe the most common selling features that automobile manufacturers use in these ads. Field and record their responses. If vehicle speed and carrying capacity are not suggested, weave this into the discussion.

EXPLORE

3. Ask the students to explain what they did to increase the potential energy of their spring motor racers. As the students share the modifications they made to their racers, ask them to also provide evidence that these changes did make a difference. Challenge students to use the terms potential and kinetic energy in their explanations.
4. Explain that students will be given a design brief that challenges them to find the maximum speed for their spring motor racer for every possible load, up to a maximum of six loads. A roll of 20 pennies will be considered a single load.
5. Distribute copies of the **Advertising Design Brief** and ask the students to:
 - Craft a "fair test" investigation for collecting supportive data.

EXPLAIN

- Students will then:
 - Test their vehicles.
 - Compile their data.

ELABORATE

- During this phase the students will be expected to craft their advertising campaign.

EVALUATE

- Student present their advertising posters.

EXTEND

- Students can be challenged to:
 - Design and collect experimental data about how effective the spring motor racer is at moving uphill.
 - Convert the spring motor racer to a four-wheel drive vehicle.
 - Modify the racer to run in circles or manipulate the variables associated with this racer to make it stop at a specific distance from the starting line (+/- 4 cm).
- An interesting model that can be constructed from the K'NEX materials is that of the spring motor tricycle. While most of the investigations use the four-wheel spring motor racer, the tricycle could present some challenging design problems for students. Consider asking them to:
 - Re-design the tricycle so that the handlebars turn like a real bicycle or design a sidecar to accommodate a passenger.
 - Modify the tricycle to enable it to perform a "wheelie", or to travel further than the initial capacity of the spring motor.



Advertising Design Brief

The Context:

Consumers purchase many products every year. Some products perform as advertised, while others do not. As a result, savvy consumers will compare products before making a selection.

The Scenario:

Product manufacturers often turn to advertising agencies to develop campaigns that present products in a favorable way. These advertising campaigns often use performance data as one of the highlighted features. This is especially true of automobile manufacturers.

The Challenge:

Your advertising firm has been hired by the Zippy Do Automobile Company to promote this year's line of cars. In the past, the car company has purchased television and radio spots, as well as newspaper and magazine space, for their ads. Your challenge is to design a newspaper or magazine advertisement that the Zippy Do Board of Directors will approve.

The Limitations:

You will be taking on the following roles:

- * **Engineer:** Responsible for conducting all speed and load tests.
- * **Recorder:** Responsible for collecting and tabulating all experimental data.
- * **Graphic Designer:** Responsible for images, lettering, and the color selection for advertisement.
- * **The Advertising Coordinator:** Responsible for crafting the advertising campaign including such things as the product name, slogans, poems, and the general "flavor" of the sales pitch.
- * **Consumer Advocate:** Responsible for assuring product labels are accurate and complete.



The Rules:

- Your advertisement must use one or more of the following approaches: Humor, sorrow, fear, need, or personal appeal.
- Your poster-sized advertisement must include:
 - * Evidence that the advertisement is supported by test results.
 - * Data displays must be present in advertisement (charts, tables, graphs).
 - * Descriptive statements about vehicle performance. The terms **potential** and **kinetic** energy must be used in the advertisement.
 - * Advertisements should contain pictures, bright colors, and attractive lettering.
 - * The base price of vehicle must appear.
 - * The carrying capacity (maximum of 300 grams), should be included somewhere in the data.
 - * Speed data (loaded and unloaded), must stand out in some way.
 - * Dealer Information (address, phone, Internet website).

Lesson 5

RACING WITH THE WIND

Objectives

Students will be able to:

- Identify ways to increase the kinetic energy of a wind-powered vehicle.
- Design and implement a “fair test” procedure to test the impact of inferred variables.
- Create and interpret appropriate data displays.
- Apply knowledge to solve a new problem.

Materials

- K’NEX Education Force and Newton’s Laws materials
- Building Instructions Pages 6-7: Wind Racer
- File cards (3 x 4, 4 x 6, 5 x 8)
- Hole punch for preparing the file cards
- Masking tape
- Box fan/fans
- Adding machine tape
- Graph paper
- Metric tape
- Stopwatch or clock with second hand
- Copies of:
Student Response Sheet 13
‘The Wind Bag Express’
Design Brief

You will need:

- Completed model of the Wind Racer
- A box fan



Time to Build:
Less than 15 minutes

Length of Lesson:
45 - 50 minutes

Design Brief:
1 x 45 minutes

PROCESS

ENGAGE

1. Set up the Wind Racer model in front of a box fan. Ask the students to:
 - Observe the wind powered racer being pushed by a current of air from the fan.
 - Make suggestions regarding the potential and kinetic energy of the vehicle and how that energy is transferred. Field the student responses and record their ideas.
 - Discuss ways to increase the kinetic energy of the wind-powered racer and consider **how they could tell that the kinetic energy was increased.** (*Measure the speed.*)
 - Record the students’ thoughts, and query them as to their rationale.
2. Distribute copies of **Student Response Sheet 13.**

EXPLORE

3. Select one of the Wind Powered Challenge Cards, then design and carry out a “fair test” procedure for answering their chosen question.

EXPLAIN

- Students are responsible for communicating the results of their investigation through the construction of a graph and a written interpretation.

ELABORATE

- If there are questions yet unanswered allot additional time to resolve these queries.
- Once all questions have been answered it is time to share and compile the data obtained from the investigations. You may want to use a data chart, such as the one shown below, for this.



Increasing the Kinetic Energy of the Wind Powered Racer

VARIABLE INVESTIGATED	RESULTS
Size of card	
Type of sail material	
Etc.	
↓	

EVALUATE

- The evaluation phase of this lesson focuses on a design brief.
 - In an attempt to produce the most efficient model, **'The Wind Bag Express' Design Brief** challenges students to employ two, or more, of the variables that have been proven to increase the kinetic energy of the wind-powdered racer.
 - Remind students of the design loop as this is an open-ended challenge and lends itself to multiple modifications of the designed model.

EXTEND

8. The wind powered racer lesson could be extended by asking the students to:
- Create a wind-powered racer that is able to move in the slightest breeze.
 - Investigate the efficiency of hard plastic sails*.
 - Modify the wind-powered racer to work in a cross wind.

Teacher's Notes

**These sails can be crafted easily from two-liter beverage containers:*

- *Cut off the top and bottom of the bottle leaving a plastic cylinder. The cylinder can then be cut in half lengthwise creating two curved sails.*
- *Have the students experiment with other shapes and sizes of these bottle sails.*
- *Keep safety in mind and provide safety glasses for students. It is strongly recommended that the teacher use a knife to create a slit in the top and bottom sections of the bottle as a "starter" so that the students do not have to force their scissors through the plastic.*



1. Select one of the following challenge cards.
2. Design a “fair test” investigation to answer the selected question.

Note: You also have the option of creating a question.

Wind-Powered Challenge Cards

Does the size of the sail (3x5, 4x6, and 5x8) increase or decrease the kinetic energy of the wind racer?	Does the shape of the sail make a difference in the kinetic energy of the wind racer? <i>Note: To be a fair test, the area of each shape must be the same.</i>
Does the speed of the fan make a difference in the kinetic energy of the wind racer?	Does the orientation of the sail, vertical or horizontal, make a difference in the wind racer’s kinetic energy?
Does its placement in front of the fan make a difference in the racer’s kinetic energy?	Will the speed of the fan change the kinetic energy of the wind racer?
Will the type of sail material, such as cloth, paper, or plastic, make a difference in the kinetic energy of the wind racer?	Will a curved or folded sail increase the kinetic energy of the wind racer?



Student Response Sheet

13

Name: _____

Date: _____

EXPLORE

3. Write out your “fair test” plan of action using the outline below. Be sure to use complete sentences in your answers so that this outline can be used as your lab report.
 - a. Which question will you investigate?

 - b. What materials will you need to answer this question?

 - c. Which variables do you think should be held constant?

 - d. Which variable will you make your independent variable? Which will be your dependent variable?

 - e. What kind of information (data) will you collect? How will you know that the kinetic energy of the racer has changed?

 - f. How many trials will you conduct?

 - g. How will you display this data? Show your display here.



EXPLAIN

On Your Own

4. Use your data to construct a graph.

5. Describe the results of your investigation:

ELABORATE

6. What other changes can you suggest that might increase the kinetic energy of your wind-powered racer?



'The Wind Bag Express' Design Brief

The Context:

Each time oil prices increase, inexpensive and alternative sources of energy attract more attention.

The Scenario:

The popularity of hybrid cars and alternative fuels is helping our country become less dependent on oil as an energy source. Wind energy is also growing in popularity as a way to generate electricity. Could the power of the wind be harnessed to help power our cars as well?

The Challenge:

There are places in our country where the wind blows much of the time and your research company, 'Geeks Galore,' has decided that a car with wind-powered capabilities would be a viable project to investigate. Prior tests with wind-powered models have confirmed that certain variables can increase the kinetic energy of such a car. Your challenge is to apply this previous research to create the fastest wind powered vehicle possible.

The Limitations:

- Design and create an action plan.
- Construct, test, and refine the wind racer design.
- You may use any materials to construct their vehicle.
- Vehicles must stay inside the track (two strips of adding machine tape 60 cm apart).
- You will be responsible for computing and averaging the speed of all the time trails.

The Rules:

- Keep a 'Wind Bag Express' Journal. All design changes, sketches, test results, data, conclusions, and ideas for further modifications should be recorded.
- There are no weight requirements for the vehicle.
- You will be responsible for supplying additional materials.
- Should the vehicle stray off the track, a 1-second penalty will be added to the total vehicle travel time.

MOTORIZED RACERS

Lesson 6

Objectives

Students will be able to:

- Correctly use the formula $v = d/t$ to compute speed.
- Manipulate the formula to find speed, distance, or time.
- Design appropriate data displays.
- Use information to expand understanding and build skills.
- Correctly identify the energy source and energy transfer system in a mechanical device.

Materials

- K'NEX Education Force and Newton's Laws materials
- Building Instructions Booklet Pages 20-23: Battery Powered Racer - Direct Drive
- Stopwatch or clock with second hand
- Student Response Sheets 14 and 15
- Use of a large area such as a lunchroom or gymnasium
- Ramps used in Lesson 1

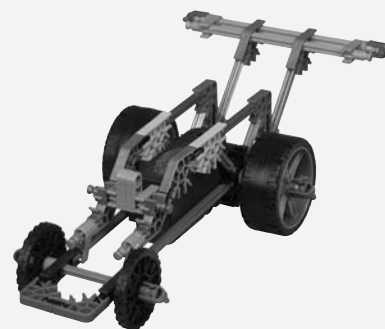

Time to Build:
15 - 20 minutes

Length of Lesson:
45 minutes

Teacher's Notes

- *The activities in this lesson make use of three electric motor powered racers (pages 20-23 in the Instructions Booklet). While the basic structure of each vehicle is the same, small design modifications allow each to move at a different speed. One version operates with a direct drive system, another is geared up with a ratio of 2.4:1, while the third is geared down with a ratio of 2.4:1.*
- *It is suggested that a direct drive model be built and tested (see lesson) to establish base line data. Once this has been established and recorded, the geared up and the geared down models can be constructed and comparative data can then be collected.*
- *The focus of this lesson is not on the design and implementation of a "fair test" investigation, but rather on the precise collection of data and, in turn, the use of this data to make accurate predictions.*

PROCESS

ENGAGE

1. Ask the students to review their previous investigations to identify which racer traveled the greatest distance. Answers may vary depending on the racer and procedure followed.
2. Tell the students that they now have the opportunity to build another kind of racer that will out-distance anything they have built to this point.

EXPLORE

3. Building and testing the models.
 - Distribute the K'NEX Building Instructions Booklets (Pages 20-23) and **Student Response Sheet 14**.
 - Construct a **direct drive** motorized racers.
 - After the racers are completed ask the students to determine how fast they move.

EXPLAIN

4. Collecting and using the data.
 - Students should follow the guidelines in **Student Response Sheet 14** to:
 - * Design a data table.
 - * Collect data that could be used to compute the speed of the motorized racer.
 - * Compute the average speed of the racer.

ELABORATE

5. Building and testing the geared up and geared down models of the motorized racer.
 - Distribute **Student Response Sheet 15**. Provide time for students to build and test the different versions of the racer. This will involve students:
 - * Collecting accurate data that can be used to make predictions.
 - * Preparing a comparative analysis of all the racers.

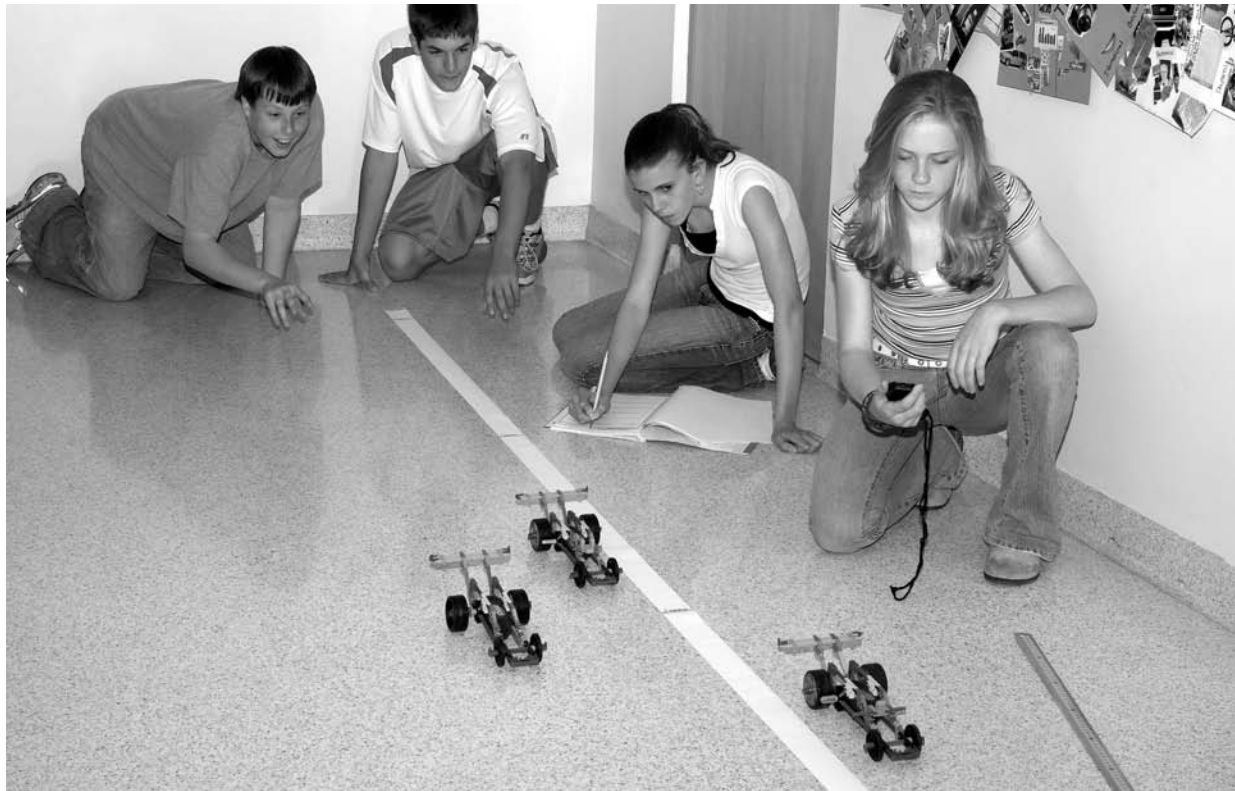

6. Determining the gear ratios.

- If your students have had experience with computing gear ratios ask them to determine the gear ratio of the geared racers. You may want to remind them that gear ratio refers to the relative sizes of the driver and driven gears.
- If the students have not had this experience then you may want to demonstrate how this ratio is determined by counting and comparing the number of teeth on each gear:

$$\text{Gear Ratio} = \frac{\text{Number of teeth on the large gear}}{\text{Number of teeth on the small gear}}$$

When a large gear drives a small gear, the system is geared up by the computed ratio. When a small gear drives a large gear, the system is geared down by the computed ratio.

7. Computing the speed of the geared up and geared down racers.

- After students have tested and collected data regarding the speed of the direct drive racer, they could use the gear ratio to compute the speed of the geared up and geared down racers.
- Multiply the speed of the direct drive racer by 2.4 to find the speed of the geared up racer.
- Divide the speed of the direct drive racer by 2.4 to find the geared down speed.
- This data could be added to a data chart and confirmed through actual testing.

EVALUATE

8. Once the students have tested and collected data for each of the racer models, they should be ready to interpret and apply this data to predict the outcome of a variety of test situations.

EXTEND

9. Students could be asked to:
 - Redesign the motorized racer to perform another function.
 - Make changes in the racer design so that the geared down version will be as fast at the direct drive.



Student Response Sheet

14

Name: _____

Date: _____

EXPLORE

Determine how fast the racer can travel.

- Before you begin, write out an action plan that shows how you intend to determine the **average speed** of the racer.
- Include all the materials you will need to answer this question.
- Make at least three trials and show all mathematical calculations.

OBSERVATIONS

Create a data table here to display your information:





EXPLAIN

1. What was the average speed for your motorized K'NEX racer?
2. Compare this to the other motorized racers. Was there a great deal of difference between the speeds of racers?
3. Why do you think this was so? Explain your answer.
4. What is the energy source for this racer?
5. Describe the energy transfers that are present in your racer.
6. If the motorized racer was a real car, what would be the advantage of you knowing its average speed?
7. How long would it take your motorized racer to travel a distance of 15 meters? (Show your mathematical calculations.)



ELABORATE

The plans on Page 23 of the Building Instructions booklet show versions of the racer that use gears.

1. What do you think the gears will do in these models?
2. Explain your thought process as you answered Question # 1 above.
3. You will be responsible to:
 - Collect data about the speed of the two versions of the geared racers.
 - Compare this information with the data you collected about the direct drive racer you tested the first time. (You will have to disassemble the direct drive racer to build one of the gear driven racers.)
 - Make a new data table to include the data from the direct drive racer and the two versions of the geared racers you are about to test.

OBSERVATIONS

Create a data table here to display your information:

4. Which racer is the fastest? Which is the slowest?
5. How much faster is the fastest racer when compared to the slowest racer? Show how you solved this problem.



6. The ratio of the geared up racer is 2.4:1. That means that the gear on the axle will turn 2.4 times for each turn of the gear on the motor (the driver gear).
- Multiplying the speed of the direct drive racer by 2.4 will result in the speed of the **geared up** racer. This is considered the “**ideal**” speed.
 - Dividing the speed of the direct drive racer by 2.4 will result in the “**ideal**” speed of the **geared down** racer.
 - Compute these ideal speeds and compare them to the “**actual**” speeds you found through your investigations.
-
- Why do you think the “**ideal**” and the “**actual**” speeds differ?

EVALUATE

You know the speed of each of the motorized racers. Use this information to investigate the following:

1. Go to the gym and measure the distance in centimeters from the end line to the half court line.
 - Predict how long each of the three motorized racers will take to make this journey.
 - Test these predictions and show your data and results in table form. Indicate your prediction for each racer and the experimental results for each racer. Include the difference between the predicted time and the experimental time for each racer in seconds, with a plus sign or a minus sign.

PREDICTIONS/OBSERVATIONS



2. In the gym or a hallway mark out a track at least 10 meters long and then:
- Using the speed data for your three racers, and the formula for finding speed, figure out the spot on the track where each racer will be after 30 seconds.
 - Describe how you figured this out.
 - Test the racers and present your results in written format. Include the difference between 10 meters and the distance each racer actually traveled in centimeters with a plus sign or a minus sign.

3. Use the ramps to create a “mountain course” for the motorized racers and then:
- Compute the time it will take for each of the racers to complete the course.
 - Show your data in chart form.

Caution: The motorized racer bodies do not have a great deal of clearance from the surface they travel along. Ensure that your racer will not hang up (stall) at the top of the ramp systems you design.

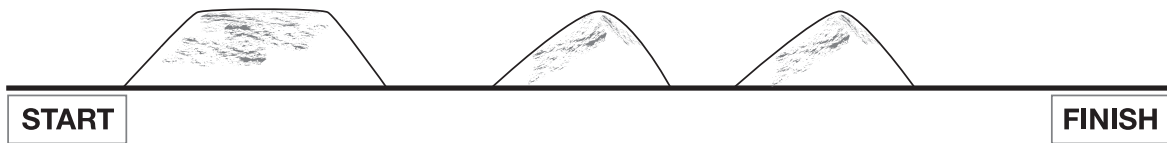



4. Select one of the motorized racers and then:
 - Design modifications that will increase its speed.
 - Conduct at least three trials.
 - Chart your data.
 - Write a brief report about the results.

5. You know that each of your motorized racers travels at a different speed. Does this also mean that each racer will be able to drag a different amount of weight? Design and conduct an investigation to answer this question.

6. The ability to get from one place to another in the **shortest** time possible is a reason for using a **fast** vehicle. But what is a reason for using a **slow** moving vehicle? Use the results from #5 above to support your answer.

Objectives

Students will be able to:

- Identify ways to increase the potential energy of the flywheel racer.
- Compare the efficiency of different energy sources and energy transfer systems.
- Modify an existing system to improve its performance.
- Communicate findings in a variety of ways.

Materials

- K'NEX Education Force and Newton's Laws materials
- Building Instructions Booklet Pages 18-19: Pull String Flywheel Racer
- Additional K'NEX pieces for vehicle modification
- Student Response Sheet 16
- Stopwatch or clock with second hand



Time to Build:
15 minutes

Length of Lesson:
2 x 45 minutes

Teacher's Notes

A flywheel is a device that can be used to mechanically store energy in the form of kinetic energy. A weighted wheel is sent into motion by some means and the moving inertia of the spinning wheel stores the energy.

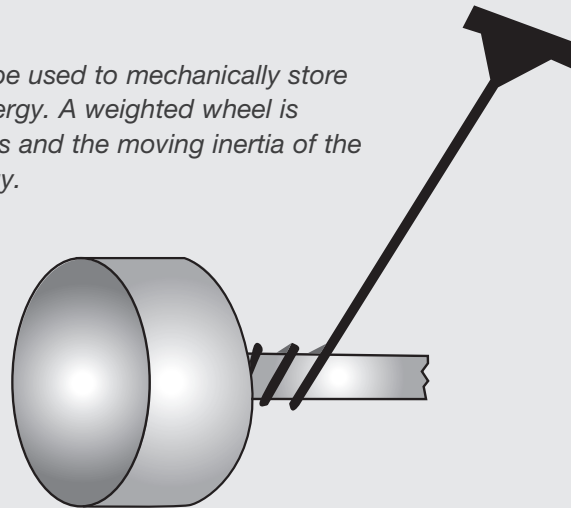

Fig. 1: When a large force is applied to the handle, the cord spins the axle causing the heavy wheel to turn at a high rate of speed. The heavy, spinning wheel has a great deal of kinetic energy that can be used to power a system. In the case of the K'NEX Education Pull String Flywheel Racer, once the spinning flywheel touches the floor, its kinetic energy powers the model.

You may want to refer your students to the following web sites for additional information.

<http://en.wikipedia.org/wiki/Flywheel>

http://en.wikipedia.org/wiki/Potter's_wheel

PROCESS

ENGAGE

1. Ask the students to list all the forms of energy they have used. (*Gravity, stretching and twisting rubber bands, compressing springs, and chemical and electrical energy in the form of batteries.*)
2. Explain that they will be building and investigating yet another energy transfer system, the flywheel.
3. Demonstrate how the flywheel system works and allow the students to explore this system before they incorporate it into a racer. Ask the students if they have ever seen an energy transfer system like this. (*Pull-start device used on a variety of lawn and garden equipment, as well as on some versions of a potter's wheel.*)

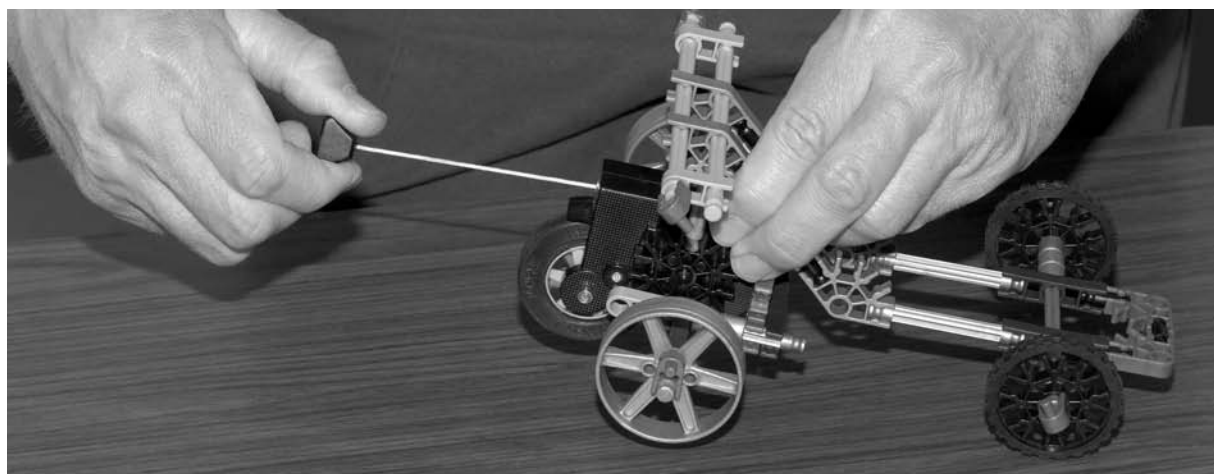

EXPLORE

4. Ask the students to use their K'NEX materials and Instruction Booklet to construct the flywheel racer.
5. Once the racers are completed give the students a reasonable amount of time to explore this new racer.
6. Have the students use **Student Response Sheet 16** to record their responses and plans.

EXPLAIN

7. Ask the students to evaluate the flywheel system in comparison to other racer systems.

ELABORATE

8. By the way of an extension, students should:

- Modify the flywheel racers to convert them into front wheel drive vehicles.
- Collect data regarding their modification.

EVALUATE

9. Student should craft a persuasive letter extolling the virtues of the vehicle modifications.



EXPLORE

1. Explore the flywheel racer.
 - Find out how to increase the potential energy of the system.
 - Describe how you accomplished this.

EXPLAIN

2. The energy transfer system of the flywheel racer is different from the other racers you have used.
 - Do you think this system is more effective, less effective, or the same as the other racers?

 - What evidence (data) do you have to support your answer?

ELABORATE

3. In real automobiles the drive train is either front wheel drive or rear wheel drive. The flywheel racer is an example of a rear wheel drive system.
 - Redesign and rebuild your flywheel racer to be a front wheel drive system.
 - Once you have completed this modification test the racer and compare the data to that of the original design.
 - Include a drawing or digital picture of your newly designed racer as a part of your write-up.



Student Response Sheet

16

Name: _____

Date: _____

EVALUATE

4. Write a persuasive letter to the Flywheel Automotive Company explaining your modification and why they should consider this change for their new models. Use experimental data (charts, graphs, and/or results) to support your position.

FLYWHEEL RACER

