

Explorations in Math, Science and Literacy

Teacher's Guide

KNX 96490-V2
© 2009 K'NEX Limited Partnership
Group and its licensors.

K'NEX Limited Partnership Group
P.O. Box 700
Hatfield, PA 19440-0700

Conforms to ASTM Standard Consumer
Safety Specification on Toy Safety, F963-07.
5,199,919; 5,346,420; 5,350,331.
Other U.S. and foreign patents pending.

K'NEX and K'NEX Education are registered
trademarks of K'NEX Limited Partnership
Group.
Protected by International Copyright.
All rights reserved.
Printed in the United States of America.

Visit our website at
www.knexeducation.com
Email: abcknex@knex.com
Phone: 1-888-ABC-KNEX (Toll Free)



WARNING:

CHOKING HAZARD - Small parts.
Not for children under 3 years.



AVERTISSEMENT:

DANGER D'ÉTOUFFEMENT - Pièces de petite taille.
Ne pas donner aux enfants de moins de 3 ans.



Author:

Kerry Landon

- Elementary Teacher and Mathematics Coordinator – Dallas School District in Dallas, PA
- Presidential Award for Excellence in Mathematics Teaching – 2004
- Outstanding Young Educator Award – PASCD – 2006
- Adjunct Instructor -Graduate Teacher Education Program – Wilkes University, Wilkes-Barre, PA

Acknowledgements:

Excerpts from the Science Content Standards:

Reprinted with permission from **National Science Education Standards**, ©1996 by the National Academy of Sciences, courtesy of the National Academies Press, Washington, DC.

Excerpts from the Mathematics Standards and Expectations:
Reprinted with permission from **Principals and Standards for School Mathematics**, © 2000 by the National Council of Teachers of Mathematics, courtesy of the National Council of Teachers of Mathematics.

Excerpts from the National Geography Standards: Reprinted with permission from the Geography Education Standards Project, 1994 **Geography for Life: The National Geography Standards**. Washington, D.C.: National Geographic Society Committee on Research and Exploration, courtesy of the National Geographic Society.

A Note About Safety

Safety is of primary concern in science and technology classrooms. It is recommended that you develop a set of rules that governs the safe, proper use of K'NEX in your classroom. Safety, as it relates to the use of the Rubber Bands should be specifically addressed.

PARTICULAR CAUTIONS:

Students should not overstretch or overwind their Rubber Bands. Overstretching and overwinding

can cause the Rubber Band to snap and cause personal injury. Any wear and tear or deterioration of Rubber Bands should be reported immediately to the teacher. Teachers and students should inspect Rubber Bands for deterioration before each experiment.

Caution students to keep hands, face, hair and clothing away from all moving parts. Never put fingers in moving Gears or other moving parts.



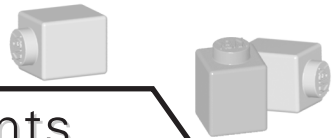

Table of Contents

		PAGE #
INTRODUCTION		2
TEACHER NOTES		3
LESSONS	GRADE LEVEL	
Lesson 1: Digital Art I	1	4
Lesson 2: Digital Art II	1	5
Lesson 3: Digital Art III	1-2	6
Lesson 4: Paint By Number I	1-2	7-8
Lesson 5: Paint By Number II	1-2	9-10
Lesson 6: Coordinate Creations	3	11-12
Lesson 7: Letters I	1	13
Lesson 8: Letters II	1	14-15
Lesson 9: Letters III	1-2	16-17
Lesson 10: Build and Spell	1	18-19
Lesson 11: Organisms	2-3	20-21
Lesson 12: Environments	2-3	22-23
Lesson 13: Data Collection and Graphing	1-2	24-25
Lesson 14: Actual Factual Graphing	2	26-27
Lesson 15: Number Building	1	28-29
Lesson 16: Place Value	1-2	30-31
Lesson 17: Number Riddles	1-2	32-33
Lesson 18: Number Sentences	2	34-35
Lesson 19: How Much Is It Worth?	3	36-37
Lesson 20: Polygons I	3	38-39
Lesson 21: Polygons II	3	40-41
Lesson 22: Dividing Lines and Symmetry	1-3	42-43
Lesson 23: Perimeter I	2	44-45
Lesson 24: Perimeter II	2	46-47
Lesson 25: Perimeter III	2	48-49
Lesson 26: Perimeter and Area	2-3	50-51
Lesson 27: Picture Perfect Coordinate Graphing	3	52-53
Lesson 28: Treasure Map I	1	54-55
Lesson 29: Treasure Map II	1-2	56-57
Lesson 30: Treasure Map III	2-3	58-59





Introduction

According to Moch (2001), if asked, most teachers would agree that to increase students' learning a teacher needs to increase the amount of active involvement happening within the classroom. Utilizing manipulatives is an effective approach to increase the involvement of the students and thus, increase learning. "Manipulatives can be important tools in helping students to think and reason in more meaningful ways. By giving students concrete ways to compare and operate on quantities, such manipulatives as pattern blocks, tiles, and cubes can contribute to the development of well grounded, interconnected understandings of mathematical ideas." The use of manipulatives in the classroom is necessary; it offers a natural way for children to make sense of what they are trying to learn (Moch, 2001).

This teacher's guide has been developed to assist teachers as they challenge students to explore, investigate, exercise, develop and present mathematical skills and concepts as well as literacy skills, science content and process skills, and social studies skills. This resource is designed to actively engage students with math, science, reading, social studies and art concepts. Each activity will identify student objectives, national standards where appropriate, materials necessary to accomplish the task, step-by-step procedures to implement the lesson and strategies to evaluate student comprehension of the concept(s) and skill(s) being presented.

The activities have been developed to be completed in 30 – 45 minute time periods. All of the activities can be presented as stand alone lessons, but many of them build off of each other in a sequential fashion to provide students with an in-depth knowledge of concepts and many opportunities to practice and refine what they have learned.

The students may work independently on each activity or may be placed into partnerships/small groups to work cooperatively. Each Explorations in Math, Science and Literacy Set comes with eight (8) transparent panels, K'NEX bricks, and eight (8) pages of templates for student use.

It is recommended that educators read through the state and local standards that pertain to their students and then determine which of the following activities will best match their curriculum goals and objectives as well as the needs of the students. Suggested grade level applications for the various activities are listed in the Table of Contents. Please review the lessons for all of the grade levels as you may discover ideas that will work for your students with some adaptations of the original activity.

Cain-Caston (1996) and Heuser (2000) believed that using manipulatives with efficiency and expertise takes time and practice. Teachers must gain proficiency in using these devices. The benefits for appropriate usage outweigh the beginning challenges and are well worth achieving to employ these dynamic tools properly. In the spirit of the statement above, it is suggested that the teacher experiment with the materials and the various activities outlined in the Teacher's Guide.

References

Cain-Caston, M. (1996). Manipulative Queen. *Journal of Instructional Psychology*, 23(4). p. 270-74.

Heuser, D. (2000). Mathematics class becomes learner centered. *Teaching Children Mathematics*, 6(5). p. 288-95.

Moch, P. (2001). Manipulatives work!. *The Educational Forum*, Retrieved July 3, 2008, from http://findarticles.com/p/articles/mi_qa4013/is_200110/ai_n8975782?tag=artBody:col1



Teacher Notes:

Your new K'NEX Education Explorations in Math, Science and Literacy Set includes the following components

- 160 Black K'NEX bricks
- 42 Blue K'NEX bricks
- 172 Red K'NEX bricks
- 162 White K'NEX bricks
- 112 Yellow K'NEX bricks
- 448 Green K'NEX bricks
- 130 Orange K'NEX bricks
- 8 Transparent brick Panels
- 8 8 ½" X 11" Template Cards
- 1 CD – Teacher Guide and Templates
- 1 Storage Tray with dividers and a snap-on lid

- Your set includes eight cards of templates that will be used as students complete the various activities outlined in the Teacher's Guide.
- Cut along the dotted lines to separate your templates.
 - Templates T – 1 to T – 8 will be used directly by the students.
 - Templates T – 9 to T – 24 will serve as copy masters that you can use to make multiple copies for student use.
- The numbers on the templates are used in the Teacher's Guide to identify which templates are needed for specific activities.
- Each activity found in the Teacher's Guide includes an image of the template(s) used in that activity. This provides you a reminder as to the templates you must copy for the students to use during the activity.
- Some templates are in color while others are black and white. There are sufficient copies of the full color templates for students to complete all activities as outlined in the Teacher's Guide that require color templates.
- You can make as many copies of the templates as is required for the various activities you complete with your students.
- You may wish to make copy masters for your own use that include for example, 2 copies of template T-23 on a single sheet of paper to reduce your paper usage.
- Keep a master set of templates to ensure that you have them available this year and for years to come.
- The CD that accompanies your set contains a folder that includes copies of all of the templates. Additionally, the CD includes files of templates for 24 additional letters of the alphabet and 8 additional numbers in electronic form.
- Students should use green K'NEX bricks for all activities related to the formation of letters and/or numbers.
- The storage tray that came with your set is an excellent place to safely store the bricks and panels that make up this fine educational set.
- During time periods when your students are using their materials daily, you may wish to use eight plastic bags that can be snapped shut. Store one panel and a collection of green bricks in each of the bags. This will decrease the students' need to visit the storage tray for additional bricks during class activities.

Lesson 1

DIGITAL ART, PART I

Lesson Topic: Visual Arts -
Creating Pictures From a Pattern

Grade: 1 **Lesson Length:** 30-45 minutes

Student Objectives

Students will:

- follow a pattern to create an image
- build an image of a car, cow, rooster, or flower using manipulatives
- follow a pattern to correctly position colored bricks on a plastic panel
- identify the image produced

Grouping for Instruction

- Whole group for introduction, instruction and closure
- Individual or partners for activity

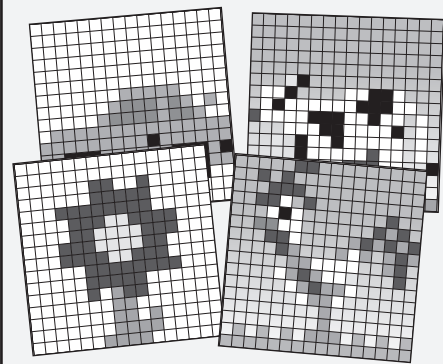

Materials and Equipment

- Eight panels
 - K'NEX Bricks
 - Eight copies of templates
 - Full-color templates (2 of each image)
- T-1: Car T-2: Cow
T-3: Flower T-4: Rooster

PROCEDURE

- Divide the class into partners, small groups, or allow students to work independently.
- Distribute panels and a small handful of K'NEX bricks to the students. Place the red tray with the remaining bricks in a central location where students can easily gather additional bricks as they are needed.
- Demonstrate how to properly place K'NEX bricks on the panel and review how to remove those bricks from the panel.
- Allow students to practice placing bricks on the panel and removing them as you move about the room making observations of their successes.
- Distribute the full-color templates.
- Instruct students to place their panel on top of the colored template.
- Have the students use the template to direct their placement of bricks on the panel as they recreate the image on the template. They will cover all green squares on the template with green bricks, all red squares with red bricks, etc.
- Have each group show their image to the class and describe the image.

SUMMARY AND CLOSURE

- Ask students to talk with a partner and write down what they did today in class.
- Ask students to talk with that same partner and to write down what they learned today in class.
- Ask several students to share their responses.

ASSESSMENT

- Observe the students during the activity to make sure they are using the manipulatives correctly. Provide assistance as necessary.
- Observe and note strategies that students use to check for errors and correct their images.
- Have the students switch templates to produce a different image.

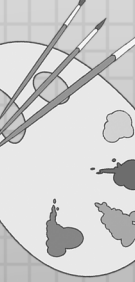

Lesson Topic: Visual Arts - Creating Original Images Using Colored Bricks

Grade: 2 **Lesson Length:** 30-45 minutes

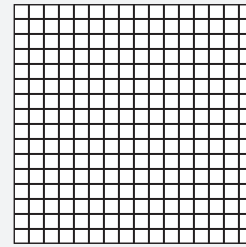

Student Objectives

Students will:

- build an image on a panel using bricks
- transfer that image to a paper grid in color
- identify the images they have produced and created

Grouping for Instruction

- Whole class for introduction, instruction, and closure
- Individually or small groups for the activity.

Materials and Equipment

- Eight panels
- K'NEX Bricks
(You may wish to presort the bricks and make eight sets of identical brick collections.)
- Eight or More Copies of Grid: T-23
- Crayons or markers

PROCEDURE

- Demonstrate how to properly place bricks on the panel.
- Divide the class into partners or allow students to work independently.
- Distribute all necessary materials to students.
- Have students create a unique image using their supply of bricks.
- Instruct students to transfer their image to a paper grid using crayons or markers so that the colors used in the image are reflected on the paper template in the correct locations.
- Have each group show their image to the class and describe the image.
- Collect the papers for use in the Digital Art 3 activity.

SUMMARY AND CLOSURE

- Ask students to talk with a partner and write down what they did today in class.
- Ask students to talk with that same partner and to write down what they learned today in class.
- Ask several students to share their responses
- Explore students' understanding.

ASSESSMENT

- Observe the students during the activity.
- Use anecdotal note cards and/or check lists to record your observations.
- Compare panel images to student prepared, paper templates for correct placement of colored squares.
- Make images of your own design and prepare templates for those images in color for use by students in a performance assessment activity to determine their ability to properly place bricks on their panel according to the template provided.

Lesson Topic: Visual Arts - Build A Model From A Template Made by a Classmate

Grade: 1-2 **Lesson Length:** 30 minutes

Student Objectives

Students will:

- trade the templates they made on paper grids during the Digital Art 2 activity with a classmate.
- build a model from the template using K'NEX bricks.
- work with their classmate to verify the correctness of an image.
- identify the image produced.

Grouping for Instruction

- Whole class for introduction, instruction, and closure
- Individually for activity

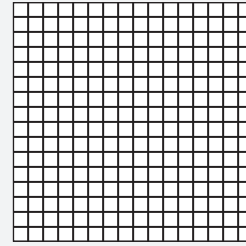

Materials and Equipment

- Eight panels
- K'NEX Bricks
- Classmates' T – 23 templates from the Digital Art 2 activity

PROCEDURE

- Demonstrate how to properly place bricks on the panel.
- Divide the class into partners or allow students to work independently.
- Distribute all necessary materials to students.
- Provide each student or group with a copy of one of their classmates' templates from the previous activity.
- Instruct students to build an image from their classmate's template.
- Have the students who created the template check the completed model for accuracy. Both parties should work together to make any corrections that are required to the image on the panel.

SUMMARY AND CLOSURE

- Ask students to talk with a partner and write down what they did today in class.
- Ask students to talk with that same partner and to write down what they learned today in class.
- Ask several students to share their responses with the class or with partners.
- Use probing questions to explore strategies students used to complete the activity.

ASSESSMENT

- Observe the students during the activity.
- Use anecdotal note cards and/or check lists to record your observations.
- Compare completed brick images to the templates provided. Evaluate the students' attention to detail and the template.
- Encourage students to prepare other templates that they can use to challenge their classmates.



Lesson Topic: Visual Arts and Mathematics - Building Images With Number Cues

Grade: 1-2 **Lesson Length:** 30-45 minutes

Student Objectives

Students will:

- follow a pattern to create an image.
- create a model to match a template.
- correctly position colored bricks on a plane.
- build an image of a boat, fish, boy, or girl from manipulatives.
- identify and describe the image produced.

Grouping for Instruction

- Whole class for introduction, instruction, and closure
- Individually for activity

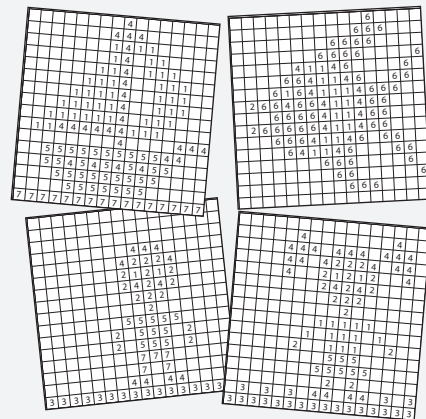

Materials and Equipment

- Eight panels
- K'NEX Bricks
- Eight copies of Paint By Numbers templates
 - Paint By Numbers templates (2 of each pattern)
 - T-5: Ship T-6: Fish
 - T-7: Boy T-8: Girl

NCTM Standards and Expectations Addressed

- Understand patterns, relations, and functions
 - sort, classify, and order objects by size, number, and other properties.

(Principals and standards for School Mathematics, Copyright 2000 by the National Council of Teachers of Mathematics.) Standards are listed with permission of the National Council of Teachers of Mathematics (NCTM). NCTM does not endorse the content or validity of these alignments.

PROCEDURE

- Demonstrate how to properly place bricks on the panels.
- Divide the class into partners or allow students to work independently.
- Distribute all necessary materials, including templates, to students.
- Instruct students to place the panel on top of their numbered template.
- Draw students' attention to the key that is included on each template.
- Ask students to hold up the brick they would use to match a '3' on their template (green). To match a '6' on their template (orange). When students successfully complete this task, they are ready to continue.
- Have students create images by placing the appropriate colored bricks on their panels above the numbers on the templates.
- Have each group show its image to the class as they identify and describe the image.

The teacher should do this activity over the course of several days to allow students to make more than one of the models.

SUMMARY AND CLOSURE

- Ask students to talk with a partner and write down what they did today in class.
- Ask students to talk with that same partner and to write down what they learned today in class.
- Ask several students to share their responses and facilitate a discussion with the entire class.

ASSESSMENT

- Observe the students during the activity.
- Evaluate the successful images produced with colored bricks.
- Use anecdotal note cards or check lists to record your observations.
- Compare student images to the template to determine whether or not the bricks are placed correctly.
- Use two of the four templates for practice activities and use the final two images for assessment purposes.

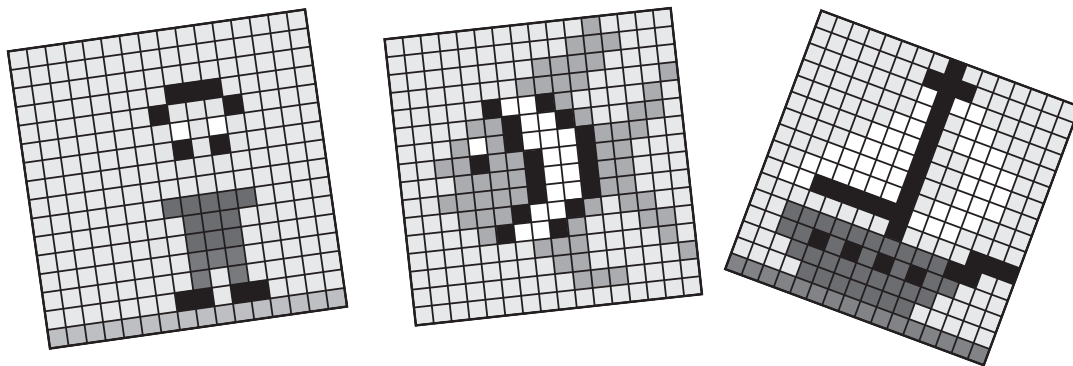

Lesson Topic: Create Your Own Paint By Number Template

Grade: 1-3 **Lesson Length:** 45 minutes

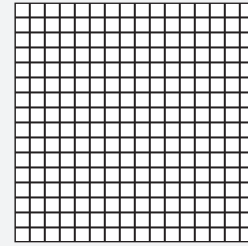

Student Objectives

Students will:

- create an image of their own design on a panel using bricks
- prepare a color vs. number chart for their image
- transfer the number cues for their image to a paper grid (T-23) by using the corresponding numbers for the various colors
- trade paper grids with a classmate and create the classmate's image

Grouping for Instruction

- Whole class for introduction, instruction, and closure
- Individually for activity

Materials and Equipment

- Eight panels
- K'NEX Bricks
Limit each student or group to;
Black-20 Blue-5
Red-21 White-20
Yellow-14 Green-55
Orange-15
- Eight copies of template T-23
- Pencils

NCTM Standards and Expectations Addressed

- Understand patterns, relations and functions
 - sort, classify, and order objects by size, number, and other properties.
- Formulate questions that can be addressed with data and collect, organize, and display relevant data to answer them.
 - represent data using concrete objects, pictures, and graphs
- Specify locations and describe spatial relationships using coordinate geometry and other representational systems

Standards are listed with permission of the National Council of Teachers of Mathematics (NCTM). NCTM does not endorse the content or validity of these alignments.

PROCEDURE

- Divide the class into partners or allow students to work independently.
- Distribute all necessary materials to students.
- Have students imagine and create an image of their own design with bricks.
- Prepare a color vs. number chart for their image. (i.e., 1 = Blue, 2 = Red, etc.)
- Instruct students to transfer their pattern to a paper grid using numbers in the squares on the T-23 template.
- Trade papers with a classmate/group.
- Have students build the image according to the numbers shown on their classmate's grid. Students must follow the color vs. number chart provided.
- Have the students who created the template check the completed model for accuracy.
- Instruct students to settle any discrepancies they discover as they complete their classmate's image.

The teacher should do this activity over the course of several days to allow students to make more than one of the models and to have multiple opportunities to design images of their own.

SUMMARY AND CLOSURE

- Ask students to talk with a partner and write down what they did today in class.
- Ask students to talk with that same partner and to write down what they learned today in class.
- Ask several students to share their responses.

ASSESSMENT

- Observe the students during the activity.
- Use anecdotal note cards and/or check lists to record your observations.
- Collect and evaluate student prepared templates and color vs. number charts.
- Challenge some students who are very successful with the design of images to design an image that spans two or four panels. This would be an excellent challenge for an Explorations in Math, Science and Literacy center in the classroom.

Lesson Topic:
Math - Alphanumeric Grid Systems

Grade: 3 **Lesson Length:** 30 minutes

Student Objectives

Students will:

- read and interpret ordered pairs
- use data to construct an image on a coordinate plane
- identify the image produced

Grouping for Instruction

- Whole class for introduction, instruction and closure.
- Eight students may work independently or eight groups may work cooperatively to complete this activity.

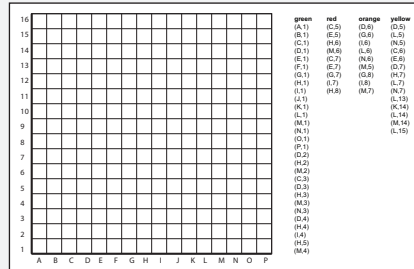

Materials and Equipment

- Eight panels
- K'NEX Bricks
- Eight copies of template T-24
- Multiple copies of template T-24 with the ordered pair data removed for assessment purposes
- Sheets of paper

NCTM Standards and Expectations Addressed

- Formulate questions that can be addressed with data and collect, organize and display relevant data to answer them
 - represent data using tables and graphs such as line plots, bar graphs, and line graphs.

Standards are listed with permission of the National Council of Teachers of Mathematics (NCTM). NCTM does not endorse the content or validity of these alignments.

PROCEDURE

- Distribute all necessary materials to students.
- Have students place their panel on top of template T-24.
- Provide students guided practice by placing examples of alphanumeric ordered pairs on the board/chart paper and asking students to demonstrate their ability to read the ordered pairs and place a brick on their panel at the correct location indicated by the data. Repeat several times with various ordered pairs.
- Instruct students to hold up their panels to show that they have correctly placed the bricks.
- Next to template T-24 there is a listing of ordered pairs in various color columns. Instruct students to place a Green brick at each location indicated by the ordered pairs in the column entitled 'Green.' Repeat the instructions for the 'Red,' 'Orange,' and 'Yellow' columns using the appropriate color bricks. This will enable students to construct an image that should be readily identifiable.
- Have students (groups) compare their results and identify any differences that they observe between their completed panel and their neighbor's. If differences are discovered, they should review the placement of bricks to make corrections.

SUMMARY AND CLOSURE

- Ask students to write three things that they learned today.
- Have them share their statements with another student or students.
- Have students share with the class.

ASSESSMENT

- Students (groups) will make a picture of their own design using available bricks and their panel.
- Students (groups) will:
 - List the colors of the bricks they used across the top of a sheet of paper to establish columns for ordered pairs of data.
 - Place their panel on a blank T-24 template.
 - Determine the ordered pairs for each of the bricks on their panel and enter that data in the appropriate column on their data sheet.
 - Use crayons or markers and transfer their image to a blank T-24 template.
(This will later be used to check the work of others who follow their data to form the image.)
 - Exchange data sheets with another student (group) and use a blank T-24 template to recreate the image the data indicates.
- Use a teacher designed data sheet of ordered pairs as a challenge activity or a quiz.

Lesson Topic: Letter Recognition and usage of capital/lowercase letters

Grade: K-1 **Lesson Length:** 30 minutes

Student Objectives

Students will:

- create letters using bricks
- gain a deeper understanding of letter usage and formation
- practice using upper and lower case letters

Grouping for Instruction

- Whole group for introduction, instruction, and closure
- Partners or small group for investigation

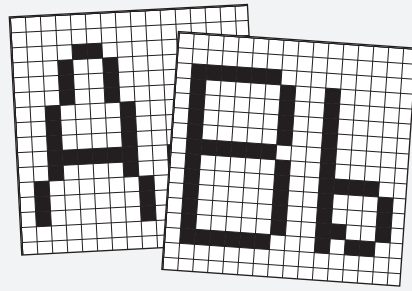

Materials and Equipment

- Eight panels
- Green K'NEX Bricks
- Four Copies of Templates T-11 and T-12
- Overhead projector

PROCEDURE

- Project a hand written, capital letter 'D' on the screen with the overhead projector. Ask students to identify it and to give examples of where they might see a capital letter (names of people, signs on restaurants, titles of books, etc).
- Add the lowercase 'd' and again ask students to identify where they may have seen this lowercase letter.
- Compare the capital and lowercase letter in terms of size
- Instruct students that they will be creating a capital and lowercase letter on their panel.
- One half of the students/groups will make a capital and lowercase 'A' using Template T-11 and the other half will make a capital and lowercase 'B' using Template T-12.
- Distribute the all necessary materials to students.
- Have students complete their letters.
- Ask students to name their letter and to give an example of words they might see that have a capital letter A or B or a lowercase letter a or b.
- Repeat the questioning with each of the eight students or groups who have participated in the activity.

SUMMARY AND CLOSURE

- Ask students to talk with a partner and write down what they did today in class.
- Ask students to talk with that same partner and to write down what they learned today in class.
- Have students identify words that contain capital A's or B's, and words that contain lowercase a's and b's.
- Have students share with the class the difference between properly formed upper and lowercase letters.

ASSESSMENT

- Have students independently form a capital and lowercase letter using the colored bricks and a panel.
- Ask students to write words that begin with a capital A or B. A lower case a or b. Collect and evaluate students' lists of words.

Lesson Topic: Letter Building**Grade:** K-1 **Lesson Length:** 45 minutes**Student Objectives**

Students will:

- demonstrate spatial relationship skills
- build capital letters
- state words that begin with assigned capital letters

Grouping for Instruction

- Whole group for introduction, instruction, and closure
- Partners or small group for investigation

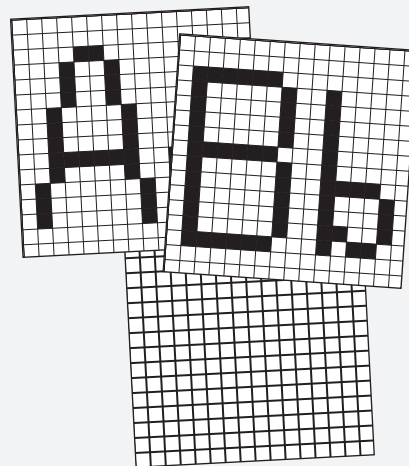
**Materials and Equipment**

- Eight panels
- Green K'NEX Bricks
- Eight templates – T-23
- Four each of templates T-11 and T-12
- Overhead projector

PROCEDURE

- Project a capital letter on the overhead projector and ask the students to share what they know about the formation and usage of capital letters
- In advance create a capital letter 'A' with bricks on a panel that is formed correctly and one that is formed incorrectly on a separate panel. Have students identify the differences. Students must decide which letter is formed correctly.
- Create a list of criteria for a correctly formed capital letter. Allow students to refer to templates T-11 and T-12 and the panels you have just presented.
- Create a list of criteria for the correct usage of capital letters (Builds on the Letters Part 1 lesson). Post these lists on easel paper or on a section of the board where they can remain for several days.
- Distribute materials to students.
- Divide the students into partners or small groups and assign each a different letter to create (C, D, O, R, T, F, E, and L). Some students may need templates for their letters. Files with these templates can be found on the CD that came with your set.
- Share with class by standing the panels on the chalk rail or placing them on a table for all to see.
- Hand a letter to a student and ask them to say a word that begins with that capital letter. Repeat the activity with all of the students. Use the letters as many times as is necessary to provide a chance for all students.
- Have students use Template T-23 to fill in the appropriate squares to match the letters they have produced.
- Save the panels and templates for the Letters Part 3 activity.

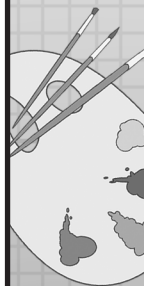

SUMMARY AND CLOSURE

- Ask students to talk with a partner and write down what they did today in class.
- Ask students to talk with that same partner and to write down what they learned today in class.
- Have students share with the class how to properly form uppercase letters.
- Have students share the capital letters that begin their first and last names.

ASSESSMENT

- Have students switch panels with another group and have that group determine if the letters were properly created following the criteria list generated by the class.
- Collect data as to the students' ability to correctly state words starting with the capital letters you handed to them during the earlier activity.
- Collect and evaluate the Template T-23 papers completed by students.

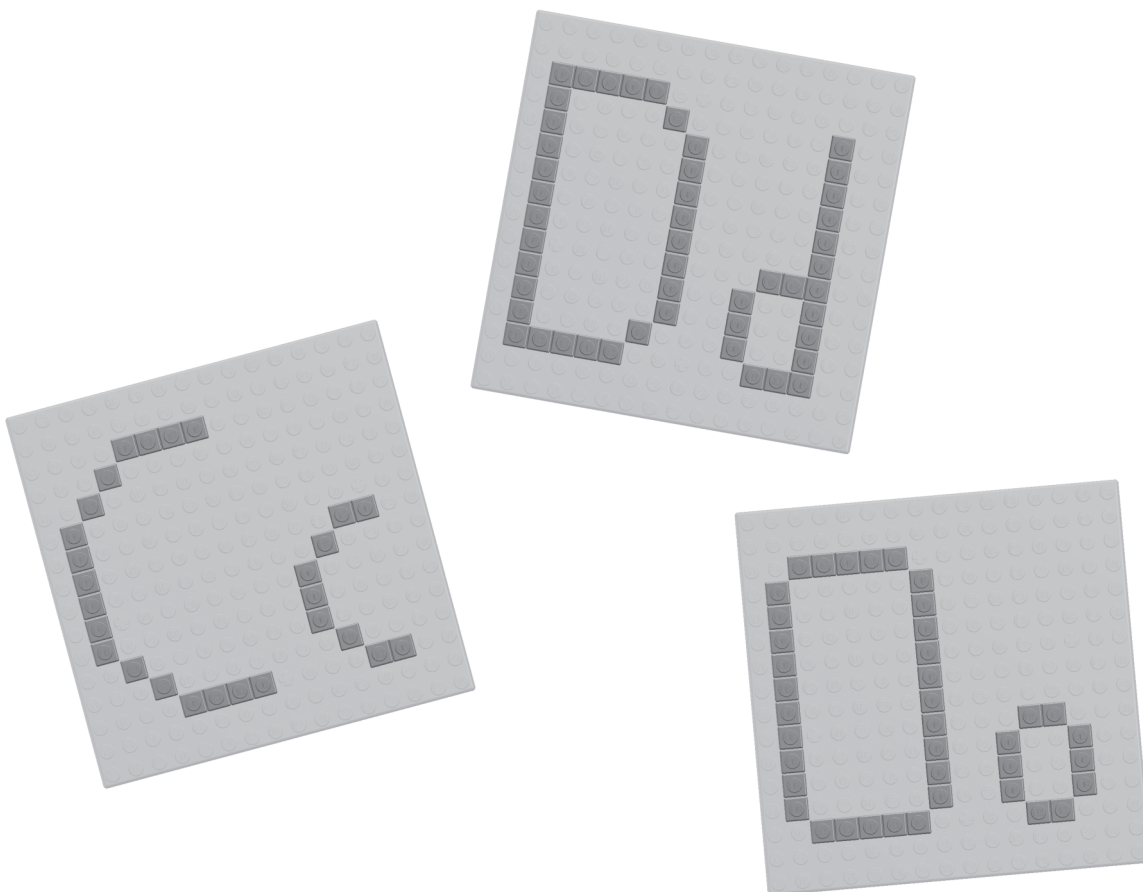

Lesson Topic: Letter recognition and usage of capital/lowercase letters

Grade: K-1 **Lesson Length:** 30 minutes

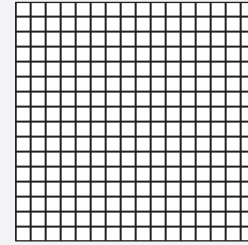

Student Objectives

Students will:

- build letters
- gain a deeper understanding of letter usage and formation
- combine letters to form simple words

Grouping for Instruction

- Whole group for introduction, instruction, and closure
- Partners or small group for investigation

Materials and Equipment

- Eight panels
- Green K'NEX Bricks
- Overhead projector
- Template T-23

PROCEDURE

- Project a capital letter and a lowercase letter on the overhead projector and ask students to compare the spatial relationship between the two. How are they different and how they are the same?
- Show students letters C, D, O, R, T, F, E, and L from the previous activity and review the criteria for a correctly formed capital letter. (If these are not available, distribute the templates the students prepared for these letters in the Letters Part 2 activity so students can construct the letters quickly.)
- Distribute materials
- Divide the students into partners or small groups
- Have students create lowercase matches to the aforementioned letters. Students may refer to letter charts or writing books for ideas as to the correct format for the letters.
- Share the lowercase letters with the class. Allow students to select the best representations of the assigned lowercase letters from their classmates' panels.
- Ask students to make templates for their lowercase letters.
- Place the student prepared panels on a table and ask students if they can think of any words that could be made using some or all of the letters on the table.
- Put panels together to form words that are offered by students.
- The CD that accompanies your set includes templates for all of the letters of the alphabet if you would like students to use those for this activity.



SUMMARY AND CLOSURE

- Ask students to talk with a partner and write down what they did today in class.
- Ask students to talk with that same partner and to write down what they learned today in class.
- Have students share with the class how to properly form lowercase letters.

ASSESSMENT

- Observe the students during the activity and use anecdotal note cards to record your observations.
- Evaluate the students' ability to create lowercase letters on a panel.
- Make a series of panels to form a long word for the day.
 - Post the panels in order on the chalk rail or on a classroom table.
 - Ask students to create a list of words they can make from the letters in the long word you have displayed.
 - Students may keep the list and add to it throughout the day.
(You may use and emphasize words that can be made from the letters to provide some clues to the students as you present lessons during the day.)
- Establish a K'NEX Explorations in Science, Math and Literacy center in the back of the classroom.
 - Provide a supply of T-23 templates and ask students to design lowercase letters that were not used in class.
 - Instruct students to place their name on the back of any templates they make for the letters they have designed before handing in their work.

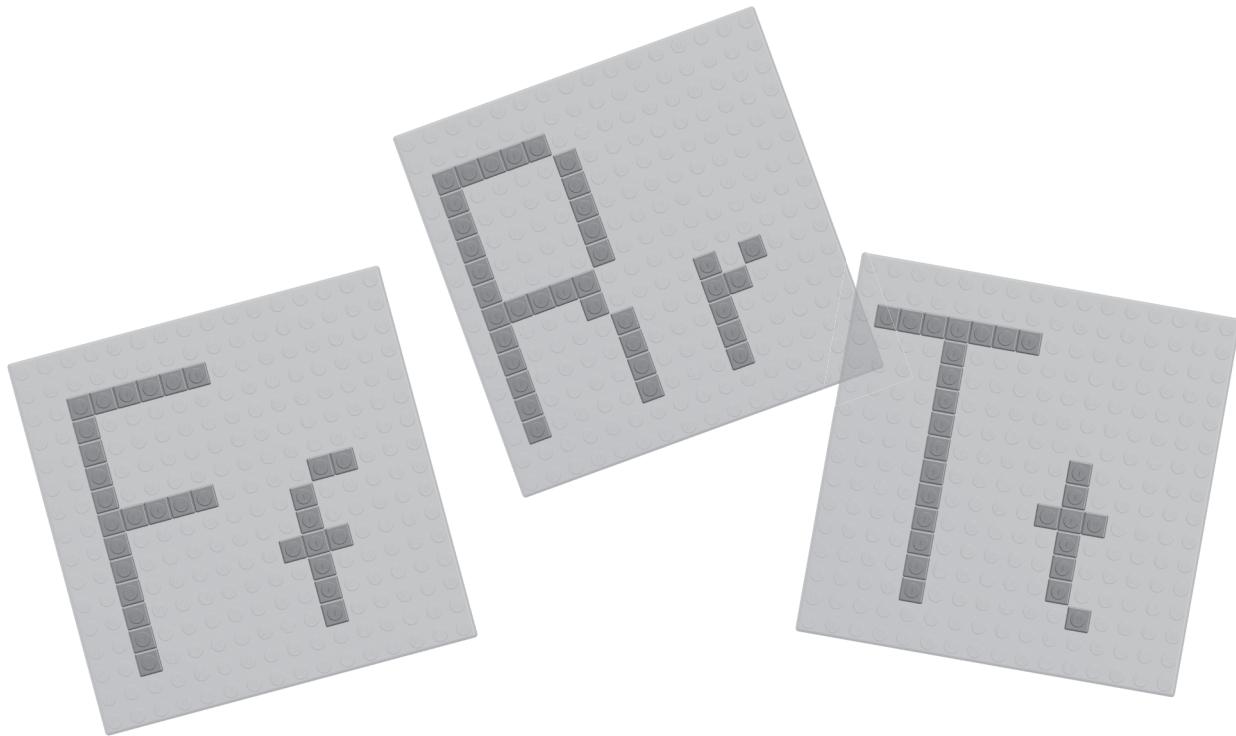

Lesson Topic: Letter and word creation

Grade: 1-3 **Lesson Length:** 30 minutes

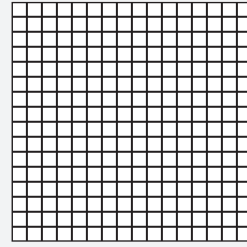

Student Objectives

Students will:

- create models of lowercase letters
- build words by rearranging letter panels

Grouping for Instruction

- Whole group for introduction and word round-robin game
- Individual or partners for letter building and creating word lists

Materials and Equipment

- Eight panels
- Copies of template T-23
- Green K'NEX Bricks
- Paper and pencils

PROCEDURE

- Divide the class into partners, small groups, or allow students to work independently for the first part of this activity.
- Distribute all necessary materials to students.
- Have students draw letters from a hat and create a lowercase model of the letter they have drawn. (The teacher selects letters to be used that follow word families that are part of the curriculum.) Students should make a template of their letters using T-23.
- Instruct students to sit in a circle and to place their letter models in the center of the circle.
- Select a student to think of a word that can be made from as many of the letters in the circle as possible.
- Have that child move the panels to spell the word. The child collects one point for each letter successfully used to form a word.
- The next student forms a new word and collects points.
- Continue as long as the students are successful. Students will learn from each other's observations and the quality of responses will improve as the activity continues and is repeated with other letters in the future.
- Instruct students that they will now complete a word list on their own from what they remember from the activity. Display the panels and have students independently list as many words as possible.

SUMMARY AND CLOSURE

- Ask each student to share one word that they identified. Organize the panels to form that word for all to see.
- Ask students to describe what they have learned in class today.

ASSESSMENT

- Students turn in lists of words they have generated.
- Increase the difficulty of the activity with the letters you choose for the students to build words from.
- Keep track of the students' scores during the game. (Teacher Note: This is an activity that can be utilized over and over again in the classroom or as a learning center in the back of the room to strengthen students' skills with letters and words. Select letter combinations that will initially enable all to be successful and then gradually increase the difficulty of the task.)

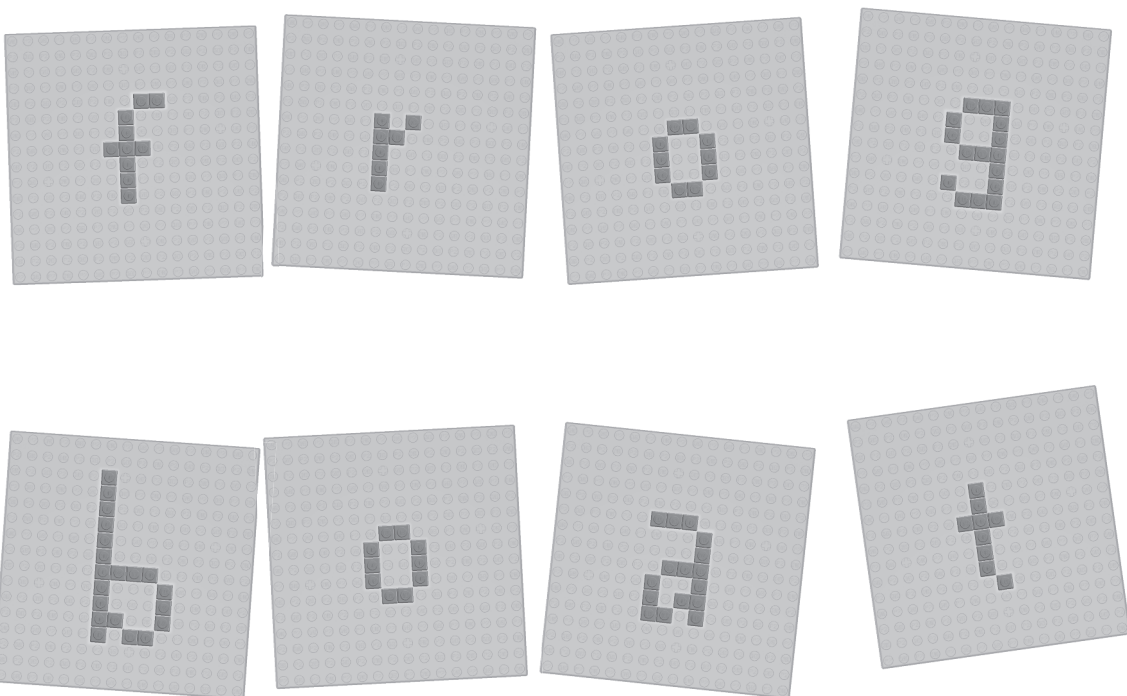

Lesson Topic: Characteristics of Organisms**Grade:** 1-3 **Lesson Length:** 45 minutes**Student Objectives**

Students will:

- construct images of organisms
- identify some of the characteristics of organisms shown by the images
- compare the characteristics of various organisms

Grouping for Instruction

- Whole group for introduction, instruction, and closure
- Partners or small group for investigation

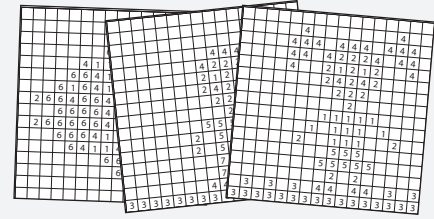
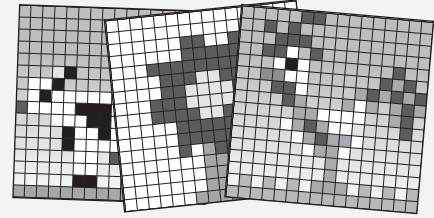
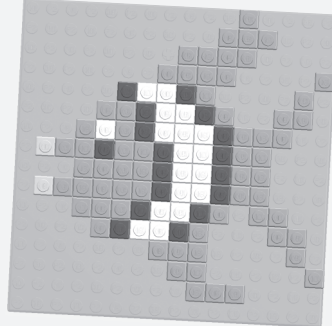
**Materials and Equipment**

- Eight panels
- K'NEX Bricks
- Two or more copies each of templates T-2, T-3, T-4, T-6, T-7, and T-8

NSES Science Content Standards Adressed

- Life Science
 - The characteristics of organisms

(Reprinted with permission from "National Science Education Standards", © 1995 by the National Academy of Sciences, Courtesy of the National Academies Press, Washington, D.C.)



PROCEDURE

- Randomly distribute the templates to students and ask them to create the image shown.
- Ask a student to show and identify the organism they have constructed.
- Ask the student to list as many characteristics of the organism as they can. (i.e., Fish – fins, gills, scales, etc.) (You may wish to write these on the board or easel paper as they are listed.)
- Can other members of the class add additional characteristics?
- Repeat the process for several of the different creatures that the students have created. For younger students you may have to continue writing their offerings on the board or easel paper. For older students, they can prepare lists of their own.
- Have two students hold up their panels and ask students to describe what characteristics are shared by both organisms. What characteristics are found only in one of the organisms?

SUMMARY AND CLOSURE

- Ask students to talk with a partner and write down what they did today in class.
- Ask students to talk with that same partner and to write down what they learned today in class.
- Ask several students to share their responses with the class or with partners.
- Utilize probing questions to explore students' understanding.

ASSESSMENT

- Observe the students during the activity.
- Use anecdotal note cards and/or check lists to record your observations.
- Collect and evaluate any lists students have prepared.
- Challenge Activity: Instruct students to create images of other creatures they know using K'NEX Bricks and Panels. Ask the students to list some of the characteristics of the organisms they have created. This activity may be appropriate for a science center in the classroom.

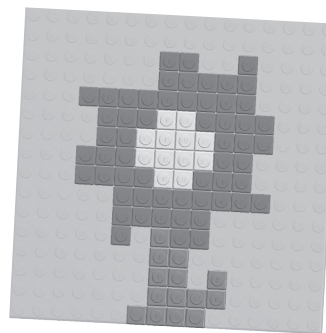

Lesson Topic:
Environments Organisms Live In

Grade: 2-3 **Lesson Length:** 45 minutes

Student Objectives

Students will:

- construct images of organisms
- identify some of the needs of those organisms
- identify environments where their organisms live and are able to meet their needs

Grouping for Instruction

- Whole group for introduction, instruction, and closure
- Partners or small group for investigation

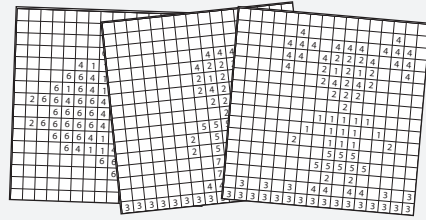
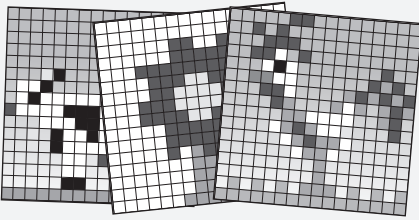

Materials and Equipment

- Eight panels
- K'NEX Bricks
- Two or more copies each of templates T-2, T-3, T-4, T-6, T-7, T-8

NSES Science Content Standards Adressed

- Life Science
 - Organisms and environments

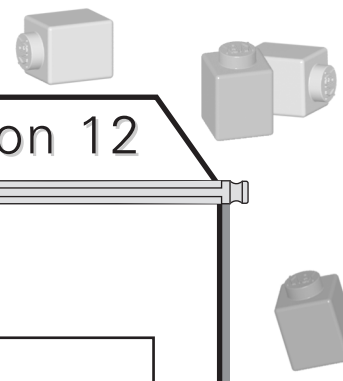

PROCEDURE

- Randomly distribute the templates to students and ask them to create the image shown.
- Ask a student to show and identify the organism they have constructed.
- Ask the student to describe what that organism would need to survive. (Cow: air, water, warm temperatures, plenty of grass, etc.)
- Can other members of the class add additional needs that the organism would require in order to survive?
- What type of environment would the organism have to live in to enable its needs to be met? (Cow – meadow; Fish - river or stream)
- Repeat the process for several of the different creatures that the students have created. (For younger students you may have to continue writing their offerings on the board or easel paper. For older students, they can prepare lists of their own.)
- Ask students if all of the organisms live in the same locations or environments. Can they explain why organisms must live in different environments? If not, help the students to understand that organisms have different needs that may only be met by certain environments.

SUMMARY AND CLOSURE

- Ask students to talk with a partner and write down what they did today in class.
- Ask students to talk with that same partner and to write down what they learned today in class.
- Ask several students to share their responses with the class or with partners.
- Utilize probing questions to explore students' understanding.

ASSESSMENT

- Observe the students during the activity.
- Use anecdotal note cards and/or check lists to record your observations.
- Collect and evaluate any lists students have prepared.
- Challenge Activity: Instruct students to create images of other creatures they know using the K'NEX bricks. Make a list of the organisms' needs and describe the environment that would give the organism the best chance of survival.

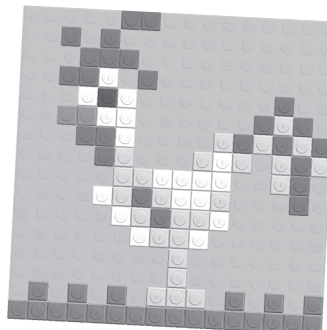
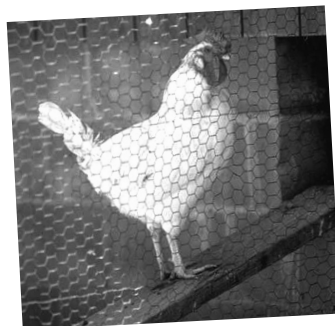

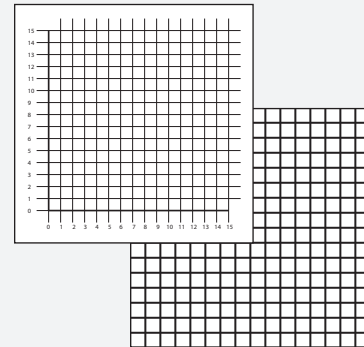
Lesson Topic: Bar Graphs**Grade:** 1-3 **Lesson Length:** 30-40 minutes**Student Objectives**

Students will:

- collect data from classmates
- tabulate collected data and produce a bar graph that correctly displays information
- develop a deeper understanding of bar graphs

Grouping for Instruction

- Whole group for introduction, instruction, and closure
- Partners or small group for investigation

Materials and Equipment

- Eight panels
- K'NEX Bricks
- Paper and pencil
- Copies of bar graph examples (From the newspaper, internet, textbook, or workbook)
- Copies of template T-21

NSES Science Content Standards Addressed

- Science as Inquiry
 - Abilities necessary to do scientific inquiry
 - Understanding about scientific inquiry

NCTM Standards and Expectations Addressed

- Formulate questions that can be addressed with data and collect, organize, and display relevant data to answer them
 - sort and classify objects according to their attributes and organize data about the objects
 - represent data using concrete objects, pictures, and graphs
 - design investigations to address a question and consider how data-collection methods affect the nature of the data set
 - collect data using observations, surveys, and experiments
 - represent data using tables and graphs such as line plots, bar graphs, and line graphs.

Standards are listed with permission of the National Council of Teachers of Mathematics (NCTM). NCTM does not endorse the content or validity of these alignments.

PROCEDURE

- Give each group a picture of a bar graph and ask them to interpret the information it is displaying.
- After each group has shared their information tell them that in today's lesson they will be building their own bar graph using the panels to represent the paper and K'NEX Bricks to form the bars.
- Distribute panels and bricks
- Instruct the groups to pick a topic to survey the class about e.g. favorite sport, favorite ice cream flavor, etc.
- Have the groups survey everyone in the class and record the data on a piece of paper. (Carefully observe how the students collect and organize the data.)
- When everyone has been surveyed each group should begin to build a bar graph on their panel that displays the information that they have gathered.
 - Provide copies of T-21 or T-23 for this activity.
 - Students should list the choices their classmates had to select from along the X-axis of the graph.
 - Students will use bricks to form the bars above each of the choices.
- Students will share bar graphs with the class and explain what their graph shows.
- Students should transfer their graph to the template they have chosen, place their name on the back of the template, and staple it to their data sheet before handing in their papers.

SUMMARY AND CLOSURE

- Ask students to talk with a partner and write down what they did today in class.
- Ask students to talk with that same partner and to write down what they learned today in class.
- Ask several students to share their responses.

ASSESSMENT

- Evaluate the data table of collected information and the representation of that information in bar graph form.
- Collect the completed bar graphs and call each student up to the teacher's desk and give the student a bar graph that is different than the one they worked on. Ask the student to interpret the information on this new graph.
- Challenge Activity: Encourage students to collect data related to other questions and to graph that information with panels and bricks. The materials for this challenge could be provided to students in a science and math center in the classroom.

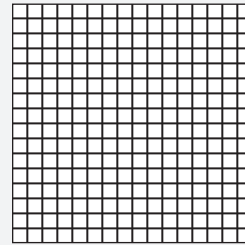
Lesson Topic: Graphing**Grade:** 2-3 **Lesson Length:** 30-40 minutes**Student Objectives**

Students will:

- gain a deeper understanding of graphing skills
- create a bar graph from a set of data
- discover that bar graphs represent specific data
- answer questions pertaining to the bar graph that they create

Grouping for Instruction

- Whole group for introduction, instruction, and closure
- Partners or small group for investigation

Materials and Equipment

- Paper, pencils, crayons/colored pencils/markers
- Eight T-23 Grids
- Eight panels
- K'NEX Bricks

Each student (or pair) should be limited to a handful of no more than:

- 15 black bricks
- 13 yellow bricks
- 15 red bricks
- 15 green bricks
- 15 white bricks
- 15 orange bricks
- 5 blue bricks

NSES Science Content Standards Adressed

- Science as Inquiry
 - Abilities necessary to do scientific inquiry
 - Understanding about scientific inquiry

NCTM Standards and Expectations Addressed

- Formulate questions that can be addressed with data and collect, organize and display relevant data to answer them
 - sort and classify objects according to their attributes and organize data about the objects;
 - represent data using concrete objects, pictures, and graphs;
 - represent data using tables and graphs such as line plots, bar graphs and line graphs.
- Use mathematical models to represent and understand quantitative relationships
 - model problem situations with objects and use representations such as graphs, tables, and equations to draw conclusions.

Standards are listed with permission of the National Council of Teachers of Mathematics (NCTM). NCTM does not endorse the content or validity of these alignments.



PROCEDURE

- Distribute all necessary materials to students, giving each student or group a random handful of colored bricks (totals not to exceed the limits listed above). Every student or group will have a different supply of bricks.
- Instruct students to sort and count the number of various colors given to them by the teacher.
- Have students build a real bar graph using their bricks and a panel to show how many bricks of each color they have in their collection.
- Have the students use a T-23 Template to make a representational bar graph of their data. Students should color in the squares on their graphs with the appropriate colors. Instruct students to add labels and a title to their graph on the template.
- Place the templates on a table and place a single letter from A to H under each.
- Place the piles of bricks from each team on the table with a single number from 1 to 8 under each.
- Provide students with a sheet of paper and ask them to match the pile of bricks to the appropriate template using the letter and number designations. (i.e., A-4, B-7, etc.)

SUMMARY AND CLOSURE

- Ask students to talk with a partner and write down what they did today in class.
- Ask students to talk with that same partner and to write down what they learned today in class.
- Ask several students to share their responses with the class or with partners.
- Use probing questions to explore students' understanding.

ASSESSMENT

- Observe the students during the activity and collect their work.
- Use anecdotal note cards and/or check lists to record your observations.
- Compare the real and representational graphs to determine if they are correct representations of the data.
- Set up a performance testing station where students can independently complete a similar bar graph with a different collection of bricks or other classroom items.

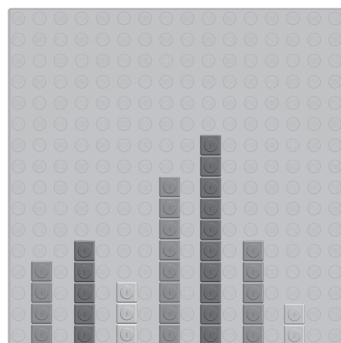

Lesson Topic:
Math - Building Numeric Digits

Grade: 1 **Lesson Length:** 30 minutes

Student Objectives

Students will:

- build numeric digits (0 – 9)
- gain a deeper understanding of numbers and their formation
- develop understanding of the relative position and magnitude of whole numbers and of ordinal and cardinal numbers and their connections

Grouping for Instruction

- Whole group for introduction, summary, and closure
- Partners or small group for investigation

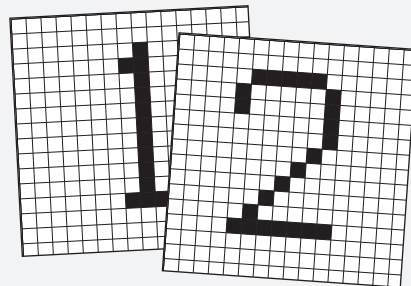

Materials and Equipment

- Eight panels
- Green K'NEX Bricks
- Four copies of template T-9
- Four copies of template T-10

NCTM Standards and Expectations Addressed

- Understand numbers, ways of representing numbers, relationships among numbers, and number systems
 - develop understanding of the relative position and magnitude of whole numbers and of ordinal and cardinal numbers and their connections.

Standards are listed with permission of the National Council of Teachers of Mathematics (NCTM). NCTM does not endorse the content or validity of these alignments.

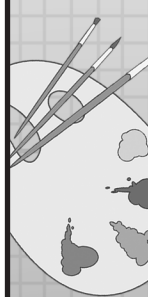

PROCEDURE

- Distribute the materials to the students.
- Have students work with a partner or small group to complete the activities.
- Part # 1
 - Provide half of the students (groups) with a copy of template T-9 and the other half with template T-10.
 - Instruct students to create the number shown on their template with green bricks.
 - Have students hold up their creations to verify successful completion of the activity.
 - Exchange templates and repeat the instructions above.
- Part # 2
 - Using the template they now hold as a guide, students will make another number on their panel.
 - Instruct students to build a number '4' on their panel using green bricks. The new number should be the same size as the number on their template.
 - Have students hold up their creations to verify successful completion of the activity.
 - Ask students how many bricks tall the number was on their template. Then ask them how tall their '4' is to ensure that they have a number that is the same size as their template.
 - Check their work to ensure that the width of their '4' is reasonable. If not, this is an opportunity to extend instruction to improve students' spatial relationship skills.
- Share images with the entire class.

SUMMARY AND CLOSURE

- Ask students to talk with a partner and write down what they did today in class.
- Ask students to talk with that same partner and to write down what they learned today in class.
- Ask several students to share their responses with the class or with partners.
- Use probing questions to explore students' understanding.

ASSESSMENT

- Assign the other numbers '3, 5, 6, 7, 8, 9, and 0' to various groups so they can create those numbers using bricks. Check the panels to determine if the numbers are representative of the numbers found on templates T-9 and T-10.
- Assign the entire group of eight students or eight groups to work together to produce numbers '0 to 7' that are three bricks shorter than the numbers on templates T-9 and T-10.

Lesson Topic:

Mathematics - Place value

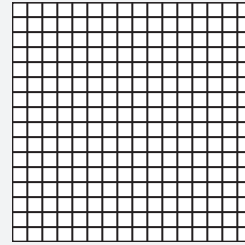
Grade: 1-2 **Lesson Length:** 45 minutes**Student Objectives**

Students will:

- create models of numeric digits
- build numbers using bricks
- develop and demonstrate a deeper understanding of place value

Grouping for Instruction

- Whole group for introduction, instruction, and closure
- Partners or small group for investigation
- The preceding “Number Building” activity should be completed prior to this activity.

Materials and Equipment

- Eight panels
- Green K’NEX Bricks
- Eight copies of template T-23
- Paper and pencils

NCTM Standards and Expectations Addressed

- Understand numbers, ways of representing numbers, relationships among numbers, and number systems
 - use multiple models to develop initial understandings of place value and the base-ten number system.

Standards are listed with permission of the National Council of Teachers of Mathematics (NCTM). NCTM does not endorse the content or validity of these alignments.

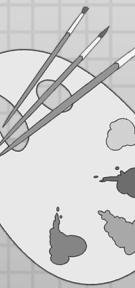

PROCEDURE

- Demonstrate how to properly place bricks on a panel.
- Divide the class into partners, small groups, or allow students to work independently.
- Distribute all necessary materials to students.
- Assign each student or group of students a digit to build on their panel (select from 1, 2, 3, 4, 5, 6, 7, and 8). Ask students to use template T-23 to make a paper version of the number they have created.
- After all eight digits have been created; have four of the groups sit at different places around the room with their panels.
- Have the other four groups pair up with one of the sitting groups and place their panels together to form the largest number they can and then the smallest number they can. Students should record their data listing the digits they began with and the largest number and the smallest number they were able to form.
- Have students rotate through the groups and continue to build the largest and smallest number possible using both panels. Data should be recorded for each of the groups they visit.
- Have four groups combine their panels (there will now be two groups in the classroom) and build the largest and smallest numbers possible using all four of the digits they have on their panels.
- Increase the number of groups or the number of digits for each group by incorporating the paper versions of the digits that the students prepared earlier in the activity.

SUMMARY AND CLOSURE

- Ask students to list the largest number they were able to make using two digits.
- Ask students to list the smallest number they were able to make using two digits.
- Repeat the question for four digits.
- Hold up three digits or place them on the chalk board rail. Ask students to list the smallest and largest numbers they can make from those digits.

ASSESSMENT

- Hold up two panels with digits and ask students to list the largest and smallest numbers possible with those digits. Repeat the activity with more and more digits. As you add additional digits, consider adding two of the same digit i.e., 3, 4, 2, 4.
- During a test or quiz while students are completing questions at their desks, have students rotate through a series of stations around the room where you have placed panels with digits. Include a question at each station that asks students to determine and list the largest or smallest number they can form with the digits provided.

Lesson Topic: Mathematics - Place value

Grade: 1-2 **Lesson Length:** 30 minutes

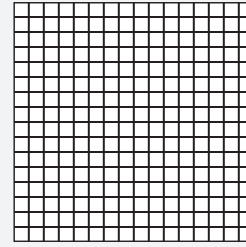

Student Objectives

Students will:

- create models of numeric digits
- build numbers using panels and bricks
- develop a deeper understanding of place value

Grouping for Instruction

- Whole group for introduction, instruction, and closure
- Partners or small group for investigation

Materials and Equipment

- Eight panels
- Green K'NEX Bricks
- Eight copies of Template T-23 (or use the templates developed in the previous Place Value activity).
- Paper and pencils

NCTM Standards and Expectations Addressed

- Understand numbers, ways of representing numbers, relationships among numbers, and number systems
 - Use multiple models to develop initial understandings of place value and the base-ten number system;
 - Develop understanding of the relative position and magnitude of whole numbers and of ordinal and cardinal numbers and their connections.

Standards are listed with permission of the National Council of Teachers of Mathematics (NCTM). NCTM does not endorse the content or validity of these alignments.

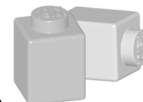
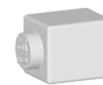

**PROCEDURE**

- Demonstrate how to properly place bricks on a panel.
- Divide the class into partners, small groups, or allow students to work independently.
- Distribute all necessary materials to students.
- Assign each student or group of students a digit to build on their panel using green bricks. Have them use their pencils and template T-23 to make a paper version of the number they have formed.
- Instruct students to sit in a circle and place their number models in the center of the circle.
- Select a student to think of a number that can be made out of two of the digits in the circle.
- Have that student arrange the panels to form that number. Ask the student to say the number they have formed and to indicate what place value each digit holds.
- Ask students if a different number could be built using the same two digits. Have a volunteer show the class by moving the panels into the new position.
- Since the students now understand the activity, split the class into two groups. One group will use the panels for practice activities and the other group will use the paper templates that the students have produced. Ask for other two digit numbers to be built and then three digit, four digit, etc. from the panels or templates in the circles. In each case ask students to state the number they have formed with the panels and to describe what place value each digit holds. The two group format provides more opportunities for each student to practice their skills and demonstrate their understanding.
- Continue for about 10 – 15 minutes. Students will learn from each other's observations and the quality of responses will improve as the activity continues.
- Instruct students that they will now complete number lists on their own.
- Display panels and have students independently list as many numbers as possible (two digit numbers up to eight digit numbers, but only using the digit once in any particular number).

SUMMARY AND CLOSURE

- Ask each student to share one number that they identified and what place value each digit holds.

ASSESSMENT

- Given a list of digits have students build various numbers (e.g. largest three digit number or smallest four digit number). Have students independently state the number they have formed and identify the place value each digit holds.

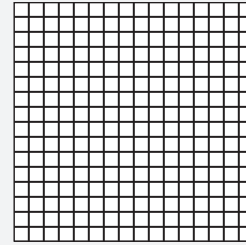
Lesson Topic: Number Sentences**Grade:** 2**Lesson Length:** 30 minutes**Student Objectives**

Students will:

- use concrete objects, including number lines, to find the solution to addition and subtraction problems with one and two digit numbers (no regrouping)
- build number sentences that are true
- determine if a number sentence is true or false

Grouping for Instruction

- Whole group for introduction, instruction, and closure
- Partners or small group for investigation

Materials and Equipment

- Eight panels
- Green K'NEX Bricks
- A set of operation (+, -) and relationship (>, <, =) cards. Each on a 3" X 5" card with bold marker.
- Eight copies of template T-23

NCTM Standards and Expectations Addressed

- Understand numbers, ways of representing numbers, relationships among numbers, and number systems
- Compute fluently and make reasonable estimates
 - develop and use strategies for whole number computations, with a focus on addition and subtraction.

Standards are listed with permission of the National Council of Teachers of Mathematics (NCTM). NCTM does not endorse the content or validity of these alignments.

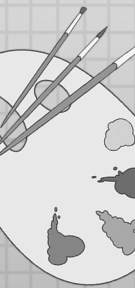

PROCEDURE

- Distribute all necessary materials to students.
- Assign each student or group of students a digit to build on their panel with colored bricks.
- Instruct students to sit in a circle and place their number models in the center of the circle.
- Also, place the different operation symbols (+, -), and relationship symbols (>, <, =) in the circle.
- Select a student to think of a number sentence that can be made out of the digits and symbols in the circle.
- Have that student move the panels and symbol cards to build the number sentence. Ask the student to read the number sentence they have formed. (i.e., $4 + 2 = 6$ or $7 > 3$)
- Ask the remainder of the class if they agree or not.
- Instruct the students that if the number sentence gives you the correct answer then it is considered to be true, but if it does not give you the correct answer that it is considered to be false.
- Have a volunteer come up and build a number sentence that is false.
- Continue to have the students build, state and evaluate various number sentences.
- Instruct students that they will now complete number sentences on their own at their desks.
- Display three or more panels and two or more symbols and have the students independently list on paper as many true number sentences and false number sentences as possible with the numbers and symbols you have provided.

SUMMARY AND CLOSURE

- Ask students to talk with a partner and write down what they did today in class.
- Ask students to talk with that same partner and to write down what they learned today in class.
- Ask several students to share their responses with the class or with partners.
- Use probing questions to explore students' understanding.

ASSESSMENT

- Observe the students during the activity.
- Use anecdotal note cards to record your observations.
- Have students independently create true and false number sentences first with panels and symbols and then on a sheet of paper.
- Add operation symbol cards for multiplication and division when students are prepared to address these operations.

Lesson Topic:

Mathematics - Calculations With Money

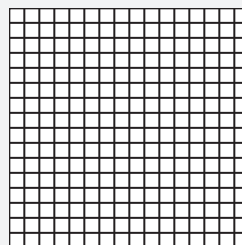
Grade: 3 **Lesson Length:** 45 minutes
(each section)**Student Objectives**

Students will:

- create a design using K'NEX Bricks
- calculate the value of their creation using a chart that assigns a value to each color brick
- create designs that have a value equal to a given amount

Grouping for Instruction

- Whole group for introduction, instruction, and closure
- Partners or small group for investigation

Materials and Equipment

- Eight panels
- K'NEX Bricks
- Sixteen copies of template T-23
- Pencils and scratch paper
- Colored pencils or crayons
- Calculators (optional)

NCTM Standards and Expectations Addressed

- Understand numbers, ways of representing numbers, relationships among numbers, and number systems
- Understand meanings of operations and how they relate to one another
 - understand various meanings of addition and subtraction of whole numbers and the relationship between the two operations;
 - understand the effects of adding and subtracting whole numbers.
- Compute fluently and make reasonable estimates
 - develop and use strategies for whole-number computations, with a focus on addition and subtraction;
 - develop fluency in adding, subtracting, multiplying, and dividing whole numbers;
 - Develop and use strategies to estimate the results of whole-number computations and to judge the reasonableness of such results.

Standards are listed with permission of the National Council of Teachers of Mathematics (NCTM). NCTM does not endorse the content or validity of these alignments.

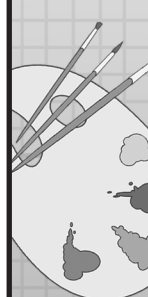

PROCEDURE

ACTIVITY 1

- Divide the class into partners or small groups.
- Provide each group with a clear panel and a collection of bricks.
- Ask each group to create an image of their own design.
- Post the chart below on the screen or chalk board and ask students to find the value of their model based on the piece costs that are listed. Record the value.

- Each color brick has a value:

Black = \$0.05

Yellow = \$0.10

Red = \$0.12

Green = \$0.15

White = \$0.25

Orange = \$0.50

Blue = \$0.60

- Ask students to exchange panels with another group and compute the value of their creation.
- Have students compare the values they determined with the values the other group found. If differences are discovered, instruct groups to uncover the error.
- Instruct students to prepare a color template of their creation and to place its value on the back of the template along with their name(s).

ACTIVITY 2

- Announce to the class that they are to develop an image with a predetermined value. (For example \$ 8.37)
- Allow students sufficient time to gather their pieces and to create their image.
- At the conclusion of the activity, students will exchange panels and check each other's work

SUMMARY AND CLOSURE

- Ask students to talk with a partner and write down what they did today in class.
- Ask students to talk with that same partner and to write down what they learned today in class.
- Ask several students to share their responses with the class or with partners.
- Use probing questions to explore students' understanding.

ASSESSMENT

- Observe students as they work. Take notes as to their strategies and approaches to the problems. Do they use mostly addition skills? Do they incorporate multiplication skills? Etc.
- Have students independently build an image that has a set value using a panel and colored bricks. Students will then prepare a color template of their creation with the value written on the back along side their name.

Lesson Topic: Mathematics - Polygons

Grade: 3 **Lesson Length:** 45 minutes

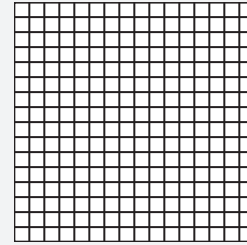

Student Objectives

Students will:

- identify attributes of two-dimensional shapes
- recognize, describe, or extend a variety of patterns
- build shapes using concrete objects
- identify shapes produced from colored bricks

Grouping for Instruction

- Whole group for introduction, instruction, and closure
- Partners or small group for investigation

Materials and Equipment

- Eight panels
- Green K'NEX Bricks
- Chart paper
- Markers
- Shapes/Reflections
- Templates: (2 of each)
 - T-13: Large Square
 - T-14: Octagon
 - T-15: Triangle
 - T-16: Pentagon

NCTM Standards and Expectations Addressed

- Analyze characteristics and properties of two- and three- dimensional geometric shapes and develop mathematical arguments about geometric relationships
 - recognize, name, build, draw, compare, and sort two- and three- dimensional shapes;
 - describe attributes and parts of two- and three- dimensional shapes;
 - identify, compare, and analyze attributes of two- and three- dimensional shapes and develop vocabulary to describe the attributes.
- Use visualization, spatial reasoning, and geometric modeling to solve problems
 - build and draw geometric objects.

Standards are listed with permission of the National Council of Teachers of Mathematics (NCTM). NCTM does not endorse the content or validity of these alignments.



**PROCEDURE**

- Introduce the students to polygons and their properties (attributes).
- Distribute all necessary materials to students. Each student or group will receive one of the templates at random.
- Instruct students to place a panel on top of their template and to create the image by following the pattern.
- Have each group show their image to the class
- Divide the class into two groups each with one set of distinct images on their panels.
- Have each group form a circle and place the panels in the center.
- Select a student to choose a panel with a polygon on it.
- Have that child name the shape and pass the shape to the person to their right.
- The next student states a different name or an attribute for that same polygon. Continue passing the panel until the possible responses have been exhausted.
- Continue with the other shapes in the circle. Students will learn from each other's observations and the quality of responses will improve as the activity continues to the second, third and fourth polygon.
- Display the panels around the classroom with a piece of chart paper along side each and have students work in small groups or partners to visit each panel. Students are to list one new name or attribute to each of the chart papers. Complete as many rounds as necessary to provide a complete list of names and attributes for the various shapes.

SUMMARY AND CLOSURE

- Ask students to talk with a partner and write down what they did today in class.
- Ask students to talk with that same partner and to write down what they learned today in class.
- Ask several students to share their responses with the class or with partners.
- Use probing questions to explore students' understanding.

ASSESSMENT

- Observe the students during the activity.
- Use anecdotal note cards to record your observations.
- Have students independently identify attributes of a polygon model that they are shown.
- Have students design other polygons with their bricks and panels. Instruct them to complete a new piece of chart paper with the names and attributes of the polygon they have created.

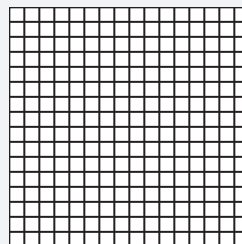
Lesson Topic: Polygons**Grade:** 2-3 **Lesson Length:** 45 minutes**Student Objectives**

Students will:

- identify attributes of two-dimensional shapes
- recognize, describe, or extend a variety of patterns
- follow a pattern to create an image
- identify the images they produce

Grouping for Instruction

- Whole group for introduction, instruction, and closure
- Partners or small group for investigation

Materials and Equipment

- Eight panels
- K'NEX Bricks
- Chart paper
- Markers/Crayons
- Copies of template T-23

NCTM Standards and Expectations Addressed

- Use visualization, spatial reasoning, and geometric modeling to solve problems
 - build and draw geometry objects.
- Analyze characteristics and properties of two- and three-dimensional geometric shapes and develop mathematical arguments about geometric relationships
 - recognize, name, build, draw, compare, and sort two- and three-dimensional shapes;
 - describe attributes and parts of two- and three-dimensional shapes;
 - identify, compare, and analyze attributes of two- and three- dimensional shapes and develop vocabulary to describe the attributes.

Standards are listed with permission of the National Council of Teachers of Mathematics (NCTM). NCTM does not endorse the content or validity of these alignments.

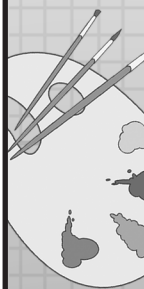

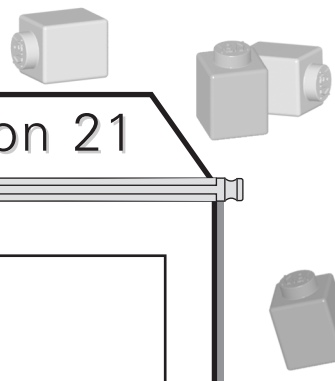

PROCEDURE

- Provide direct instruction related to polygons and their attributes.
- Distribute all necessary materials to students.
- Assign a shape from the list below to each of the groups for building:

rhombus	rectangle
hexagon	triangle
- Have each group show its image to the class.
- Divide the class into two groups, each with one set of four panels.
- Have each group form a circle and place the panels in the center.
- Select a student to choose a panel from the four in the circle.
- Have that child name the shape and pass the shape to the person on their right.
- The next student states an attribute, different name, or real world example of that shape.
 - Someone in the group must keep track of real world examples that are provided as only four will be allowed for each shape.
 - The students continue passing the shape until they are stumped.
 - One student will keep track of how many responses their group is able to make for each of the shapes.
- Students will learn from each other's observations and the quality and quantity of responses will improve as the activity continues with additional shapes.
- Have students make templates (T-23) of their shapes that can be taped to chart paper for the conclusion of this activity.
- Display the shapes on templates around the classroom on chart paper.
 - Below each template set up three columns headed: Names, Attributes, and Real World Examples.
- Have students work in small groups or with partners to visit each template chart in rotation adding a new name, attribute, or real world example each time they visit a shape.

SUMMARY AND CLOSURE

- Ask students to talk with a partner and write down what they did today in class.
- Ask students to talk with that same partner and to write down what they learned today in class.
- Ask several students to share their responses with the class or with partners.
- Use probing questions to explore students' understanding.

ASSESSMENT

- Observe the students during the activity and use anecdotal note cards to record your observations.
- Have students independently identify names, attributes, and real world examples of polygons.
- Provide materials in a mathematics center that allows students the opportunity to create images of polygons that were not originally included in the activity. The students can then prepare a new template chart for their shape and fill in the appropriate columns.

Lesson Topic: Symmetry**Grade:** 1-3 **Lesson Length:** 40 minutes**Student Objectives**

Students will:

- identify objects around the classroom or in nature that contain lines of symmetry
- complete symmetrical shapes when presented with one-half of the shape
- design and build symmetrical shapes or challenges for classmates

Grouping for Instruction

- Whole group for introduction, instruction, and closure
- Partners or small group for investigation

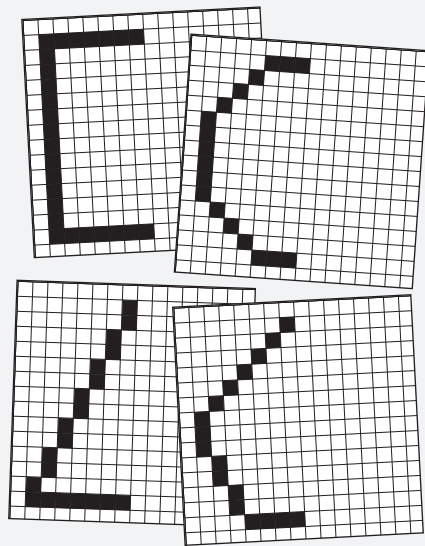
**Materials and Equipment**

- Eight panels
- Green K'NEX Bricks (additional colors for some assessment activities)
- Two copies each of templates T-17, T-18, T-19, & T-20
- Paper, Pencils, Rulers

NCTM Standards and Expectations Addressed

- Use visualization, spatial reasoning, and geometric modeling to solve problems
 - build and draw geometry objects.
- Apply transformations and use symmetry to analyze mathematical situations
 - recognize and create shapes that have symmetry;
 - identify and describe line and rotational symmetry in two- and three-dimensional shapes and designs.

Standards are listed with permission of the National Council of Teachers of Mathematics (NCTM). NCTM does not endorse the content or validity of these alignments.

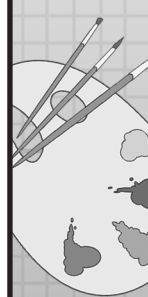

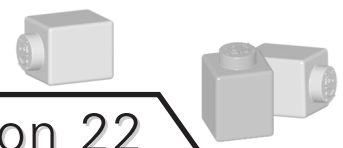

PROCEDURE

- Divide the class into partners or small groups.
- Provide each group with a panel, bricks and one of the templates.
- Instruct students to follow the template to make one-half of a shape.
- Ask students to place their template aside and to make the remainder of the shape.
- Provide rulers for the students and ask them to lay the ruler across their panel to show the location of one line of symmetry for their shape.
- Do any students have a shape that has more than one line of symmetry? Ask them to show their shape to the class and to indicate the lines of symmetry.

SUMMARY AND CLOSURE

- Ask students to talk with a partner and write down what they did today in class.
- Ask students to talk with that same partner and to write down what they learned today in class.
- Ask several students to share their responses with the class or with partners.
- Use probing questions to explore students' understanding.

ASSESSMENT

- Ask students to build a shape on their panel that has two lines of symmetry.
- Ask students to build a shape on their panel that has four lines of symmetry.
- Provide students with teacher prepared templates that have half of a shape or design that is not centered on the template. Ask students to build the entire shape on a panel.
- Ask students to prepare symmetry templates to challenge their classmates. They can include half images for students to complete or complete images that students must analyze to identify lines of symmetry. Add additional colors to the green K'NEX Bricks to increase the challenge and to further test student understanding of symmetry concepts.

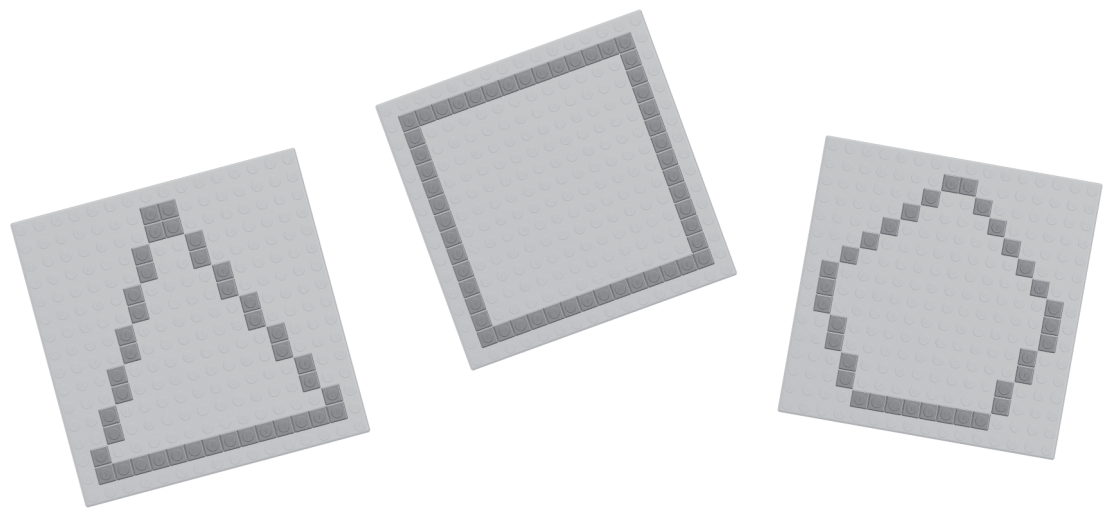

Lesson Topic: Perimeter

Grade: 2

Lesson Length: 40 minutes

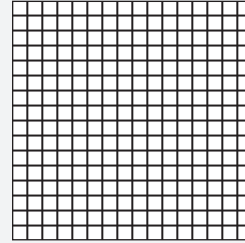

Student Objectives

Students will:

- build a polygon without any diagonal sides
- develop a deeper understanding of perimeter
- explain how to find the perimeter of a polygon
- answer questions pertaining to the polygons that they create

Grouping for Instruction

- Whole group for introduction, instruction, and closure
- Partners or small group for investigation

Materials and Equipment

- Eight panels
- Green K'NEX Bricks
- Paper and pencils
- Copies of template T-23

NCTM Standards and Expectations Addressed

- Understand measurable attributes of objects and the units, systems, and processes of measurement
 - recognize the attributes of length, volume, weight, area, and time;
 - understand how to measure using nonstandard and standard units.
- Apply appropriate techniques, tools, and formulas to determine measurements
 - measure with multiple copies of units of the same size, such as paper clips laid end to end.
- Analyze characteristics and properties of two- and three-dimensional geometric shapes and develop mathematical arguments about geometric relationships
 - recognize, name, build, draw, compare, and sort two- and three-dimensional shapes.

Standards are listed with permission of the National Council of Teachers of Mathematics (NCTM). NCTM does not endorse the content or validity of these alignments.

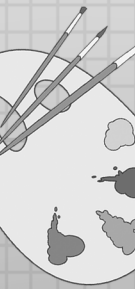

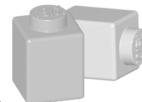
**PROCEDURE**

- Distribute all necessary materials to students.
- Assign each student or group of students to build a polygon on the panel with colored bricks (no diagonal sides).
- Instruct students to determine the perimeter of their polygon.
 - Students may ask for rulers.
 - Suggest that students design a way to measure the panels precisely without using a ruler. (Since all of the bricks are the same size, the width of a brick becomes the unit of measure for this activity. If your students are not familiar with using nonstandard units for measurement, this would be the appropriate time to present the concept to students.)
 - If students experience problems, help them to understand that bricks forming the vertices of their polygon each represent two measurement units.
- After all eight groups have created their polygons and recorded their own perimeters have four of the groups sit at different places around the room with their panels.
- Have the other four groups pair up with one of the sitting groups and switch panels to determine the perimeter of the new polygons. Students should record the name of a person in the group, the name of the polygon, and its perimeter.
- Have students rotate through the groups and continue to determine the perimeters of at least four polygons and their own.
- Students should make a template of their shape including their name, the name of the shape, and its perimeter on the back.
- Ask students if anyone has found two shapes with the same perimeter. Are both of the shapes the same or are they different? (If none are found, ask students if it is possible to make two shapes that look different but have the same perimeter. Challenge two groups to work together to see if they can form two different shapes with the same perimeter.)

SUMMARY AND CLOSURE

- Ask students to talk with a partner and write down what they did today in class.
- Ask students to talk with that same partner and to write down what they learned today in class.
- Ask several students to share their responses with the class or with partners.

ASSESSMENT

- Observe the students during the activity and use anecdotal note cards to record your observations.
- Give each student a polygon and have them determine the perimeter of that polygon.

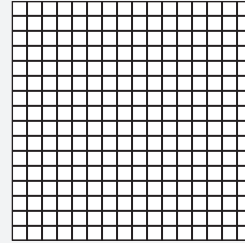
Lesson Topic: Perimeter**Grade:** 2 **Lesson Length:** 40 minutes**Student Objectives**

Students will:

- practice measurement skills
- create polygons to meet specifications (perimeters) provided by the teacher
- demonstrate the ability to measure the perimeter of polygons with nonstandard units
- answer questions pertaining to the polygons that they create

Grouping for Instruction

- Whole group for introduction, instruction, and closure
- Partners or small group for investigation

Materials and Equipment

- Eight panels
- Green K'NEX Bricks
- Copies of template T-23
- Paper and pencil

NCTM Standards and Expectations Addressed

- Understand measurable attributes of objects and the units, systems, and processes of measurement
 - recognize the attributes of length, volume, weight, area, and time;
 - understand how to measure using nonstandard and standard units.
- Apply appropriate techniques, tools, and formulas to determine measurements
 - measure with multiple copies of units of the same size, such as paper clips laid end to end.
- Analyze characteristics and properties of two- and three-dimensional geometric shapes and develop mathematical arguments about geometric relationships
 - recognize, name, build, draw, compare, and sort two- and three-dimensional shapes.

Standards are listed with permission of the National Council of Teachers of Mathematics (NCTM). NCTM does not endorse the content or validity of these alignments.



PROCEDURE

- Distribute all necessary materials to students.
- Inform each small group to build a shape that has a perimeter set by the teacher (even number perimeter). Each group will work with a different perimeter that is unknown to the other groups.
- Remind students that they may not use diagonal sides on their polygons.
- After all eight groups have created their polygons and have recorded their own perimeters, have four of the groups sit at different places around the room with their panel.
- Have the other four groups pair up with one of the sitting groups and switch panels to determine the perimeter of a new polygon. Record their data (name of a group member and the perimeter of their polygon).
- Have students rotate through the groups and continue to determine the perimeters until they have four perimeters plus their own listed on the data recording sheet they have designed.
- Bring the class back together as a group and ask each group to show their panel and to state the perimeter of their shape.
- Have students from the four other groups that looked at that shape indicate if they agree or disagree with the perimeter value that is stated. Disagreements can be settled by the two groups and reported to the class.
- When all perimeters seem to be verified, have each group transfer their images to paper on template T-23. These templates can be used for assessment purposes.

SUMMARY AND CLOSURE

- Ask students to talk with a partner and write down what they did today in class.
- Ask students to talk with that same partner and to write down what they learned today in class.
- Ask several students to share their responses with the class or with partners.
- Use probing questions to explore students' understanding.

ASSESSMENT

- Observe the students during the activity and use anecdotal note cards to record your observations.
- Have each student build a shape with a predetermined perimeter as part of an individual assessment. (Students can submit their answers on T-23 templates.)
- Provide students with a quantity of polygons on panels and/or T-23 templates. Ask them to sequence the polygons from smallest perimeter to largest perimeter.

Lesson Topic: Perimeter

Grade: 2-3 **Lesson Length:** 40 minutes

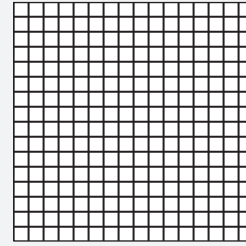

Student Objectives

Students will:

- alter polygons to increase the perimeter or number of sides
- develop a deeper understanding of perimeter
- answer questions pertaining to the polygons that they create
- add or subtract bricks from the panel to match perimeter instructions set by the teacher

Grouping for Instruction

- Whole group for introduction, instruction, and closure
- Partners or small group for investigation

Materials and Equipment

- Eight panels
- K'NEX Bricks
- Copies of template T-23
- Paper and pencil

NCTM Standards and Expectations Addressed

- Understand measurable attributes of objects and the units, systems, and processes of measurement
 - recognize the attributes of length, volume, weight, area, and time;
 - understand how to measure using nonstandard and standard units.
- Apply appropriate techniques, tools, and formulas to determine measurements
 - develop strategies for estimating the perimeters, areas, and volumes of irregular shapes.

Standards are listed with permission of the National Council of Teachers of Mathematics (NCTM). NCTM does not endorse the content or validity of these alignments.

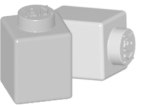
**PROCEDURE**

- Distribute all necessary materials to students. (All are to receive the same number of bricks.)
- Instruct the class to build a polygon that has a perimeter set by the teacher (even number perimeter of 30 or higher). No diagonal sides may be used on the polygons for perimeter activities.
- After all eight groups have created their polygons instruct them to increase the perimeter and/or decrease the perimeter by two, four, six, etc.
- Have students share how they went about completing this task with the entire class. (Did some groups employ the same strategy for all questions? Did some groups have difficulty with the task? Why?)
- Ask students to increase the number of sides on their polygon by two while keeping the perimeter the same.
- Challenge students to build the polygon that has the largest perimeter possible with the pieces they have available. Whose polygon has the greatest number of sides? Solutions to the challenge can be preserved with the use of T-23 templates.

SUMMARY AND CLOSURE

- Ask students to talk with a partner and write down what they did today in class.
- Ask students to talk with that same partner and to write down what they learned today in class.
- Ask several students to share their responses with the class or with partners.
- Use probing questions to explore students' understanding.

ASSESSMENT

- Observe the students during the activity and use anecdotal note cards to record your observations.
- Have each student build a shape with a predetermined perimeter and then ask him or her to increase the perimeter of the shape by some even value. Ask them to increase the number of sides by two or four. Solutions can be submitted on T-23 templates. The original polygon can be indicated with brick locations lightly shaded with pencil. The challenge polygon's brick locations can be shaded with a colorful crayon or marker.

Lesson Topic: Perimeter and Area

Grade: 2-3 **Lesson Length:** 40 minutes

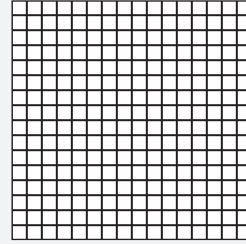

Student Objectives

Students will:

- develop a deeper understanding of perimeter and area
- explain how to measure the area of a polygon
- answer questions pertaining to the polygons that they create
- build shapes with the same perimeter but different areas
- build shapes with the same area but different perimeters

Grouping for Instruction

- Whole group for introduction, instruction, and closure
- Partners or small group for investigation

Materials and Equipment

- Eight panels
- K'NEX Bricks
- Paper and pencil
- Copies of template T-23

NCTM Standards and Expectations Addressed

- Understand measurable attributes of objects and the units, systems, and processes of measurement
 - recognize the attributes of length, volume, weight, area, and time;
 - understand how to measure using nonstandard and standard units;
 - explore what happens to measurements of a two-dimensional shape such as its perimeter and area when the shape is changed in some way.
- Apply appropriate techniques, tools, and formulas to determine measurements
 - use repetition of a single unit to measure something larger than the unit, for instance, measuring the length of the room with a single meterstick.

Standards are listed with permission of the National Council of Teachers of Mathematics (NCTM). NCTM does not endorse the content or validity of these alignments.

PROCEDURE

- Distribute all necessary materials to students.
- Instruct students that they are to create two shapes (either a square and a rectangle or two rectangles) on their panel that have the same perimeter but are different in shape or size. (i.e., Square and rectangle, or a wide and narrow rectangle, etc.)
- Have them copy both shapes on a T-23 template.
- Fill in both shapes on their panels with bricks. How many bricks are there in each of their shapes? (Include the original bricks that outlined their shapes.)
- Introduce the concept of area and how area is a measure of how many square units it would take to cover a shape. Help students to understand that area is characteristic of a shape that can be used as they make comparisons between two or more shapes.
- What are the square units that we use when we determine area using K'NEX Bricks? (The square tops of the bricks.)
- Ask students to refer to their panels and the two shapes that they have filled in. Do the two shapes with the same perimeter have the same area? (If students have made squares and rectangles the answer may be no.)
- Ask students/groups to place a letter on their T-23 template from A to H as you point to them and assign them a letter.
- Place the templates around the classroom on tables or desks.
- Instruct students to move from template to template listing the letter of the template, the perimeter of both shapes, and the area of both shapes.

SUMMARY AND CLOSURE

- Ask students to talk with a partner and write down what they did today in class.
- Ask students to talk with that same partner and to write down what they learned today in class.
- Use probing questions to explore students' understanding of area and perimeter.

ASSESSMENT

- Collect and evaluate student papers from the area and perimeter activity.
- Challenge Activities: Establish an Exploration in Math, Science and Literacy center in the classroom that includes area and perimeter challenges.
 - Build two different shapes that have the same perimeter and the same area. (i.e., rectangle and an irregular, concave polygon ("L" shaped).)
 - Find the perimeter and area of shapes that the teacher has prepared on panels or templates.

Lesson Topic:

Coordinate graphing (mystery picture)

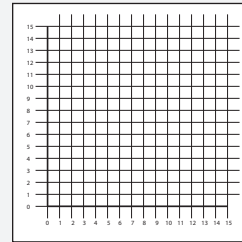
Grade: 3**Lesson Length:** 40 minutes**Student Objectives**

Students will:

- plot sets of ordered pairs to form an image
- organize and list coordinates of an image
- read another student's list of ordered pairs and recreate their image
- develop a deeper understanding of coordinate graphing

Grouping for Instruction

- Whole group for introduction, instruction and closure
- Partners or small group for investigation

Materials and Equipment

- Eight panels
- Collection of K'NEX Bricks
- Copies of template T-21
- Paper, pencils and crayons/markers

NCTM Standards and Expectations Addressed

- Specify locations and describe spatial relationships using coordinate geometry and other representational systems
 - describe location and movement using common language and geometric vocabulary;
 - make and use coordinate systems to specify locations and to describe paths.

Standards are listed with permission of the National Council of Teachers of Mathematics (NCTM). NCTM does not endorse the content or validity of these alignments.

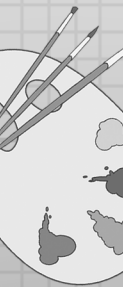

PROCEDURE

- Distribute all necessary materials to students.
- Instruct students to build an image of their own design using K'NEX Bricks.
- Have students place their panel on a T-21 grid so that the pegs are directly above the vertices of the grid. The bottom, left peg on the panel should be directly above the (0, 0) location on the grid.
- Have students transfer the image to a T-21 template using crayons or markers. This will be difficult for students as they are not filling in squares on the grid with color. The students may find it easier to place large colored dots on the template where the grid lines intersect.
- Instruct students to list coordinates of the image on a piece of paper in columns headed by the appropriate brick colors.

Green	Red	Blue
(4,5)	(8,9)	(10,12)
(4,6)	(3,14)	(6,12)
Etc.		

- Have students trade coordinate lists with another group.
- Instruct students to create the image using their classmates' coordinates.
- Have the students who created the template check the completed model for accuracy. The students/groups can work together to address any problems.
- Share the images with the entire class.

SUMMARY AND CLOSURE

- Ask students to talk with a partner and write down what they did today in class.
- Ask students to talk with that same partner and to write down what they learned today in class.
- Ask several students to share their responses with the class or with partners.

ASSESSMENT

- Observe the students during the activity and use anecdotal note cards and/or check lists to record your observations.
- Provide students with a new image on a T-21 template. Challenge them to make the list of coordinates to match the image.
- Provide the students with teacher prepared lists of coordinates and ask the students to create the image that results from that data.

PROCEDURE

- Divide the class into partners or small groups.
- Distribute all necessary materials to students.
- Ask students if they have ever heard of a treasure map. Ask what they know about a treasure map. Help students to realize that a treasure map gives directions. Review the cardinal directions with the students using a compass rose on the board or overhead.
- Instruct students that they are going to follow directions as they follow a path along the pegs on their panel to find an imaginary treasure.
- Follow a set of directions made by the teacher. For example, place your panel on template T-24 (students will not use the data chart along side the template for this activity.) and place a peg at position (D, 3). That is your starting point. Count 8 pegs north and place another peg, move 4 pegs east and place another peg, and so on moving 3 pegs south, and 2 pegs west. Where did you end up? Ans. (F, 8). If students have gotten lost, review the placement of their pegs to see where they have made their error.
- Have the students copy each move and create a path on copies of the template T-24 using a crayon or marker.

SUMMARY AND CLOSURE

- Ask students to talk with a partner and write down what they did today in class.
- Ask students to talk with that same partner and to write down what they learned today in class.
- Ask several students to share their responses with the class or with partners.
- Use probing questions to explore students' understanding of cardinal directions.
- Have students share with the class how they followed cardinal directions.

ASSESSMENT

- Observe the students during the activity and use anecdotal note cards to record your observations.
- Provide students with a starting point and a written set of cardinal directions to follow using their bricks and panels. Students should record their paths on copies of the template T-24.

Lesson Topic: Social Studies/Geography - Cardinal and Intermediate Directions

Grade: 1-2 **Lesson Length:** 30 minutes

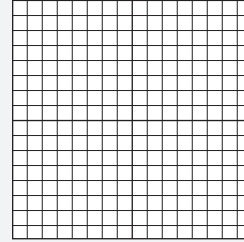

Student Objectives

Students will:

- follow directions to locate points on a plane
- demonstrate their knowledge of cardinal and intermediate directions

Grouping for Instruction

- Whole group for introduction, instruction, and closure
- Partners or small group for investigation

Materials and Equipment

- Eight panels
- K'NEX Bricks
- Copies of Template T-22
- Pencil and paper

NSES Science Content Standards Addressed

- Science as Inquiry
 - Abilities necessary to do scientific inquiry

National Geography Standards Addressed

- The World in Spatial Terms
 - How to use maps and other geographic representations, tools, and technologies to acquire, process, and report information from a spatial perspective

NCTM Standards and Expectations Addressed

- Specify locations and describe spatial relationships using coordinate geometry and other representational systems
 - describe, name, and interpret direction and distance in navigating space and apply ideas about direction and distance.
- Formulate questions that can be addressed with data and collect, organize, and display relevant data to answer them
 - represent data using concrete objects, pictures, and graphs.

Standards are listed with permission of the National Council of Teachers of Mathematics (NCTM). NCTM does not endorse the content or validity of these alignments.

**PROCEDURE**

- Divide the class into partners or small groups.
- Distribute all necessary materials to students.
- Instruct students that they are going to follow directions to locate positions on their panels to find an imaginary treasure much as they have done before but they now are going to add NE, NW, SE and SW to the cardinal directions they used in a previous activity.
- Provide students with copies of template T-22. You will notice that there are heavy lines forming a '+' sign on the template. Instruct students to:
 - Place an 'N' to represent north at the top of the '+' sign on the template. Place the other cardinal directions in their appropriate places.
 - Place the symbol NE at the top right-hand corner of the template.
 - Place the symbol SE at the lower right-hand corner of the template.
 - Place NW and SW in their proper positions.
- Instruct students to place a brick on the peg in the SW corner of their panel. This is their starting point.
- Provide them with the following directions.
 - Move six pegs NE and place a brick in that location.
 - Move four pegs E and place a brick in that location.
 - Move seven pegs N and place a brick in that location.
 - Move six pegs SW and place a brick in that location.
 - Move two pegs W and place a brick in that location. The treasure is here.
- Compare the location of your pegs with those on a classmates' panel. If you disagree, see if you can determine where the error occurred.
- Have the students copy each move and create a path on copies of their template T-22 using a crayon or marker.
- Repeat the activity several times using new directions for practice and to refine skills.

SUMMARY AND CLOSURE

- Ask students to talk with a partner and write down what they did today in class.
- Ask students to talk with that same partner and to write down what they learned today in class.
- Ask several students to share their responses with the class or with partners.
- Use probing questions to explore students' understanding.

ASSESSMENT

- Observe the students during the activity and use anecdotal note cards to record your observations.
- Have students prepare a challenge set of directions for a classmate and a T-22 template with the solution to their challenge. Exchange directions and solve the challenge.

Lesson Topic: Social Studies/Geography - Cardinal and Intermediate Directions

Grade: 2-3 **Lesson Length:** 30 minutes

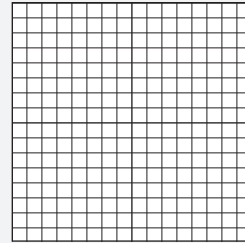

Student Objectives

Students will:

- follow direction to locate points on a plane
- demonstrate their knowledge of cardinal and intermediate directions
- design challenge activities with obstacles for their classmates to navigate through with written directions as they search for a buried treasure

Grouping for Instruction

- Whole group for introduction, instruction, and closure
- Partners or small group for investigation

Materials and Equipment

- Eight panels
- K'NEX Bricks
- Copies of Template T-22
- Crayons or markers and paper

NSES Science Content Standards Addressed

- Science as Inquiry
 - Abilities necessary to do scientific inquiry

National Geography Standards Addressed

- The World in Spatial Terms
 - How to use maps and other geographic representations, tools, and technologies to acquire, process, and report information from a spatial perspective

NCTM Standards and Expectations Addressed

- Specify locations and describe spatial relationships using coordinate geometry and other representational systems
 - describe, name, and interpret direction and distance in navigating space and apply ideas about direction and distance;
 - make and use coordinate systems to specify locations and to describe paths.
- Formulate questions that can be addressed with data and collect, organize, and display relevant data to answer them
 - represent data using concrete objects, pictures, and graphs.

Geography Education Standards Project. 1994. Geography for Life: The National Geography Standards. Washington D.C.: National Geographic Society Committee on Research and Exploration.

Standards are listed with permission of the National Council of Teachers of Mathematics (NCTM). NCTM does not endorse the content or validity of these alignments.

PROCEDURE

- Divide the class into partners or small groups.
- Distribute all necessary materials to students.
- Inform students that they are going to design a challenge activity for one of their classmates to solve. Students will:
 - Use green bricks to form two islands on their panel.
 - Hide a red brick behind, around or near one of the islands to represent the location of a treasure ship.
 - Place a blue brick somewhere else on the panel that will represent the starting point.
 - Prepare a template of your panel that includes the islands and the location of both the red and blue bricks. Students should not let other groups see this template.
 - Write the cardinal and intermediate directional symbols on their template and proceed to write a set of directions on a separate sheet of paper that should lead their classmates along the panel from the blue brick to the treasure ship without crossing an island.
 - Use crayon or marker to layout the solution to their challenge on their copy of T-22.
- Groups trade written directions and their panels with the red brick removed with another group
- Partners or small groups follow directions and plot the points on the panel.
- When finished, the students will place their panel over the solution template to see how close they came to location of the the treasure ship.

SUMMARY AND CLOSURE

- Ask students to talk with a partner and write down what they did today in class.
- Ask students to talk with that same partner and to write down what they learned today in class.
- Ask several students to share their responses with the class or with partners.
- Use probing questions to explore students' understanding.

ASSESSMENT

- Have students staple their written directions to their solution templates. Place their names on the paper along with the names of the students who solved the challenge. Indicate how close the students came to finding the treasure on the first try.
- Repeat the activity with additional obstacles on the panel.