

KNEX®

Imagine • Build • Play®

9+

DOUBLESHOT COASTER™

3.6ft/pi
1.09m

MOTOR
MOTEUR



EN CONTENTS

DOUBLESHOT COASTER™	4
Track Building Tips	21
Tips & Troubleshooting	51
DOUBLEDROP COASTER™	52

ES CONTENIDOS

DOUBLESHOT COASTER™	4
Consejos para armar las pistas	21
Consejos y solución de problemas	51
DOUBLEDROP COASTER™	52

FR CONTENUS

DOUBLESHOT COASTER™	4
Conseils pour le pistes	21
Conseils & Dépannage	51
DOUBLEDROP COASTER™	52

Go to KNEX.COM
for Instruction Updates

Vaya a KNEX.COM para
actualizaciones de instrucción

Va à KNEX.COM
pour des mises à jour
des instructions

IMPORTANT STUFF FOR PARENTS & KIDS

Keep these instructions in a handy location.
They contain important safety information.

Read all warnings and instructions before you start to build
and operate the model.

⚠ WARNING: CHOKING HAZARD - Small parts.
Not for children under 3 years.

CAUTION: Keep hands, face, hair and clothing
away from all moving parts.

CAUTION: Be careful not to tip the model over.
Model should be placed on a flat and hard surface.

- Share the K'NEX experience with your child and make building with K'NEX a family fun adventure.
- Take your time to enjoy the building process. Don't rush!
- While you're building make sure you face your model in the same direction as the pictures show in the instructions.
- Product and colors may vary.

BATTERY INFORMATION

CAUTION:

- Be sure to insert the batteries correctly and always follow the toy and battery manufacturers' instructions.
- Do not mix old and new batteries or alkaline, standard (carbon-zinc) or rechargeable (nickel-cadmium) batteries. Only batteries of the same or equivalent type recommended should be used.
- Always remove weak or dead batteries from the product; do not short-circuit supply terminals.
- Insert batteries with correct polarity (+/-) as shown.

Important Tips

- Alkaline batteries are recommended.
- Rechargeable batteries are not recommended.
- Remove rechargeable batteries from toy before charging; they must be charged only under adult supervision.

- Non-rechargeable batteries must not be recharged.
- Keep components free of dust; do not immerse or use in water.
- Do not dispose of batteries in a fire; they could leak or explode and cause injury.
- Remove all batteries if the toy will not be used for a long period of time.
- Do not put rods smaller than 2 inches in any openings of the motor; they will damage the motor and cannot be removed.
- Help the environment by disposing of your product and packaging responsibly. The wheelie bin symbol indicates that the product and batteries must not be disposed of in the domestic waste as they contain substances which can be damaging to the environment and health. Please use designated collection points or recycling facilities when disposing of the item or batteries.

How to Insert and Remove Batteries

Use a small Phillips head screwdriver to loosen the screw.
Insert 2 fresh AA batteries (LR6) into the compartment
with the correct polarity (+/-) as shown here.

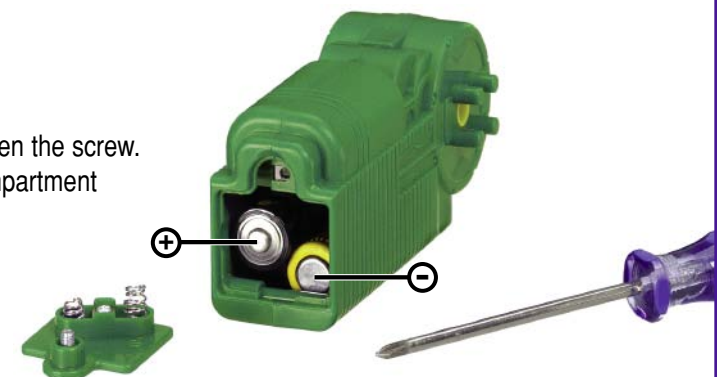

Start Building

To begin your model, find the **1** and follow the numbers. Each piece has its own shape and color. Just look at the pictures, find the pieces in your set that match and then connect them together. Try to face your model in the same direction as the instructions while you build. The arrows show you where the parts connect, but not all connections points have arrows. Faded colors show you this section is already built.

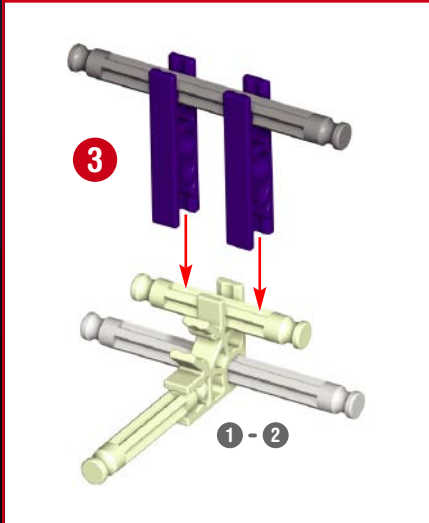
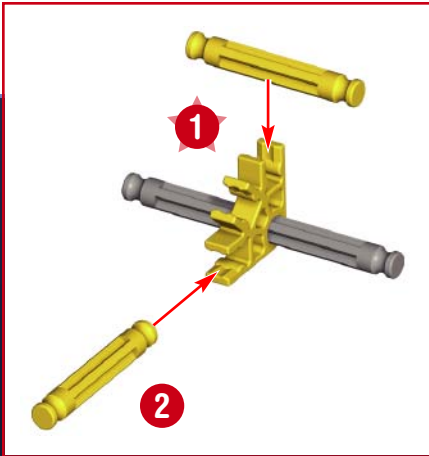

Spacers

There are places in your model where you need to add blue and silver spacers. Be sure to use the right color and count them carefully.



Chain

Be sure to attach all the chain links in the same direction.

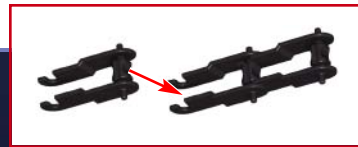

Connectors

There are blue and gray connectors with special long slots. They slide together as you see in the pictures. Push these parts together until you hear a "click."

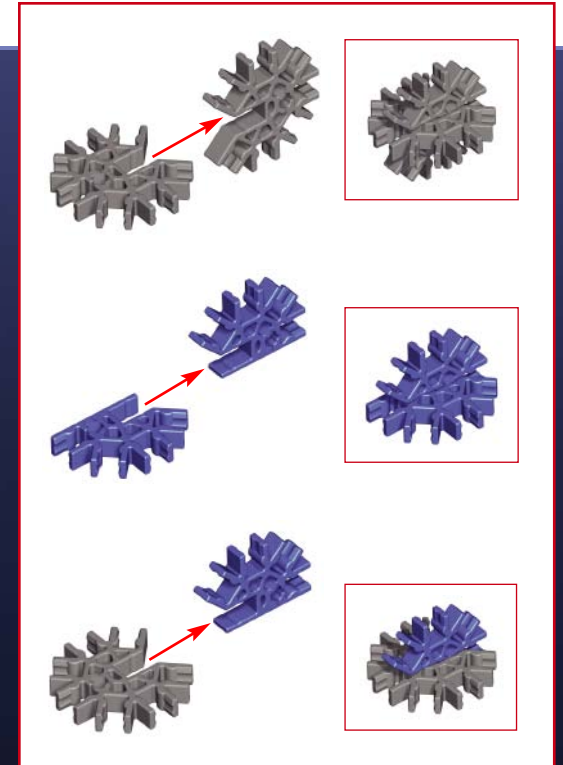

Parts Count

Before you start building, be sure to compare the parts in your set with the parts list here. If anything is missing, call or write to us using the information on the back cover. We are here to help you!

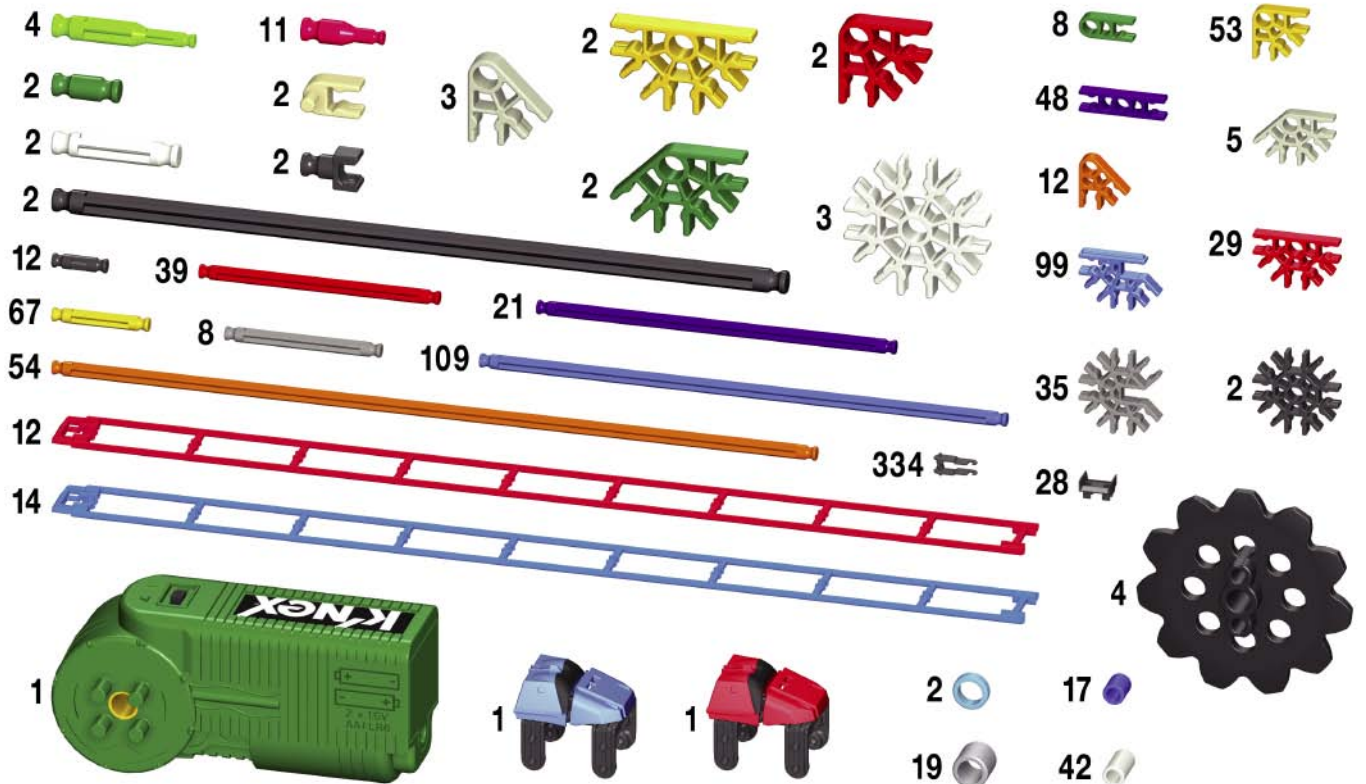

DOUBLESHOT COASTER™

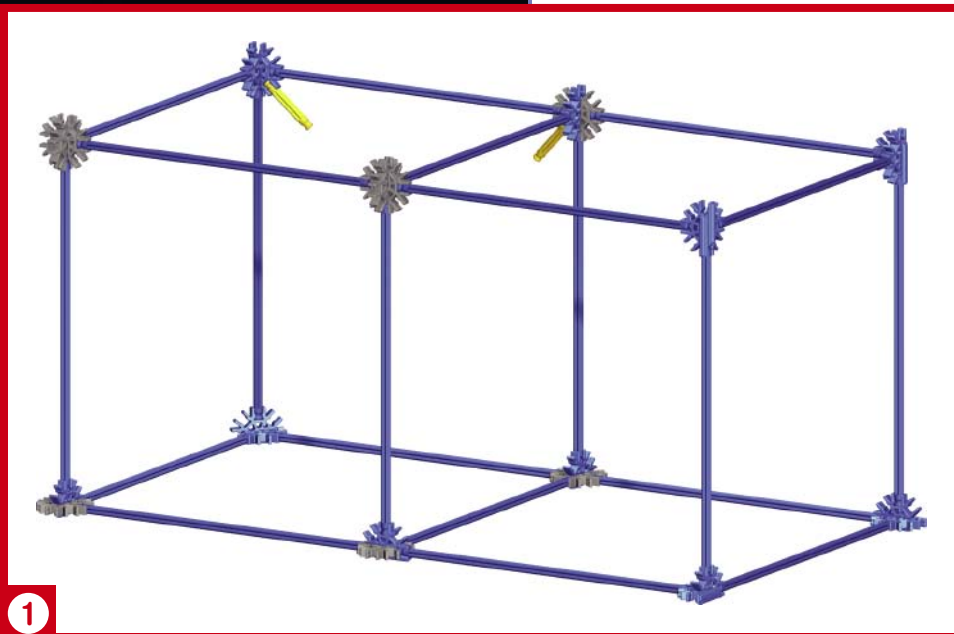
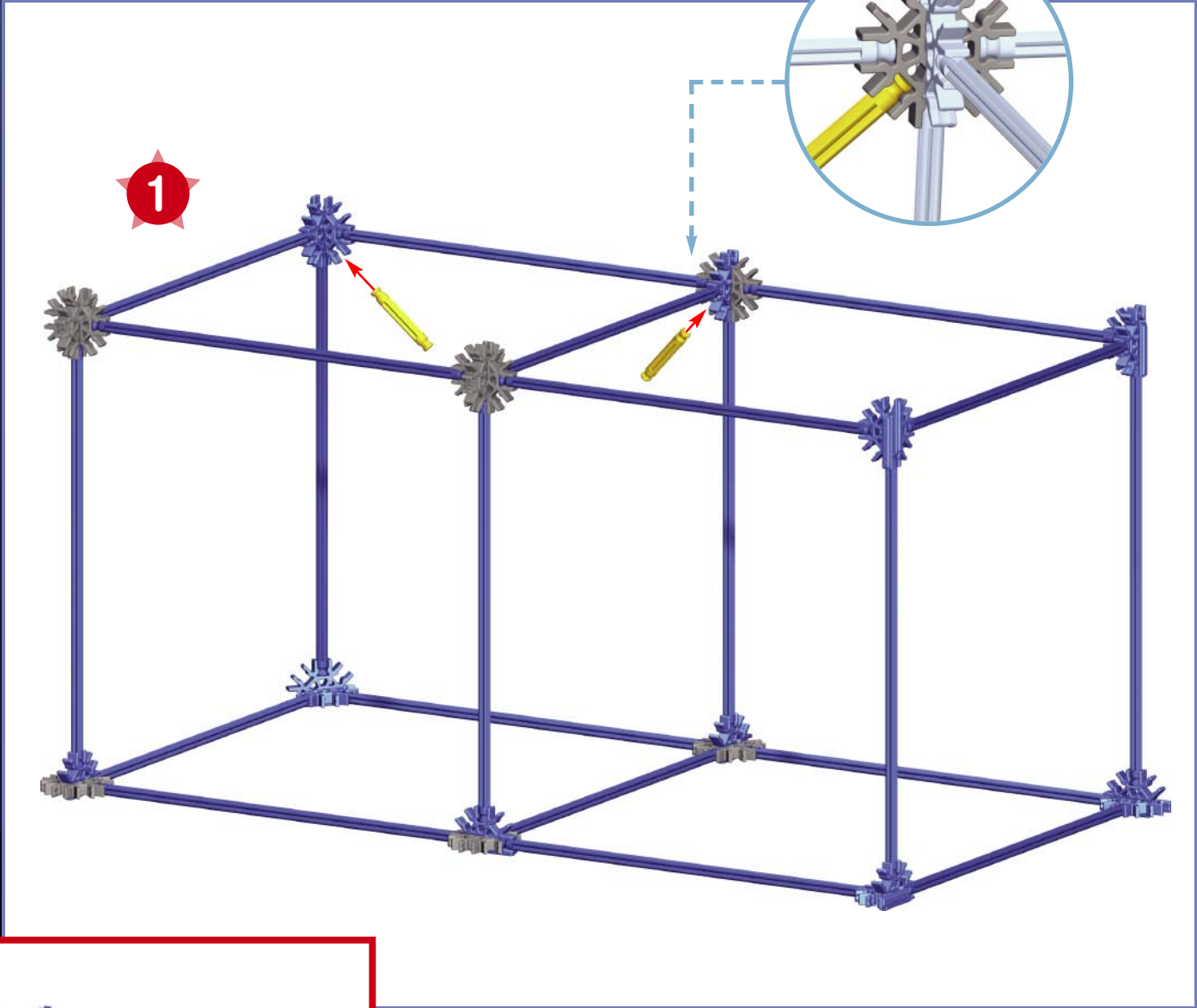
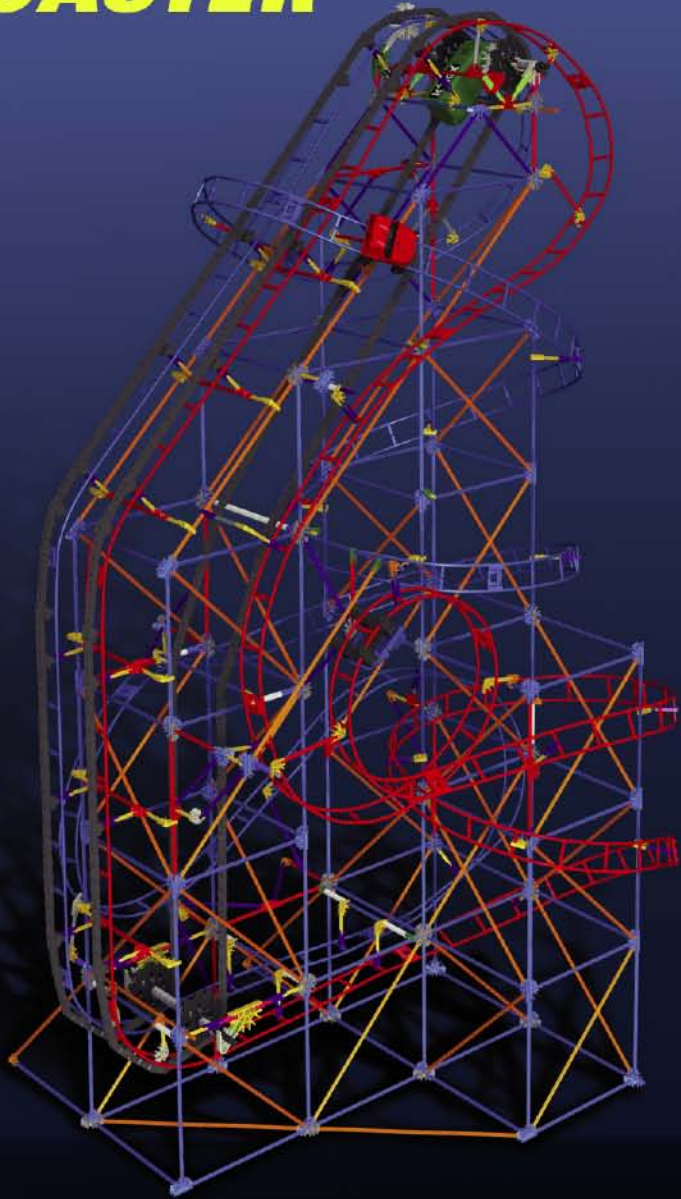

WARNING: CHOKING HAZARD - SMALL PARTS.
Not for children under 3 years.

ADVERTENCIA: PELIGRO DE ASFIXIA - PIEZAS PEQUEÑAS. No para niños menores de 3 años.

AVERTISSEMENT: DANGER D'ÉTOUFFEMENT - Pièces de petite taille. Ne convient pas aux enfants de moins de 3 ans.

WARNHINWEIS: ERSTICKUNGSGEFAHR - KLEINTEILE. Nicht geeignet für Kinder unter 3 Jahren.

AVVERTENZA: PERICOLO DI SOFFOCAMENTO - CONTIENE PICCOLE PARTI. Non adatto per bambini al di sotto di 3 anni.

AVISO: PERIGO DE SUFOCAÇÃO - PEÇAS PEQUENAS. Não se destina a crianças com menos de 3 anos de idade.

WAARSCHUWING: VERSTIKKINGSGEVAAR - KLEINE ONDERDELEN. Niet geschikt voor kinderen onder 3.

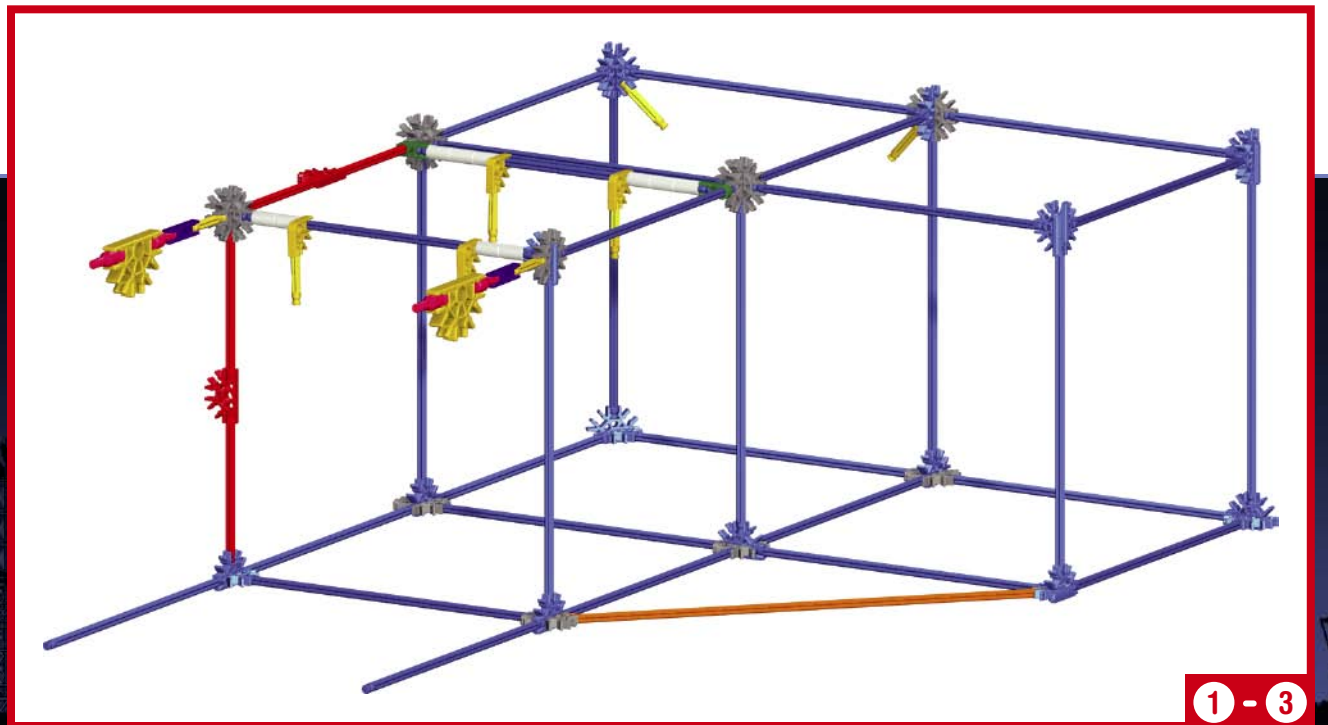
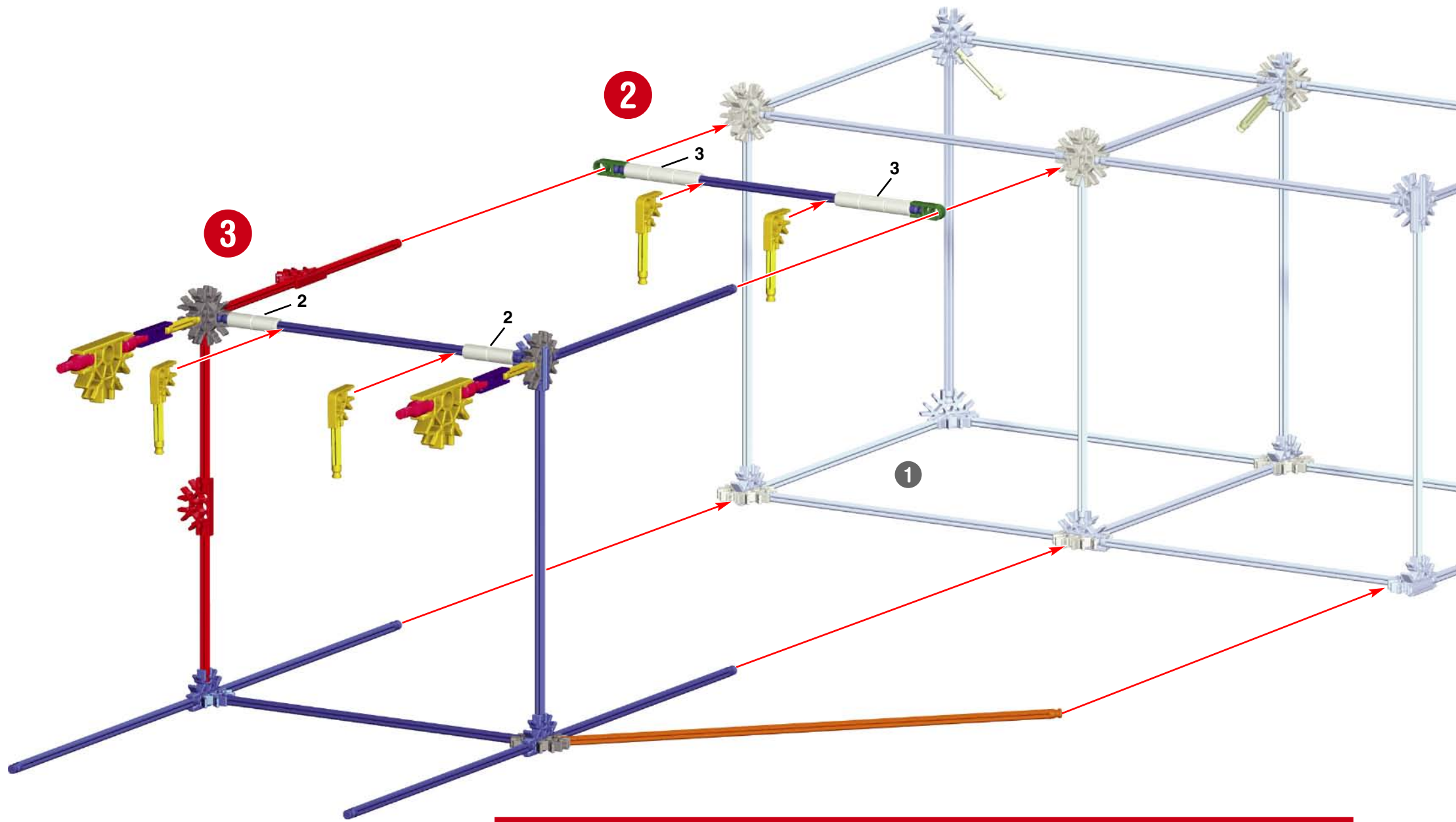

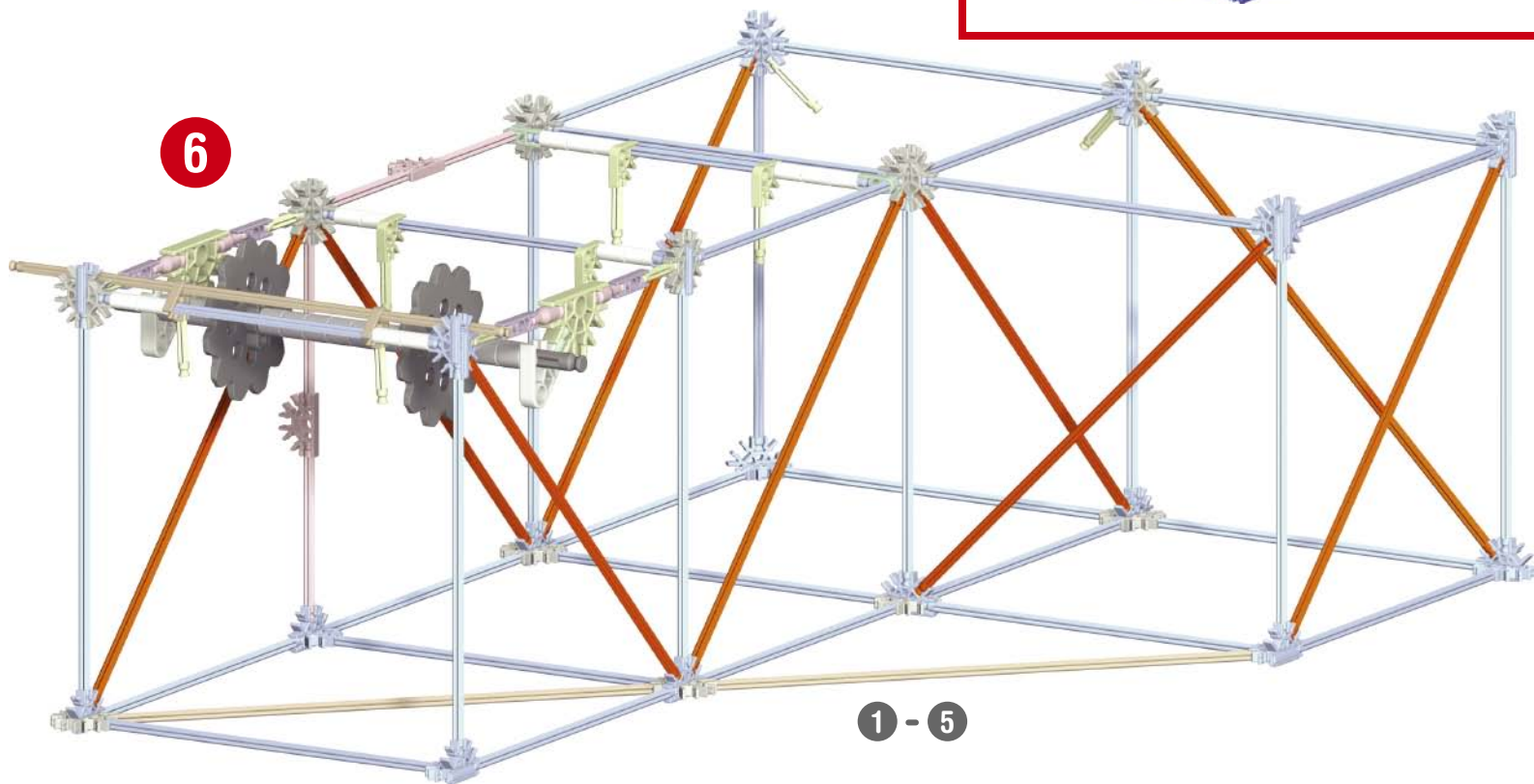
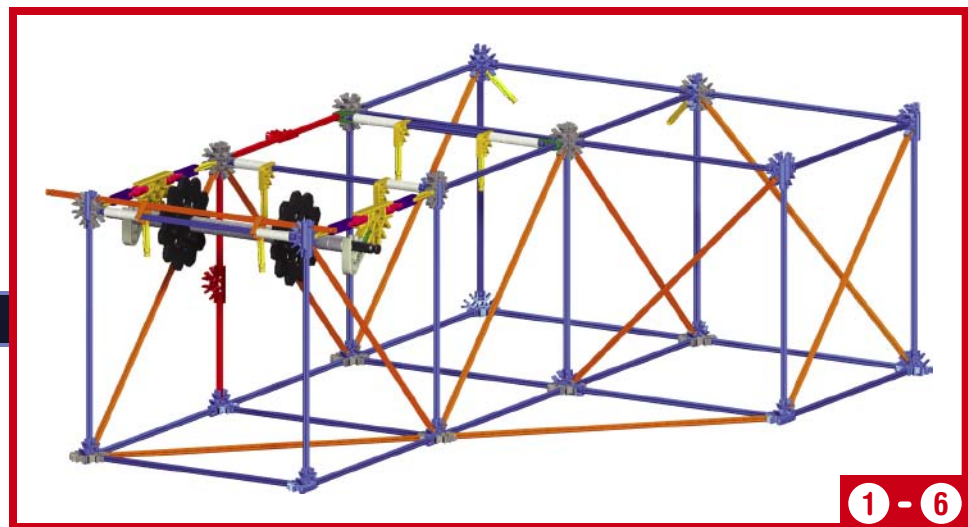
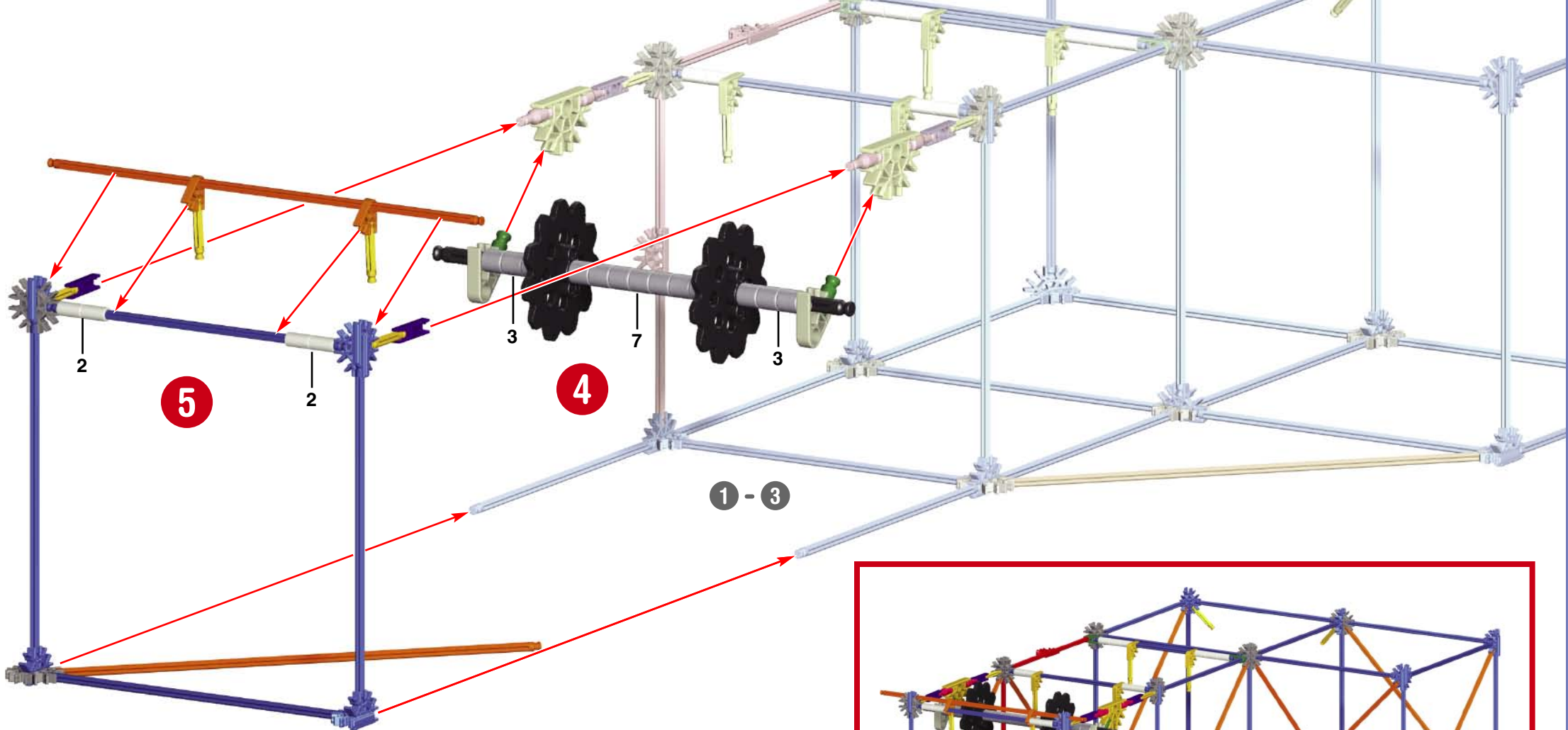

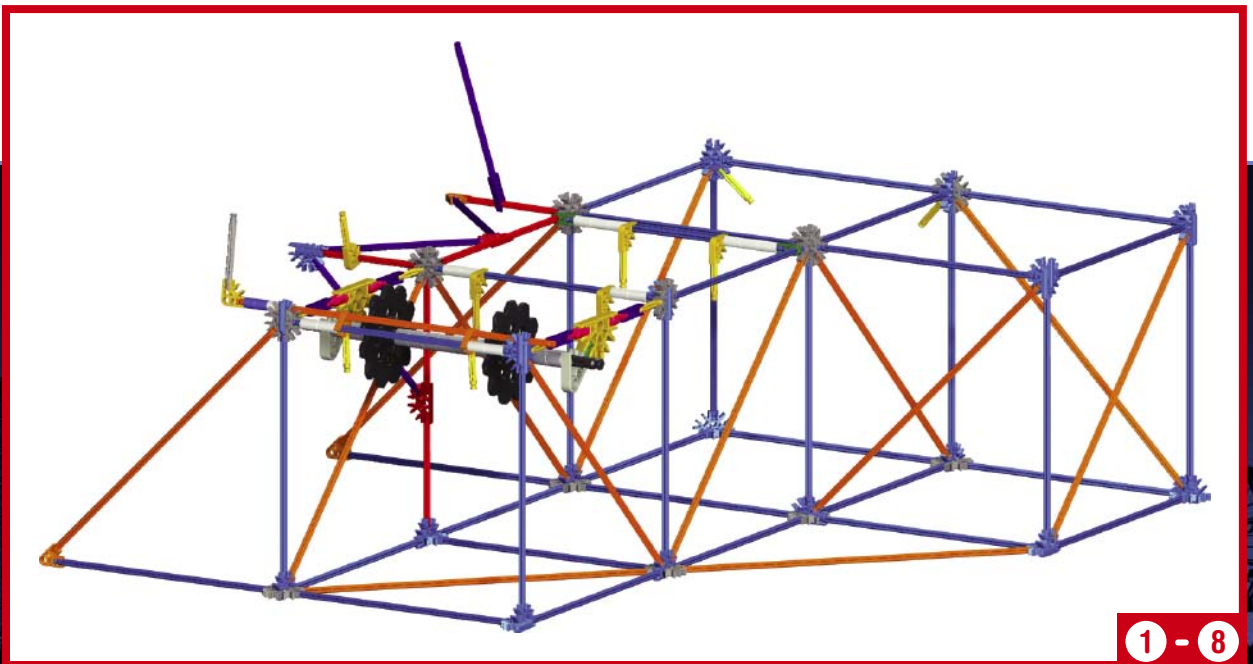
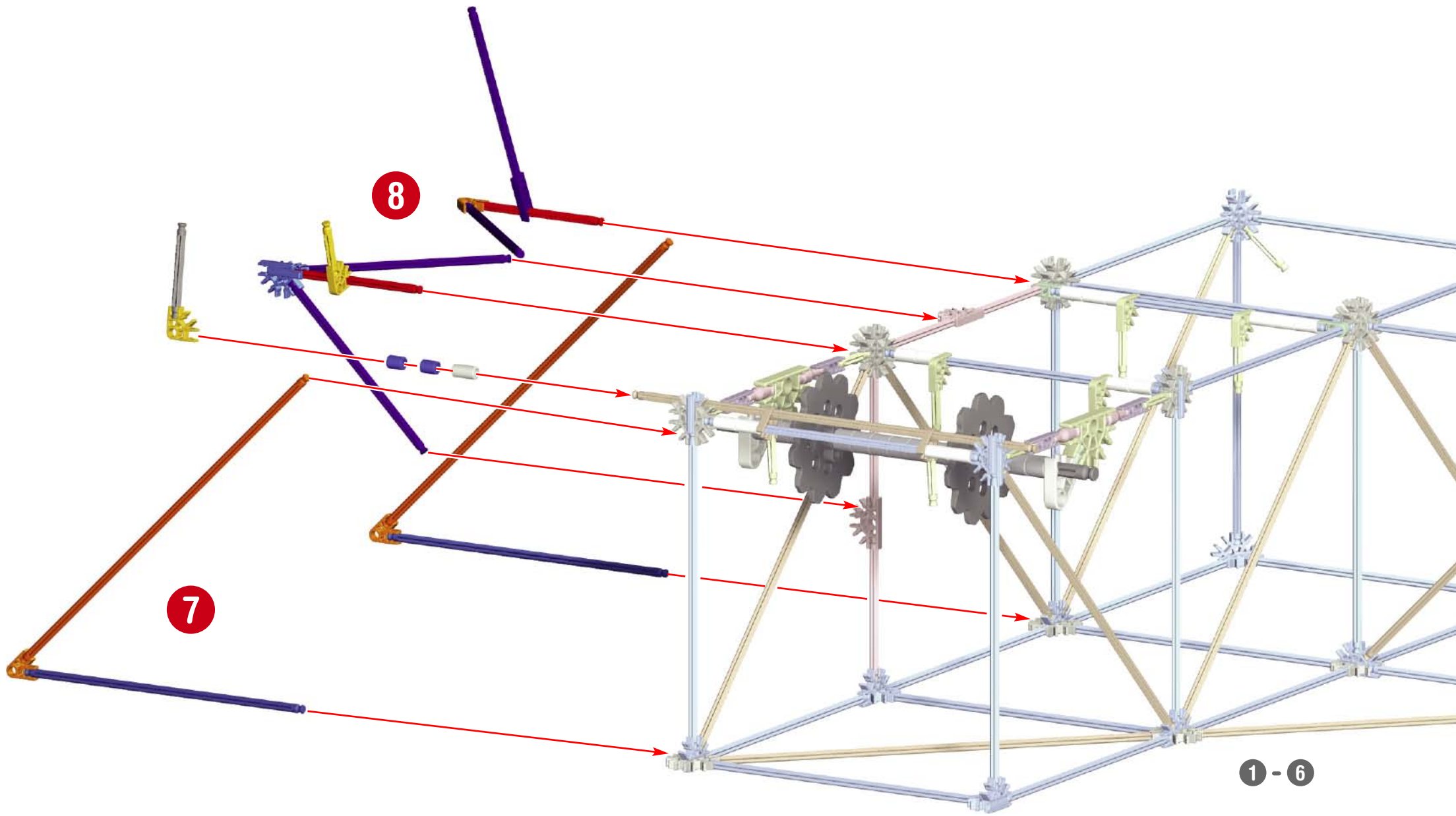

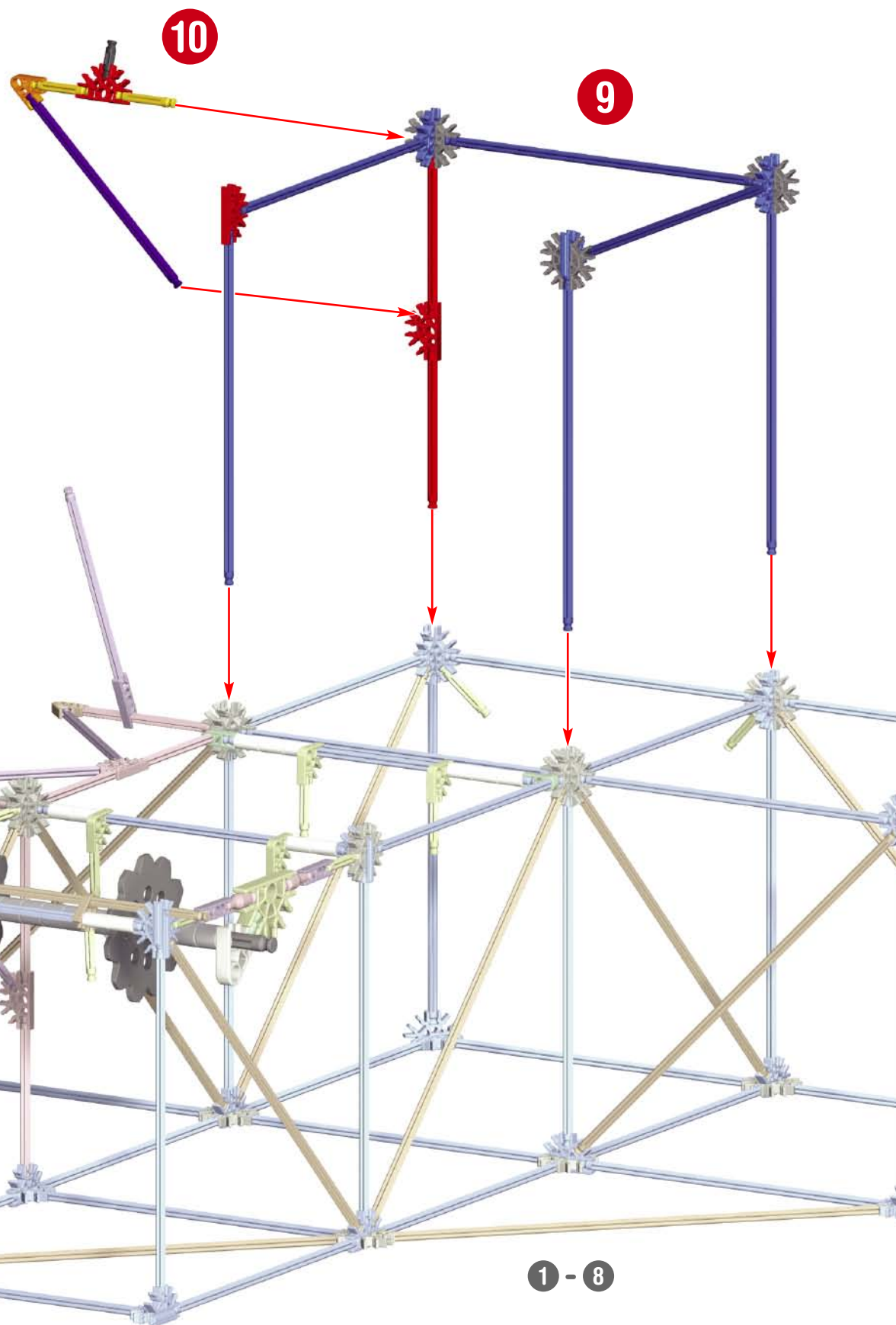
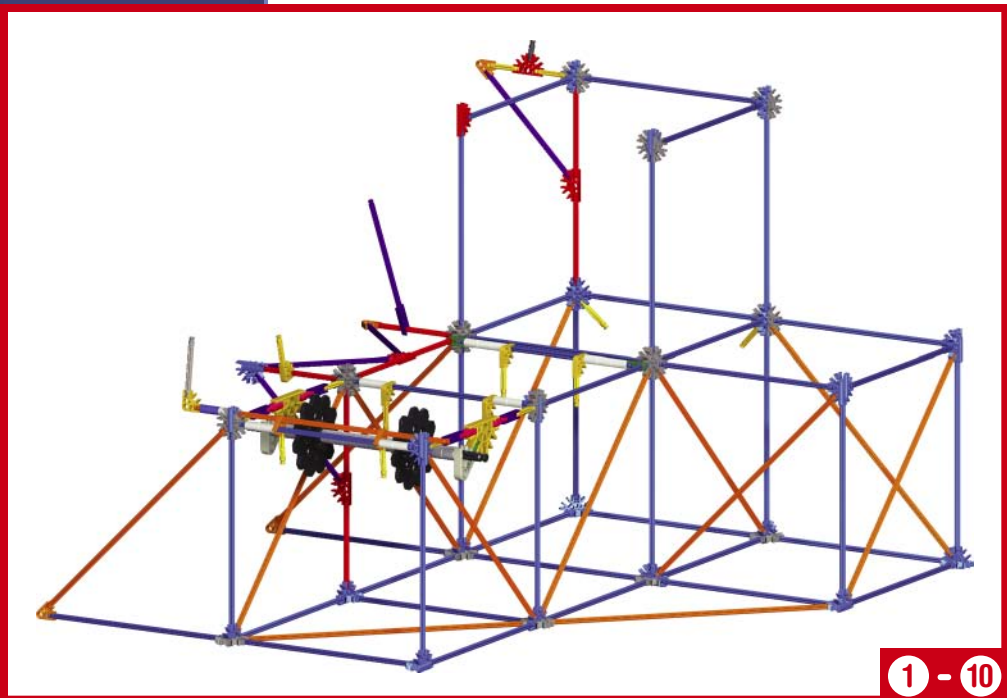

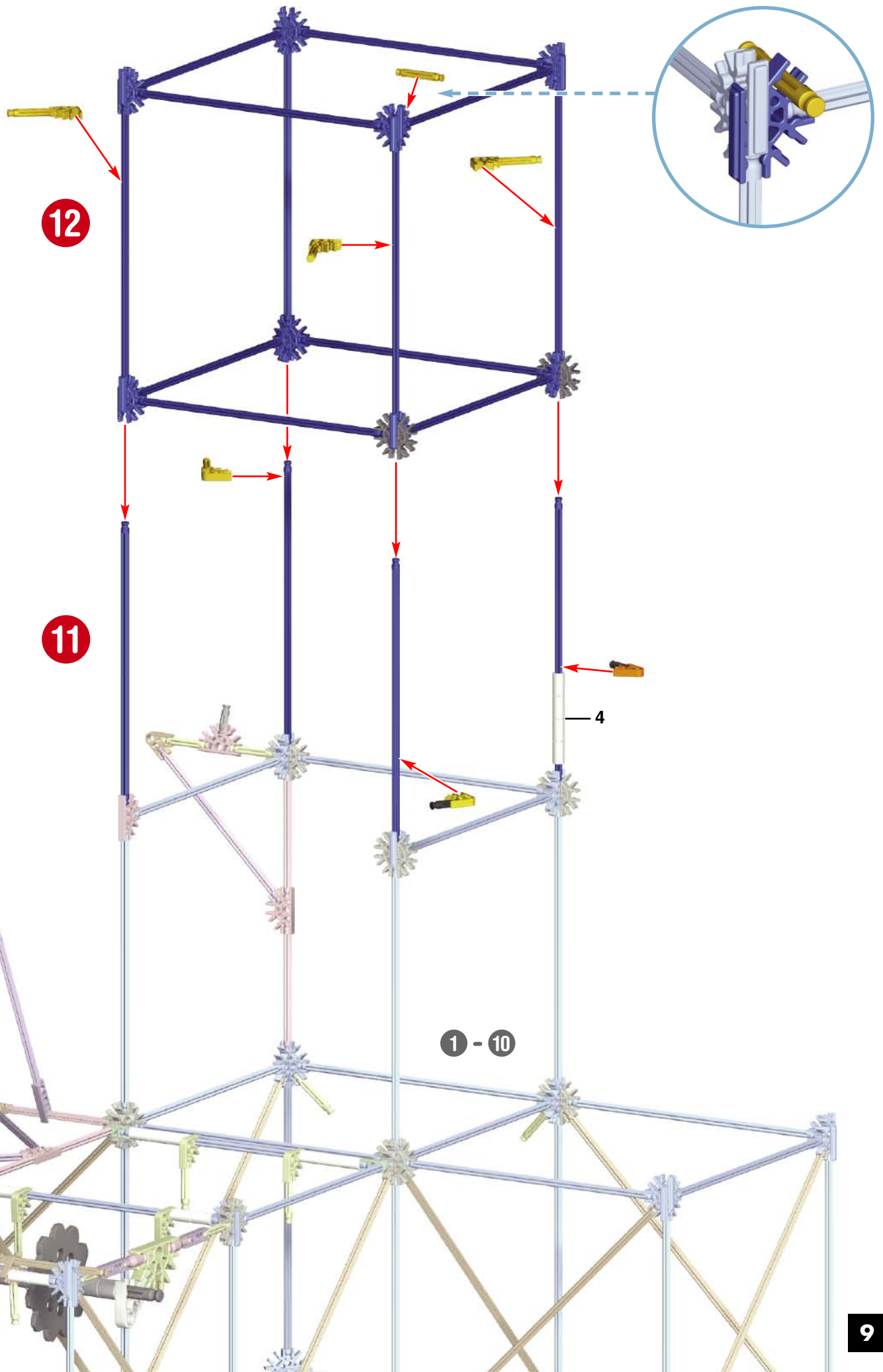
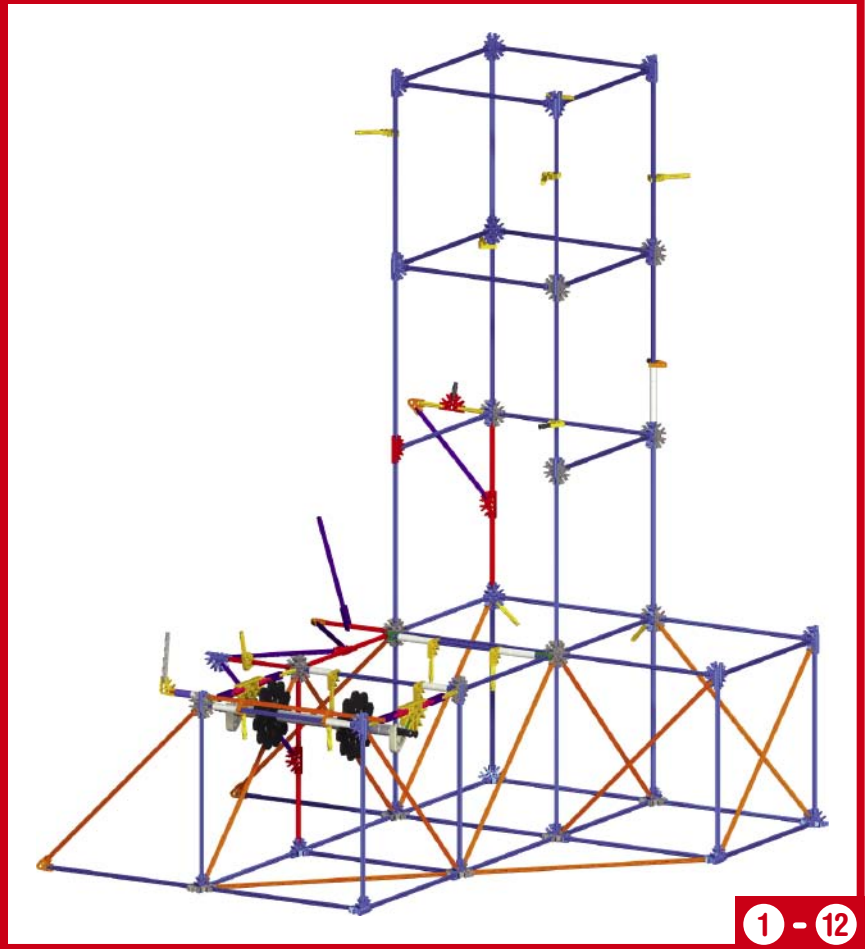

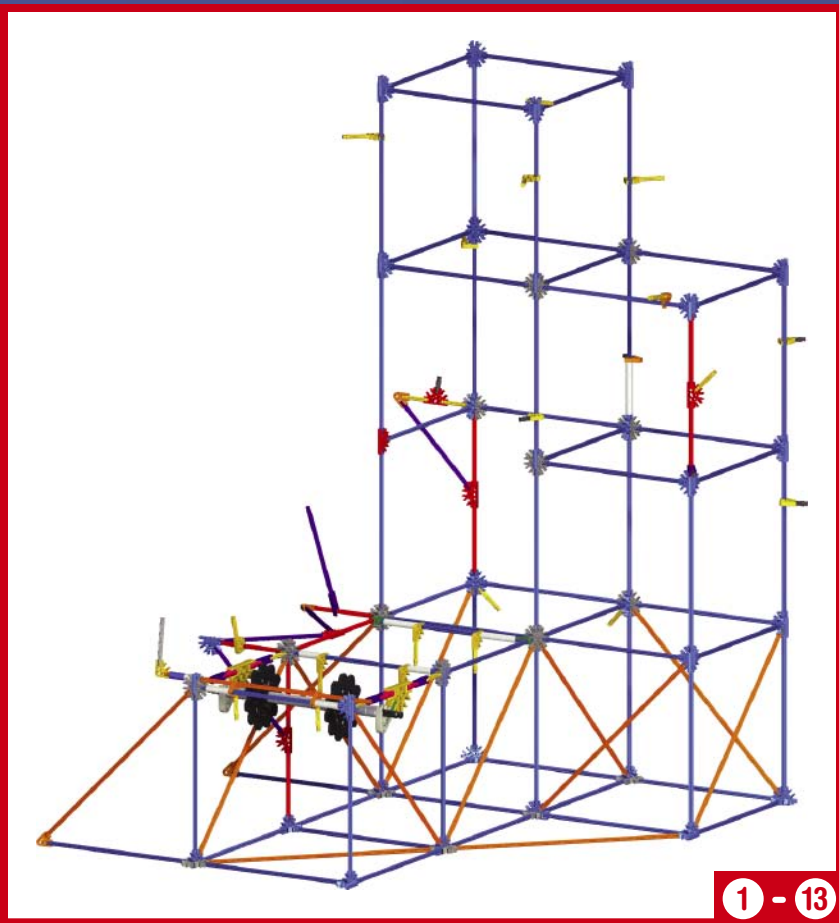

1 - 13

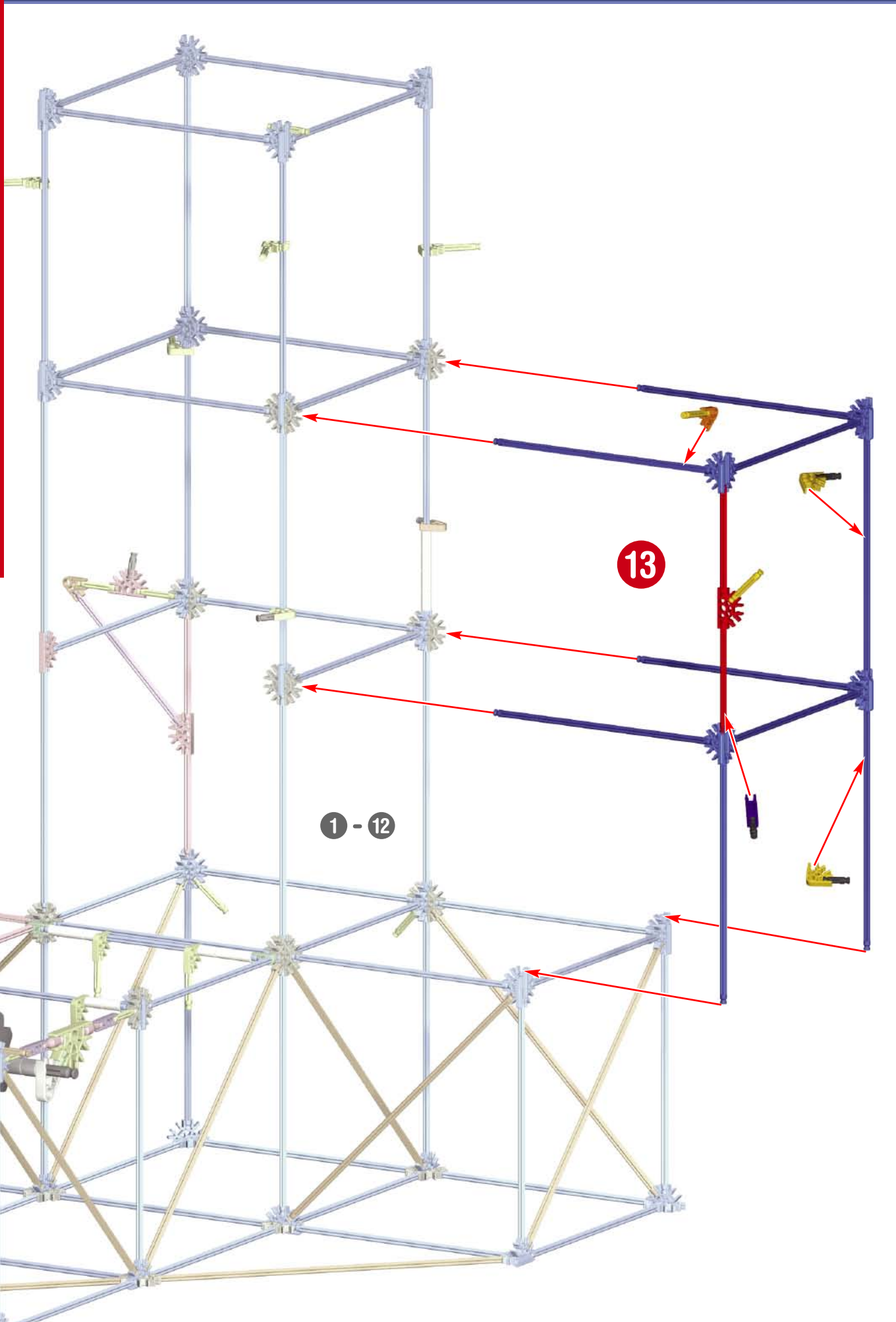

13

1 - 12

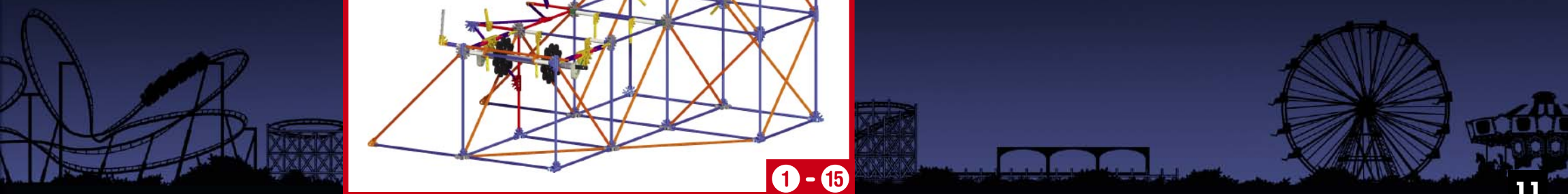
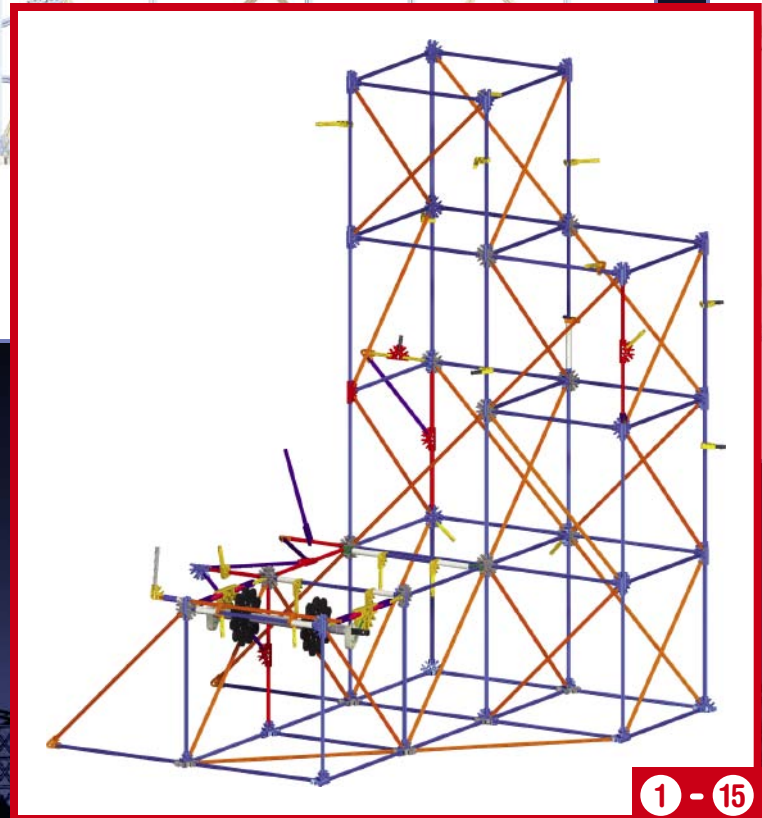
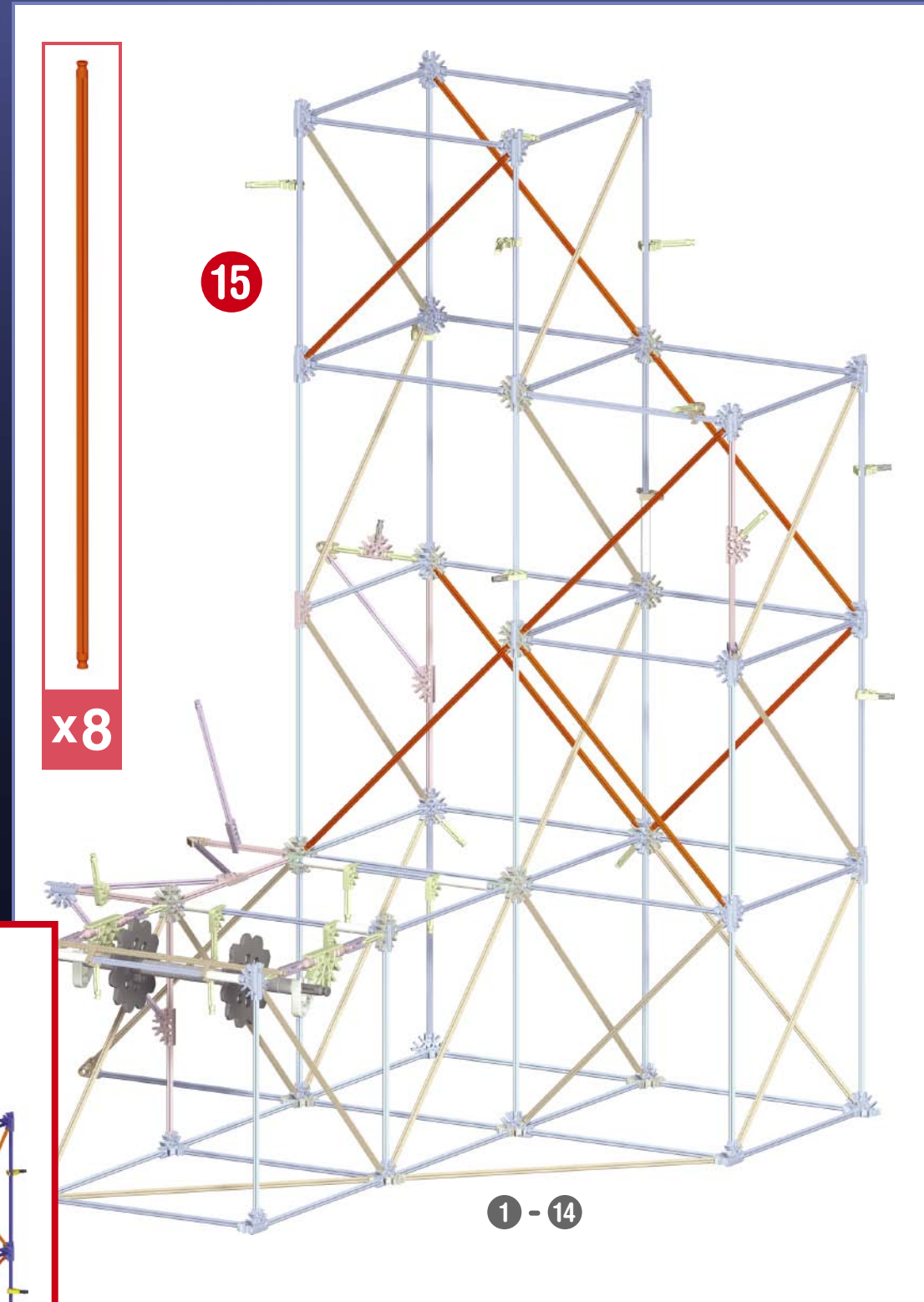
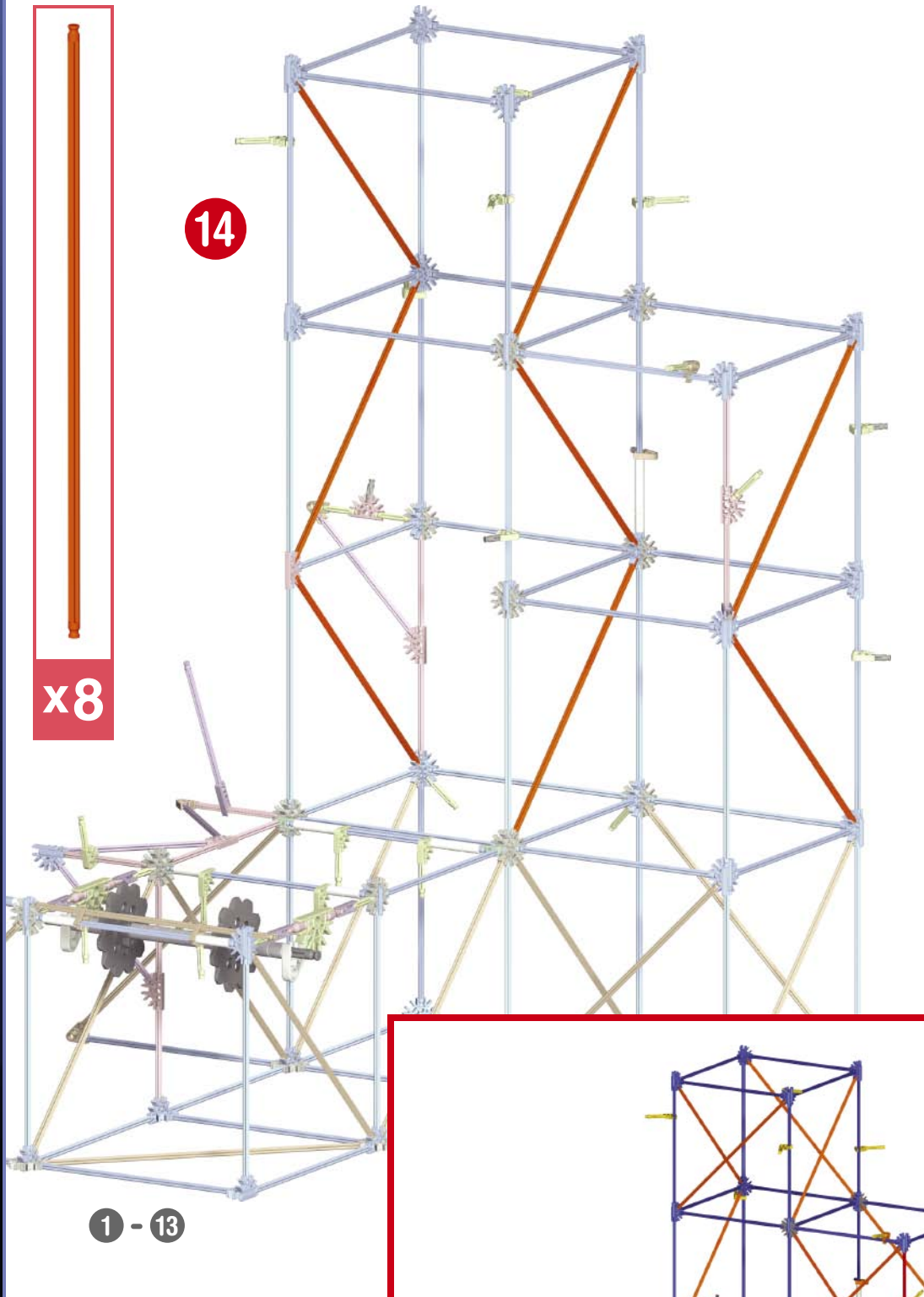

16

17

1 - 15

1 - 17

12

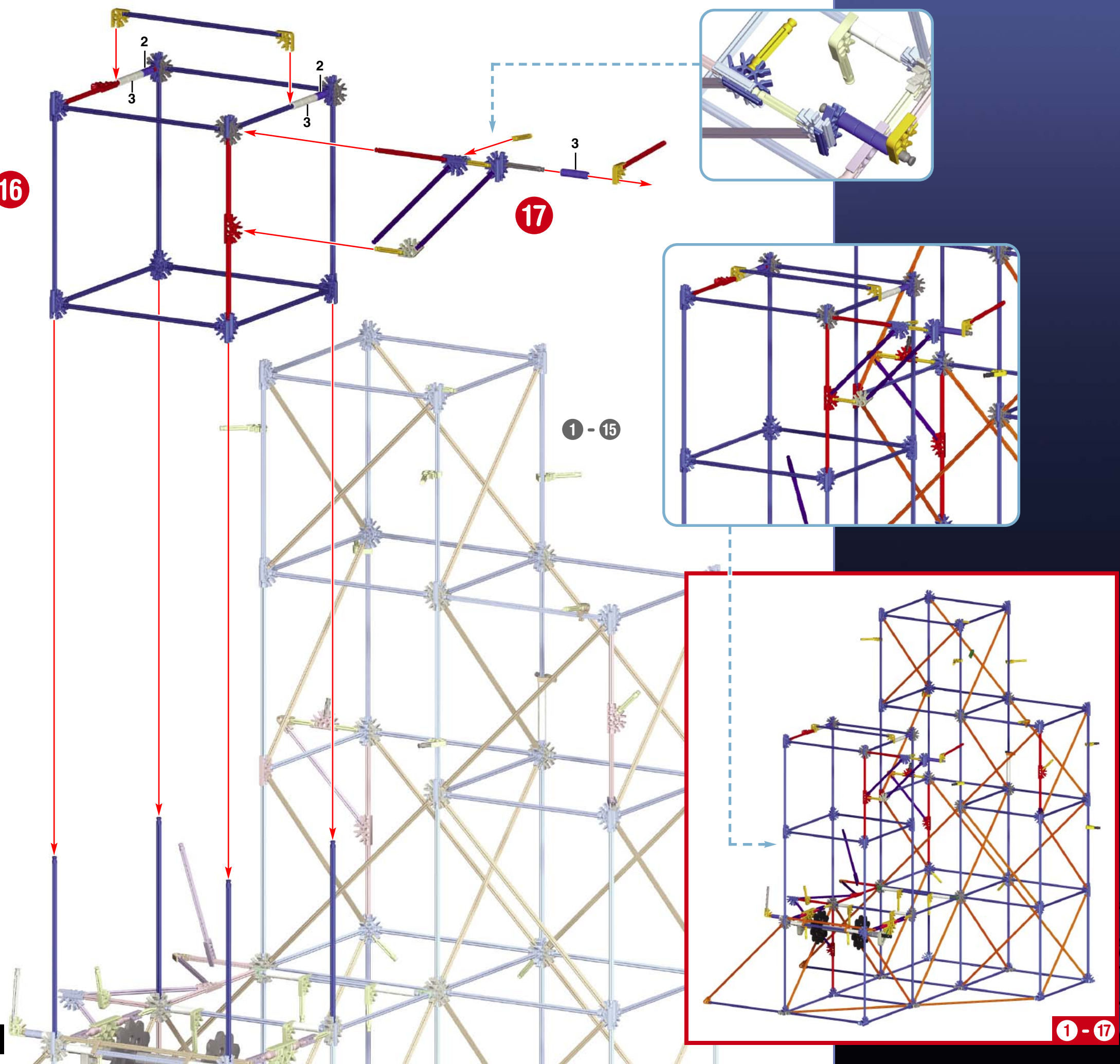

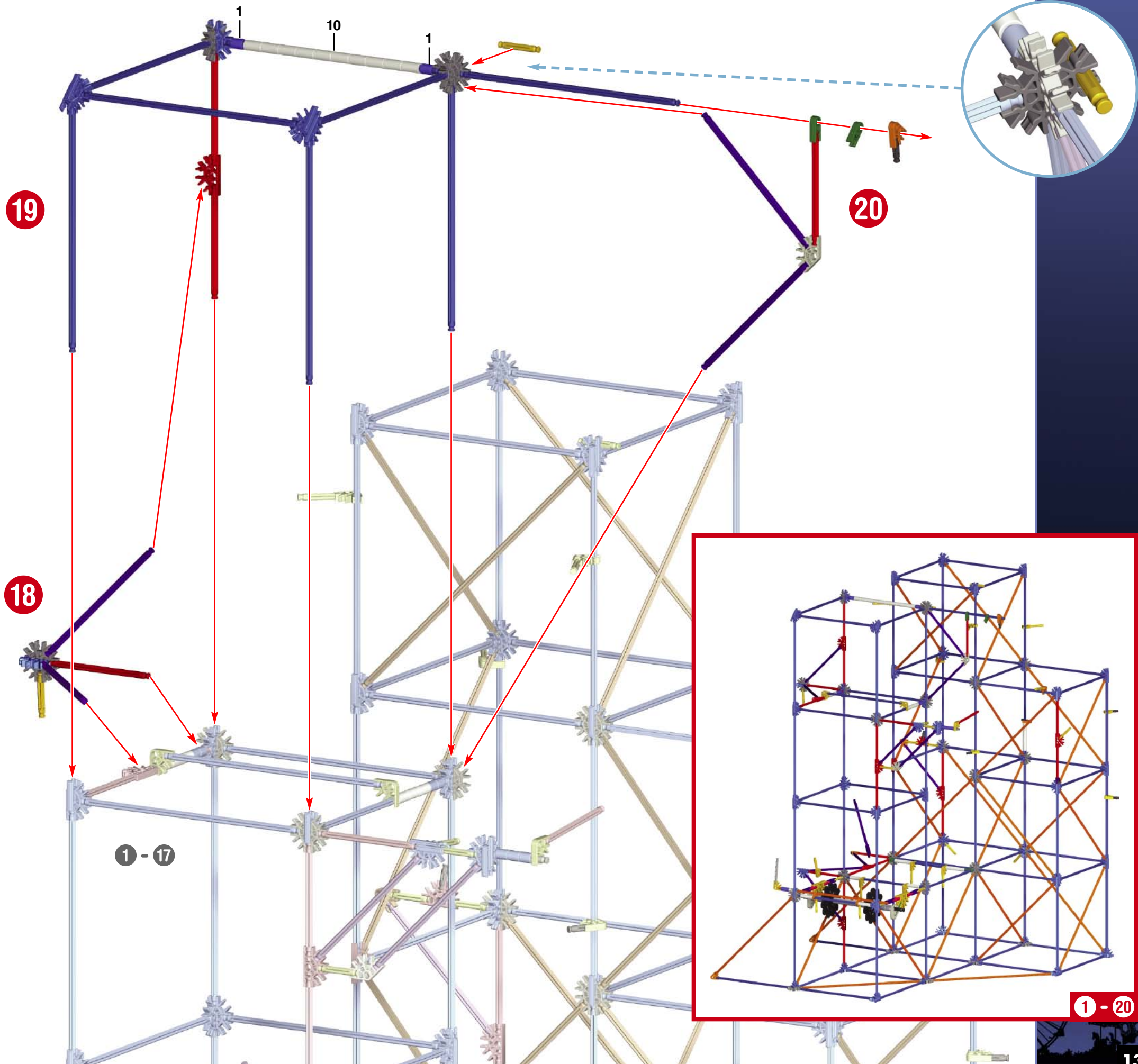

21

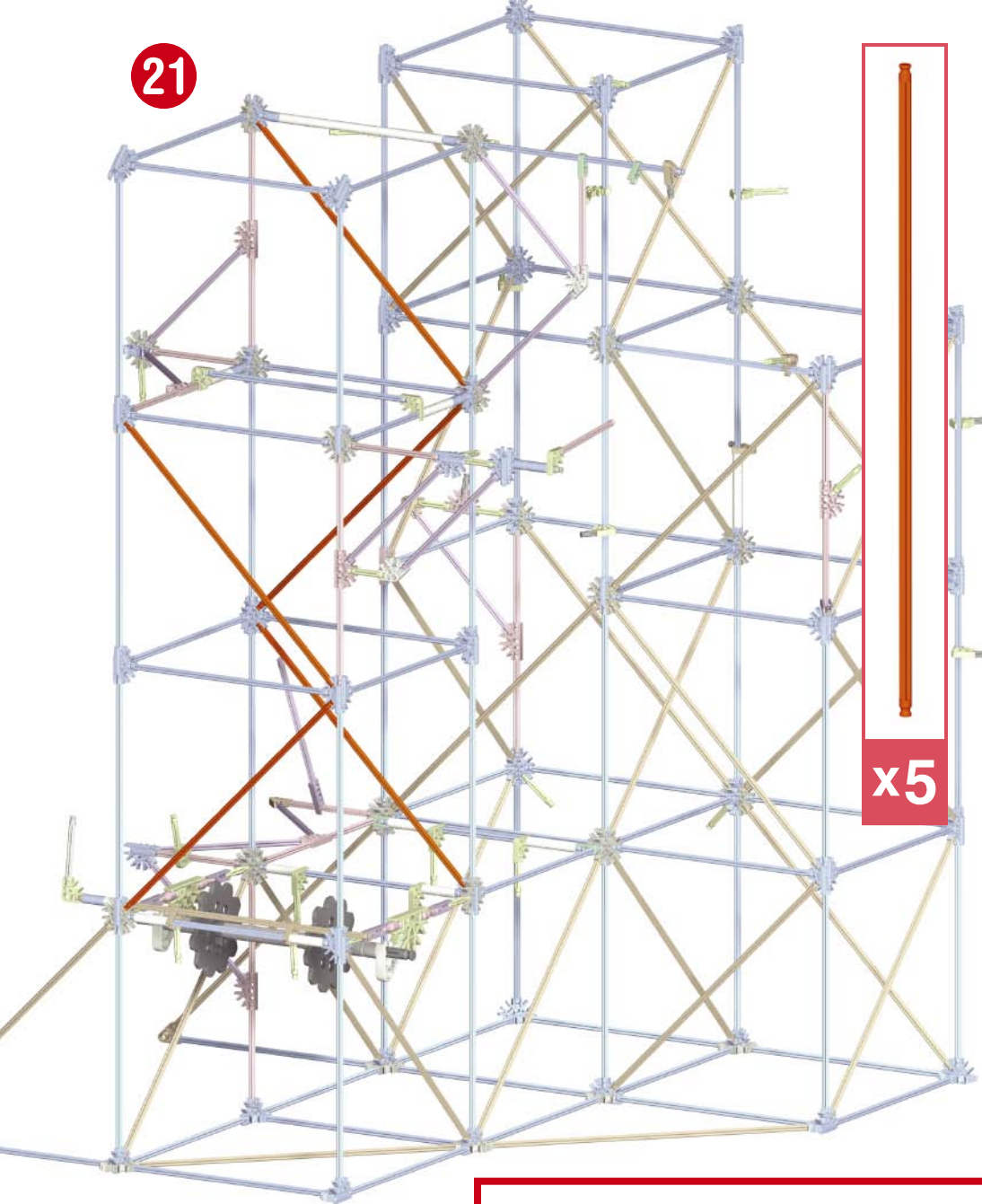

1 - 20

22

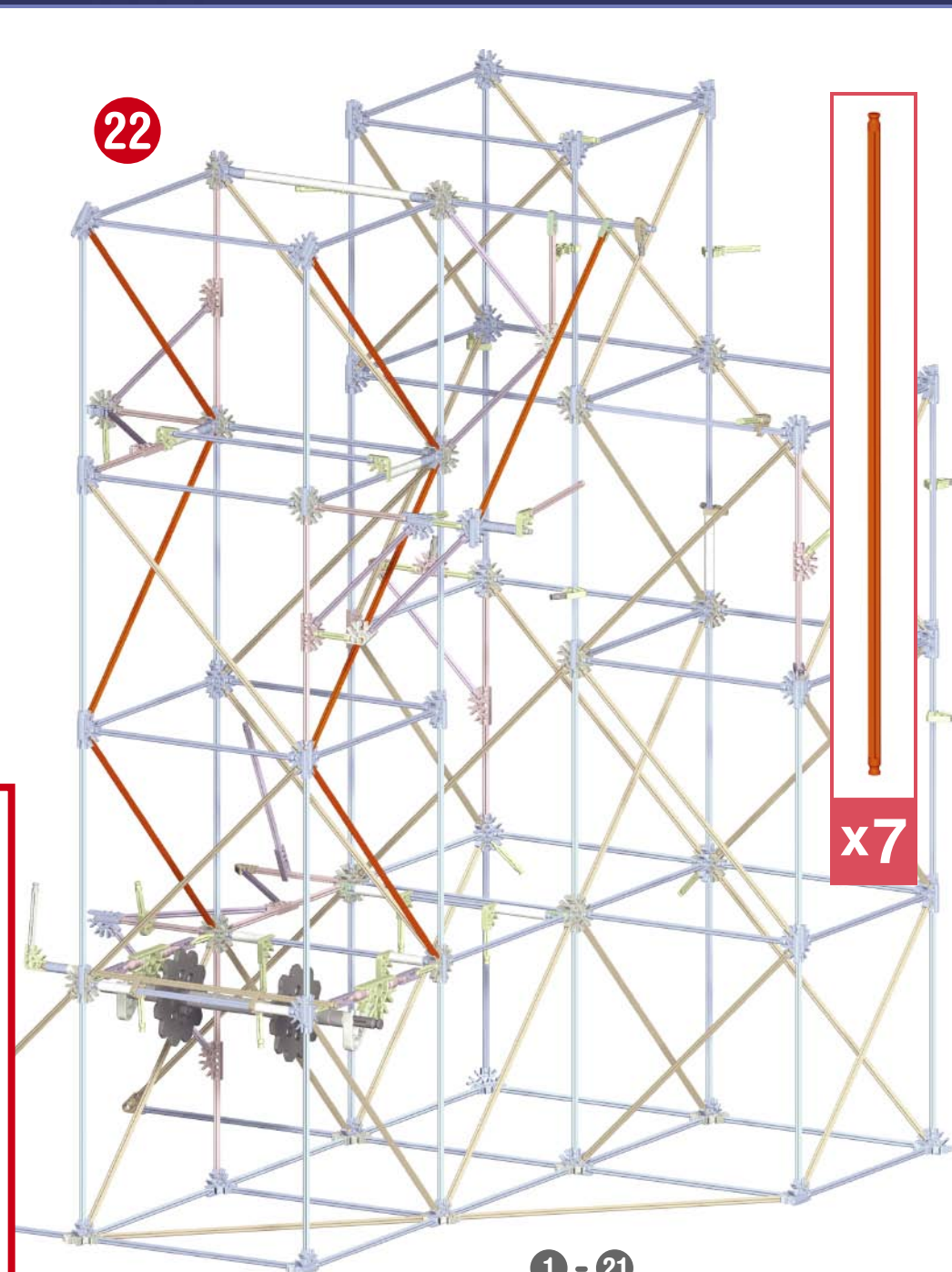

1 - 21

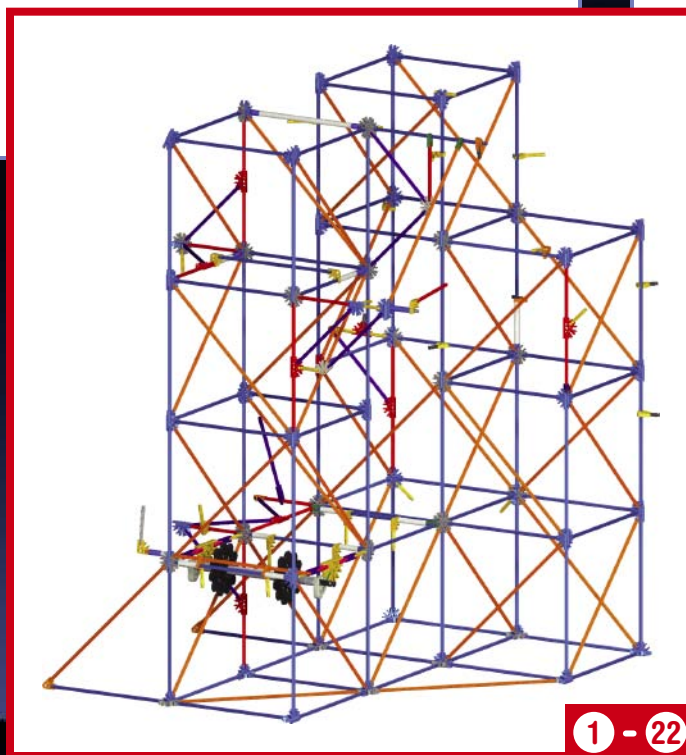

1 - 22

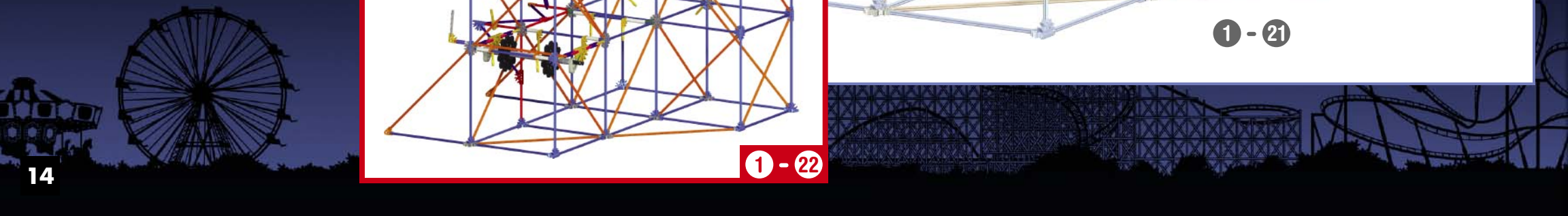

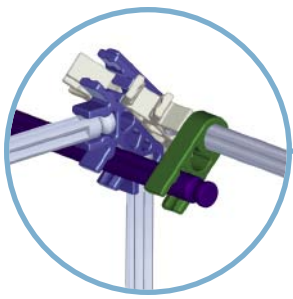

23

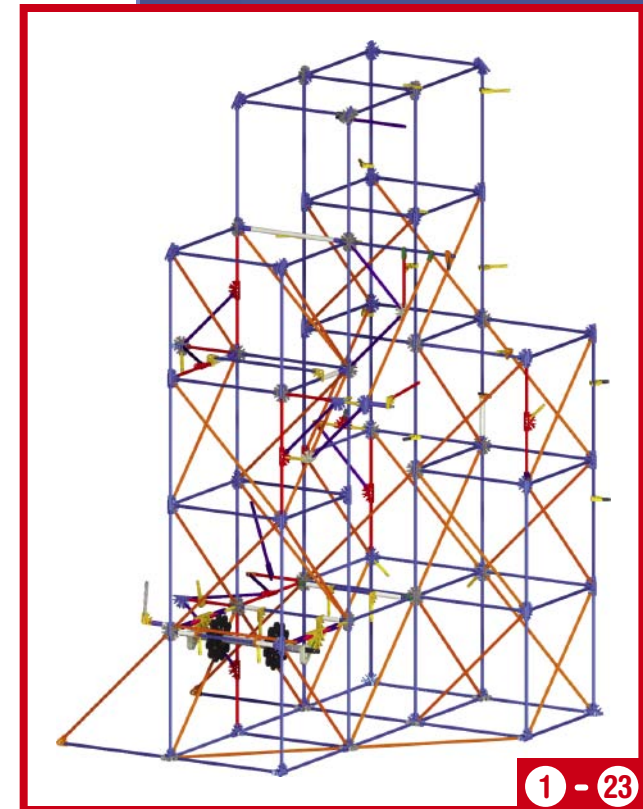
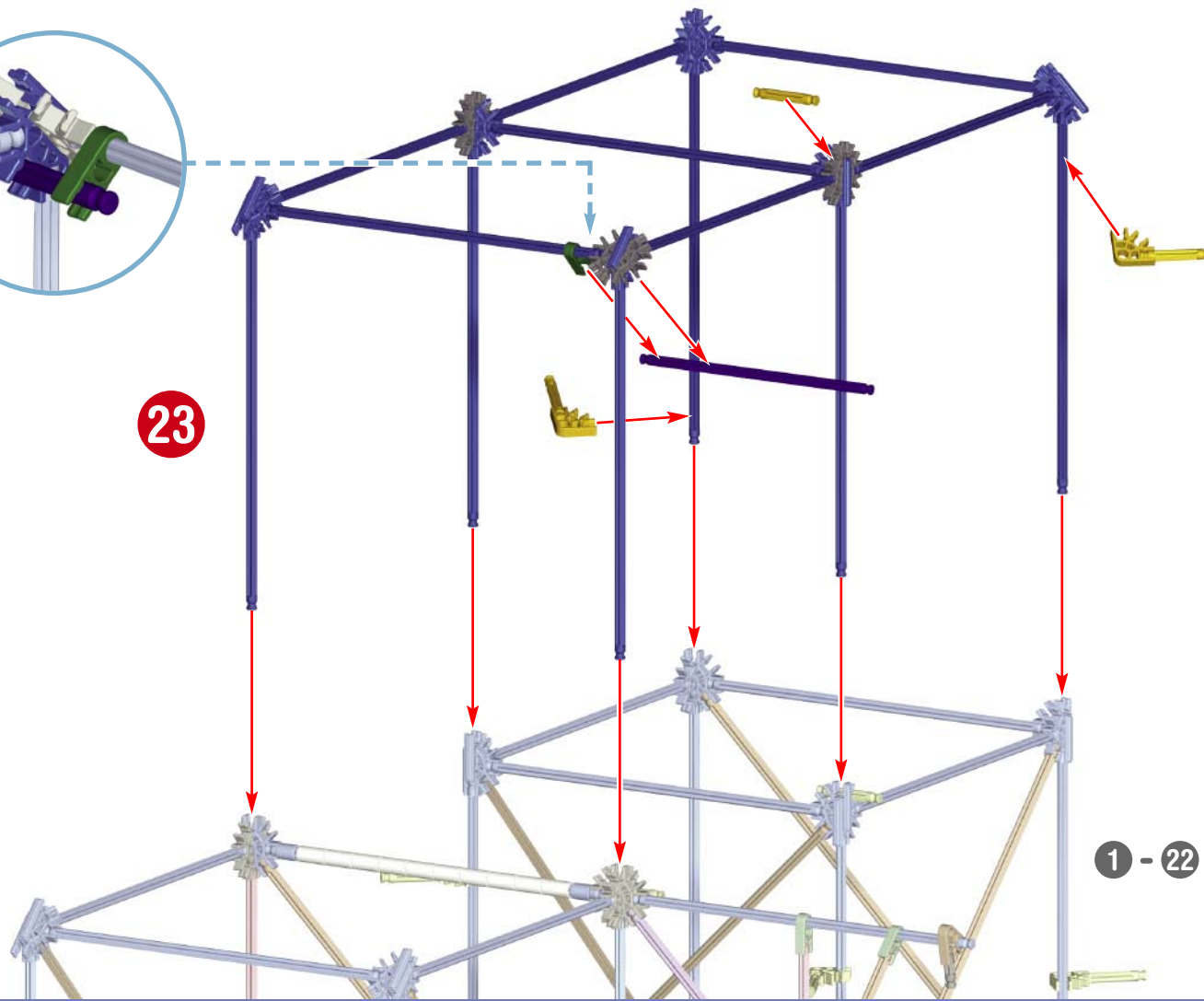

1 - 23

24

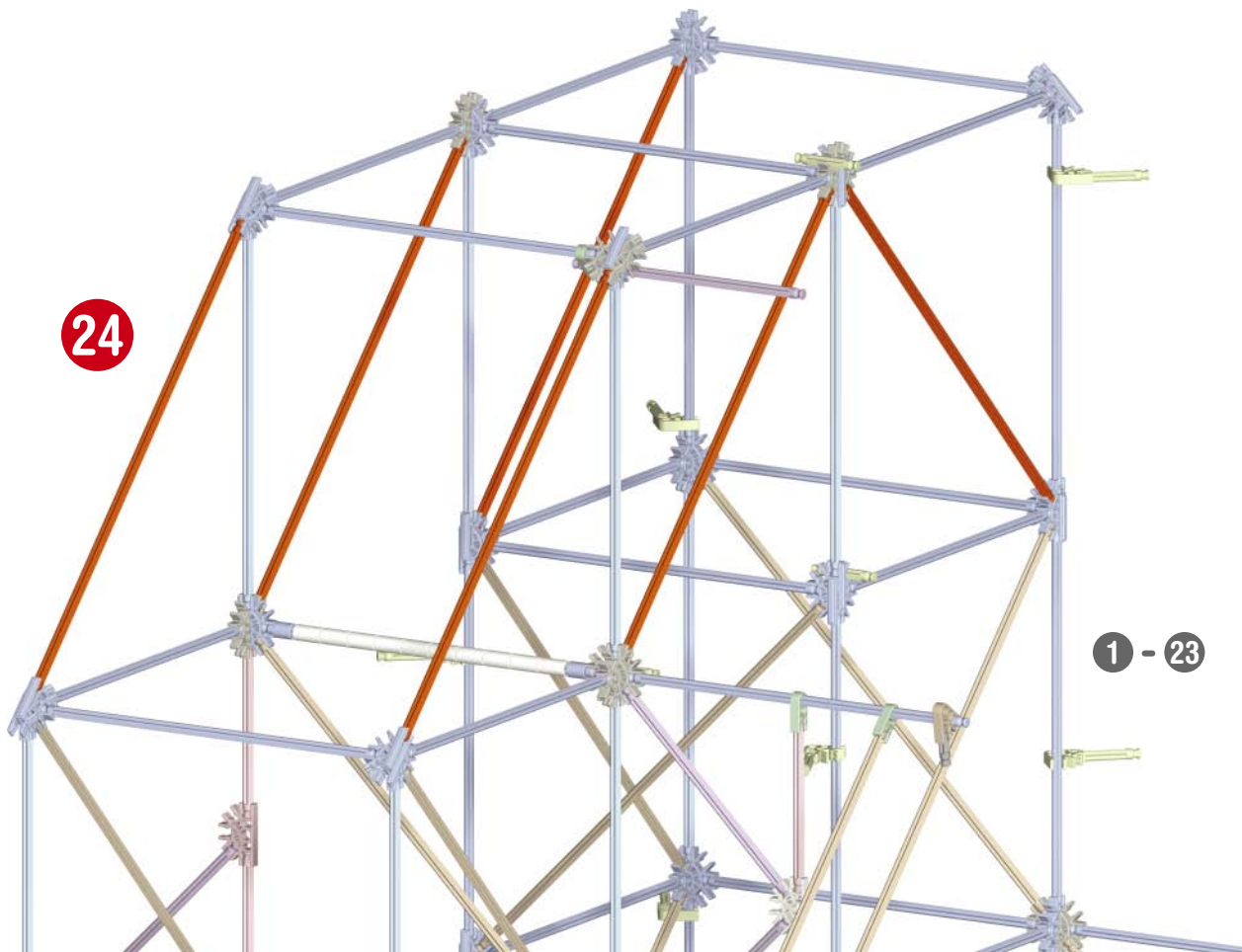

x6

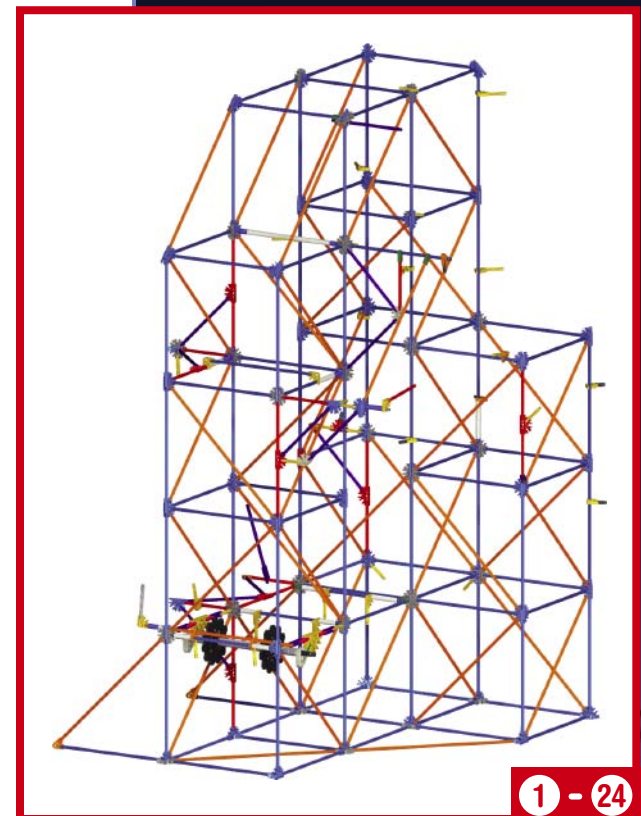

1 - 24

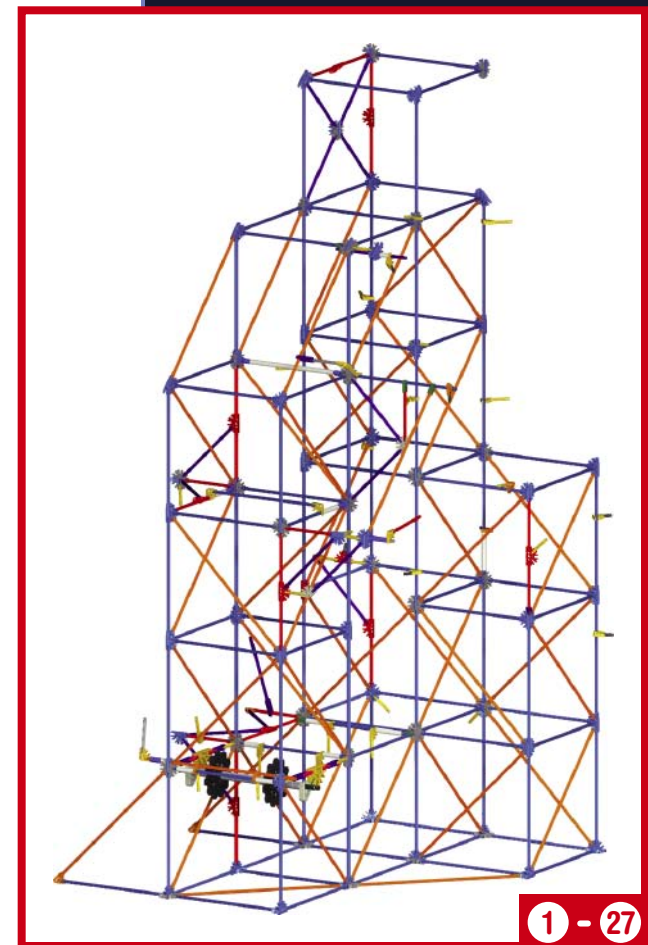
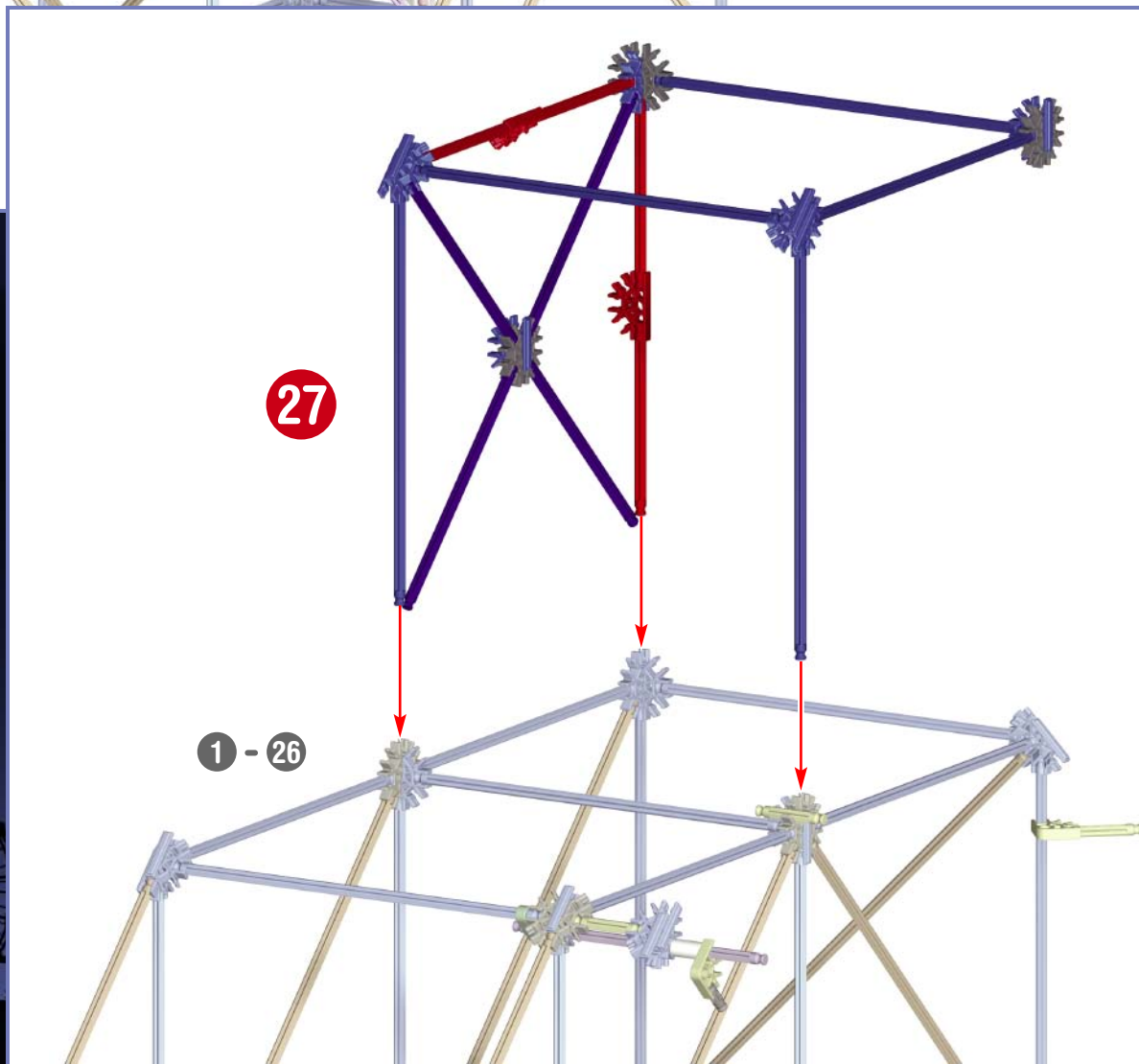
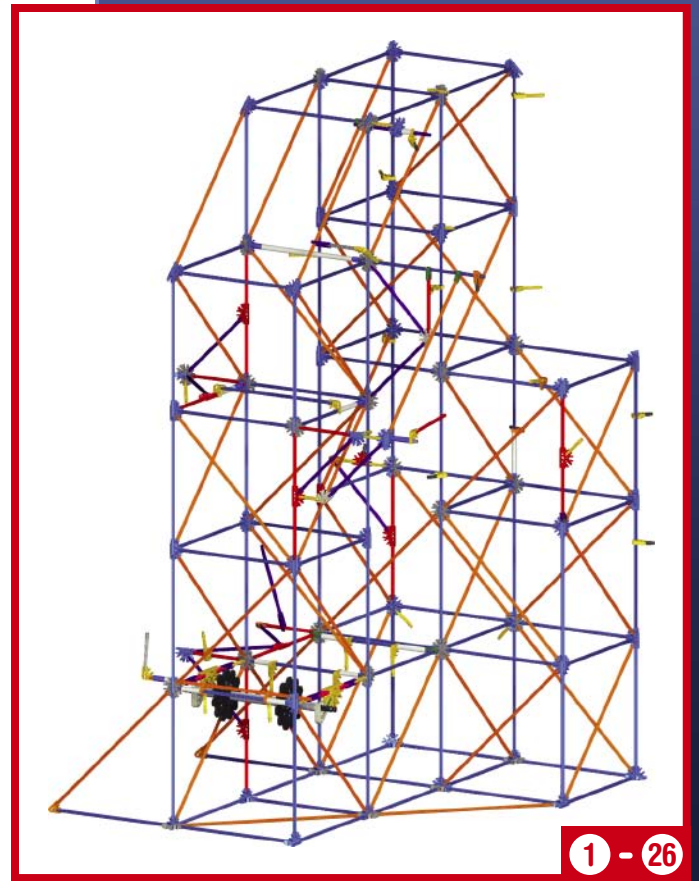
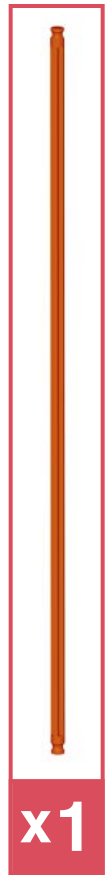
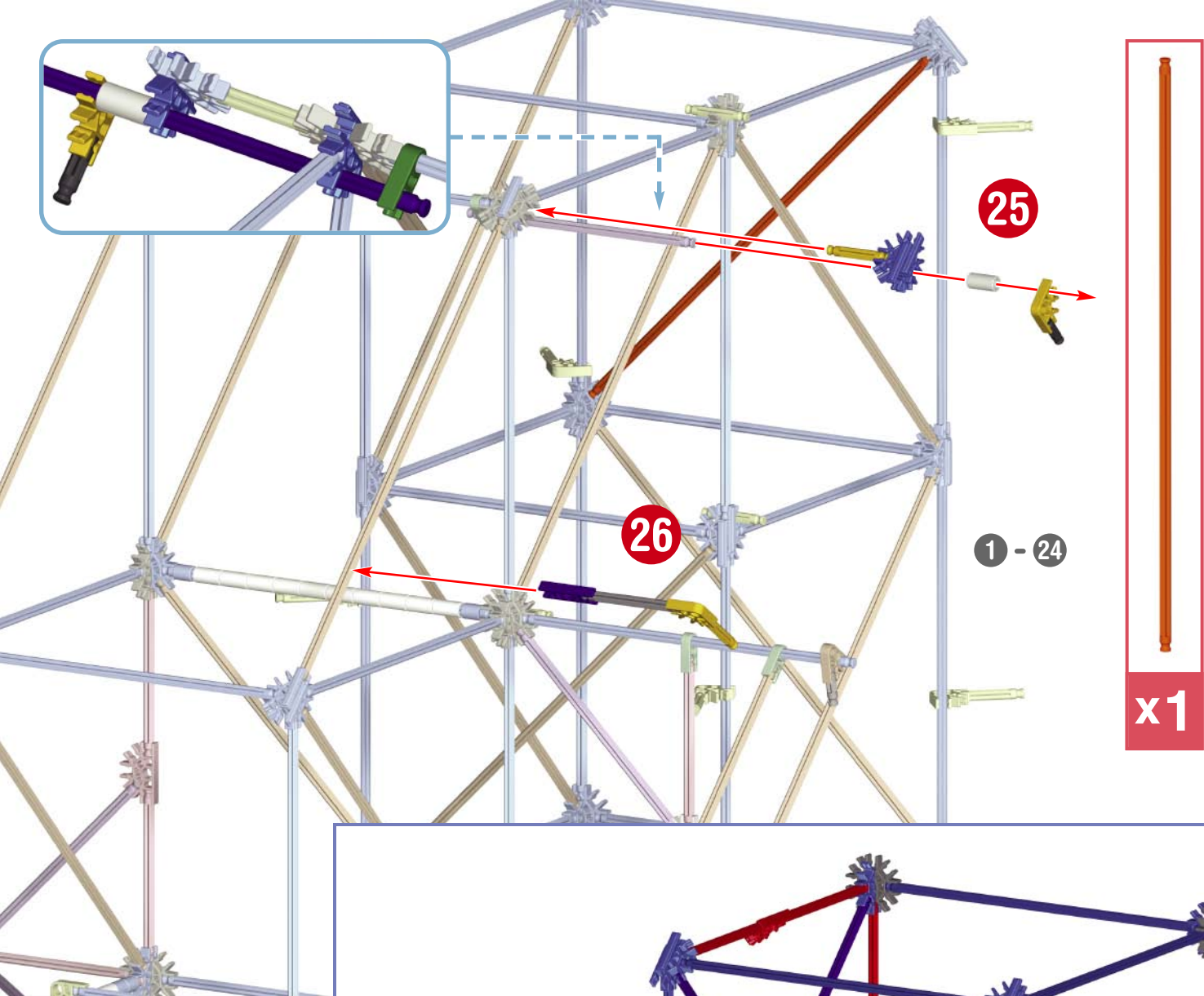

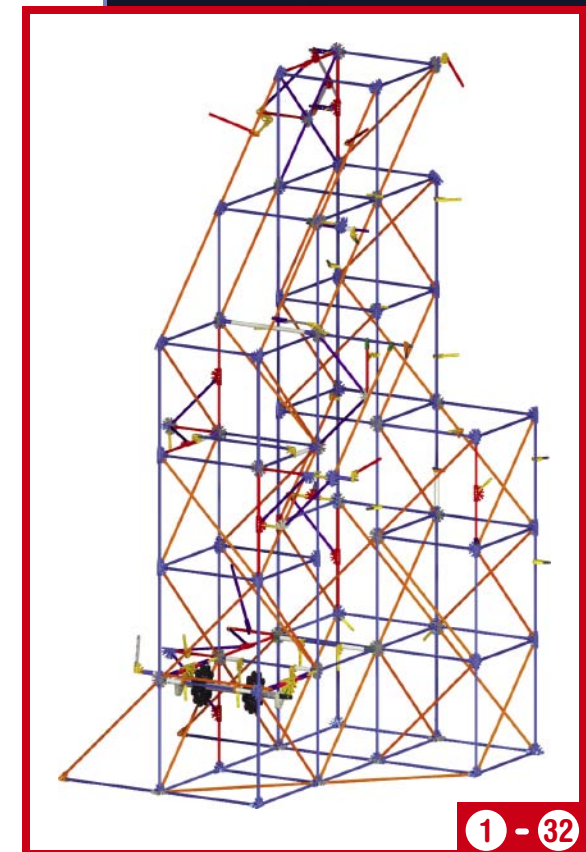
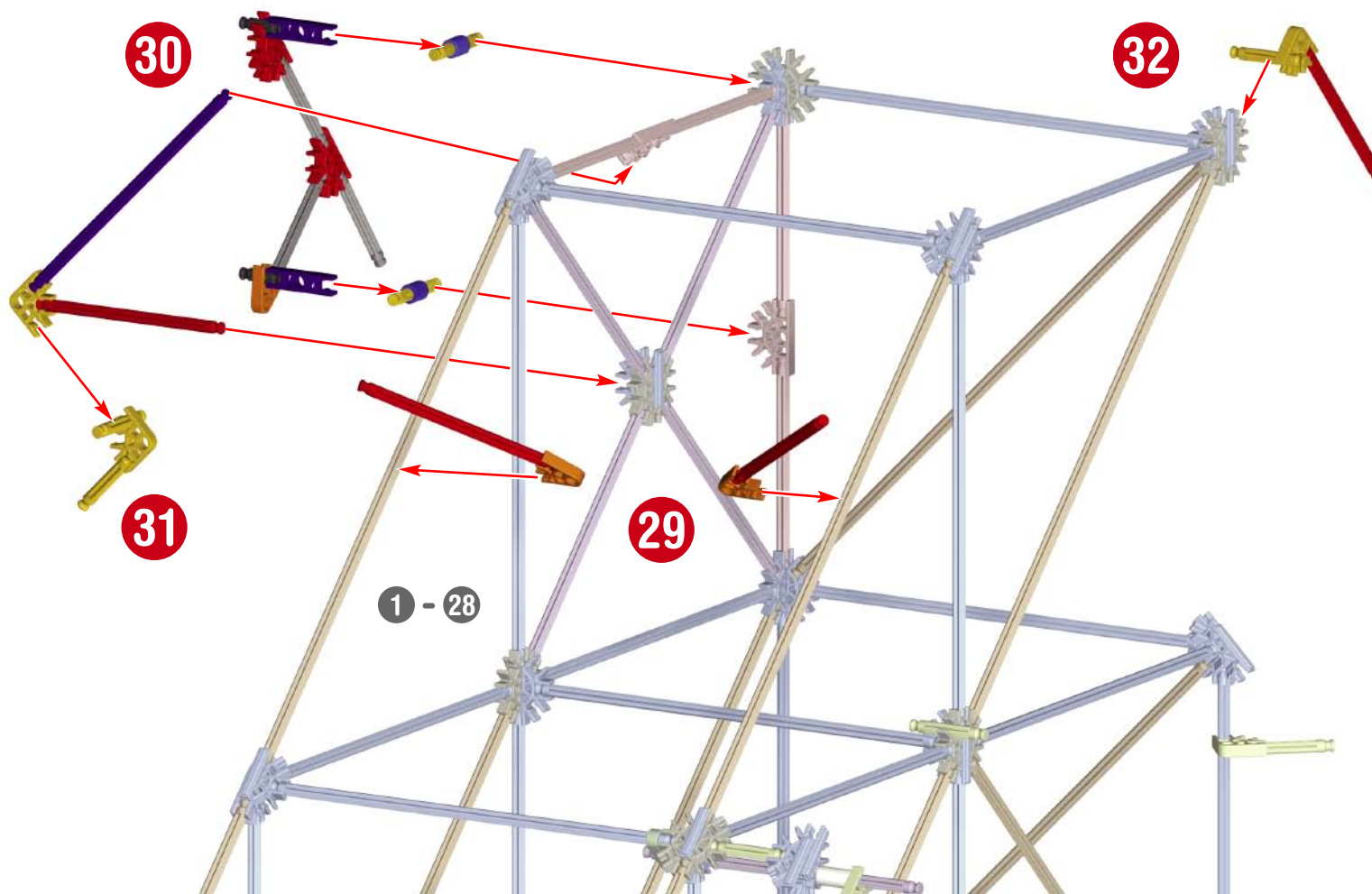
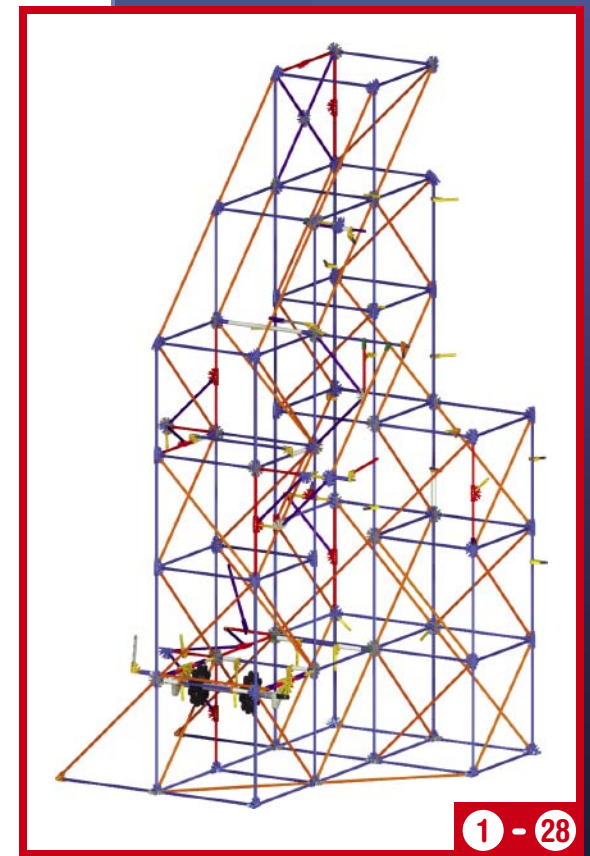
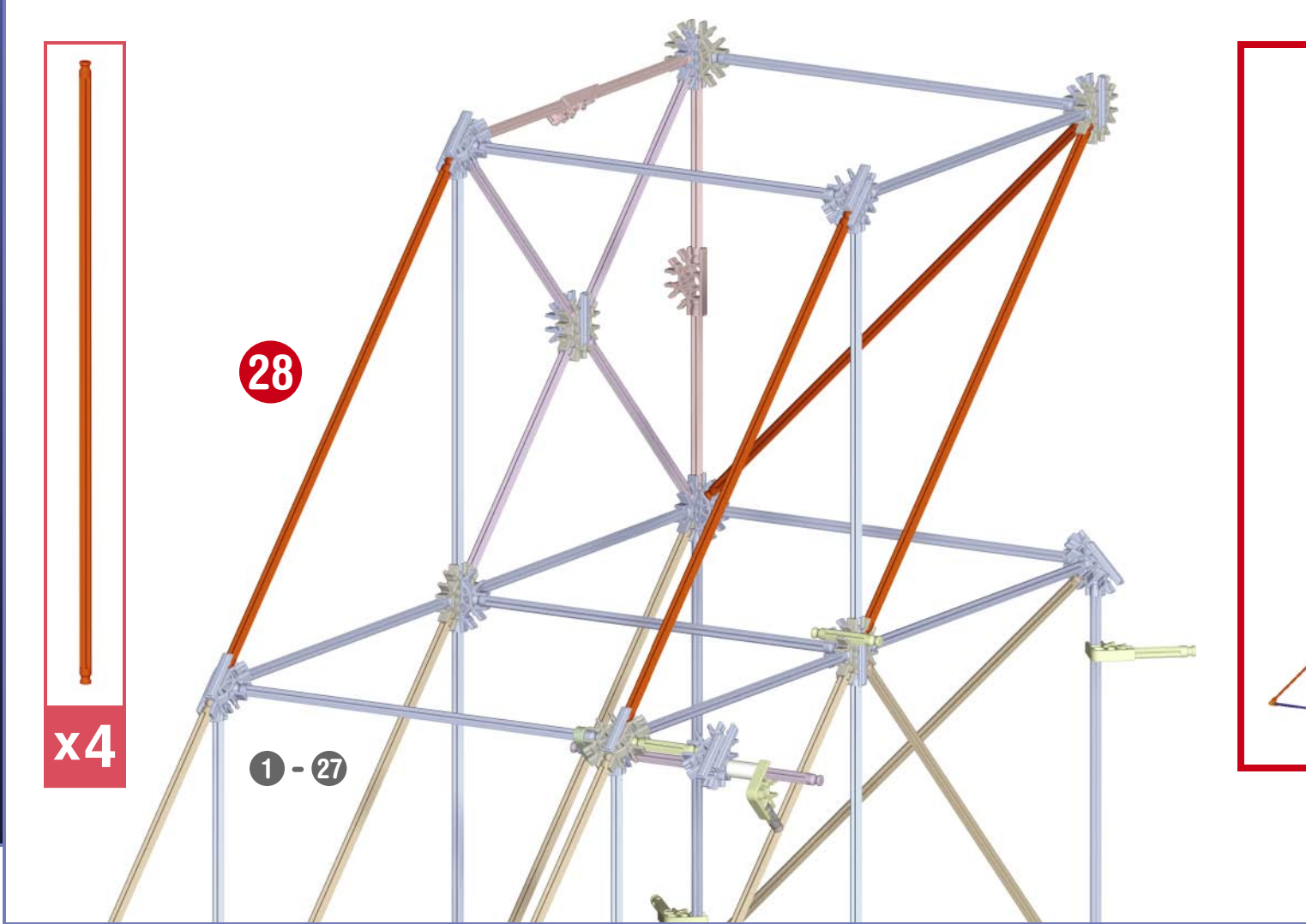

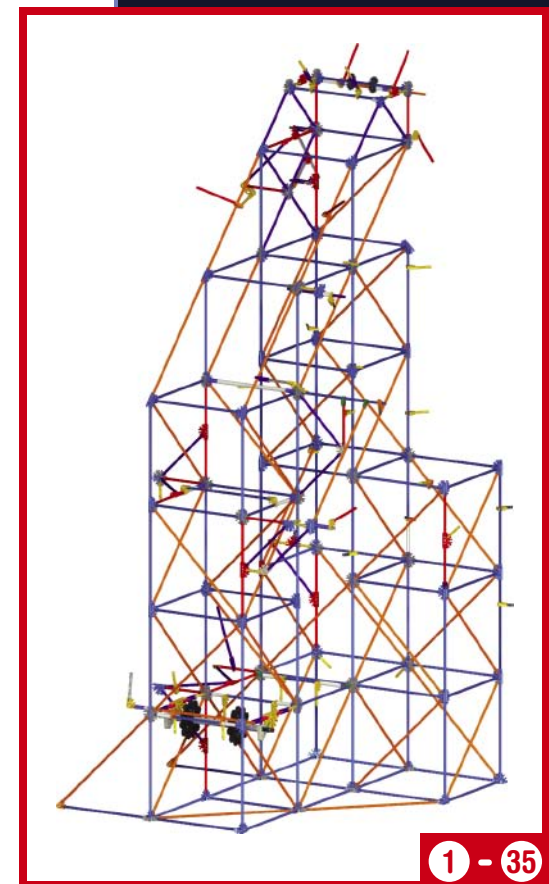
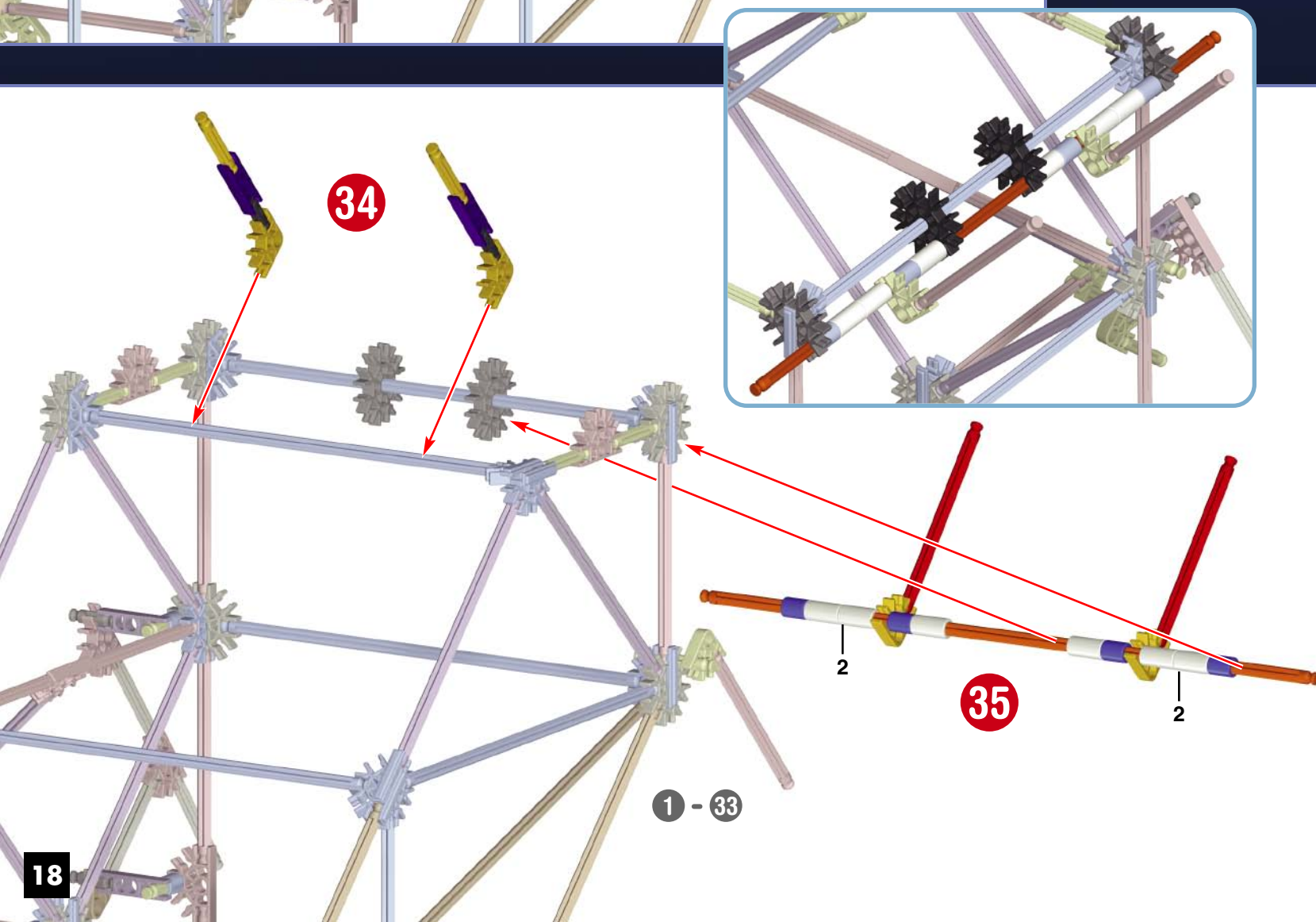
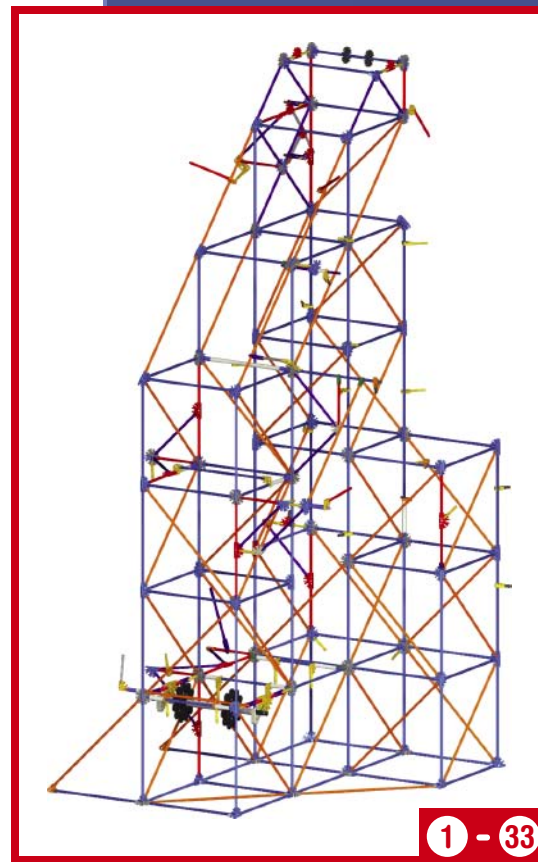
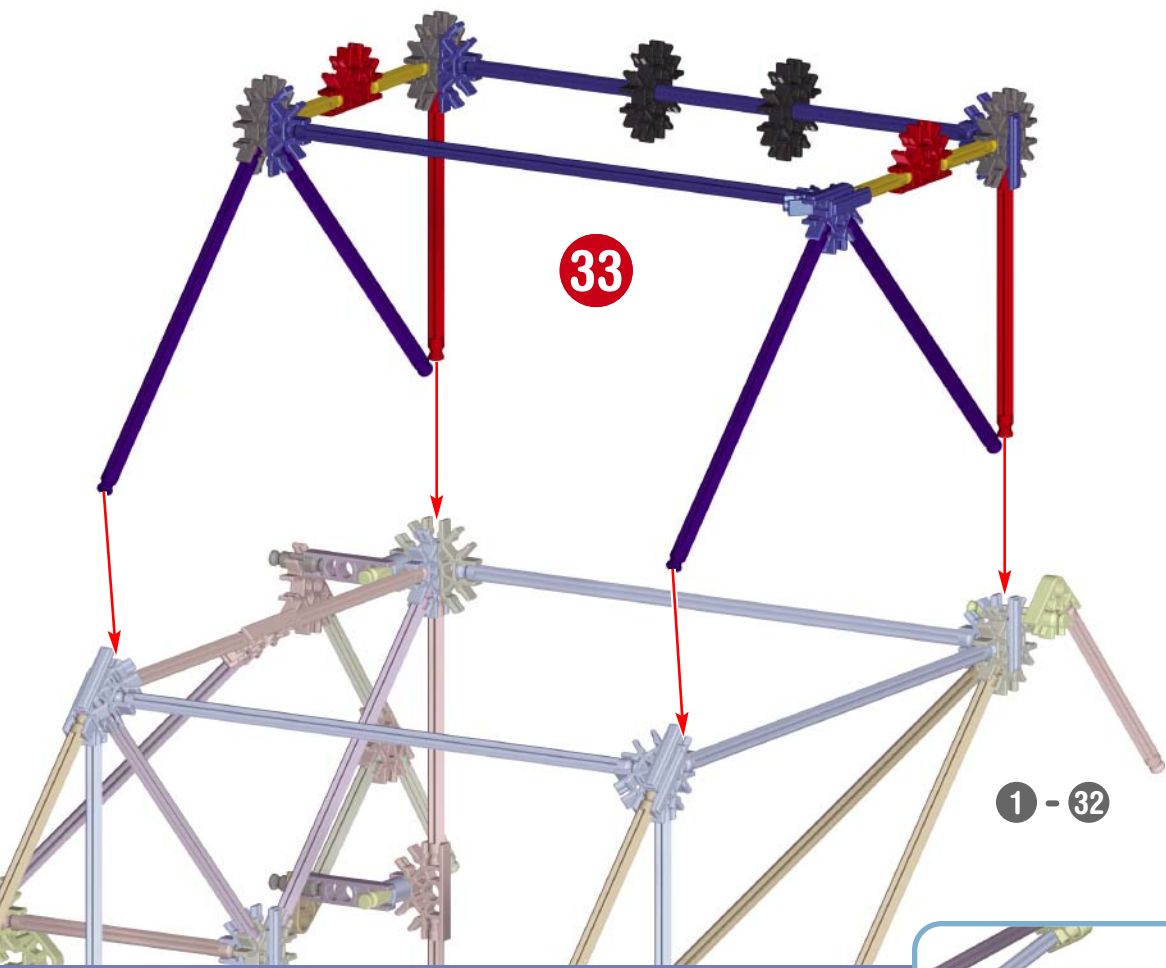



36 - 38

- Ⓔ EN Did you install 2 AA (or LR6) batteries in the motor?
- Ⓔ ES ¿Instalaste dos pilas AA (o LR6) en el motor?
- Ⓔ FR Est-ce que tu as installé 2 piles AA (ou LR6) dans le moteur ?
- Ⓔ DE Hast du 2 Batterien der Baugröße AA (oder LR6) eingelegt?
- Ⓔ IT Hai installato 2 batterie AA (o LR6) nel motore?
- Ⓔ PT Foram instaladas as pilhas 2 AA (ou LR6) no motor?
- Ⓔ NL Heb je er 2 AA (of LR6) batterijen ingestoken?

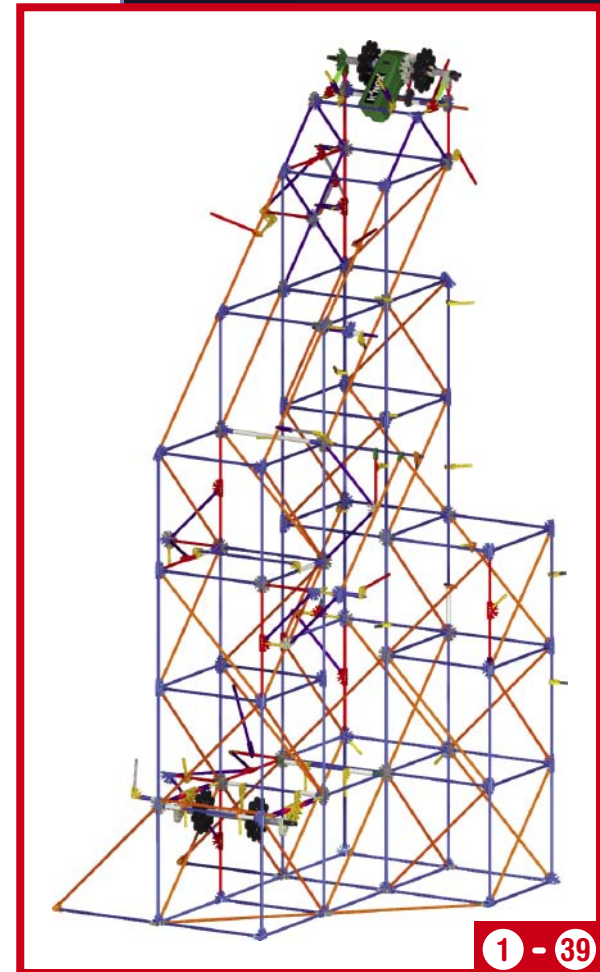
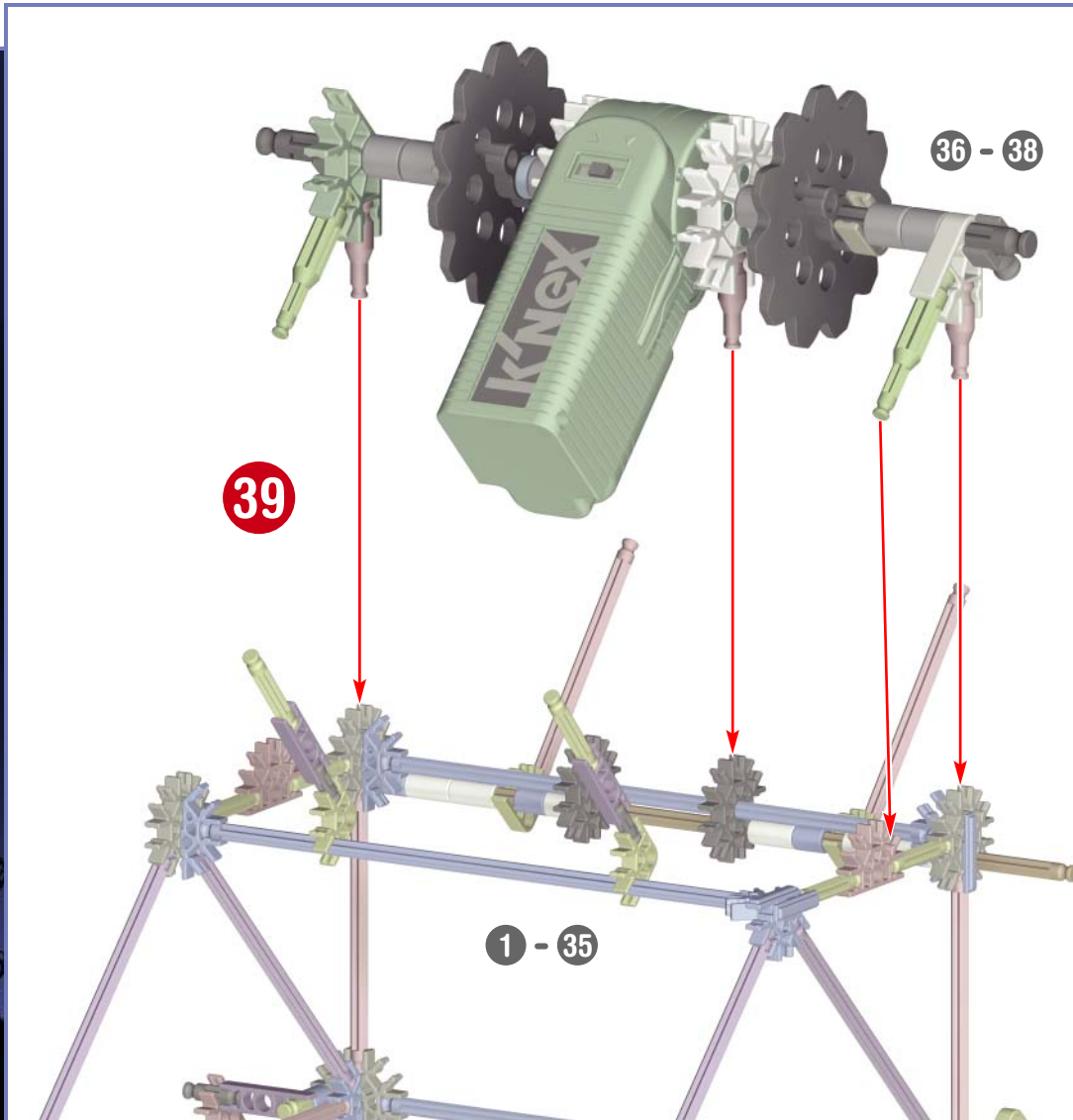

1 - 39

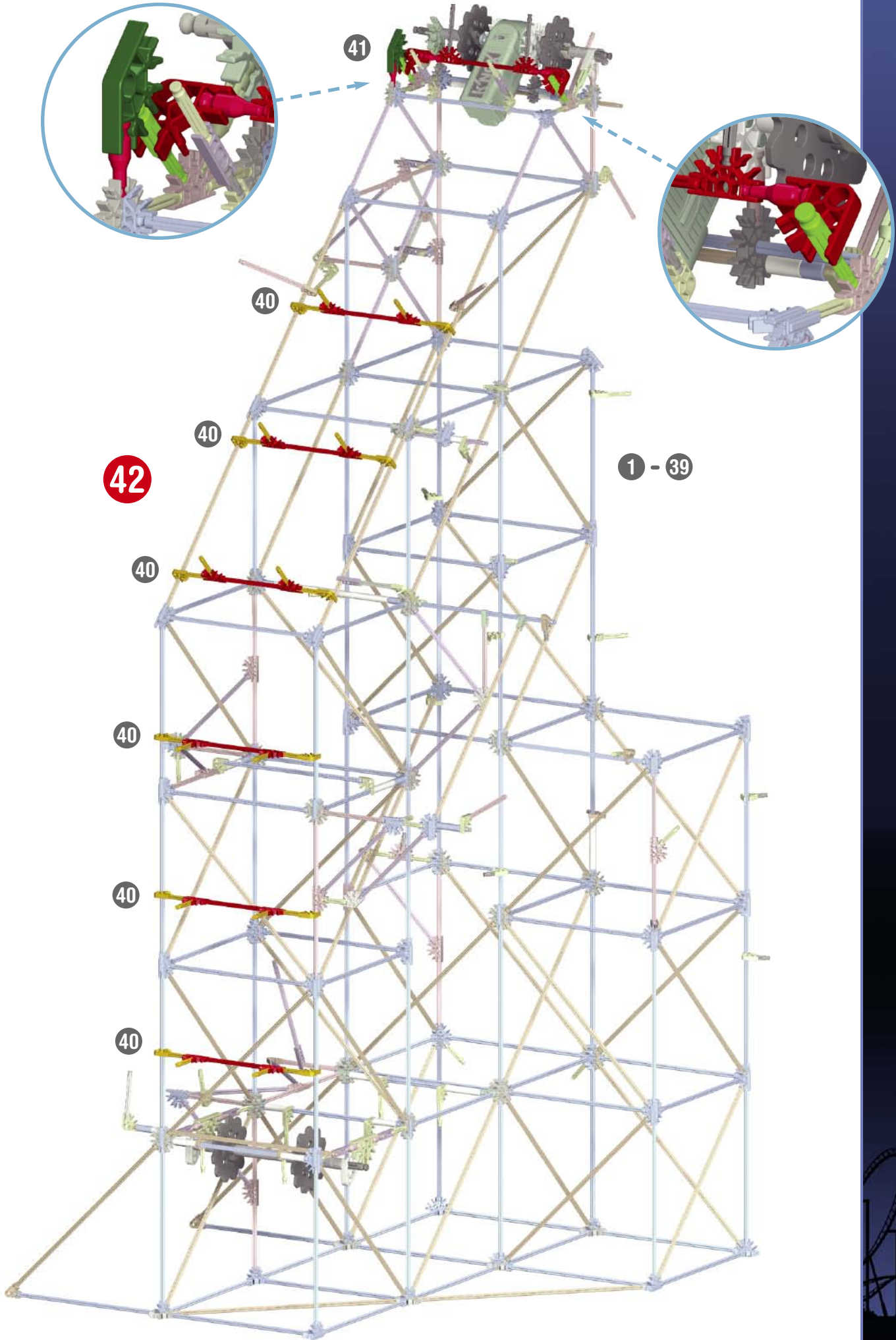
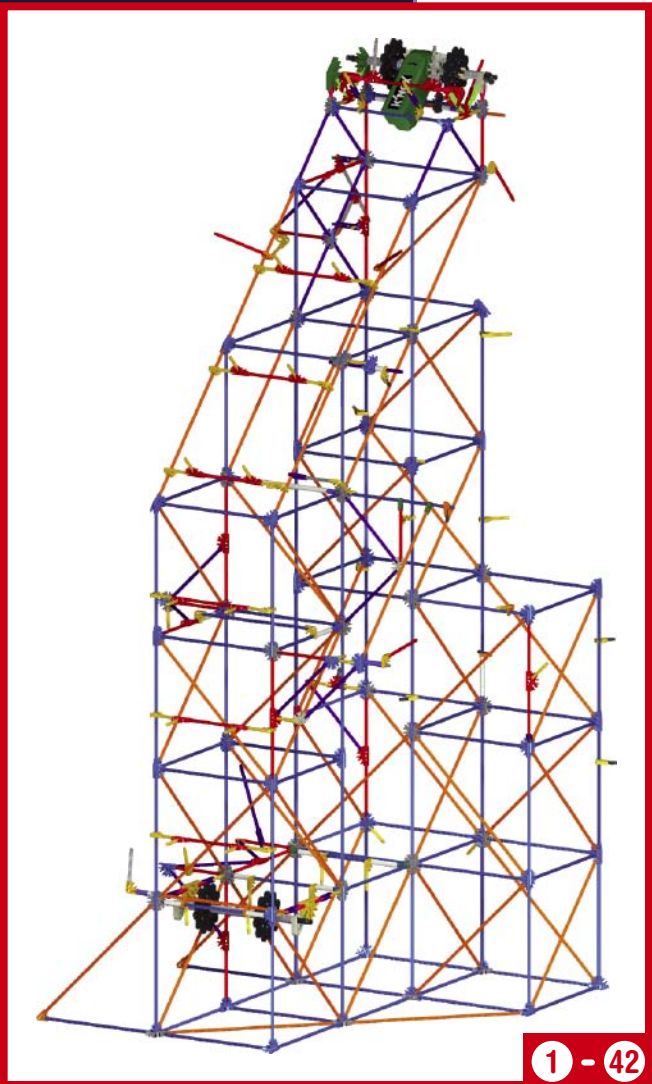
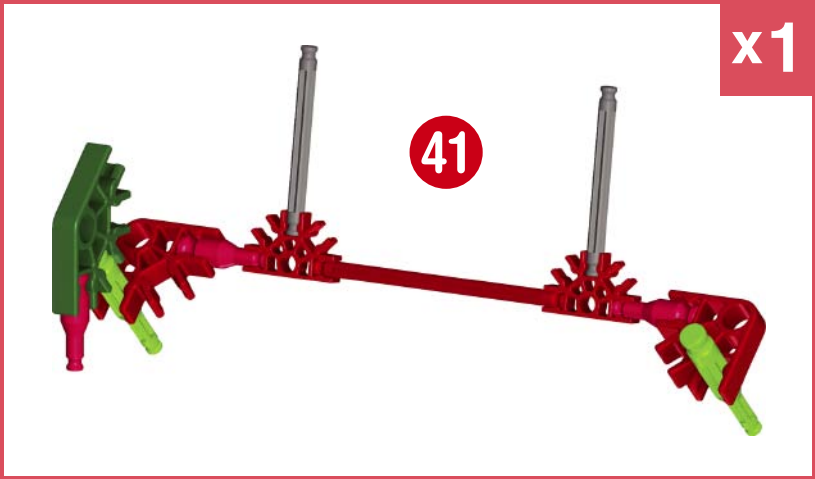
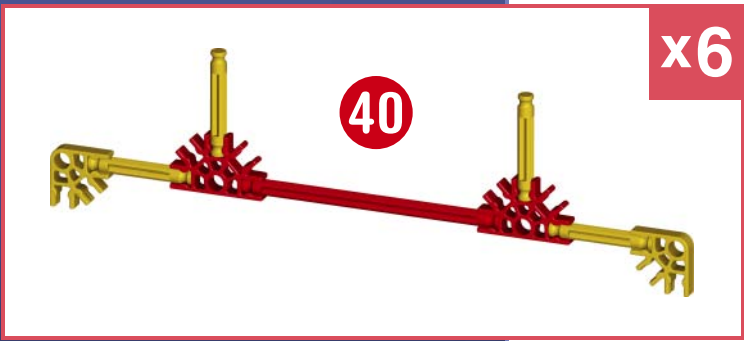

Track Building Tips: Consejos para armar las pistas: Conseils pour le pistes :

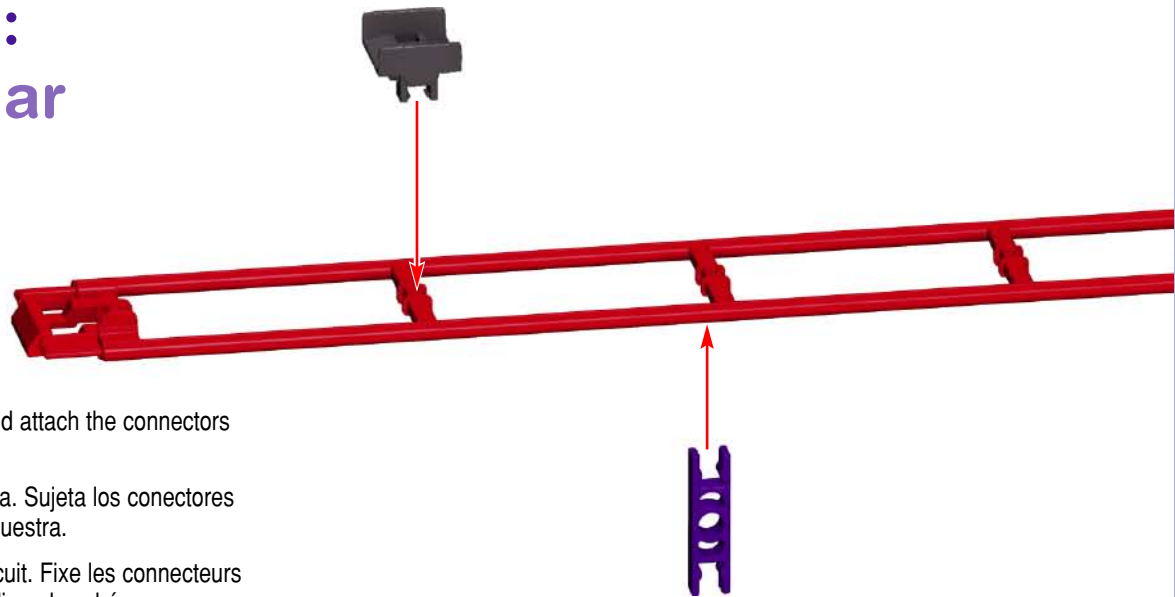

- Ⓔ Attach the black chain guides to the top of the track and attach the connectors to the bottom of the track exactly as shown.
- Ⓔ Sujeta las Guías de Cadena al lado superior de la Pista. Sujeta los conectores en el lado inferior de la Pista, exactamente como se muestra.
- Ⓔ Fixe les guides de chaîne à la partie supérieure du circuit. Fixe les connecteurs à la partie inférieure du circuit exactement comme l'indique le schéma.

- Ⓔ Be sure to push the connectors on firmly until they "click".
- Ⓔ Empuja los Conectores hacia adentro hasta que oigas un "clic".
- Ⓔ Pousse bien les connecteurs jusqu'à ce qu'ils « cliquent ».

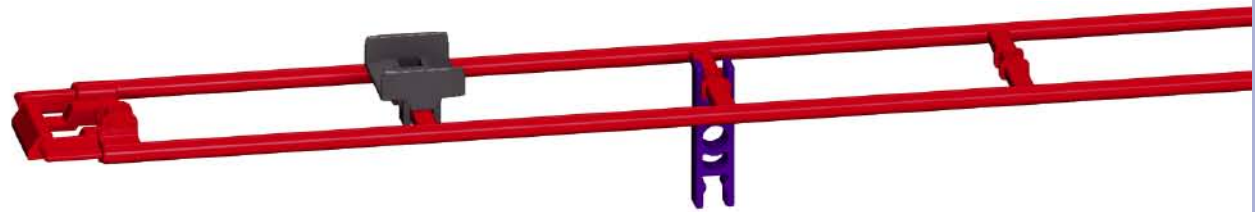

- Ⓔ Always connect the track top side to top side throughout the build.
- Ⓔ Al construir, conecta siempre la Pista de lado superior a lado superior.
- Ⓔ Connecte toujours le côté supérieur du circuit contre le côté supérieur tout au long de la construction.

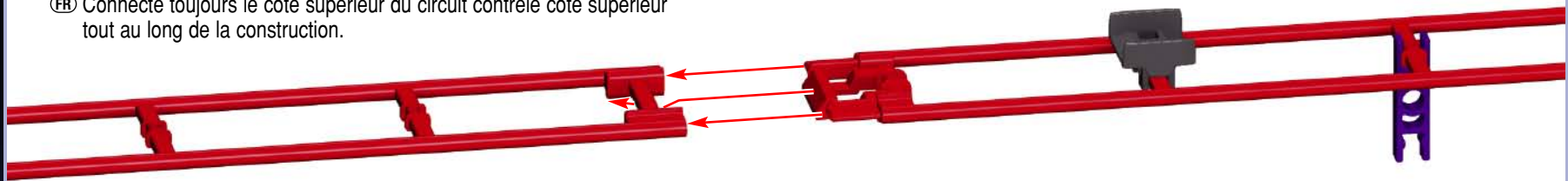

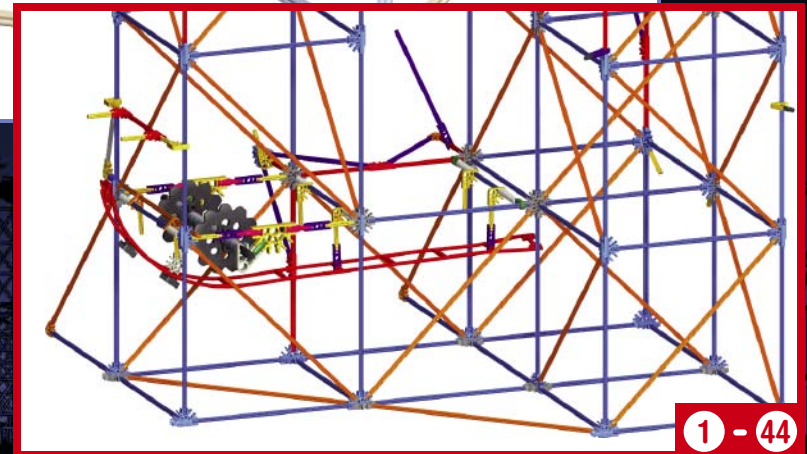
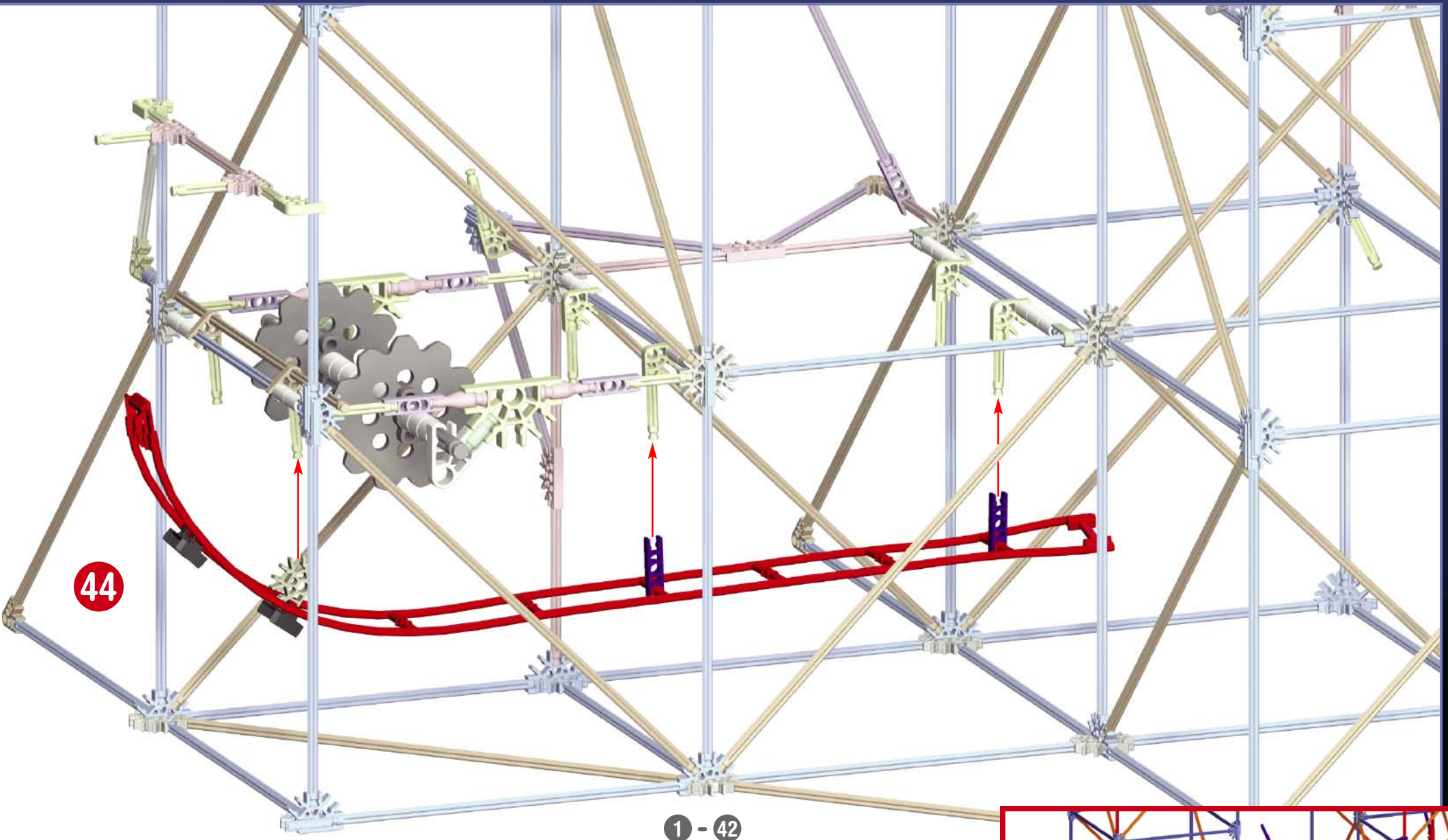
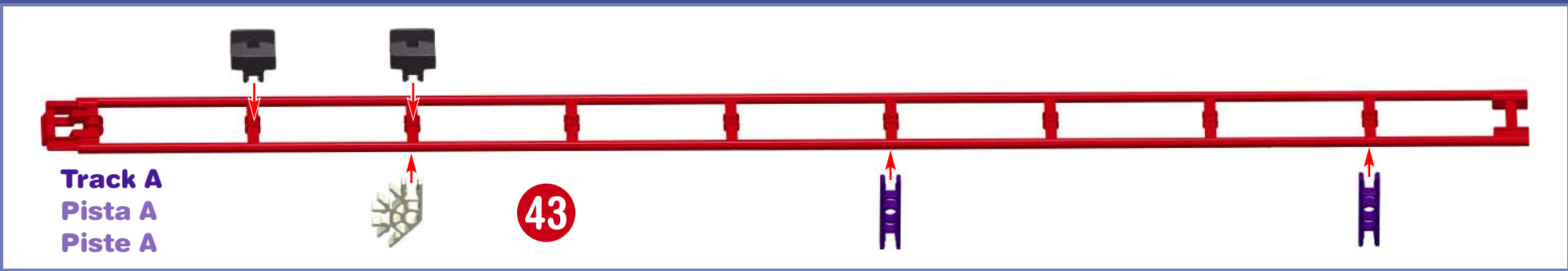

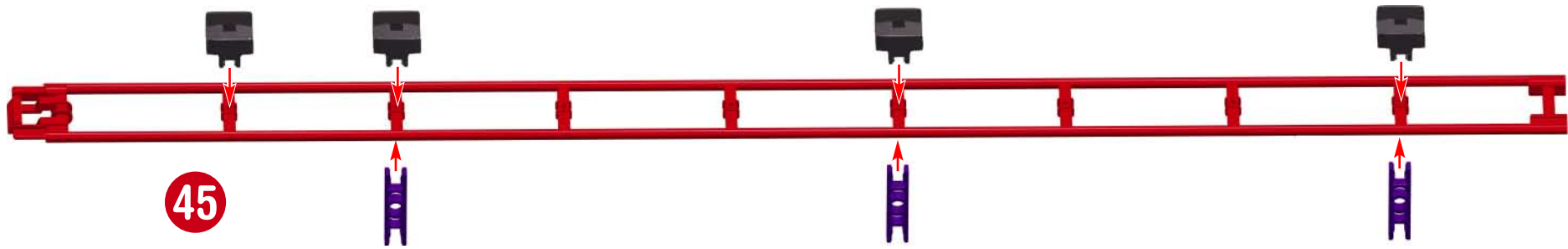

45

46

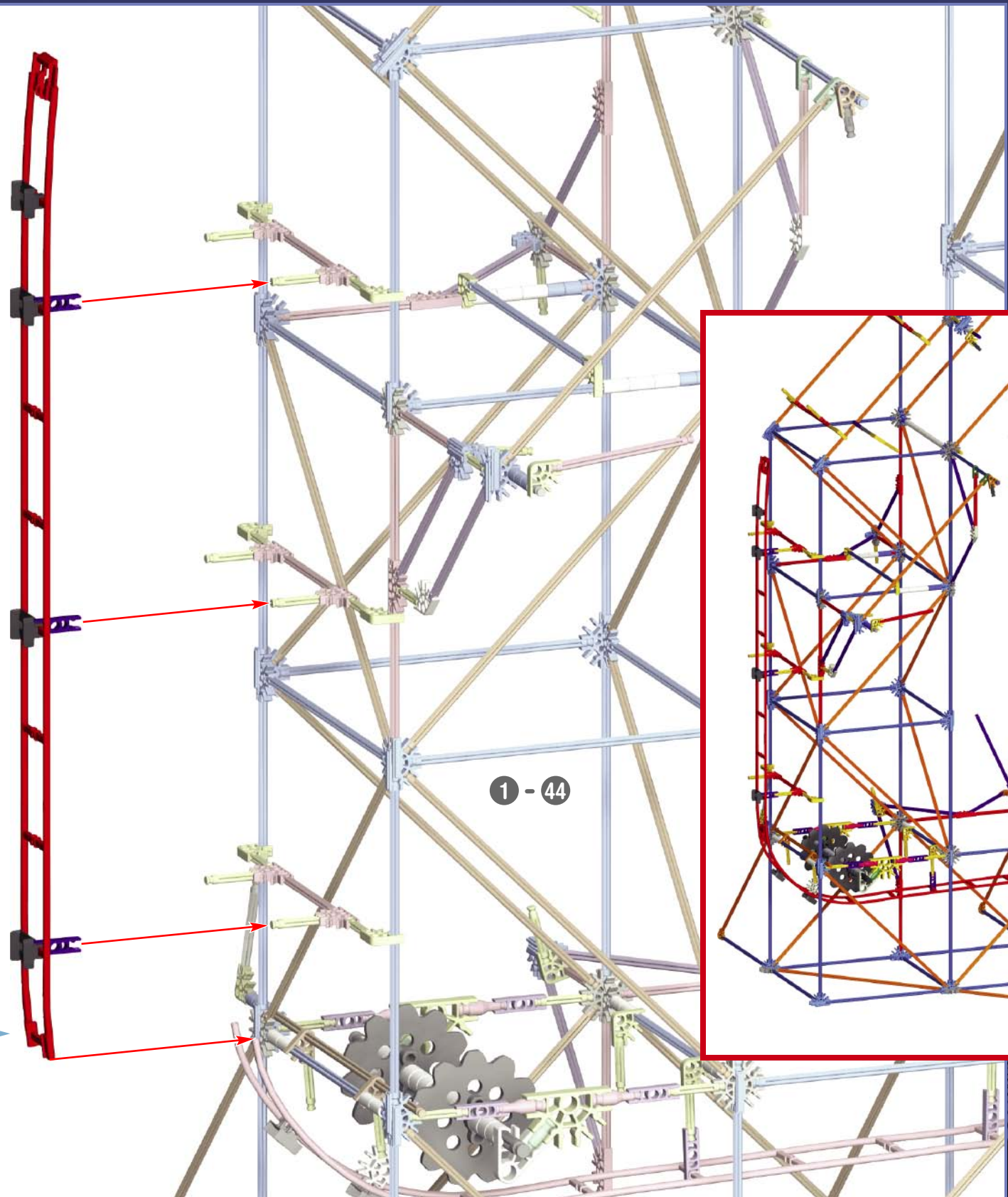

1 - 44

1 - 46

(EN) Always join this end of the track to the previous track piece first, then connect the rest of the track to the tower.

(ES) Siempre unirse a este extremo de la pista a la pieza primera pista anterior, a continuación, conecte el resto de la pista a la torre.

(FR) Toujours joindre à cette extrémité de la voie à la pièce de la piste précédente, puis connecter le reste de la piste à la tour.

(DE) Immer beitreten dieses Ende der Strecke zum vorherigen Track Stück zuerst, dann treten der Rest der Strecke auf den Turm.

(IT) Sempre partecipare a questo fine della traccia per traccia del pezzo precedente, poi collegare il resto della pista alla torre.

(PT) Sempre aderir a este final da trilha para a peça faixa anterior primeiro, e depois conectar o restante da trilha para a torre.

(NL) Altijd deelnemen aan deze eind van het spoor naar de vorige track stuk eerst, dan komen de rest van de track naar de toren.

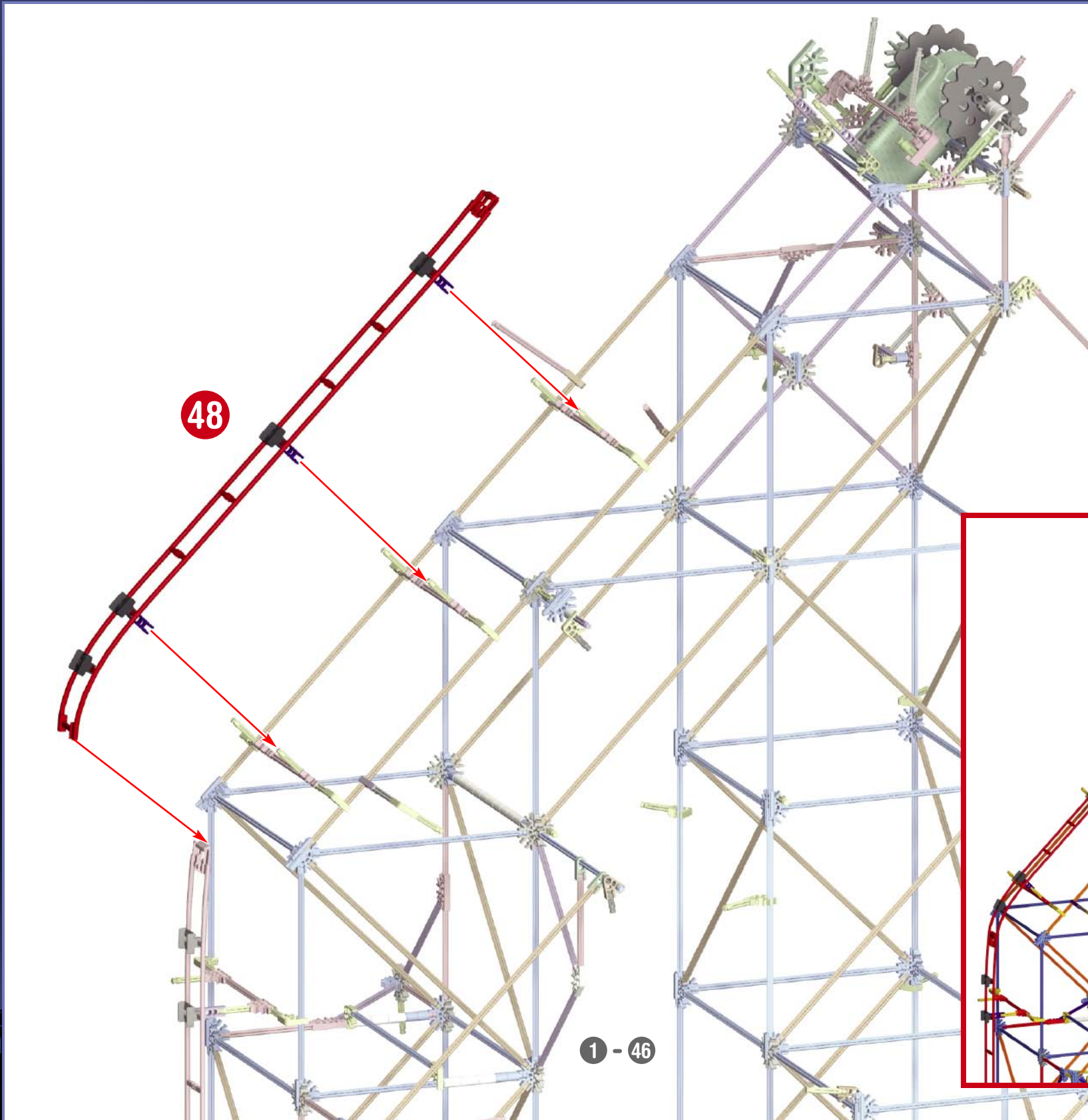
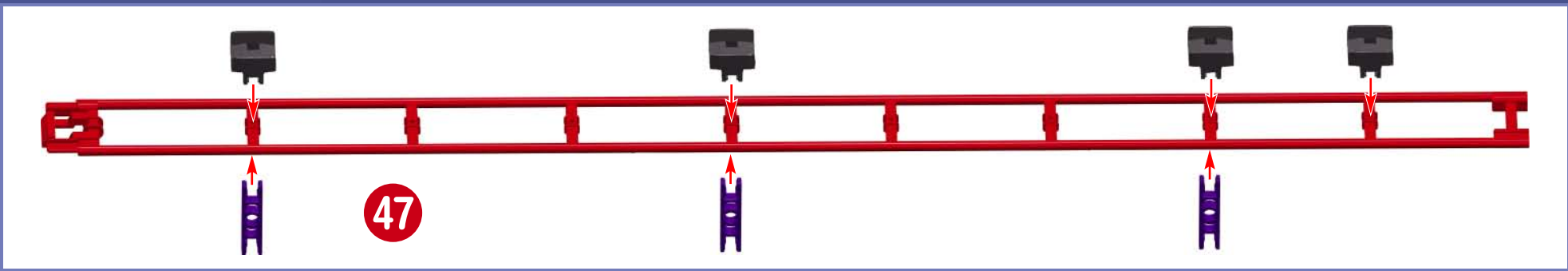

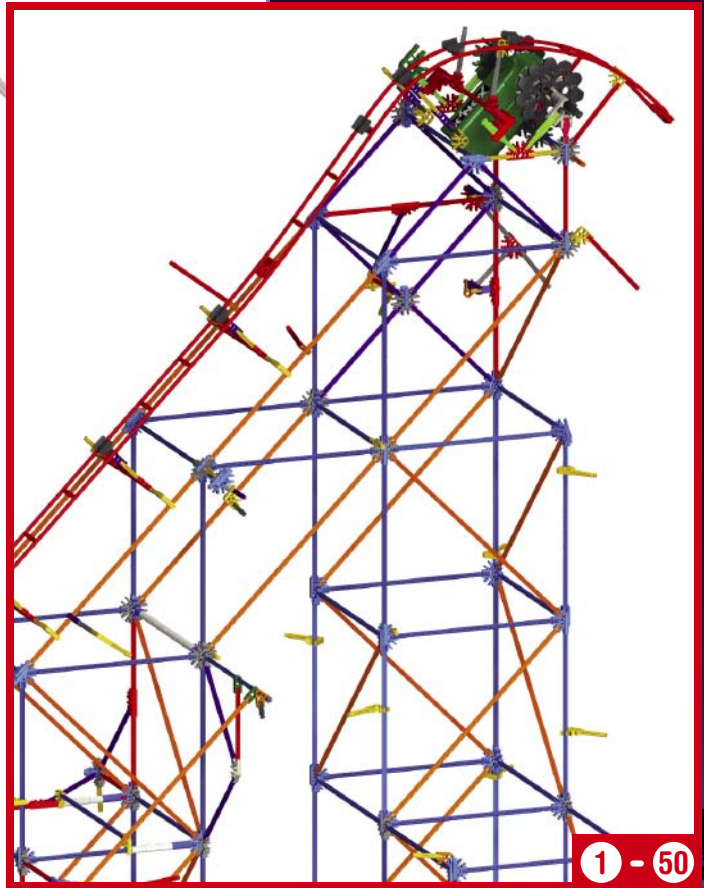
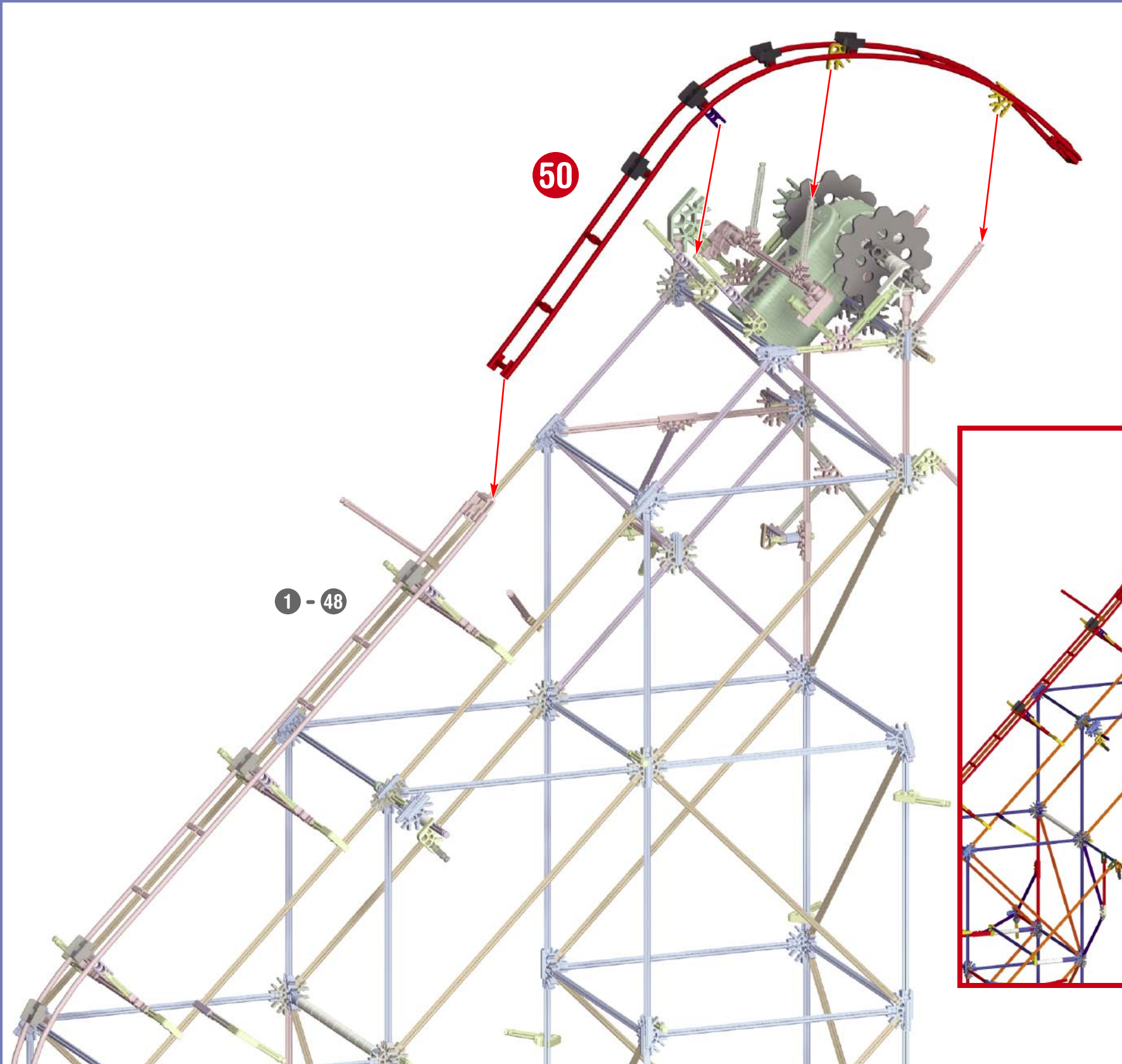
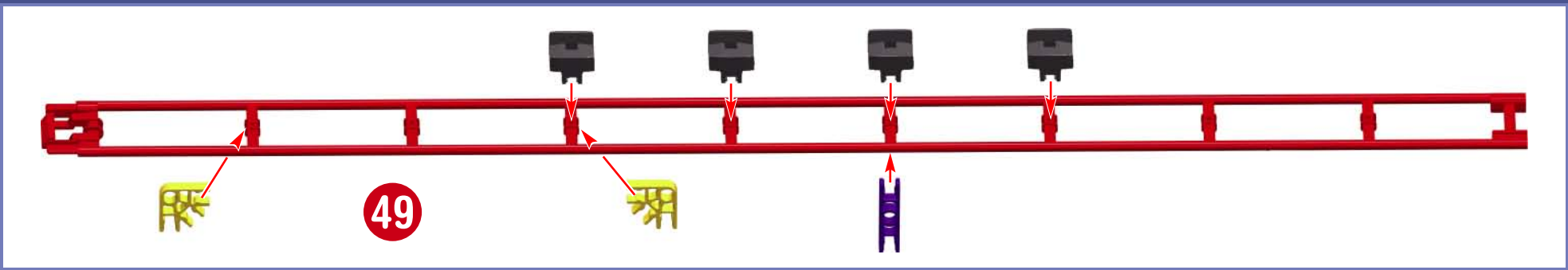



51

翔

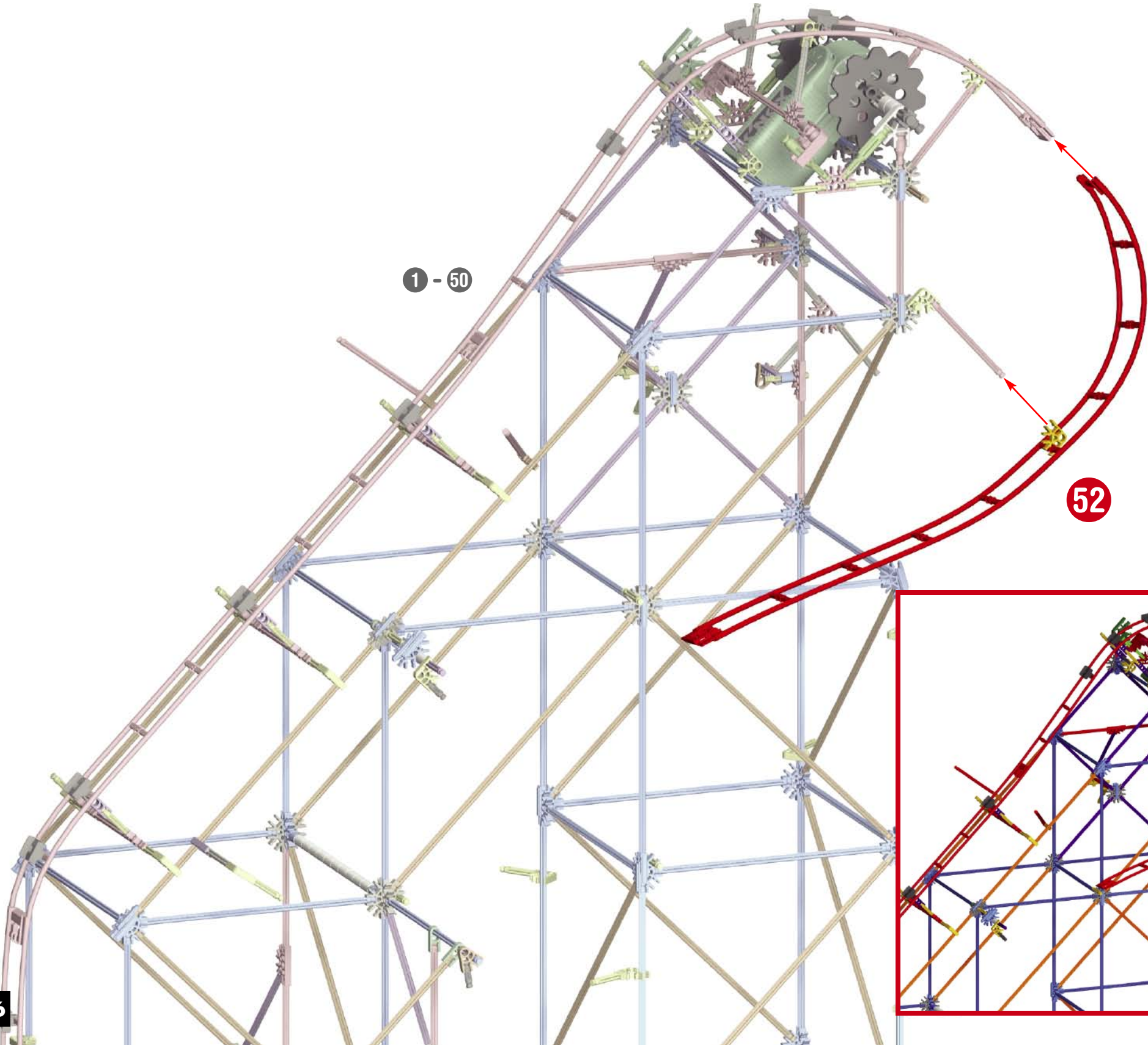

1 - 50

52

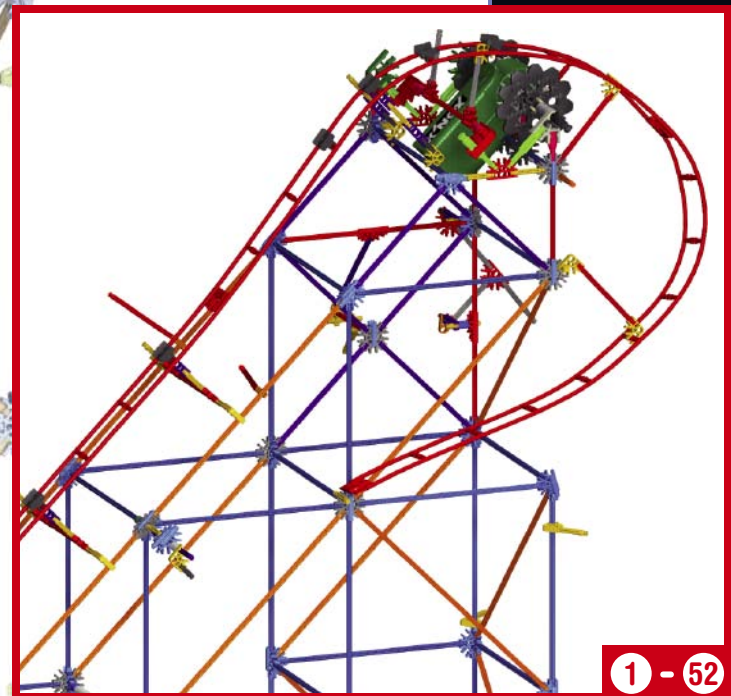

1 - 52



53

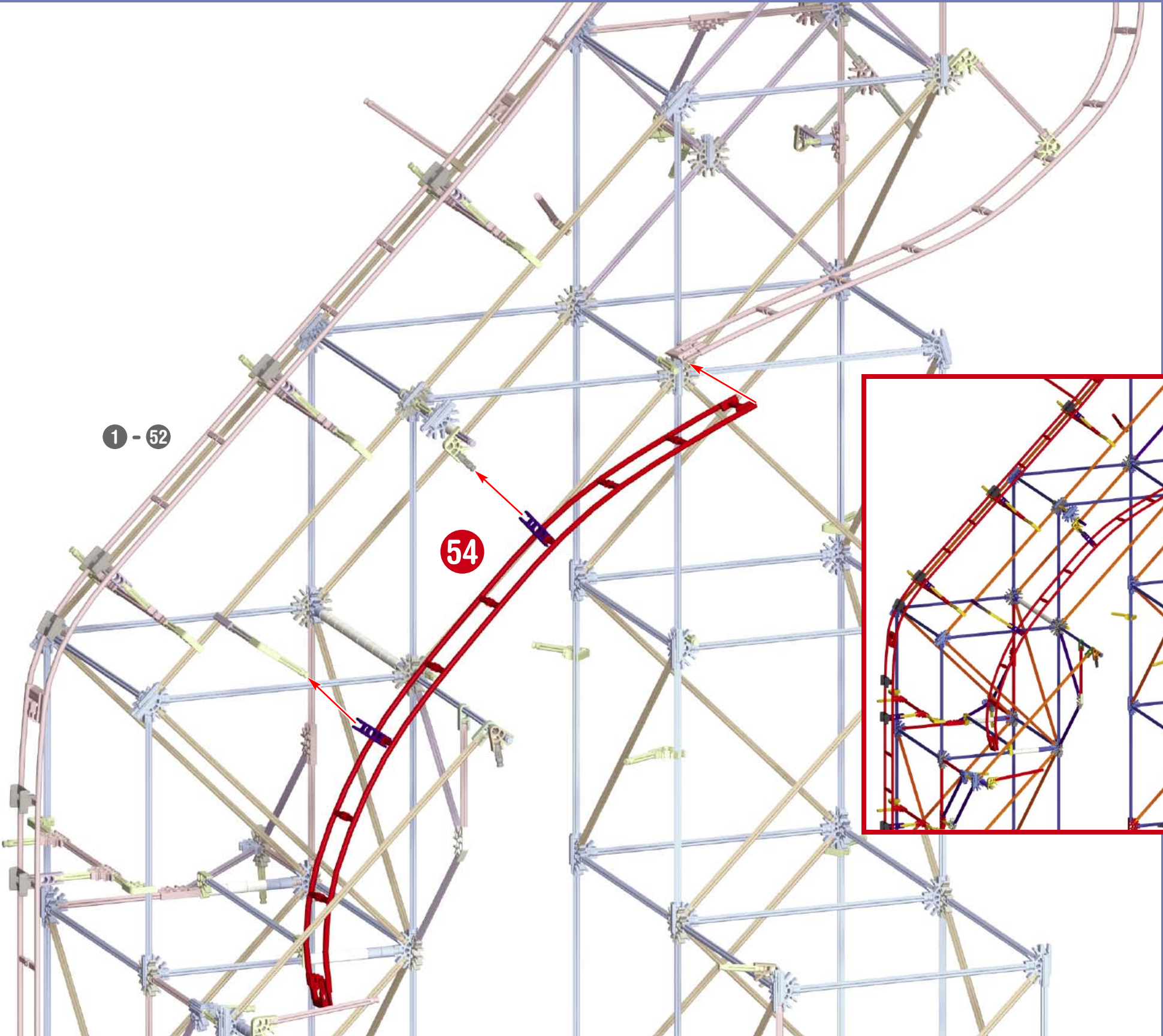

1 - 52

54

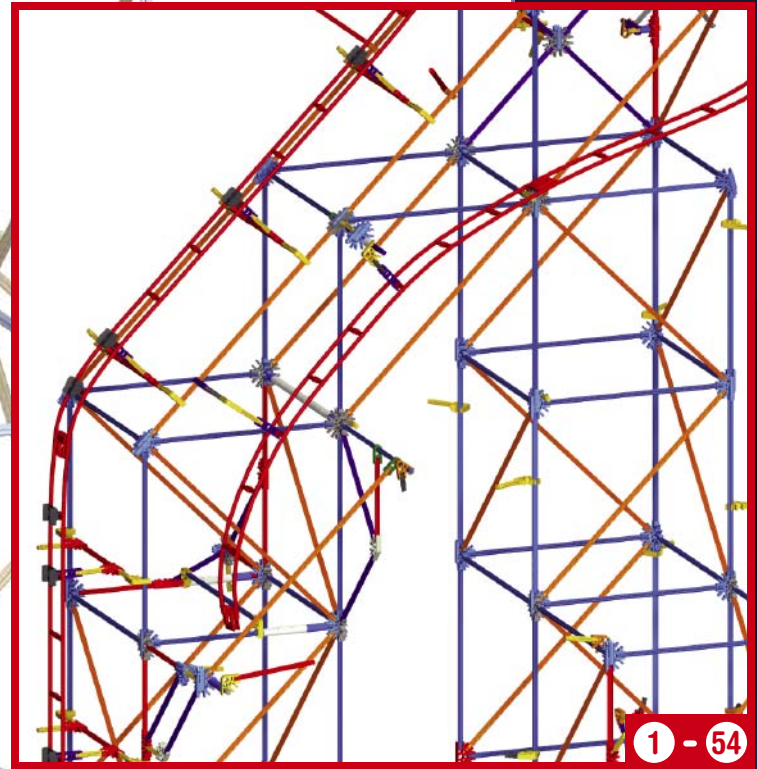

1 - 54



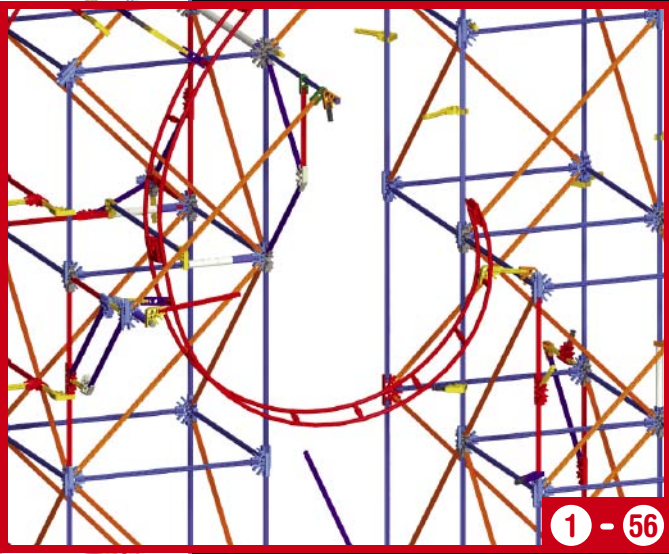
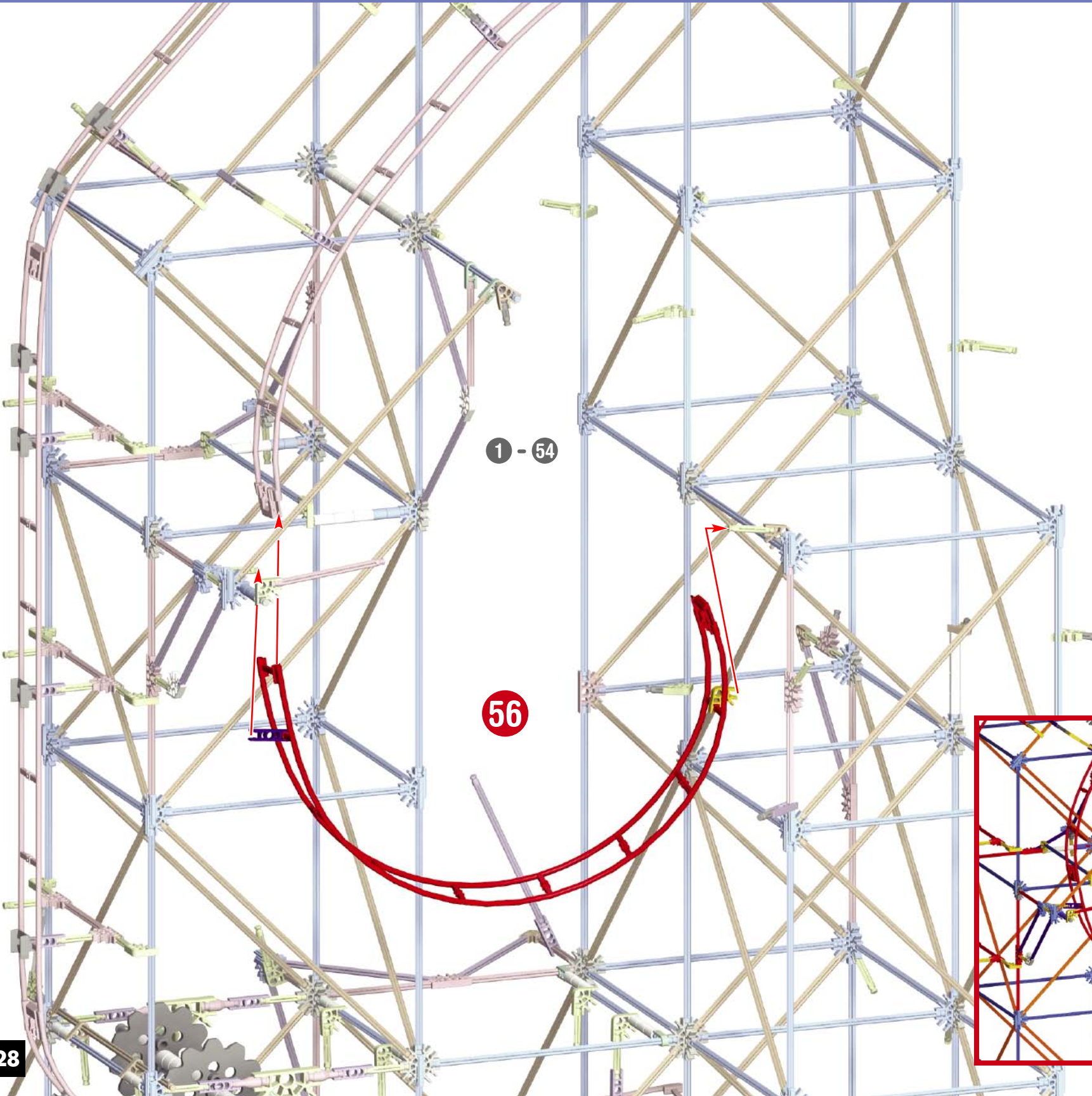
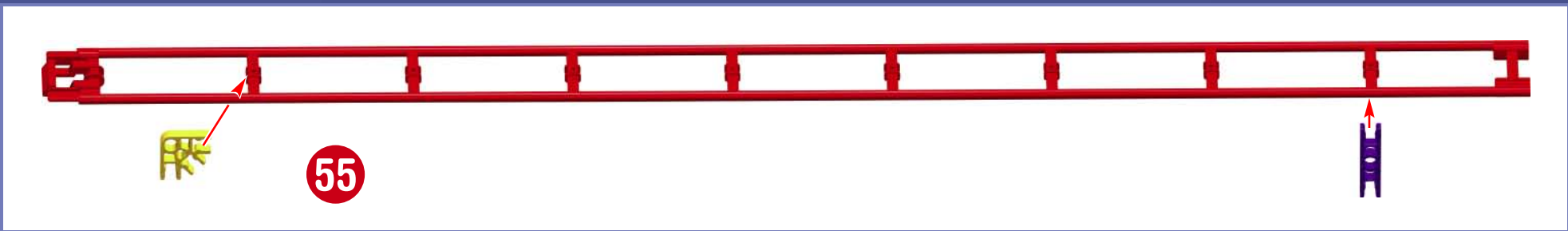



57

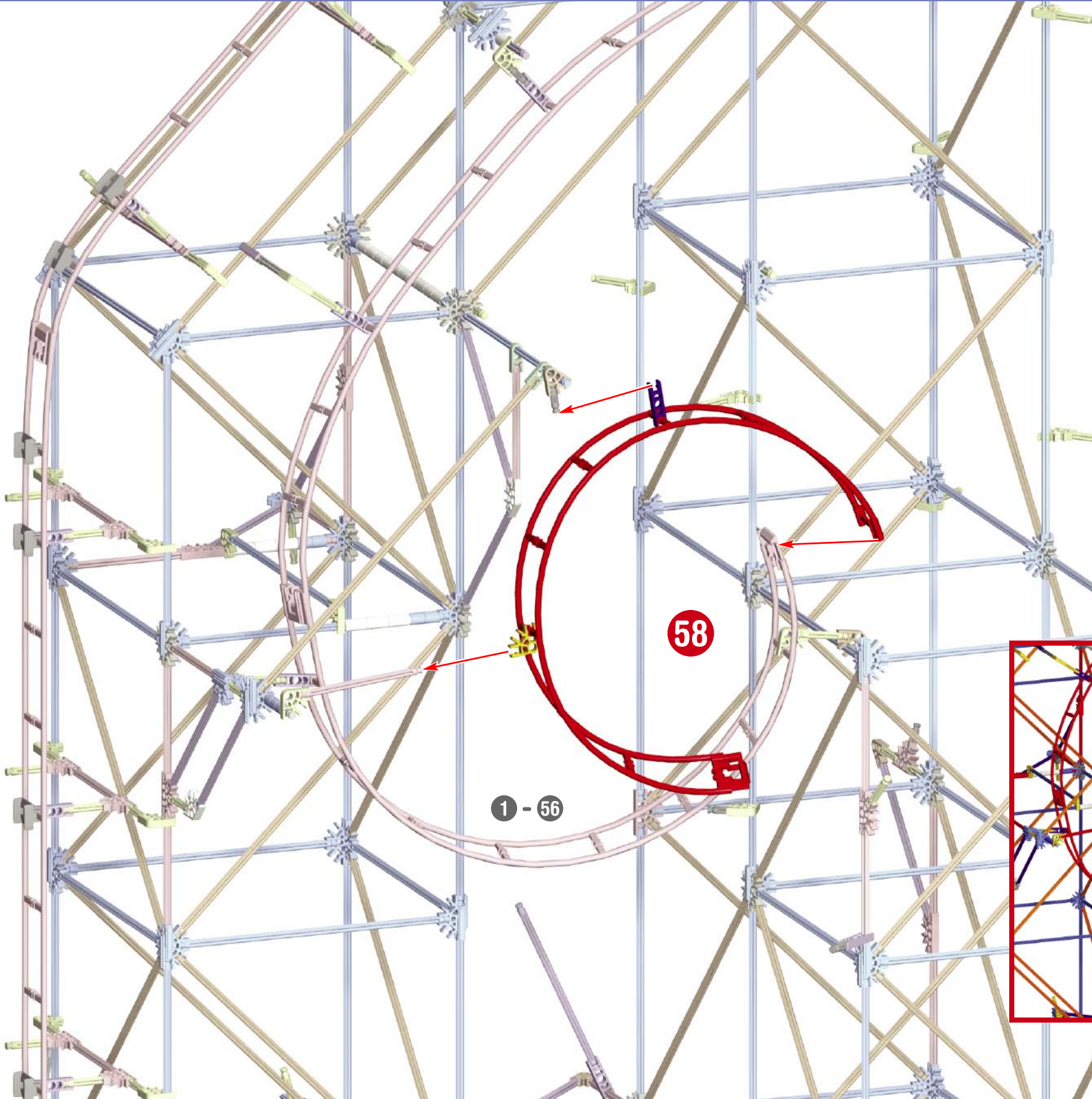

58

1 - 56

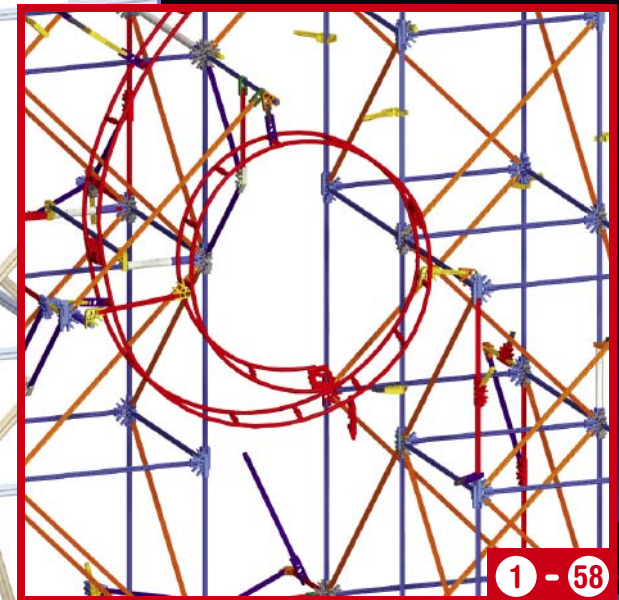

1 - 58

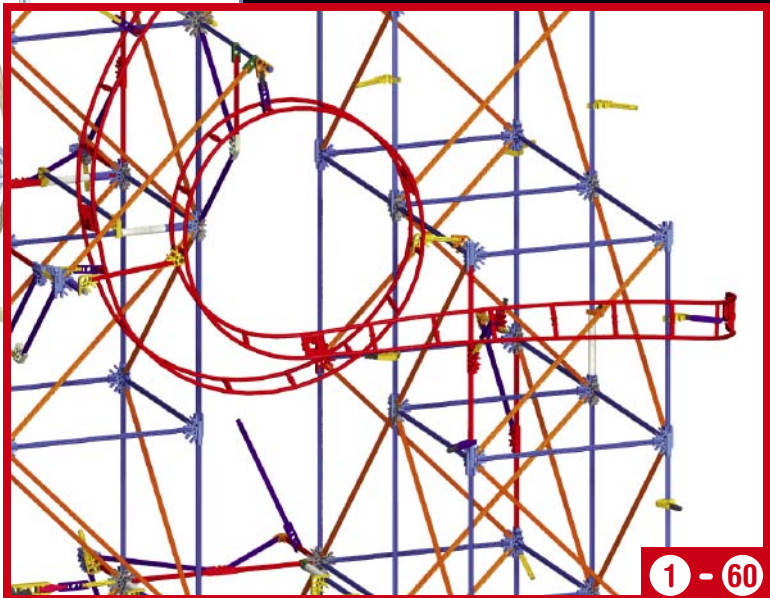
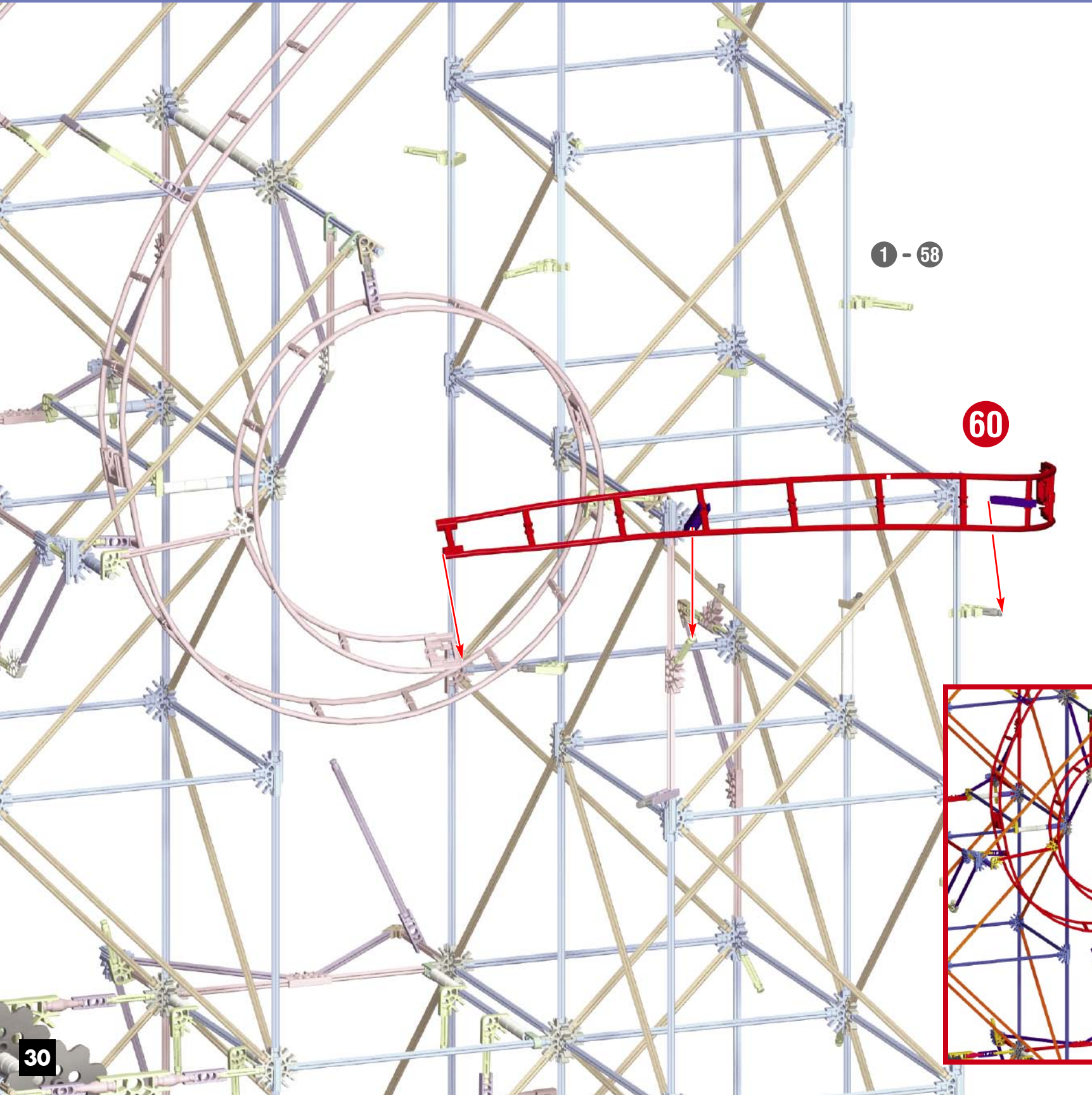
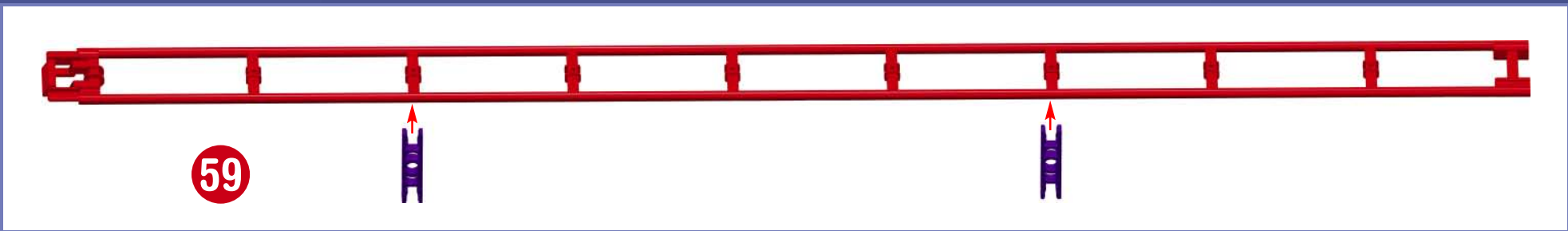

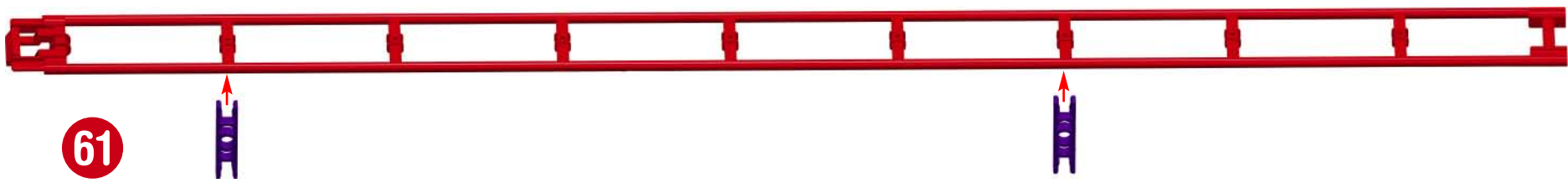

61

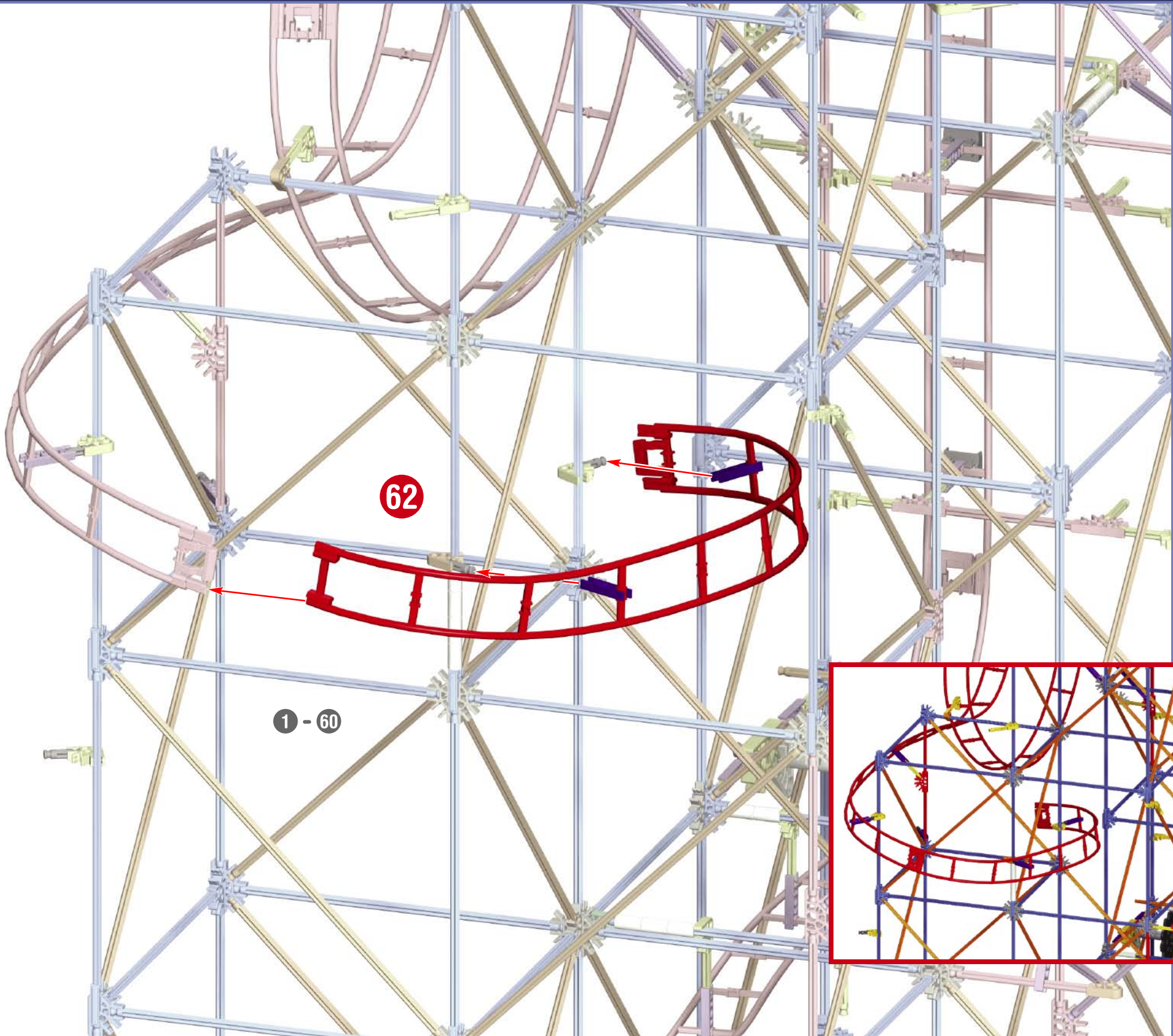

62

1 - 60

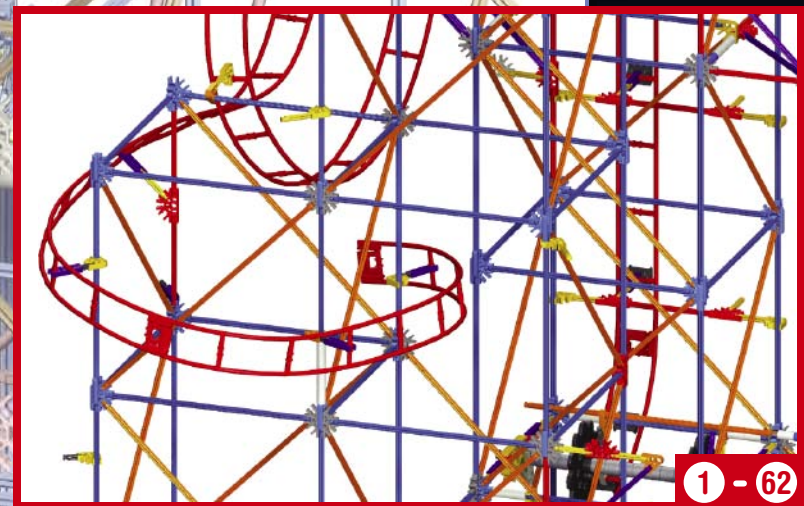

1 - 62

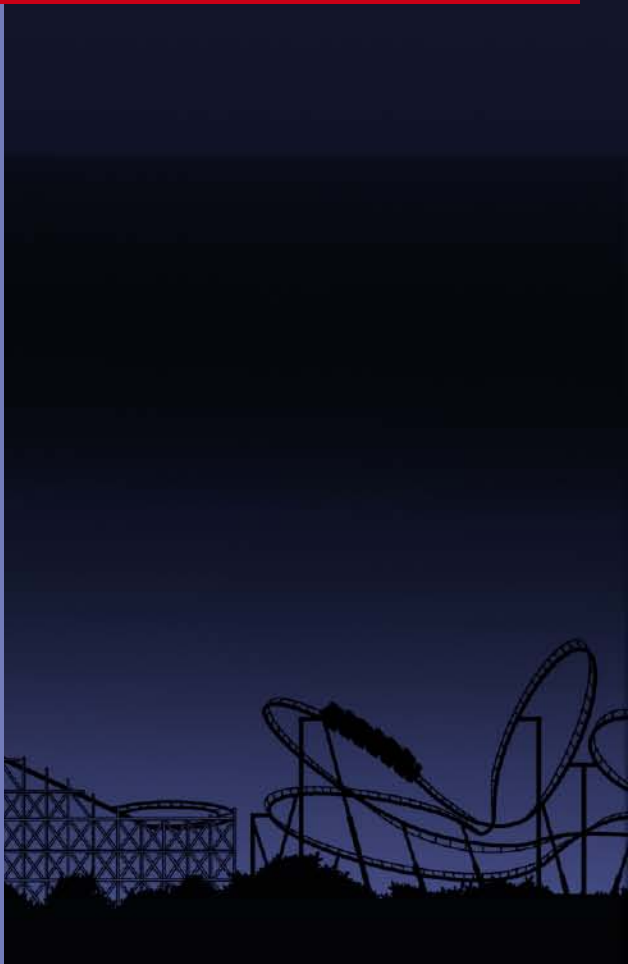
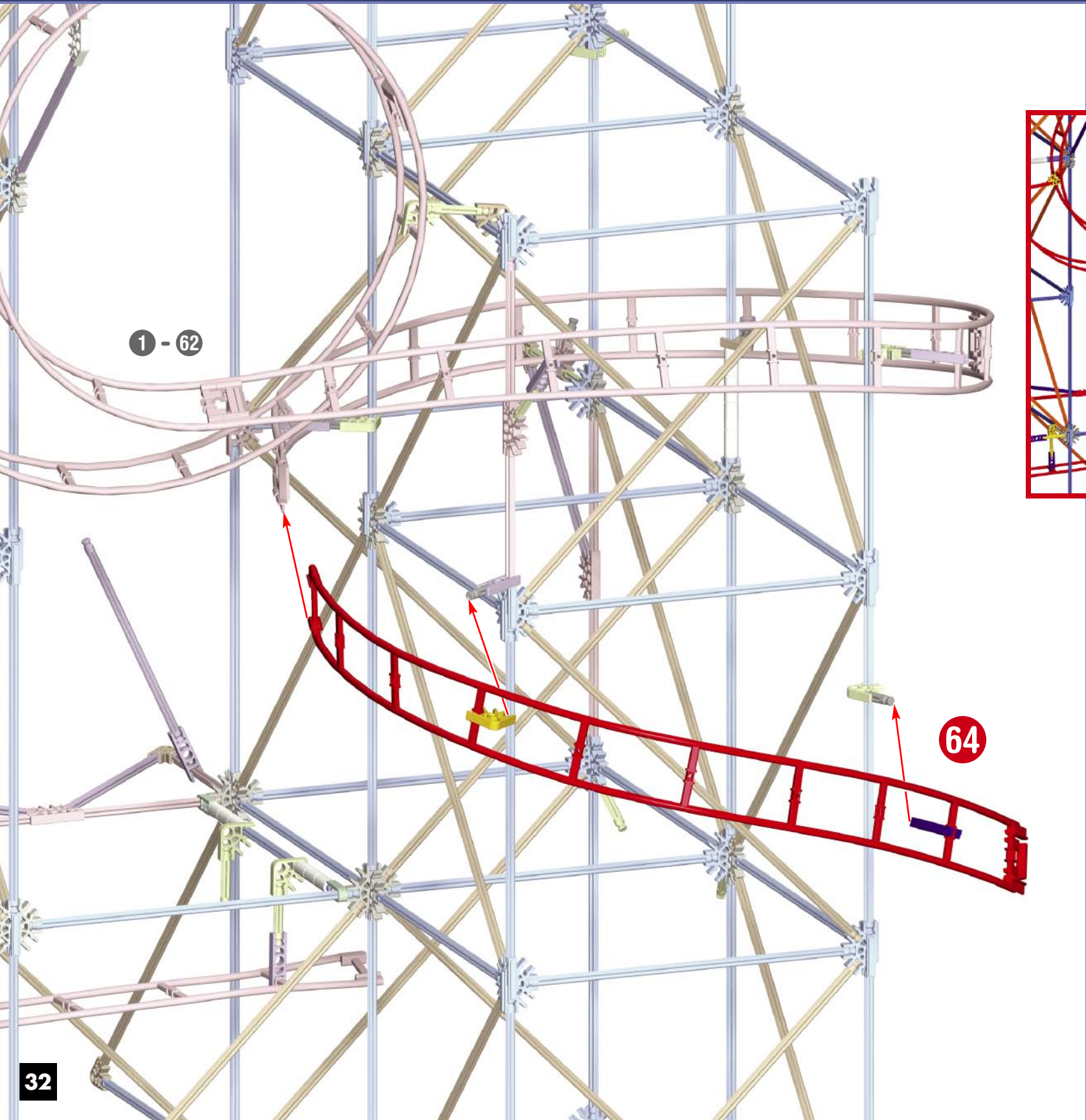
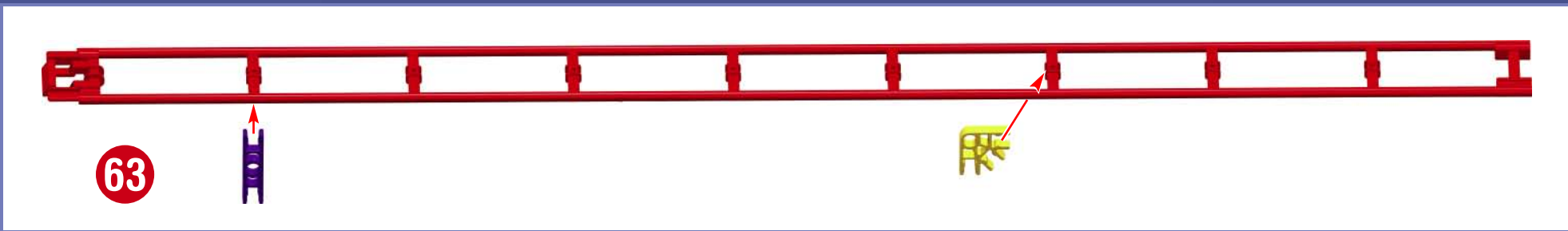



65



1 - 64

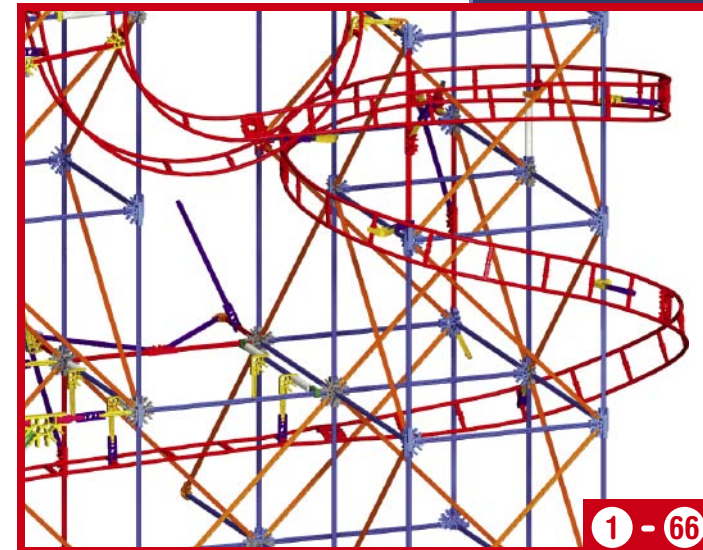

1 - 66

66



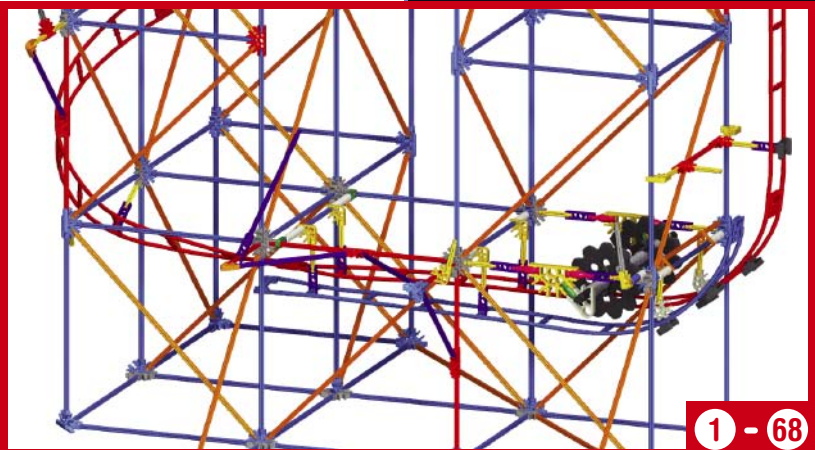
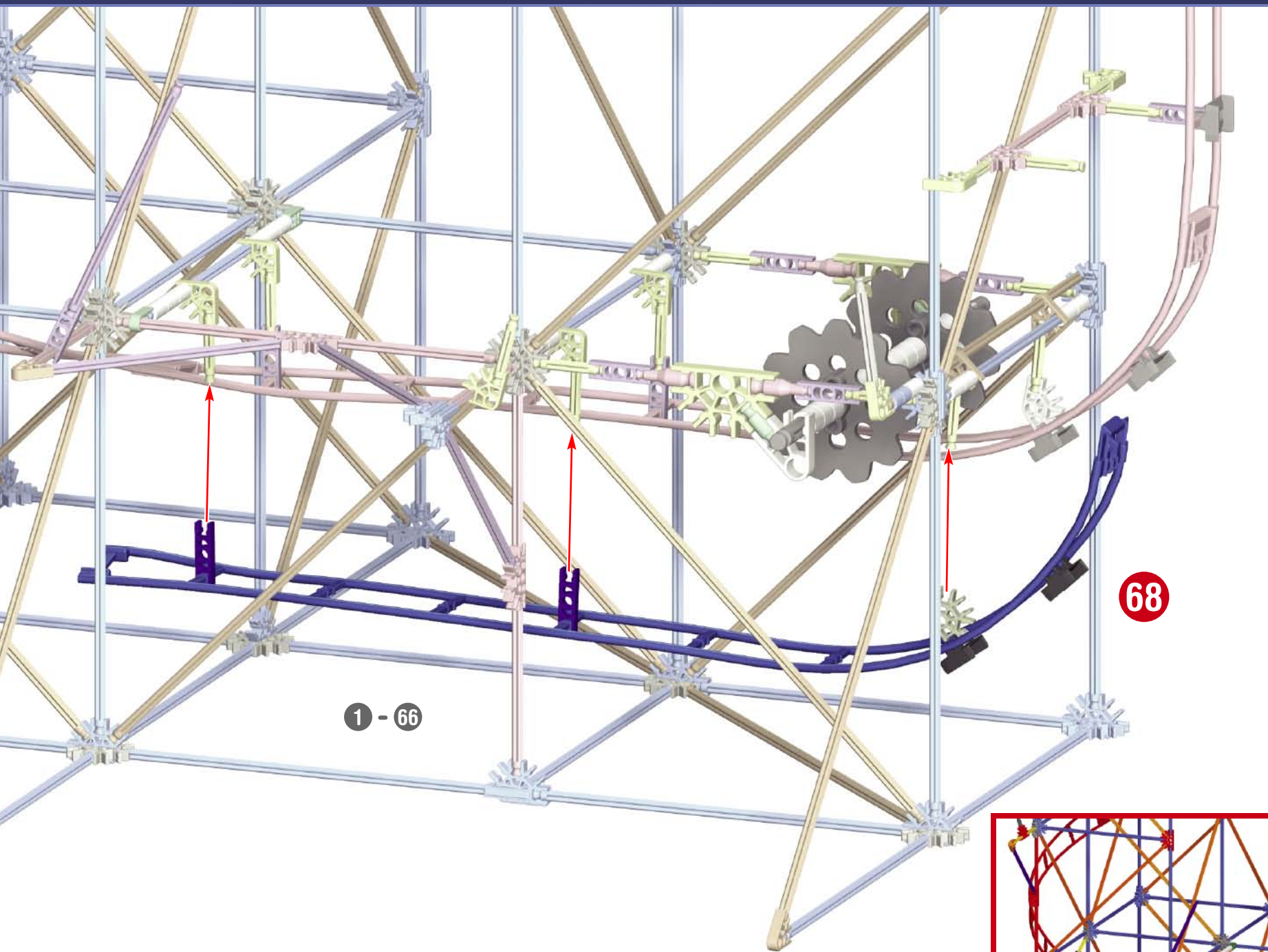
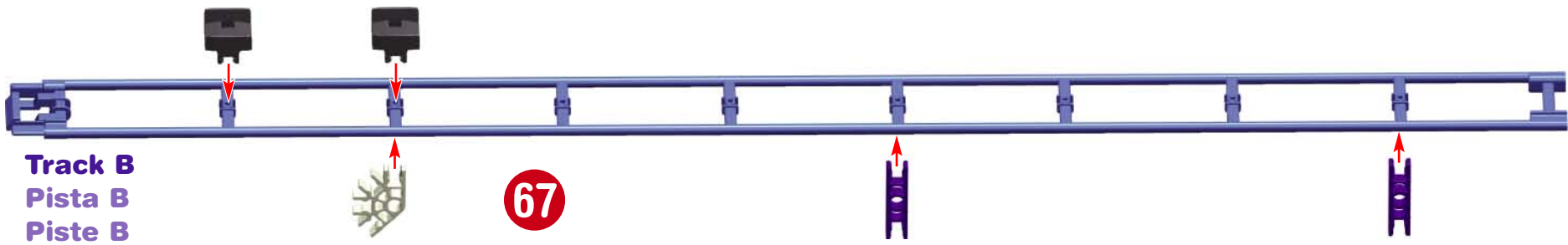

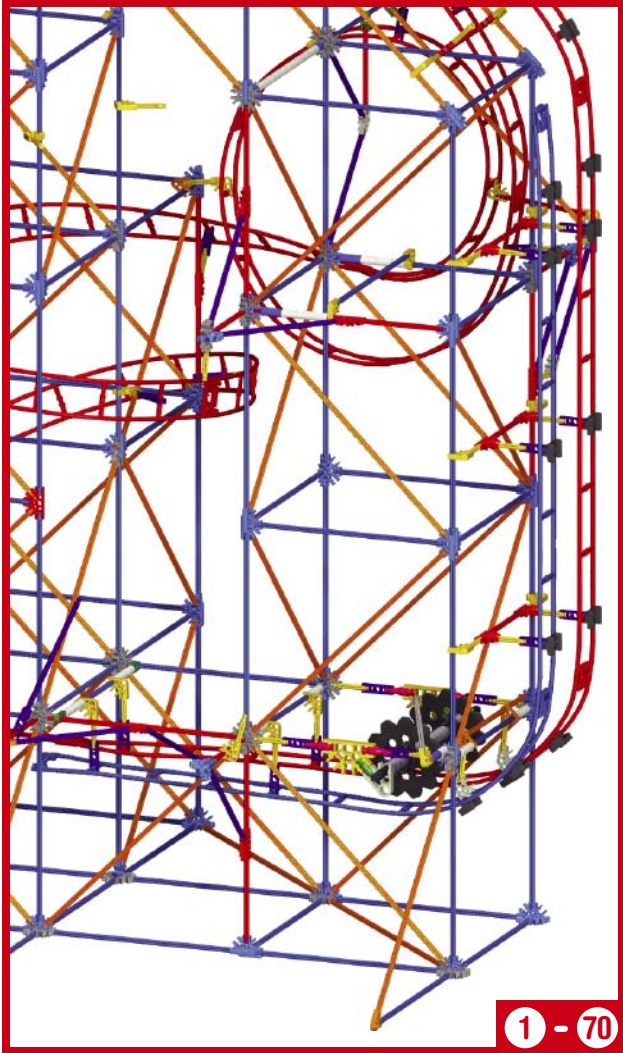
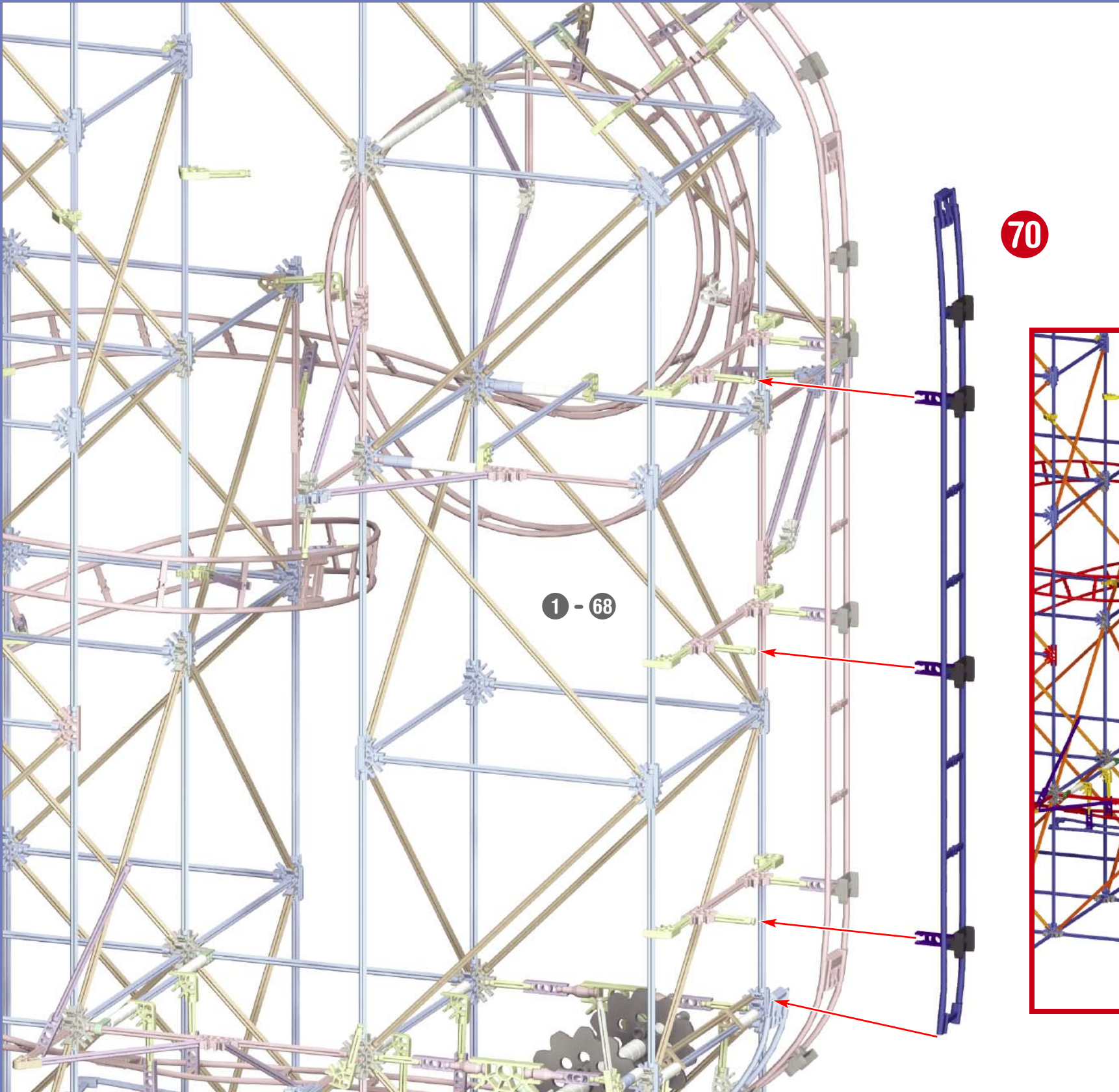
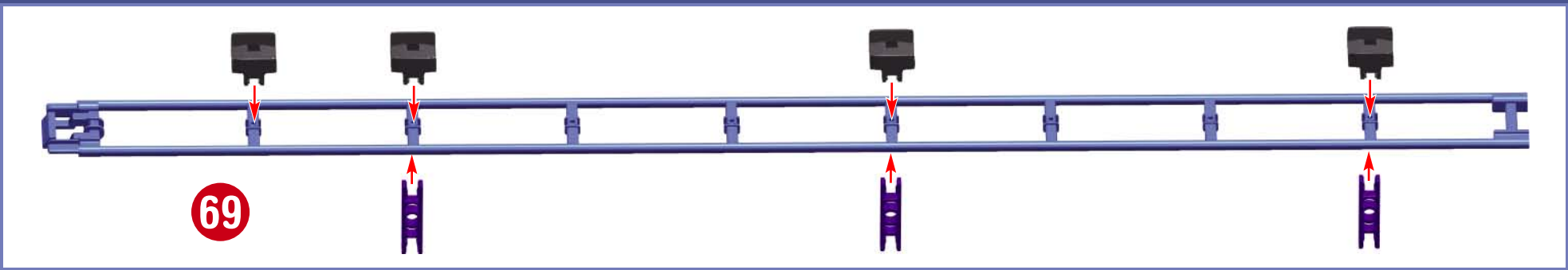

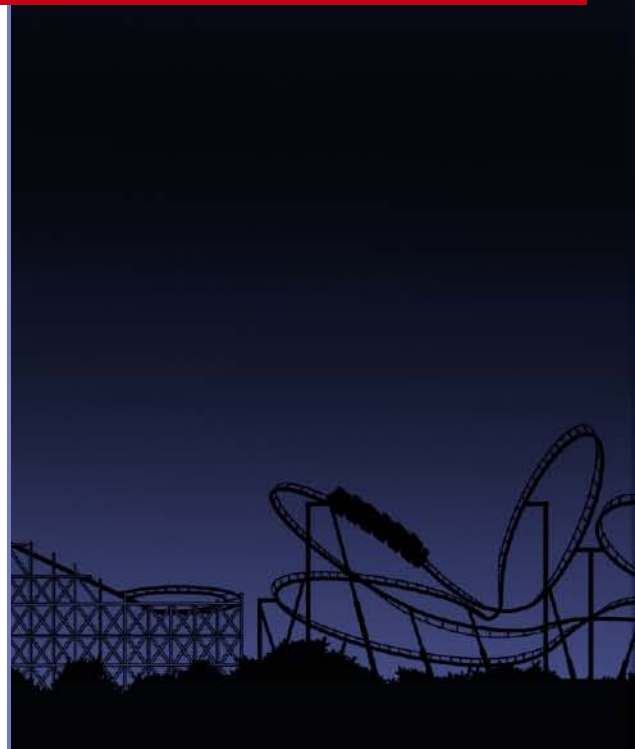
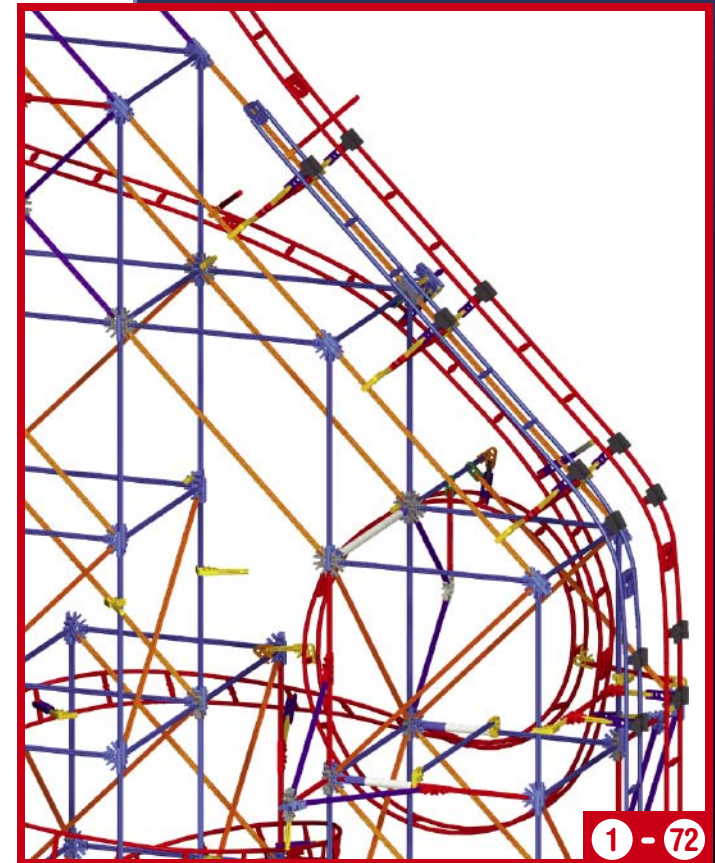
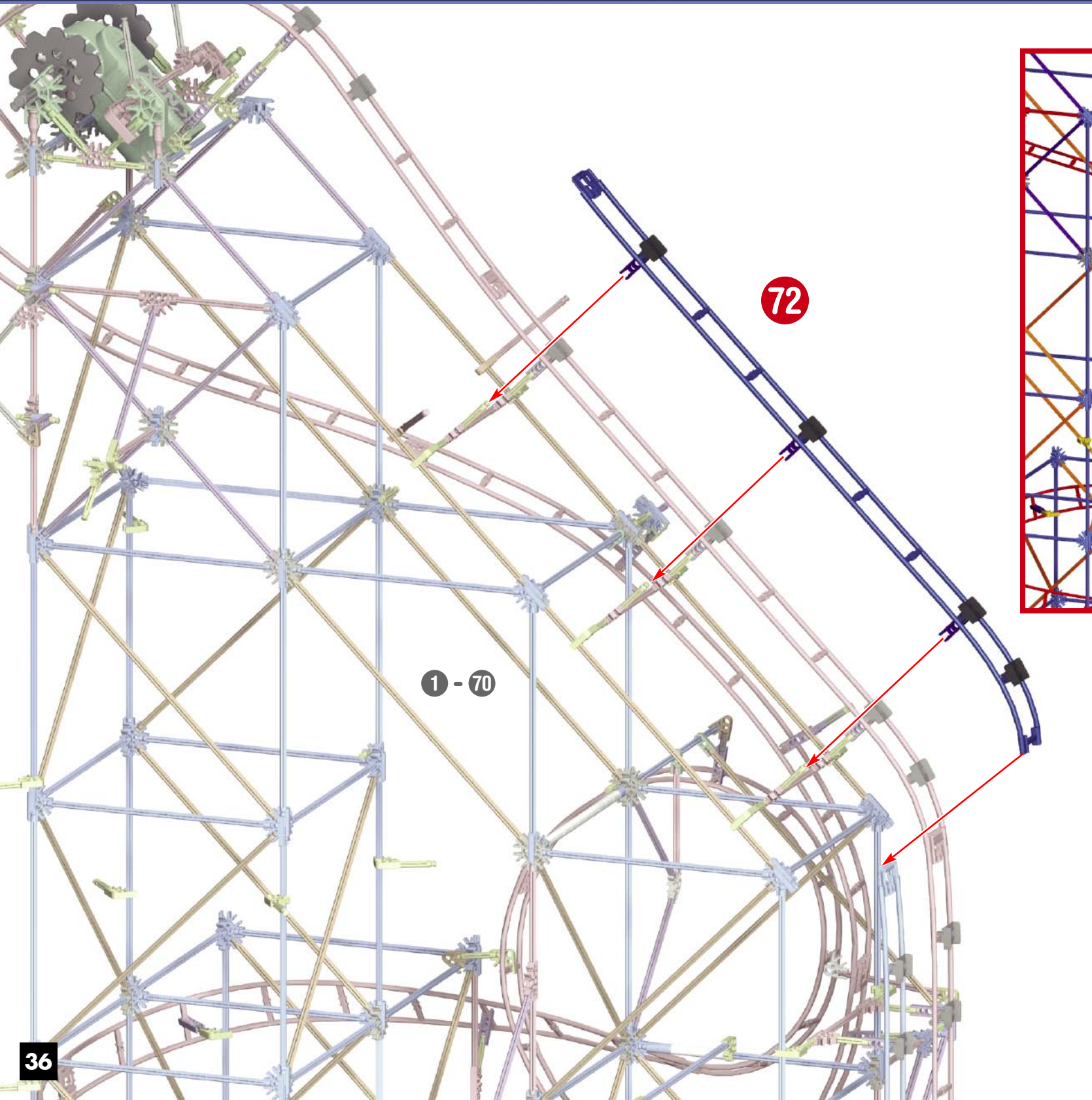
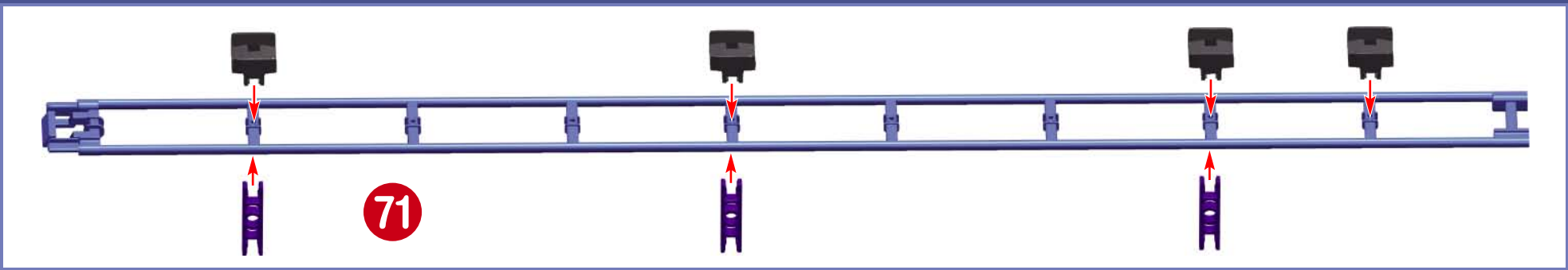

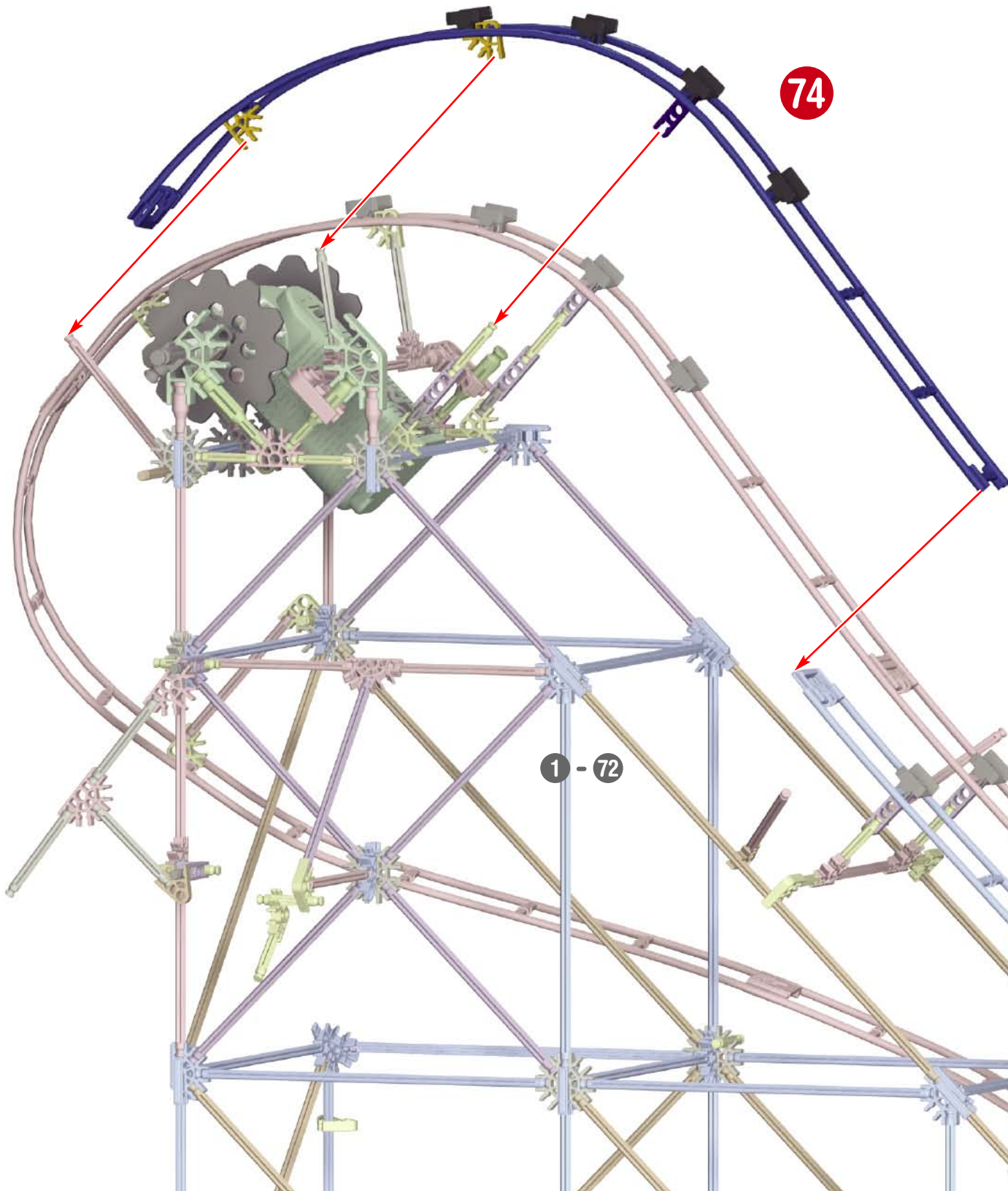
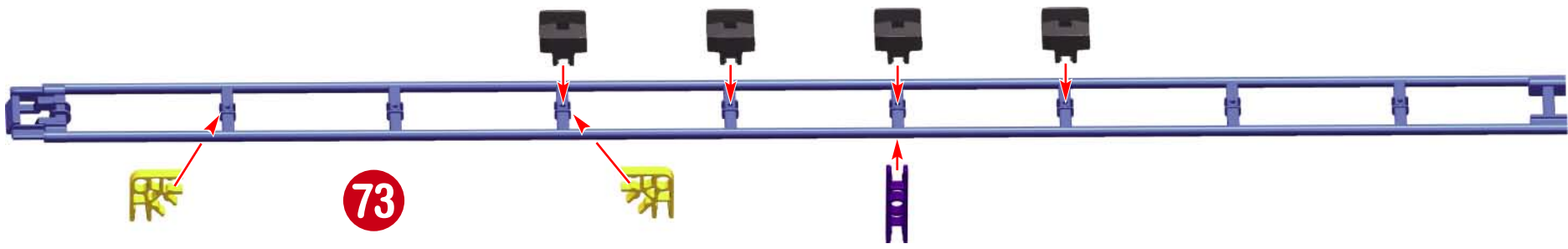

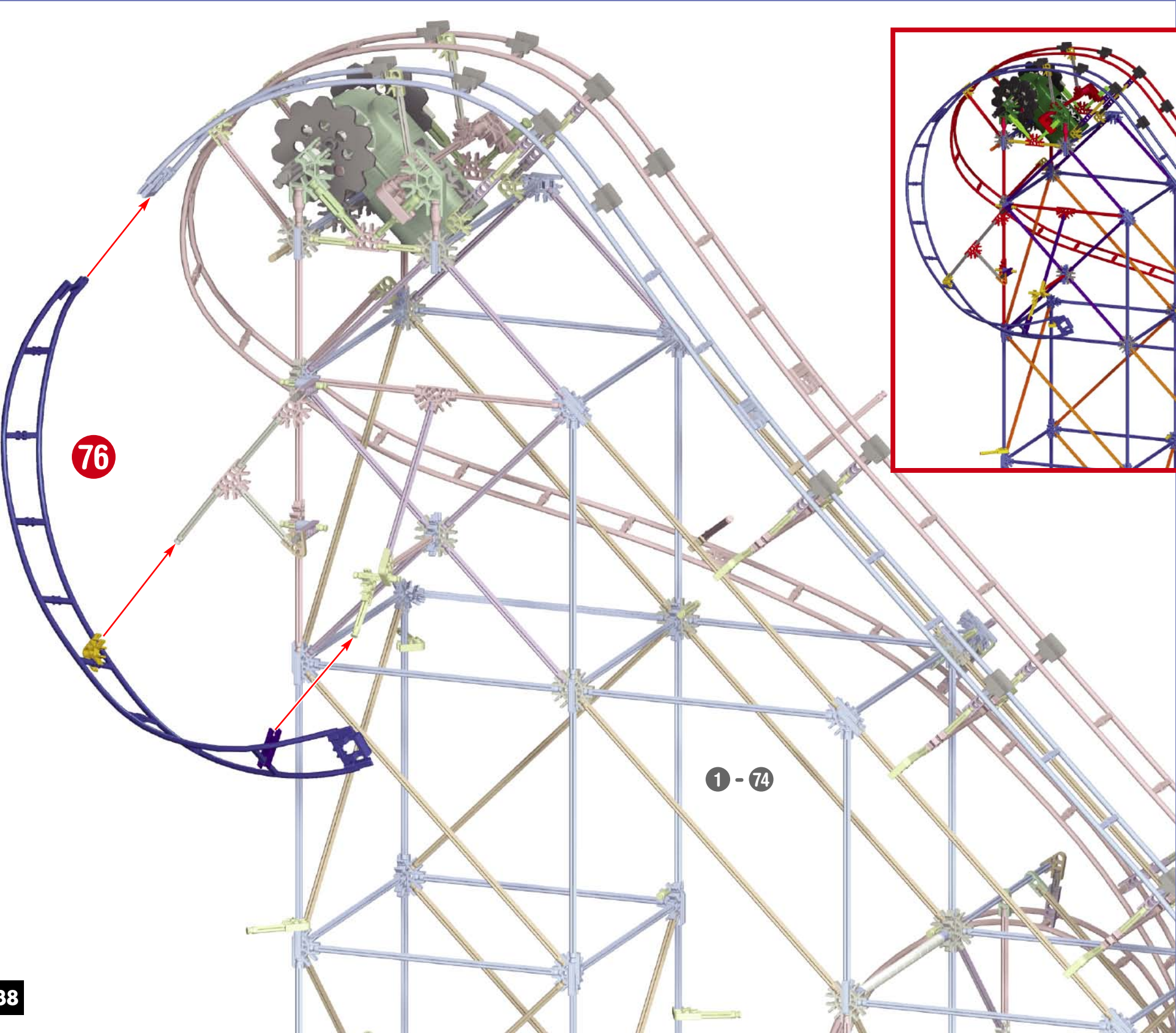
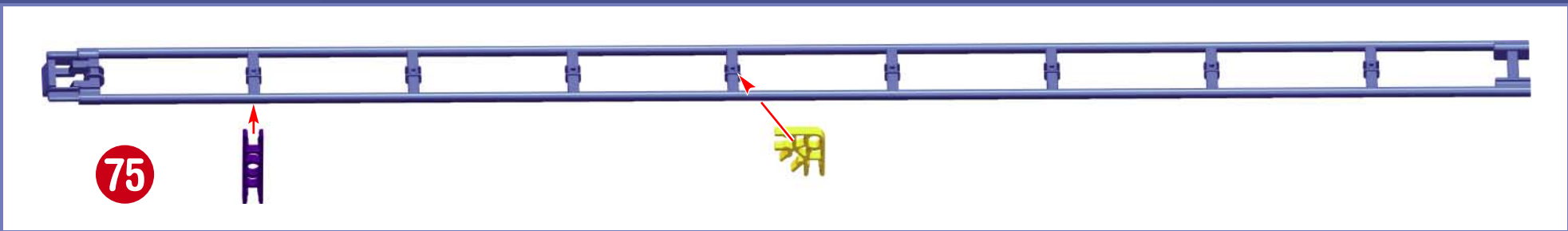



77

翔

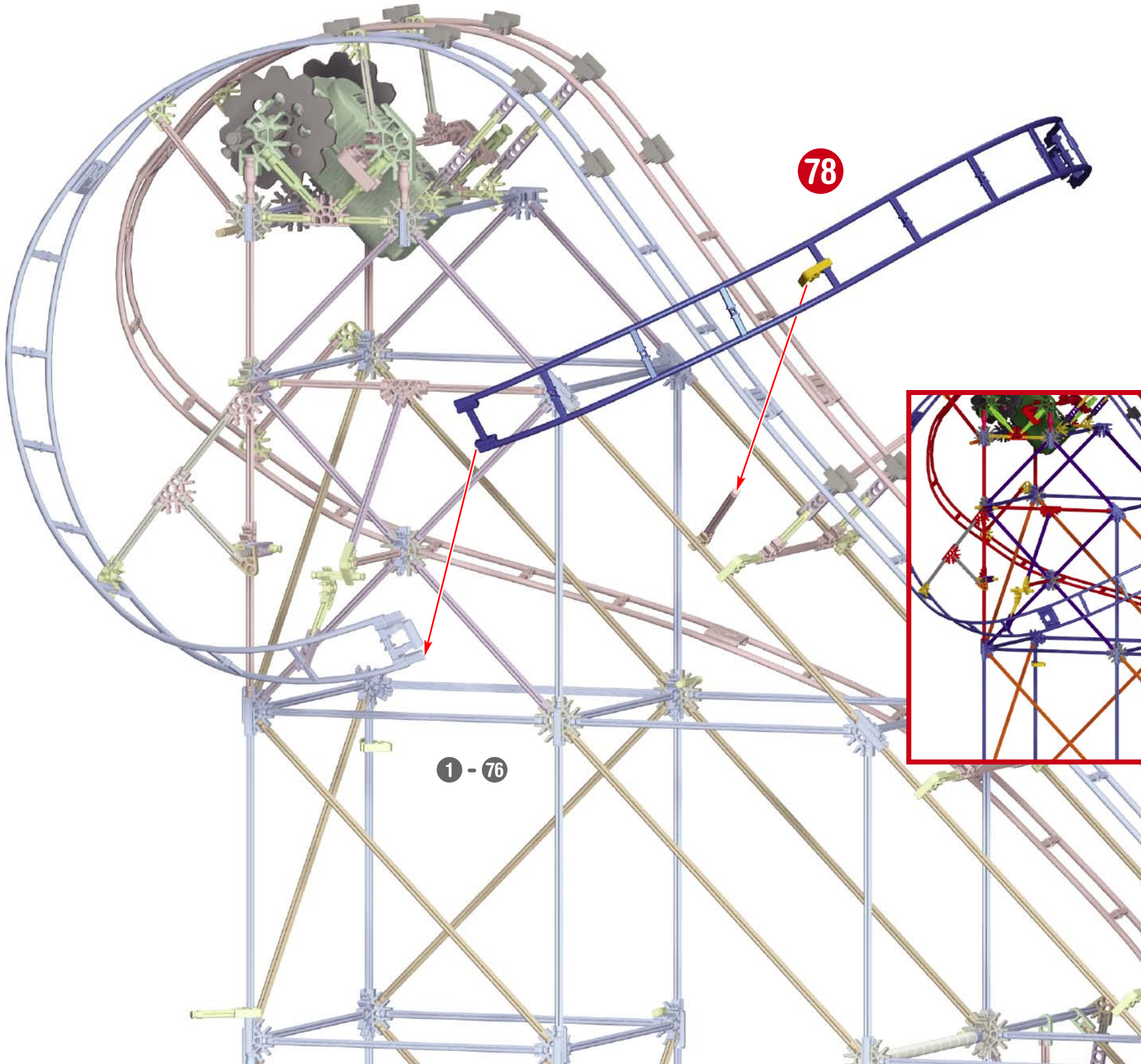

78

1 - 76

1 - 78



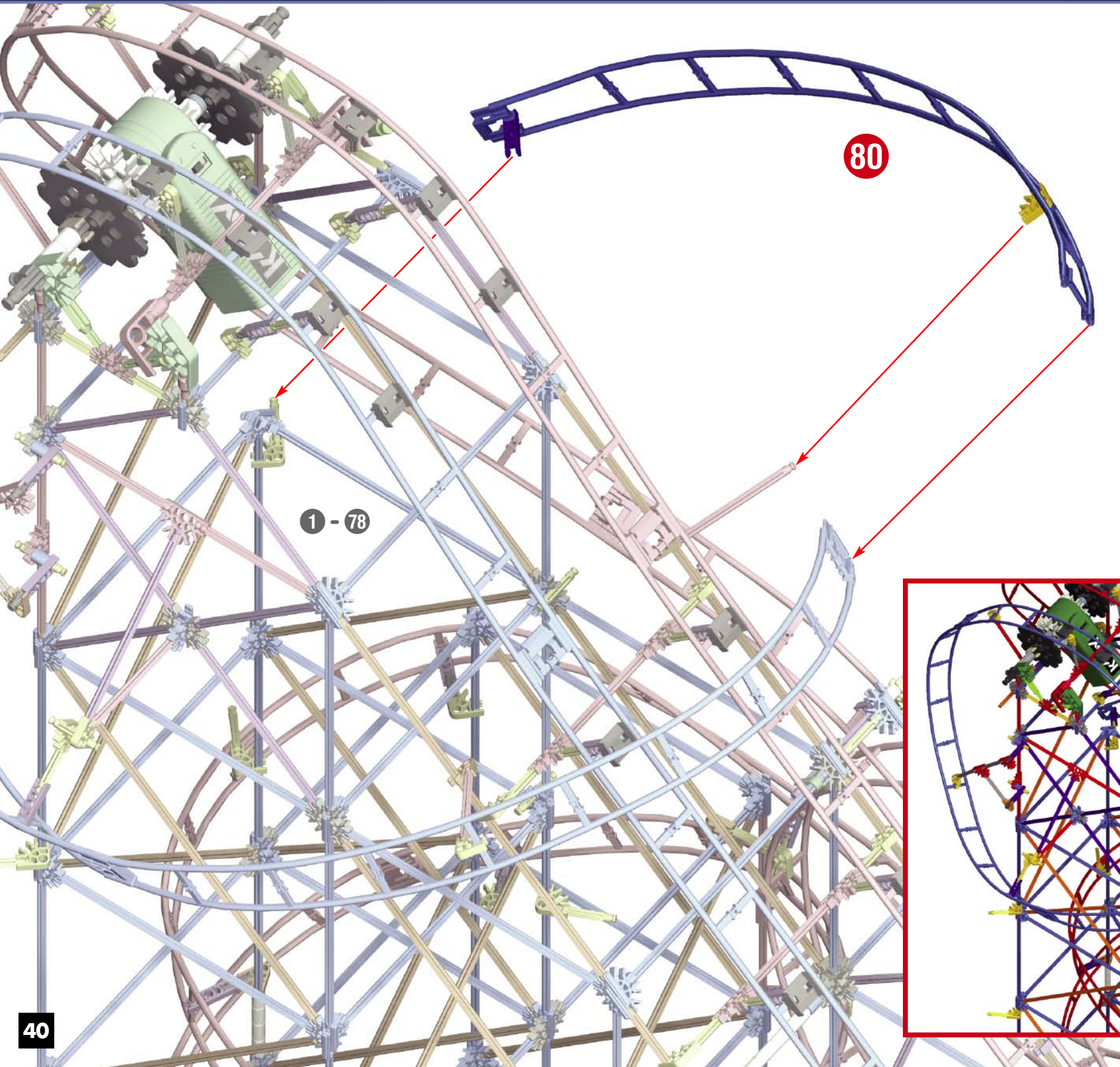
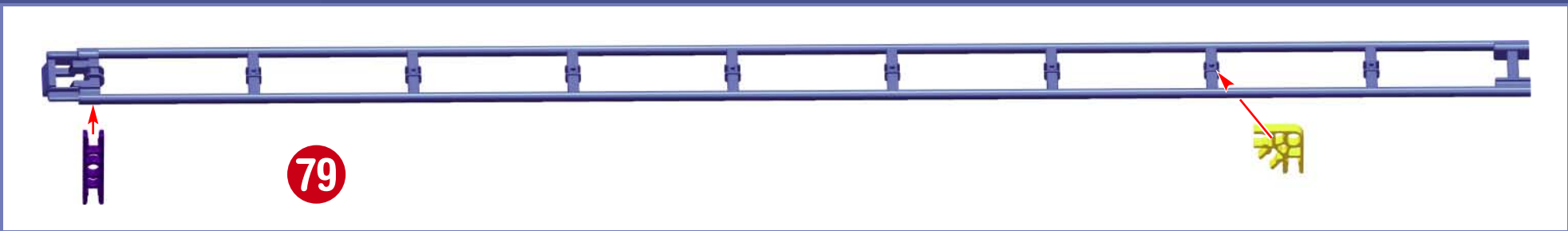



81

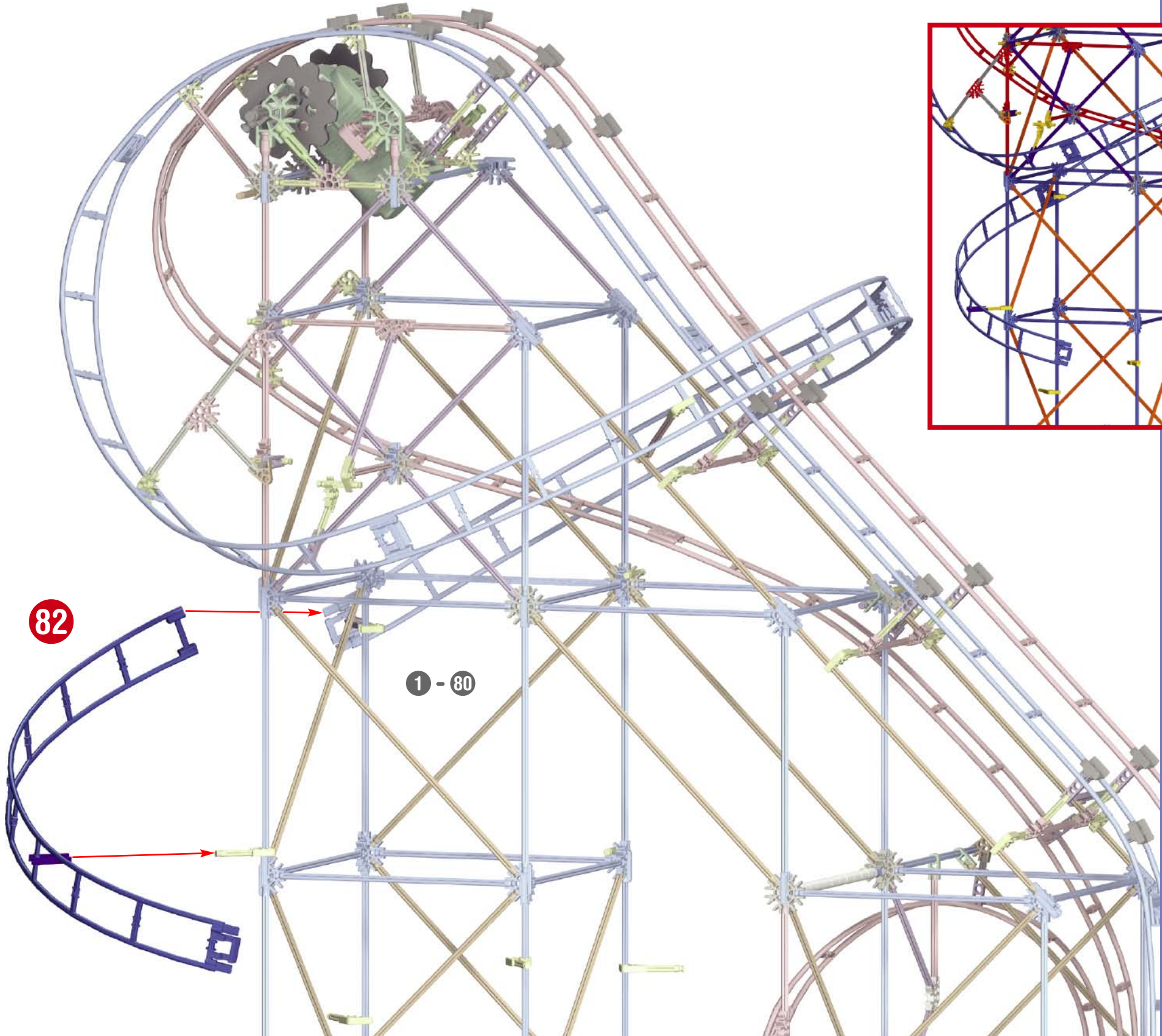

82

1 - 80

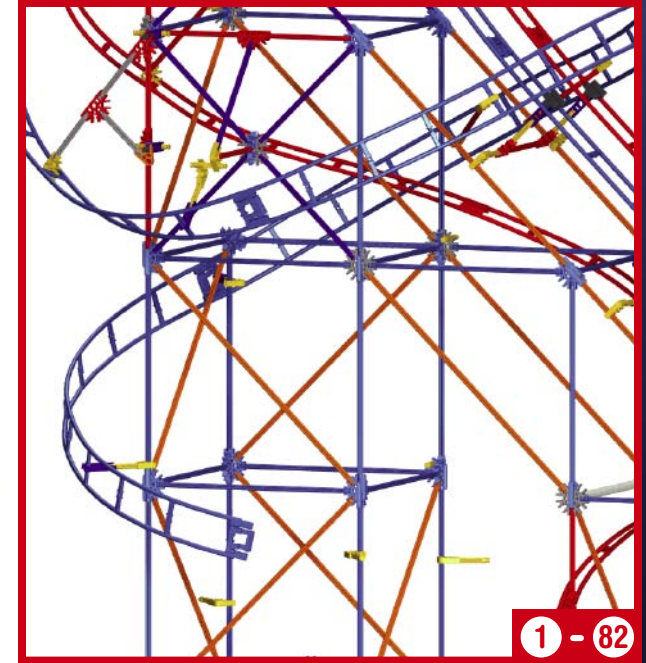

1 - 82



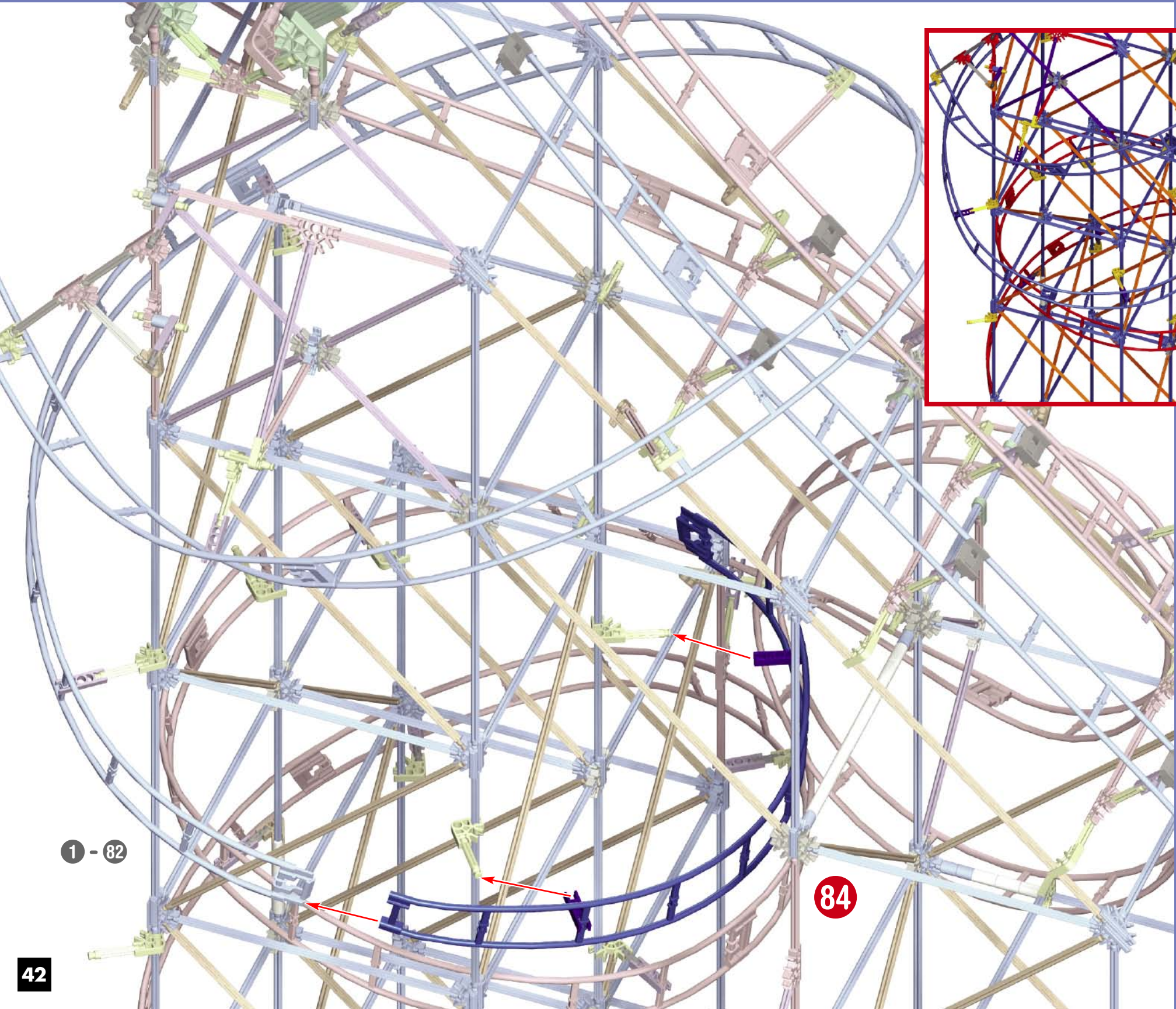

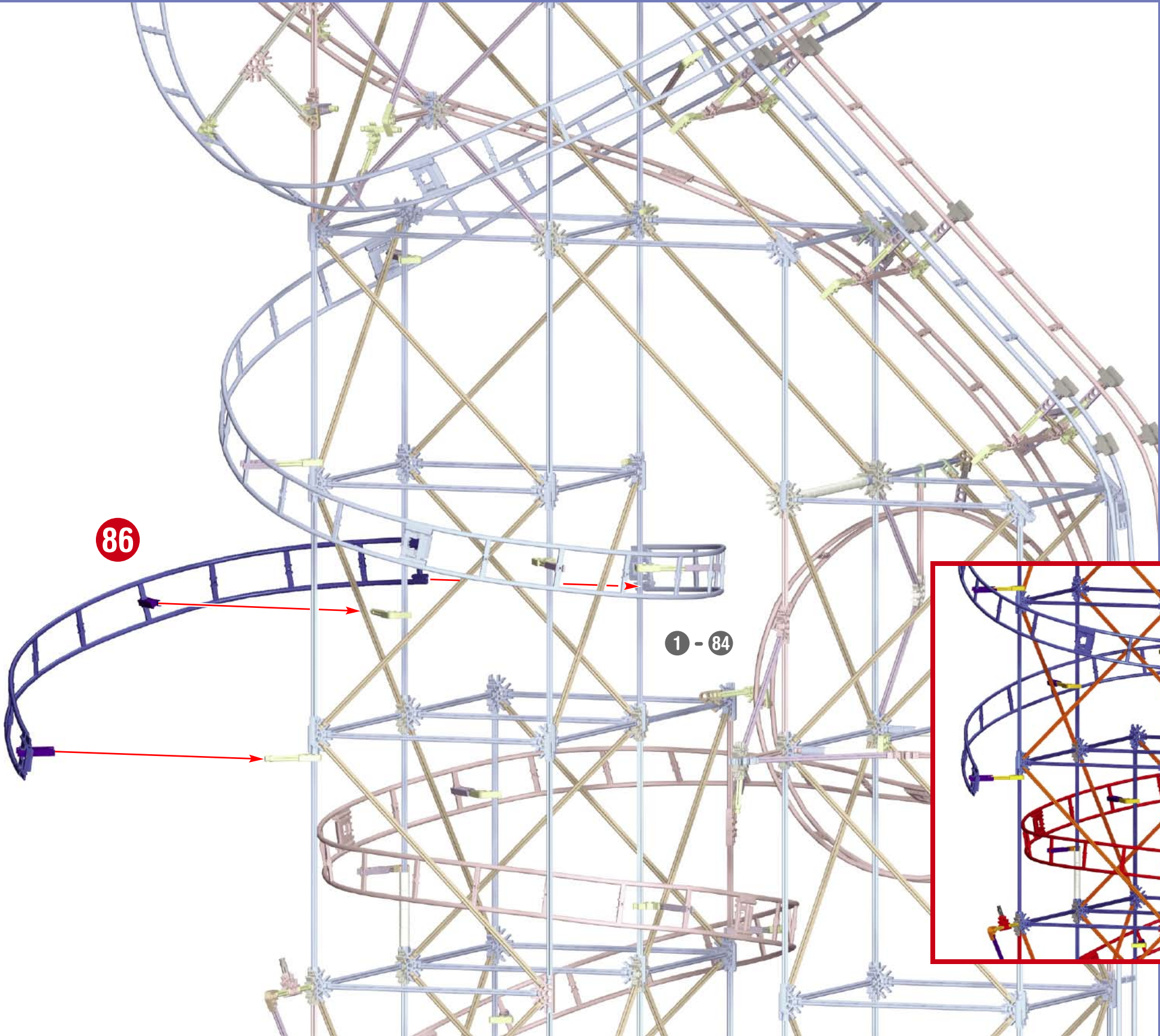



87

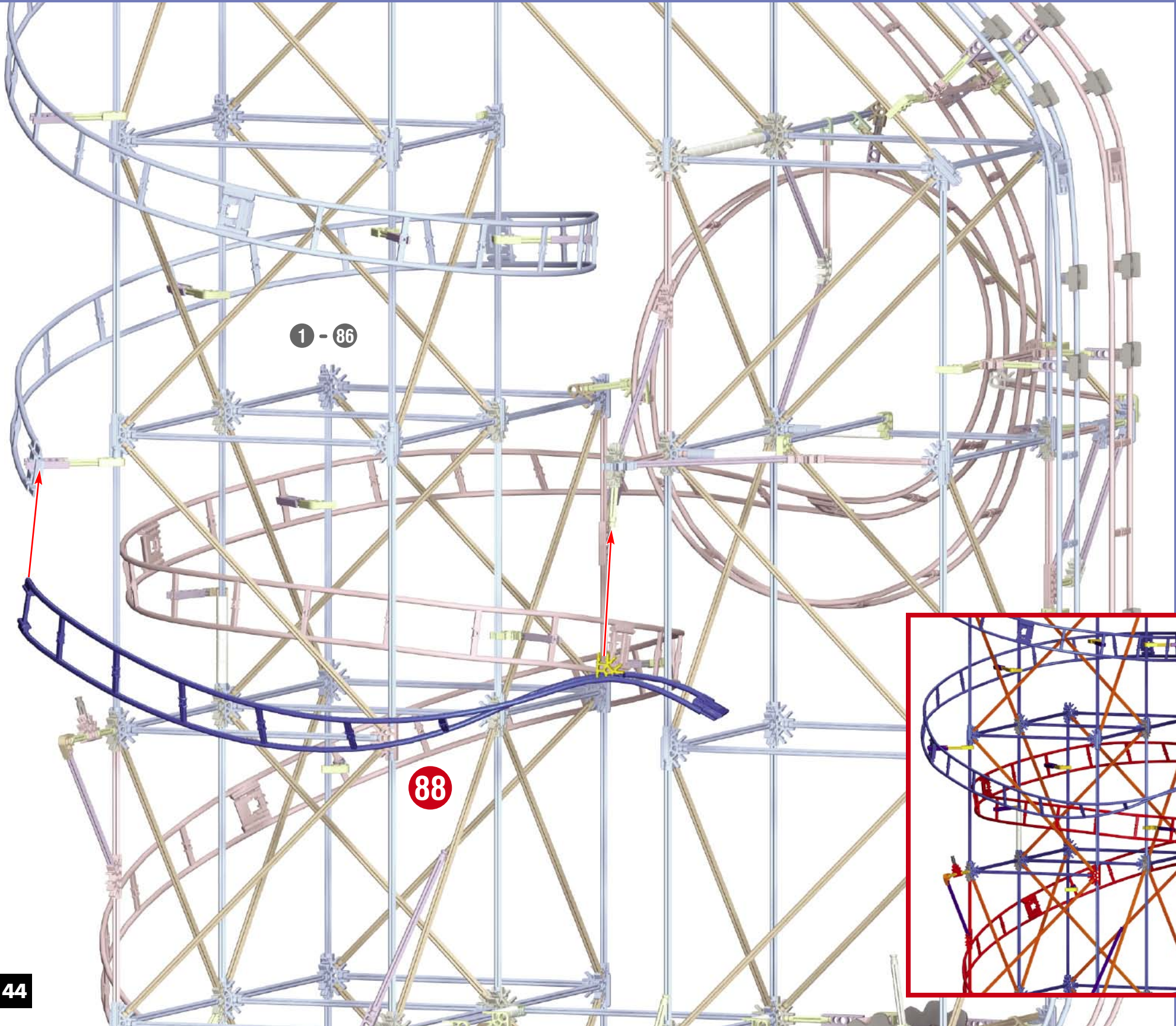

1 - 86

88

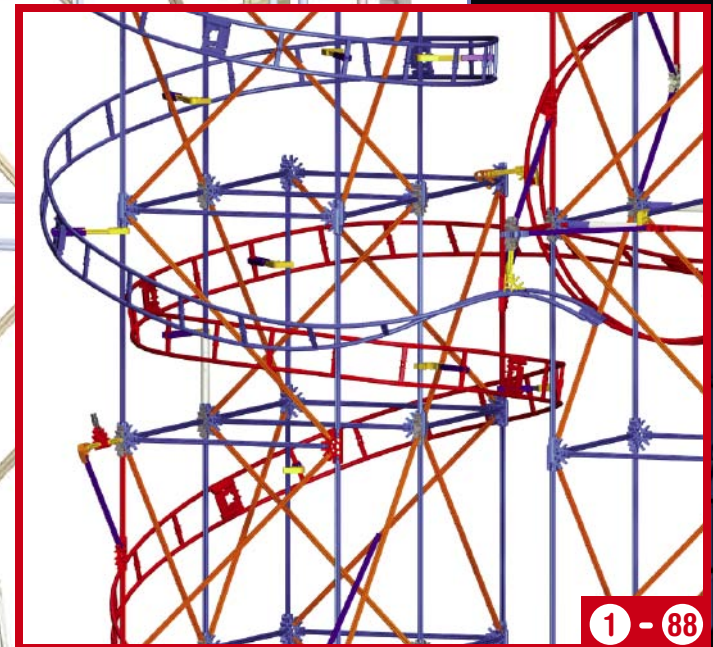

1 - 88

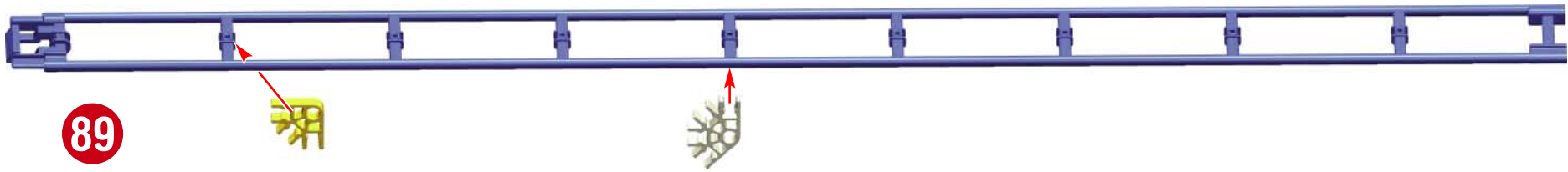

89

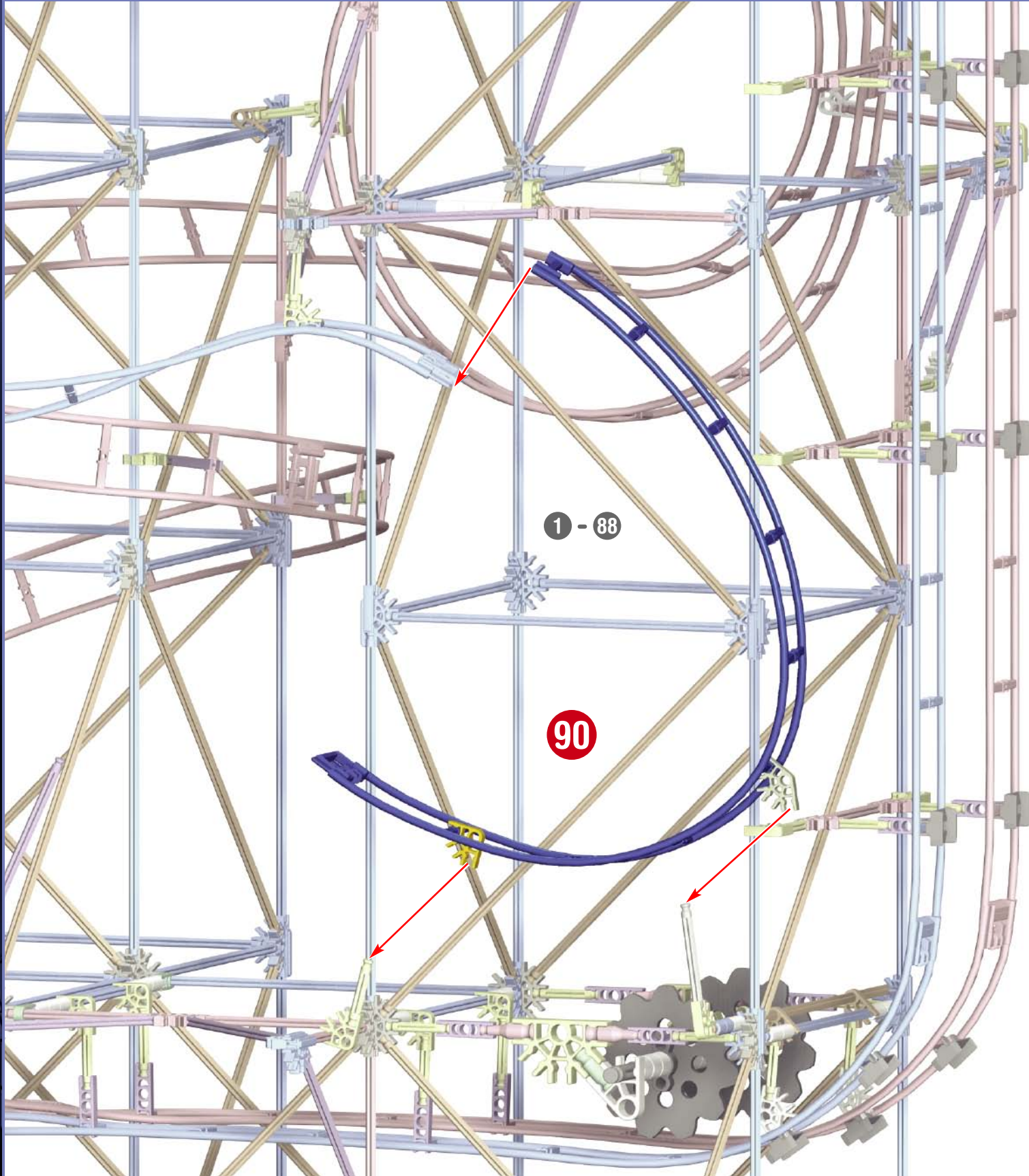

1 - 88

90

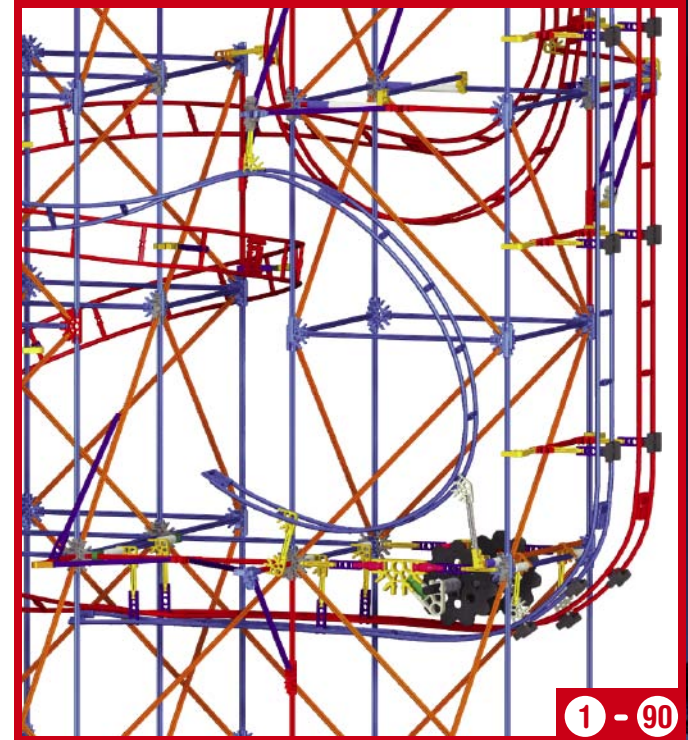

1 - 90

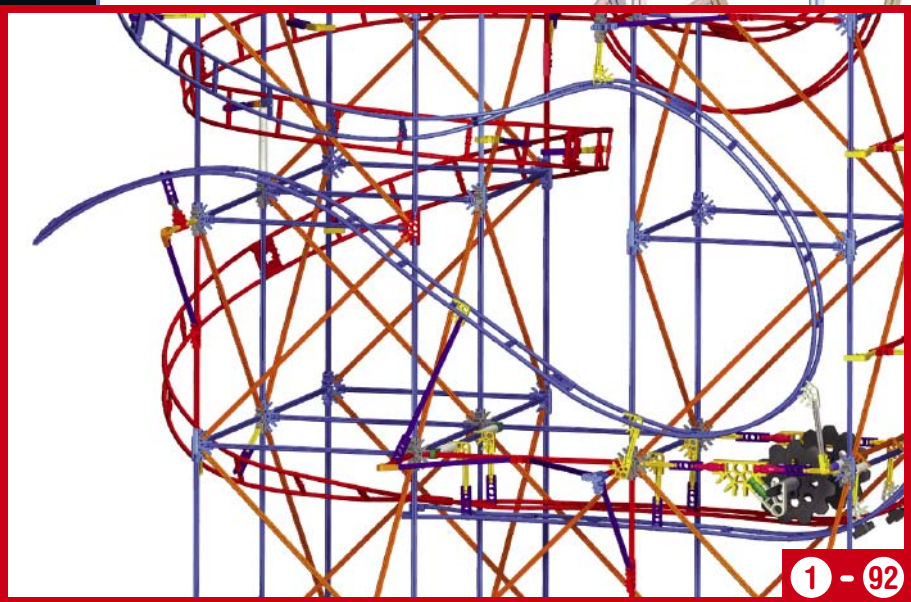
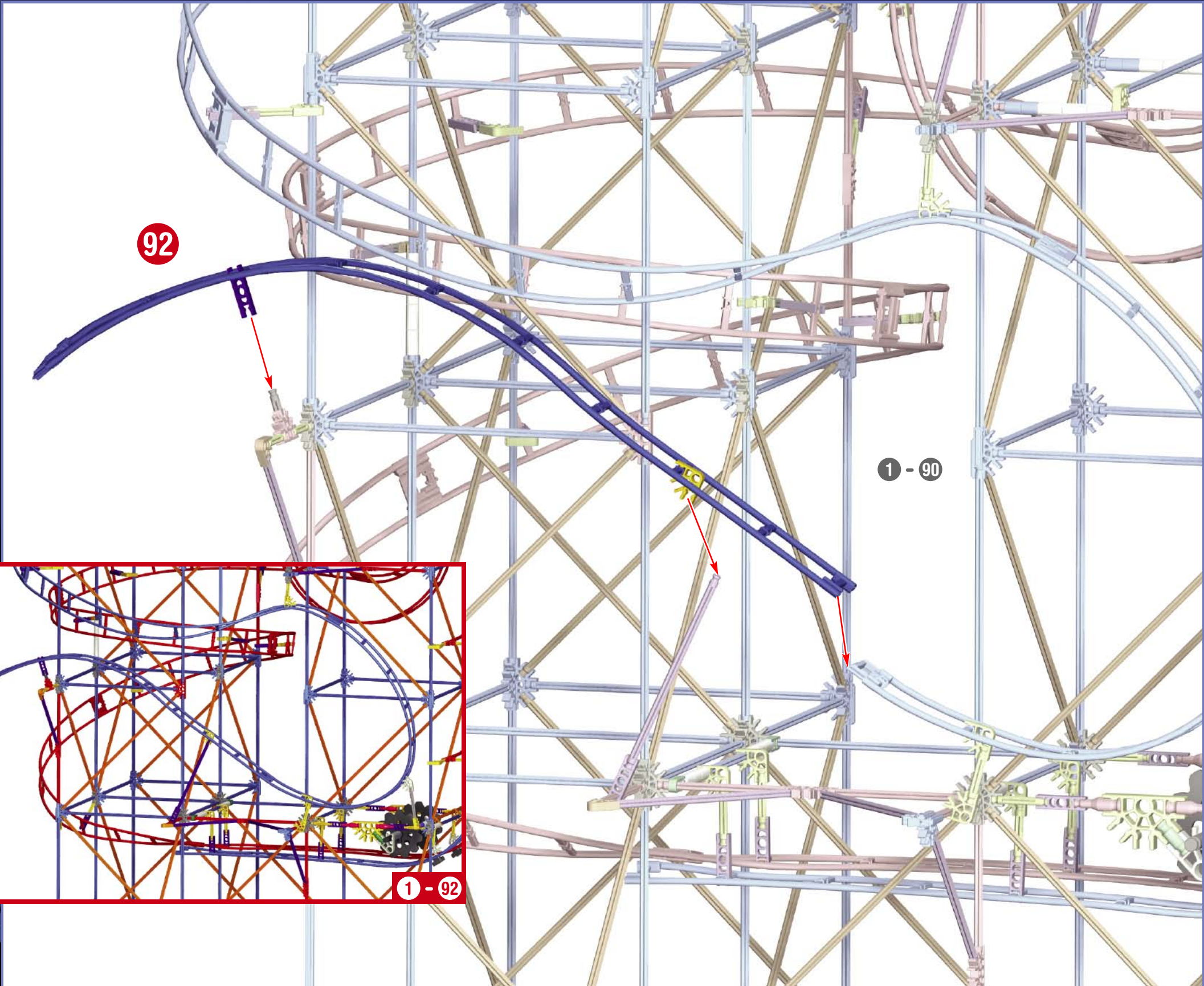



93

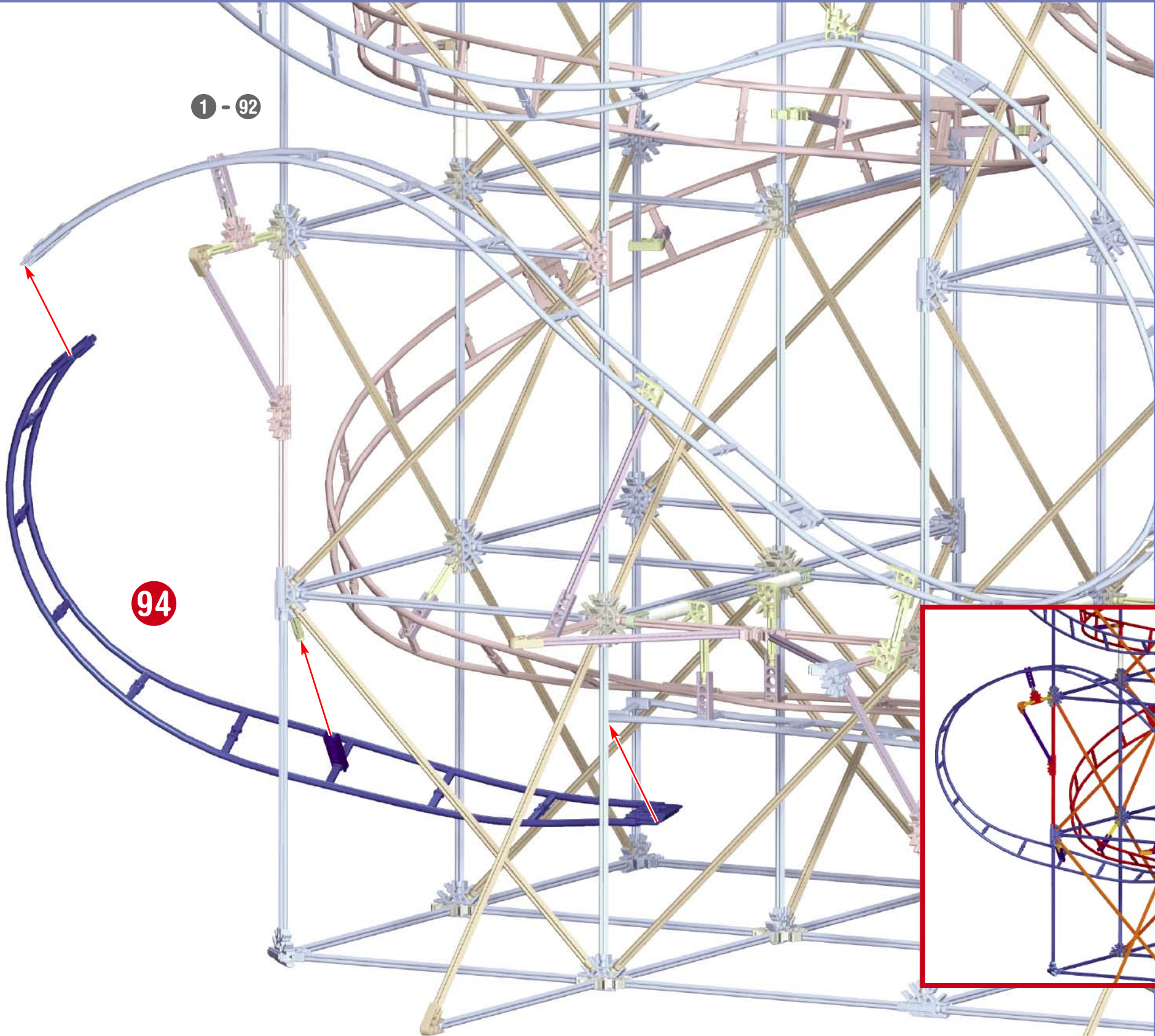

1 - 92

94

1 - 94



EN IMPORTANT: Attach all the chain links in the same direction.

ES IMPORTANTE: Conecta los Eslabones de la Cadena en la misma dirección.

FR IMPORTANT : Attache les chaînons dans le même sens.

DE WICHTIG: Befestige die Kettenglieder immer in die gleiche Richtung.

IT IMPORTANTE: Collegare le maglie della catena nella stessa direzione.

PT IMPORTANTE: Prende os Elos da Corrente seguindo a mesma direção.

NL BELANGRIJK: Maak de ketenschakels vast in dexelfde richting.

x32

95

x10



x2

96

x7



97

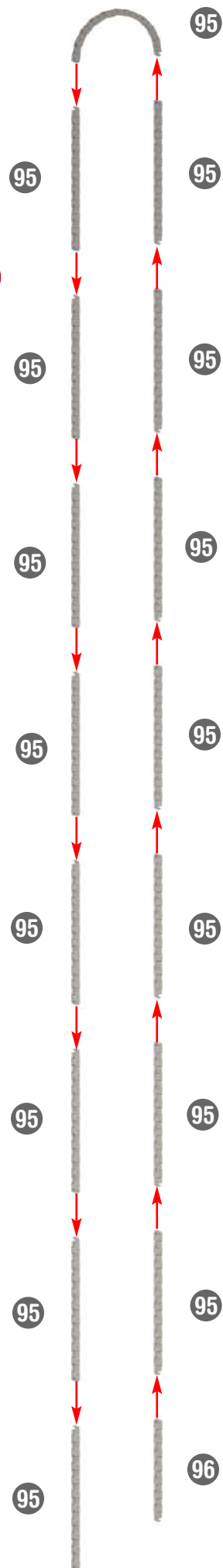

98

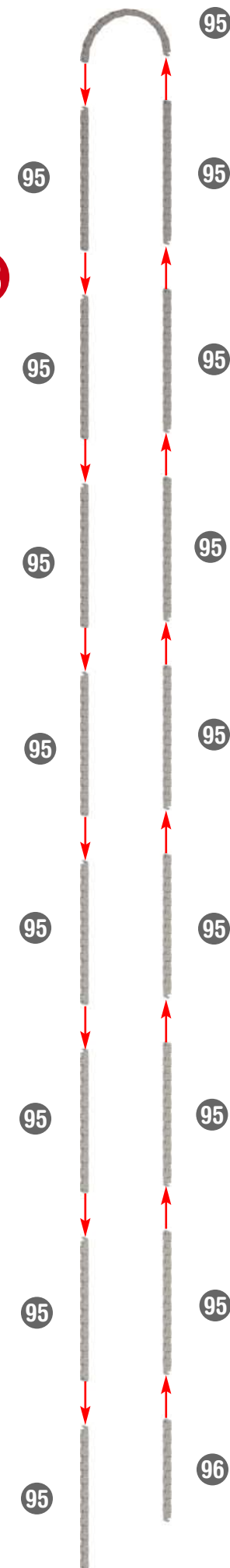

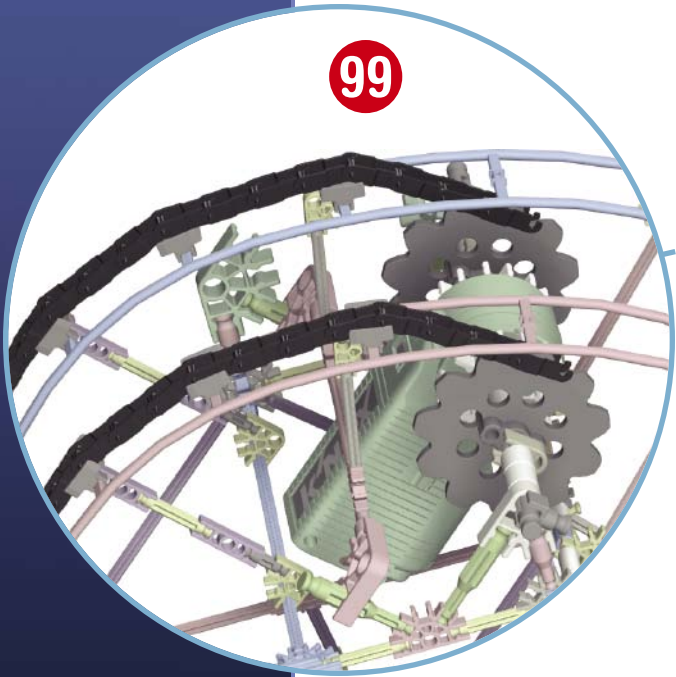

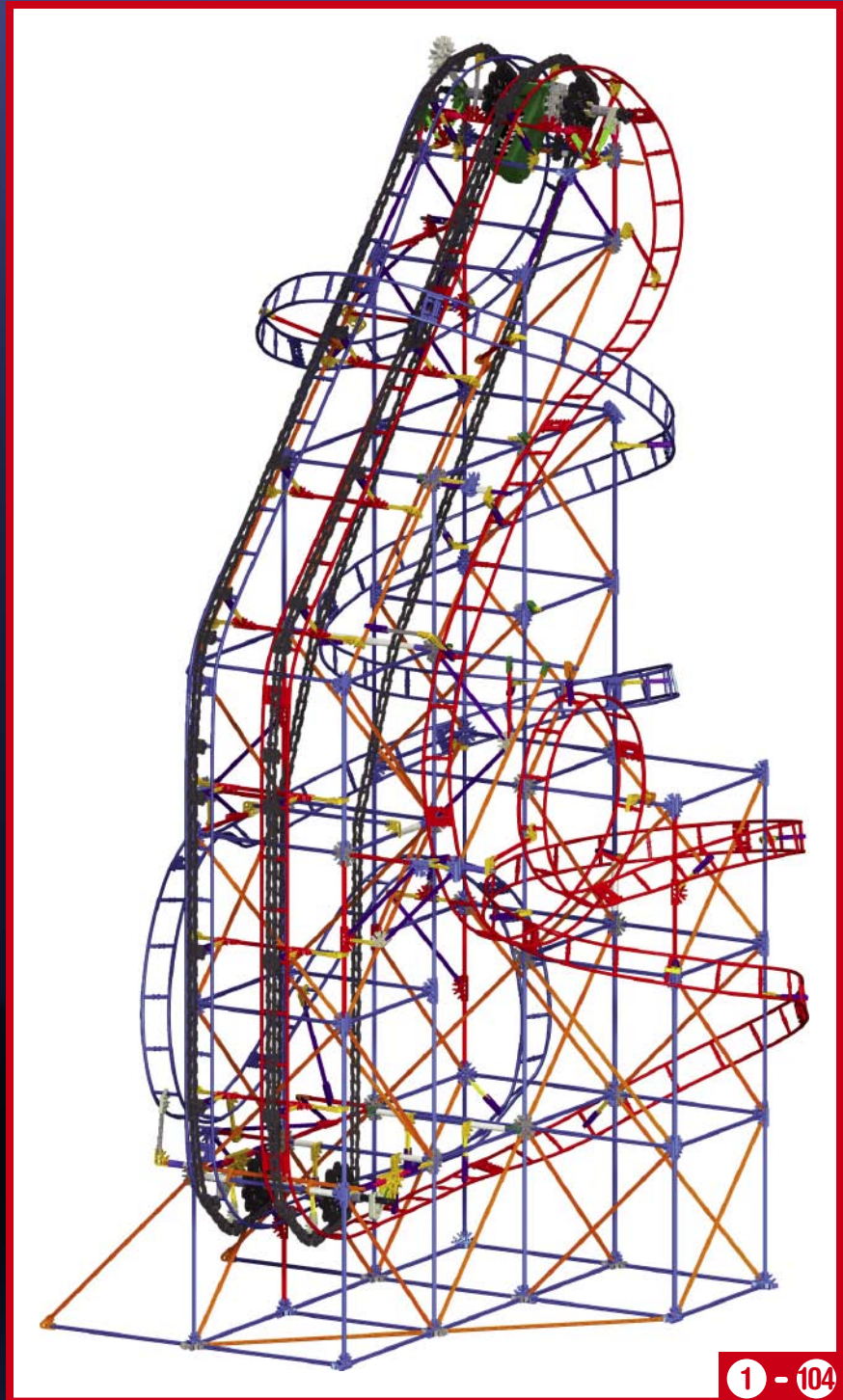
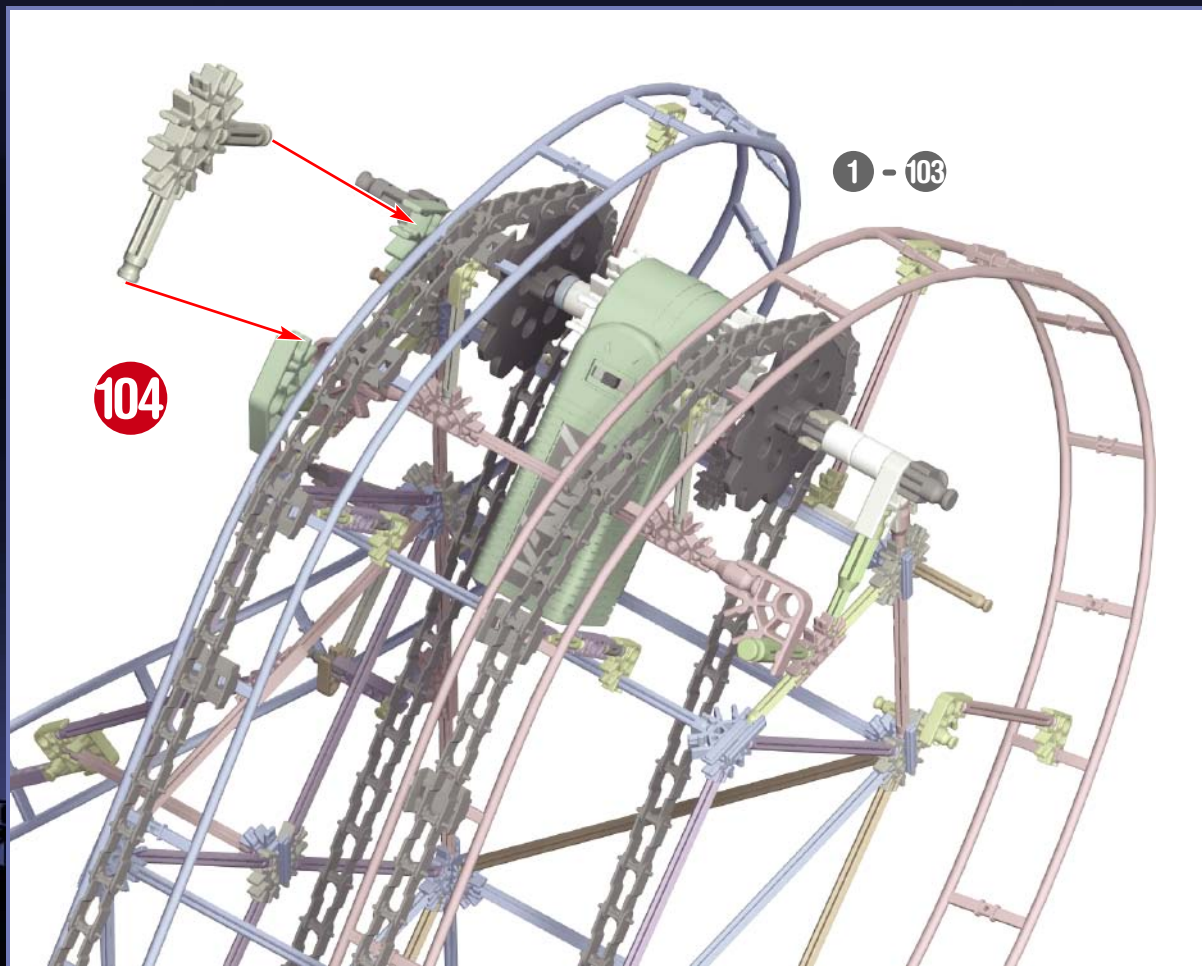
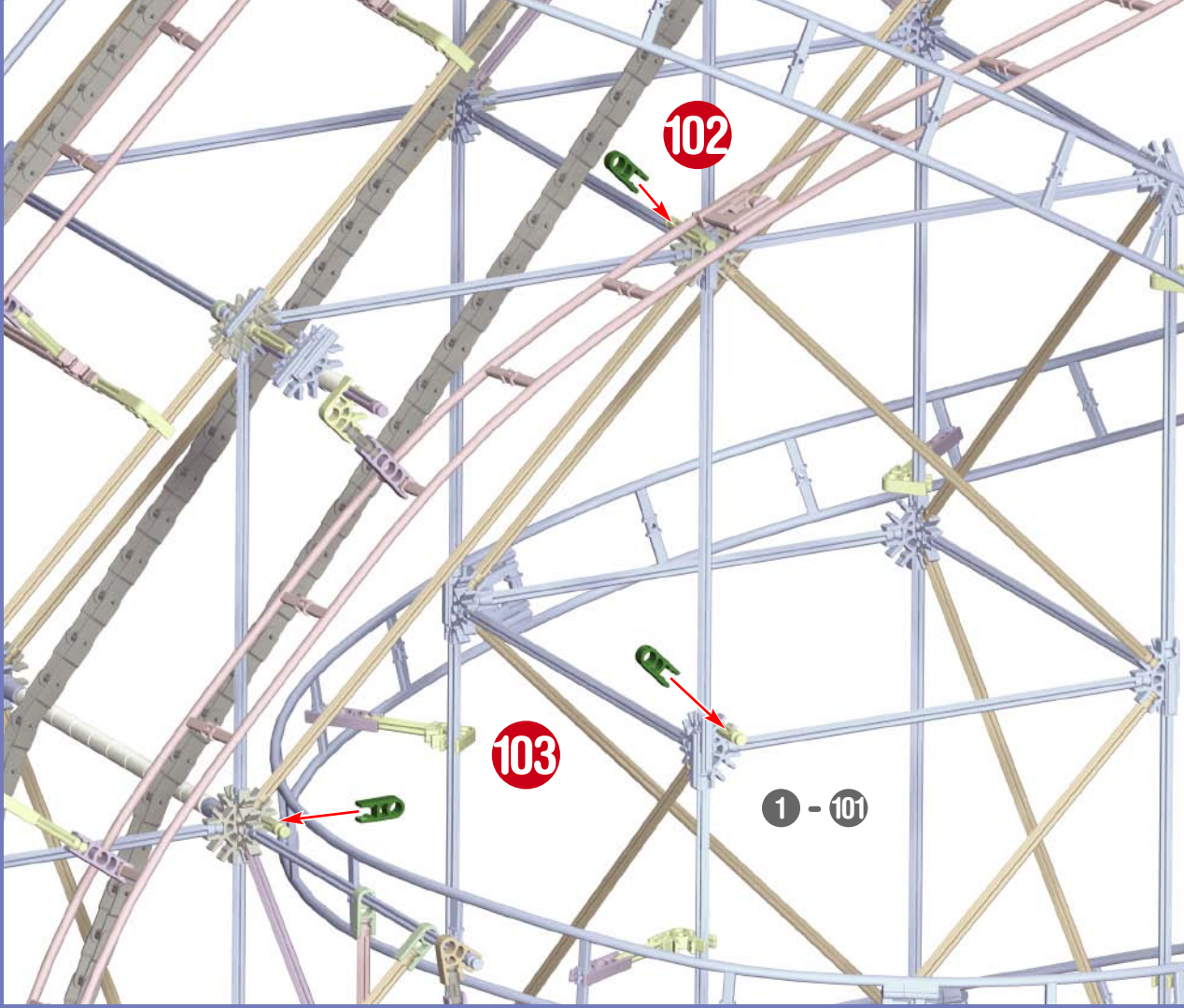

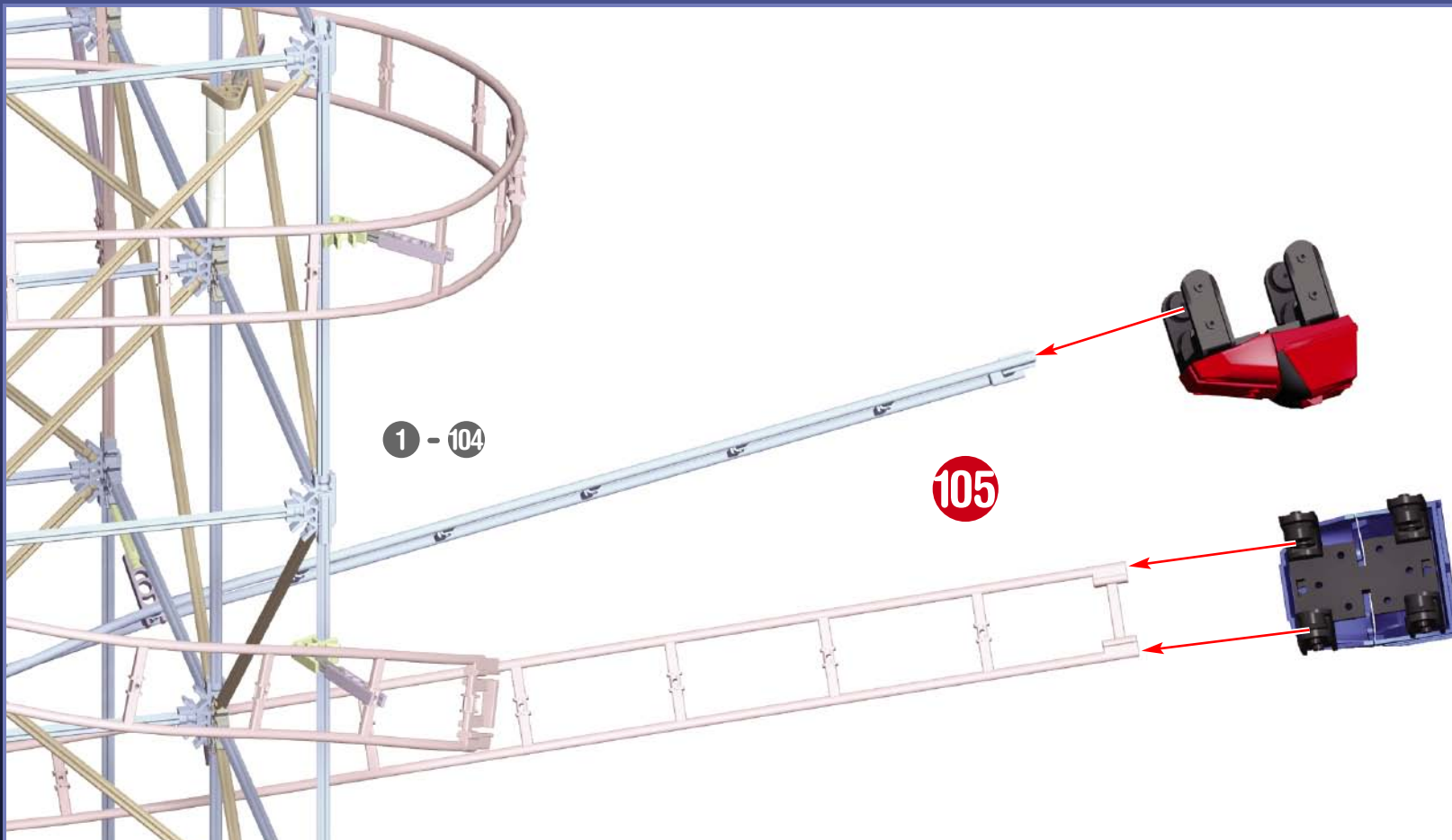

(EN) To attach the cars, undo a piece of track and then thread the car wheels over the top side of the track. Then join the track pieces together. If the cars get stuck on the way down, make sure they are not hitting any K'NEX parts.

(ES) Para sujetar los coche, desarma una pieza de la pista y entonces ensarta las ruedas del coche sobre el lado superior de la pista. Luego, junta las piezas de la pista. Si los coches quedan atascados mientras van hacia abajo, asegúrate de que el coche no esté golpeando ninguna de las piezas K'NEX.

(FR) Pour fixer les voiture, défais un tronçon du circuit, puis fais passer les roues de la voiture par-dessus le côté supérieur du circuit. Assemble ensuite les tronçons du circuit. Si des voiture restent coincées au cours de la descente, vérifie que la voiture ne heurte pas des pièces K'NEX.

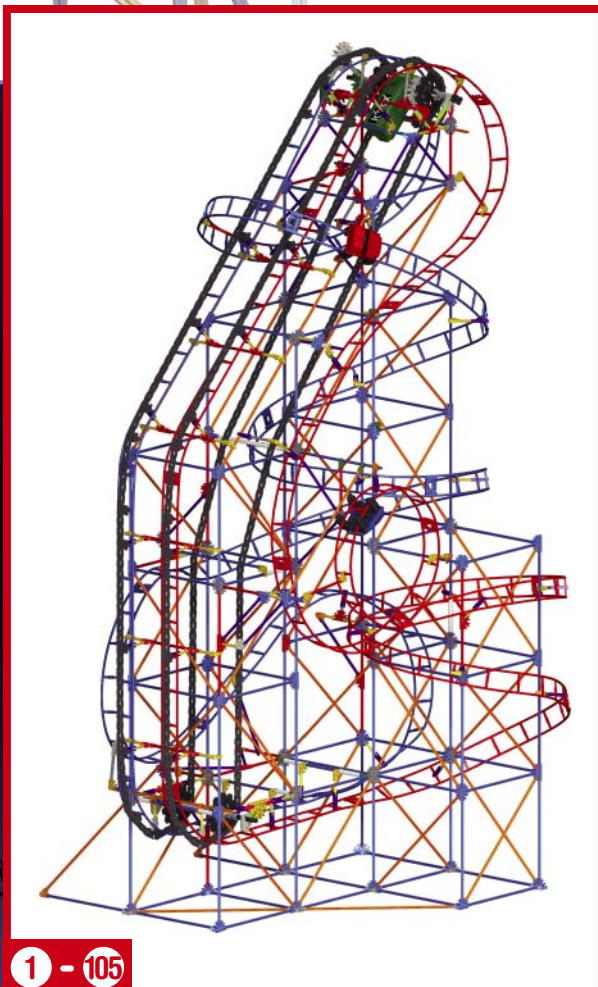

(EN) TIPS & TROUBLESHOOTING

If the motor is not working properly:

- Check to see if you have fresh batteries and that they are installed correctly.
- If it is still not working, call our Consumer Hotline at 1-800-KID-KNEX (USA and Canada only). See the back cover for other ways to contact K'NEX.

If a car gets stuck on the track:

- Is the model built correctly?
- Make sure the cars are not hitting any K'NEX parts.
- Are the track pieces connected properly?
- Are the cars attached to the track correctly?
- Adjust the track to eliminate any flat or little bumpy spots on the track.

(ES) CONSEJOS Y SOLUCIÓN DE PROBLEMAS

Si el Motor o el Módulo del Sonido no funcionan:

- Comprueba si tienes pilas nuevas y si están instaladas correctamente.
- Si aún así no trabaja, llama a nuestra Línea de Servicio al Cliente al 1-800-KID-KNEX (EE.UU. y Canadá solamente). Mira en la cubierta de atrás para otras formas de comunicarte con K'NEX.

Si los coches quedan atascados mientras van hacia abajo:

- ¿El modelo está construido correctamente?
- Asegúrate de que el coche no esté golpeando ninguna de las piezas K'NEX.
- ¿Las piezas de la Pista están conectadas correctamente?
- ¿El coche está sujetado a la Pista correctamente?
- Ajusta la Pista para eliminar cualquier lugar plano que le encuentres.

(FR) CONSEILS & DÉPANNAGE

Si le moteur ou le module son ne marche pas :

- Vérifie que tu as des piles neuves et qu'elles sont installées correctement.
- Si ça ne marche toujours pas, appelle notre ligne d'assistance à la clientèle à 1-800-KID-KNEX (USA et Canada uniquement). Regarde au verso pour d'autres moyens de contacter K'NEX.

Si des voitures restent coincées au cours de la descente :

- Est-ce que le modèle est construit comme il faut ?
- Vérifie que la voiture ne heurte pas des pièces K'NEX.
- Est-ce que les pièces du circuit sont connectées comme il faut ?
- Est-ce que la voiture est fixée au circuit comme il faut ?
- Ajuste le circuit de façon à y éliminer des endroits plats.

DOUBLEDROP COASTER™

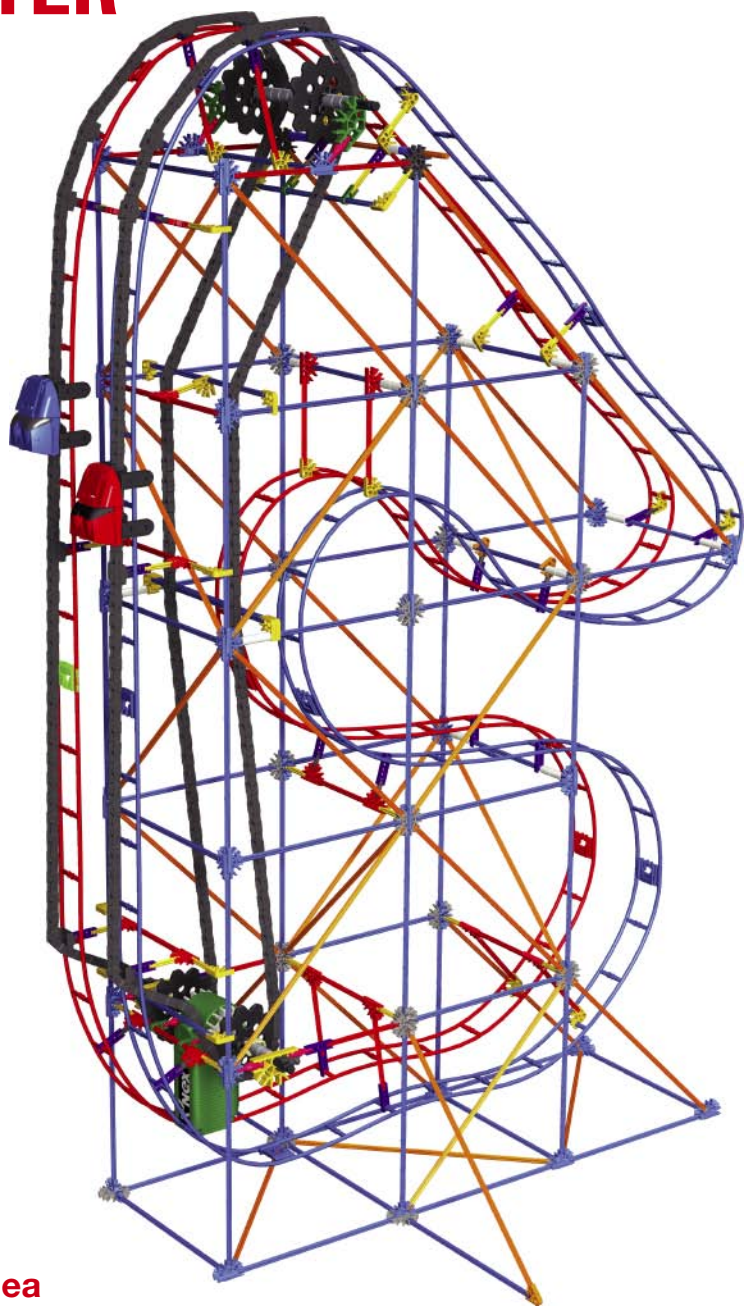

EN Building Idea

Bonus instructions at www.knex.com/thrill-rides

ES Idea para la construcción

Instrucciones de la prima en www.knex.com/thrill-rides

FR Idée de construction

Plans supplémentaires à www.knex.com/thrill-rides

DE Bauvorschlag

Zusätzliche Bauanleitungen bei www.knex.com/thrill-rides

IT Idea di costruzione

Bonus Istruzioni a www.knex.com/thrill-rides

PT Ideia de construção

Instruções do bônus em www.knex.com/thrill-rides

NL Idee voor bouwen

De instructies van de bonus bij www.knex.com/thrill-rides

ES Español

(Página 2)

INFORMACIÓN IMPORTANTE PARA LOS PADRES Y NIÑOS

Guarda estas instrucciones en un sitio conveniente.
Contienen información importante de seguridad.

Lee todas las advertencias e instrucciones antes de comenzar
a construir y operar este modelo.

⚠ ADVERTENCIA: PELIGRO DE ASFIXIA - Piezas pequeñas. No es para niños menores de 3 años.

PRECAUCIÓN: Mantén el cabello, los dedos, la cara y la ropa alejada de las piezas móviles.

PRECAUCIÓN: Si el cabello del niño entra en contacto con las partes en movimiento del juguete, puede quedar enredado.

- Compartan la experiencia K'NEX con su niño y hagan que la construcción con K'NEX sea una divertida aventura de toda la familia.
- Dedica tiempo a disfrutar el proceso de construcción. ¡No te apresures!
- Mientras construyes, trata de colocar tu modelo en la misma dirección que se muestra en las instrucciones.
- El producto y los colores pueden variar.

INFORMACIÓN ACERCA DE LAS PILAS

PRECAUCIÓN:

- Asegúrese de insertar las pilas correctamente y de siempre seguir las instrucciones del fabricante del juguete y de las pilas.
- No mezcle pilas viejas con nuevas, ni pilas alcalinas, estándar (carbón-cinc) o recargables (níquel-cadmio). Se debe usar solamente pilas del mismo tipo, o las que se recomienden como equivalentes.
- Siempre retire las pilas débiles o gastadas del producto; no forme cortocircuito en los puntos de intercambio.
- Inserte las pilas de acuerdo con los esquemas de polaridad (+/-).

Consejos importantes

- Se recomiendan las pilas alcalinas.
- No se recomiendan las pilas recargables.
- Retire las pilas recargables del juguete antes de cargarlas; éstas deben ser cargadas solamente bajo la supervisión de un adulto.
- No se debe recargar las pilas que no son recargables.
- Mantenga los componentes sin polvo; no sumerja ni use en agua.
- No deseches las pilas en el fuego ya que pueden tener fugas, explotar y causar lesiones personales.
- Retire todas las pilas si el juguete no se usará por mucho tiempo.
- No meta las vainas pequeñas en los orificios del motor ya que dañarían el motor y no se podrían sacar.
- Proteja el medio ambiente desechando su producto y el embalaje de una manera responsable. El símbolo del recipiente con ruedas indica que el producto y las pilas no deben tirarse en la basura doméstica, ya que contienen sustancias que pueden dañar el medio ambiente y la salud. Por favor acuda a los lugares de recolección designados o a instalaciones de reciclaje para desechar el artículo o las pilas.

Cómo insertar y quitar las pilas

Utilizar un pequeño destornillador principal Phillips para aflojar el tornillo y para quitar la cubierta de batería. Insertar 2 AA (o LR6) baterías frescas en el compartimiento de batería con la polaridad correcta (+/-).

Consejos básicos de construcción de K'NEX

Empieza a construir

Para comenzar tu modelo, busca el 1 y sigue los números. Cada pieza tiene su propia forma y color. Simplemente mira los dibujos, busca las piezas correspondientes en tu juego y después conéctalas. Mientras construyes, trata de colocar tu modelo en la misma dirección que se muestra en las instrucciones. Los colores desteñidos muestran que esta sección ya está construida. Conecta las nuevas secciones en los lugares señalados por las flechas. Las nuevas piezas que agregues estarán en colores vivos.

Espaciadores

Hay lugares en tu modelo donde tendrás que agregar Espaciadores azules y plateados. Cerciórate de usar el color correcto y cuéntalos con cuidado.

Cadena

Asegúrate de fijar todos los elementos de la cadena en la misma dirección.

Conectores

Hay conectores azules y plateados con ranuras largas especiales. Se enganchan deslizándose como ves en los dibujos. Conecta estas piezas empujándolas hasta que oigas "clic".

Lista de piezas

Antes de empezar con la construcción, asegúrate de comparar las piezas en tu conjunto con la lista de las piezas aquí. Si faltan algunas, llámanos o escríbenos siguiendo las instrucciones en la página trasera. Estamos aquí para ayudarte.

FR Français

(Page 2)

INFORMATIONS IMPORTANTES POUR LES PARENTS ET LES ENFANTS

Garde ces instructions à portée de la main. Elles comportent d'importantes informations de sécurité.

Lis tous les avertissements et les instructions avant de commencer le montage et l'exploitation du modèle.

⚠ AVERTISSEMENT : DANGER D'ÉTOUFFEMENT - Petites pièces. Ne convient pas aux enfants de moins de 3 ans.

ATTENTION : Garde les cheveux, les doigts, la figure et les vêtements à l'écart de toutes les pièces mobiles.

ATTENTION : Faire attention de ne pas renverser le modèle. Le modèle devrait être placé sur une surface plate et dure.

- Partage l'expérience K'NEX avec ton enfant et fais du montage K'NEX un agréable projet de famille.
- Prends ton temps lors du montage. Ne te presse pas.
- Essaie de situer ton modèle dans le même sens que les instructions durant le montage.
- Le produit et les couleurs peuvent varier.

INFORMATIONS PILE

ATTENTION :

- S'assurer d'installer les piles correctement et de suivre toujours les directives des fabricants du jouet et des piles.
- Ne pas mélanger des piles neuves avec des piles usées. Ne pas mélanger des piles alcalines avec des piles standard (Leclanché), ou des piles rechargeables (au nickel-cadmium). Il convient d'utiliser uniquement des piles du type recommandé ou d'un type équivalent.

- Retirer toujours les piles faibles ou mortes du produit ; ne pas faire court-circuiter les terminaux.
- Installer les piles en respectant la polarité (+/-) comme l'indique le schéma.

Conseils importants

- Les piles alcalines sont recommandées.
- Il est déconseillé d'utiliser des piles rechargeables.
- Retirer les piles rechargeables du jouet avant de les recharger; elles doivent être chargées exclusivement en présence d'un adulte.
- Les piles qui ne sont pas rechargeables ne doivent pas être rechargées.
- Veiller à ce que les éléments restent à l'abri de la poussière ; ne pas les plonger dans l'eau ; ne pas utiliser dans l'eau.
- Ne pas jeter les piles dans le feu ; elles risqueraient de fuir ou d'exploser et d'entraîner des blessures.
- Retirer toutes les piles si le jouet restera inutilisé pendant longtemps.
- Ne mettez pas les petites tiges dans les trous du moteur, elles endommageraient le moteur et il n'est pas possible de les enlever.
- Aidez l'environnement en jetant votre produit et son emballage de manière responsable. Le symbole de la poubelle à roulettes indique qu'il ne faut pas jeter le produit et les piles avec les ordures ménagères car ils contiennent des substances pouvant être nocives à l'environnement et à la santé. Veuillez utiliser les points de collecte de déchets ou les centres de tri désignés lorsque vous jetez l'article ou les piles.

Comment mettre et retirer des piles

Utiliser un petit Phillips tournevis pour desserrer la vis et pour enlever la couverture de batterie. Insérer 2 AA (ou LR6) batteries fraîches dans le compartiment de batterie avec la polarité correcte (+/-).

(Page 3)

Notions de base K'NEX pour le montage

Démarre ta construction

Pour commencer ton modèle, trouve l'étape numéro 1 et suis les numéros. Chaque pièce a sa propre forme et sa propre couleur. Regarde les illustrations, trouve les pièces qui correspondent à ce que tu vois et assemble-les. Pour t'aider pendant que tu construis, oriente ton modèle dans le même sens que les instructions. Les flèches t'indiquent où les pièces s'assemblent, mais les points de raccordement n'ont pas tous des flèches. Les pièces de couleur délavée sont celles que tu as déjà assemblées.

Espaceurs

Il y a des endroits sur ton modèle où tu auras besoin de te servir d'espaceurs. Assure-toi d'utiliser la bonne couleur et le nombre d'espaceurs indiqué sur les instructions.

Chaîne

Assure-toi de fixer tous les maillons de la chaîne dans le même sens.

Connecteurs

Tu peux assembler ces connecteurs tout à fait uniques en les faisant glisser l'un avec l'autre. Pousse fort jusqu'à ce que tu entendes un « clic ». Lis les instructions attentivement et positionne-les horizontalement ou verticalement, en suivant exactement les illustrations.

Liste des pièces

Avant de commencer à construire, assure-toi de comparer les pièces dans ta boîte à la liste de pièces fournie ici. S'il manque quelque chose, téléphone-nous ou écris-nous en te servant des informations figurant au verso de la notice. Nous sommes là pour t'aider !

DE Deutsch

(Seite 2)

Was Eltern und Kinder unbedingt wissen sollten

Halte diese Anleitungen stets griffbereit. Sie enthalten alle wichtigen Sicherheitshinweise. Lies bitte alle Warnhinweise und Anleitungen, bevor du mit dem Bauen und Spielen beginnst.

WARNHINWEIS: ERSTICKUNGSGEFAHR - Vorsicht Kleinteile! Nicht für Kinder unter 3 Jahren geeignet.

VORSICHT: Haare, Finger, Gesicht und Kleidungsstücke nicht mit beweglichen Teilen in Berührung kommen lassen.

VORSICHT: Die Haare des Kindes können in Kontakt mit bewegenden Teilen des Spielzeugs kommen und sich verfangen.

- Helpfen Sie Ihrem Kind beim Bauen mit K’NEX und machen Sie aus diesem Bauprojekt ein Abenteuer mit Spaß und guter Laune für die gesamte Familie.
- Das Zusammenbauen macht Spaß, also nehmen Sie sich Zeit und hetzen Sie nicht!
- Versuche, dein Modell beim Zusammenbauen so zu orientieren, dass es in die gleiche Richtung weist, wie es in den Anleitungen beschrieben und gezeigt wird.
- Die Produkte und Farben unterscheiden sich eventuell von denen auf den Abbildungen.

Informationen zu den Batterien

VORSICHT:

- Achte darauf dass die Batterien korrekt eingelegt werden und folge den Anweisungen der Spielzeug- und Batterienfabrikanten.
- Mische keine alten und neuen Batterien oder alkaline Batterien, Standardbatterien (Kohle-Zink) oder wiederaufladbare Batterien (Nickel-Cadmium). Verwende nur Batterien des gleichen Typs oder des empfohlenen äquivalenten Typs.
- Leere oder verbrauchte Batterien aus dem Spielzeug entfernen; darauf achten, dass die Pole der Batterie nicht kurzgeschlossen werden.
- Beim Einlegen der Batterien auf die korrekte Polarität (+/-), wie dargestellt, achten.

Wichtige Tipps

- Alkaline Batterien werden empfohlen.
- Wiederaufladbare Batterien sind nicht empfohlen.
- Bei Verwendung von wiederaufladbaren Batterien müssen diese aus dem Spielzeug entfernt werden, bevor sie wieder aufgeladen werden; das Wiederaufladen darf nur unter Aufsicht eines Erwachsenen stattfinden.
- Nichtwiederaufladbare Batterien dürfen nicht wieder aufgeladen werden.
- Die Komponenten von Staub freihalten; nicht in Wasser tauchen.
- Zu entsorgende Batterien nicht ins Feuer werfen; sie können auslaufen oder explodieren und Körperverletzungen verursachen.
- Wenn das Spielzeug längere Zeit nicht verwendet werden soll, alle Batterien entfernen.
- In keine der Öffnungen des Motor kleine Stangen einsetzen; sie beschädigen den Motor un können nicht entfernt werden.
- Trage zum Umweltschutz bei und entsorge unser Produkt sowie die Verpackung in verantwortungsvoller Weise. Das Mülltonnen-Symbol bedeutet, dass das Produkt und die Batterien nicht dem Restmüll zugeführt werden dürfen, weil sie Stoffe enthalten, die sich schädigend auf die Umwelt und die Gesundheit auswirken können. Bitte recycle den Artikel bzw. die Batterien und werfe sie in die entsprechenden Recyclingcontainer.

Anweisungen zum Einlegen und Entfernen der Batterien

Einen kleinen Kreuzkopfschraubenzieher benutzen, um die Schraube zu lösen und die Batterieabdeckung zu entfernen. 2 frische AA (oder LR6) Batterien in den Batterieraum mit der korrekten Polarität einsetzen (+/-).

(Seite 3)

Grundlegende Bauanleitungen für K’NEX

Los geh'ts mit dem Bauen

Um mit dem Bauen deines Modells zu beginnen, suche die Nummer 1 und folge den laufenden Nummern. Jedes Teil hat seine eigene Form und Farbe. Schau dir einfach die Abbildungen an, such die Teile in deinem Bausatz, die so aussehen wie das, was du auf der Abbildung siehst und steck sie ineinander. Versuche, dein Modell beim Zusammenbauen so zu orientieren, dass es in die gleiche Richtung weist, wie es in den Anleitungen beschrieben und gezeigt wird. Blasse Farben weisen darauf hin, dass dieser Streckenabschnitt bereits zusammengebaut ist.

Abstandsstücke

An manchen Stellen in deinem Modell musst du Abstandsstücke einbauen. Achte darauf, die richtige Farbe und Anzahl von Abstandsstücken wie in der Anleitung gezeigt zu verwenden.

Kette

Achte darauf, alle Kettenglieder in der gleichen Richtung zu verbinden.

Verbindungsstücke

Blaue und silberfarbene verbindungsstücke haben besonders lange Schlitz. Wie du vauf der Abbildung sehen kannst, lassen sie sich ineinander schieben. Achte beim Aneinanderfügen dieser Teile darauf, dass du ein Klickgeräusch hörst. Erst dann sind die Teile fest miteinander verbunden.

eileliste

Bevor du mit dem Bauen anfängst, solltest du prüfen ob die Teile in deinem Bausatz mit denen auf dieser Teilleiste übereinstimmen. Falls etwas fehlt, rufe uns an oder schreibe uns (siehe Rückseite). Wir sind für dich da!

(Seite 21)

Tipps für die Schienen:

Hierzu müssen die Metallstifte der Schienenstücke aufeinander ausgerichtet sein.

Drücke sie so fest, dass sie einhaken.

Die einzelnen Schienenstücke müssen immer mit der Oberseite nach oben zeigen, wenn sie miteinander verbunden werden.

(Seite 51)

Die wagen werden eingehängt, indem ein schienenstück entfernt wird. Dann kannst du die räder des wagens an der oberseite der schienen einhängen. Die schienenstücke werden dann wieder miteinander verbunden. Falls die wagen bei der Abfahrt stecken bleiben, überprüfe, ob der wagen gegen einzelne bauteile stößt.

Tipps und Fehlerbehebungen

Falls der Motor oder das Soundmodul nicht funktionieren:

- Überprüfe, ob die Batterien voll sind und richtig eingelegt sind.
- Falls es immer noch nicht funktioniert, kannst du innerhalb der USA und Kanadas unsere Hotline anrufen (Tel. 1-800-KID-KNEX). Auf der Rückseite dieser Anleitung findest du – weitere Möglichkeiten, K’NEX, zu kontaktieren.

Falls die Wagen bei der Abfahrt stecken bleiben:

- Ist das Modell richtig zusammengebaut?
- Überprüfe, ob der Wagen gegen einzelne Bauteile stößt.
- Sind die Schienenstücke richtig miteinander verbunden?
- Sitzt der Wagen richtig auf den Schienen?
- Ändere den Schienenverlauf so, dass die Wagen immer genügend Schwung haben.

IT Italiano

(Pagina 2)

Informazioni importanti per bambini e genitori

Tenere queste istruzioni a portata di mano. Contengono importanti informazioni di sicurezza. Leggere tutte le avvertenze e le istruzioni prima di iniziare a costruire il modello e di farlo funzionare.

AVVERTENZA: PERICOLO DI SOFFOCAMENTO - Piccole parti. Non adatto a bambini di età inferiore ai 3 anni.

ATTENZIONE: Tenere i capelli, le dita, il viso e i vestiti lontano da tutte le parti in movimento.

ATTENZIONE: I capelli del bambino potrebbero impigliarsi se vengono a contatto con le parti del giocattolo in movimento.

- Condividi l'esperienza di K’NEX con tuo figlio e rendi la costruzione con K’NEX un divertimento per tutta la famiglia.
- Prendi il tempo necessario per divertirti durante il processo di costruzione. Non ti affrettare!
- Orienta il tuo modello nella stessa direzione indicata nelle istruzioni.
- Il prodotto e i colori possono variare.

Informazioni sulle batterie

ATTENZIONE:

- Accertarsi di inserire le batterie correttamente e seguire sempre le istruzioni del produttore delle batterie e del giocattolo.
- Non mettere insieme batterie nuove e vecchie o alcaline, standard (carbonio-zinco) e ricaricabili (nichel-cadmio). Usare sempre batterie raccomandate dello stesso tipo o di tipo equivalente.
- Rimuovere sempre batterie quasi scariche o completamente scariche dal prodotto; non causare corto circuito ai terminali di alimentazione.
- Inserire le batterie con la polarità corretta (+/-) come illustrato.

Consigli importanti

- Si raccomanda l'uso di batterie alcaline.
- Non si raccomanda l'uso di batterie ricaricabili.
- Rimuovere le batterie ricaricabili dal giocattolo prima della carica: devono essere caricate solo sotto la supervisione di un adulto.
- Le batterie non ricaricabili non devono essere ricaricate.
- Mantenere i componenti privi di polvere; non immergere o usare in acqua.
- Non gettare le batterie nel fuoco, poiché potrebbero perdere o esplodere e causare lesioni.
- Rimuovere tutte le batterie se il giocattolo non verrà usato per un lungo periodo di tempo.
- Non inserire aste più corte di 5,1 cm (2 pollici) nei fori del motore, in quanto danneggerebbero il motore e non possono essere rimosse.
- Aiuta l'ambiente eliminando il prodotto e la confezione in modo responsabile. Il simbolo concernente il secchio con le ruote indica che il prodotto e le batterie non possono essere eliminati con la spazzatura domestica in quanto contengono sostanze che possono danneggiare l'ambiente e la salute. Usare i punti di raccolta designati o gli impianti di riciclaggio quando si devono eliminare l'articolo e le batterie.

Come inserire e rimuovere le batterie

Utilizzare un piccolo cacciavite phillips per allentare la vite e per rimuovere la copertura di batteria. Inserire 2 AA (o LR6) batterie fresche nello scompartimento di batteria con la polarità corretta (+/-).

(Pagina 3)

Istruzioni di base per costruire con K’NEX

Comincia a costruire

Per iniziare il modello, cerca il numero 1 e segui i numeri. Ogni pezzo ha una sua forma e un suo colore. Guarda la figura, trova i pezzi corrispondenti nel set e mettili insieme. Cerca di tenere il modello nella stessa direzione della figura e in tal modo sarà più semplice attaccare i pezzi nei posti giusti. I colori spenti ti dicono che questa sezione è già stata costruita. Dovrai collegare la nuova sezione al punto indicato dalla punta della freccia.

Spaziatori

Ci sono punti nel tuo modello a cui dovrai aggiungere spaziatori blu e argento. Accertati si contarli attentamente.

Catena

Accertati di attaccare tutti i collegamenti della catena nella stessa direzione.

Connettori

È molto importante posizionare i connettori blu e argento in una specifica direzione. Presta molta

attenzione alle istruzioni e posiziona i connettori orizzontalmente o verticalmente proprio come illustrato. Spingi con forza fino ad udire un clic.

Elenco delle parti

Prima di cominciare a costruire, accertati di confrontare le parti che sono nel tuo set con l'elenco delle parti qui. Se ne manca una chiamaci o scrivici usando le informazioni che sono nella retrocopertina. Noi siamo qui per aiutarli!

(Pagina 21)

Punte delle rotaie:

Attacca le guide a catena sulla parte superiore della rotaia. Collega i connettori sulla base della rotaia esattamente come illustrato.

Premi i connettori saldamente fino a che si fissano con uno scatto.

Collega sempre la rotaia parte superiore a parte superiore in tutta la costruzione.

(Pagina 51)

Per collegare le carrozza, stacca un pezzo di rotaia e quindi infila le ruote della carrozza sulla parte superiore della rotaia. Quindi unisci i pezzi della rotaia. Se le carrozze si arrestano durante la discesa, Controlla che la carrozza non abbia colpito qualche altra parte K’NEX.

Suggerimenti e risoluzione dei problemi

Se il motore o il modulo del suono non funzionano:

- Controlla che le batterie siano nuove e che siano installate correttamente.
- Se ancora non dovesse funzionare, chiama il numero di assistenza ai clienti 1-800-KID-KNEX (USA e Canada soltanto). Vedi il retro della scatola per trovare altri modi di contattare K’NEX.

Se le carrozze si arrestano durante la discesa:

- Il modello è costruito correttamente?
- Controlla che la carrozza non abbia colpito qualche altra parte K’NEX.
- I pezzi della rotaia sono collegati correttamente?
- La carrozza è collegata alla rotaia correttamente?
- Regola la rotaia per eliminare qualsiasi parte piatta sulla stessa.

PT Português

(Página 2)

Coisas importantes para os Pais e os Miúdos

Mantenha estas instruções num local de fácil acesso, pois contém informações importantes de segurança.

Lê as instruções e advertências antes de começares a construir e a operar o modelo.

AVISO: PERÍGO DE SUFOCAÇÃO - Peças pequenas. Não se destina a crianças com menos de 3 anos de idade.

CUIDADO: Mantém o cabelo, os dedos, a cara e a roupa afastados de todas as peças móveis.

CUIDADO: O cabelo da criança pode ficar emaranhado se entrar em contacto com as peças móveis do brinquedo.

• Compartilhe da experiência K’NEX com os miúdos e faça com que o processo de construção com K’NEX se torne numa aventura entre família.

• Não te precipites para assim poderes desfrutar do processo de construção. Não o faças à pressal

• Tenta fazer com que o teu modelo esteja virado exactamente na mesma direcção indicada nas instruções.

• Tanto o produto como as respectivas cores podem variar.

Informações sobre as pilhas

CUIDADO:

- Certifique-se de que introduz as pilhas correctamente e siga sempre as instruções do fabricante da bateria e do brinquedo.
- Não combine pilhas usadas com pilhas novas, pilhas alcalinas, padrão (carbono-zinco) ou pilhas recarregáveis (níquel-cádmio). Deverão ser usadas apenas pilhas do mesmo tipo ou equivalentes ao tipo recomendado.
- Retire sempre as pilhas fracas ou gastas do produto; não provoque um curto-circuito nos terminais de alimentação.
- Introduza as pilhas com a polaridade correcta (+/-), conforme se mostra.

Conselhos importantes

- Recomenda se o uso de pilhas alcalinas.
- Não se recomenda o uso de pilhas recarregáveis.
- Retire as pilhas recarregáveis do brinquedo antes de as carregar; estas pilhas devem ser recarregadas apenas sob vigilância de adultos.
- As pilhas não recarregáveis não devem ser carregadas.
- Mantenha os componentes livres de poeiras; não mergulhe em água nem use água.
- Não elimine as pilhas queimando-as; estas podem apresentar fugas ou explodir causando lesões.
- Retire todas as pilhas do brinquedo se não tencionar usá-lo durante um longo período de tempo.
- Não coloque varetas de tamanho inferior a 5,1 cm (2 pol.) em nenhuma abertura do motor; as varetas causarão danos no motor e não podem ser removidas.
- Ajude o ambiente eliminando o seu produto e a embalagem vazia responsabilmente. A imagem do contentor do lixo com rodinhas indica que o produto e as pilhas não devem ser eliminados juntamente com os resíduos domésticos pois contém substâncias que podem provocar efeitos negativos no ambiente e na saúde. Por favor use os pontos de recolha designados ou as instalações de reciclagem quando necessitar de eliminar o produto ou as pilhas.

Como inserir e remover as pilhas

Usar uma chave de fenda principal pequena de Phillips para afrouxar o parafuso e para remover a tampa de bateria. Introduzir 2 AA (ou LR6) baterias frescas no compartimento de bateria com a polaridade correta (+/-).

KNEX.COM

LOOPIN' LIGHTNING COASTER™

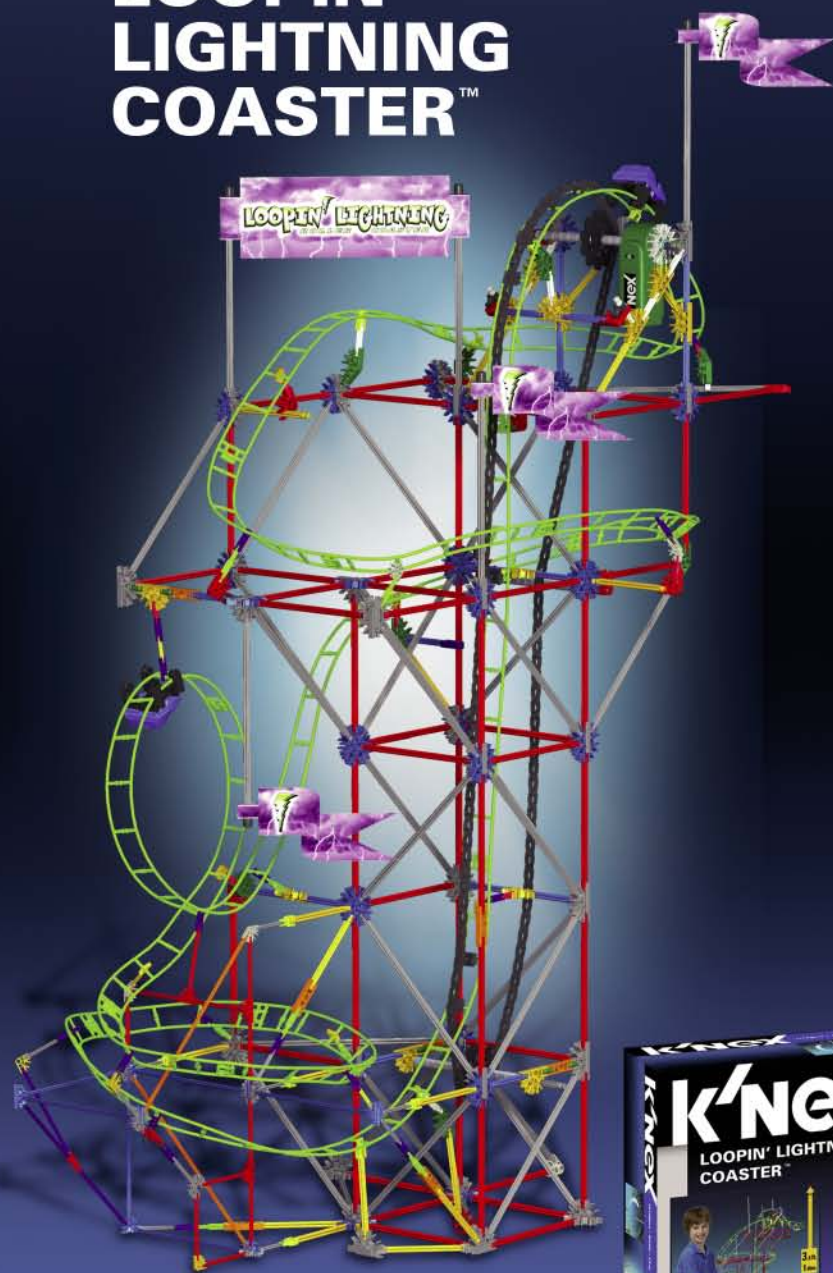

Sold separately. Some products may not be available in all markets.

Se venden por separado. Algunos productos no pueden estar disponibles en todos los mercados.

Vendus séparément. Certains produits ne sont pas disponibles pour tous les marchés.

Separat verkauft. Einige Produkte können möglicherweise nicht in allen Märkten vorhanden sein.

Venduto esclusivamente. Alcuni prodotti non possono essere disponibili in tutti i mercati.

Vendido separada. Alguns produtos não podem estar disponíveis em todos os mercados.

Afzonderlijk verkocht. Sommige producten kunnen niet in alle markten beschikbaar zijn.

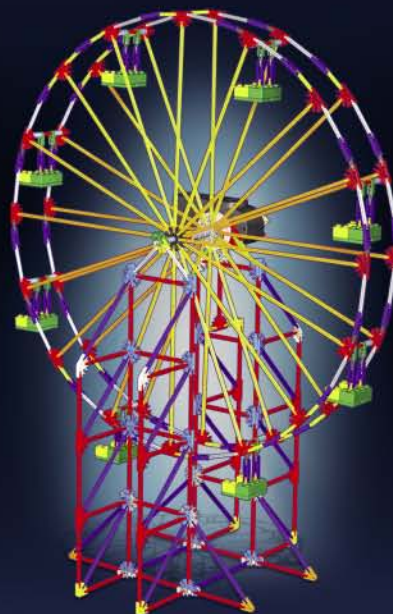

COLLECT & BUILD™



 Find us on Facebook

K'NEX Customer Service; Tel 1-800-KID-KNEX (USA/CAN only); email@knex.com; www.knex.com
For Customer Service outside USA/CAN contact your local distributor at: <http://www.knex.com/distributors>
(FR) Le Service clients hors d'USA/CAN, s'il vous plaît contacter le distributeur local. L'information à <http://www.knex.com/distributors>
(AZ) (NZ) (UK) (DE) (NL) (BE) (CH) (CL) (PE) <http://www.knex.com/distributors>
(UK) TOMY Careline, PO Box 20, Totton, Hants, SO40 3YF; Tel 023 8066 2600
(FR) ALLO TOMY SAV, Parc d'affaires International, 74166 ARCHAMPS; Tél 0 820 013 013
(UK) (FR) (DE) (NL) <http://www.tomy.eu>

Product & colors may vary. Standard K'NEX parts made in the USA. K'NEX and Imagine, Build, Play are registered trademarks of K'NEX Limited Partnership Group.

(ES) El producto y los colores pueden variar. Piezas estándar de K'NEX hechas en EE.UU. K'NEX y Imagine, Build, Play son marcas registradas de K'NEX Limited Partnership Group.

(FR) Produits et couleurs peuvent varier. Pièces K'NEX courantes fabriqués aux États-Unis. K'NEX et Imagine, Build, Play sont des marques déposées de K'NEX Limited Partnership Group.



CE

Tomy S040 3SA, England

©2011 K'NEX Limited Partnership Group
P.O. Box 700
Hatfield, PA
19440-0700

150542-V1-03/11