

# K'nex

## DINOSAUR DROP Roller Coaster Building Set

CHUTE DE  
DINOSAURE  
Montagnes Russes  
Jeu de construction

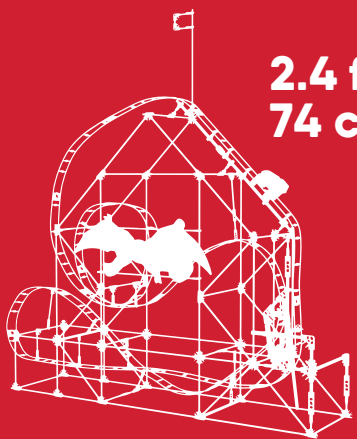

2.4 ft  
74 cm

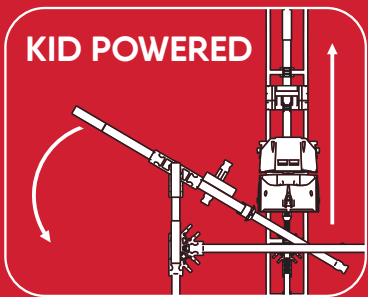

### ⚠️ WARNING:

CHOKING HAZARD – Small parts.  
Not for children under 3 years.

### ⚠️ ATTENTION :

RISQUE D'ÉTOUFFEMENT – Pièces de petite taille.  
Ne convient pas aux enfants de moins de 3 ans.

Ages

7-12

28041

# THRILL RIDES



K'nex  
RIDE IT!

## BUILD & RIDE APP

(EN) English

## Keep this important information for future reference

 **WARNING:** CHOKING HAZARD – Small parts. Not for children under 3 years.

**CAUTION:** Keep hands, face, hair and clothing away from all moving parts.

**CAUTION:** Be careful not to tip the model over. Model should be placed on a flat and hard surface.

Do not obstruct track with objects or any part of your body.

(FR) Français

## Gardez précieusement cette notice pour vous y référer ultérieurement

 **ATTENTION :** RISQUE D'ÉTOUFFEMENT – Pièces de petite taille. Ne convient pas aux enfants de moins de 3 ans.

**ATTENTION :** Garde les cheveux, les doigts, la figure et les vêtements à l'écart de toutes les pièces mobiles.

**ATTENTION :** Faire attention de ne pas renverser le modèle. Le modèle devrait être placé sur une surface plate et dure.

Ne pas bloquer les rails avec des objets ou la corps.

## Start Building

Each piece has its own shape and color. Just look at the pictures, find the pieces in your set that match and then connect them together. Try to face your model in the same direction as the instructions while you build. The arrows show you where the parts connect, but not all connections points have arrows. Faded colors show you this section is already built.

## Démarre ta Construction

Chaque pièce a sa propre forme et sa propre couleur. Regarde les illustrations, trouve les pièces qui y correspondent et les assemble-les. Pour te faciliter la tâche, oriente le modèle dans le même sens que les instructions. Les flèches indiquent où les pièces s'assemblent, mais les points de raccordement n'ont pas tous des flèches. Les pièces ayant une couleur estompée sont celles déjà assemblées.

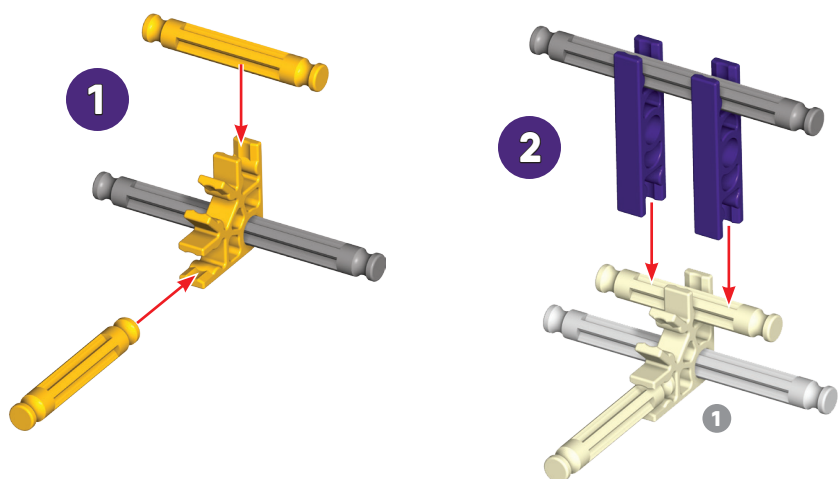

## Connectors

You can slide these special connectors together. Push tightly until you hear a "click". Pay close attention to the instructions and position them horizontally or vertically exactly as they are shown.

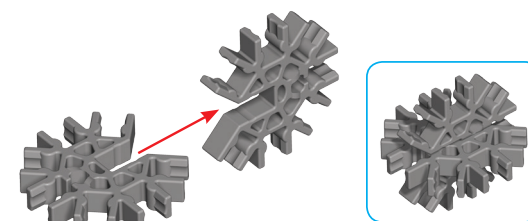

## Connecteurs

Tu peux assembler ces connecteurs spéciaux en les faisant glisser l'un dans l'autre. Pousse fort jusqu'à entendre un « clic ». Lis attentivement les instructions et positionne-les horizontalement ou verticalement, en suivant exactement les illustrations.

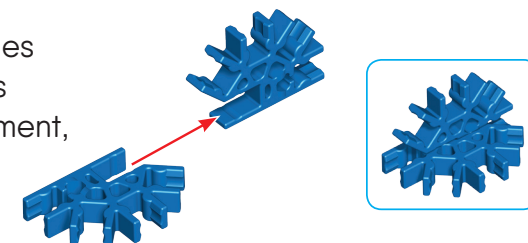
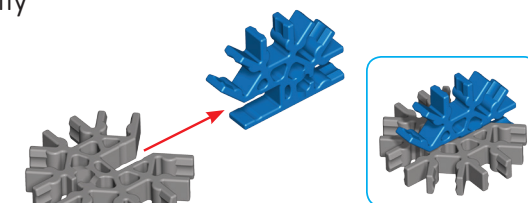

## Spacers

There are places in your model where you need to add spacers. Be sure to use the correct number of spacers shown in the instructions.

## Séparateurs

Il y a des endroits sur le modèle où des séparateurs sont nécessaires. Assure-toi d'utiliser la bonne nombre de séparateurs, comme indiqués sur les instructions.

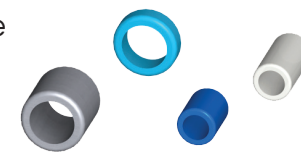

## Parts List

Before you start building, be sure to compare the parts in your set with the parts list here. If anything is missing, call or write to us using the information on the back cover. We are here to help you!

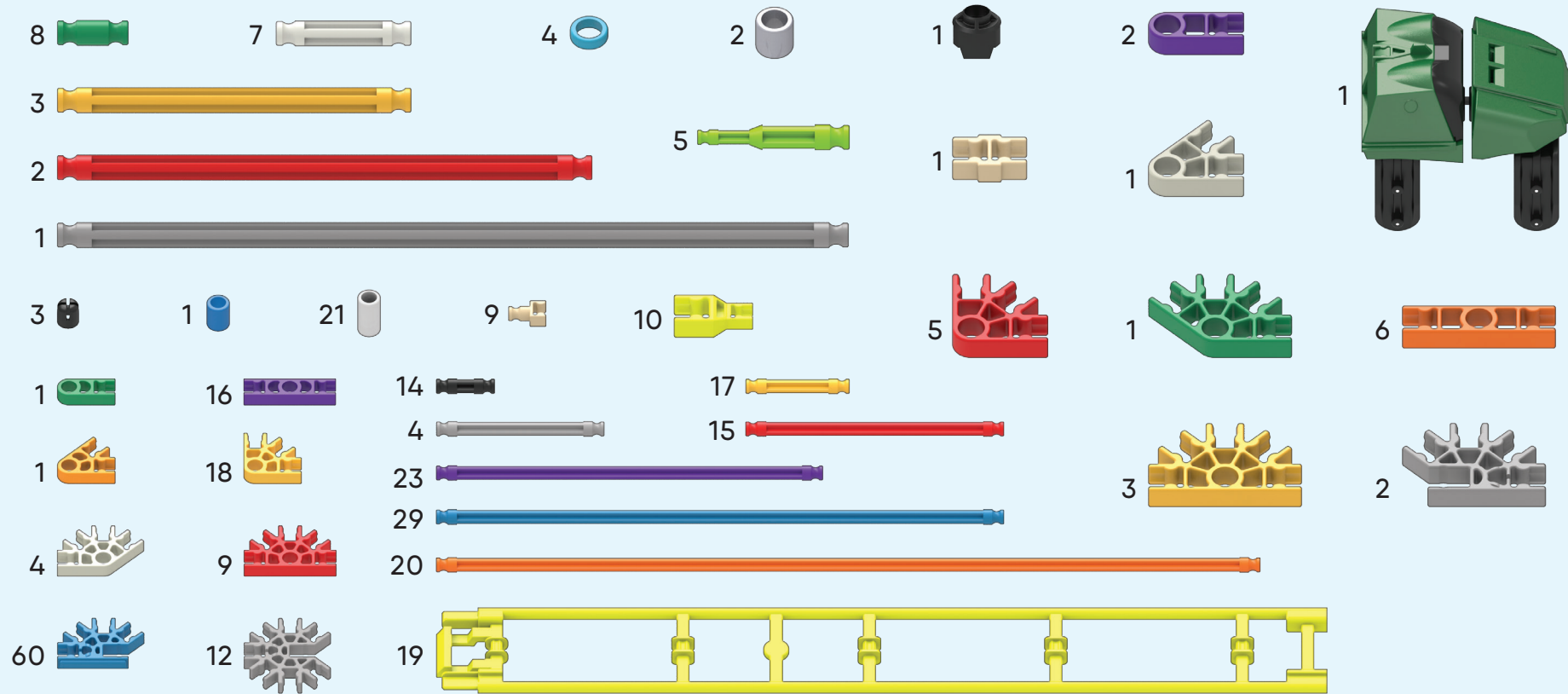

## Liste des Pièces

Avant de commencer à construire, assure-toi de comparer les pièces dans ta boîte à la liste de pièces fournie ici. S'il manque quelque chose, téléphone-nous ou écris-nous en te servant des informations figurant au verso de la notice. Nous sommes là pour t'aider !



Search "K'NEX RIDE IT!™" in the app store.

Compatible with most cardboard VR viewers\*.

\*Viewer not included or required.

§ Phone not included.

Recherchez "K'NEX RIDE IT!™" dans l'app store.

Compatible avec la plupart des visionneuses VR en carton\*.

\*Visionneuse non incluse ou requise.

§ Appareil non inclus.



**k'nex**

# DINOSAUR DROP CHUTE DE DINOSAURE



**TIP:** While you're building make sure you face your model in the same direction as the pictures show in the instructions.

**CONSEIL :** Essaye de situer ton modèle dans le même sens que les instructions durant le montage.

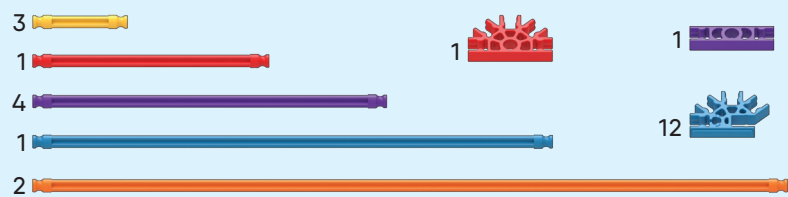

1

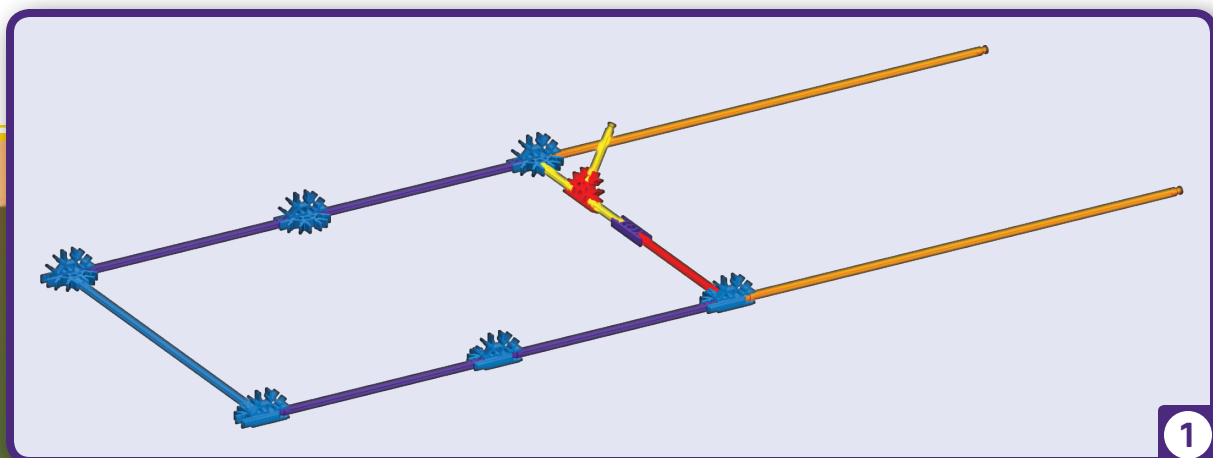
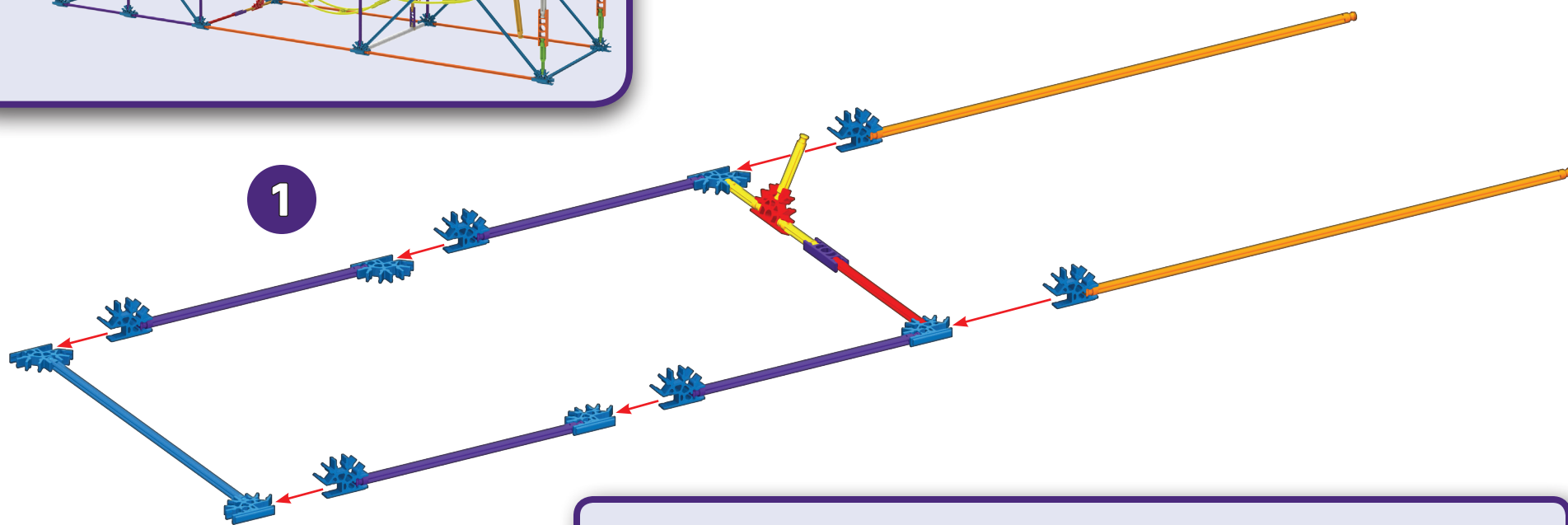

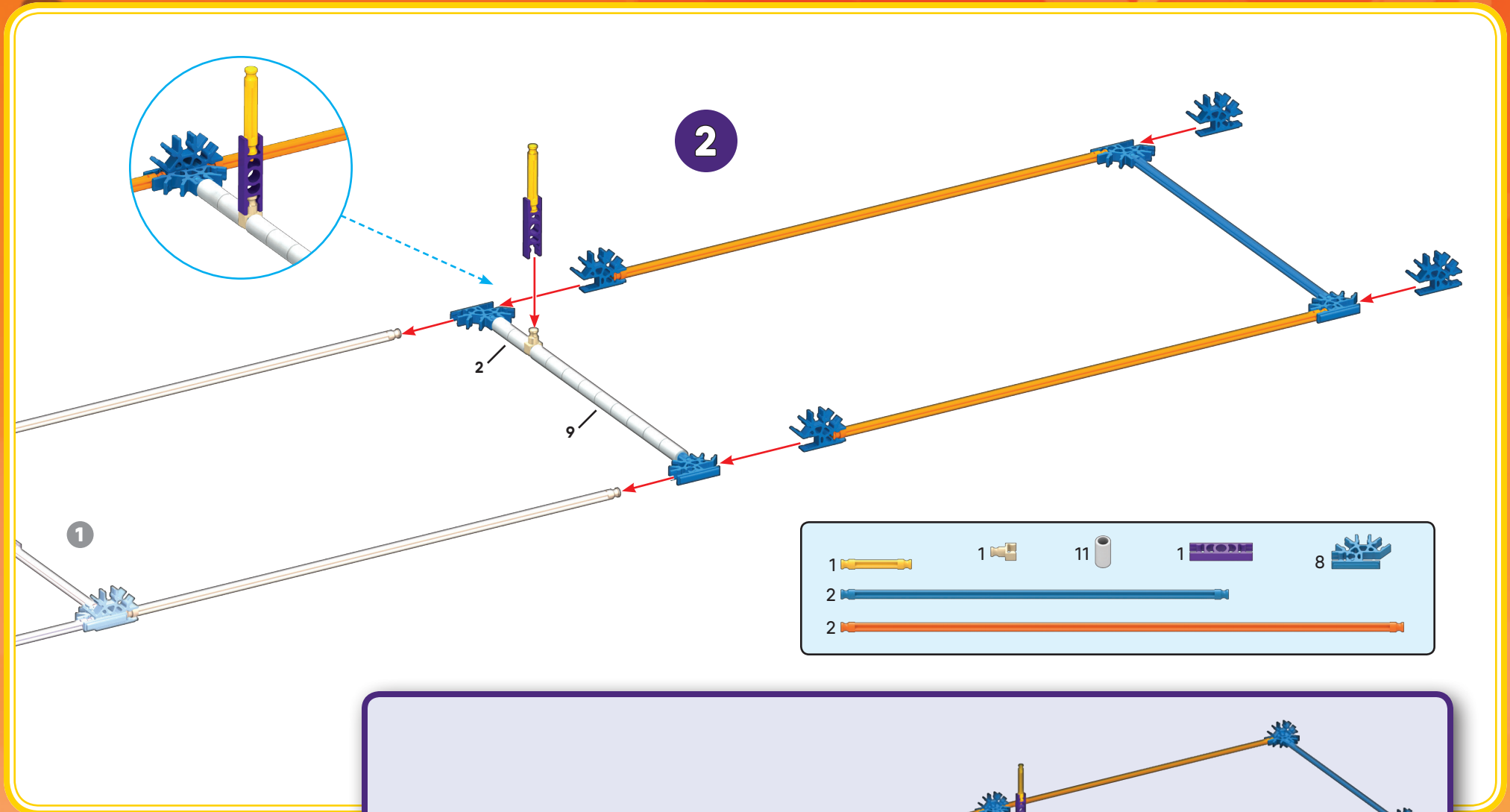



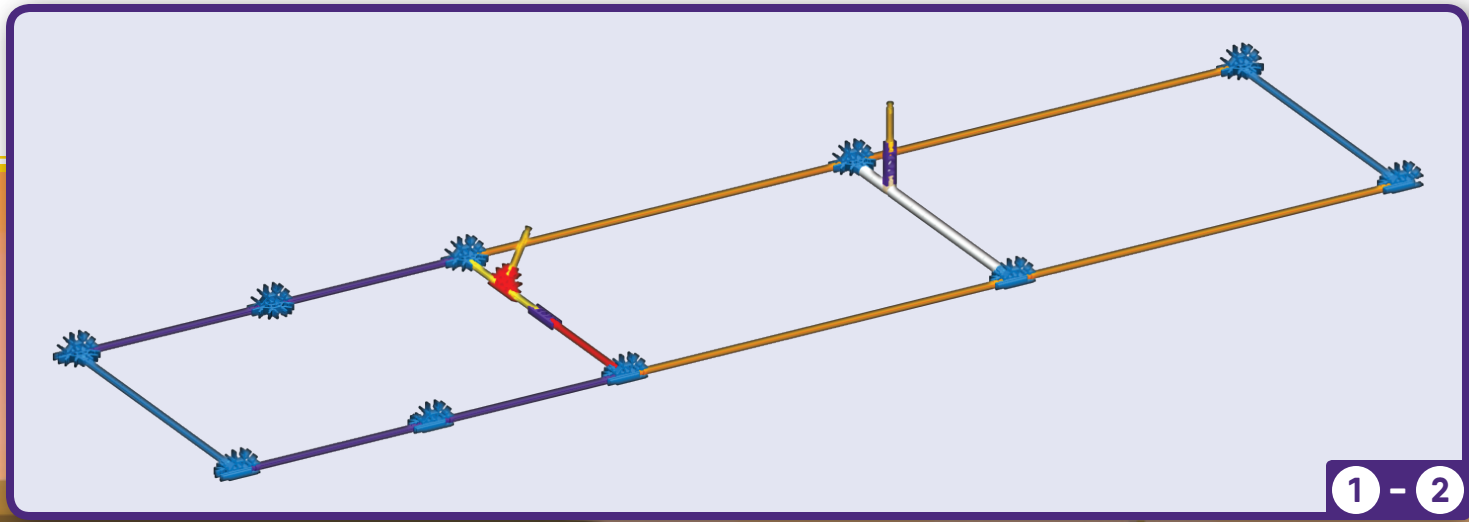

- |   |  |   |  |    |  |   |  |   |  |
|---|--|---|--|----|--|---|--|---|--|
| 1 |  | 1 |  | 11 |  | 1 |  | 8 |  |
| 2 |  |   |  |    |  |   |  |   |  |
| 2 |  |   |  |    |  |   |  |   |  |

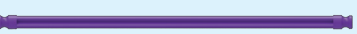

1 - 2

14  2  8 

2 

2 

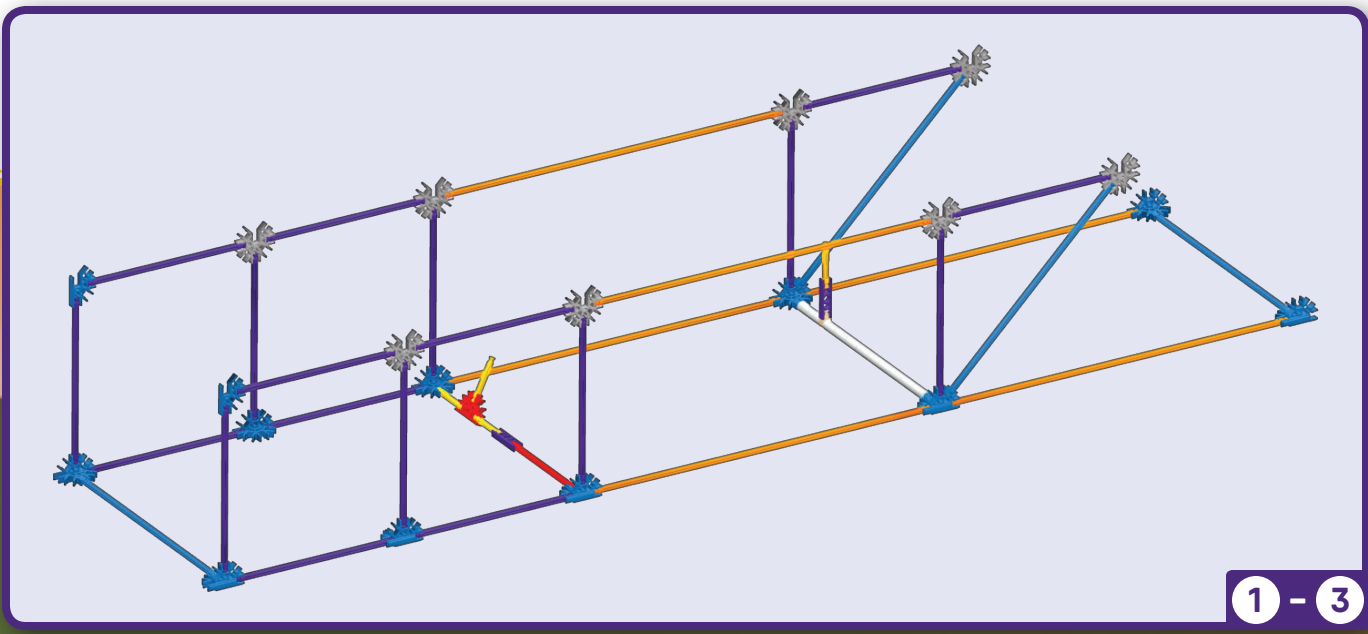
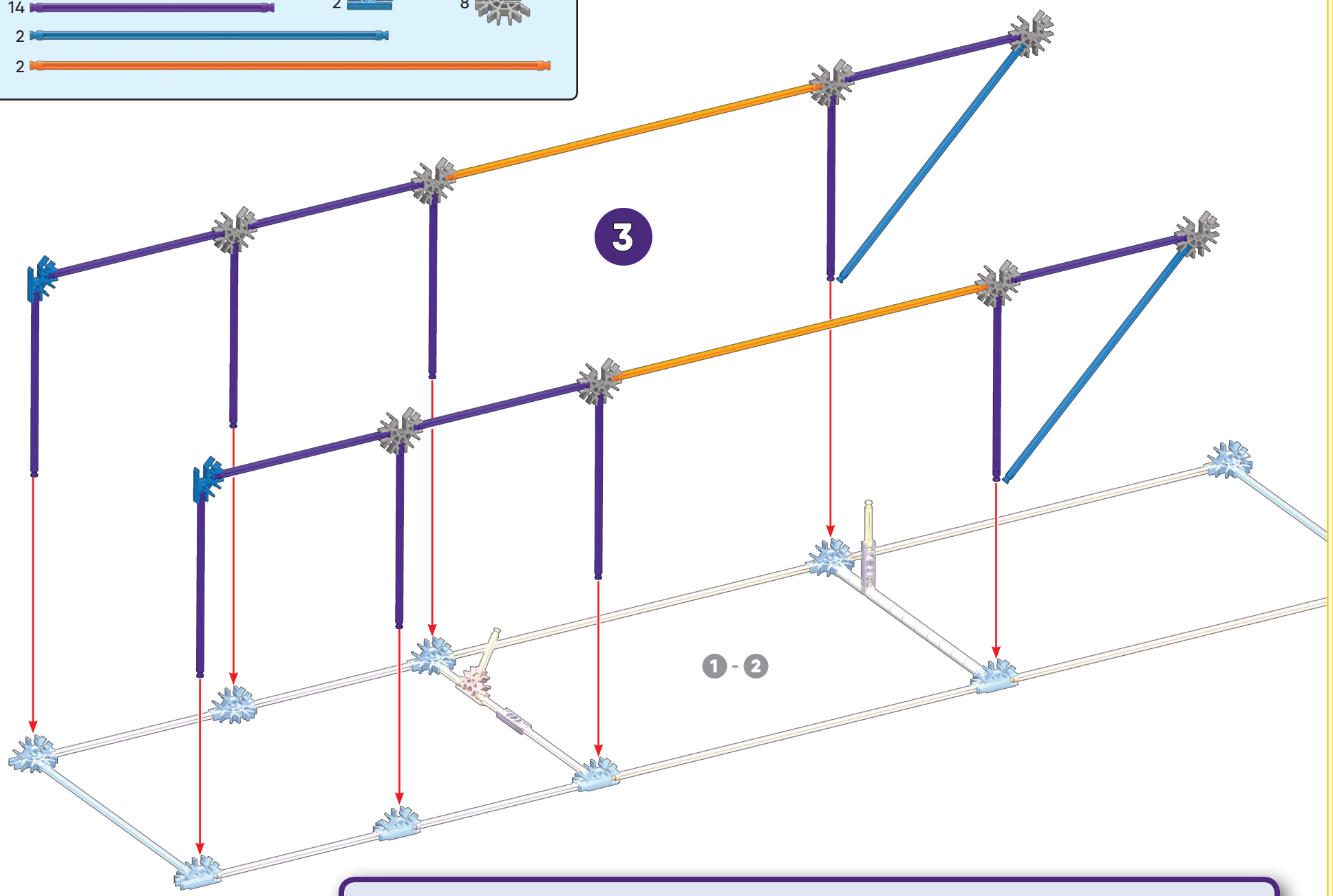

1	1	10	1
3		3	
2			
1	2		
1	2	6	

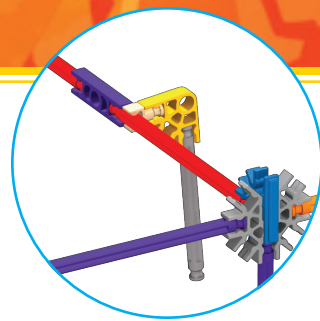
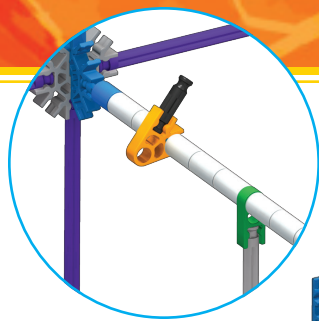
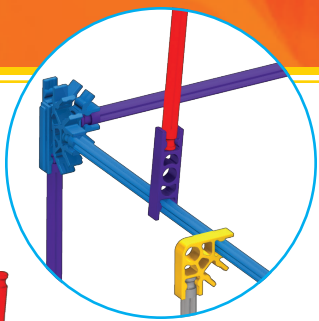

4

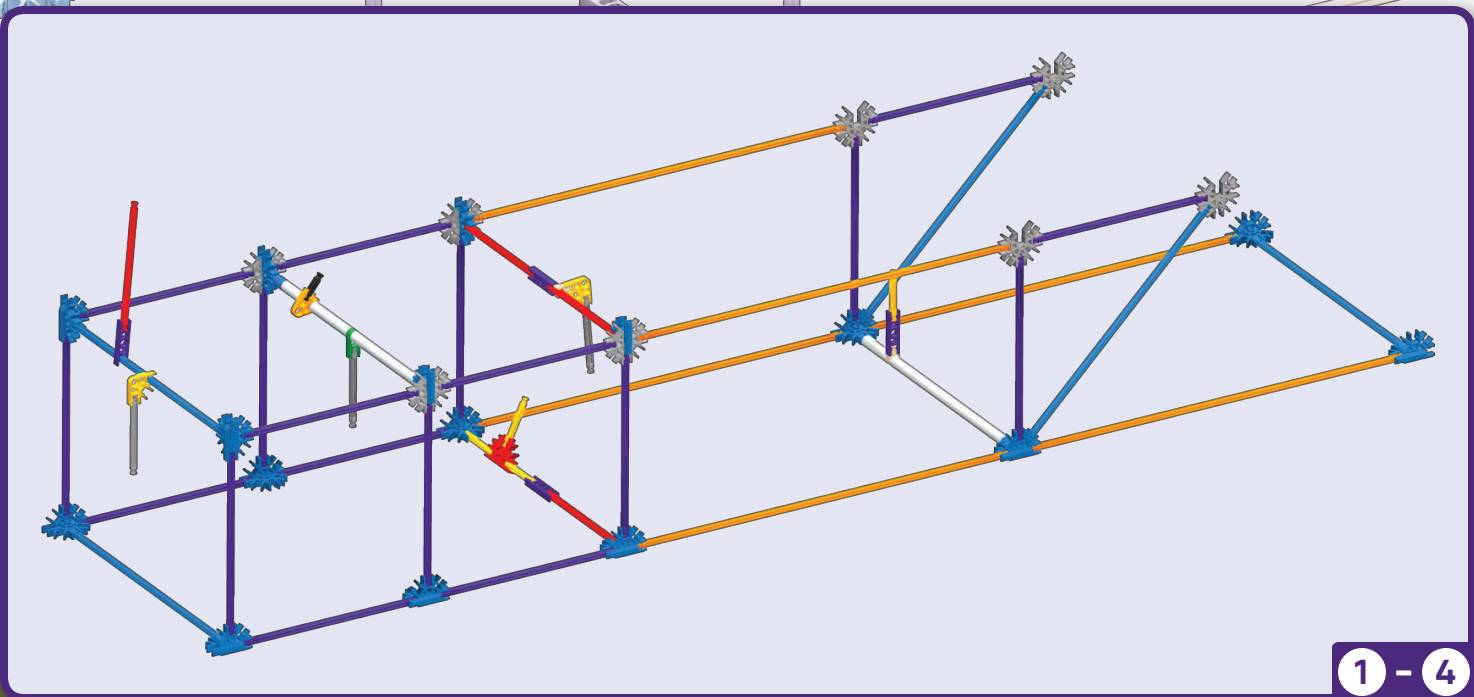
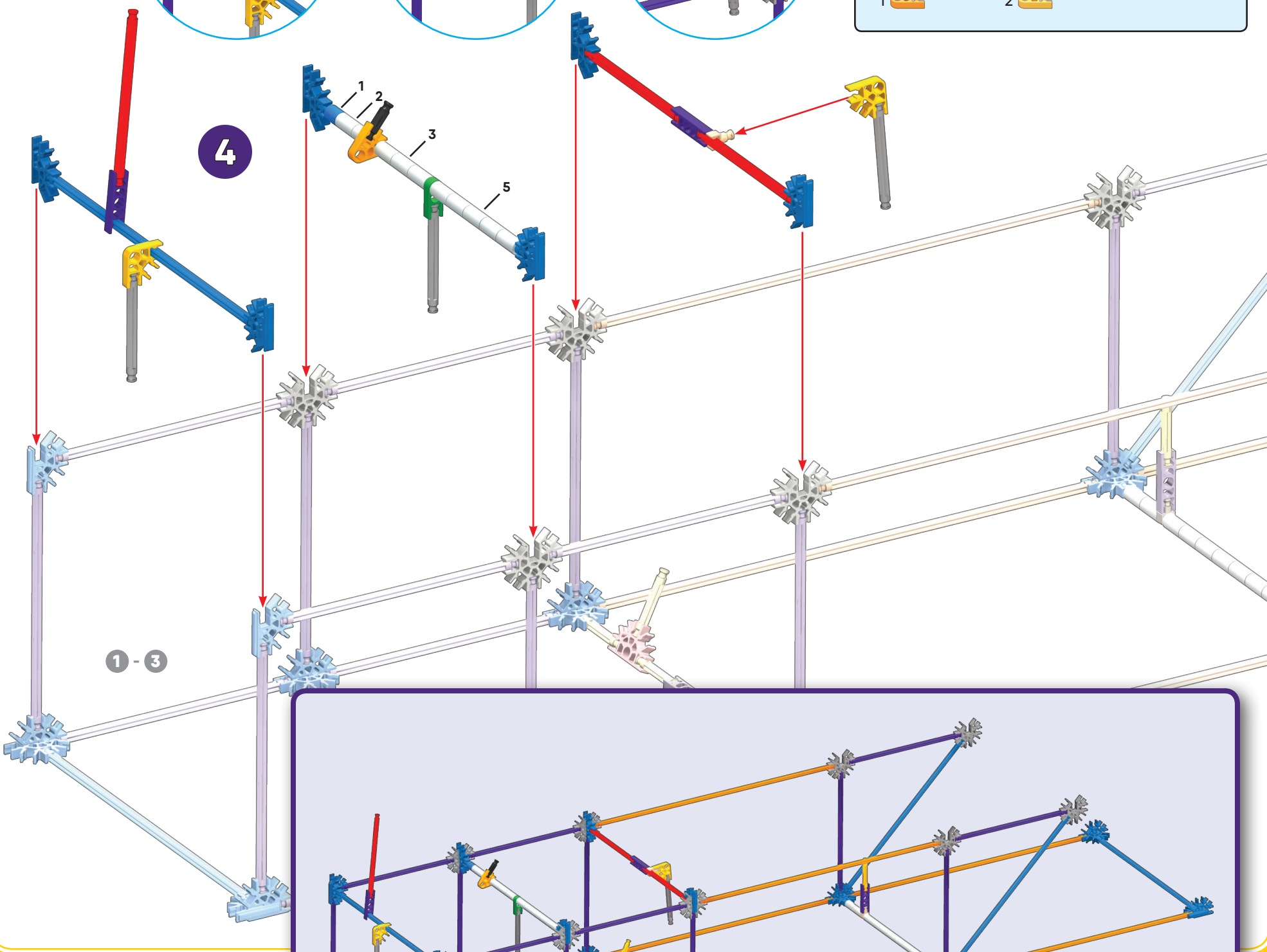

1 - 4

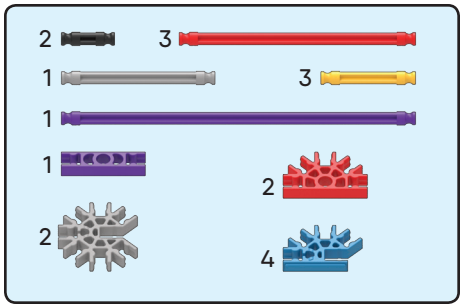

5

1 - 4

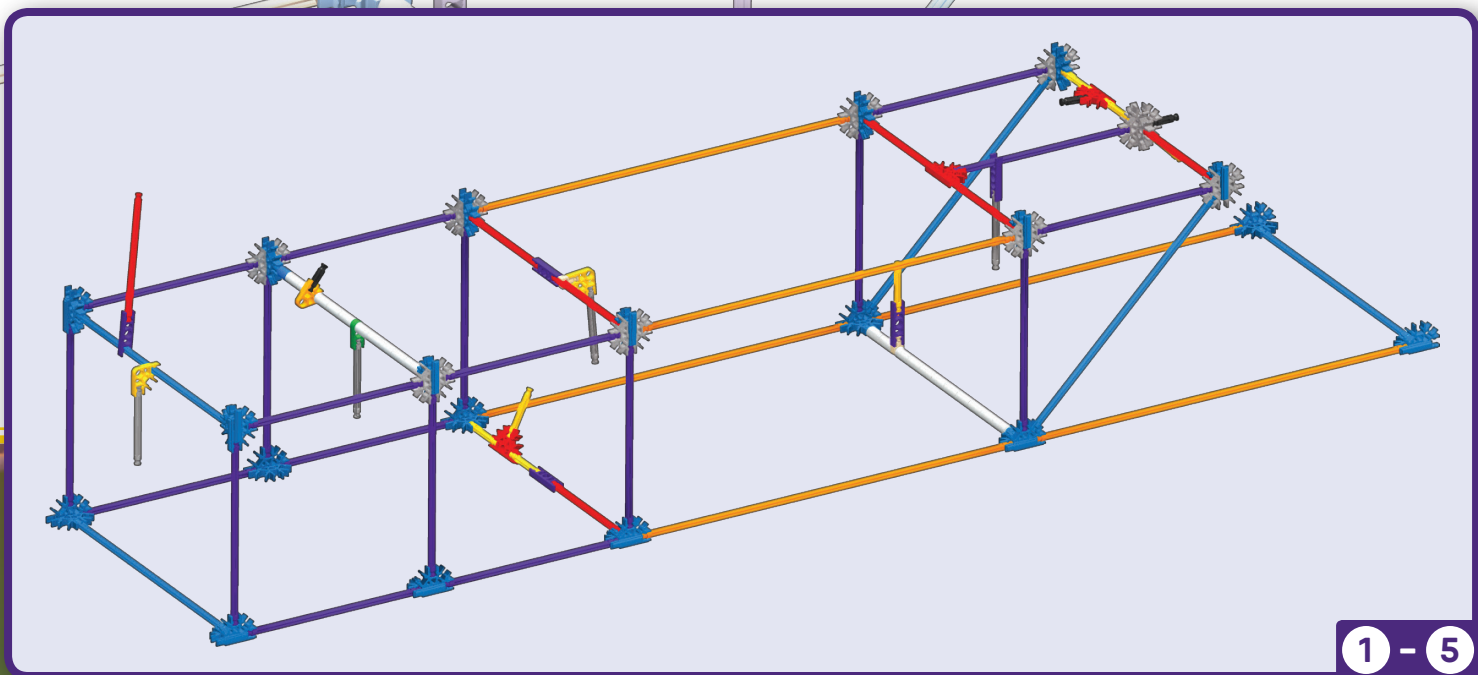
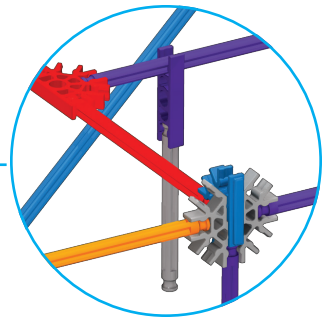

1 - 5

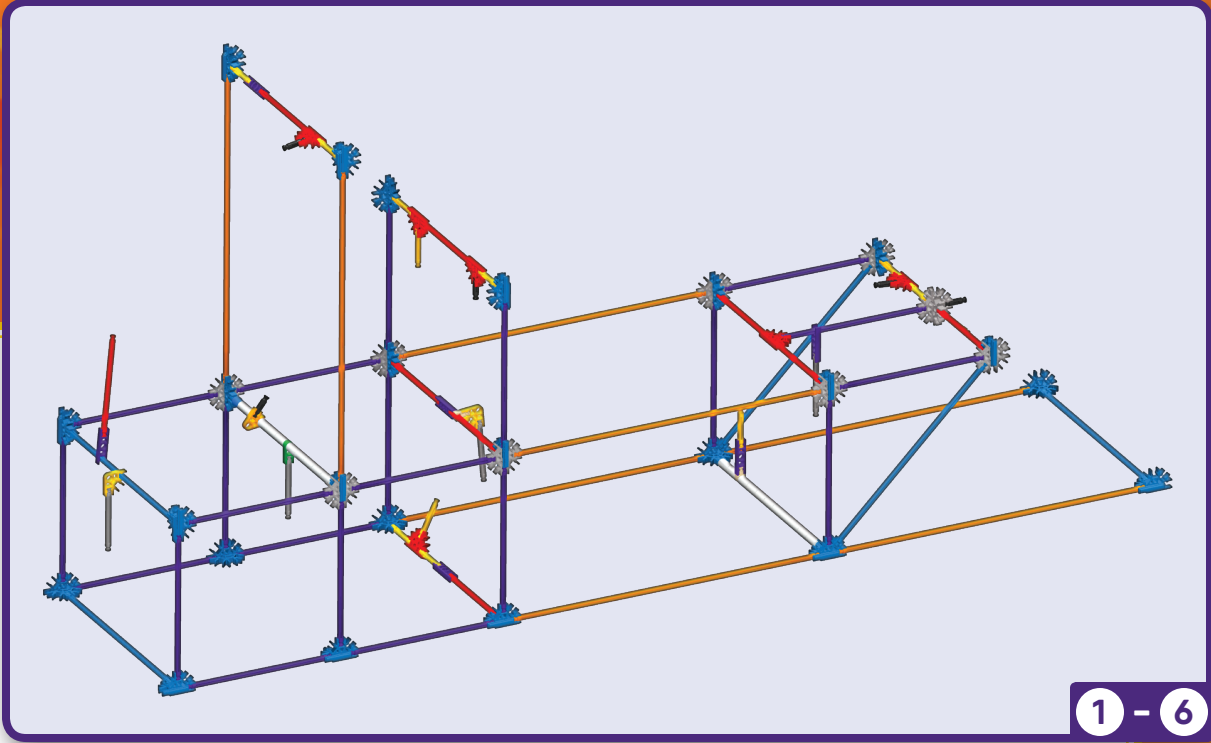

6

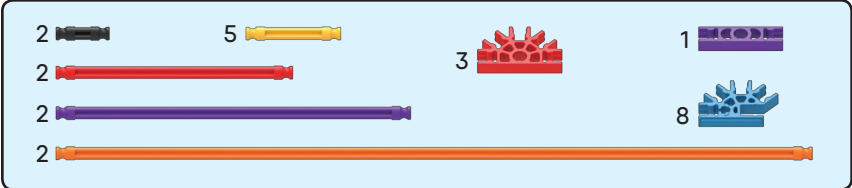

1 - 5

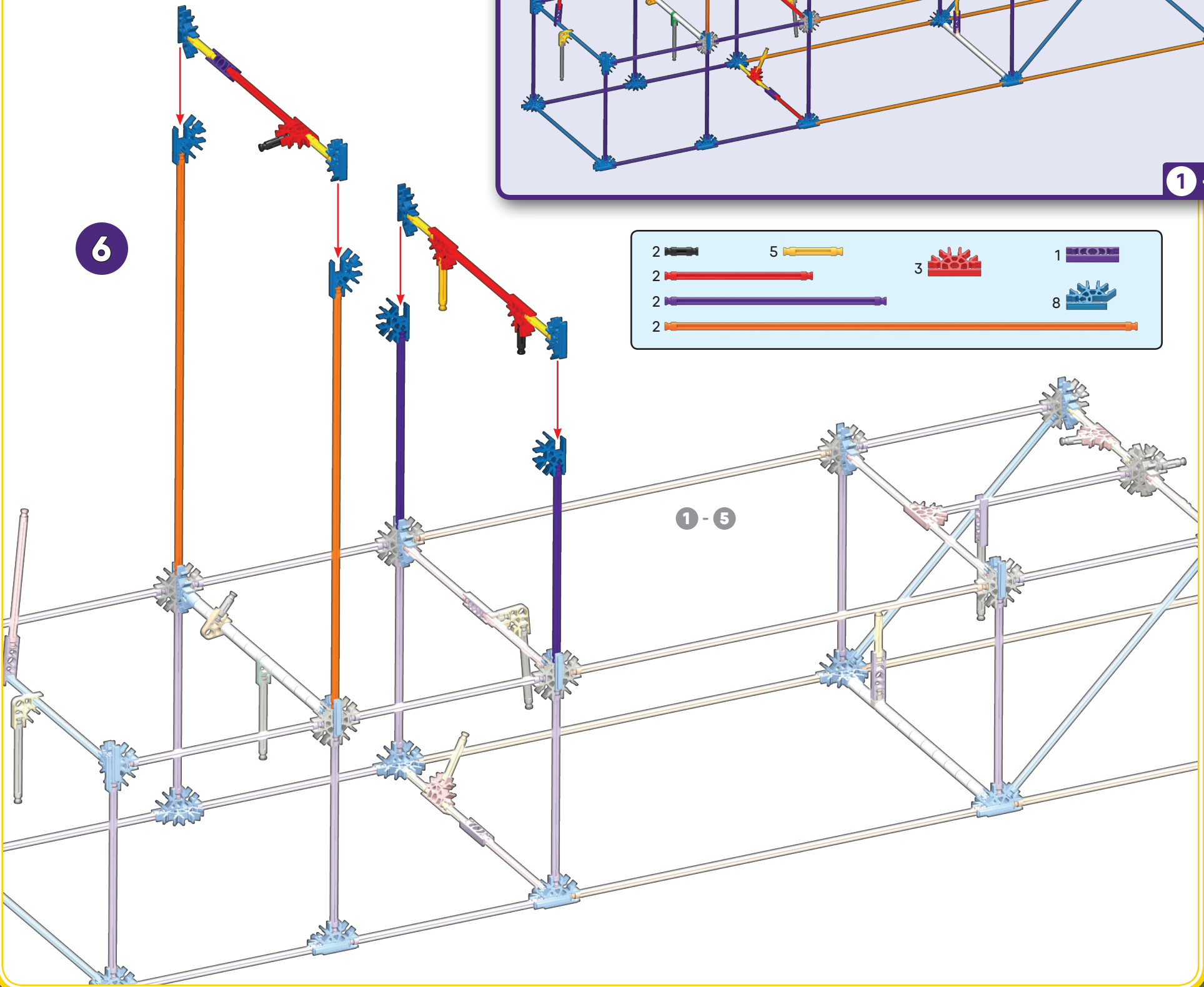

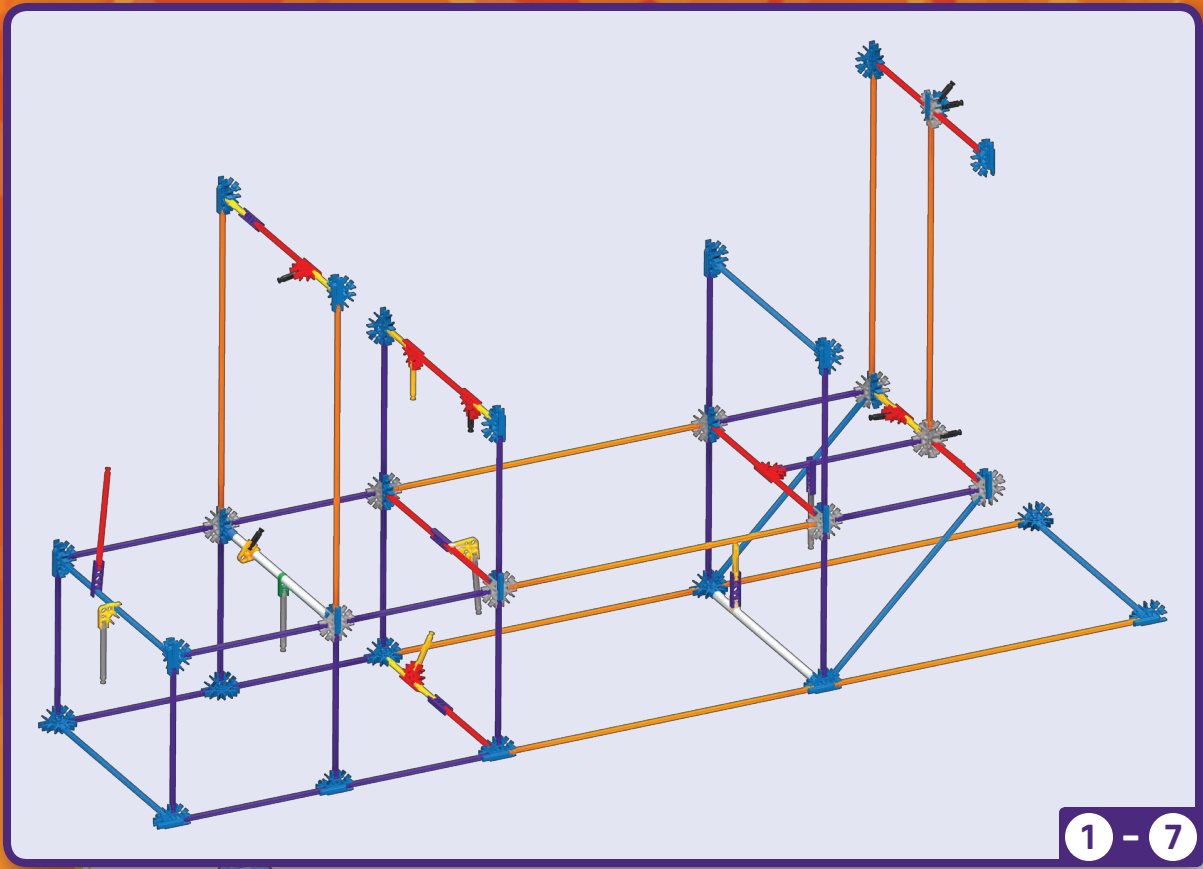

1 - 7

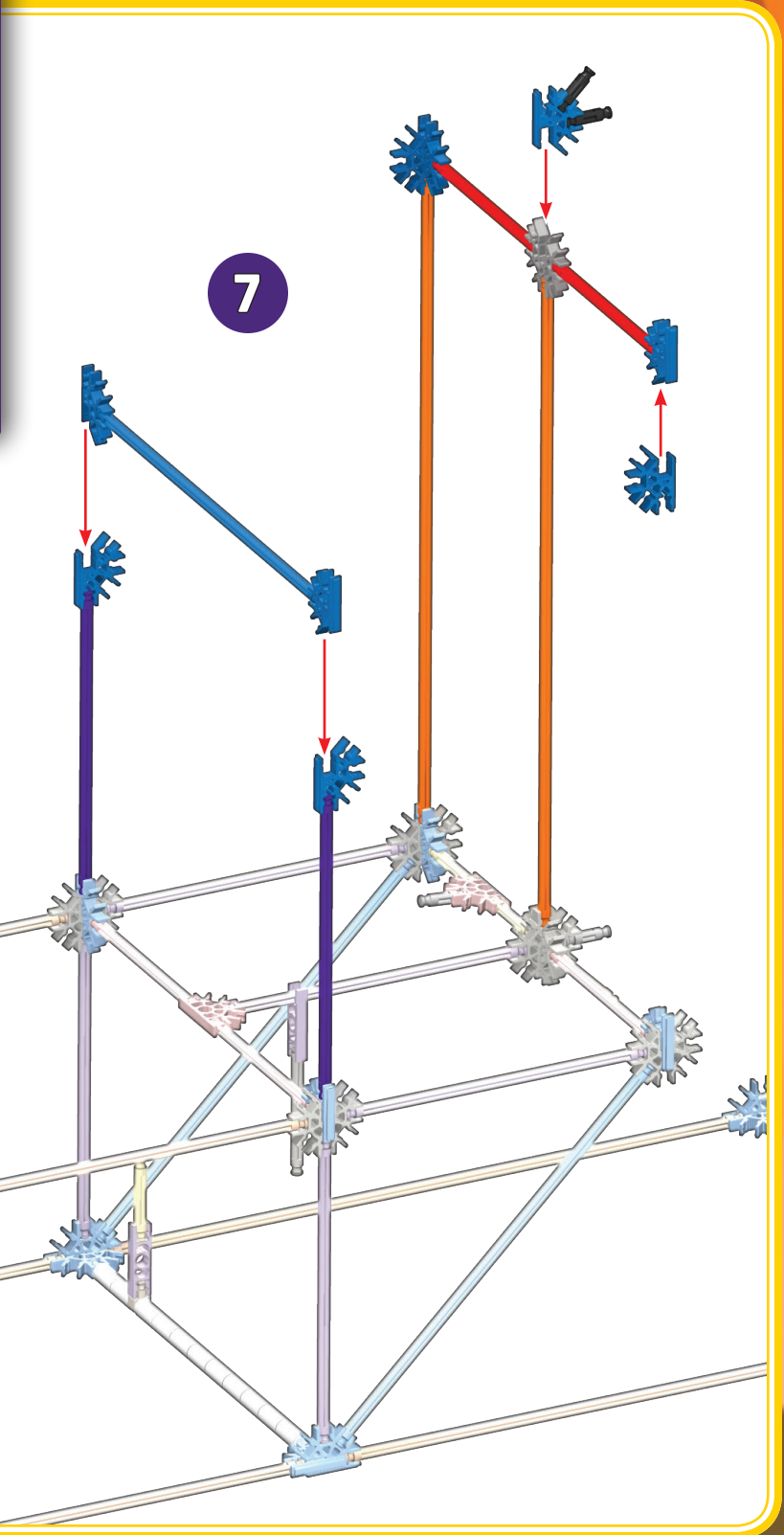
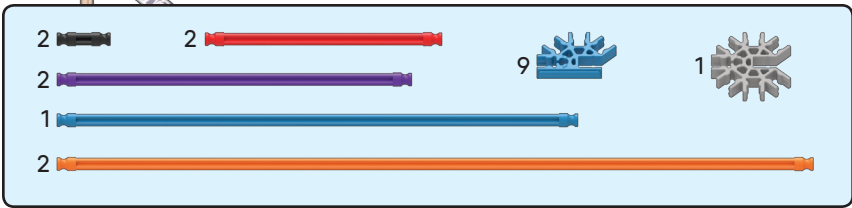

7

1 - 6

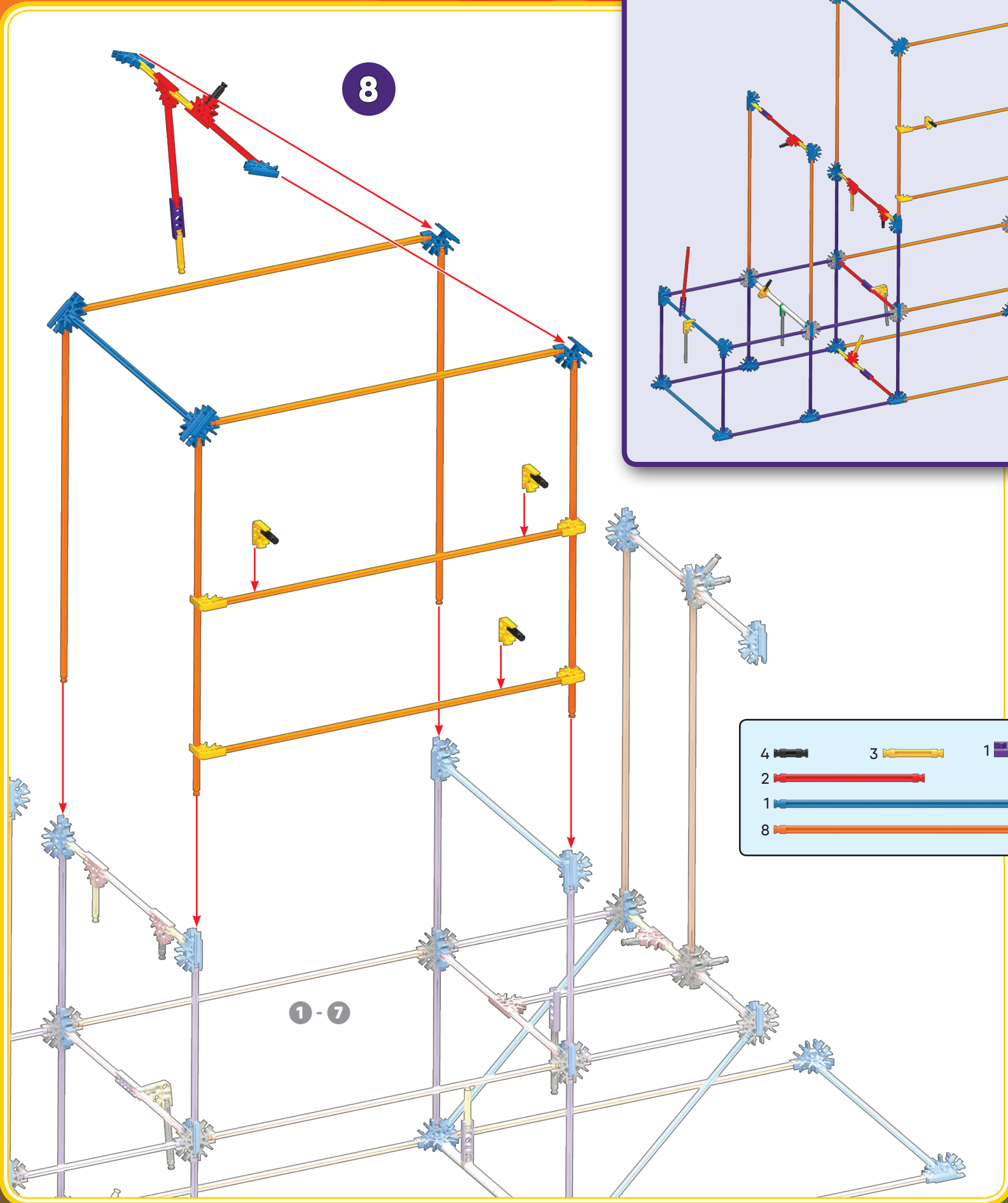

8

1-7

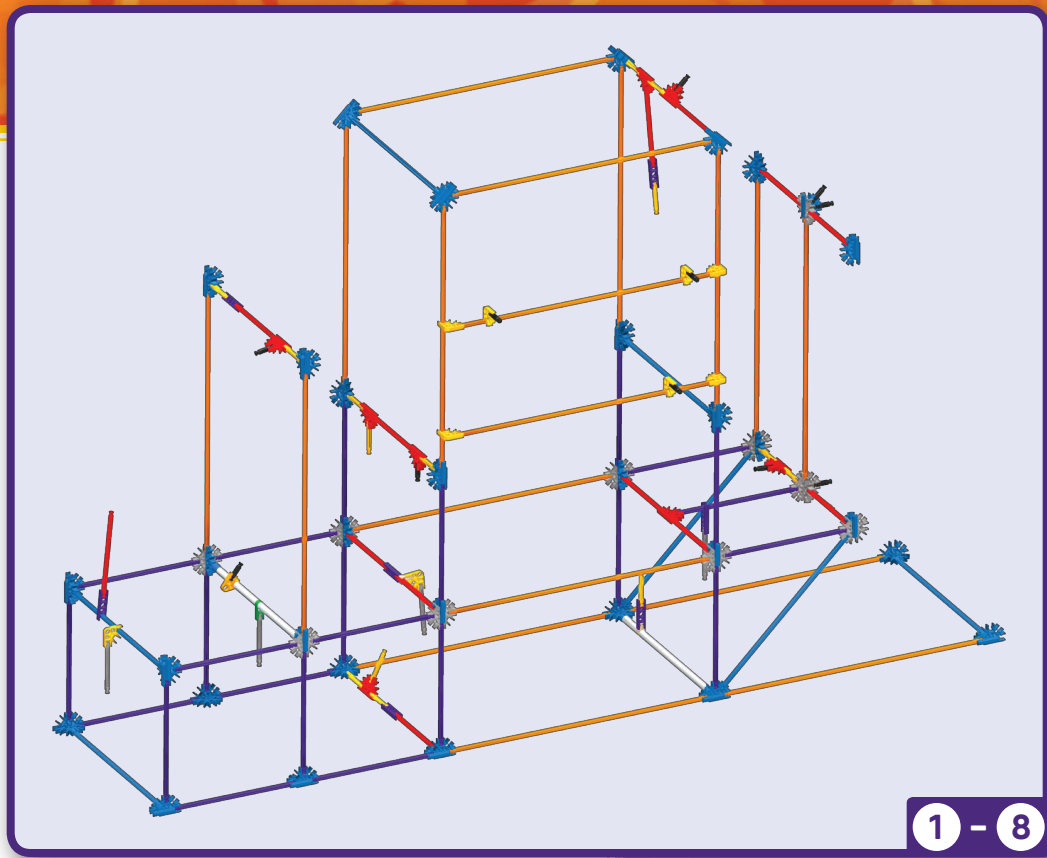

1-8

4		3		1		7		2	
2									
1								8	
8									

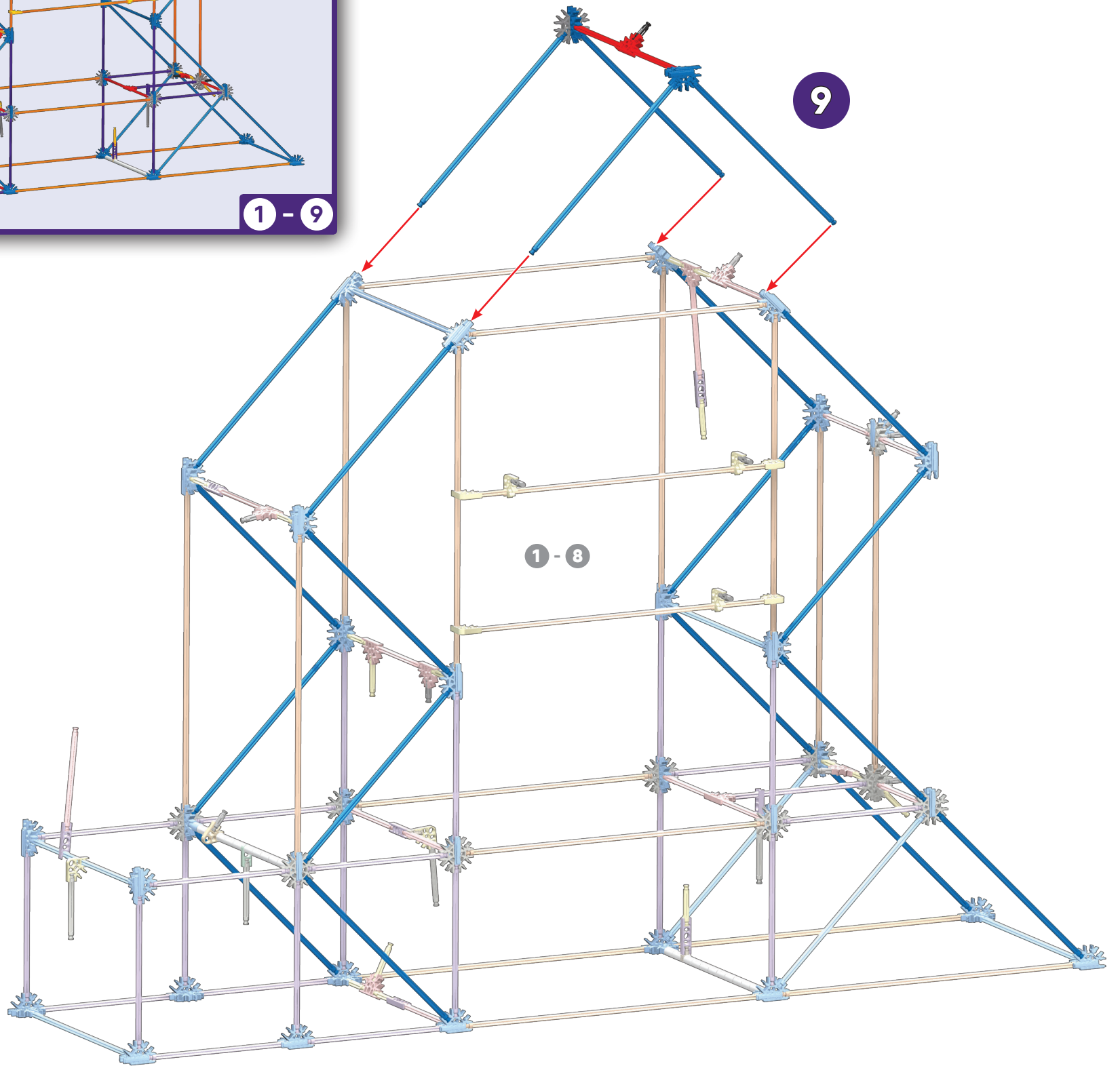
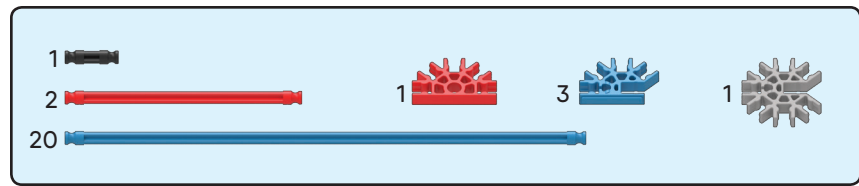
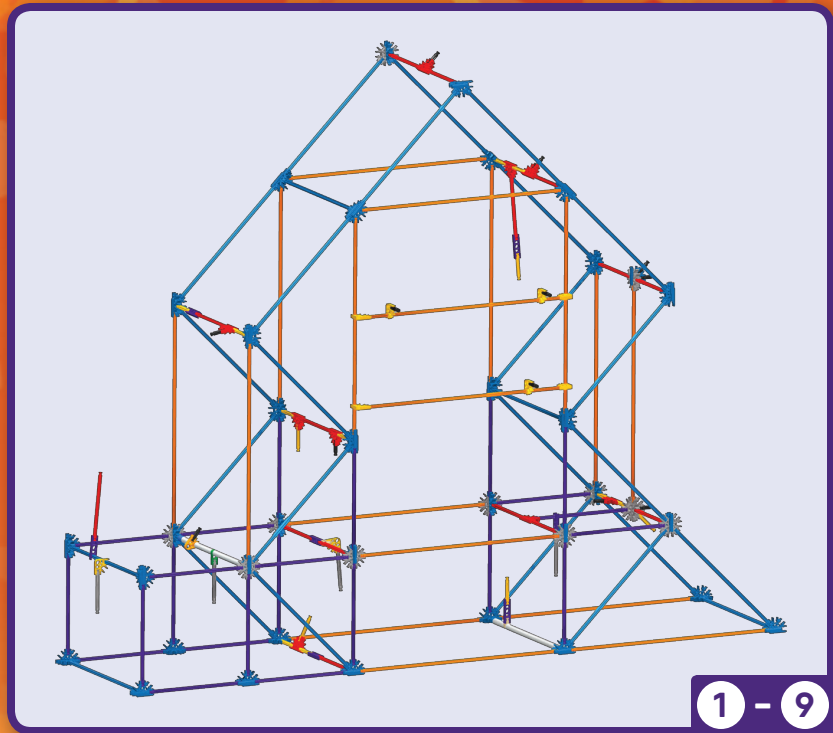

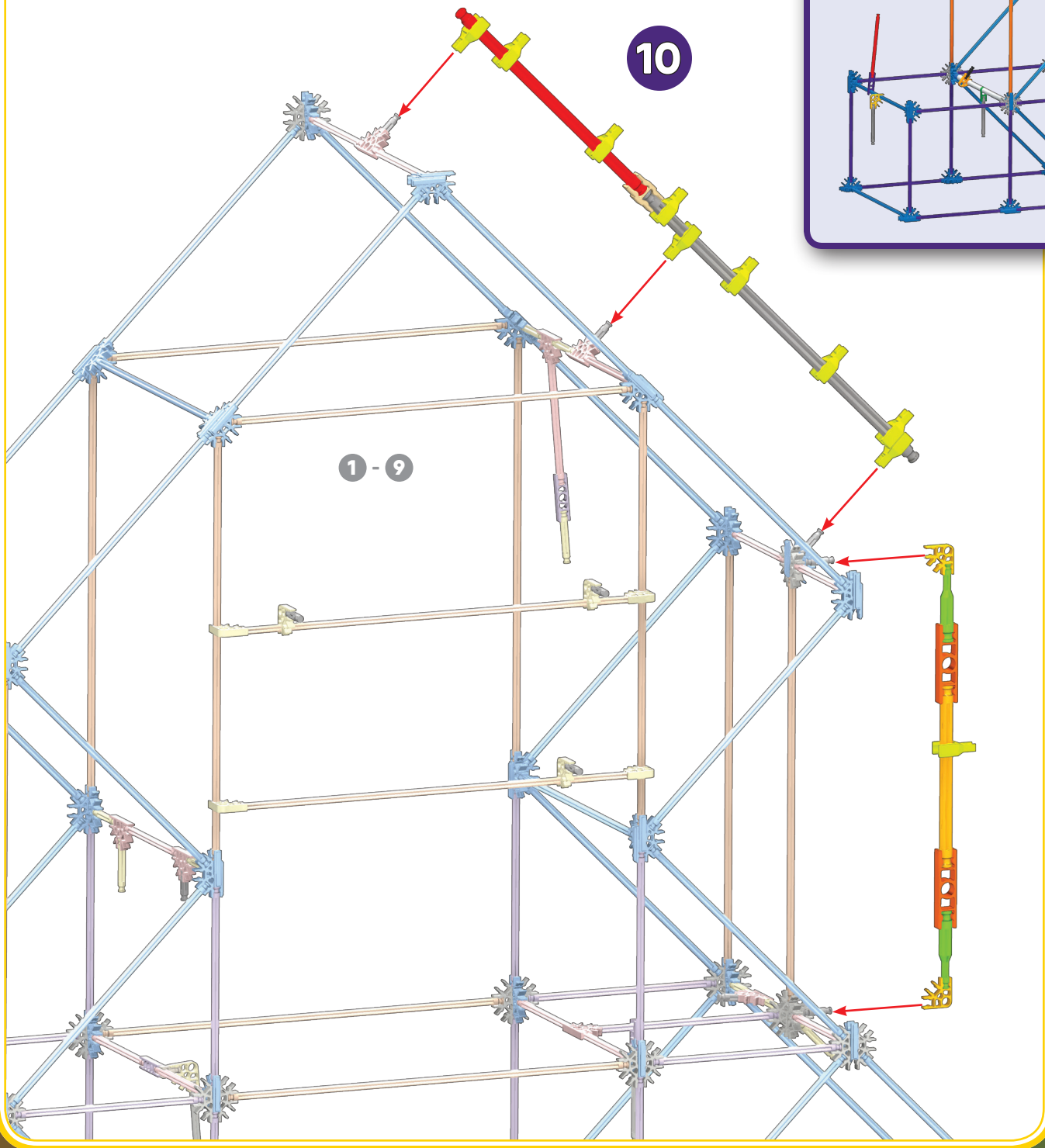
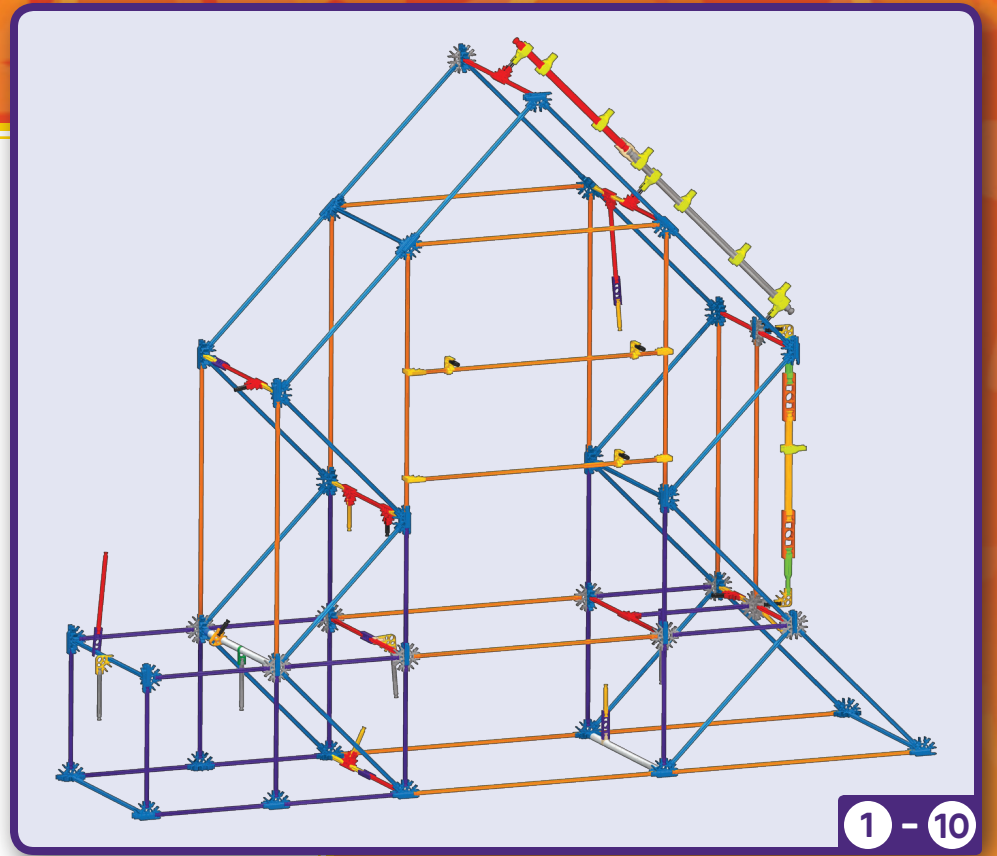
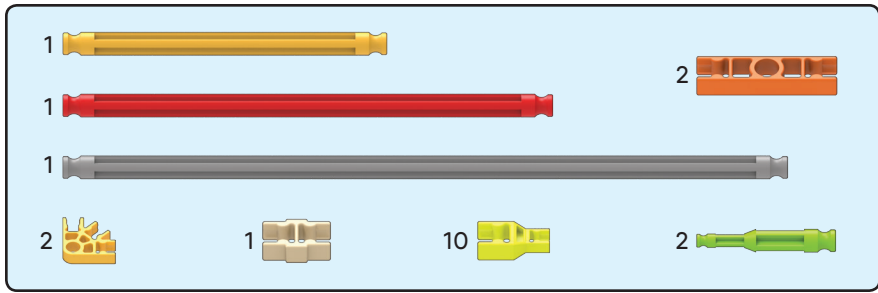

11

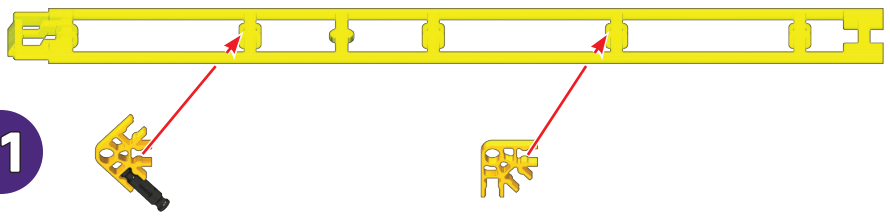

Be sure to push the connectors on firmly until they "click".  
Pousse bien les connecteurs jusqu'à ce qu'ils « cliquent ».

12

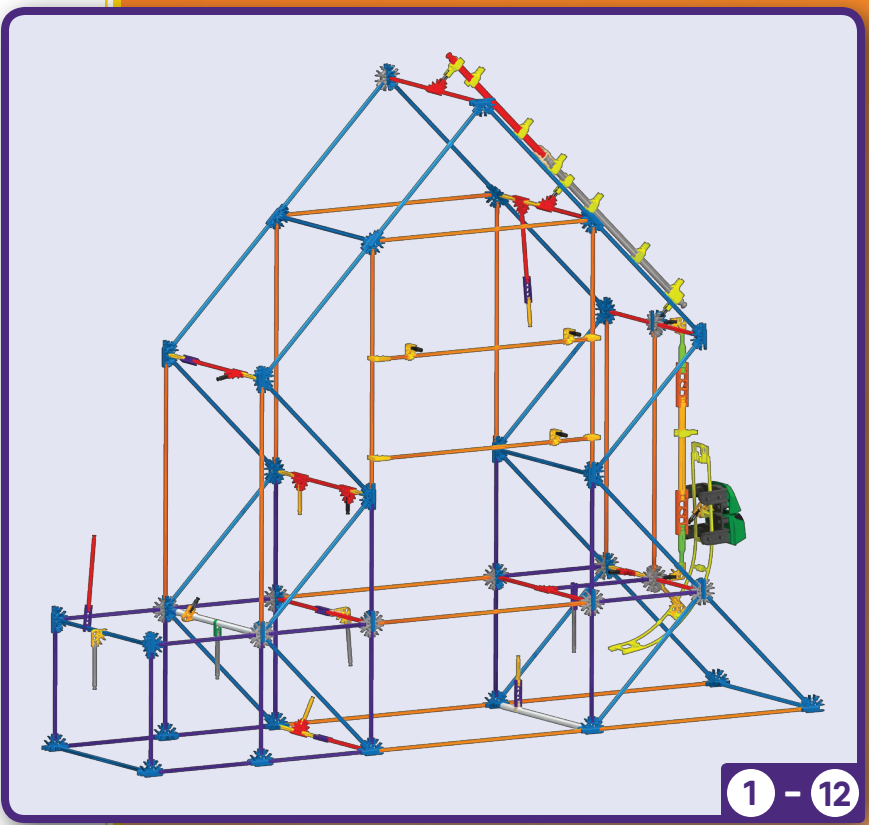
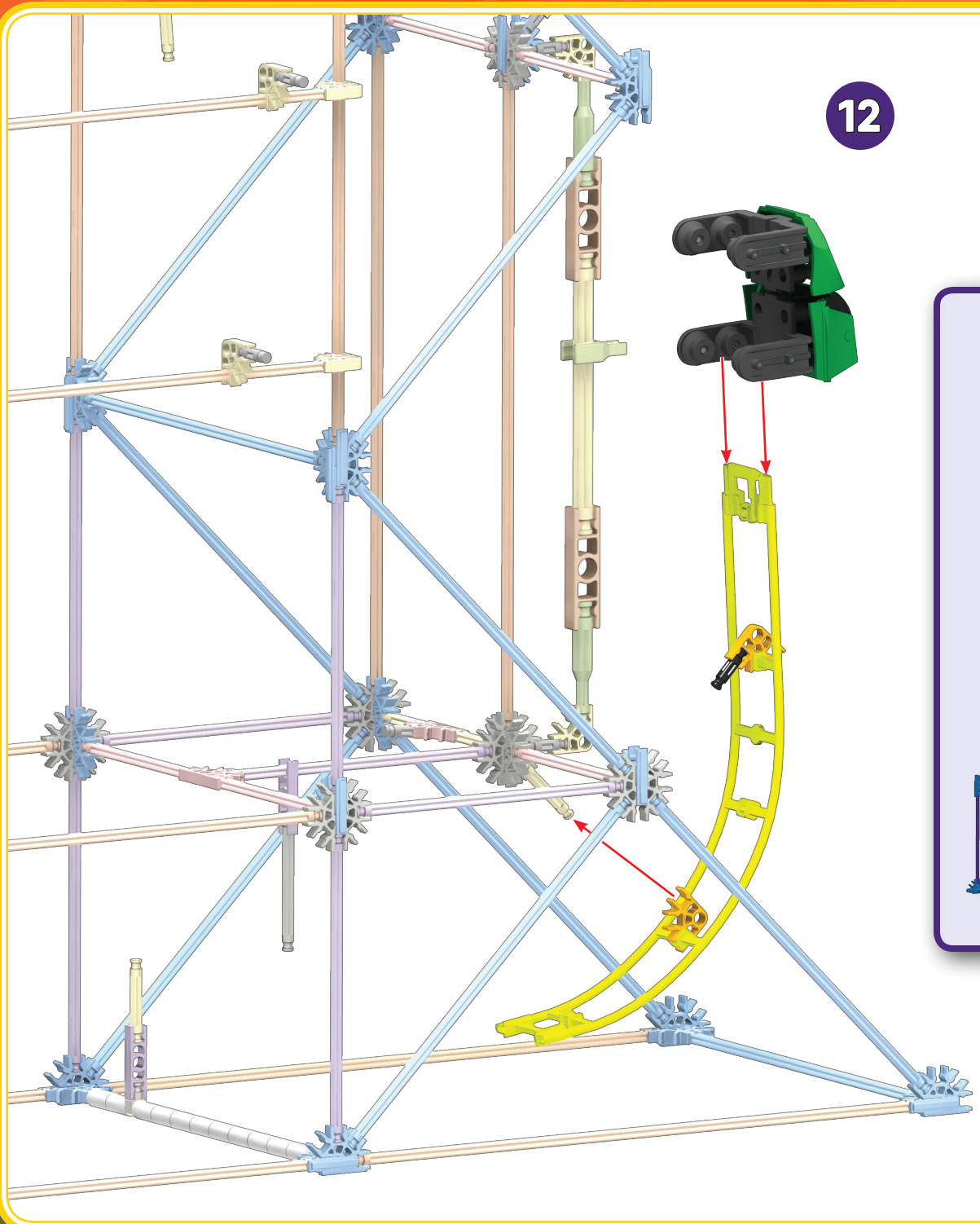

1 - 12

13

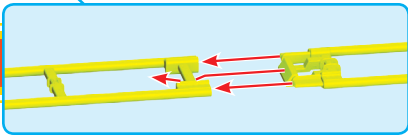
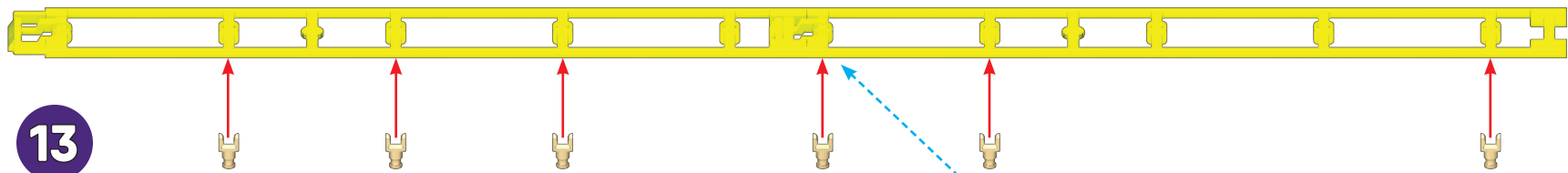

14

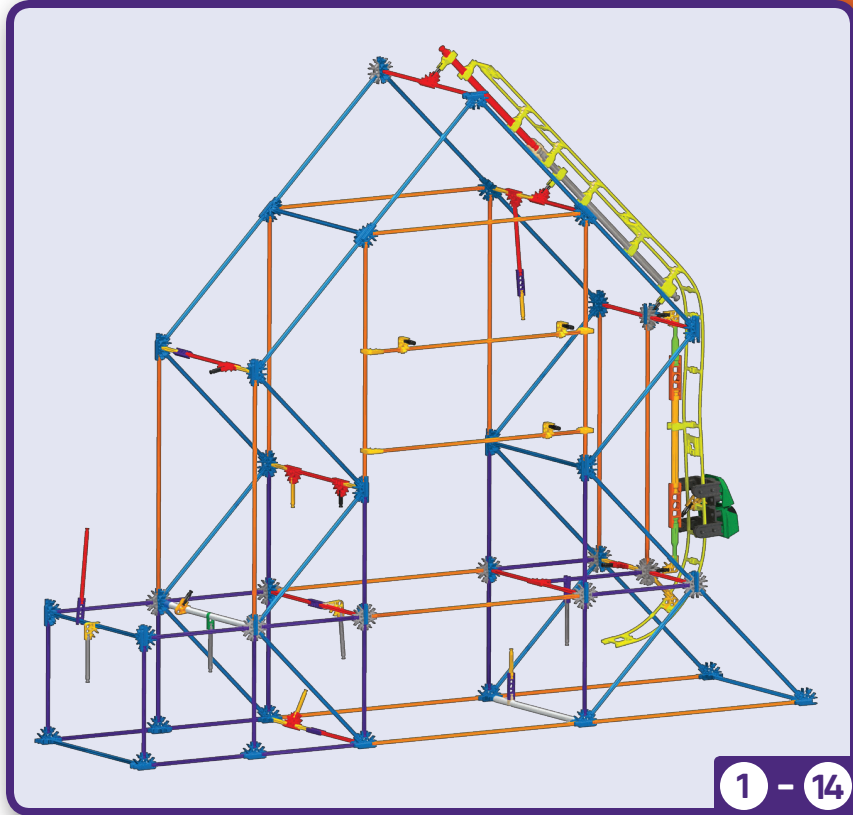
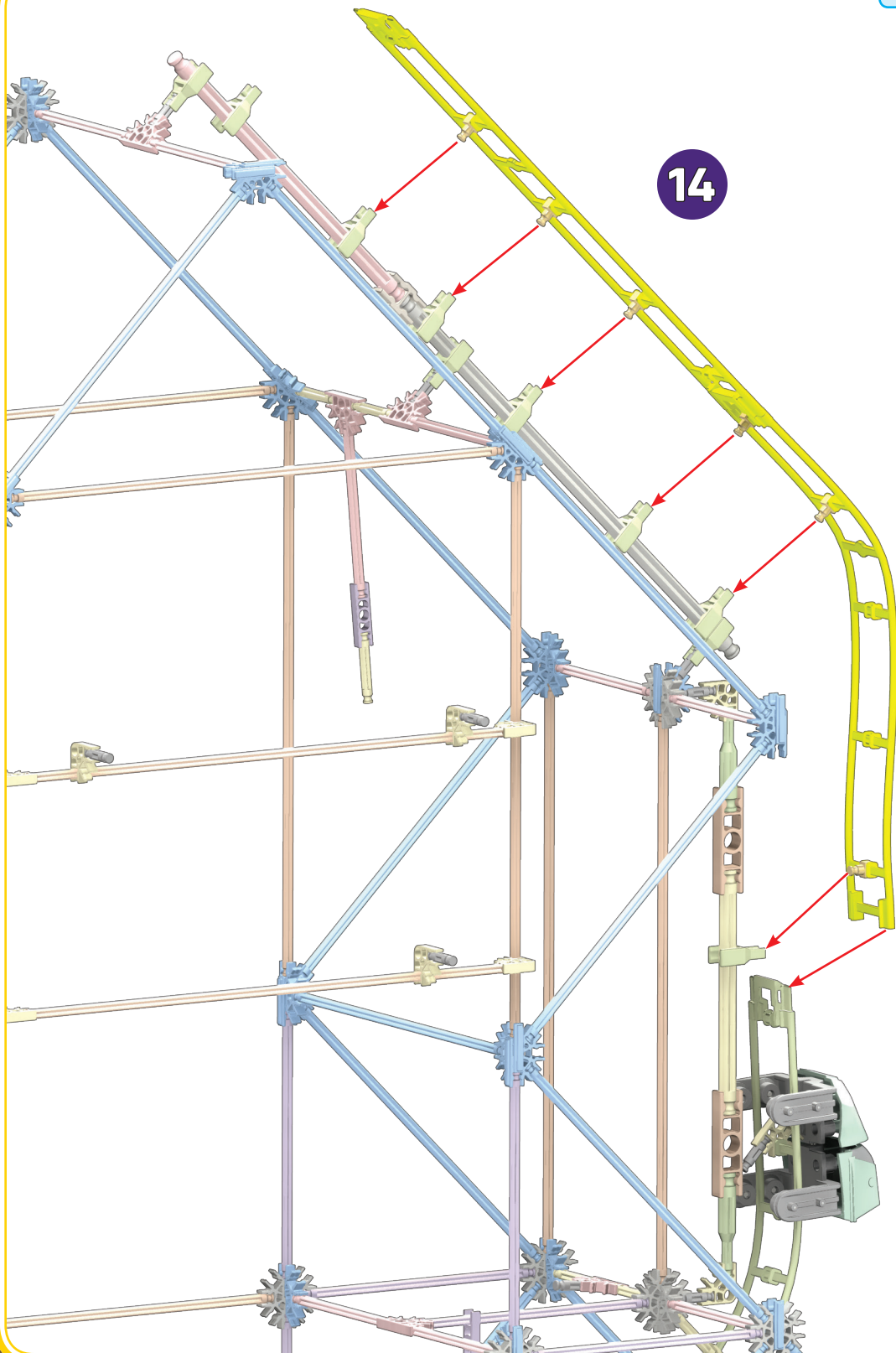

Always join this end of the track to the previous track piece first, then connect the rest of the track to the tower.

Toujours joindre à cette extrémité de la voie à la pièce de la piste précédente, puis connecter le reste de la piste à la tour.



15

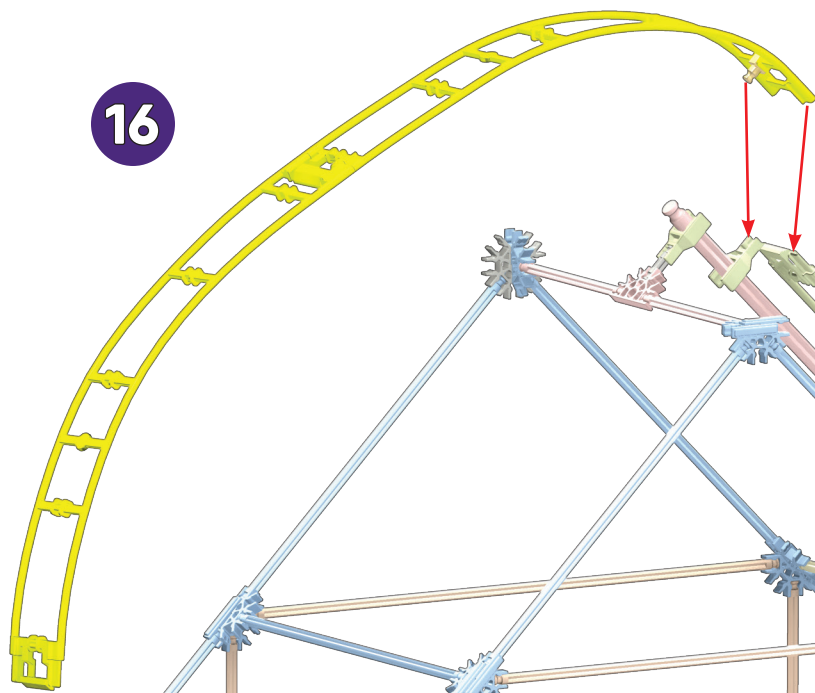

16

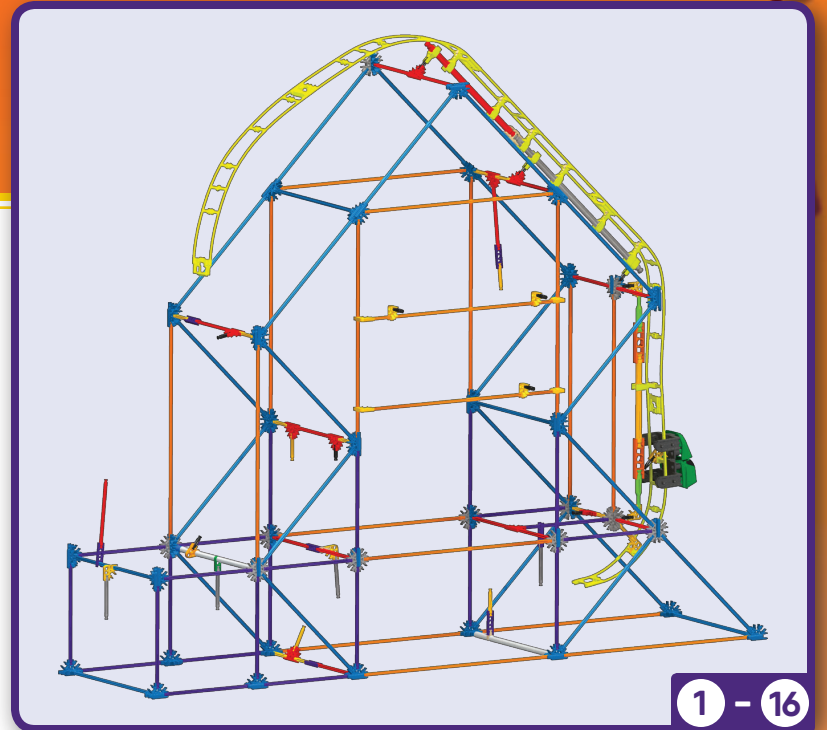

1 - 16

17

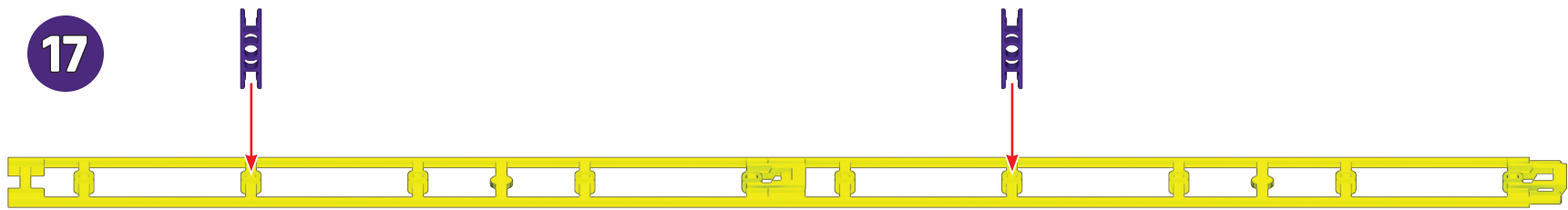

18

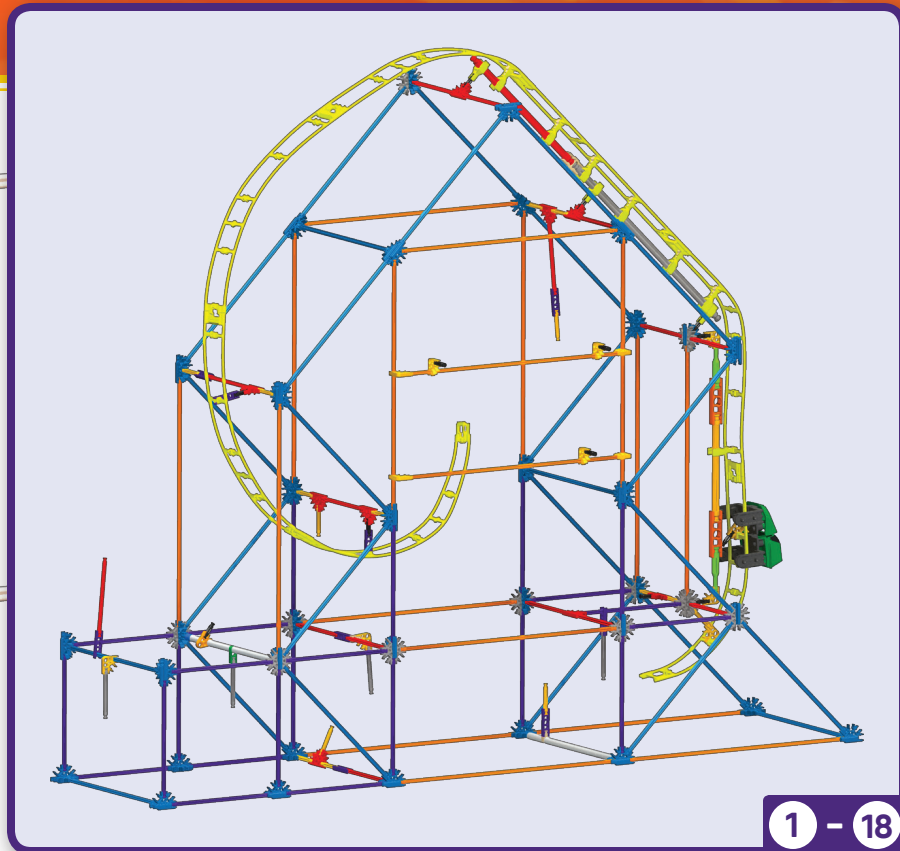
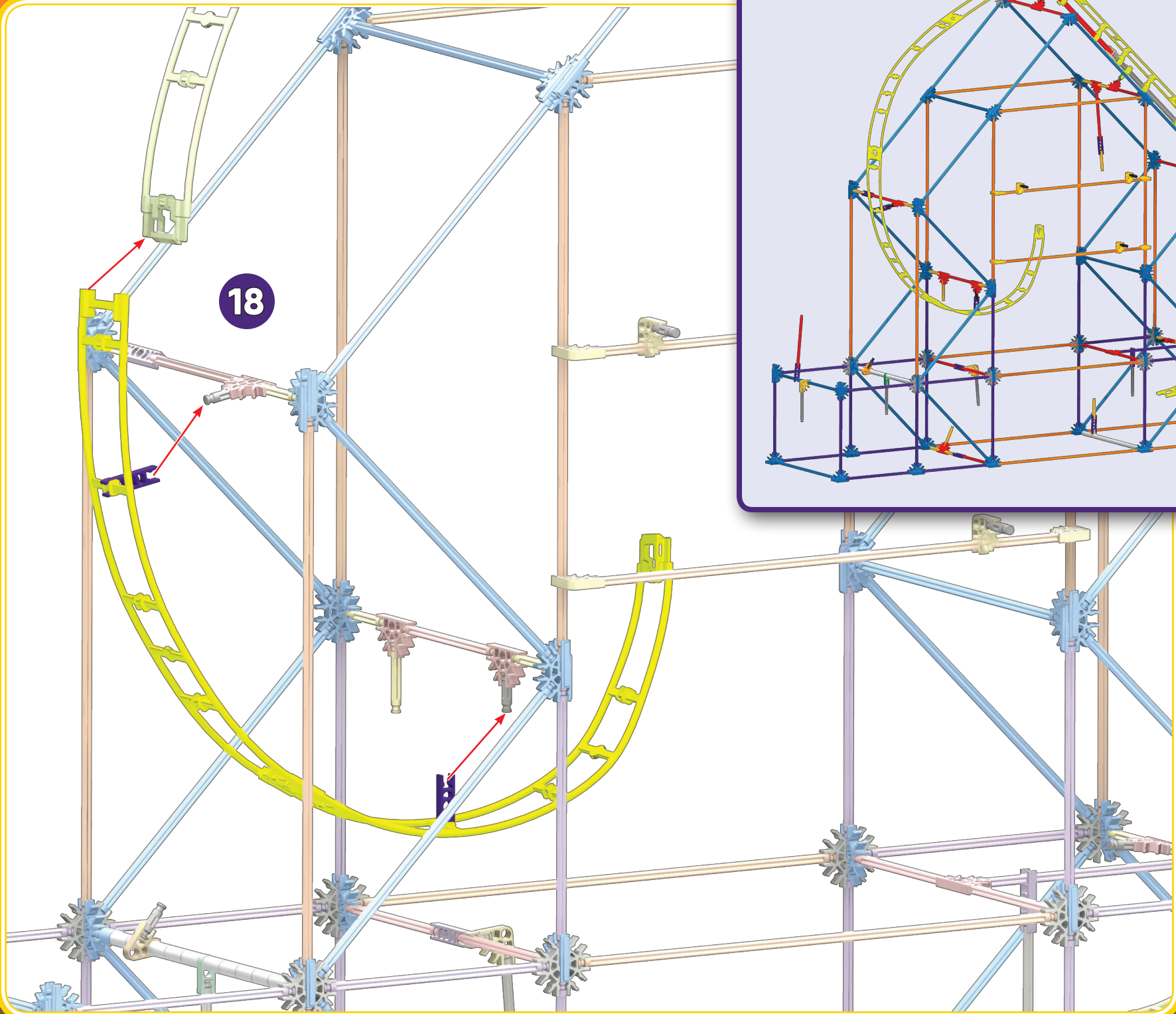

1 - 18



19

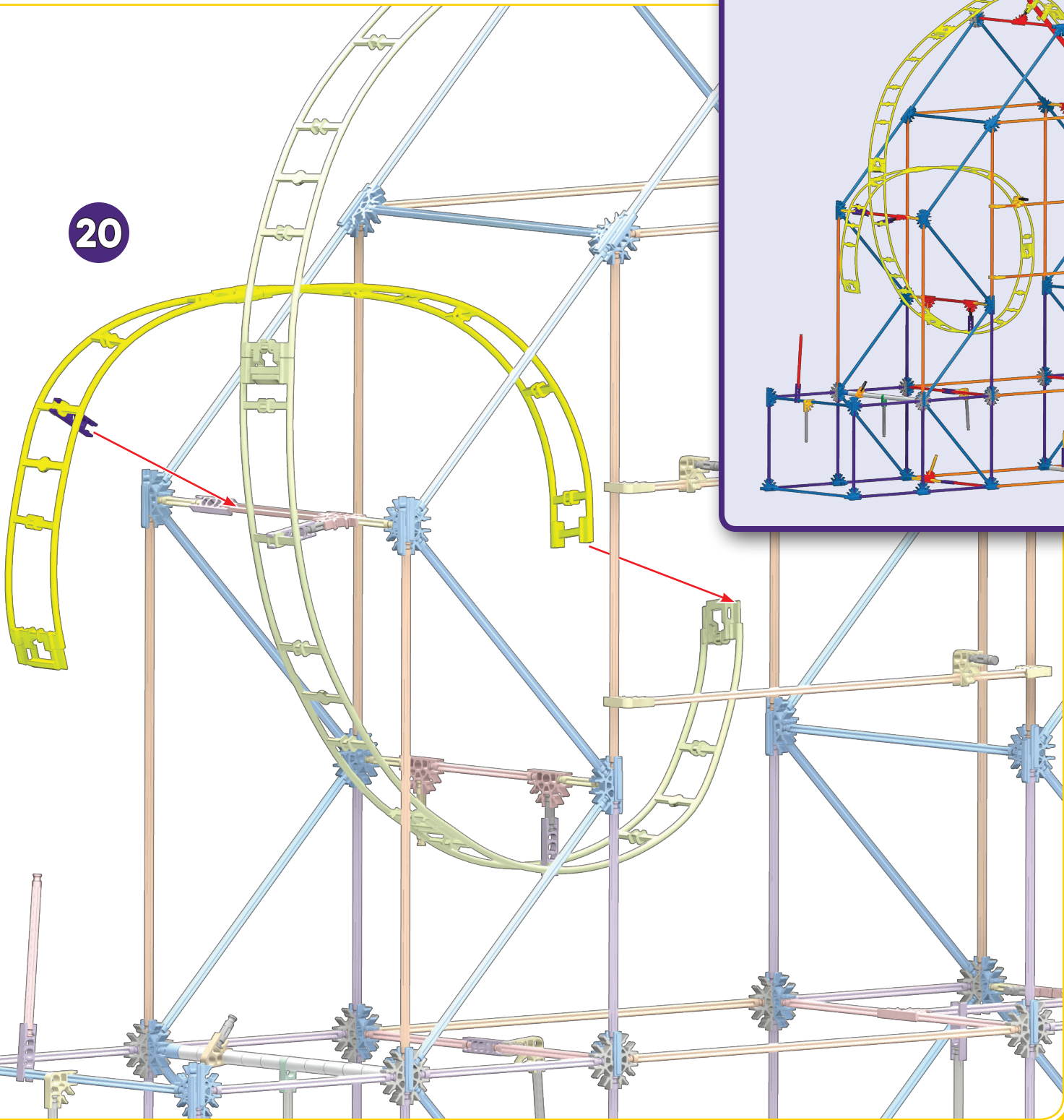

20

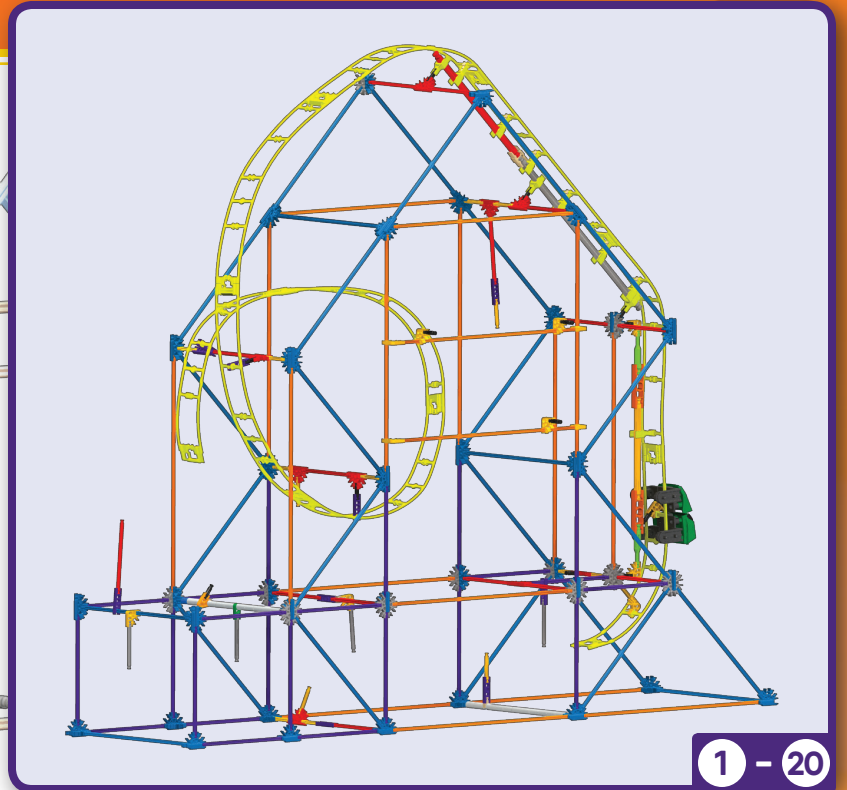

1 - 20

21

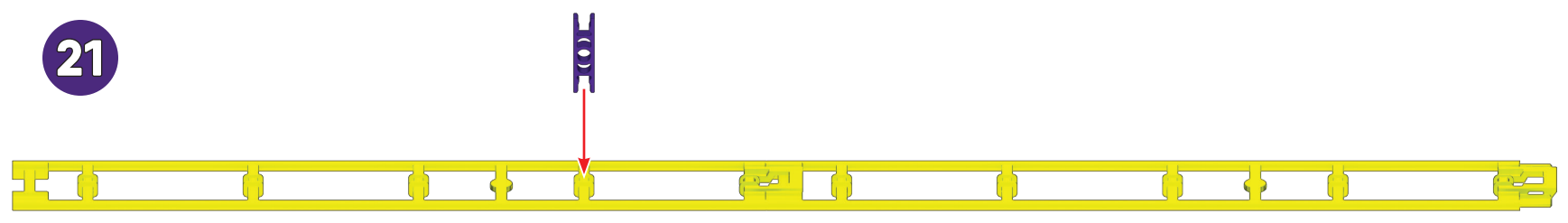

22

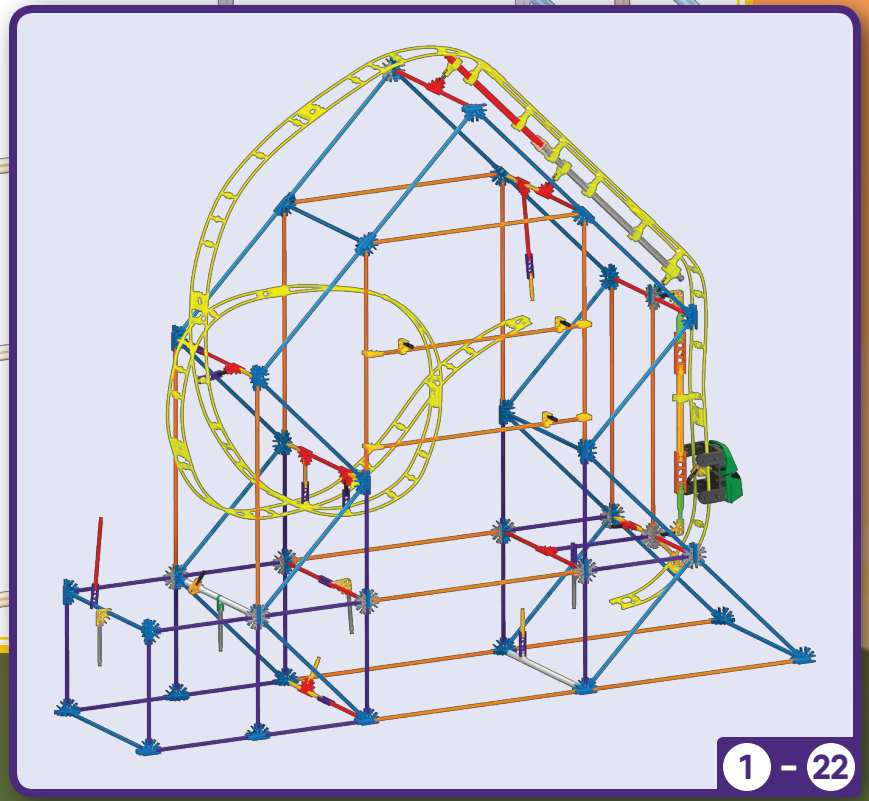
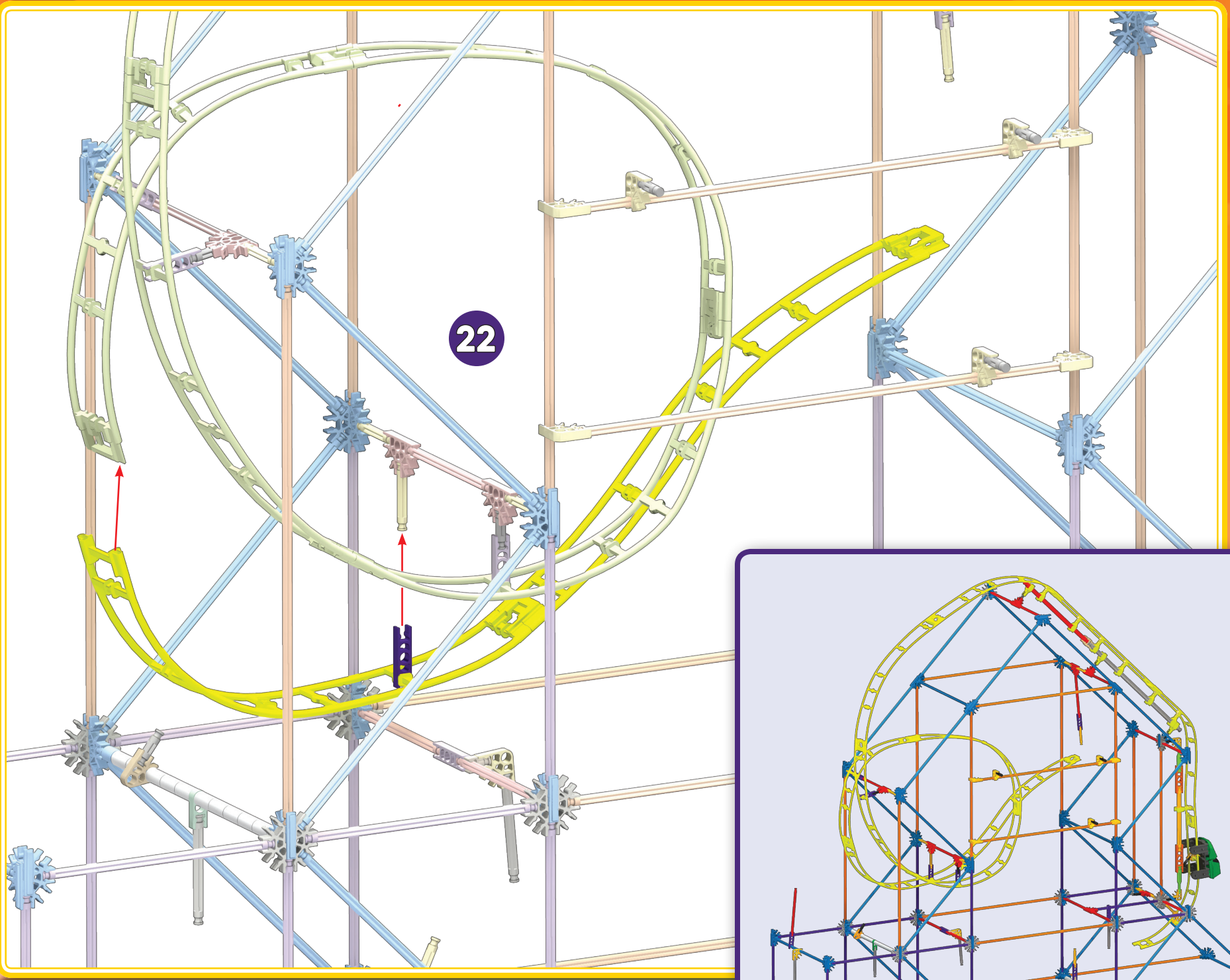

1 - 22

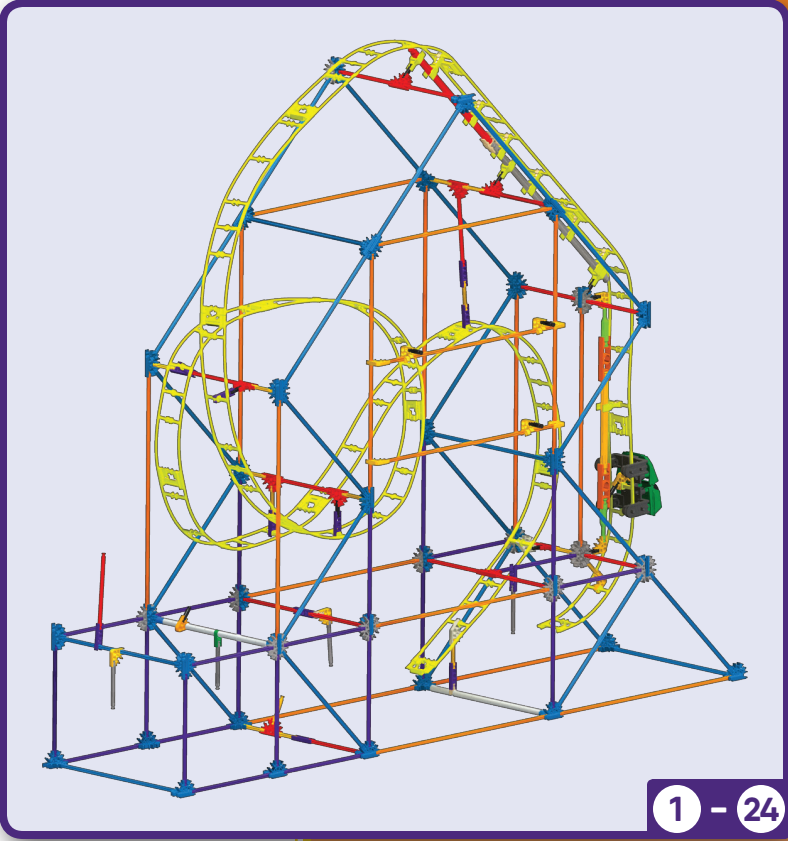
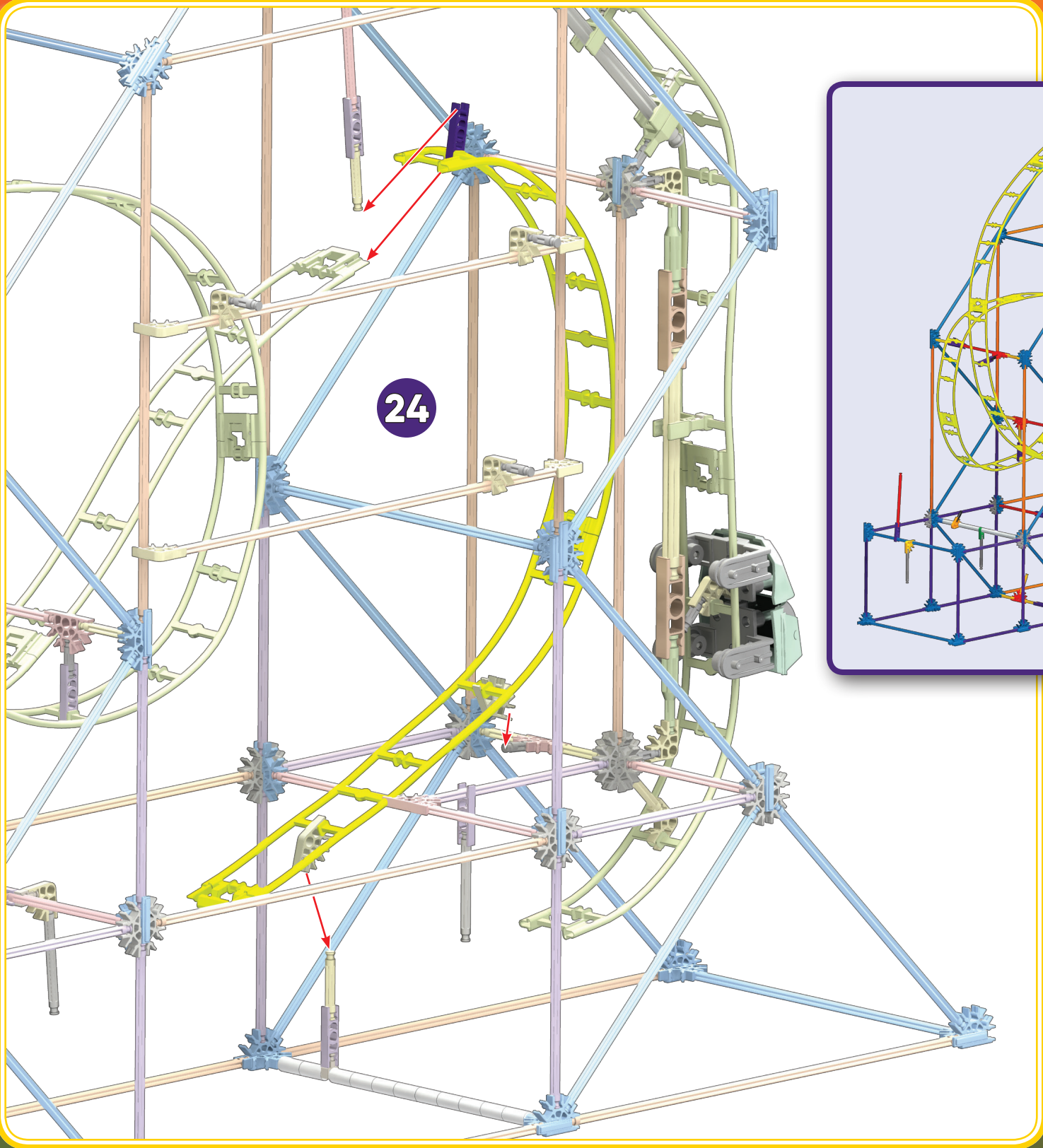
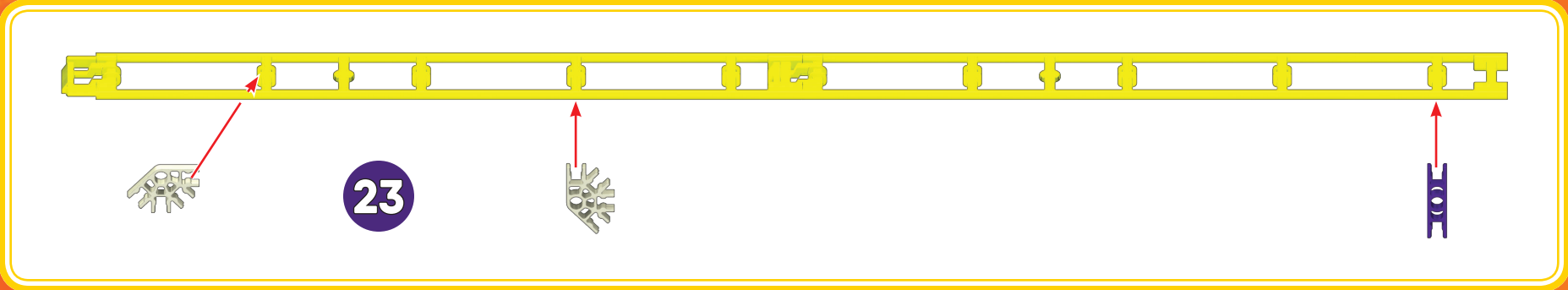



25



26

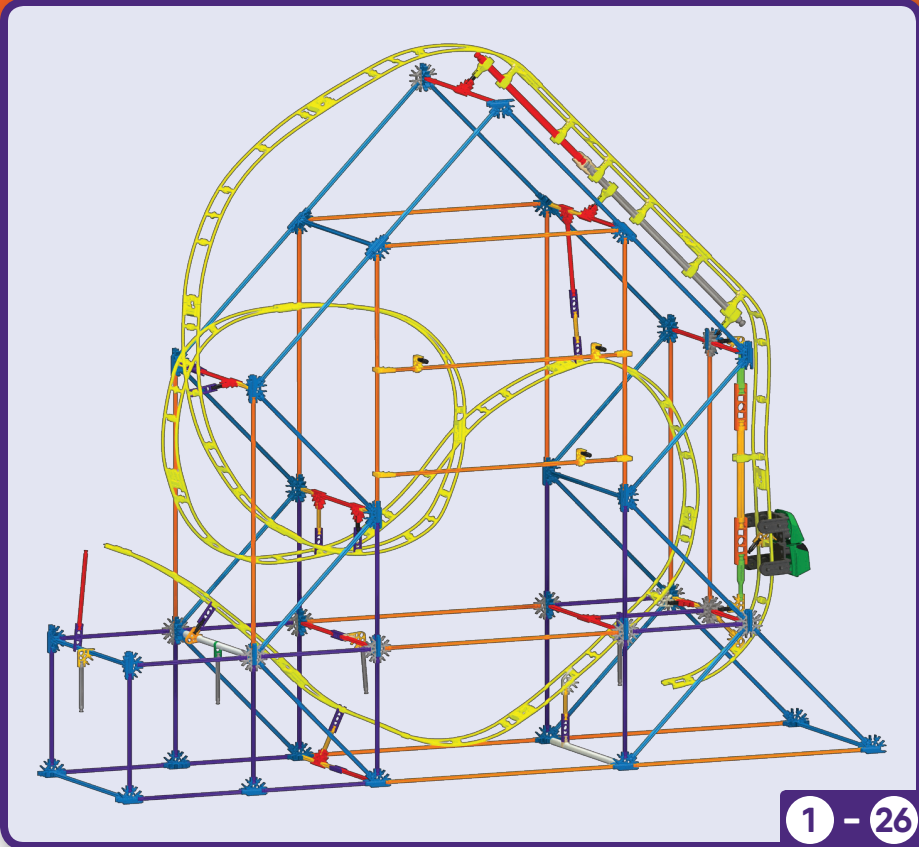
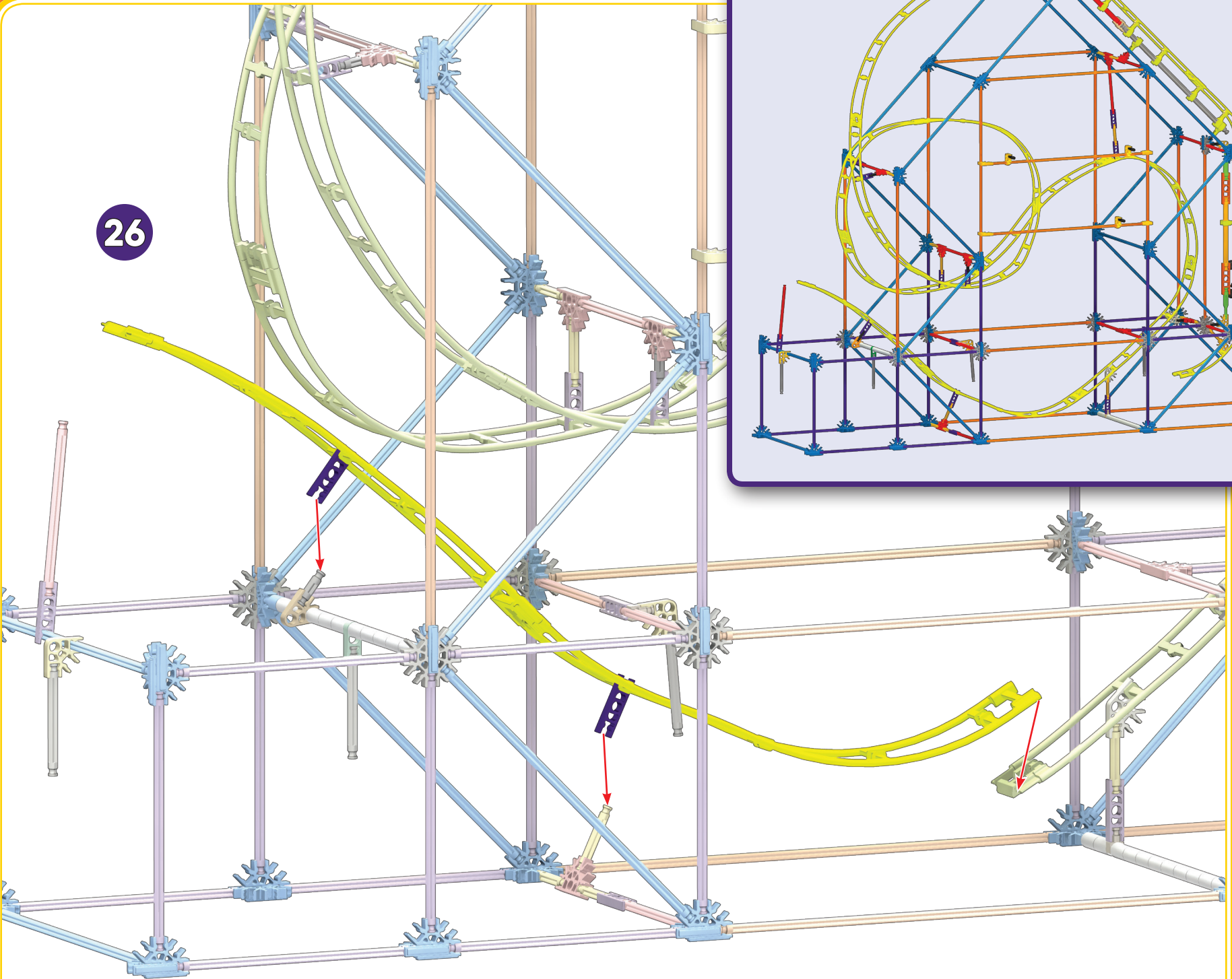

1 - 26

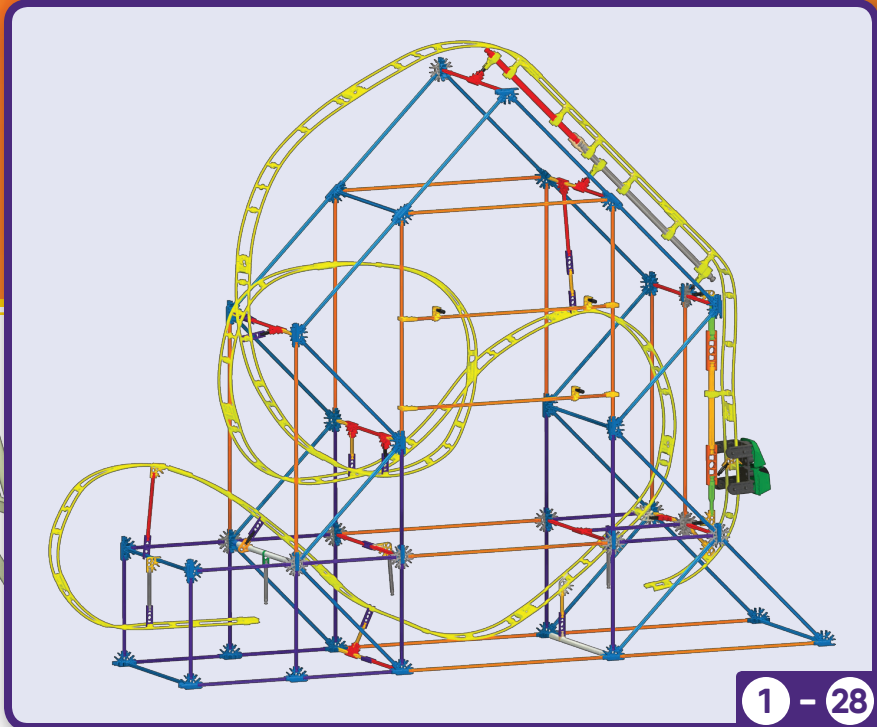
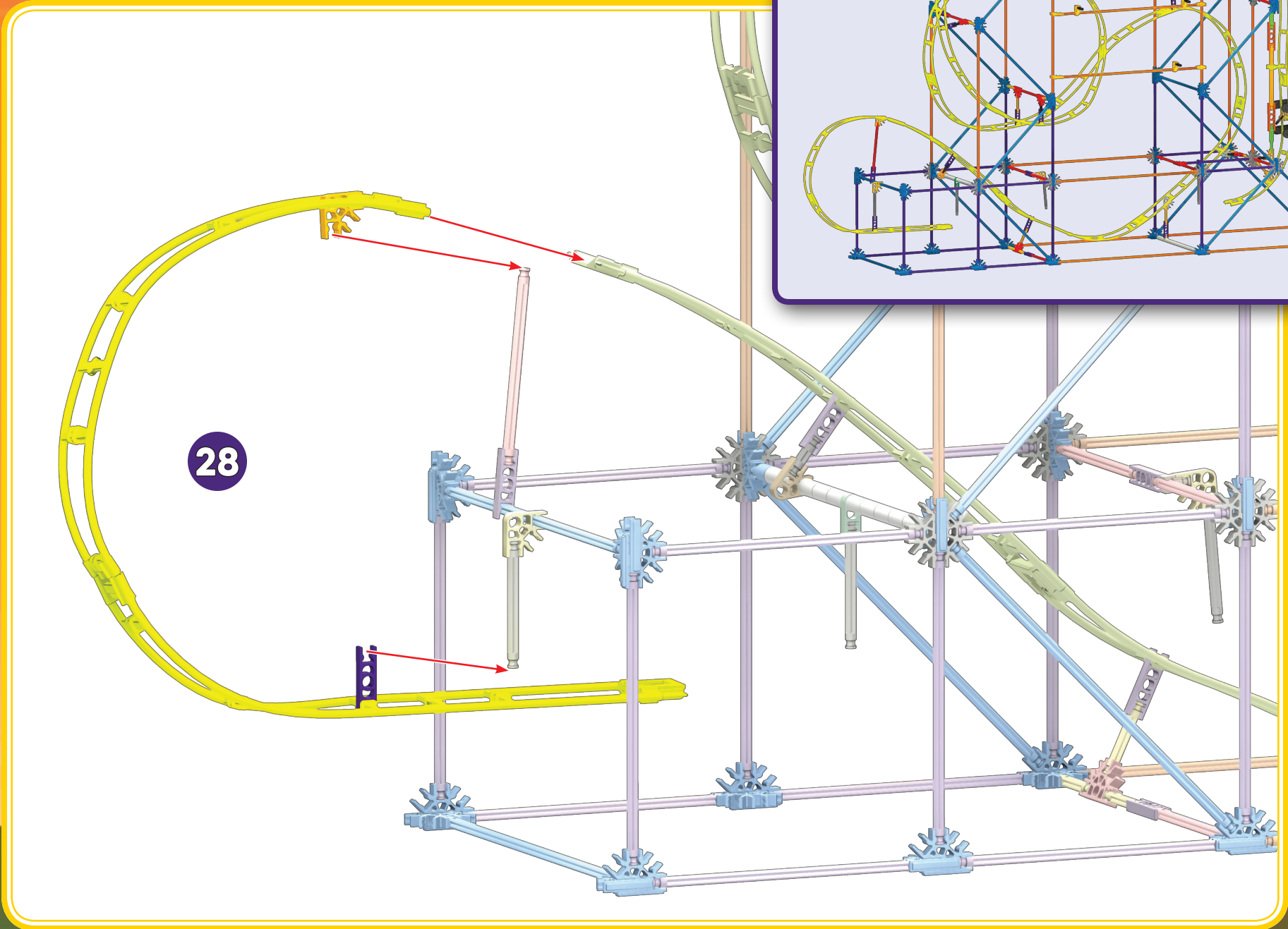
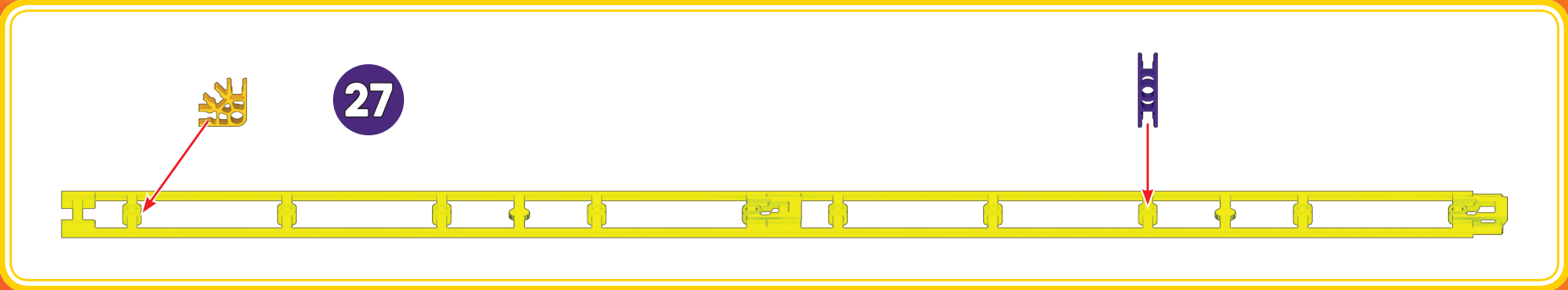

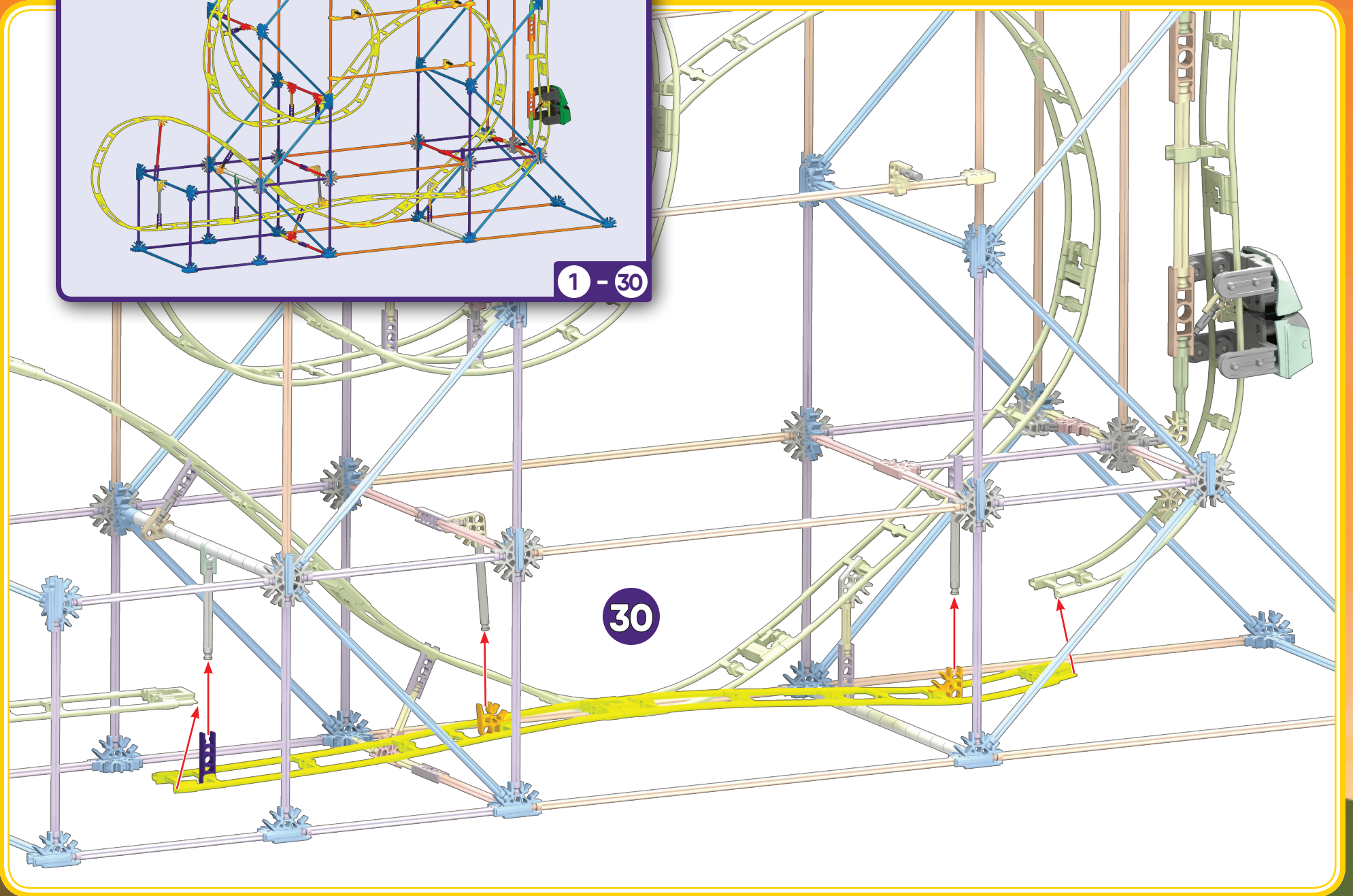
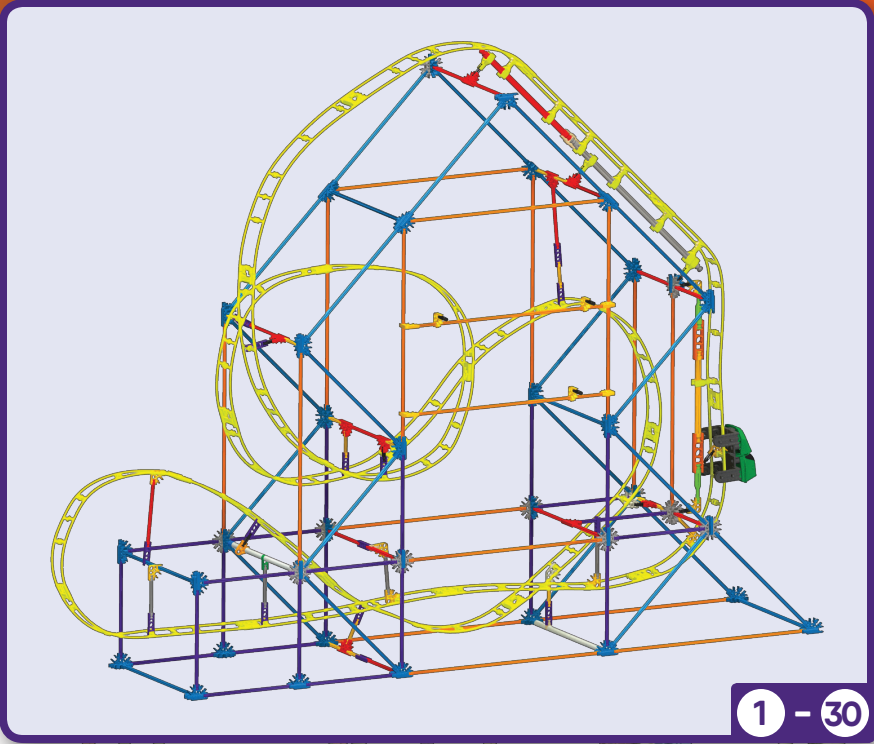
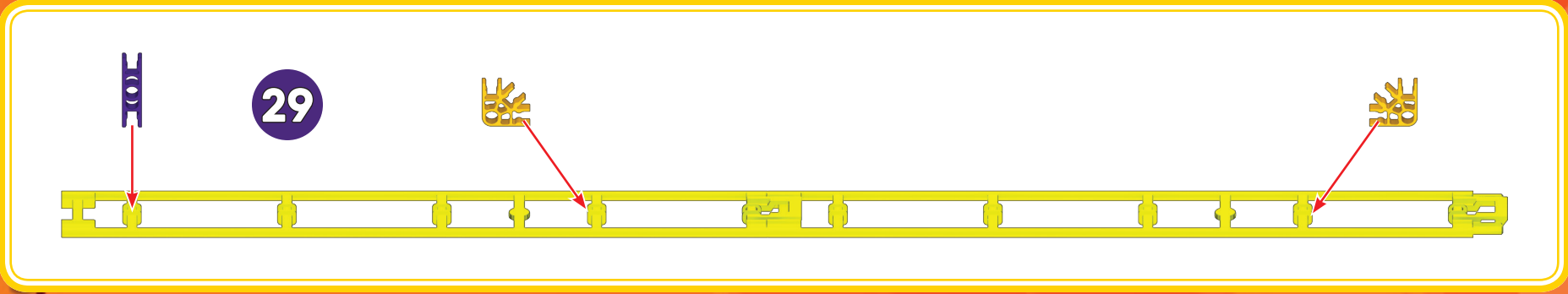

31

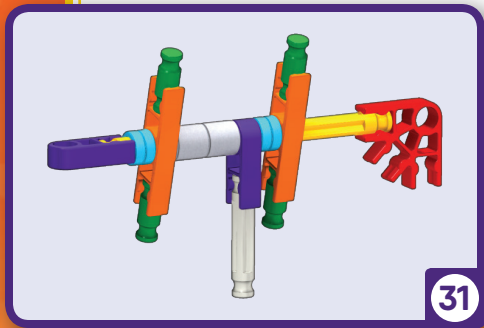
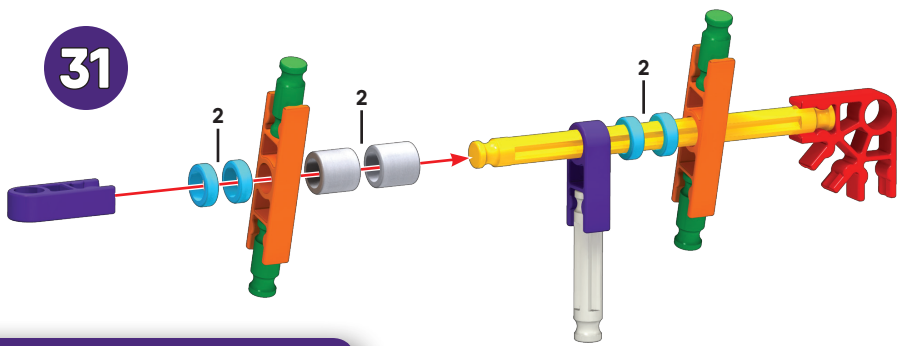

31

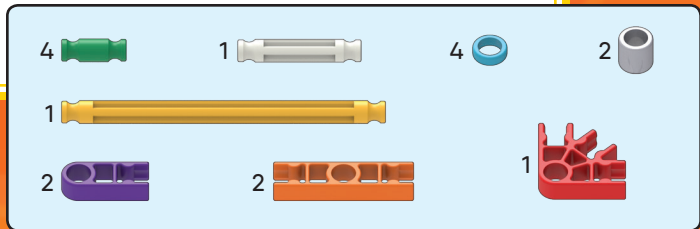

33

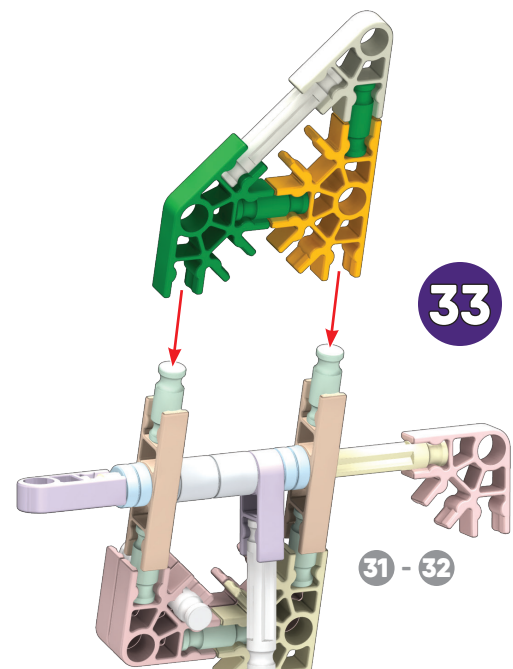

31 - 32

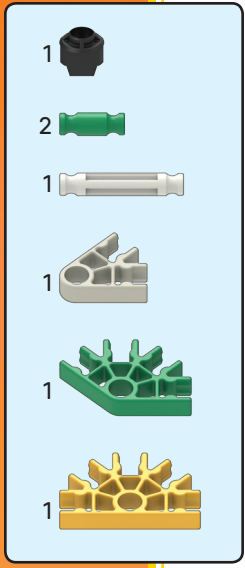

32

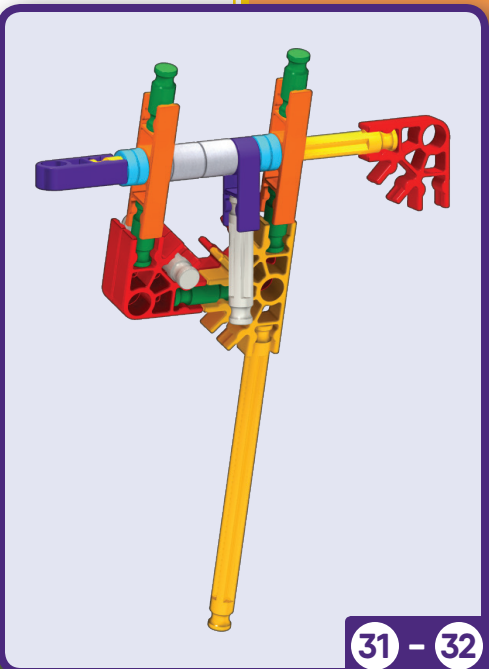
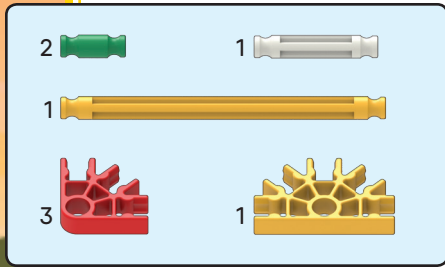
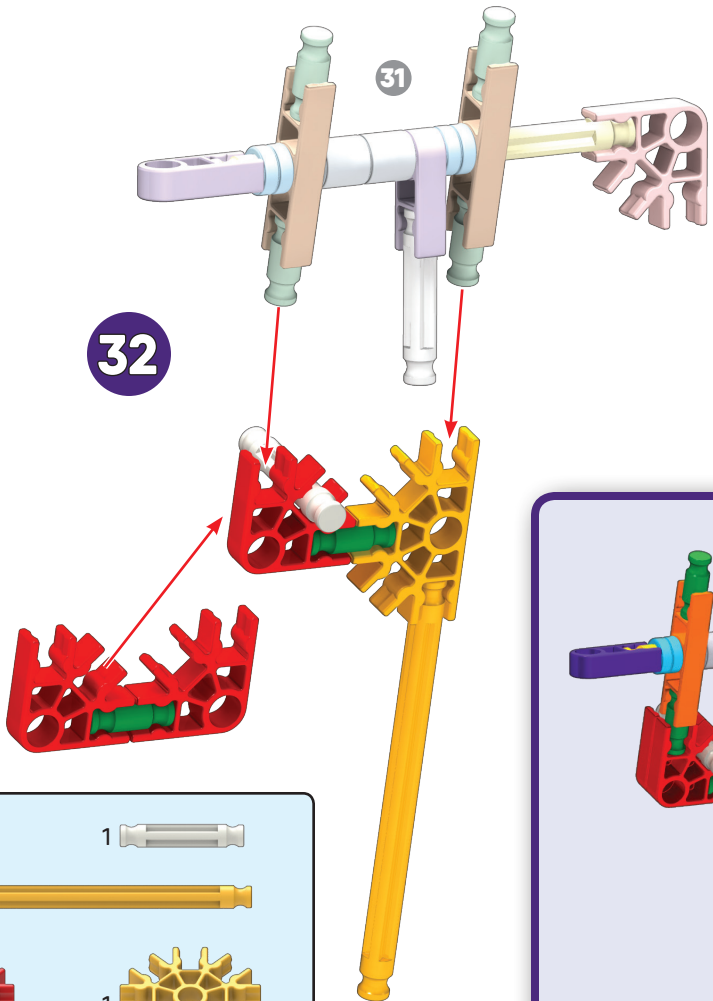

31 - 32

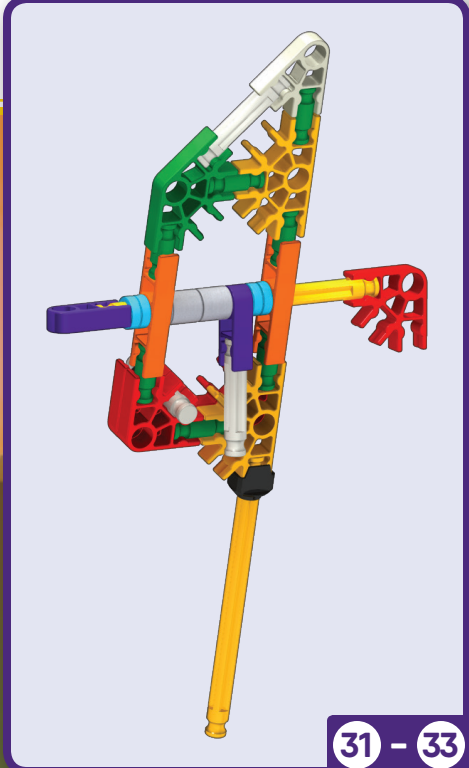

31 - 33

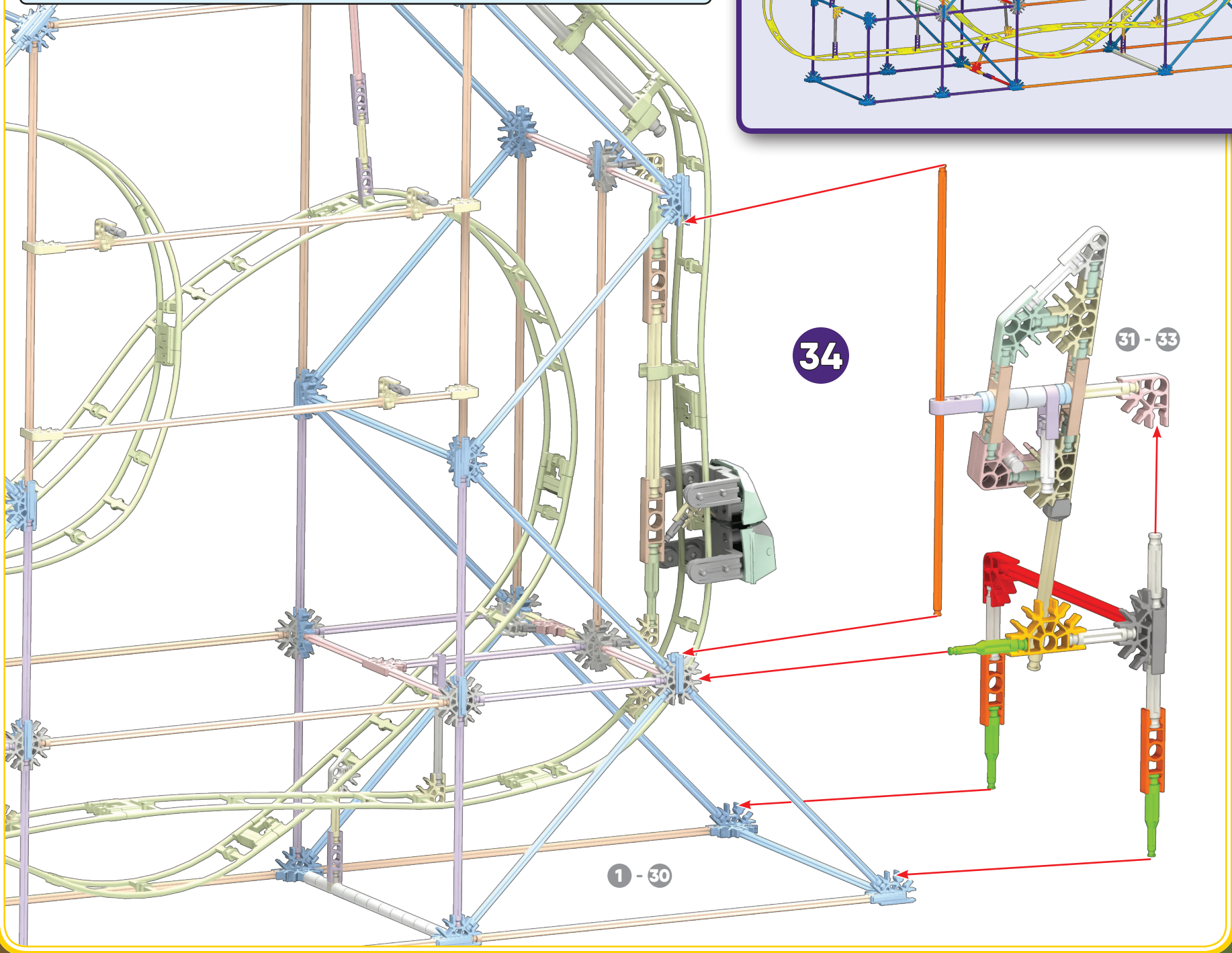
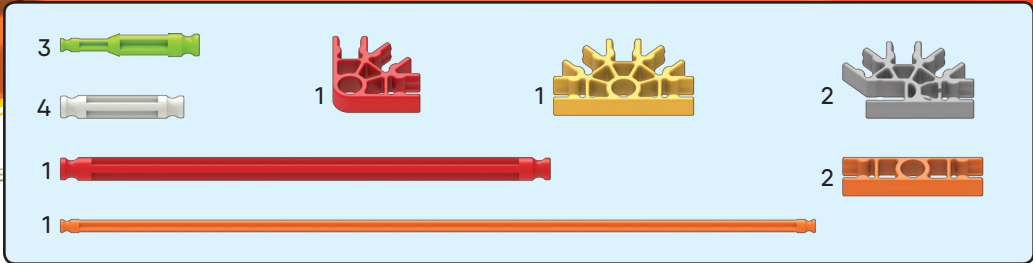
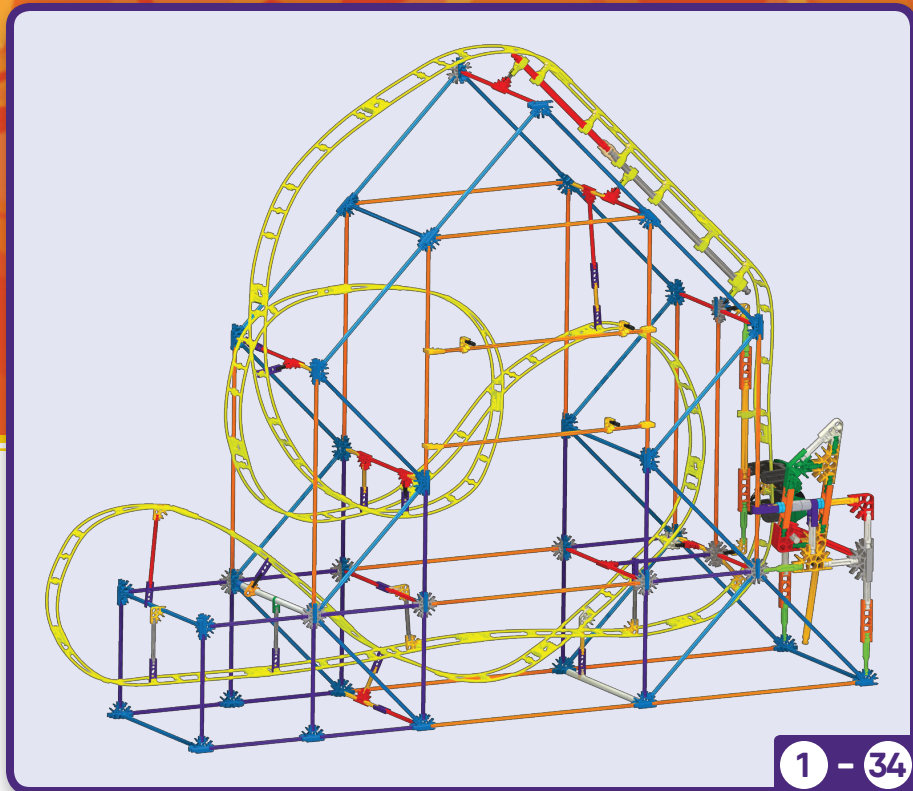

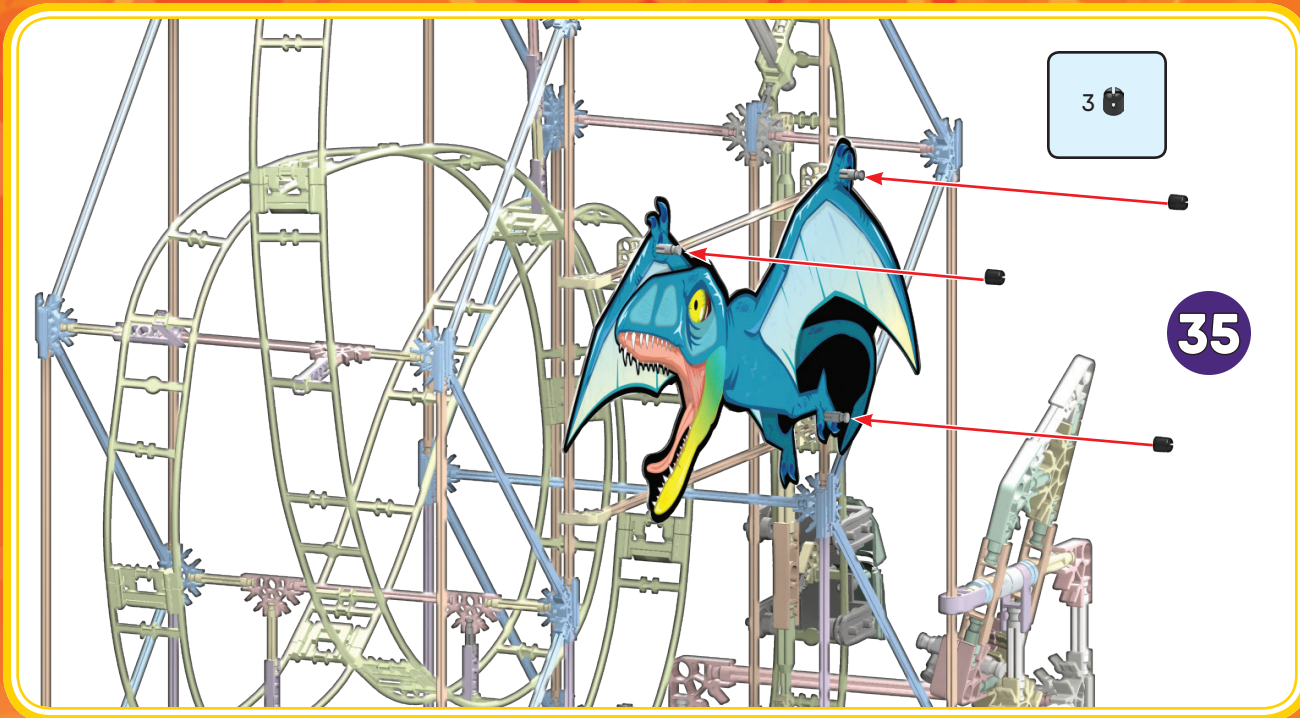

**NOW GRAB YOUR  
DEVICE, OPEN THE APP,  
AND RIDE IT!**

**MAINTENANT, PRENEZ  
VOTRE APPAREIL,  
OUVREZ L'APPLICATION  
ET MONTEZ!**

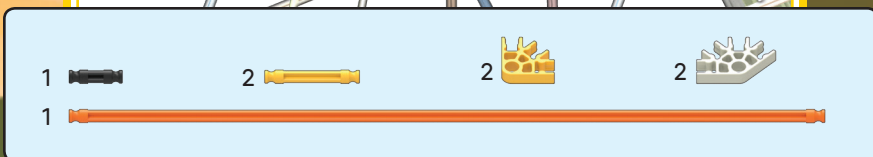
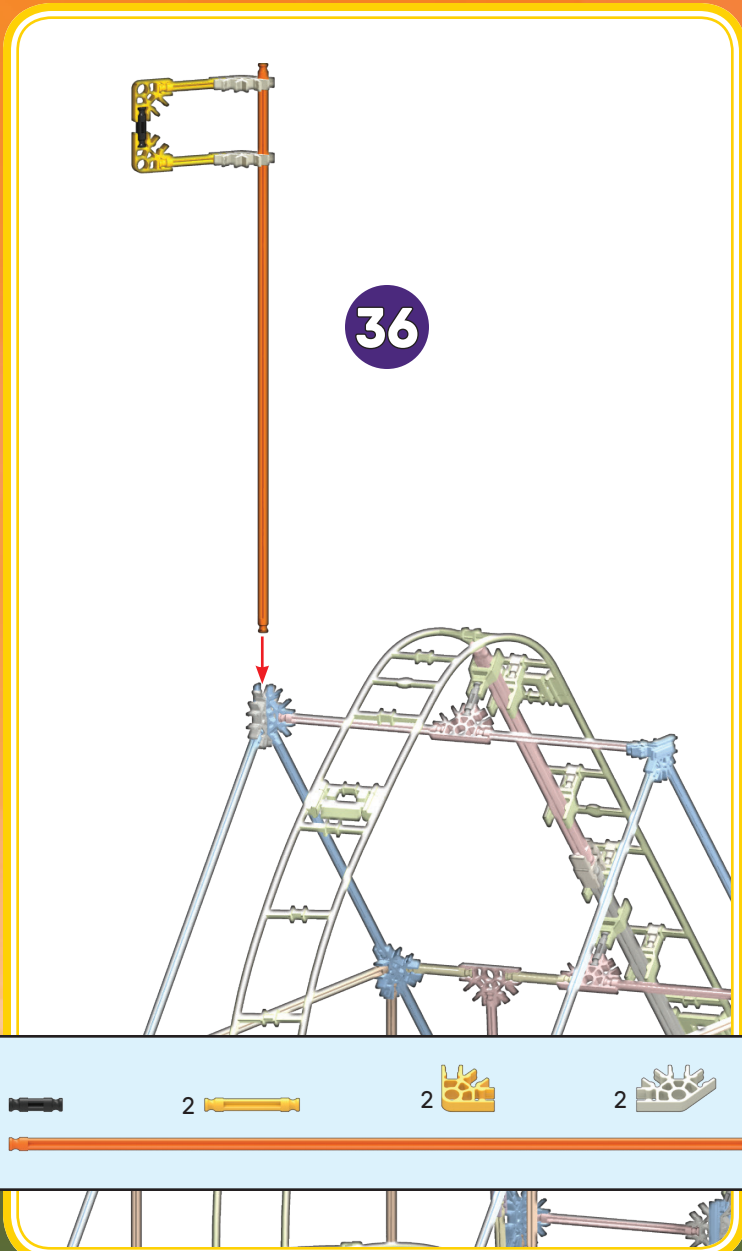

**DINOSAUR DROP  
CHUTE DE DINOSAURE**

## (ES) Español

(Página 2)

### Guarde esta información importante para futuras referencias



**ADVERTENCIA:** PELIGRO DE ASFIXIA – Piezas pequeñas. No para niños menores de 3 años.

**PRECAUCIÓN:** Mantén el cabello, los dedos, la cara y la ropa alejada de las piezas móviles.

**PRECAUCIÓN:** Tenga cuidado de no inclinar el modelo. El modelo debe colocarse sobre una superficie plana y dura.

No obstruyas la pista con objetos o cualquier parte de tu cuerpo.

#### Empieza a construir

Cada pieza tiene su propia forma y color. Simplemente mira los dibujos, busca las piezas correspondientes en tu juego y después conéctalas. Mientras construyes, trata de colocar tu modelo en la misma dirección que se muestra en las instrucciones. Los colores desteñidos muestran que esta sección ya está construida. Conecta las nuevas secciones en los lugares señalados por las flechas. Las nuevas piezas que agregues estarán en colores vivos.

#### Conectores

Usted puede deslizar estos conectores especiales juntos. Empuje firmemente hasta que oiga un "clic".

#### Espaciadores

Asegúrese de usar el color correcto y el número de espaciadores que se muestra en las instrucciones.

(Página 3)

#### Lista de Piezas

Antes de empezar con la construcción, asegúrate de comparar las piezas en tu conjunto con la lista de las piezas aquí. Si faltan algunas, llámanos o escríbenos siguiendo las instrucciones en la página trasera. Estamos aquí para ayudarte.

(Página 4)

**CONSEJOS:** Mientras construyes, trata de colocar tu modelo en la misma dirección que se muestra en las instrucciones.

(Página 14)

Empuja los conectores hacia adentro hasta que oigas un "clic".

(Página 15)

Siempre unirse a este extremo de la pista a la pieza primera pista anterior, a continuación, conecte el resto de la pista a la torre.

## (DE) Deutsch

(Seite 2)

### Informationen für später aufbewahren



**ACHTUNG:** ERSTICKUNGSGEFahr – Kleinteile. Nicht geeignet für Kinder unter 3 Jahren.

**VORSICHT:** Haare, Finger, Gesicht und Kleidungsstücke nicht mit beweglichen Teilen in Berührung kommen lassen.

**VORSICHT:** Sei vorsichtig, das Modell nicht um zuschmeissen. Das Modell sollte auf eine flache und harte Oberfläche gestellt werden.

Die Schienen dürfen nicht blockiert oder mit dem Körper verdeckt werden.

#### Los geht's mit dem Bauen

Jedes Teil hat seine eigene Form und Farbe. Schau dir einfach die Abbildungen an, such die Teile in deinem Bausatz, die so aussehen wie das, was du auf der Abbildung siehst und steck sie ineinander. Versuche, dein Modell beim Zusammenbauen so zu orientieren, dass es in die gleiche Richtung weist, wie es in den Anleitungen beschrieben und gezeigt wird. Blasser Farben weisen darauf hin, dass dieser Streckenabschnitt bereits zusammenggebaut ist.

#### Verbindungsstücke

Verbindungsstücke haben besonders lange Schlitz. Achte beim Aneinanderfügen dieser Teile darauf, dass du ein Klickgeräusch hörst. Wie du auf der Abbildung sehen kannst, lassen sie sich ineinander schieben. Achte beim Aneinanderfügen dieser Teile darauf, dass du ein Klickgeräusch hörst. Erst dann sind die Teile fest miteinander verbunden.

#### Abstandsstücke

An manchen Stellen in deinem Modell musst du Abstandsstücke einbauen. Achte darauf, die richtige Anzahl von Abstandsstücken wie in der Anleitung gezeigt zu verwenden.

(Seite 3)

#### Teilleiste

Bevor du mit dem Bauen anfängst, solltest du prüfen ob die Teile in deinem Bausatz mit denen auf dieser Teilleiste übereinstimmen.

Falls etwas fehlt, rufe uns an oder schreibe uns (siehe Rückseite). Wir sind für dich da!

(Seite 4)

**TIPP:** Versuche, dein Modell beim Zusammenbauen so zu orientieren, dass es in die gleiche Richtung weist, wie es in den Anleitungen beschrieben und gezeigt wird.

(Seite 14)

Druk de koppelstukken goed erin tot ze "klikken".

(Seite 15)

Immer beitreten dieses Ende der Strecke zum vorherigen Track Stück zuerst, dann treten der Rest der Strecke auf den Turm.

## (IT) Italiano

(Pagina 2)

### Conservare queste importanti informazioni per riferimento futuro



**AVVISO:** PERICOLO DI SOFFOCARE – Pezzi piccoli. Non adatto per bambini sotto 3 anni.

**ATTENZIONE:** Tenere i capelli, le dita, il viso e i vestiti lontano da tutte le parti in movimento.

**ATTENZIONE:** Fare attenzione a non inclinare il modello sopra. Modello deve essere collocato su una superficie piana e dura.

Non ostruire la pista con gli oggetti o qualsiasi parte del vostro corpo.

#### Comincia a costruire

Ogni pezzo ha una sua forma e un suo colore. Guarda la figura, trova i pezzi corrispondenti nel set e mettili insieme. Cerca di tenere il modello nella stessa direzione della figura e in tal modo sarà più semplice attaccare i pezzi nei posti giusti. I colori spenti ti dicono che questa sezione è già stata costruita. Dovrai collegare la nuova sezione al punto indicato dalla punta della freccia.

#### Connettori

È molto importante posizionare i connettori in una specifica direzione. Presta molta attenzione alle istruzioni e posiziona i connettori orizzontalmente o verticalmente proprio come illustrato. Spingi con forza fino ad udire un clic.

#### Spaziatori

Ci sono punti nel tuo modello a cui dovrai aggiungere spaziatori. Accertati di contarli attentamente.

(Pagina 3)

#### Elenco delle parti

Prima di cominciare a costruire, accertati di confrontare le parti che sono nel tuo set con l'elenco delle parti qui. Se ne manca una chiamaci o scrivici usando le informazioni che sono nella retrocopertina. Noi siamo qui per aiutarvi!

(Pagina 4)

**SUGGERIMENTI:** Orienta il tuo modello nella stessa direzione indicata nelle istruzioni.

(Pagina 14)

Premi i connettori saldamente fino a che si fissano con uno scatto.

(Pagina 15)

Sempre partecipare a questo fine della traccia per traccia del pezzo precedente, poi collegare il resto della pista alla torre.

## (PT) Português

(Página 2)

### Manter esta informação importante para referência futura



**AVISO:** PERIGO DE SUFOCAÇÃO – Peças pequenas. Não se destina a crianças com menos de 3 anos de idade.

**CUIDADO:** Mantém o cabelo, os dedos, a cara e a roupa afastados de todas as peças móveis.

**CUIDADO:** Tenha cuidado para não derrubar o modelo. O modelo deve ser colocado sobre uma superfície plana e dura.

Não obstruir a trilha com objetos ou qualquer parte de seu corpo.

#### Inicia a construção

Cada peça tem a sua própria forma definida e cor. Basta simplesmente olhares para a ilustração, procurar as peças do teu jogo correspondentes às que estás a ver e, em seguida, conectar umas nas outras. Enquanto estás a montar as peças, tenta manter o teu modelo na mesma direção, conforme mostrado na ilustração, para assim ligares as peças correctamente. As cores desbotadas

indicam que esta secção já está montada. Passarás então a fazer a conexão da nova secção no local indicado pelas setas.

#### Conectores

Empurre estes conectores especiais juntos firmemente até ouvir um "clique". Presta muita atenção às instruções e coloca estes conectores horizontal ou verticalmente, exactamente conforme se mostra nas ilustrações. Junta as partes simultaneamente e com firmeza até ouvires um "estalido".

#### Espaçadores

Existirão certos pontos no teu modelo que necessitam a colocação de espaçadores. Assegura-te que os contagem cuidadosamente.

(Página 3)

#### Lista de peças

Antes de iniciaras a construção, certifica-te de que comparas as peças do teu conjunto com a lista das peças aqui. Se faltar alguma peça telefona ou escreve-nos usando as informações indicadas na contracapa. Estamos aqui para te ajudar!

(Página 4)

**SUGESTÕES:** Tenta fazer com que o teu modelo esteja virado exactamente na mesma direção indicada nas instruções.

(Página 14)

Faz avançar os conectores firmemente até "encaixarem" com um estalido.

(Página 15)

Sempre aderir a este final da trilha para a peça faixa anterior primeiro, e depois conectar o restante da trilha para a torre.

## (NL) Nederlands

(Bladzijde 2)

### Bewaar deze belangrijke informatie, zodat u deze in de toekomst opnieuw kunt raadplegen



**WAARSCHUWING:** INSLIKKINGSGEVAAR – Kleine onderdelen. Niet geschikt voor kinderen jonger dan 3 jaar.

**OPGEPAST:** Houd handen, haar, gezicht en kleding uit de buurt van bewegende onderdelen.

**OPGEPAST:** Zorg ervoor dat het model niet te kantelen. Model moet op een vlak en hard oppervlak geplaatst.

Het spoor niet versperren met objecten of met een deel van je lichaam.

#### Begin te bouwen

Elk stuk heeft zijn eigen vorm en kleur. Kijk gewoonweg naar de afbeeldingen, vind de overeenstemmende stukken terug in je geheel en maak ze aan mekaar vast. Tracht je model in dezelfde richting te plaatsen als de aanwijzingen terwijl je bouwt en monteert. De vervaagde kleuren duiden aan dat dit deel reeds is opgebouwd. Gelieve het nieuwe deel vast te koppelen op de plaats aangeduid door de pijlen.

#### Verbindingsstukken

Duw deze speciale verbindingstukken stevig tegen elkaar aan tot je een 'klik' hoort. Let goed op de instructies en plaats ze horizontaal en verticaal, precies zoals wordt getoond.

#### Afstandhouders

Op bepaalde plekken van je model moet je afstandhouders gebruiken. Zorg dat je het juiste aantal afstandhouders gebruikt, zoals wordt getoond in de instructies.

(Bladzijde 3)

#### Lijst met onderdelen

Controleer aan de hand van deze lijst of je set alle onderdelen bevat voordat je begint te bouwen. Als er een onderdeel ontbreekt, bel of schrijf ons dan. Je vindt onze gegevens op de achterkant. We helpen je graag!

(Bladzijde 4)

**TIP:** Tracht je model in dezelfde richting te plaatsen als de aanwijzingen terwijl je bouwt en monteert.

(Bladzijde 14)

Druk de koppelstukken goed erin tot ze "klikken".

(Bladzijde 15)

Altijd deelnemen aan deze eind van het spoor naar de vorige track stuk eerst, dan komen de rest van de track naar de toren.

**k'nex**  
where creativity clicks®

**DINOSAUR DROP**  
Roller Coaster Building Set  
**CHUTE DE DINOSAURE**  
Montagnes Russes Jeu de construction

**knex.com**

@knex

facebook.com/knex

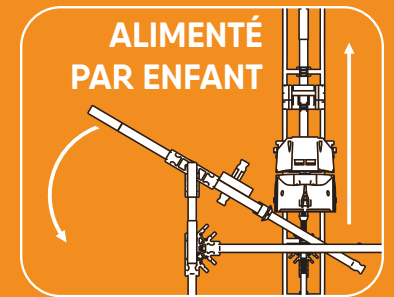

**T-REX FURY**  
Roller Coaster Building Set  
**FUREUR DU T-REX**  
Montagnes Russes Jeu de Construction

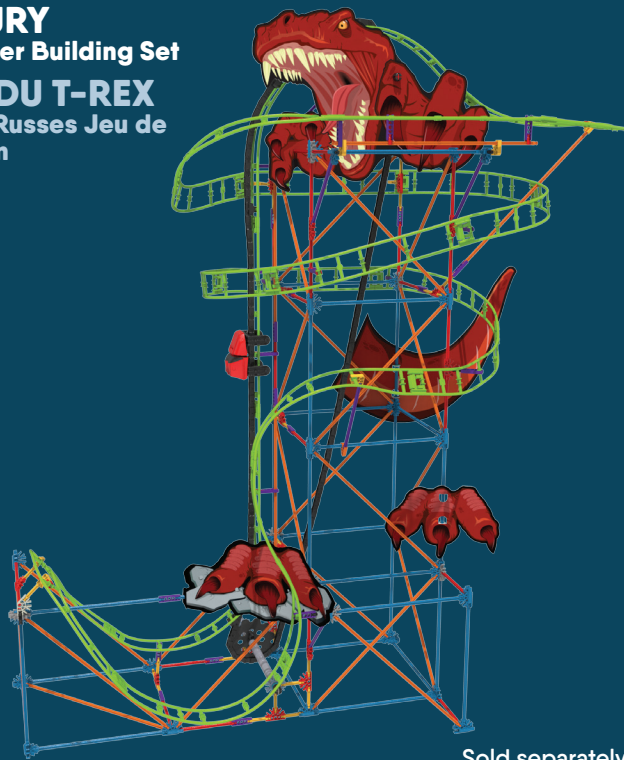

Sold separately  
Vendus séparément

**RIPPING RAPTOR**  
Building Set  
**RAPTOR DÉCHIRANT**  
Jeu de Construction



Sold separately  
Vendus séparément

**k'nex RIDE IT!** **k'nex 3D** Download Our Apps  
Téléchargez notre applications

(EN) Product & colors may vary. Most models can be built one at a time.  
(FR) Le produit et ses couleurs peuvent varier. Les différents modèles ne peuvent être construits qu'un par un.  
(ES) El producto y los colores pueden variar. La mayoría de los modelos se pueden construir uno a la vez.  
(DE) Produkte und Farben können abweichen. Die meisten Modelle können immer nur einzeln gebaut werden.  
(IT) Prodotti e colori possono differire. La maggior parte dei modelli si può costruire autonomamente. Istruzioni accluse.  
(PT) O produto e as cores podem variar. A maioria dos modelos pode ser montado um de cada vez.  
(NL) Product en kleuren kunnen variëren. De meeste modellen kunnen uitsluitend een voor een worden gebouwd.

**k'nex**  
RIDE IT!

**CONSTRUIRE ET  
ROULER APPLICATION**

©2018 K'NEX, a Division of Basic Fun, Inc., P.O. Box 700, Hatfield, PA 19440-0700; 1-800-KID-KNEX (USA/Canada/États-Unis/EE.UU.); email@knex.com; knex.com. K'NEX UK Ltd, 200 Brook Drive, Green Park, Reading, RG6 2UB England; K'NEX France, 24 rue du Quatre Septembre, 75002 Paris, France. For customers outside the USA/Canada please contact your local distributor at [www.knex.com/distributors](http://www.knex.com/distributors).

(FR) Pour les clients en dehors du Canada et des États-Unis, veuillez contacter votre distributeur local que vous pouvez trouver sur [www.knex.com/distributors](http://www.knex.com/distributors).

(ES) El cliente que no vive en EE.UU./Canadá se pone en contacto con el distribuidor local. Encuentre la información para el distribuidor local en [www.knex.com/distributors](http://www.knex.com/distributors).

(EN) K'NEX and Where Creativity Clicks are registered trademarks and Thrill Rides is a trademark of Basic Fun, Inc.

(FR) K'NEX et Where Creativity Clicks sont des marques déposées et Thrill Rides est une marque de commerce de Basic Fun, Inc.

128041-V1-3/18