

# K'NEX®

# CORKSCREW CANYON™

**TUBE PARK**  
**PARC AQUATIQUE À CHUTES**



**⚠️ AVERTISSEMENT:**  
**DANGER D'ÉTOUFFEMENT** – Pièces de petite taille.  
Ne pas donner aux enfants de moins de 3 ans.

**⚠️ WARNING:**  
**CHOKING HAZARD** – Small Parts.  
Not for children under 3 years.

**9+**

**Building System**  
**Système De Construction**

# CORKSCREW CANYON™

**TUBE PARK**  
**PARC AQUATIQUE À CHUTES**

## WHAT'S INSIDE?

Important Stuff for Parents & Kids	2
Battery Information	3
K'NEX Building Basics	4
Parts Count	5
Corkscrew Canyon	6
Alternate Build	50
Tips & Troubleshooting	89
French	90
Spanish	91
German	92
Dutch	93
Italian	94
Portuguese	95



Build a **gigantic thrill** park with **3 awesome slides** and a wild, **spiraling funnel!** Then, turn on the motorized chain lift and the **tubers scream and laugh** as they **race to the bottom!**

## IMPORTANT STUFF FOR PARENTS & KIDS

Keep these instructions in a handy location. They contain important safety information.

Read all warnings and instructions before you start to build and operate the model.

**WARNING:** CHOKING HAZARD - Small parts. Not for Children under 3 years.

**CAUTION:** Keep hands, face, hair and clothing away from all moving parts.

**CAUTION:** Do not use Sound Module close to ear! Misuse may cause damage to hearing.

- Share the K'NEX® experience with your child and make building with K'NEX a family fun adventure.
- Build on a flat level surface.
- You will need floor space to build your model. The Corkscrew Canyon is 41" x 33" (1m x .8m). The Alternate Build is 46" x 55" (1.1m x 1.3m).
- If you need to move your model after it's built, you can lift it carefully, making sure you are not unsnapping the connections.
- Product and colors may vary. Builds one model at a time

## MOTOR & BATTERY INFORMATION

### CAUTION:

- Make sure batteries are inserted correctly and follow the toy and battery manufacturer's instructions.
- Insert batteries with correct polarity (+/-) as shown.
- Do not mix different types of batteries; do not mix alkaline, standard (carbon-zinc), or rechargeable (nickel-cadmium) batteries. Do not mix new and used batteries. Only batteries of the same or equivalent type recommended should be used.
- Remove exhausted batteries from the toy; do not short circuit supply terminals.
- Remove all batteries if the toy is not used for a long period of time.
- Do not dispose of batteries in a fire; they could leak or explode and cause injury.

### IMPORTANT TIPS:

- Alkaline batteries are recommended.
- Rechargeable batteries are not recommended.
- Remove rechargeable batteries before recharging; they must be charged only under adult supervision.
- Non-rechargeable batteries must not be recharged.
- Keep components free of dust; do not immerse in water.

### Test the Motor first:

Before you start building, insert 3 fresh "C" batteries (LR14) into the compartment with the correct polarity.

### How to Insert and Remove Batteries:

Use a small Philips Head screwdriver to loosen the screw, then remove the battery door. Insert 3 fresh "C" batteries (LR14) into the compartment with the correct polarity (+/-) as shown here.

### Sound doesn't work?

Check to see if you have fresh batteries and that they are installed properly.

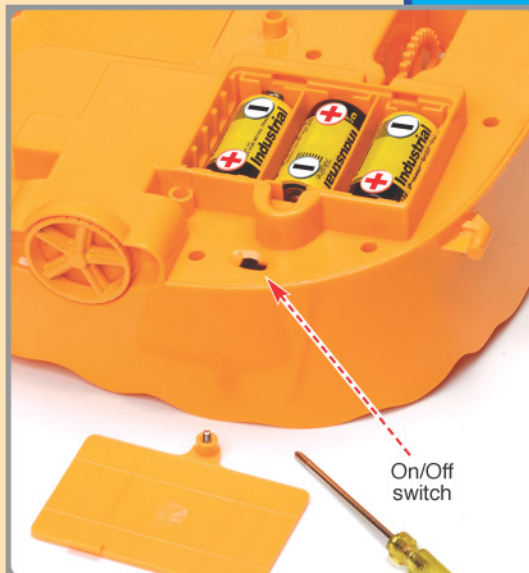

### Automatic or Manual Ramp Selection:

1. Ramp selector wheel must be fully pushed in for the Motor to automatically select paths.
2. To manually select a path yourself, pull the Ramp selector wheel out and turn it to a desired path.

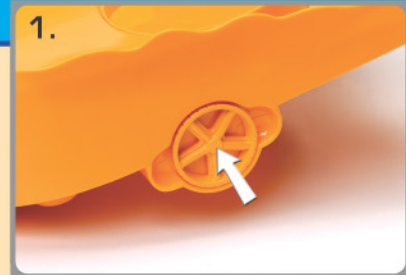

### Bottom view of Motor:

These 5 holes are where the K'NEX Rods attach.

### FCC Statements:

This device complies with Part 15 of the FCC Rules. Operation is subject to the following two conditions:

1. This device may not cause harmful interference and
2. This device must accept any interference received, including interference that may cause undesired operation. This model is tested to comply with FCC standards - FOR HOME OR OFFICE USE.

This equipment has been tested and found to comply with the limits for a Class B digital device, pursuant to part 15 of the FCC Rules. These limits are designed to provide reasonable protection against harmful interference in a residential installation. This equipment generates, uses and can radiate radio frequency energy, and, if not installed and used in accordance with the instructions, may cause harmful interference to radio communications. However, there is no guarantee that interference will not occur in a particular installation. If this equipment does cause harmful interference to radio or television reception, which can be determined by turning the equipment off and on, the user is encouraged to try to correct the interference by one or more of the following measures: (1) Reorient or relocate the receiving antenna. (2) Increase the separation between the equipment and receiver. (3) Consult the dealer or an experienced radio/TV technician.

This Class B digital apparatus complies with Canadian ICES-003.

# K'NEX BUILDING BASICS

## 1. Building with K'NEX



"Hi! I'm your K'NEX Building Buddy. When you see me in the instructions, you'll want to pay close attention to the details being pointed out."

## 2. Ready, Set, Build

To begin your model, find the  and follow the numbers. Each piece has its own shape and color. Just look at the pictures, find the pieces in your set that match and then connect them together.

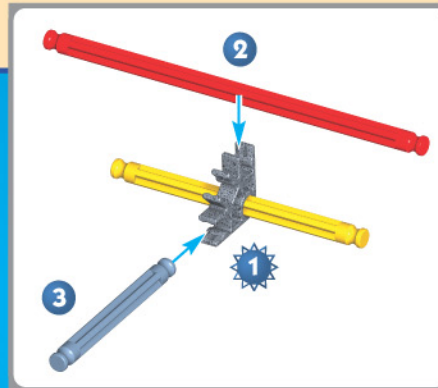

## 3. Movin' On

Faded colors show you this section is already built. You'll want to connect the new section to the place where the arrows are pointing. The new pieces you add and the place where they connect will be in full color.

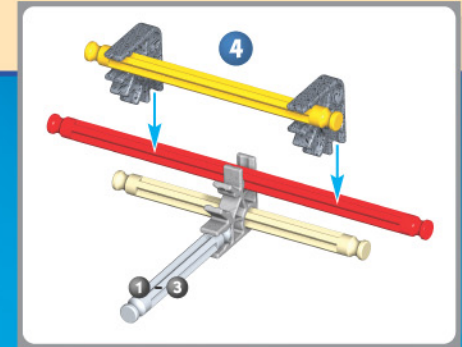

## 4. Connectors

There are blue and silver Connectors with special long slots. They slide together as you see in the pictures. Push these parts together until you hear a "click".

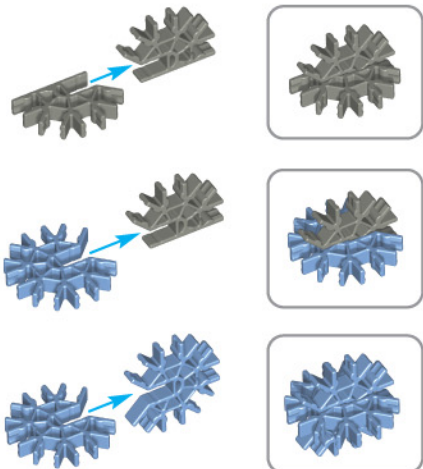

## 5. Spacers

There are places in your model where you need to add blue and silver Spacers. Be sure to use the right color and count them carefully.

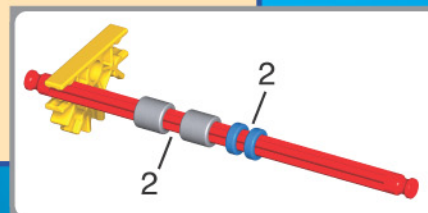

## 6. Chain Links

**IMPORTANT:** Attach the Chain Links in the same direction and snap both sides of each Link.



## Our Warranty (US and Canada)

K'NEX Industries warrants the CORKSCREW CANYON set to be free of manufacturing defects in material and workmanship for a period of 90 days from the date of purchase. If, within the period of warranty, any part proves to have such defect, it will be replaced or repaired at our option at no charge.

K'NEX will not be responsible for damage and/or abuse to your CORKSCREW CANYON set, and such will not be covered by this warranty. Also, K'NEX will not be responsible for damage caused by defective or old batteries. Old or damaged batteries can leak and corrode metals.

K'NEX's sole and exclusive liability for defects in materials and workmanship shall be limited to repair or replacement by our Consumer Services Department, and K'NEX shall not be liable of incidental, consequential, contingent damages, except in those states that do not allow this exclusion or limitation.

This warranty gives you specific legal rights. You may have other rights which vary from state to state.



# CORKSCREW CANYON

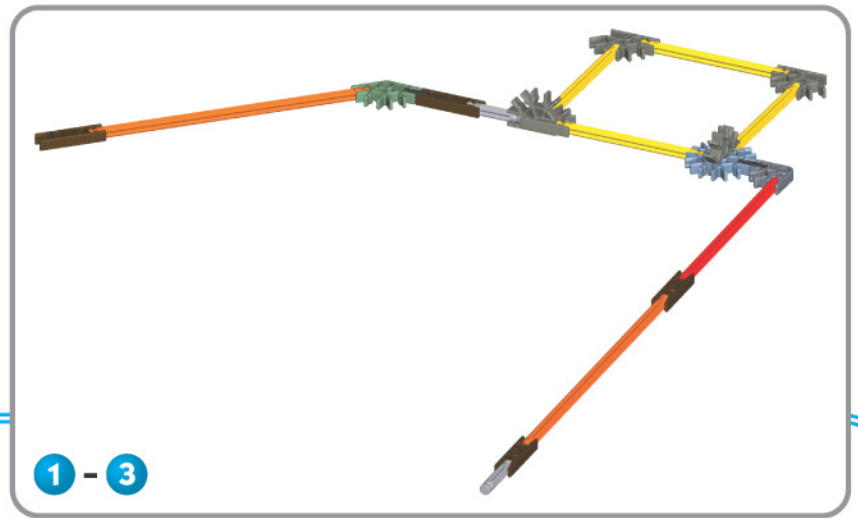

1 - 3

1

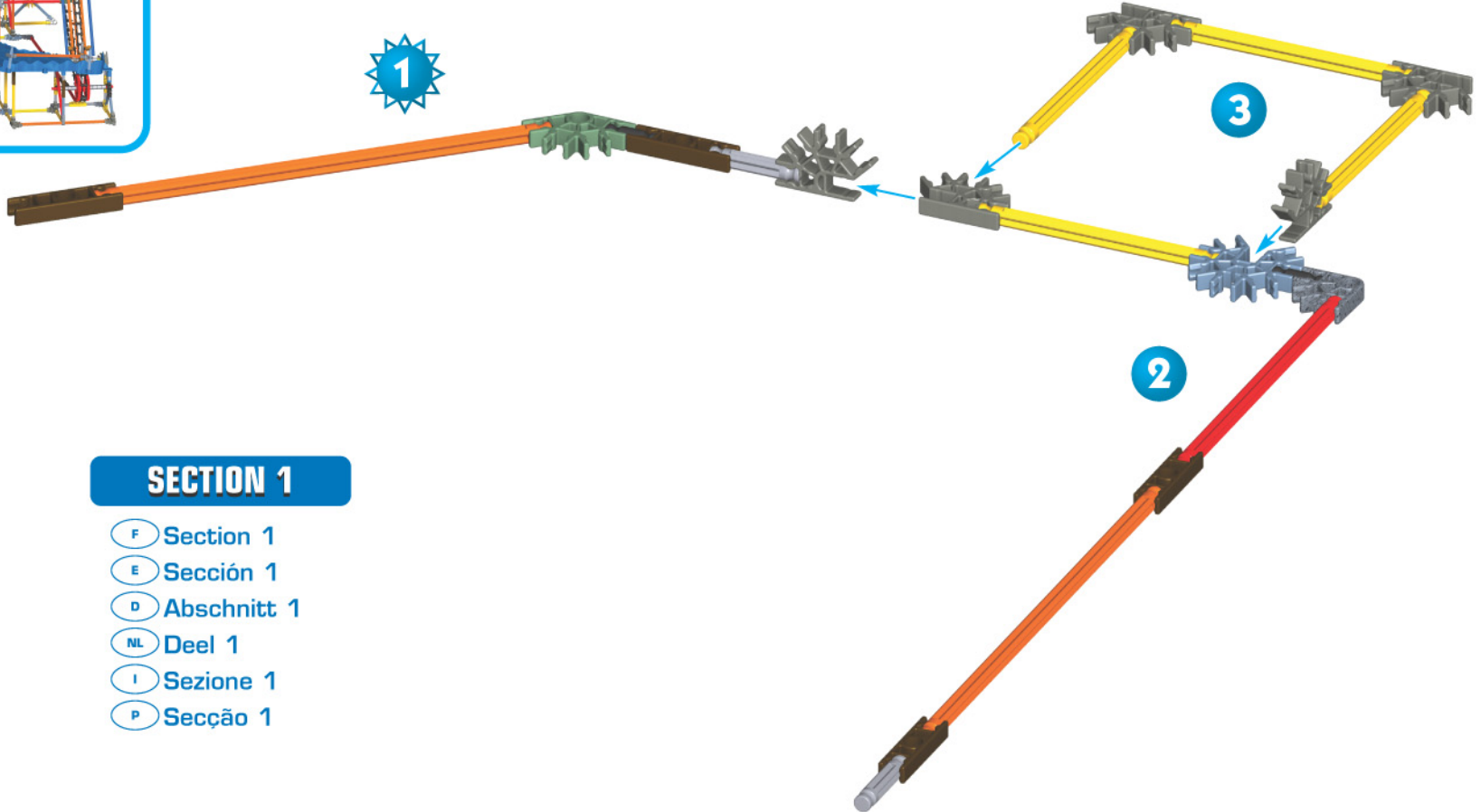

## SECTION 1

- (F) Section 1
- (E) Sección 1
- (D) Abschnitt 1
- (NL) Deel 1
- (I) Sezione 1
- (P) Secção 1

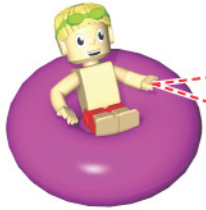

4

5

6

7

**ENG** Be sure to position all Connectors correctly.

**F** Veillez à orienter correctement tous les connecteurs.

**E** Asegúrate de orientar todos los conectores correctamente.

**D** Achte auf die richtige Ausrichtung der Verbindungsstücke.

**NL** Verzekert je ervan alle koppelstukken juist af te richten.

**I** Accertati di orientare tutte le connessioni correttamente.

**P** Certifica-te de que orientas os Conectores correctamente.

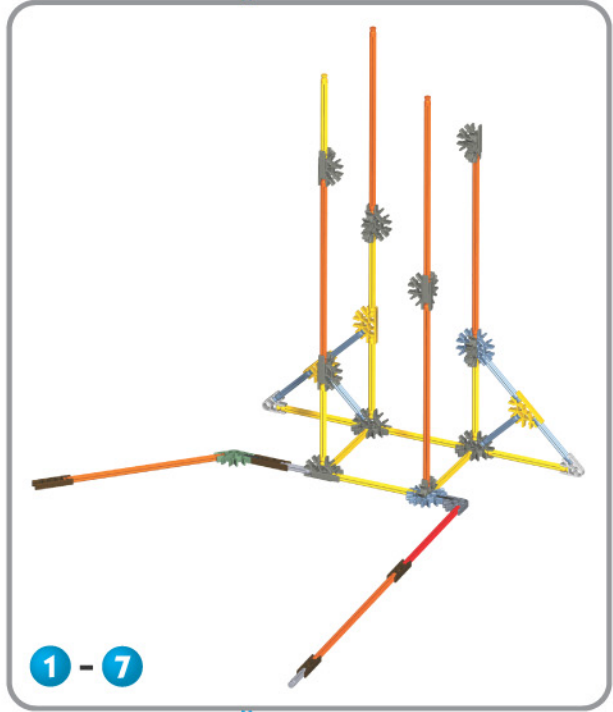
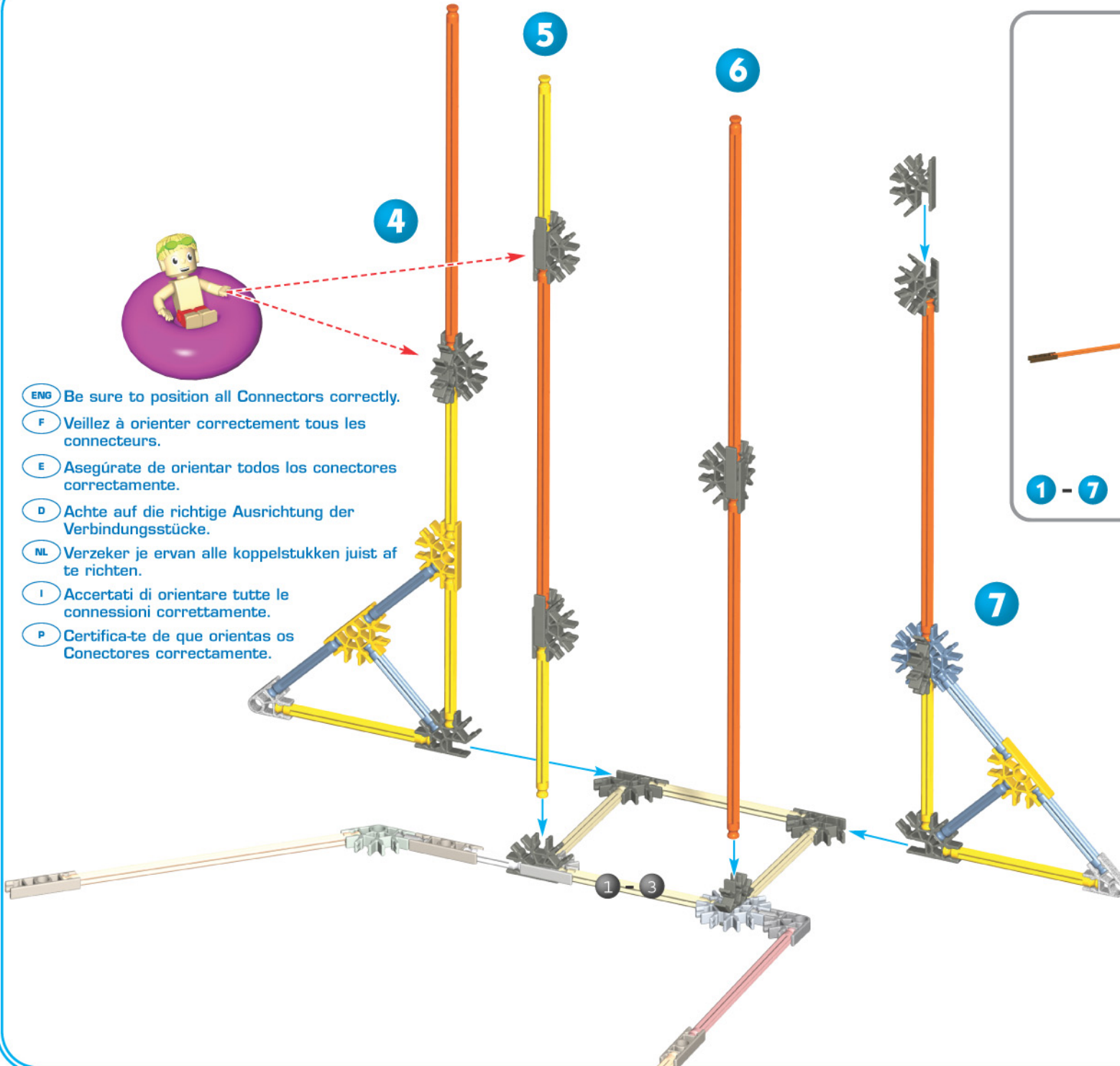

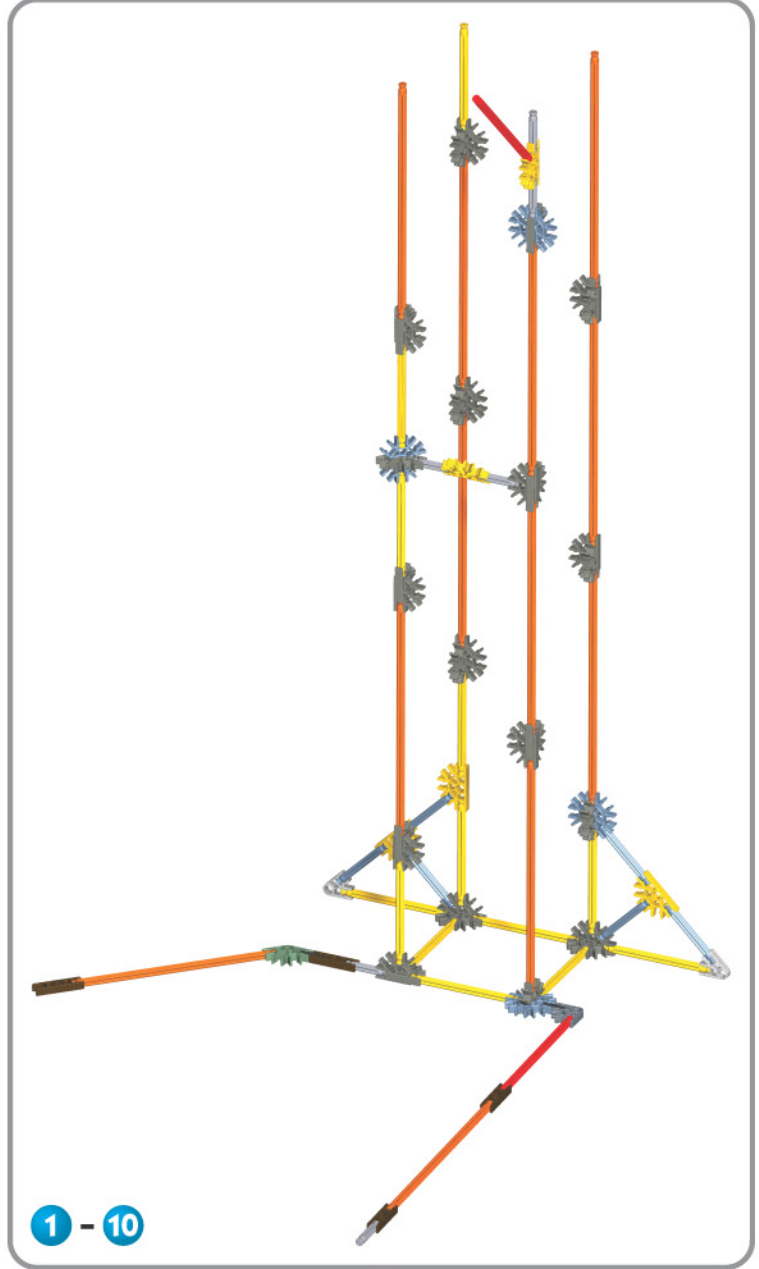
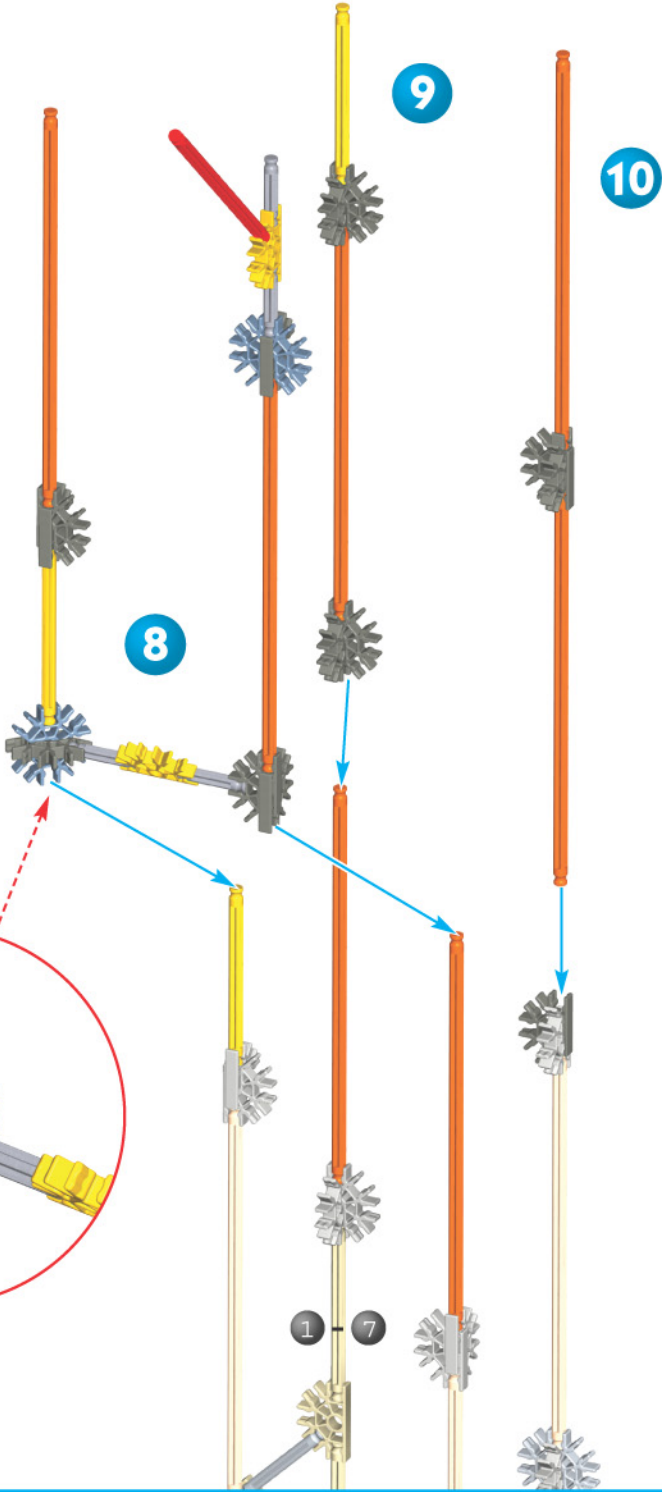
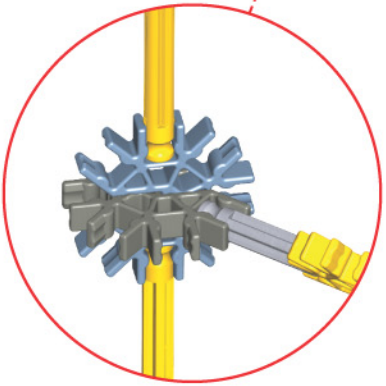

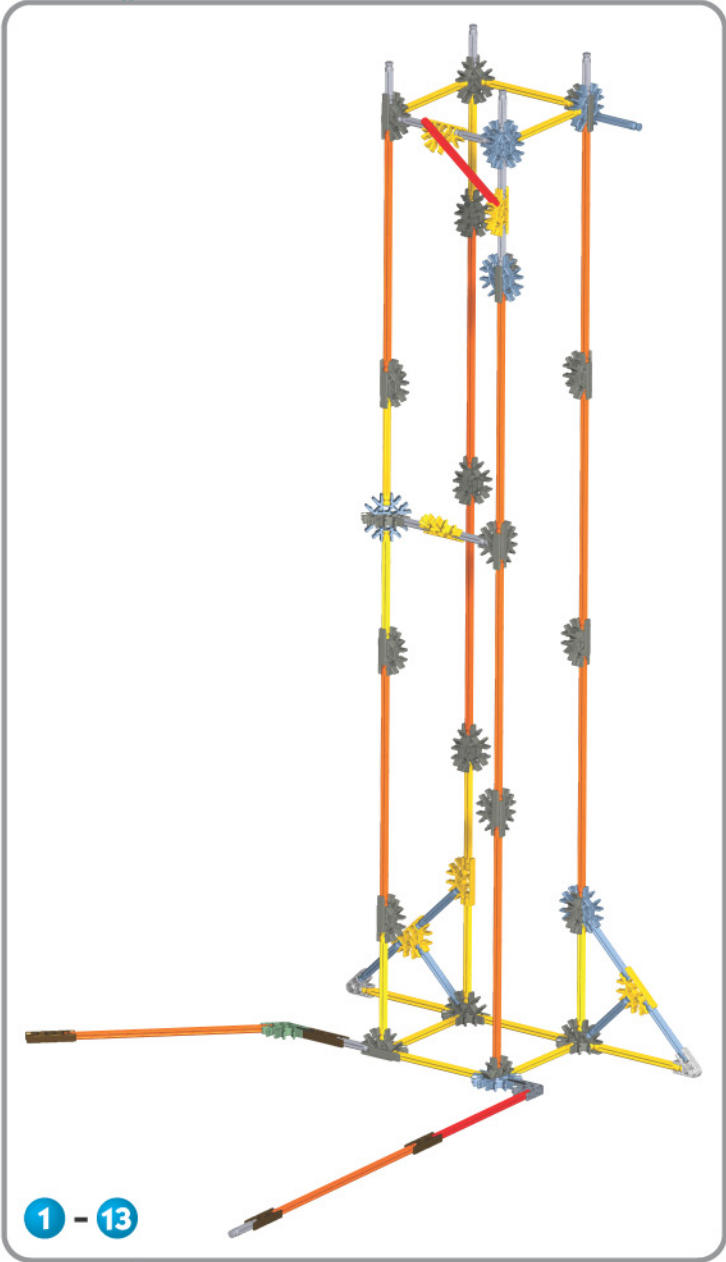
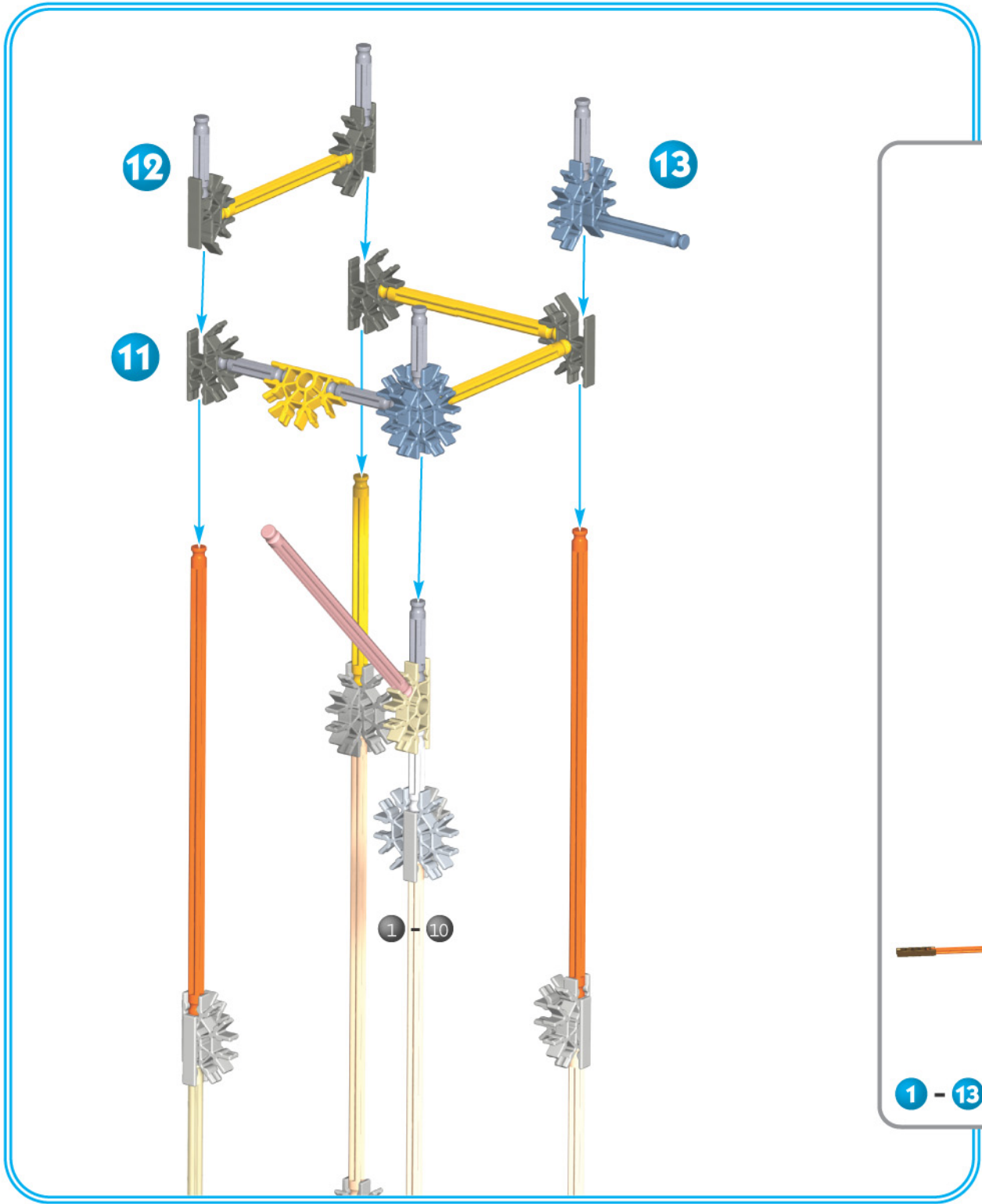

14

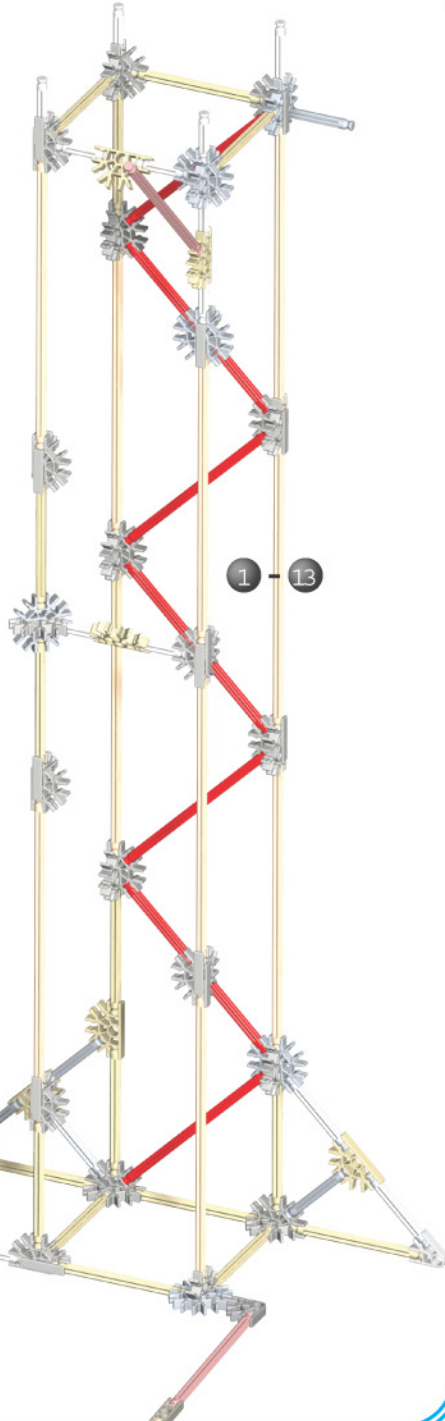
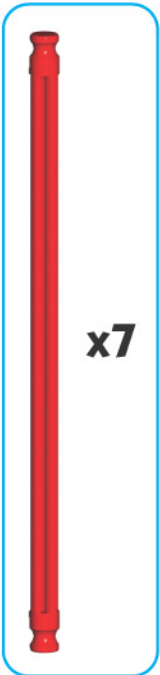

15

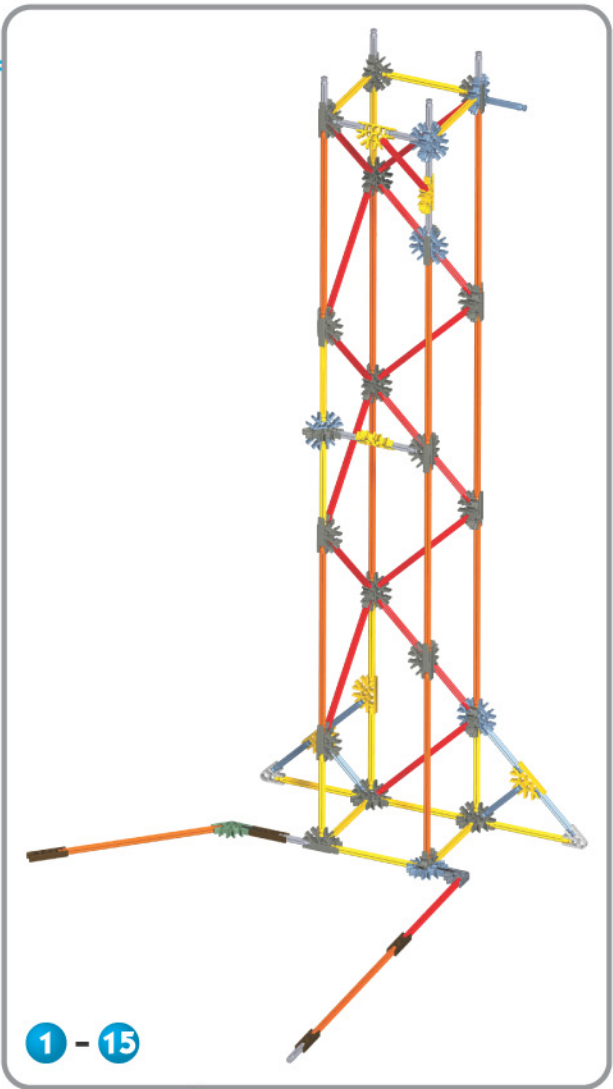
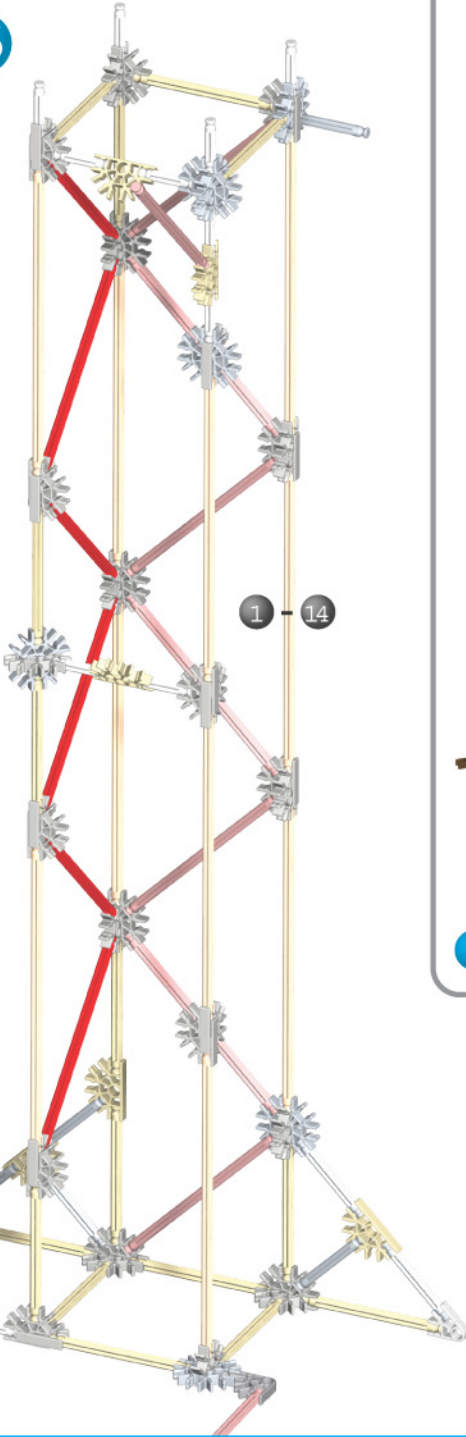
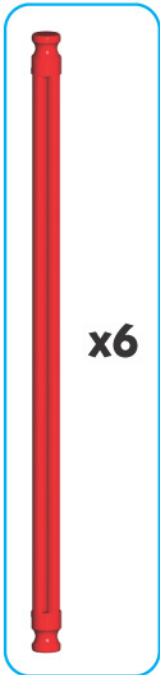

16

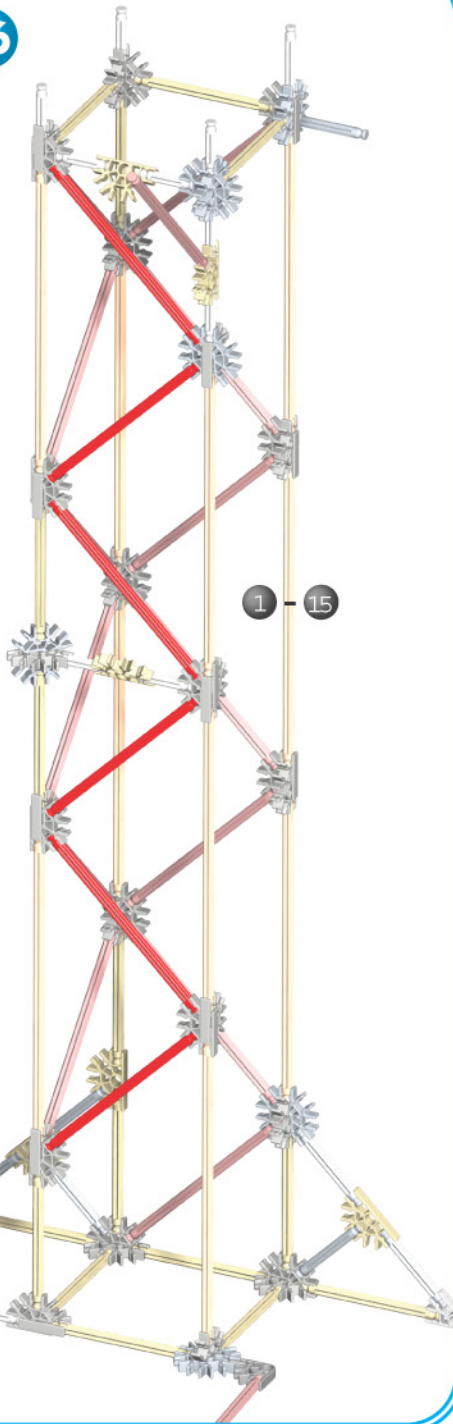
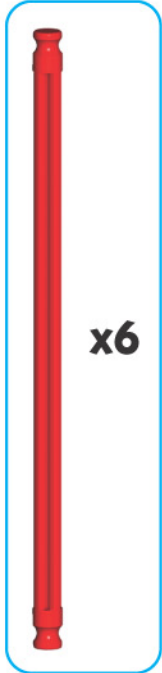

17

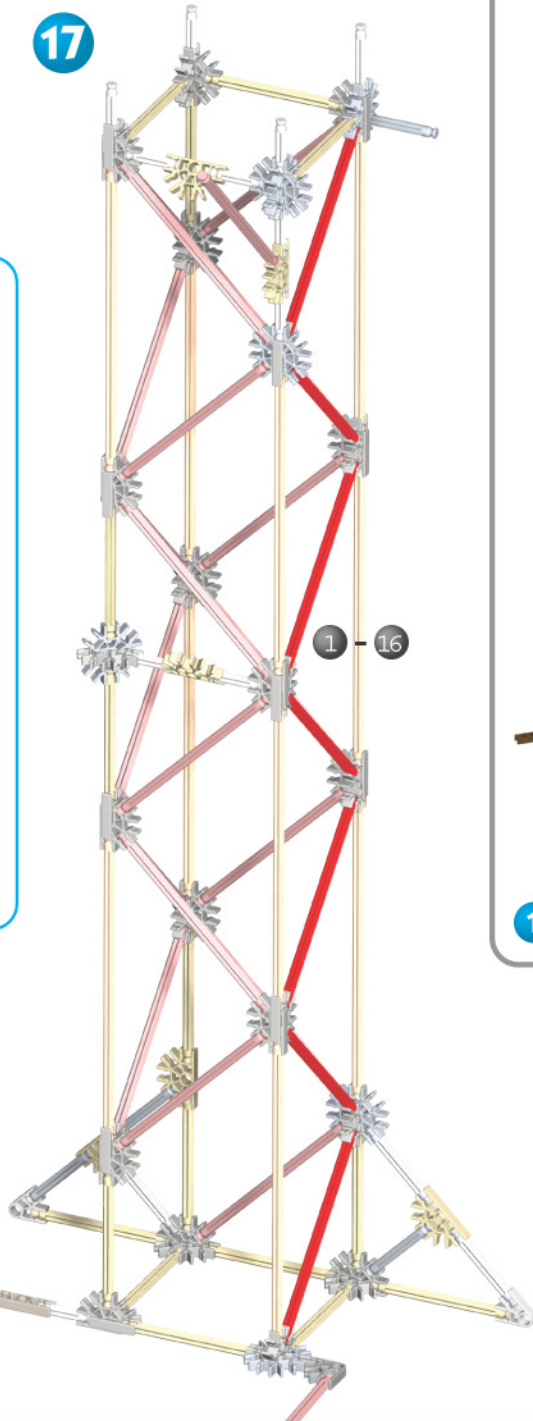
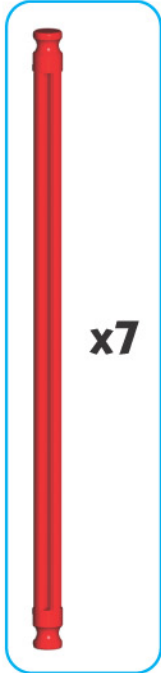

1 - 17

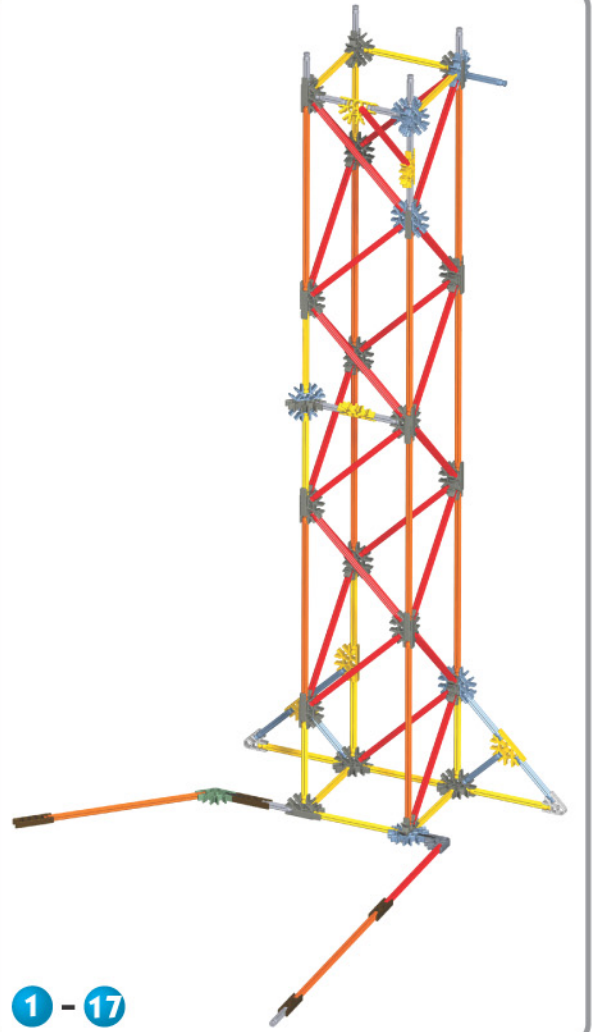

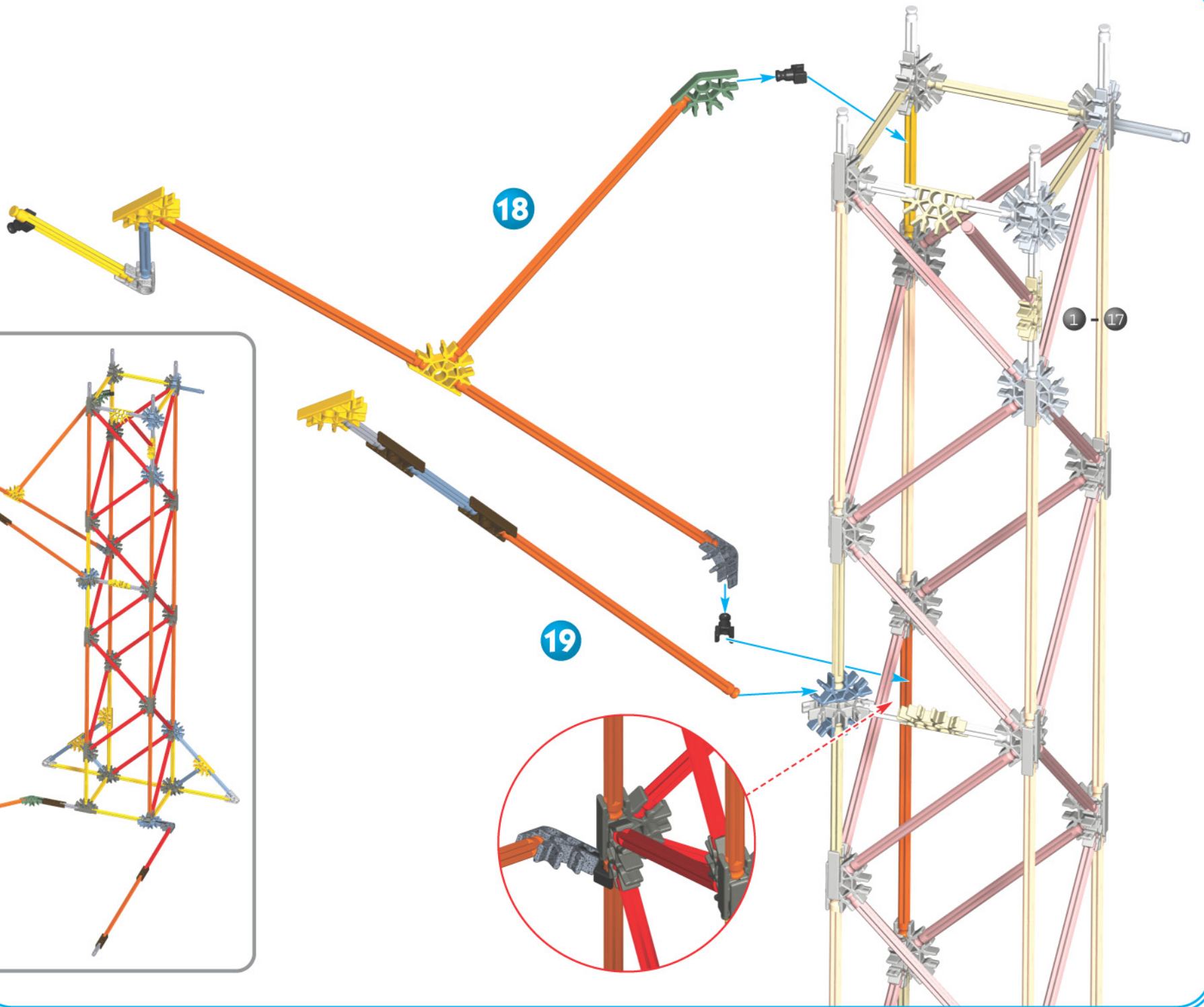
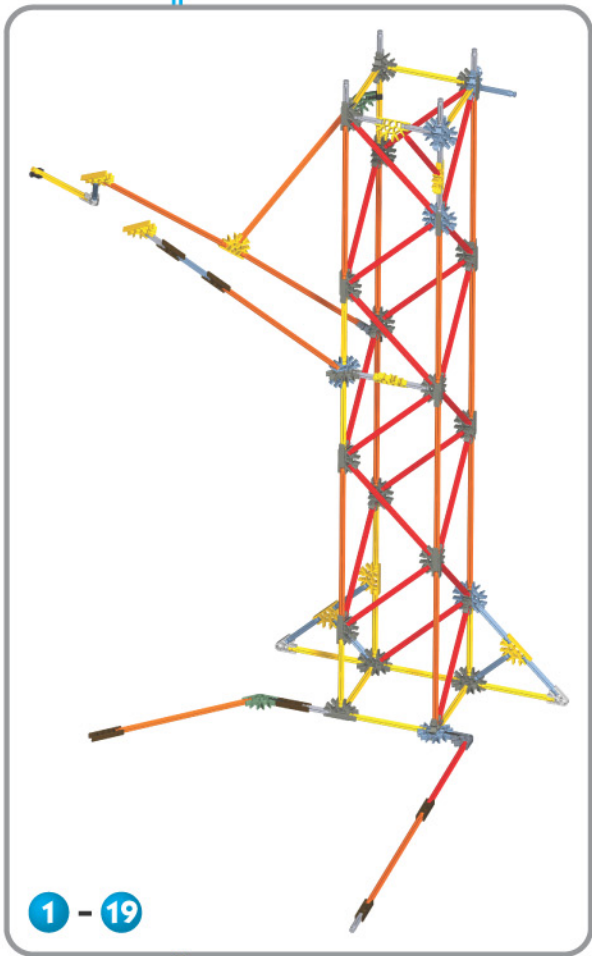

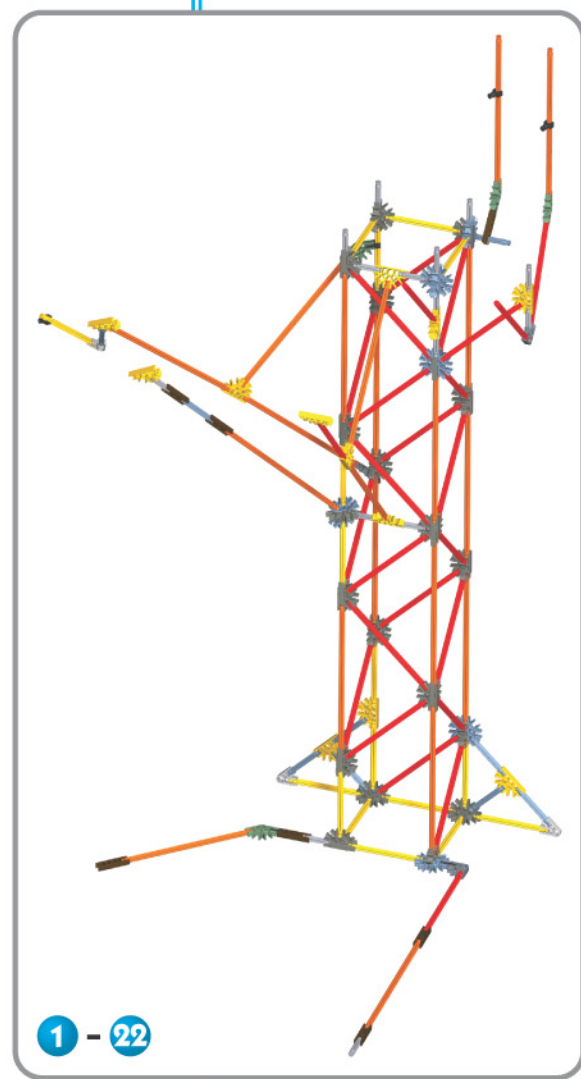
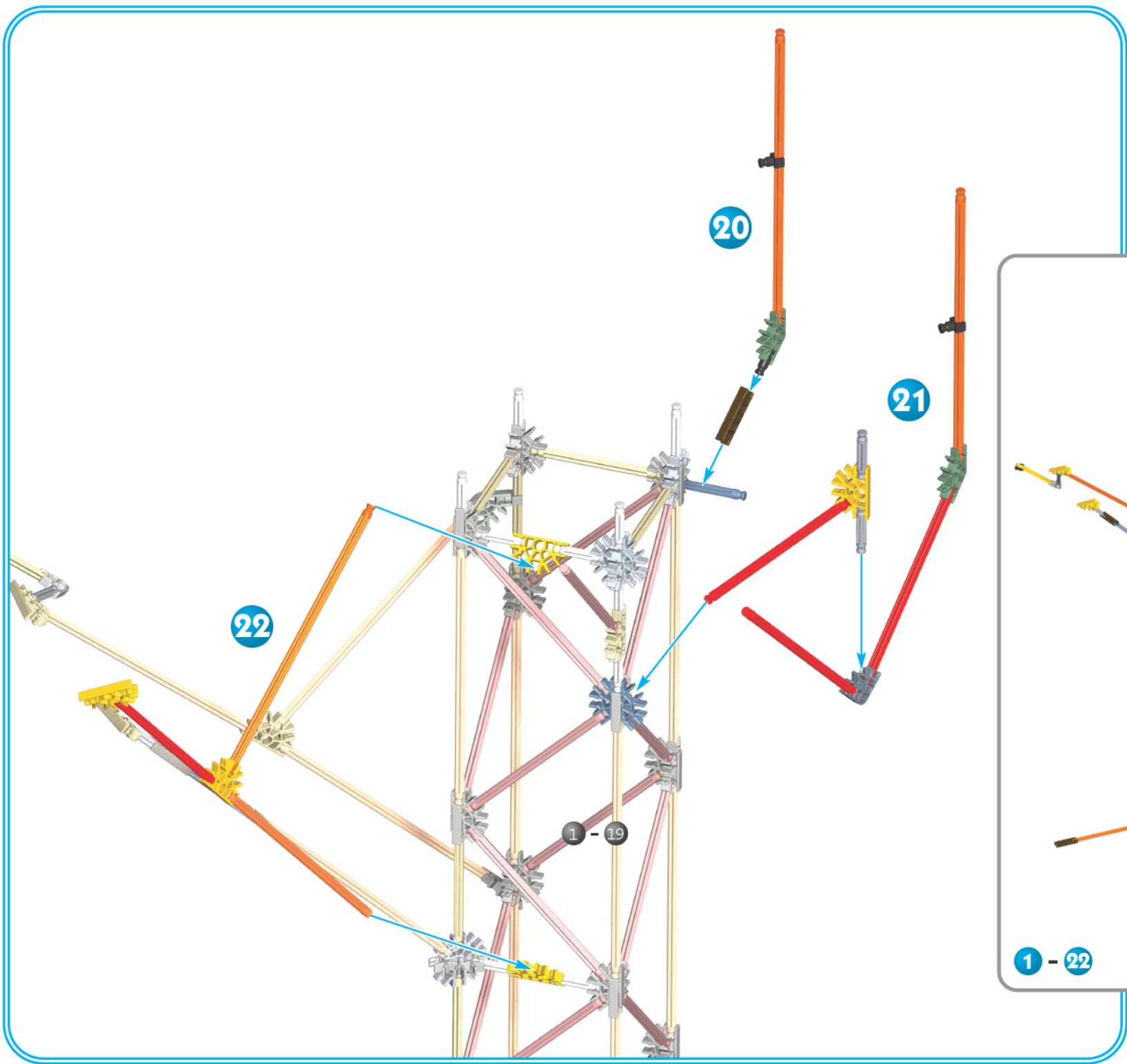

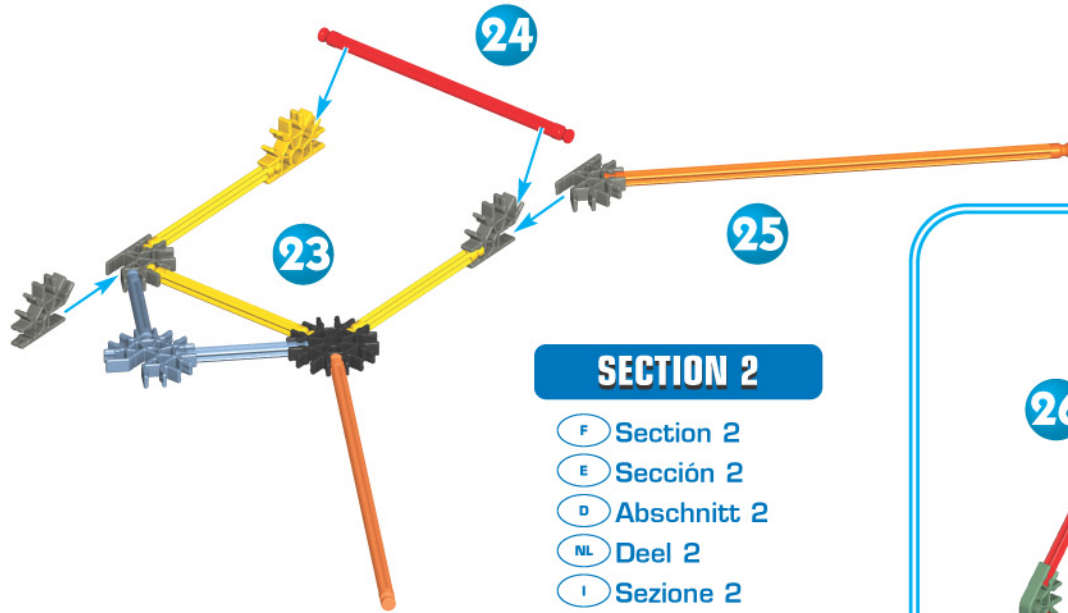

### SECTION 2

- F Section 2
- E Sección 2
- D Abschnitt 2
- NL Deel 2
- I Sezione 2
- P Secção 2

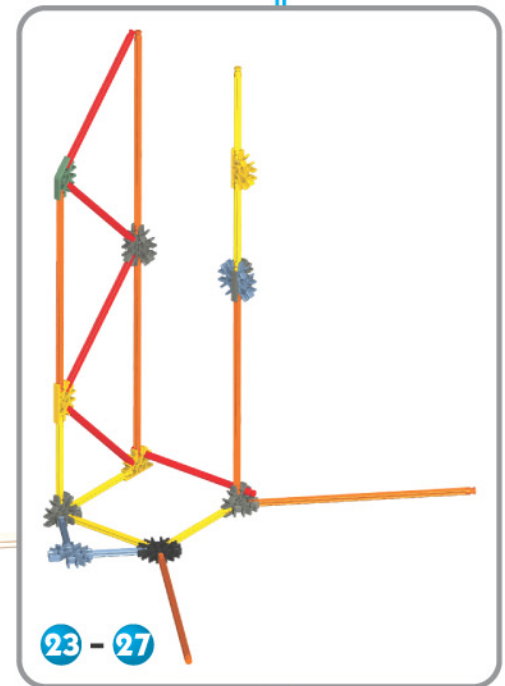
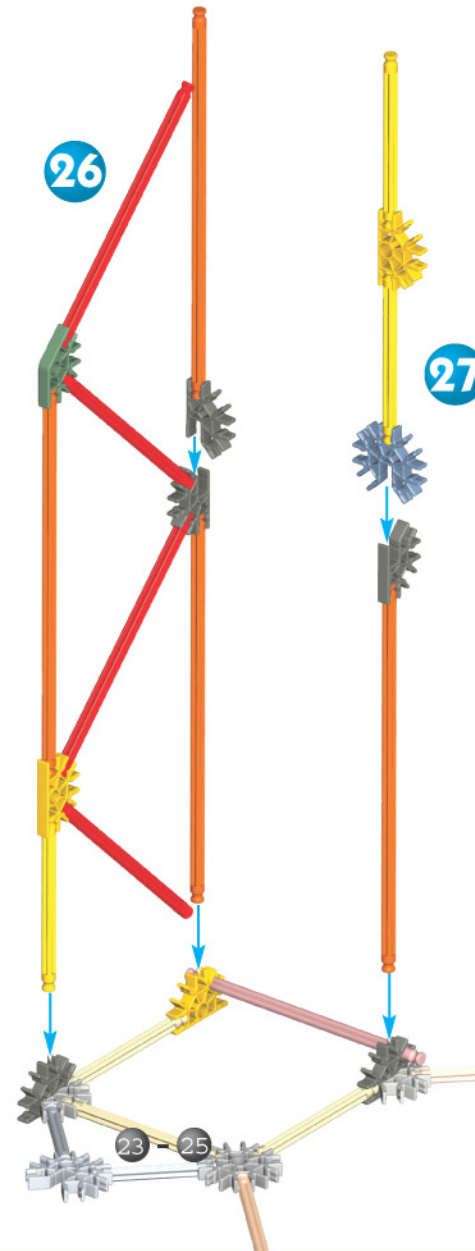

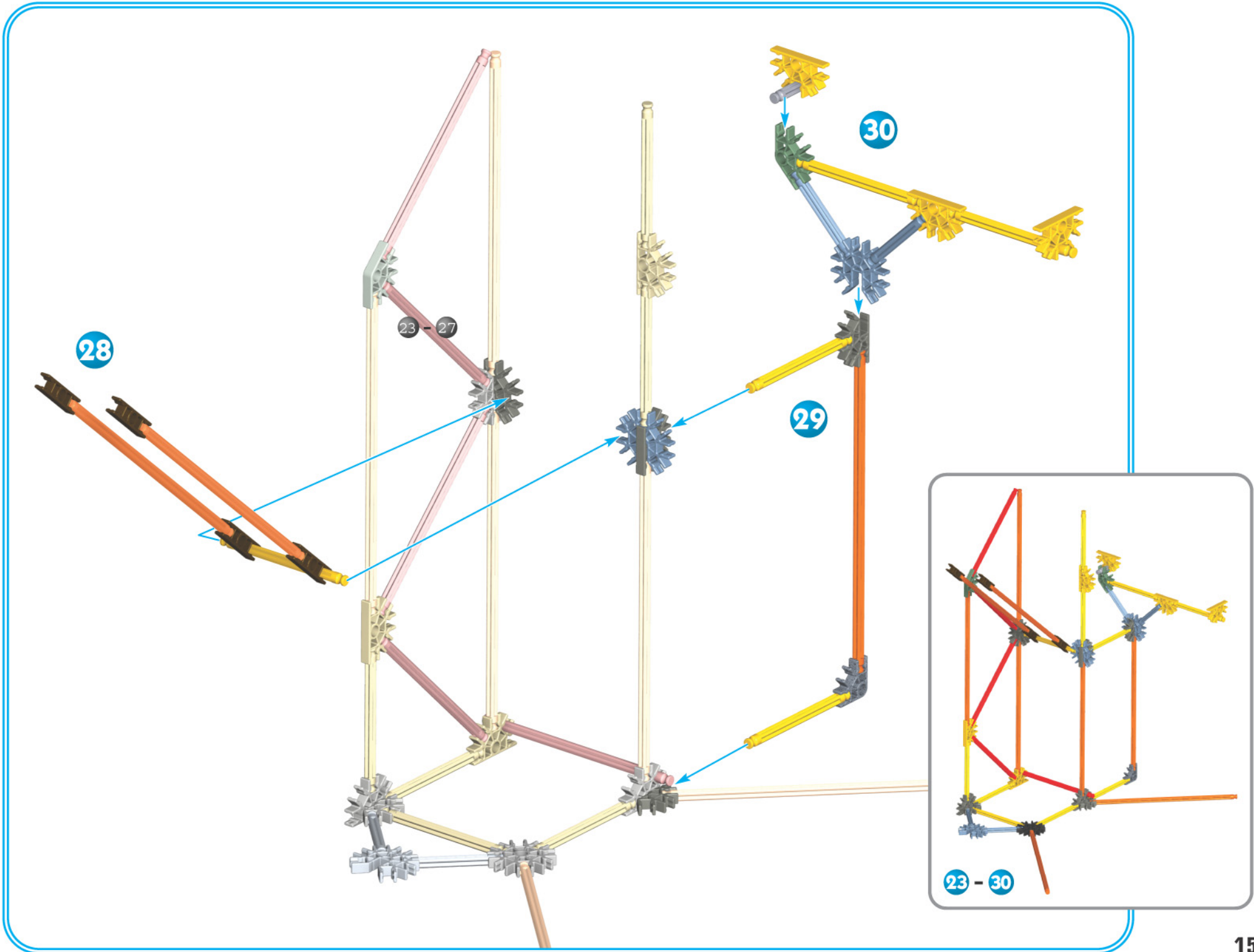

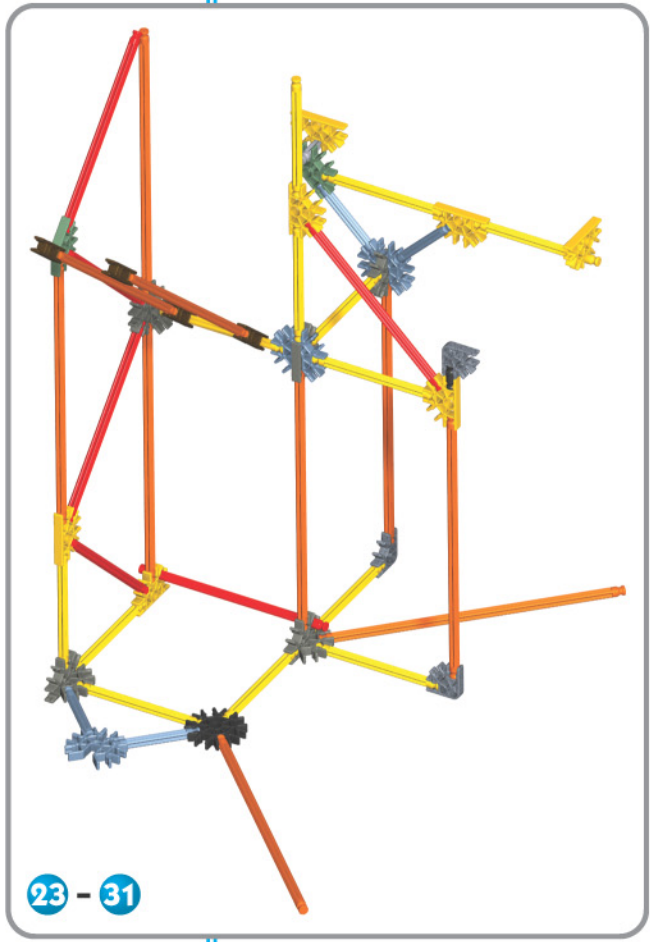
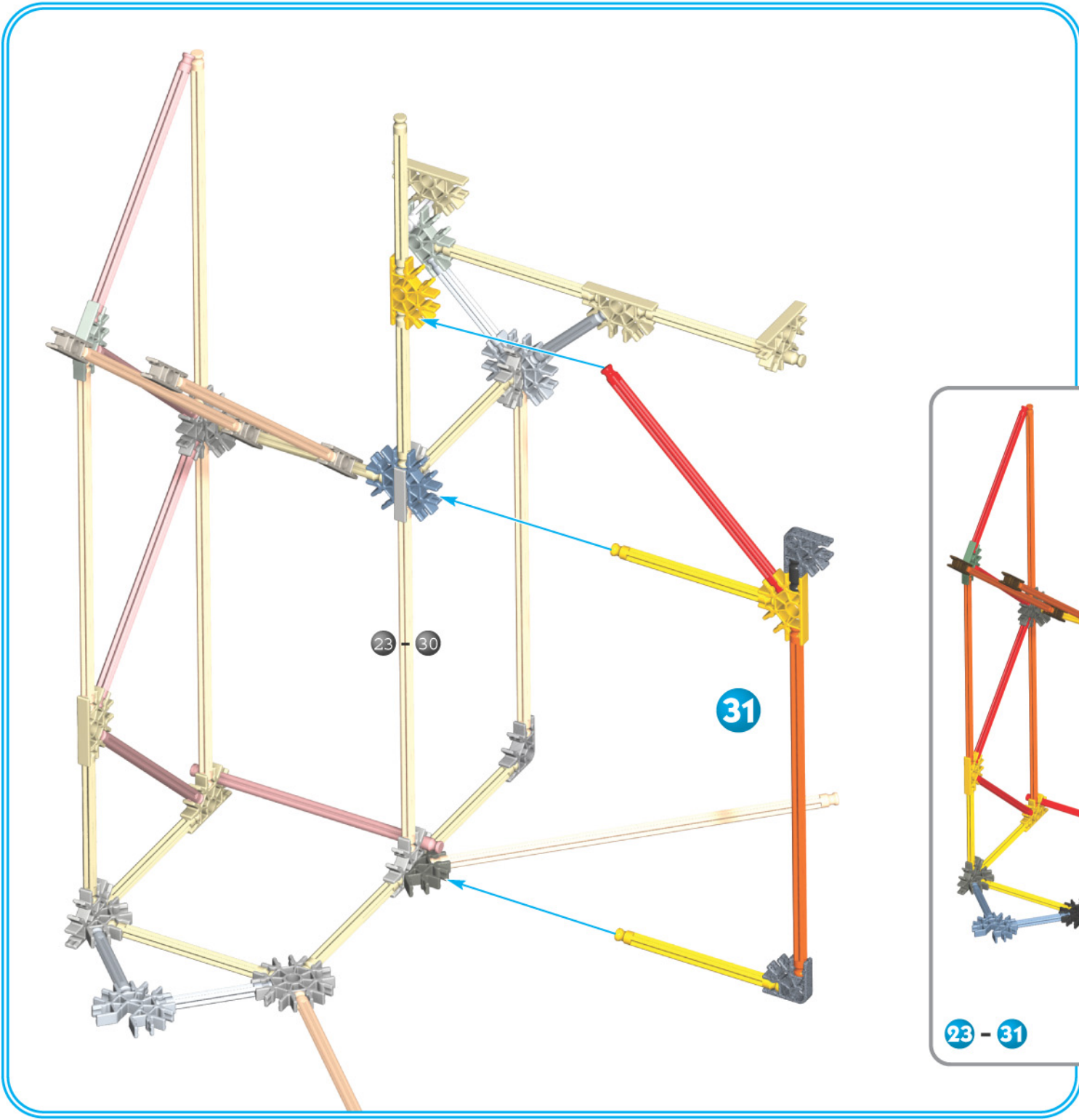

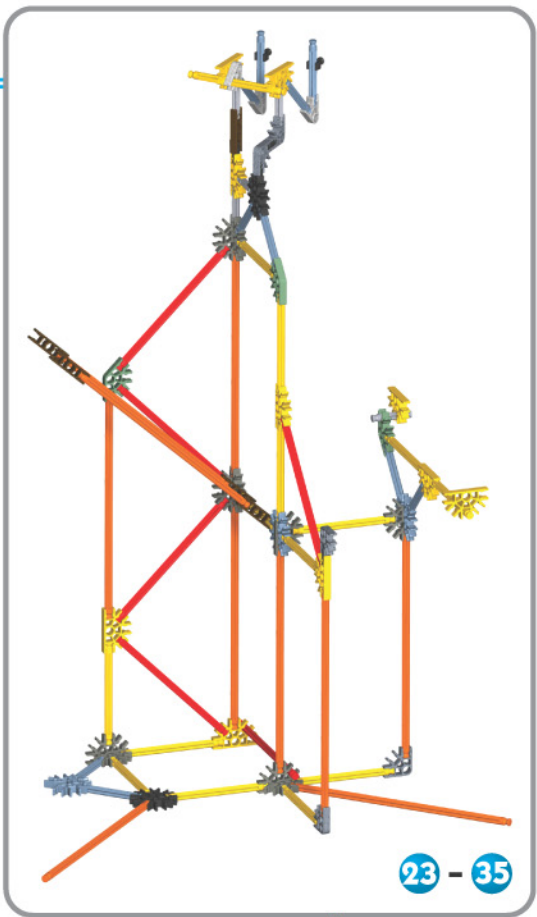
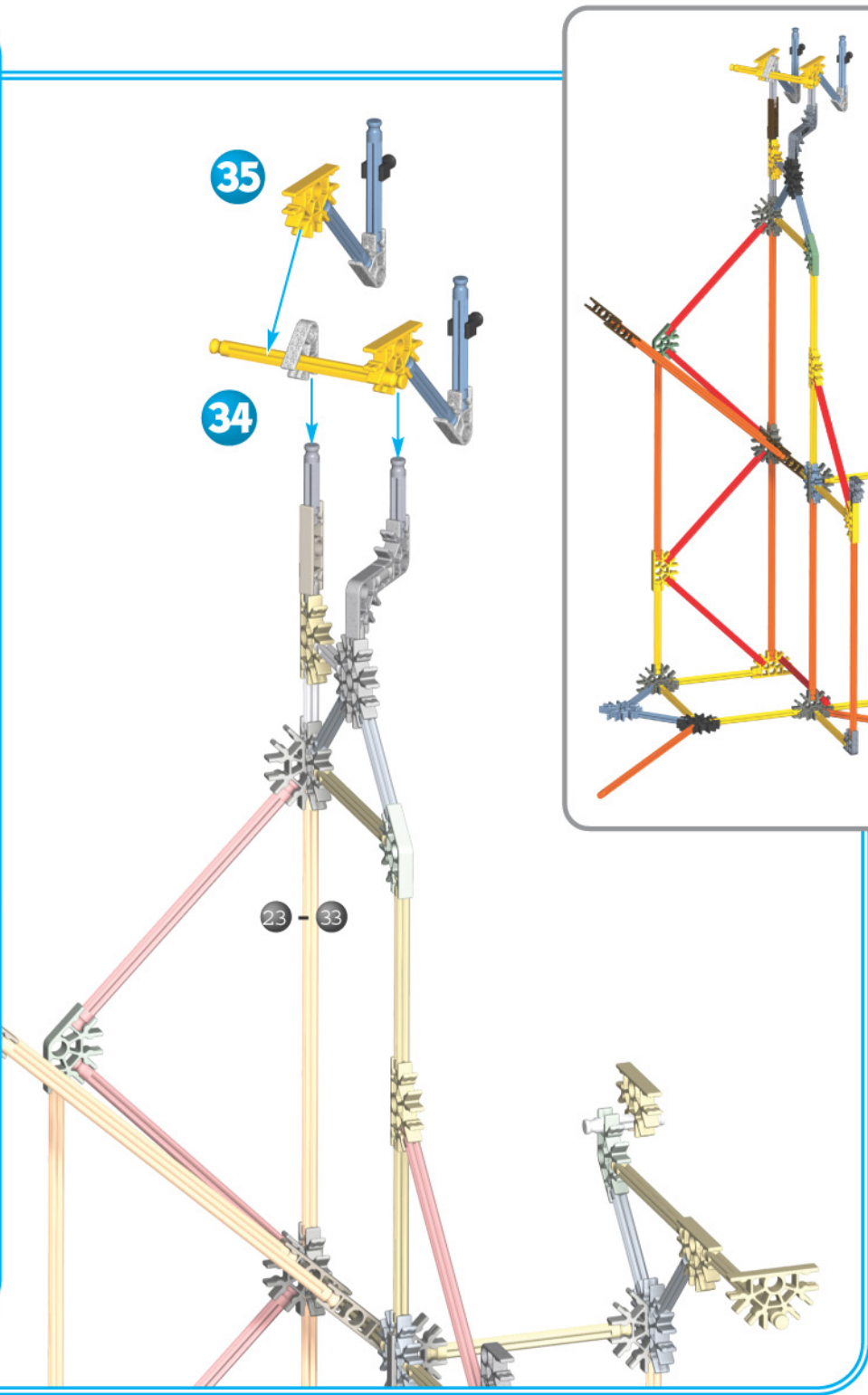
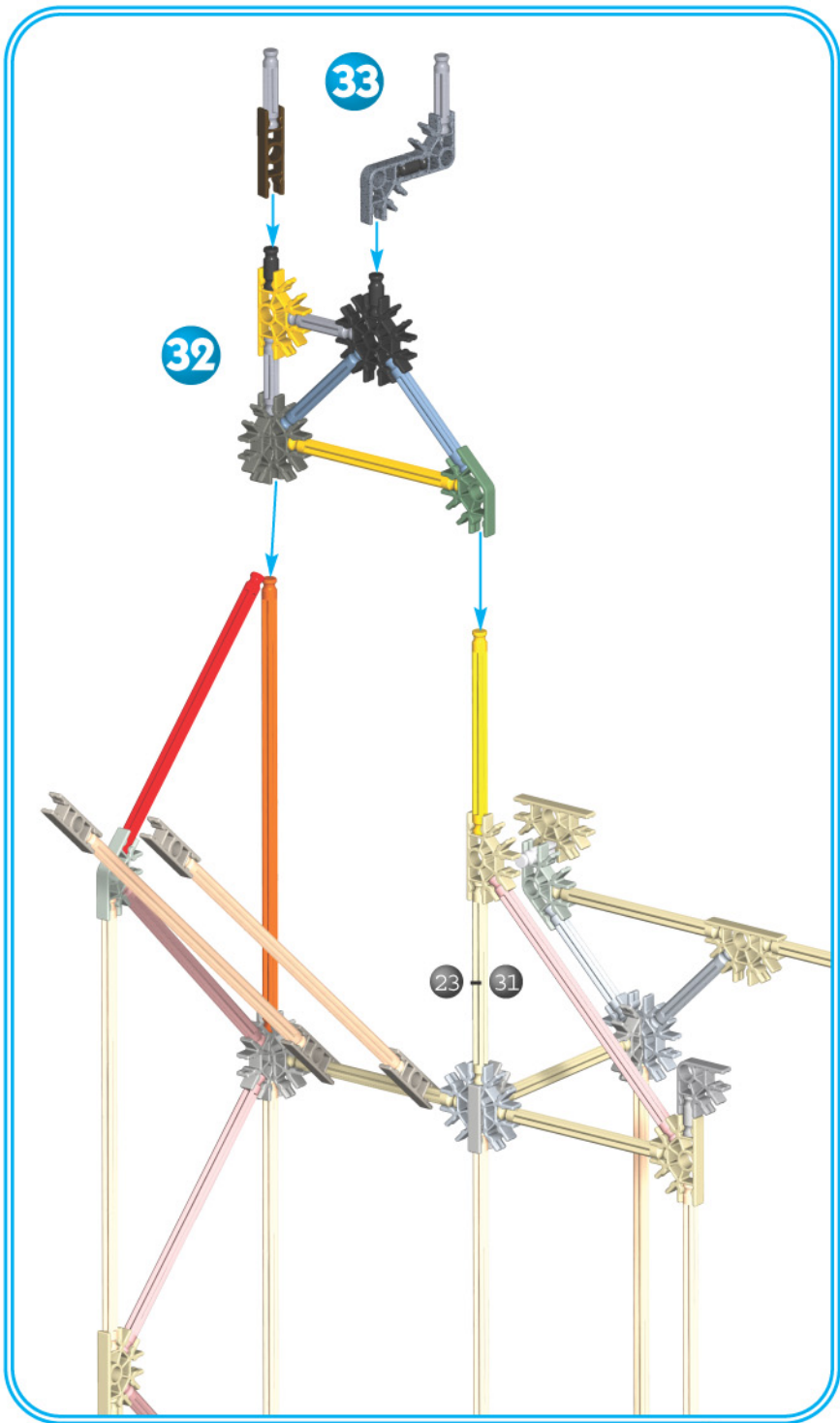



- ENG Join Section 1 to 2.
- F Joins section 1 à 2.
- E Junta la sección 1 con la sección 2.
- D Verbinde Abschnitt 1 mit Abschnitt 2.
- NL Maak deel 1 vast aan deel 2.
- I Collegare la sezione 1 alla 2.
- P Junta a secção 1 à secção 2.

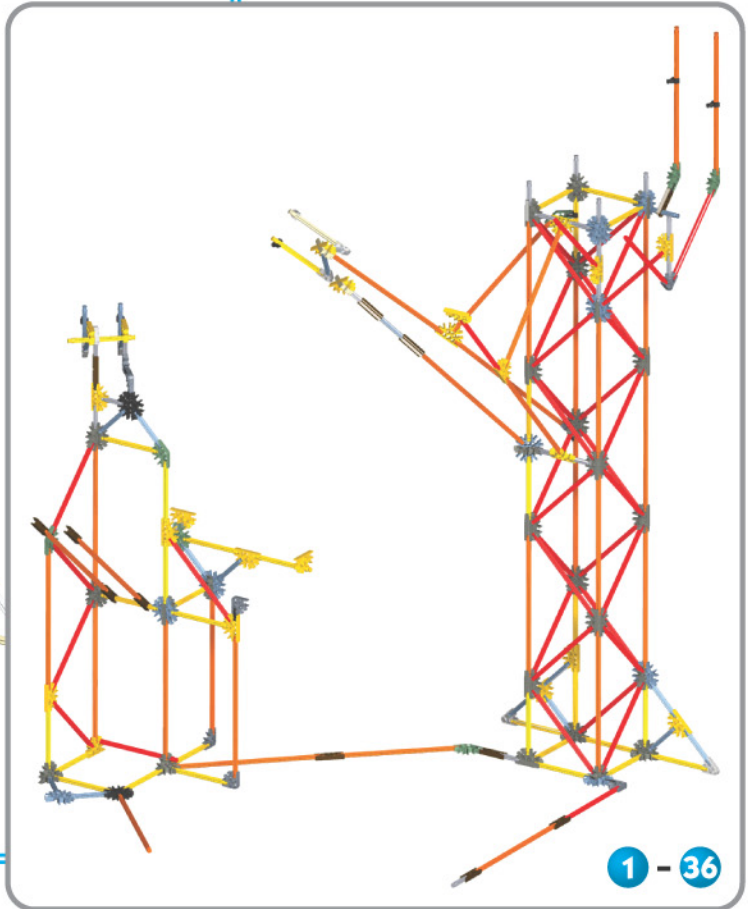
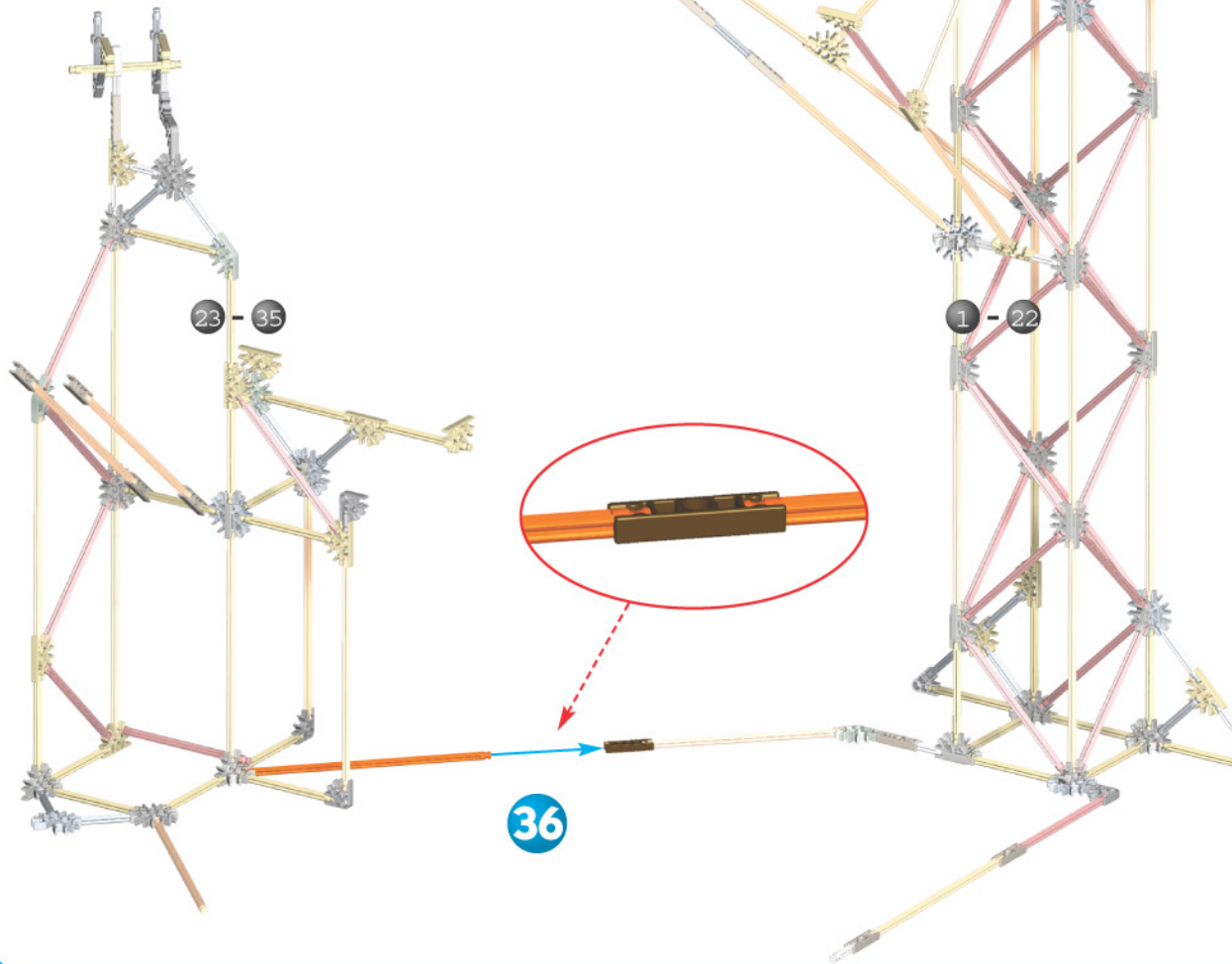

**37**

**38**

**39**

**SECTION 3**

- (F) Section 3
- (E) Sección 3
- (D) Abschnitt 3
- (ML) Deel 3
- (I) Sezione 3
- (P) Secção 3

**40**

**41**

**42**

**37 - 39**

**37 - 42**

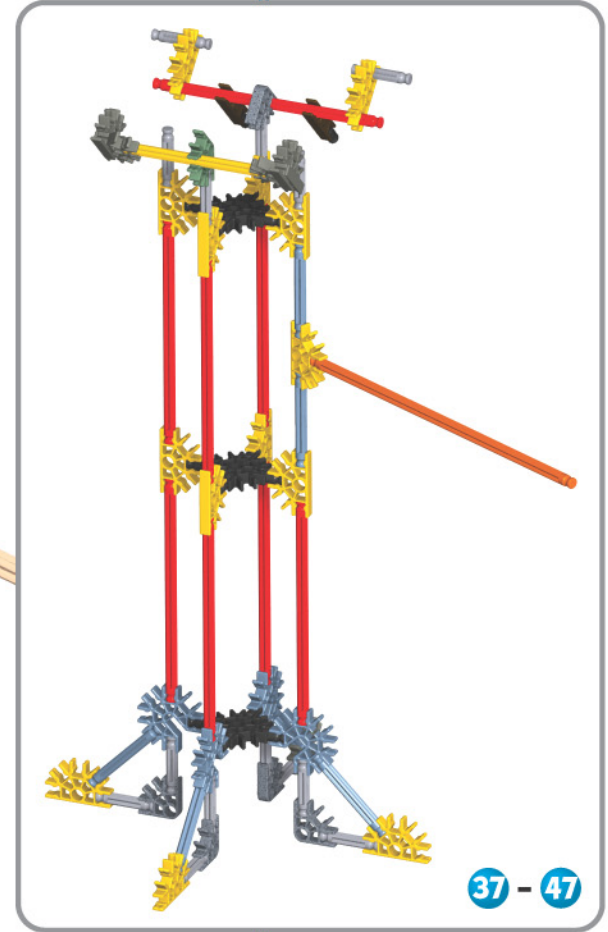
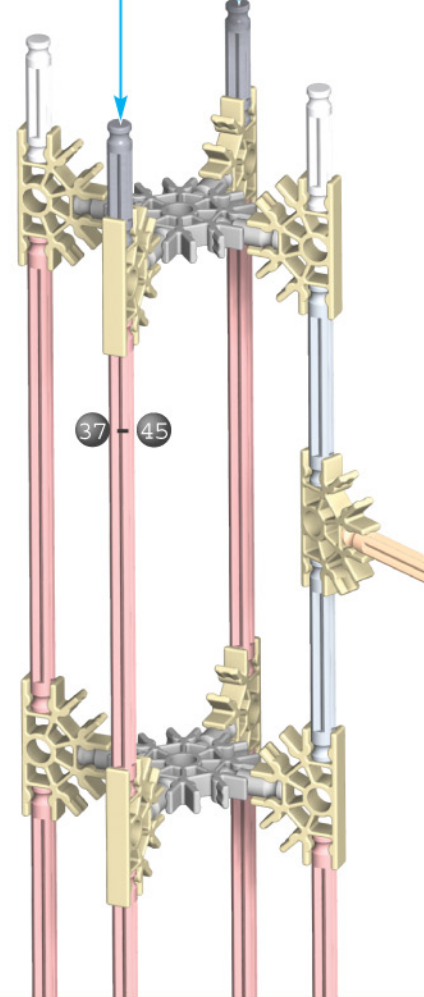
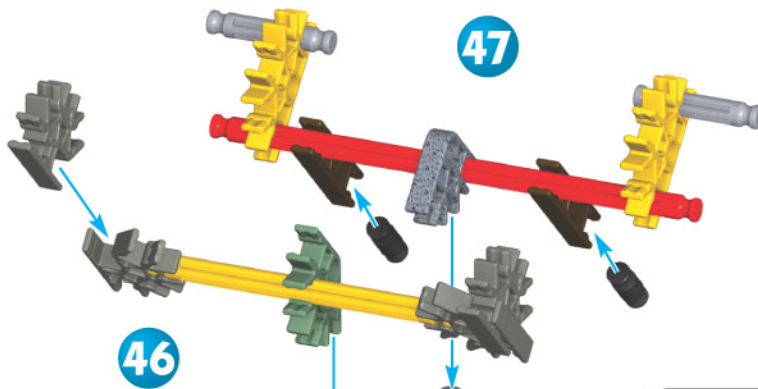
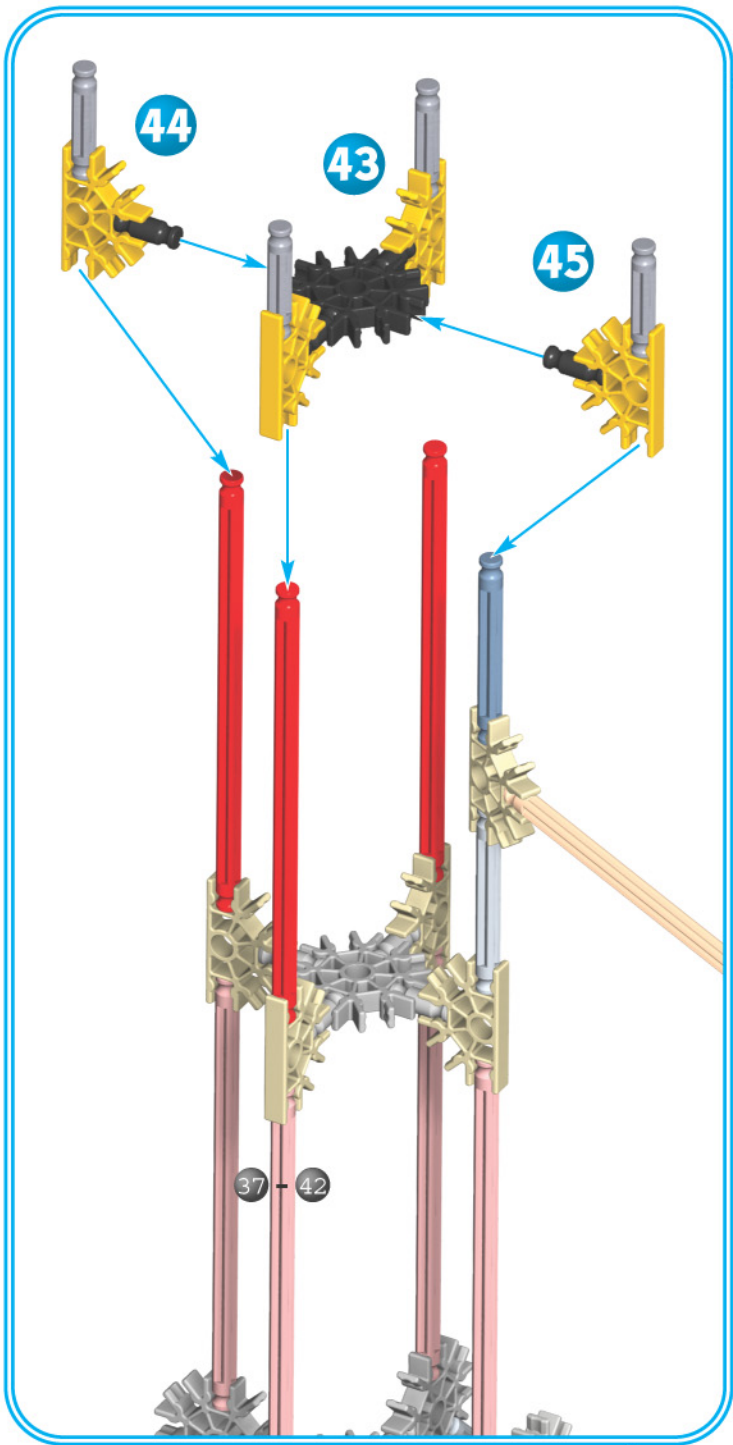

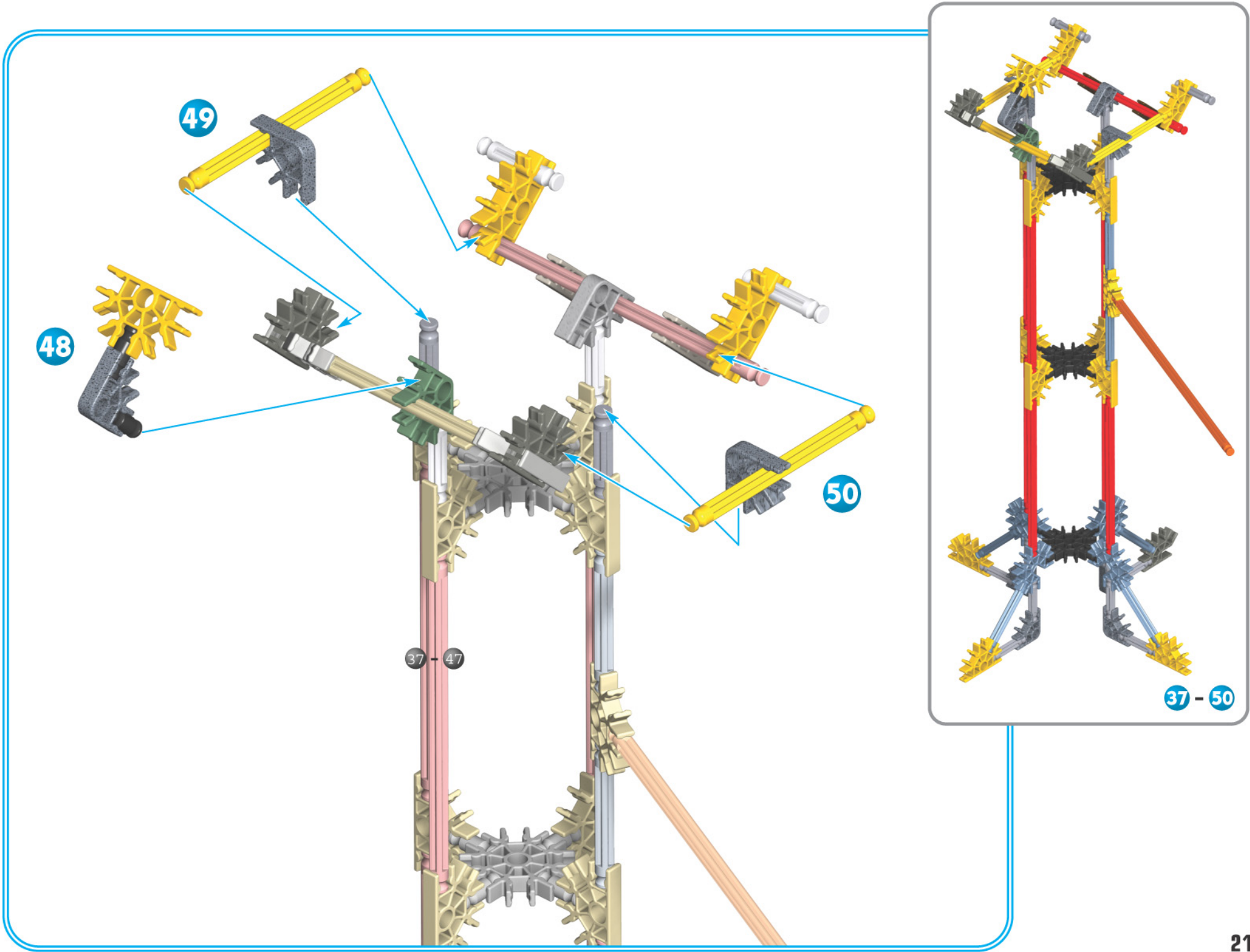

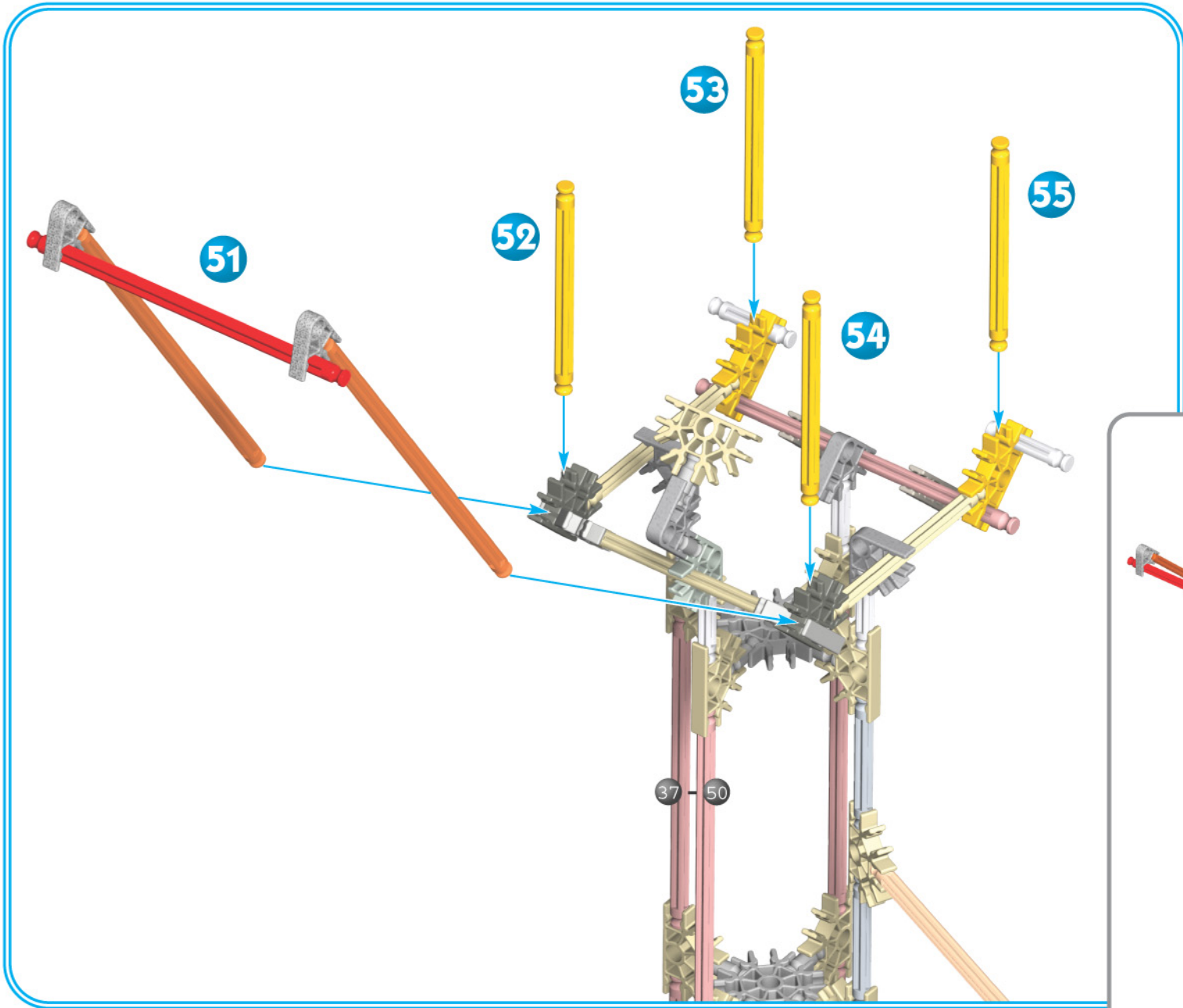



- ENG** Join Section 3 to the built Sections.
- F** Joins la section 3 aux sections déjà assemblées.
- E** Junta la sección 3 con las secciones ya construidas.
- D** Verbinde Abschnitt 3 mit den fertigen Abschnitten.
- NL** Voeg deel 3 aan de gebouwde delen.
- I** Collegare la sezione 3 alle sezioni costruite.
- P** Junta a secção 3 às secções construídas.

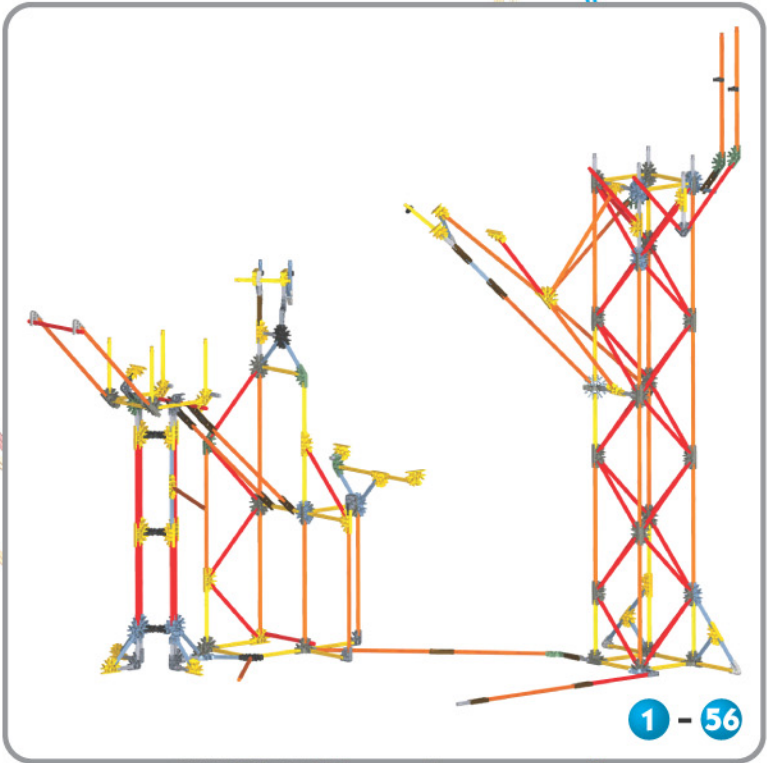
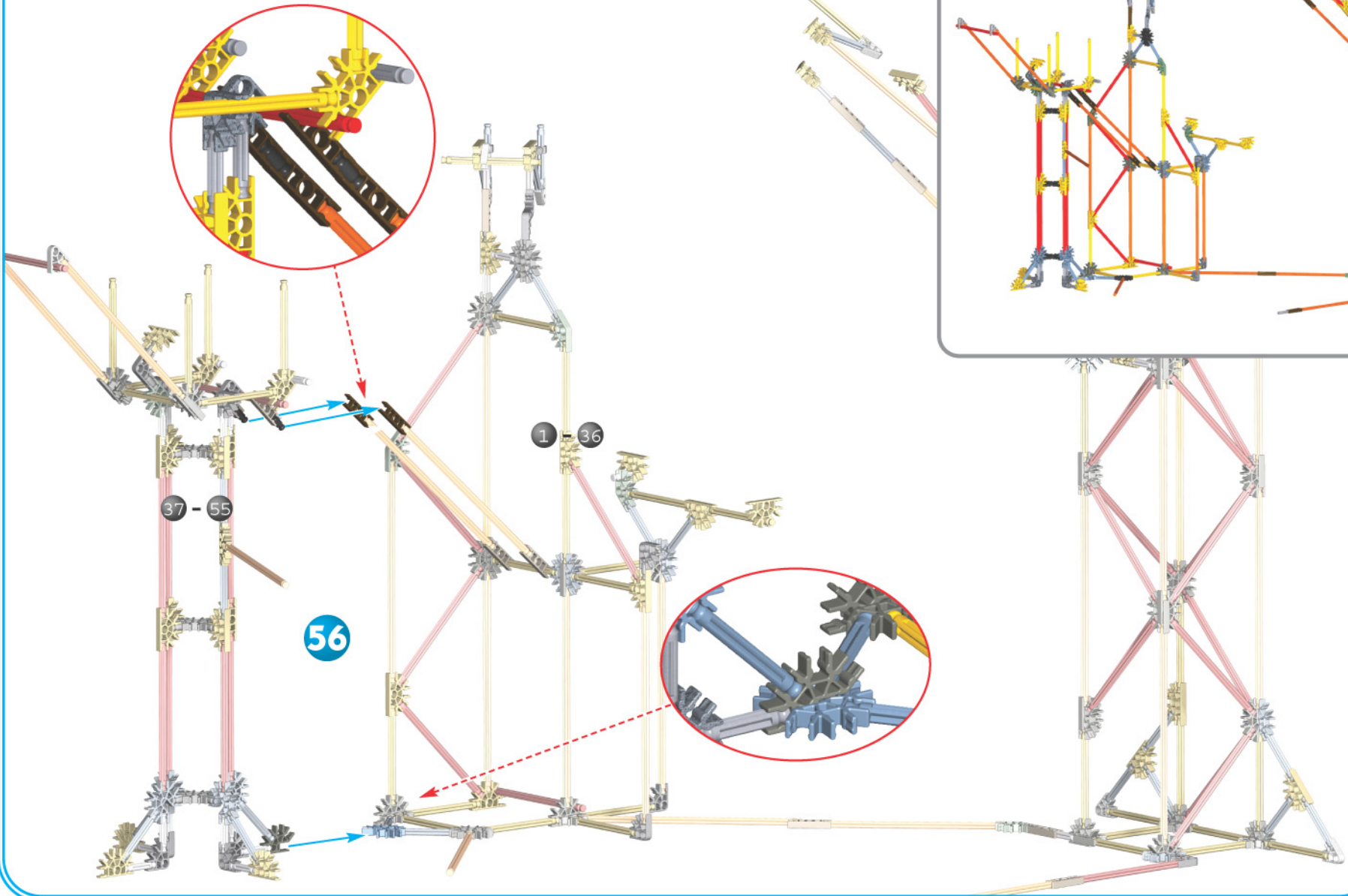

**SECTION 4**

- (F) Section 4
- (E) Sección 4
- (D) Abschnitt 4
- (NL) Deel 4
- (I) Sezione 4
- (P) Secção 4

**57 - 62**

**60**

**61**

**62**

**57 - 59**

- (ENG) Line up grooves on blue Tube and Holder, then push together tightly.
- (F) Aligner les rainures sur le tuyau bleu et l'attache, puis pousse de sorte qu'ils tiennent bien ensemble.
- (E) Alinea las muescas en el tubo azul y el soporte. Luego presiona las piezas con firmeza para que queden bien encastradas.
- (D) Die Rillen auf den blauen Röhren und den Haltern müssen aufeinander ausgerichtet sein. Drücke sie fest zusammen.
- (NL) Richt de groeven op het blauwe buisje en de houder op mekaar af en duw ze dan goed tezamen.
- (I) Allineare i solchi sul tubo blu e il supporto, quindi premere insieme saldamente.
- (P) Alinha as ranhuras no Tubo Azul e no Fixador, seguidamente, empurra firmemente umas contra as outras.

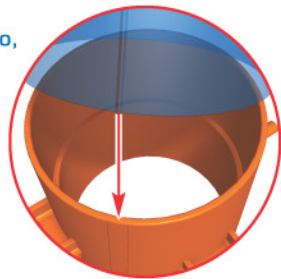

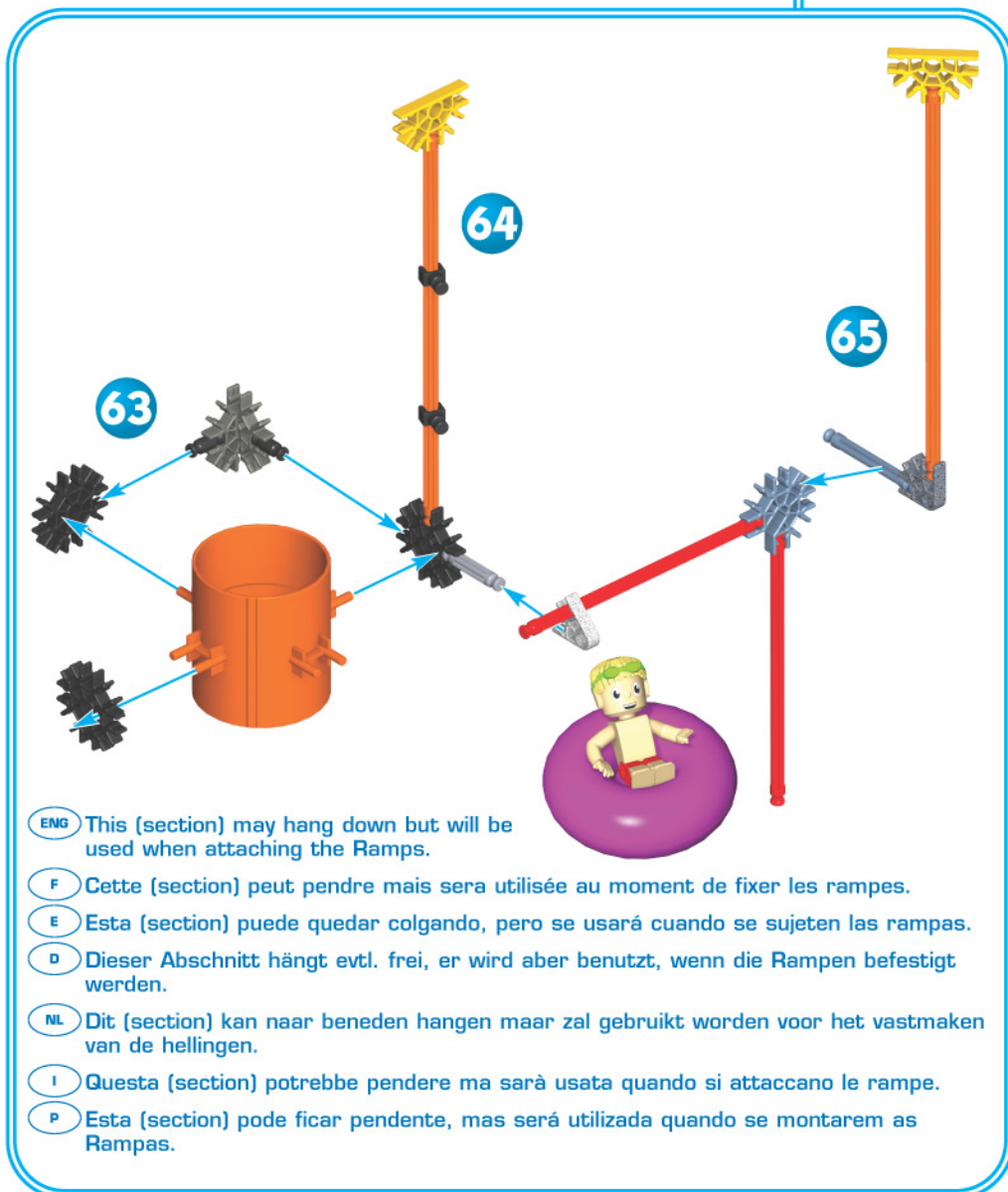

- ENG This (section) may hang down but will be used when attaching the Ramps.
- F Cette (section) peut pendre mais sera utilisée au moment de fixer les rampes.
- E Esta (section) puede quedar colgando, pero se usará cuando se sujeten las rampas.
- D Dieser Abschnitt hängt evtl. frei, er wird aber benutzt, wenn die Rampen befestigt werden.
- NL Dit (section) kan naar beneden hangen maar zal gebruikt worden voor het vastmaken van de hellingen.
- I Questa (section) potrebbe pendere ma sarà usata quando si attaccano le rampe.
- P Esta (section) pode ficar pendente, mas será utilizada quando se montarem as Rampas.

- ENG Line up grooves on blue Tube and Holder, then push together tightly.
- F Aligne les rainures sur le tuyau bleu et l'attache, puis pousse de sorte qu'ils tiennent bien ensemble.
- E Alinea las muescas en el tubo azul y el soporte. Luego presiona las piezas con firmeza para que queden bien encastradas.
- D Die Rillen auf den blauen Röhren und den Haltern müssen aufeinander ausgerichtet sein. Drücke sie fest zusammen.
- NL Richt de groeven op het blauwe buisje en de houder op mekaar af en duw ze dan goed tezamen.
- I Allineare i solchi sul tubo blu e il supporto, quindi premere insieme saldamente.
- P Alinha as ranhuras no Tubo Azul e no Fixador, seguidamente, empurra firmemente umas contra as outras.

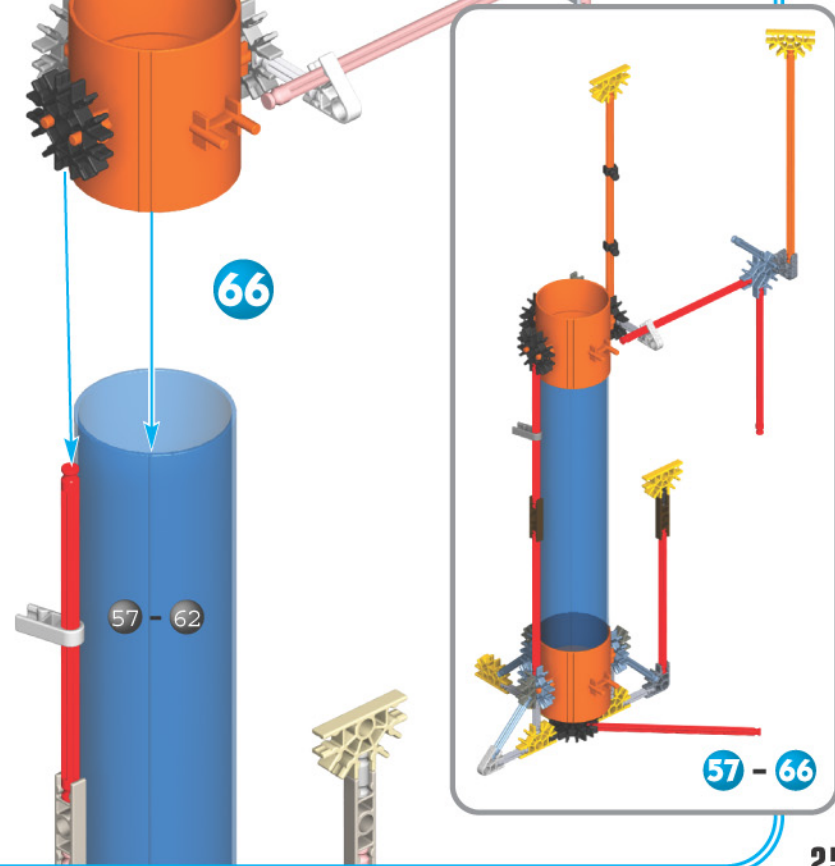



# SECTION 5

- F Section 5
- E Sección 5
- D Abschnitt 5
- NL Deel 5
- I Sezione 5
- P Seção 5

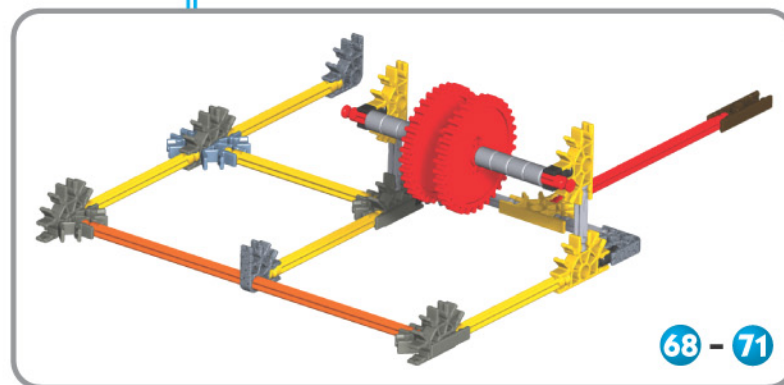
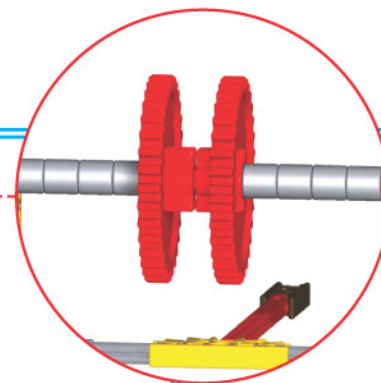
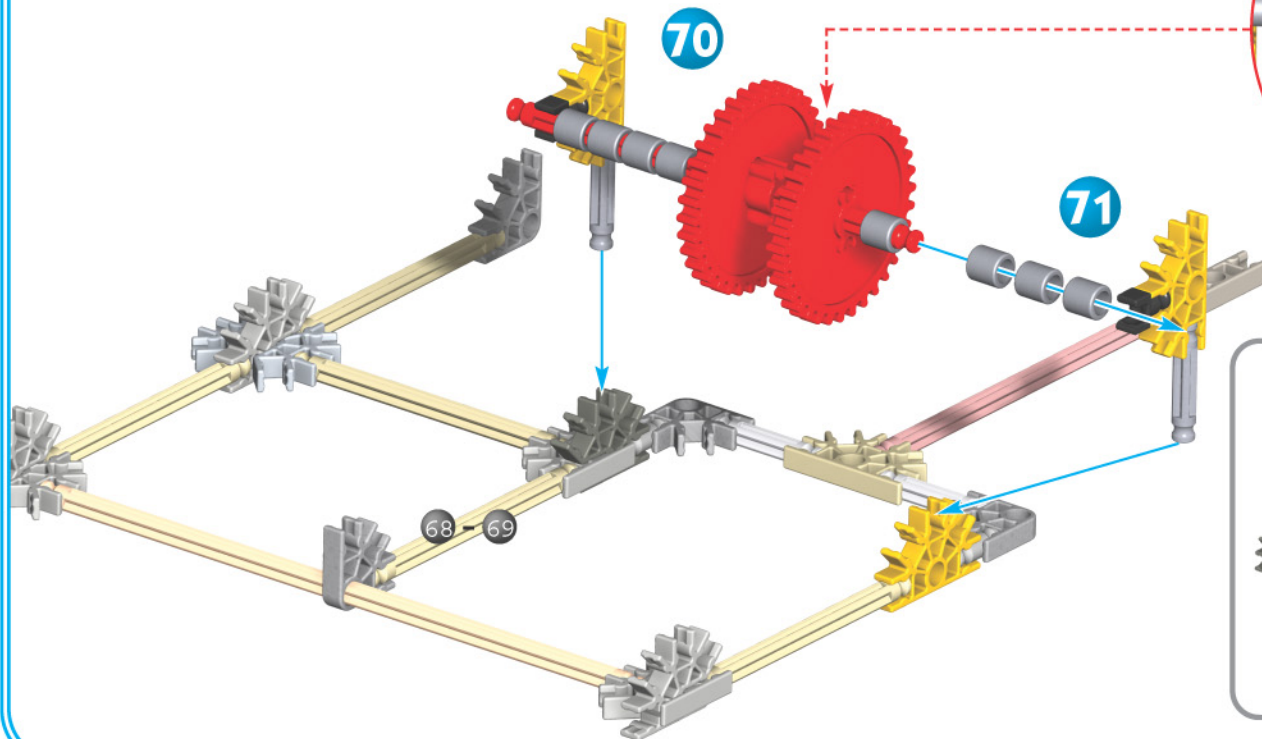
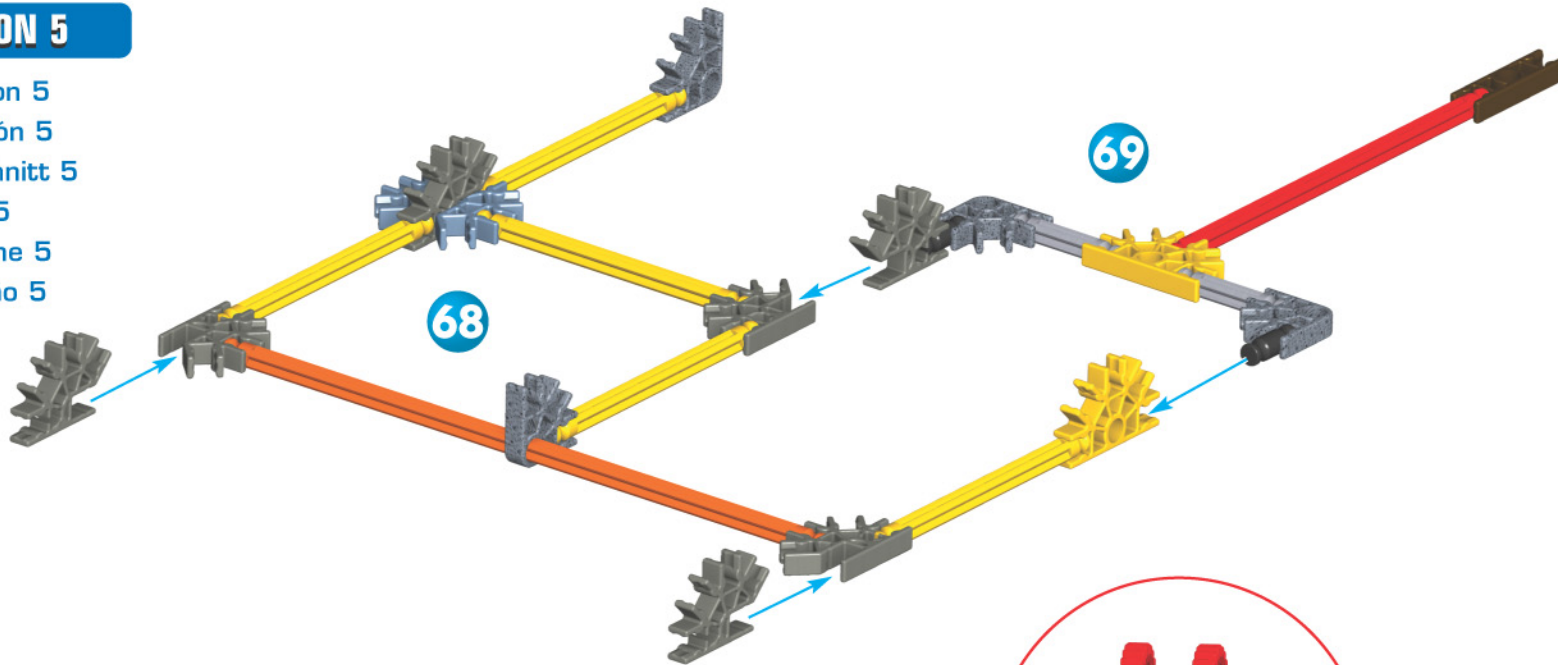

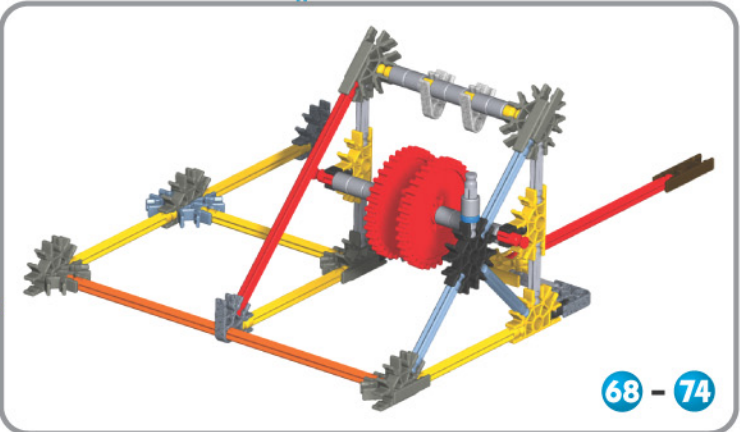
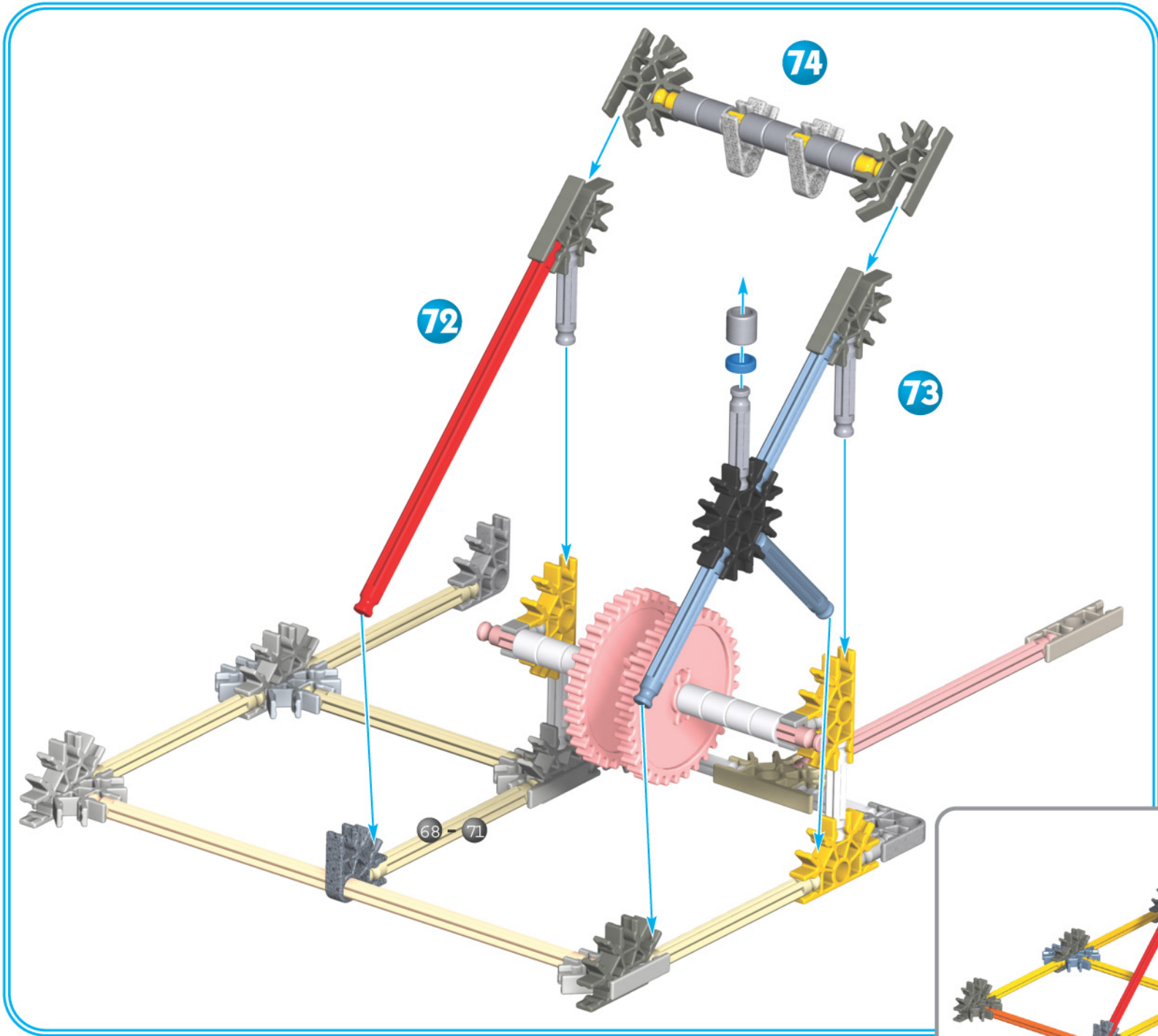

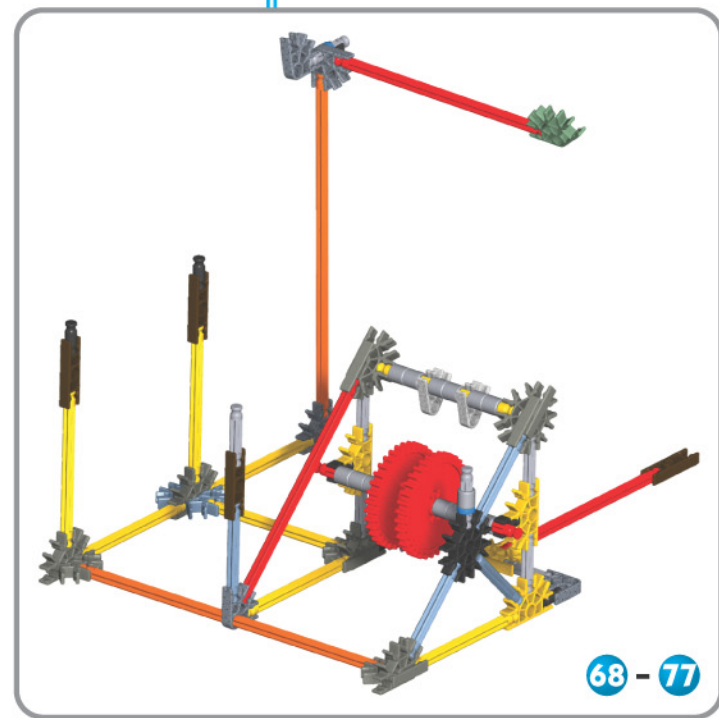
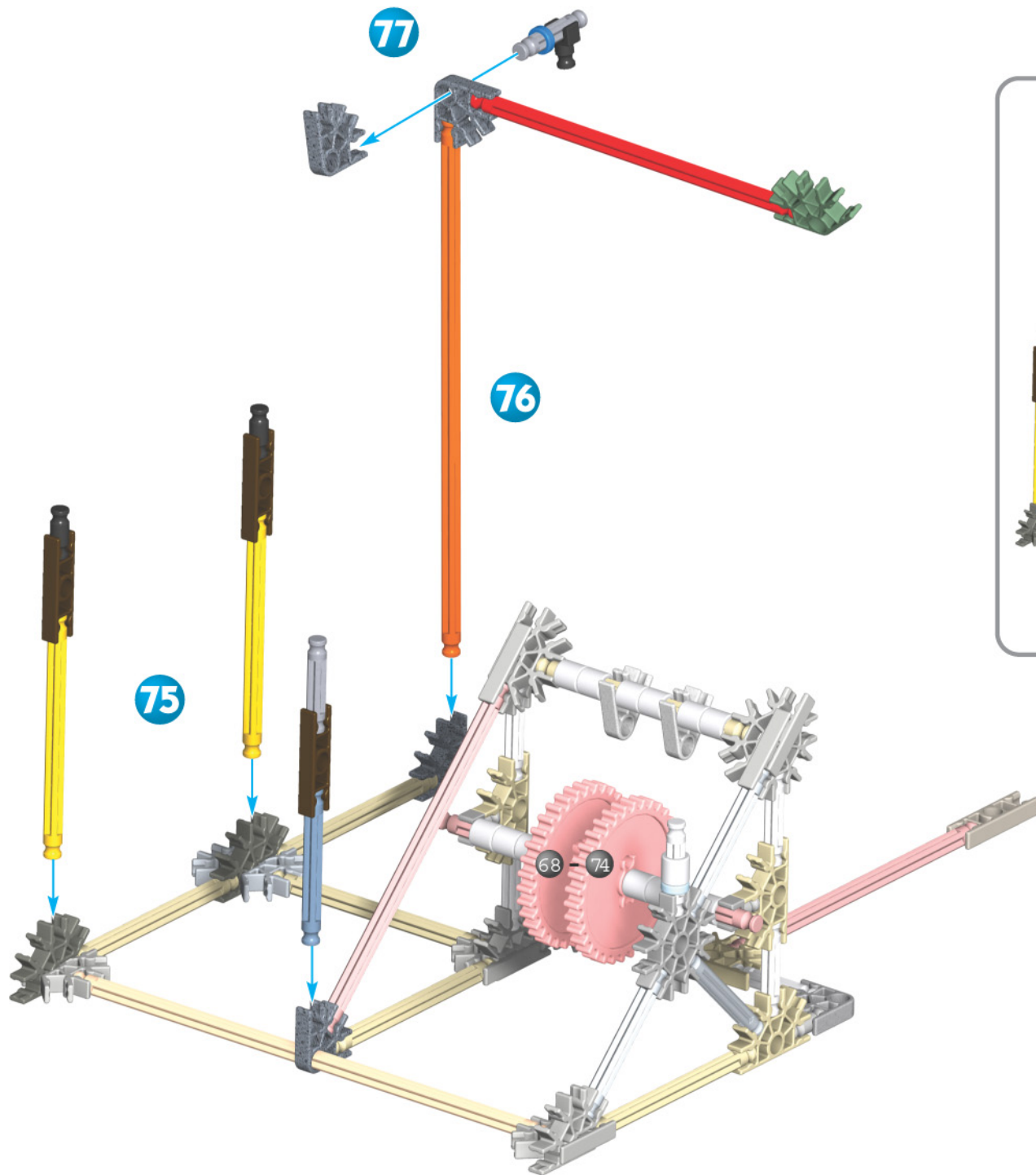

- ENG Join Section 5 to the built Sections.
- F Joins la section 5 aux sections déjà assemblées.
- E Junta la sección 5 con las secciones ya construidas.
- D Verbinde Abschnitt 5 mit den fertigen Abschnitten.
- NL Voeg deel 5 aan de gebouwde delen.
- I Collegare la sezione 5 alle sezioni costruite.
- P Junta a secção 5 às secções construídas.

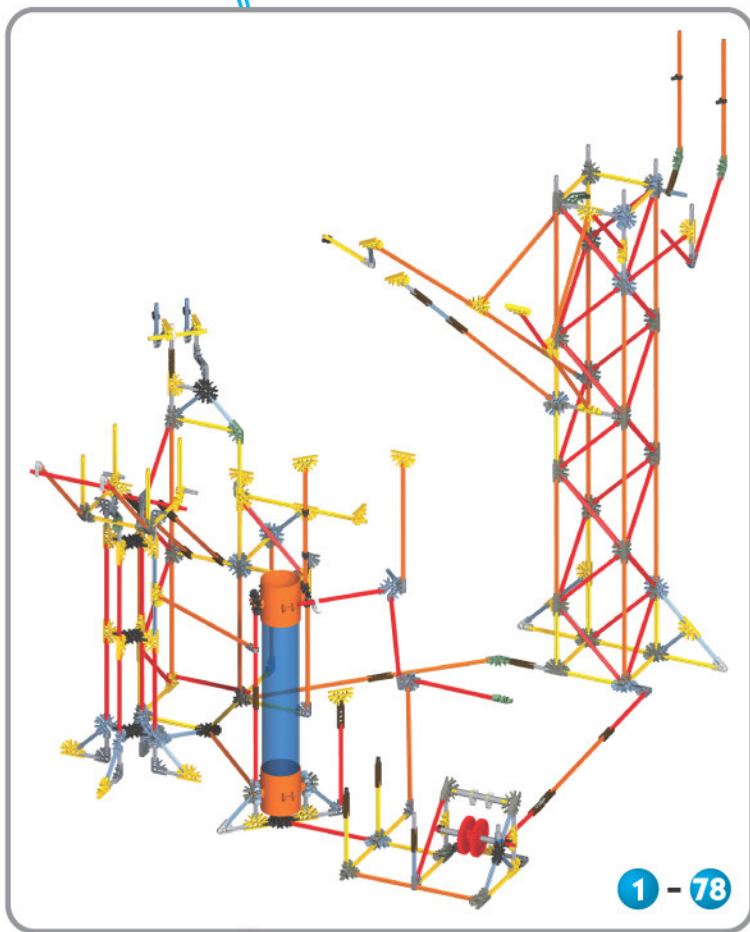
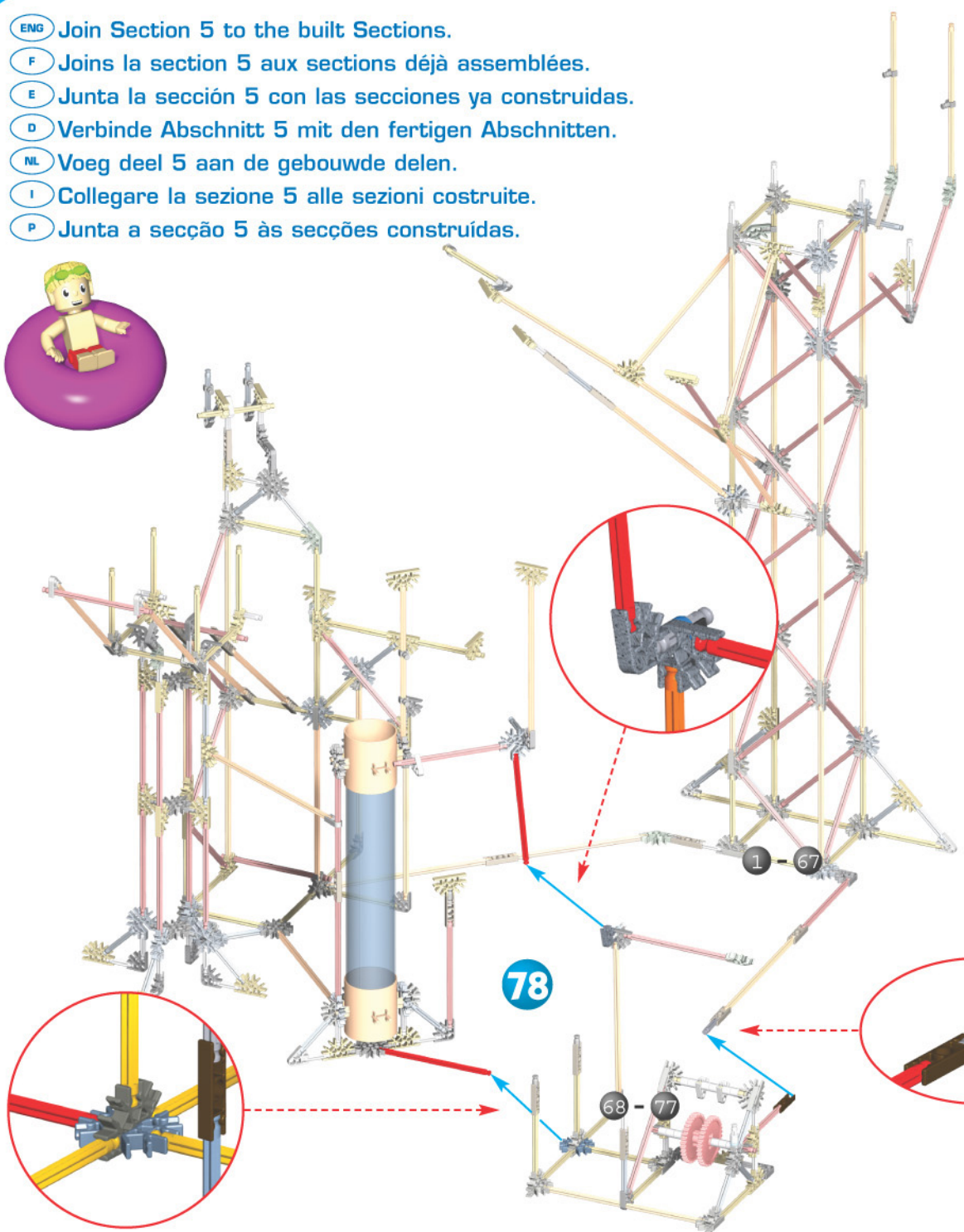



79

**SECTION 6**

- F Section 6
- E Sección 6
- D Abschnitt 6
- NL Deel 6
- I Sezione 6
- P Secção 6

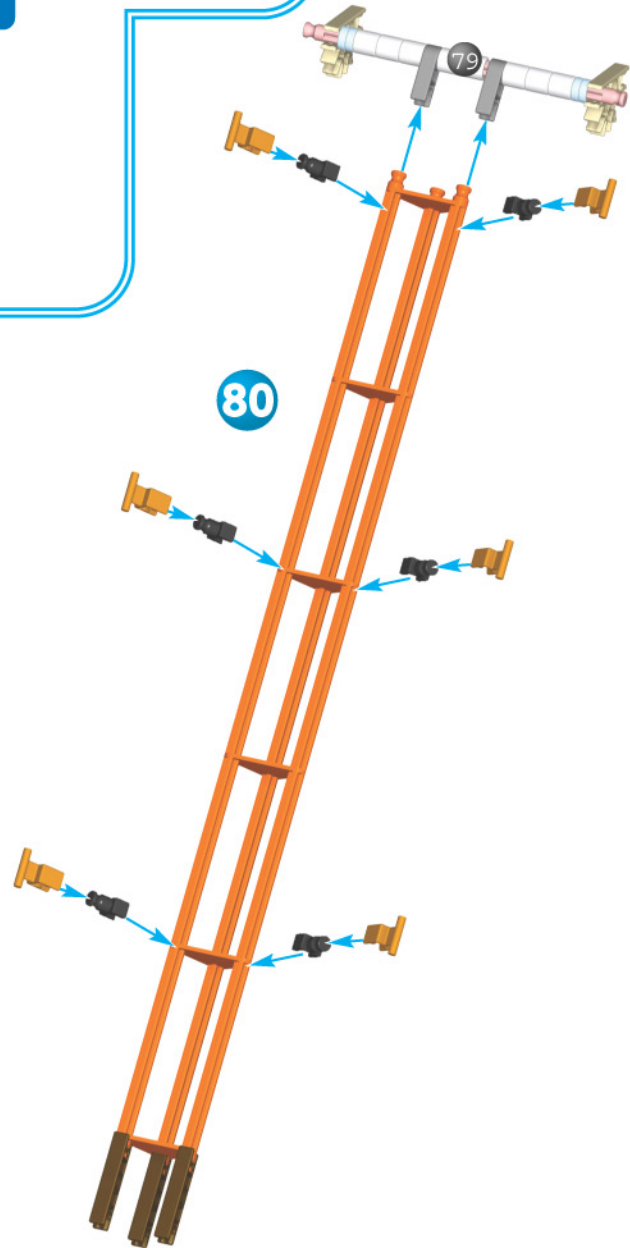

80

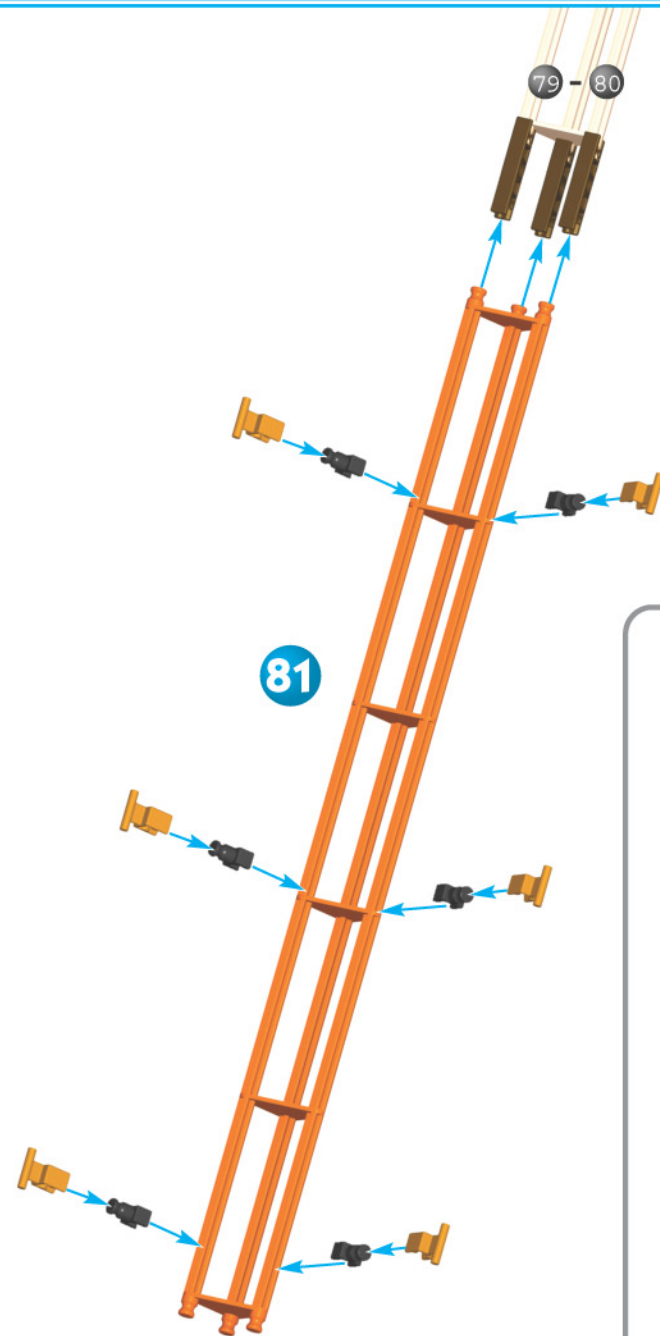

81

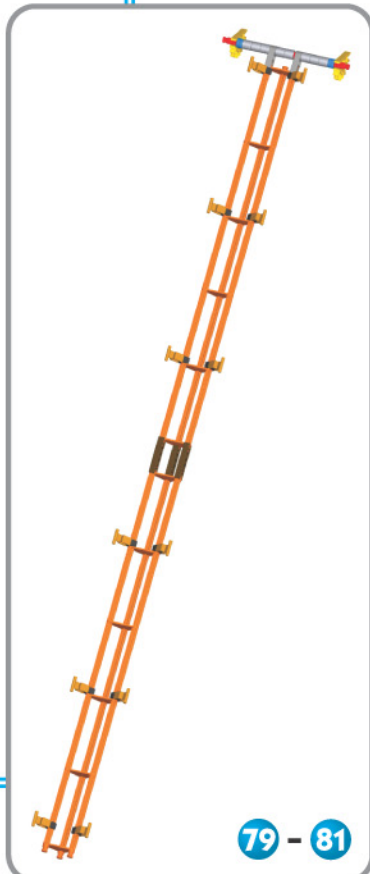

79 - 81

ENG Join Section 6 to the built Sections.

F Joins la section 6 aux sections déjà assemblées.

E Junta la sección 6 con las secciones ya construidas.

D Verbinde Abschnitt 6 mit den fertigen Abschnitten.

NL Voeg deel 6 aan de gebouwde delen.

I Collegare la sezione 6 alle sezioni costruite.

P Junta a secção 6 às secções construídas.

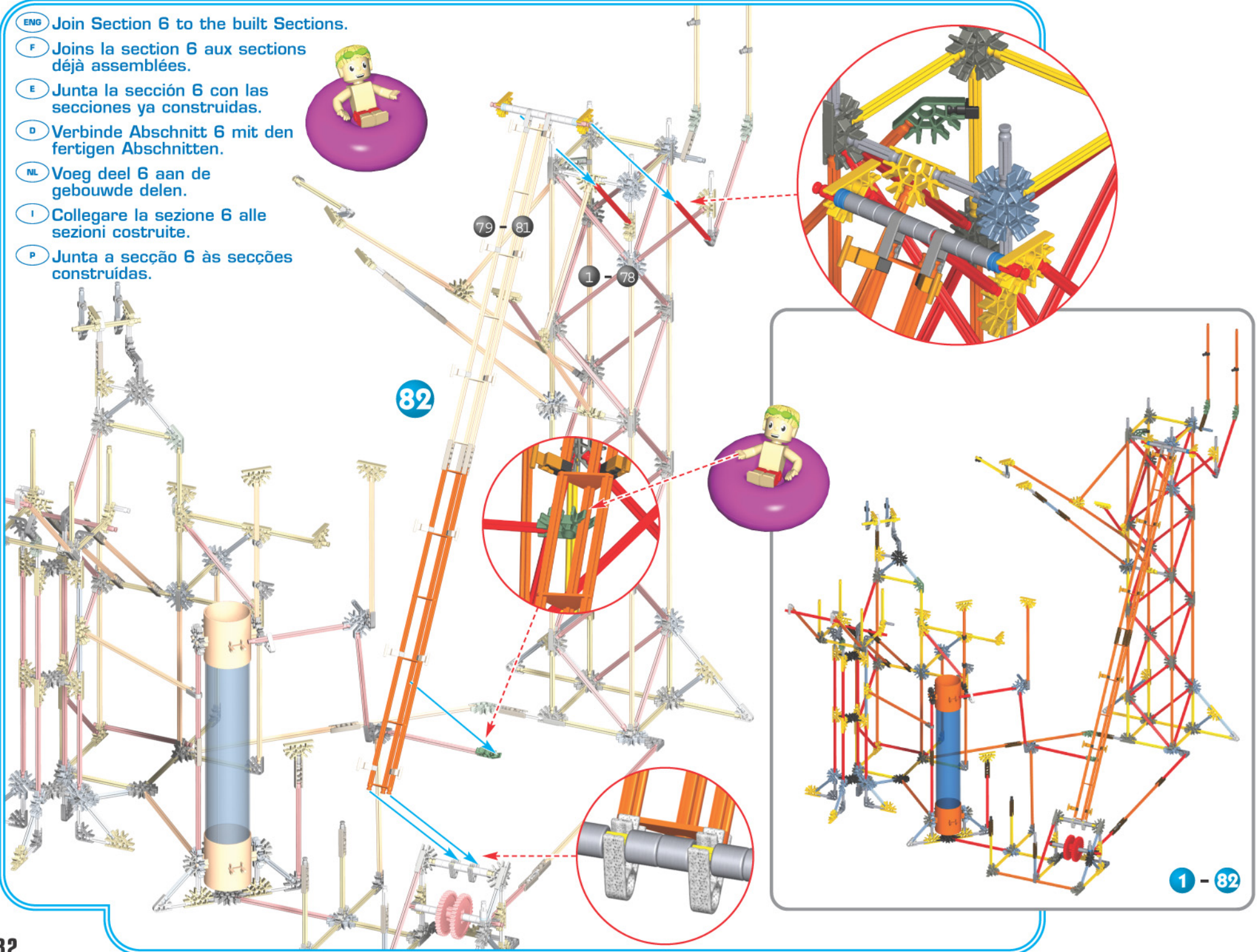

83

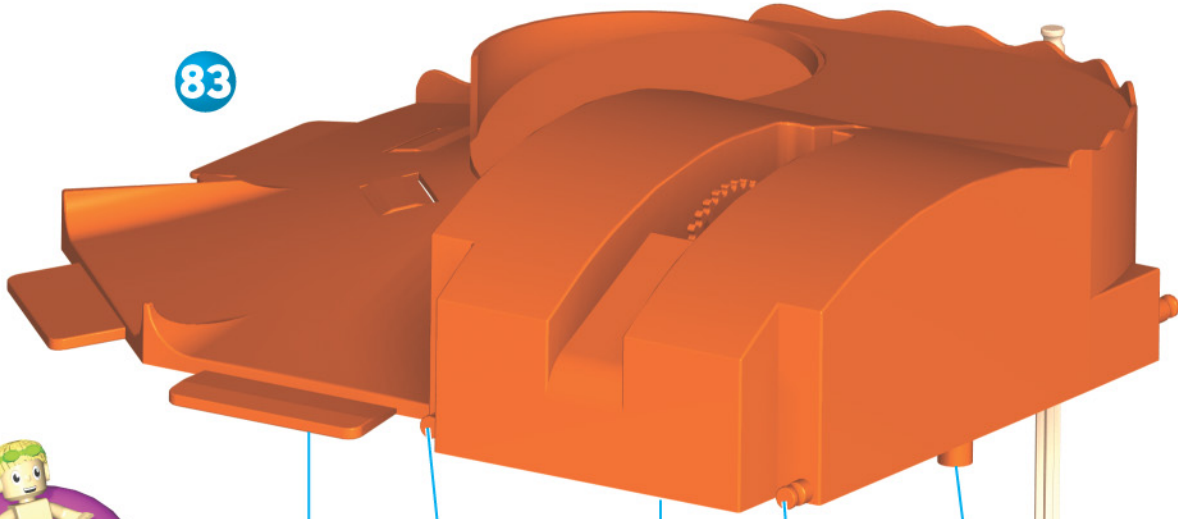

- ENG Did you install 3 C (LR14) Batteries?
- F As-tu installé 3 piles C (ou LR14) ?
- E ¿Instalaste 3 pilas C (o LR14)?
- D Hast du 3 Batterien der Baugröße C (oder LR14) eingelegt?
- NL Heb je er 3 C (of LR14) batterijen ingestoken?
- I Hai installato le batterie 3 C (o LR14)?
- P As 3 pilhas C (ou LR14) já estão instaladas?



- ENG Holes for Rods.
- F Trous pour les tiges.
- E Agujeros para insertar las varillas.
- D Löcher für die Stäbe.
- NL Gaten voor de stangen.
- I Fori per le aste.
- P Orificios para as Hastes.

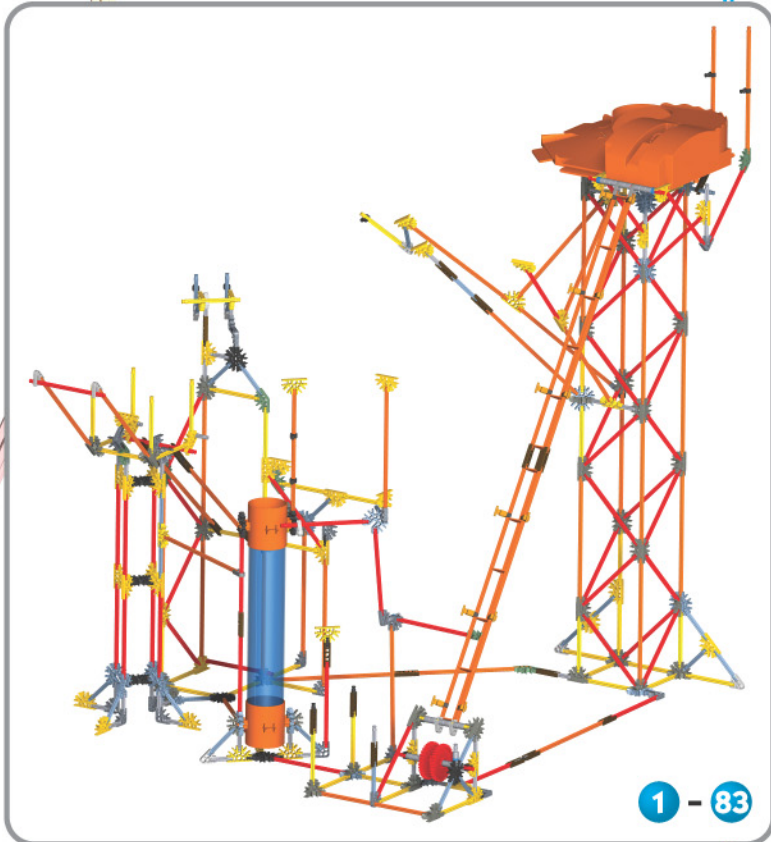

1 - 83



84

23

x4

 x92

- (ENG) Attach Chain Links in the same direction. The hooks should face up as they go uphill on the model.
- (F) Fixe les maillons de la chaîne dans le même sens. Les crochets doivent être tournés vers le haut vu qu'ils montent la pente sur le modèle.
- (E) Conecta los eslabones de la cadena en la misma dirección. Los ganchos deben estar orientados hacia arriba a medida que van ascendiendo en el modelo.
- (D) Bringe die Kettenglieder in der gleichen Richtung an. Die Haken müssen bei der Aufwärtsbewegung nach oben zeigen.
- (NL) Maak de kettingschakels vast in dezelfde richting. De haken moeten naar boven gericht zijn terwijl ze de helling van het model oplopen.
- (I) Collegare le maglie della catena nella stessa direzione. I ganci dovrebbero essere rivolti verso l'alto mentre si spostano verso l'alto sul modello.
- (P) Prende os Elos de União da Corrente seguindo a mesma direção. Os ganchos devem estar voltados para cima quando em movimento ascendente no modelo.



85

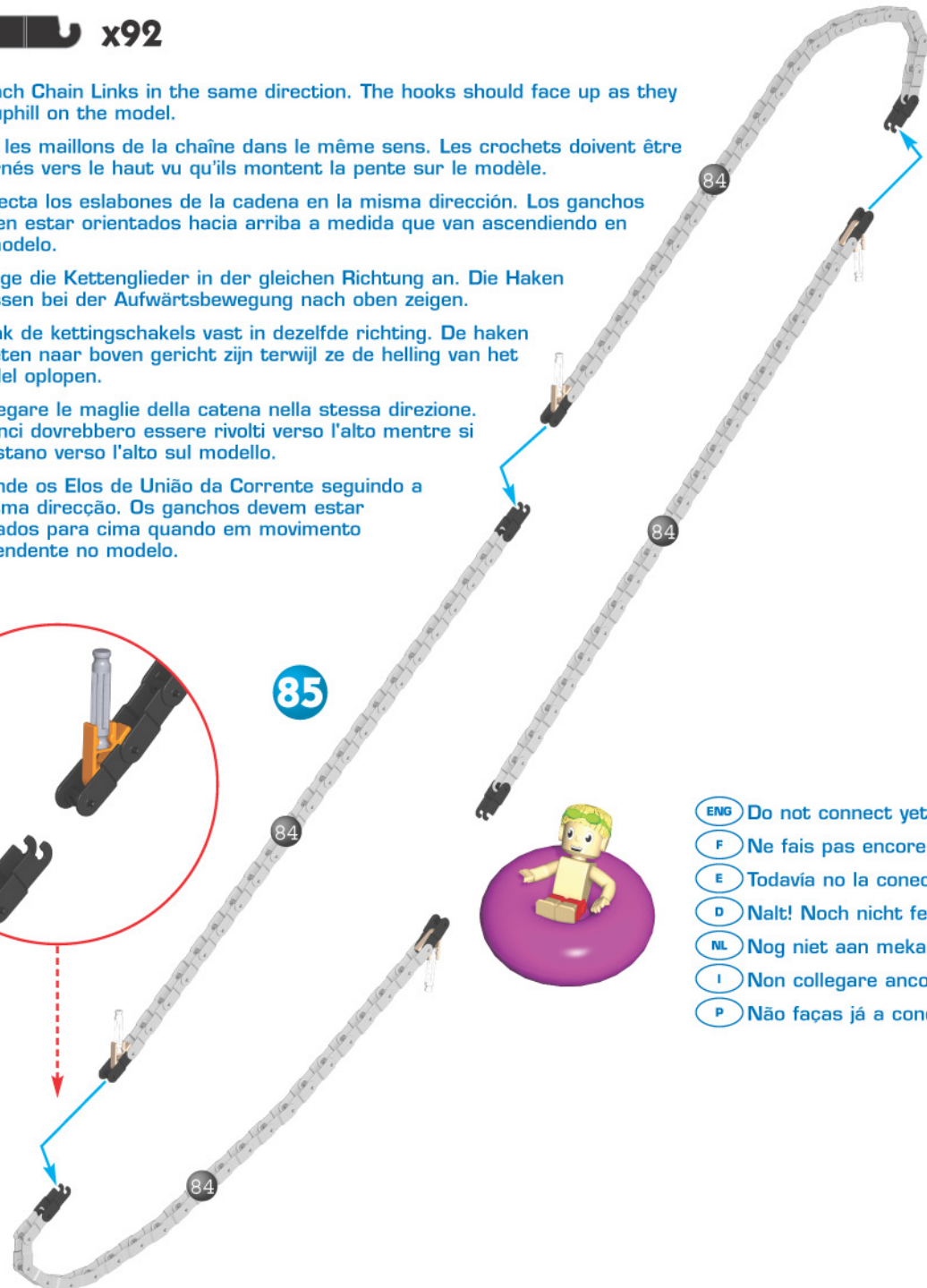

- (ENG) Do not connect yet.
- (F) Ne fais pas encore la connexion.
- (E) Todavía no la conectes.
- (D) Nalt! Noch nicht festmachen.
- (NL) Nog niet aan mekaar koppelen.
- (I) Non collegare ancora.
- (P) Não faça já a conexão.

- ENG** The "pick-up" Rods face up.
- F** Les tiges de « ramassage » sont tournées vers le haut.
- E** Las varillas con agarraderas se orientan hacia arriba.
- D** Diese Förderstäbe müssen nach oben zeigen.
- NL** De "pick-up" stangen zijn naar boven gericht.
- I** Le aste di "sollevamento" sono rivolte verso l'alto.
- P** As Hastes "acopladoras" apresentam-se viradas para cima.

- ENG** Drop chain down through the Motor at the top, then down and around the red Gears at the bottom. Then attach the Chain together on the under side.
- F** Fais tomber la chaîne en la faisant passer à travers le moteur en haut et autour des rouages rouges en bas au fond. Puis fixe la chaîne en dessous.
- E** Pasa la cadena hacia abajo a través de la parte superior del motor y alrededor de los engranajes rojos en la parte inferior. Después conecta toda la cadena en la parte de abajo.

- D** Lass die Kette nach unten durch den Motor oben fallen und ziehe sie um das rote Getriebe unten. Verbinde die Enden der Kette an der Unterseite.
- NL** Laat de ketting zakken doorheen de motor bovenaan en zo naar beneden rond de rode tandwielen onderaan. Maak de kettinguiteinden dan aan mekaar vast onderaan.
- I** Far scivolare la catena attraverso il motore dalla parte superiore e quindi giù attorno alla ruota dentata rossa sul fondo. Poi attaccare le due estremità della catena sul lato interno.
- P** Deixa tombar a Corrente através do Motor no topo e para baixo em redor das Engrenagens vermelhas situadas na base. Em seguida une a Corrente em conjunto na parte de baixo.

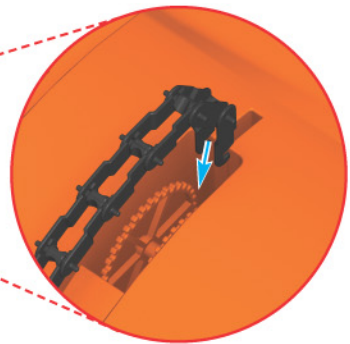
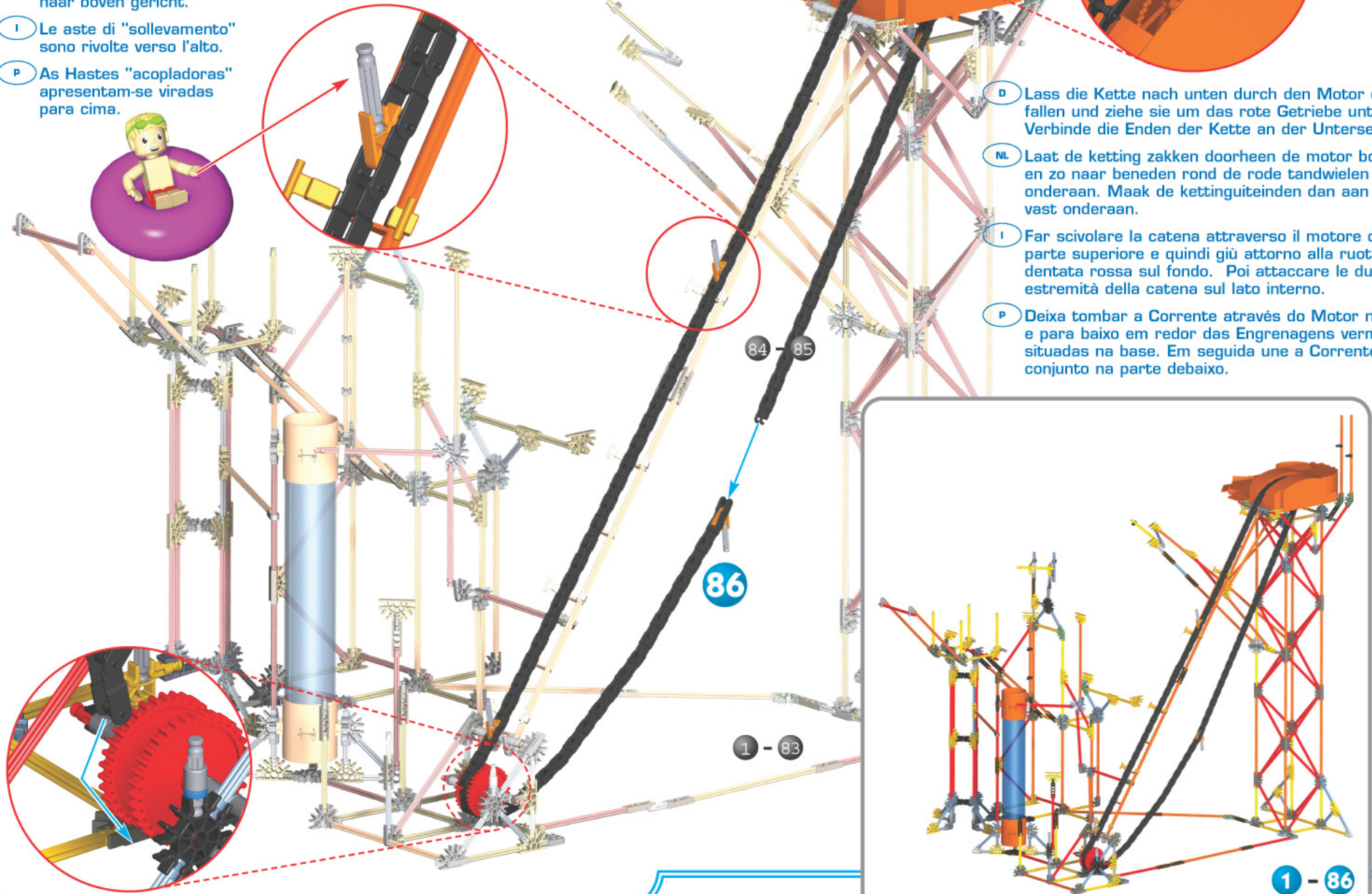

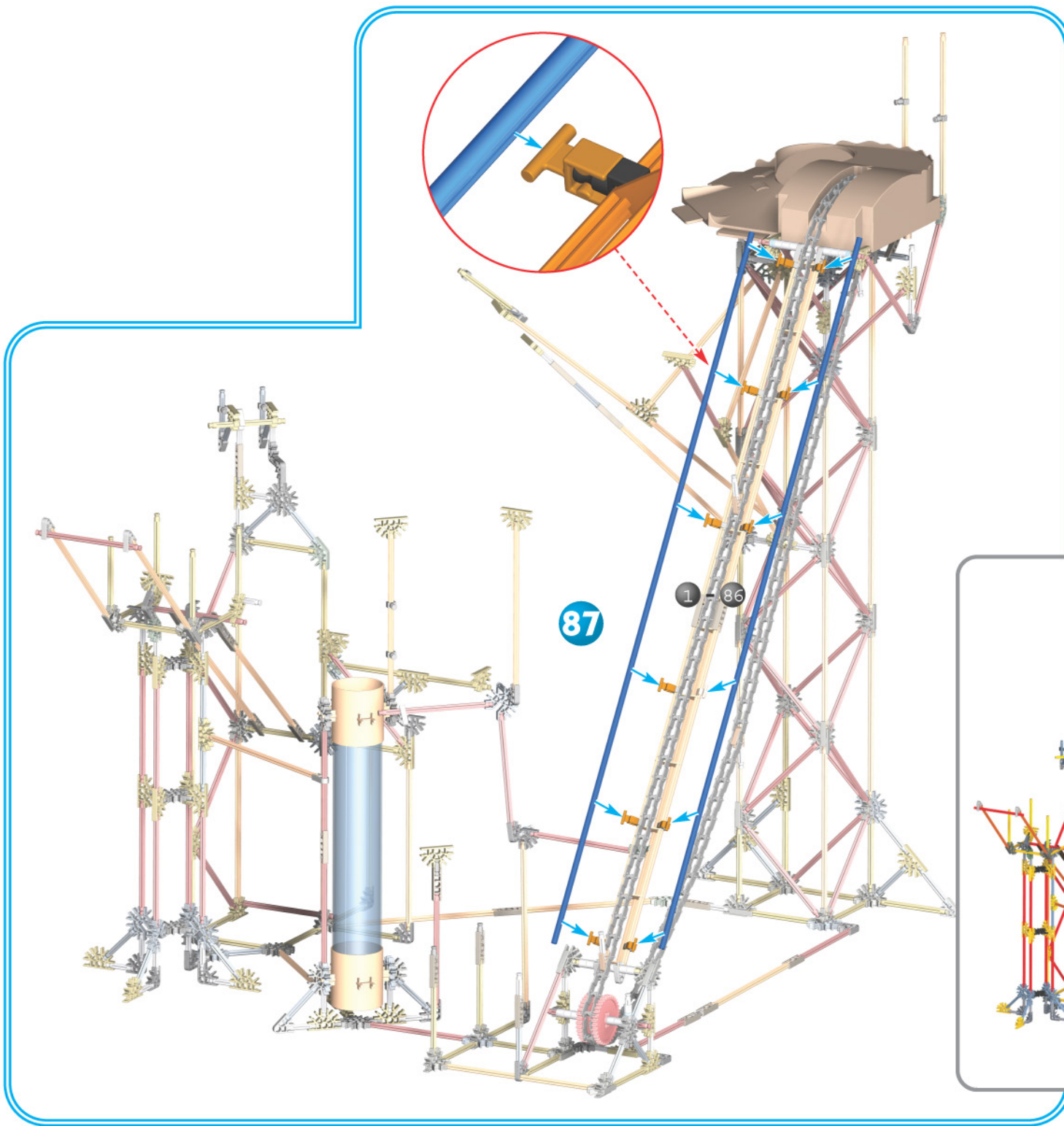

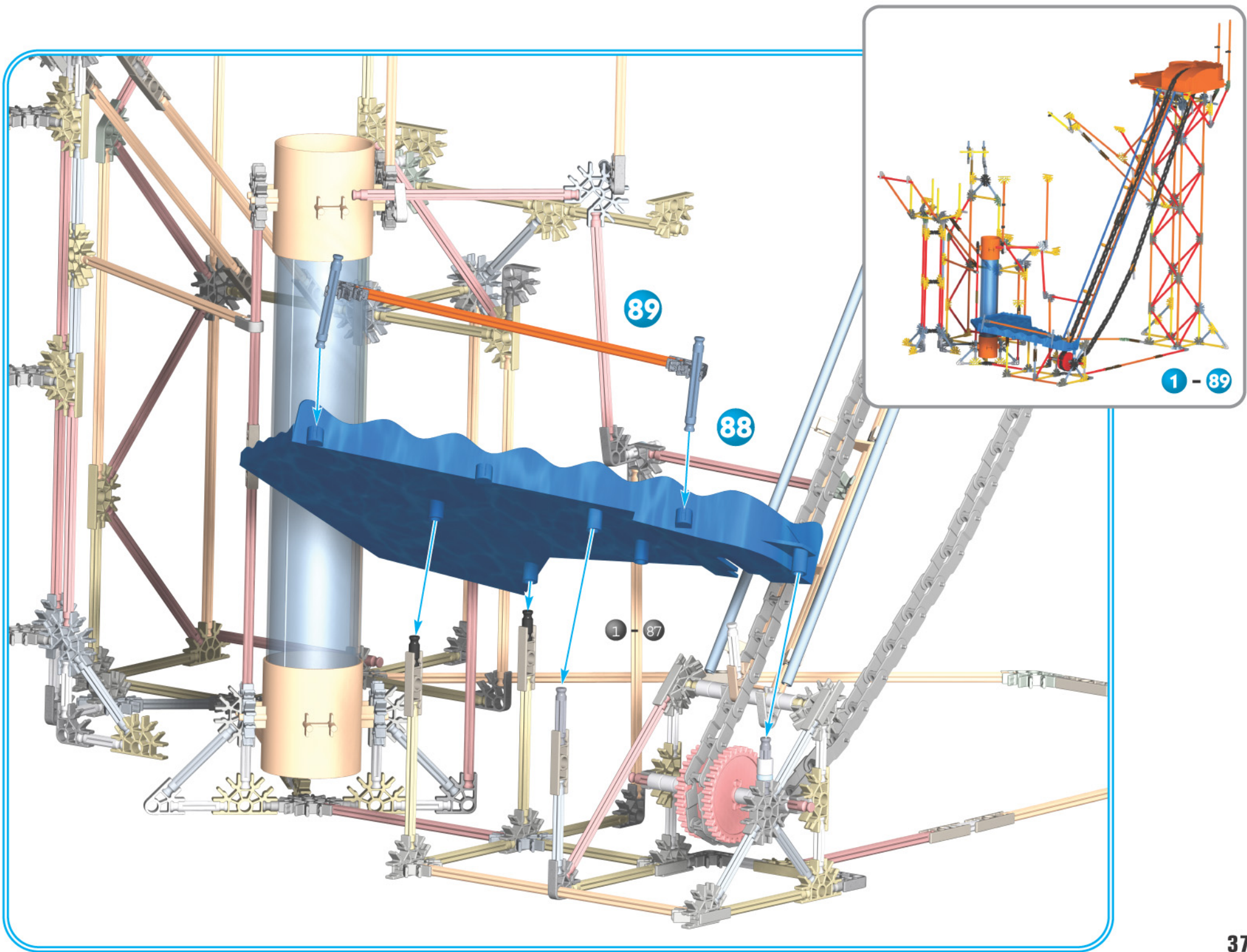

ENG Top View

F Vue du haut

E Vista de la parte superior

D Ansicht von oben

NL Bovenzicht

I Vista dall'alto

P Vista de cima

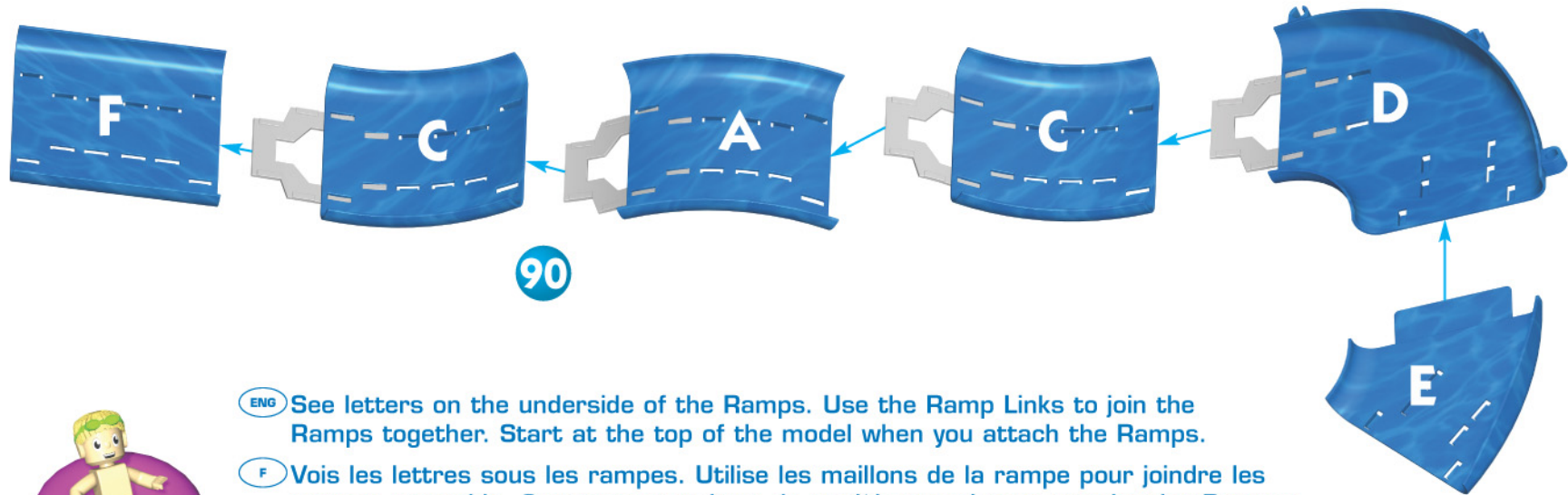

ENG See letters on the underside of the Ramps. Use the Ramp Links to join the Ramps together. Start at the top of the model when you attach the Ramps.

F Vois les lettres sous les rampes. Utilisez les maillons de la rampe pour joindre les rampes ensemble. Commencez en haut du modèle quand vous attachez les Rampes.

E Mira las letras en la parte de abajo de las rampas. Usa los eslabones de las rampas para juntar las rampas. Empiece a la cabeza del modelo cuando usted conecta las Rampas.

D Richte dich nach den Buchstaben unter den Rampen. Mit den Rampenverbindungsstücken werden die Rampen zusammengebaut. Fangen Sie oben auf dem Modell an wenn Sie, die Rampen zu befestigen.

NL Kijk naar de letters onderaan de hellingen. Gebruik de helling links om de hellingen samen te brengen. Begint u aan het hoofd van het model wanneer u de Hellingen bevestigt. Bevestigt u aan het hoofd van het model.

I Vedere le lettere sotto le rampe. Usare le connessioni delle rampe per mettere insieme le rampe. Cominciare in cima al modello quando lei attacca le Rampe.

P Observa as letras na parte inferior das Rampas. Usa os Elos de União das Rampas para juntares as Rampas em conjunto. Comece no topo do modelo quando une as Rampas.

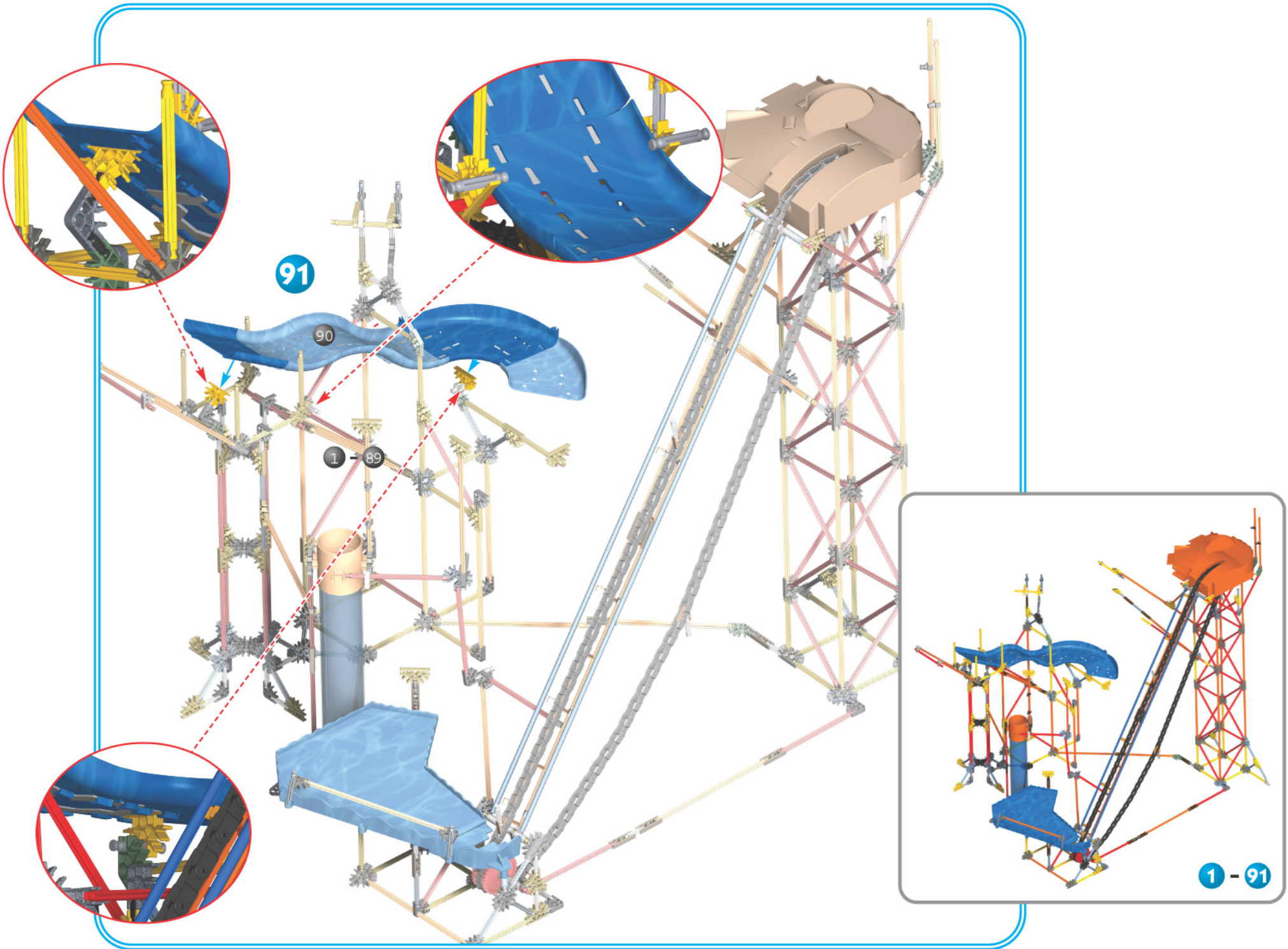



92

ENG This Yellow Connector does NOT connect to the Ramp.

F Ce connecteur jaune NE se connecte PAS à la rampe.

E Este conector amarillo NO se conecta con la rampa.

D Dieses gelbe Verbindungsstück wird NICHT mit der Rampe verbunden.

NL Dit geel verbindingsstuk wordt NIET vastgemaakt aan de helling.

I Questo connettore giallo NON si collega alla rampa.

P Este Conector vermelho NÃO se liga à Rampa.

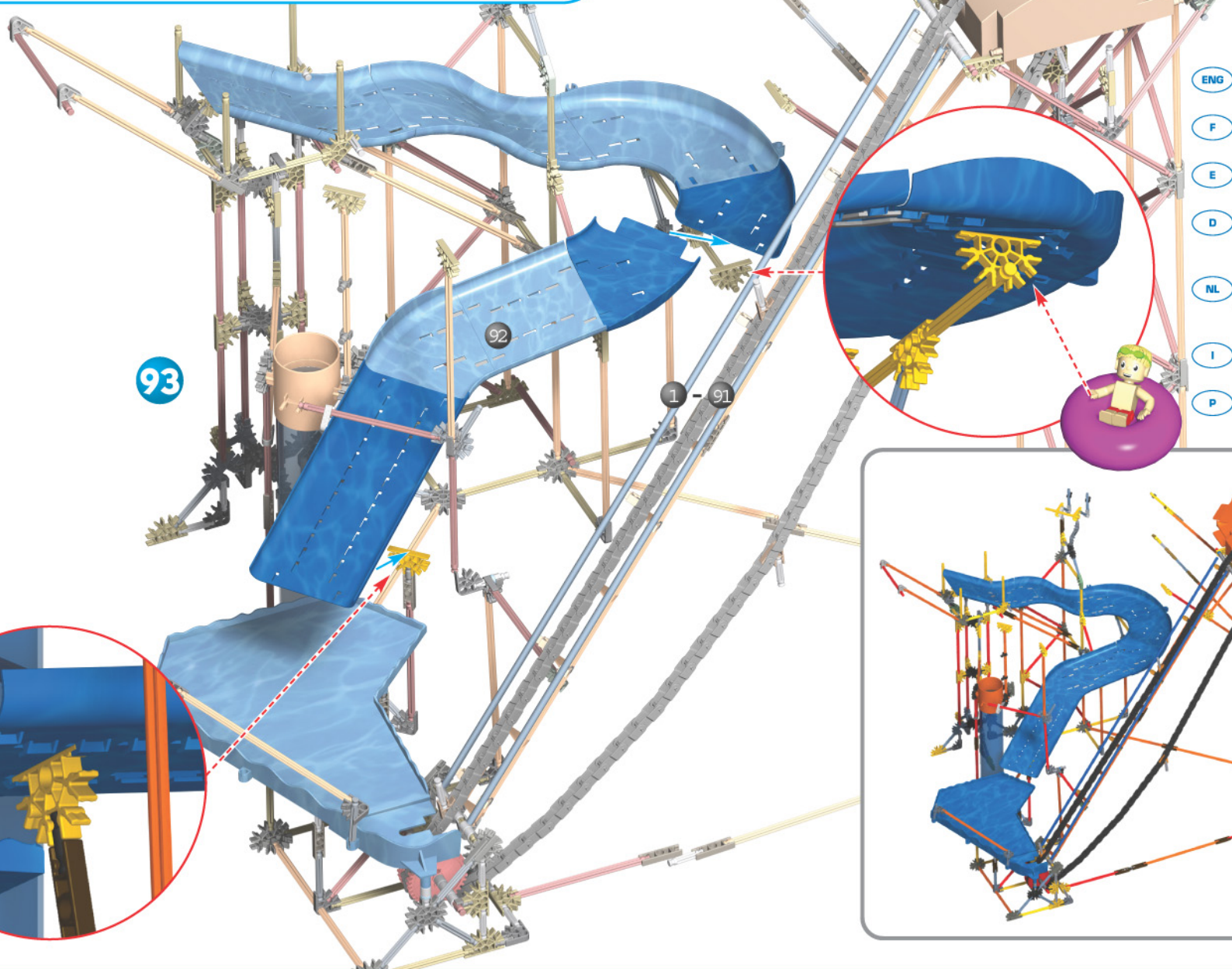

93

1 - 91



1 - 93

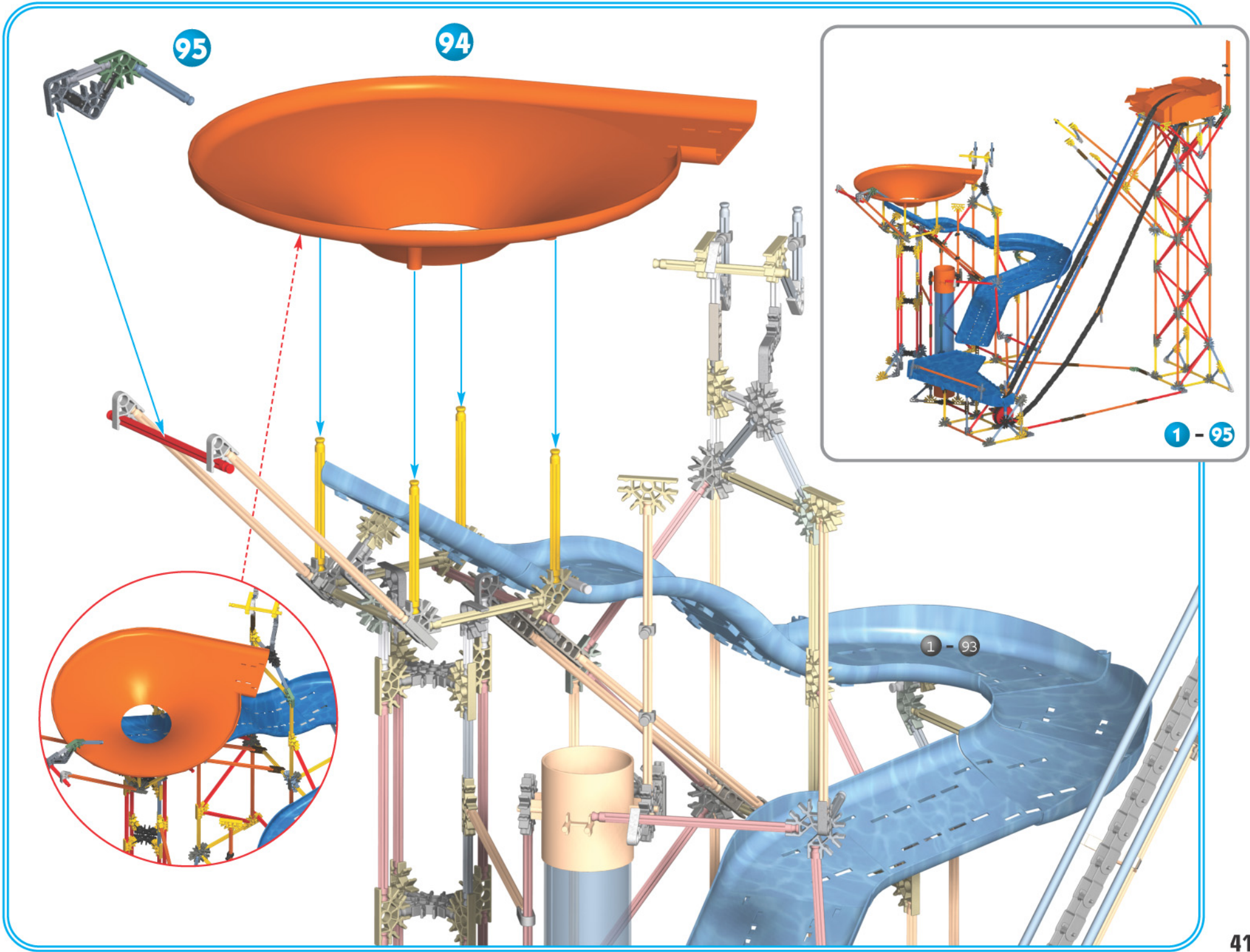

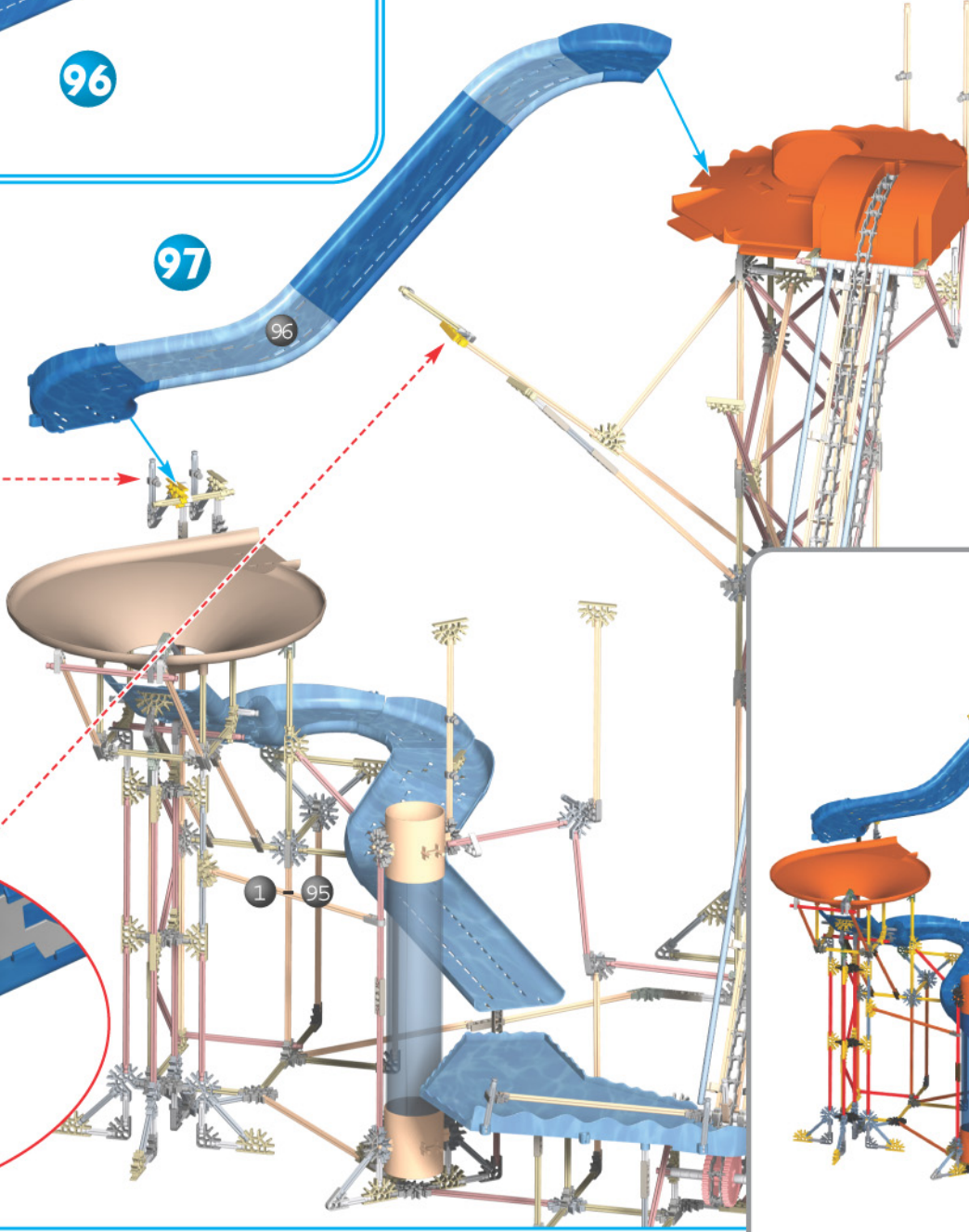
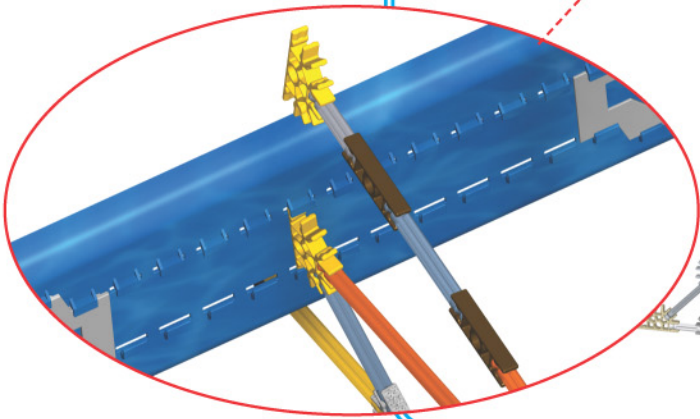
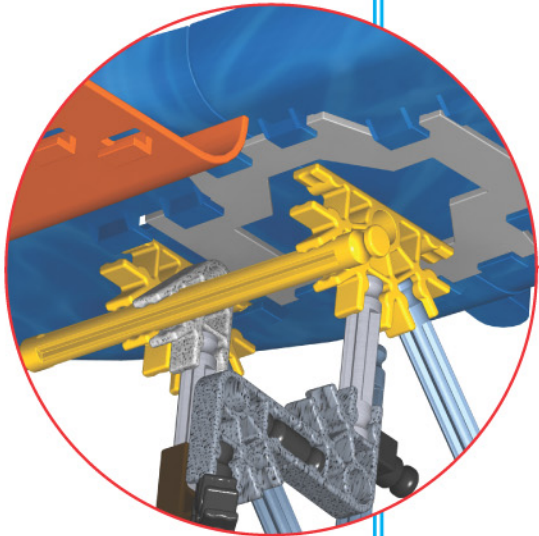
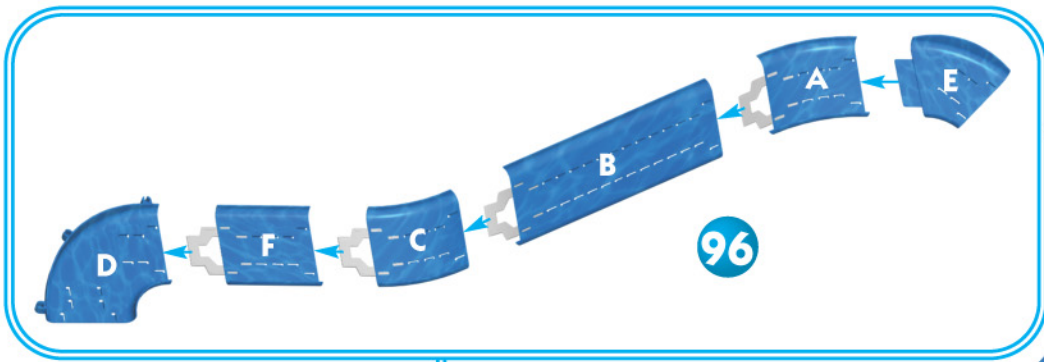

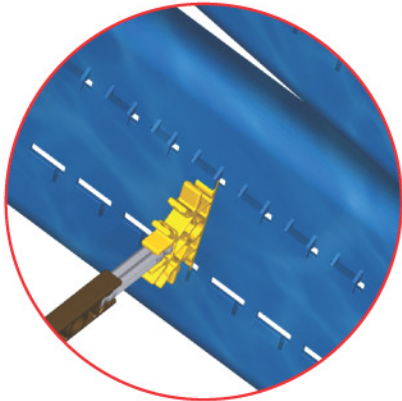
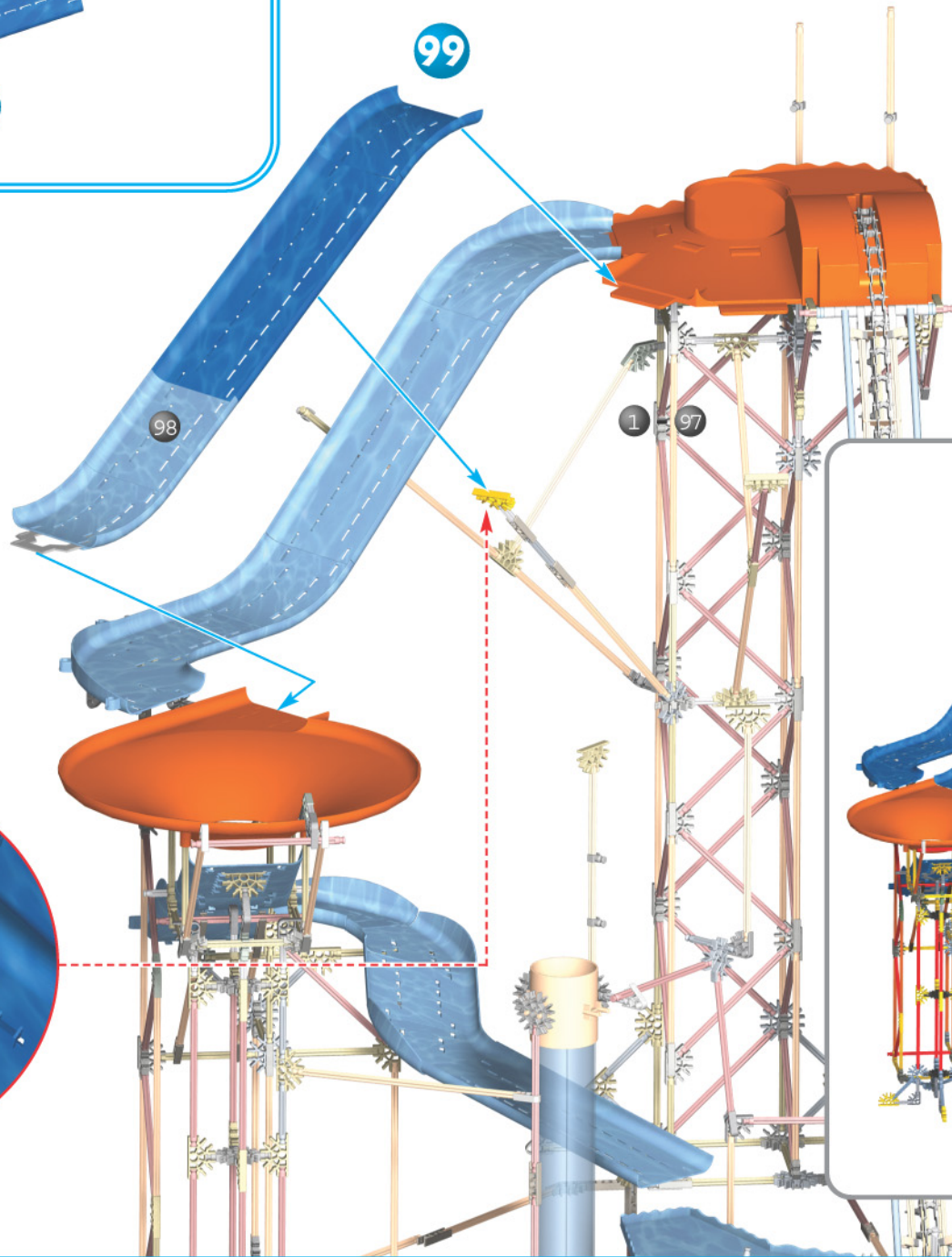
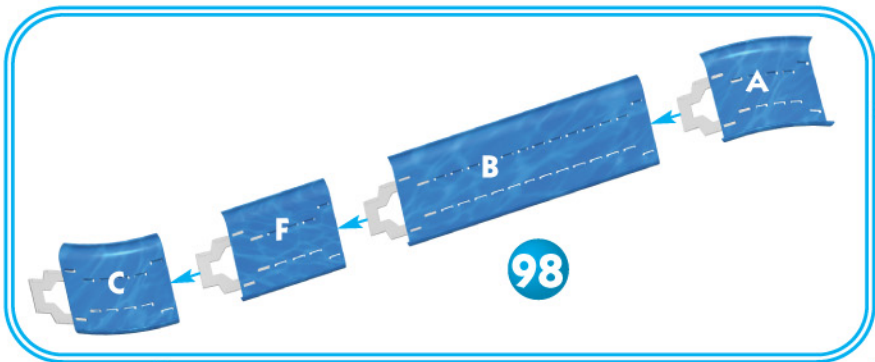

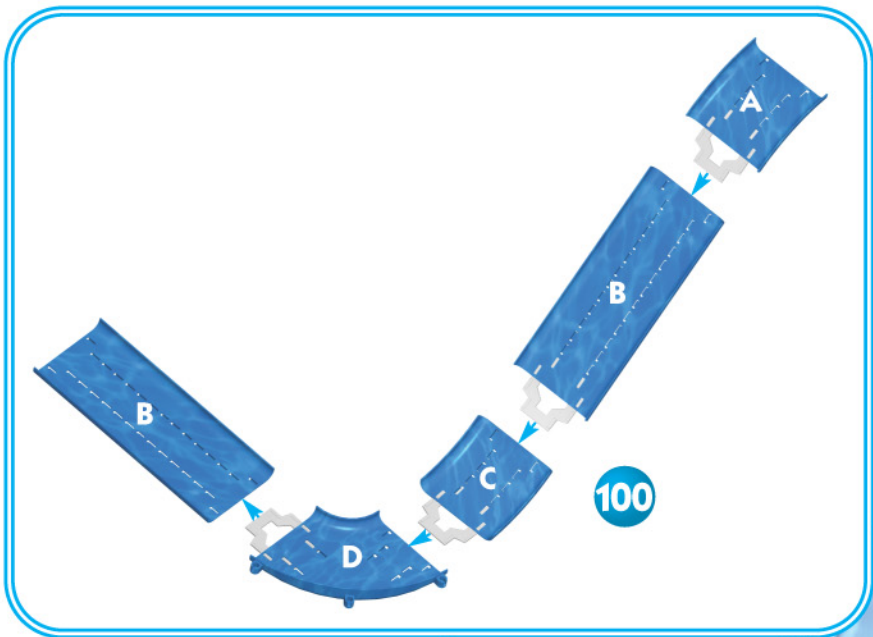

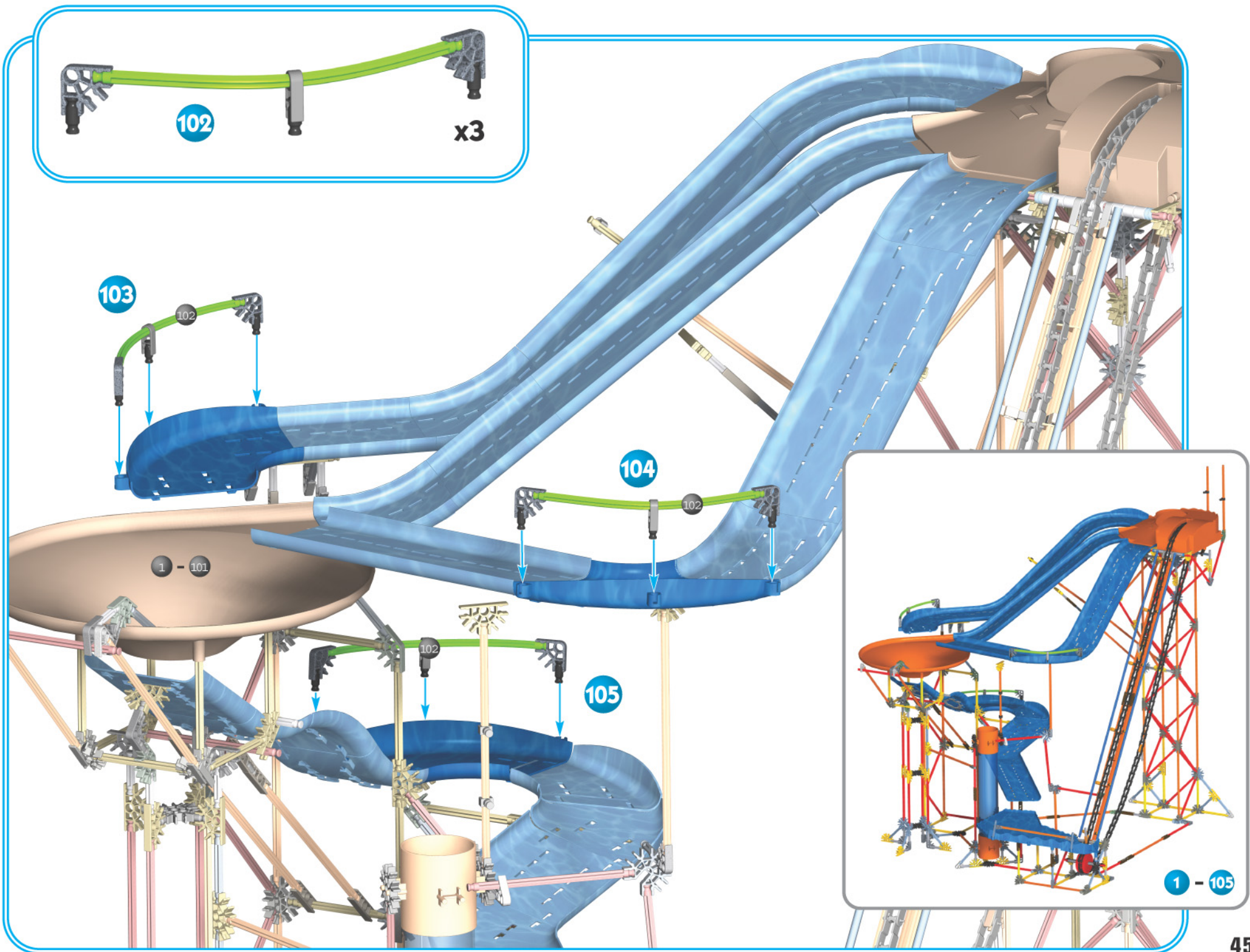

102

x3

103

104

105

1 - 105

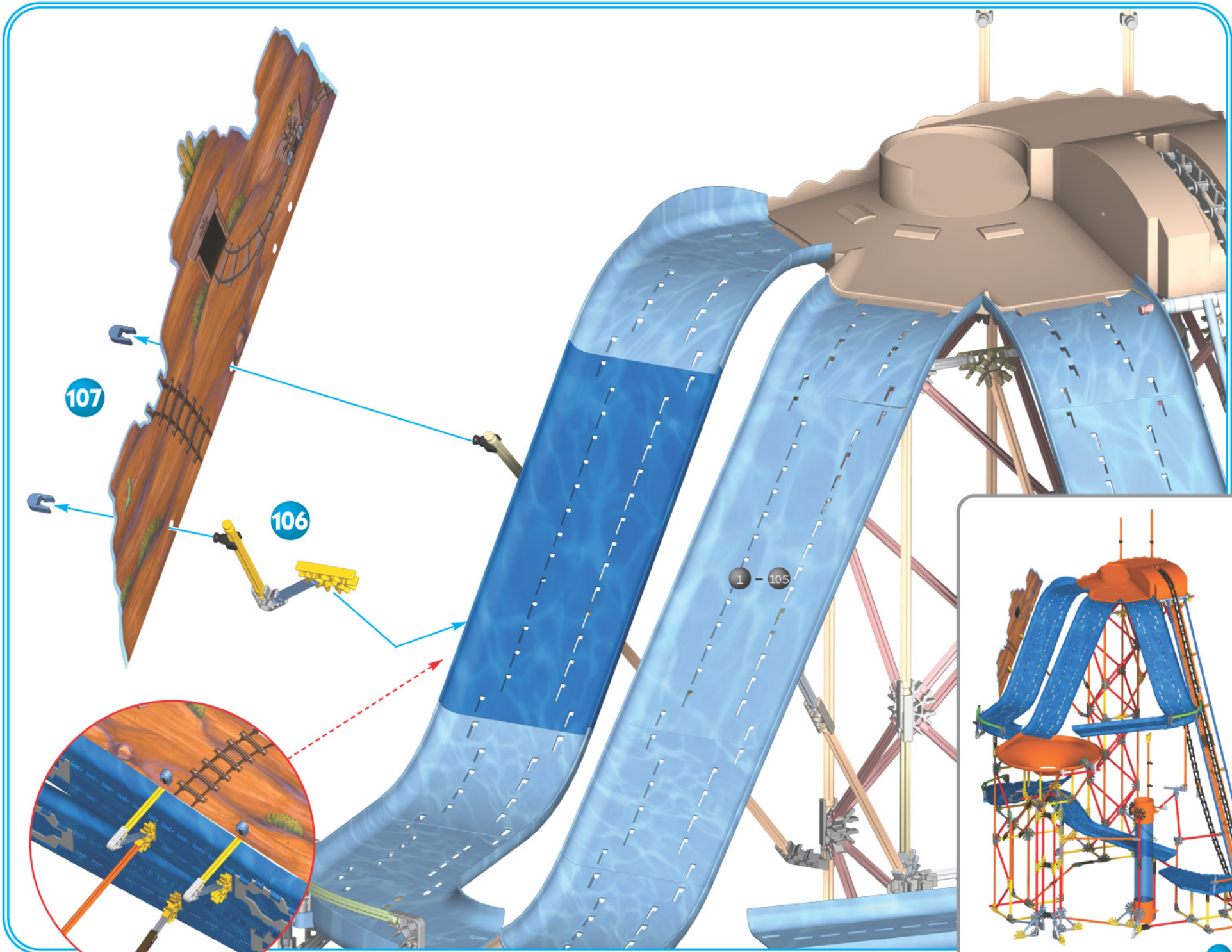

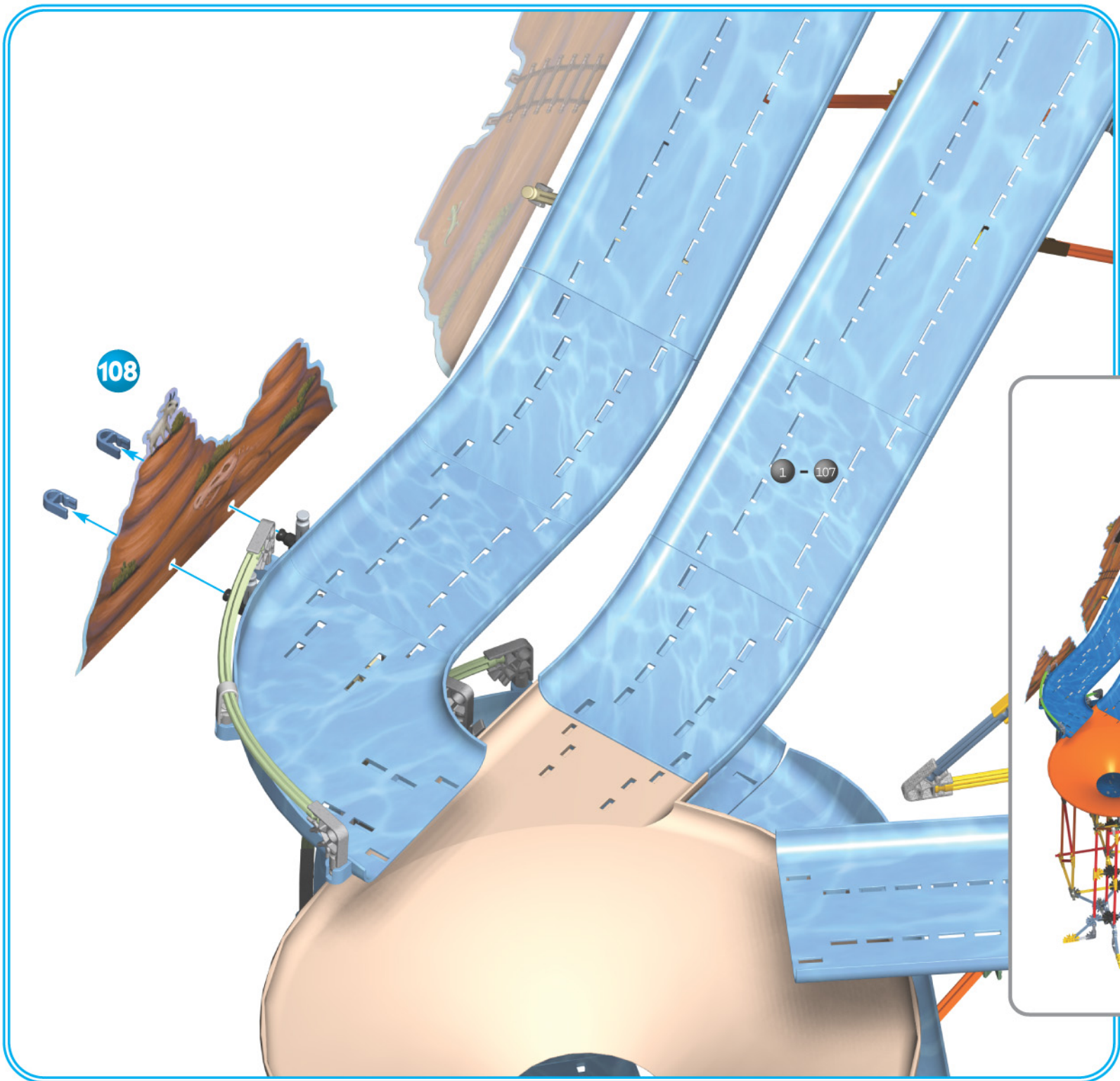

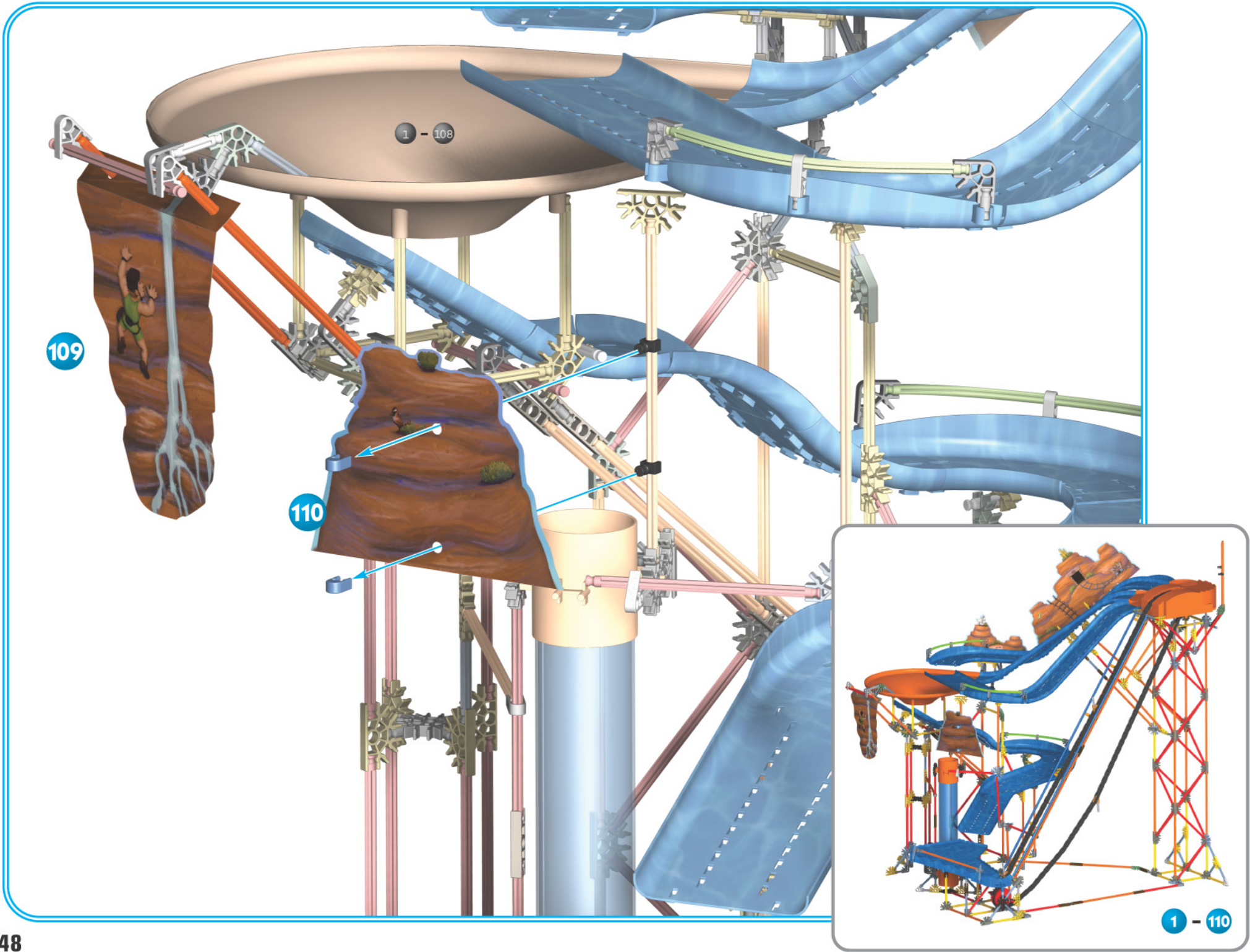

111

CORKSCREW  
CANYON

1 - 110



# CORKSCREW CANYON

## ALTERNATE BUILD

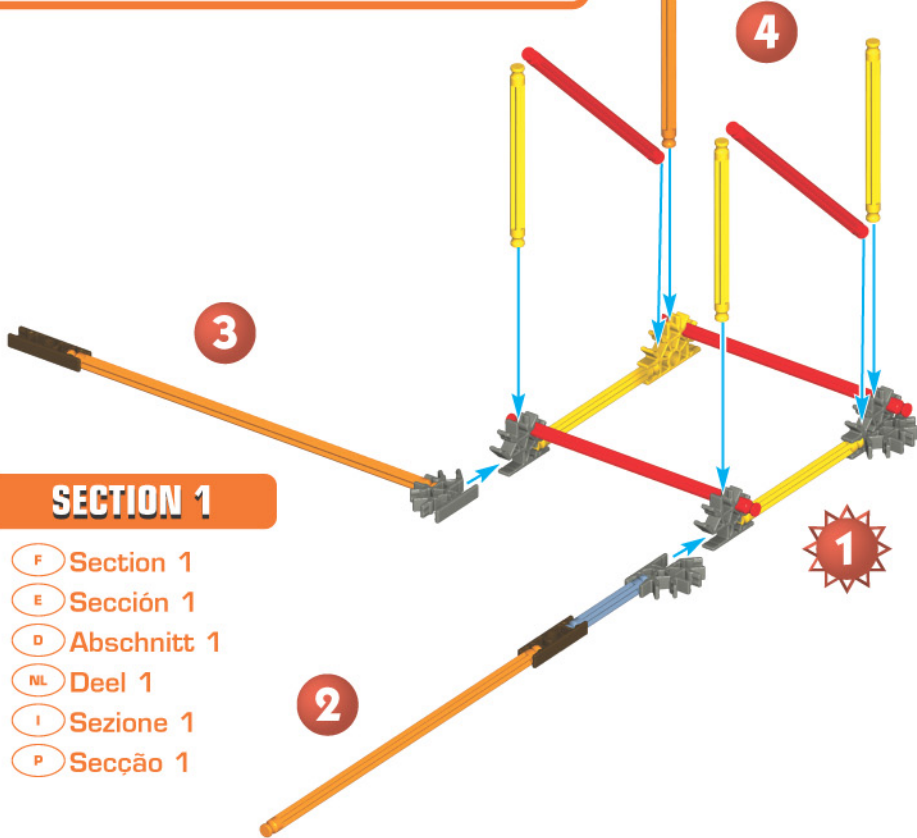

### SECTION 1

- (F) Section 1
- (E) Sección 1
- (D) Abschnitt 1
- (NL) Deel 1
- (I) Sezione 1
- (P) Secção 1

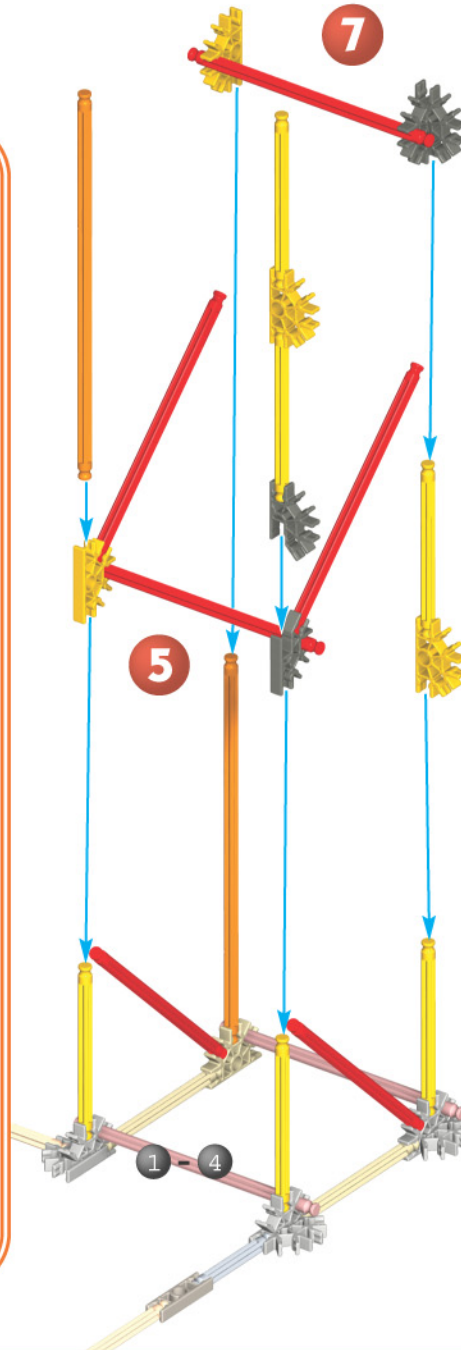

- (ENG) Be sure to orient all Connectors correctly.
- (F) Veillez à orienter correctement tous les connecteurs.
- (E) Asegúrate de orientar todos los conectores correctamente.
- (D) Achte auf die richtige Ausrichtung der Verbindungsstücke.
- (NL) Verzeker je ervan alle koppelstukken juist af te richten.
- (I) Accertati di orientare tutte le connessioni correttamente.
- (P) Certifica-te de que orientas os Conectores correctamente.

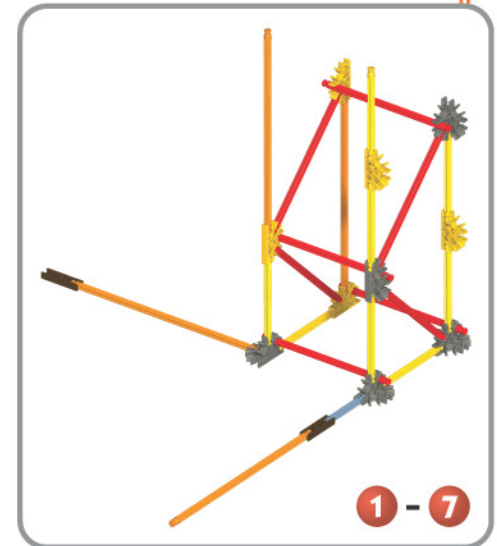

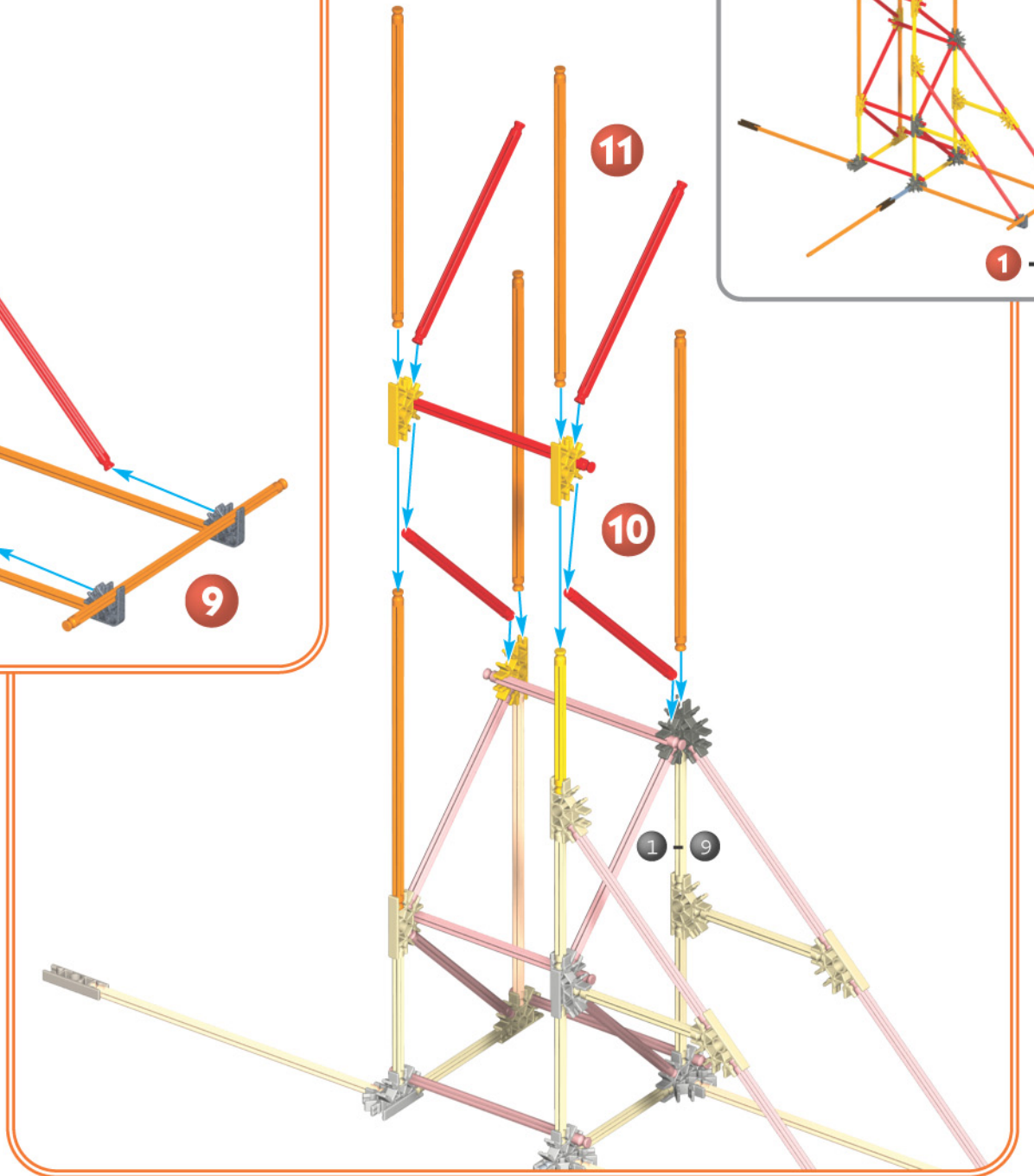
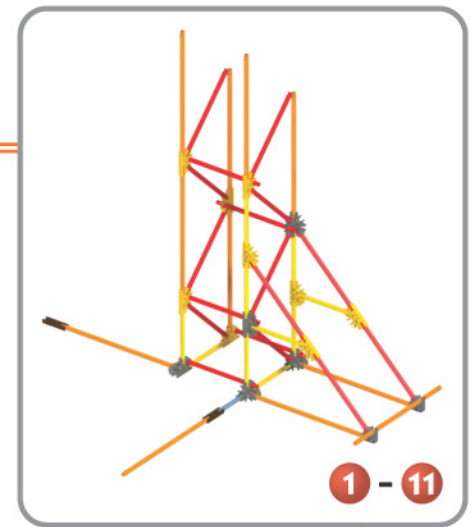
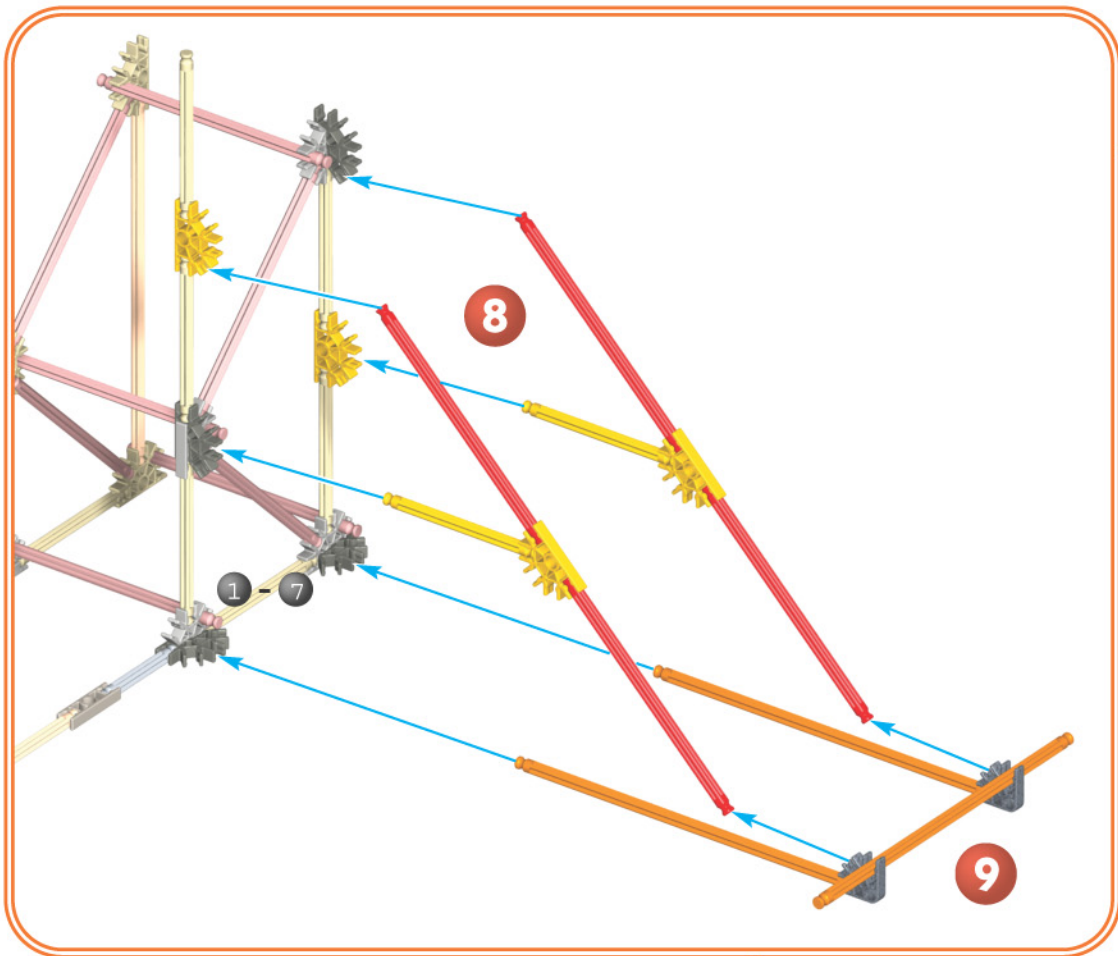



13



12

- ENG This (section) may hang down but will be used when attaching the Ramps.
- F Cette (section) peut pendre mais sera utilisée au moment de fixer les rampes.
- E Esta (section) puede quedar colgando, pero se usará cuando se sujeten las rampas.
- D Dieser Abschnitt hängt evtl. frei, er wird aber benutzt, wenn die Rampen befestigt werden.
- NL Dit (section) kan naar beneden hangen maar zal gebruikt worden voor het vastmaken van de hellingen.
- I Questa (section) potrebbe pendere ma sarà usata quando si attaccano le rampe.
- P Esta (section) pode ficar pendente, mas será utilizada quando se montarem as Rampas.

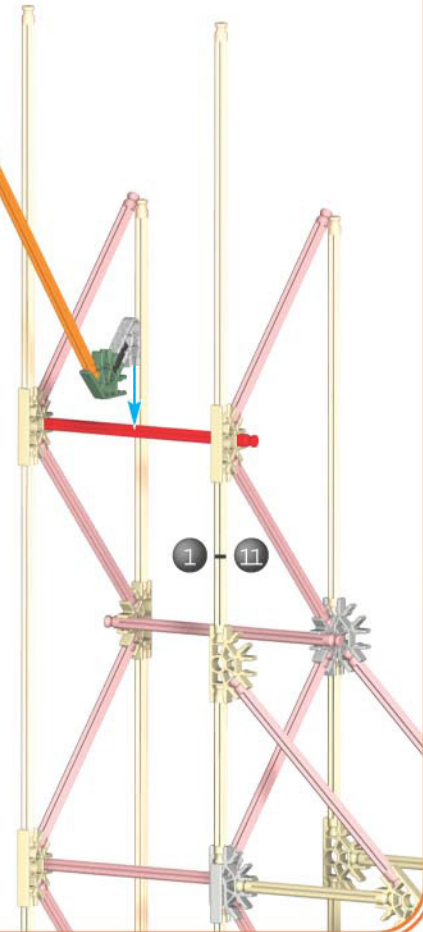

15

16

14

1 - 13

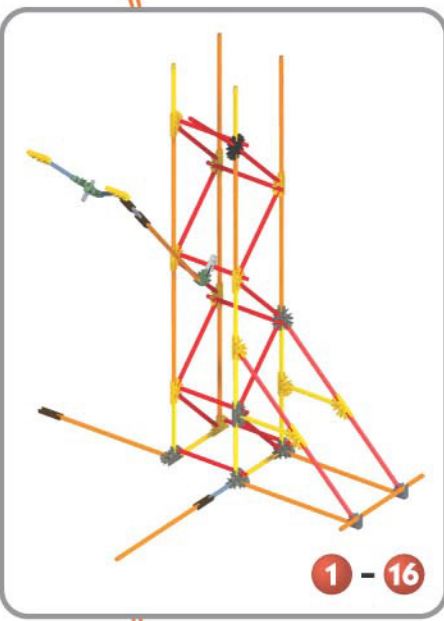
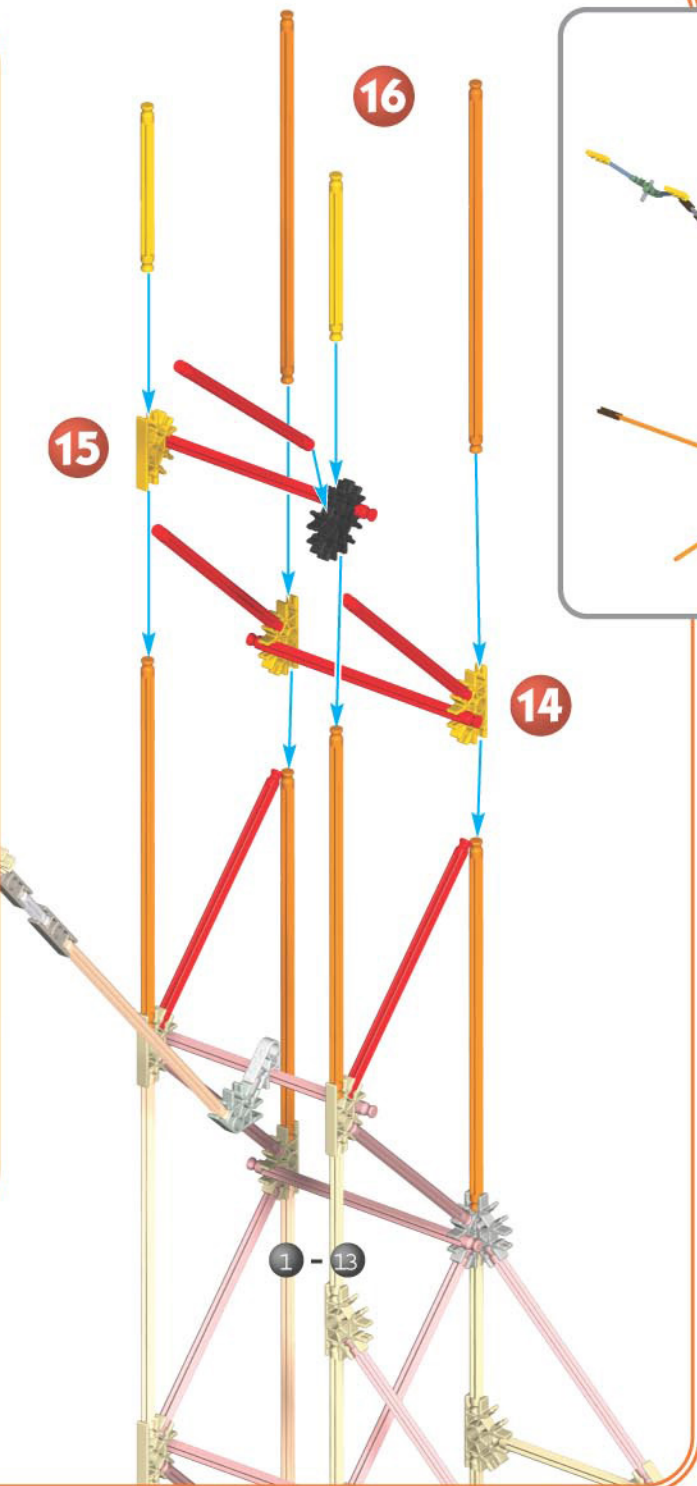

1 - 16

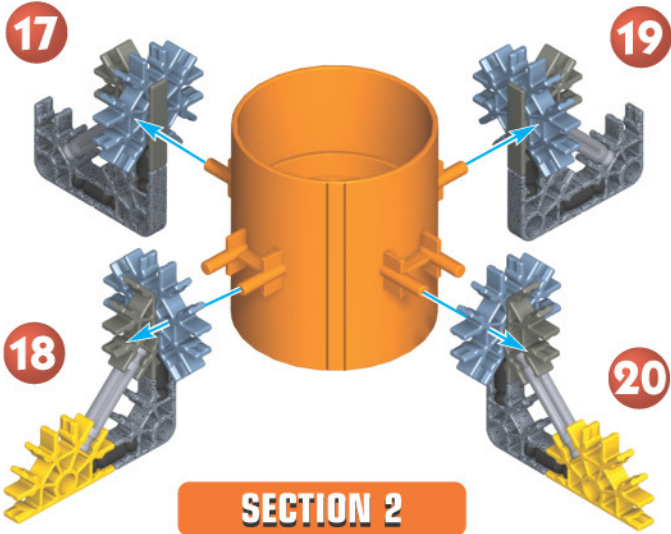

**SECTION 2**

- F Section 2
- E Sección 2
- D Abschnitt 2
- NL Deel 2
- I Sezione 2
- P Secção 2

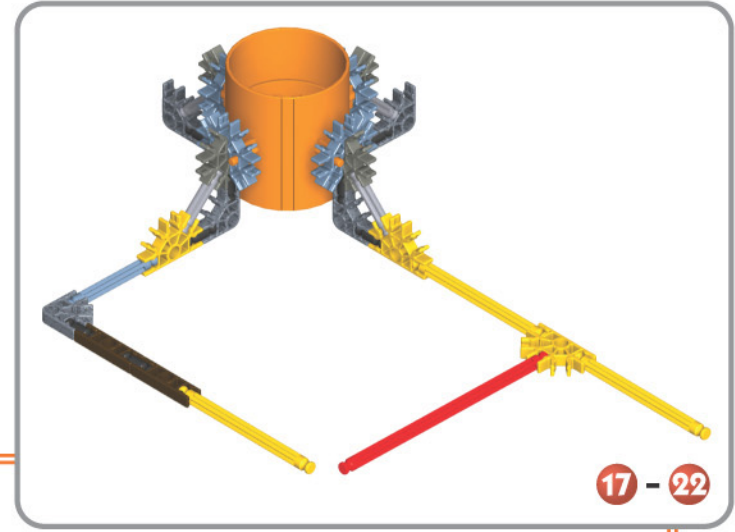

17 - 22

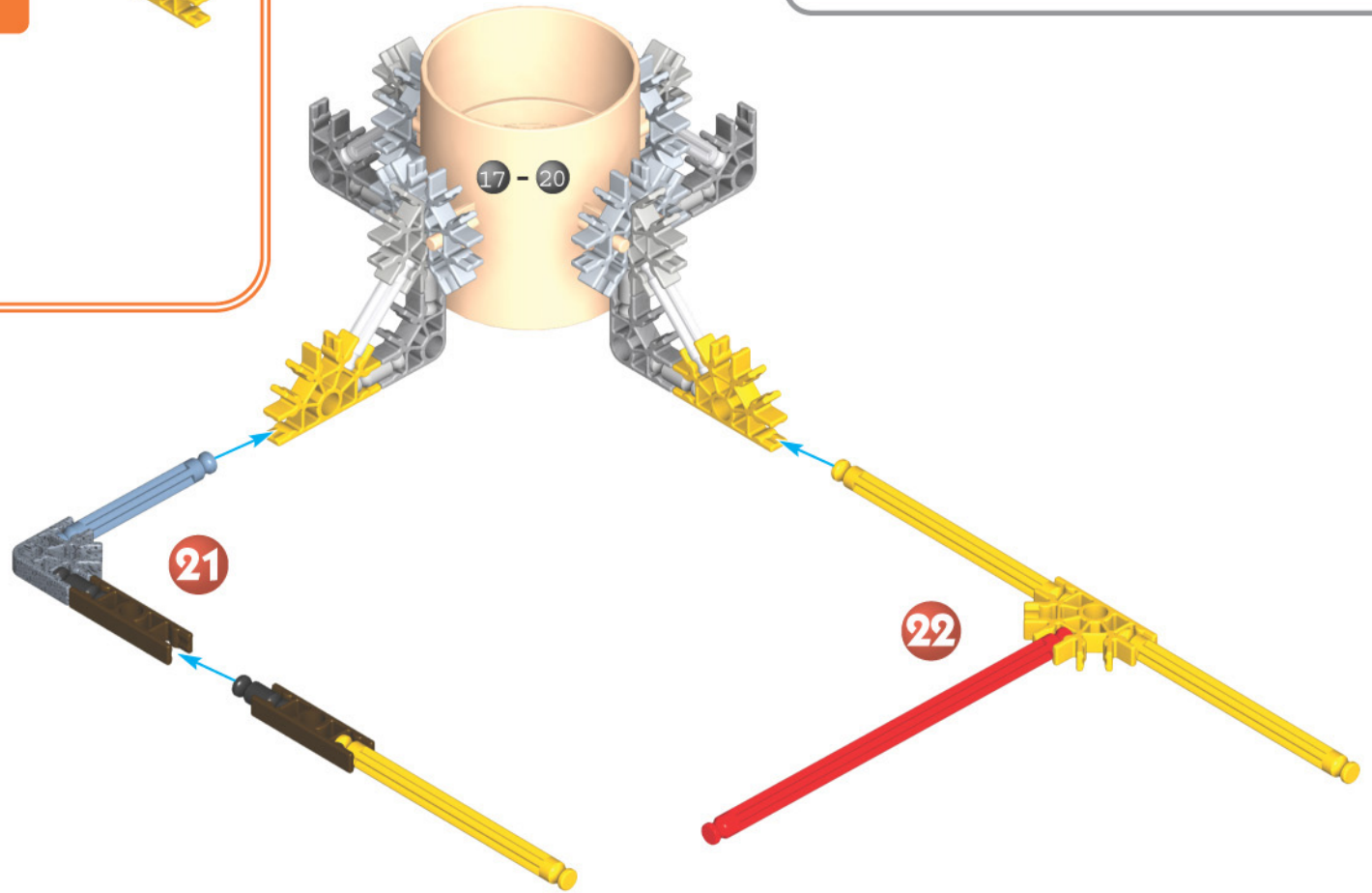

17 - 20

21

22

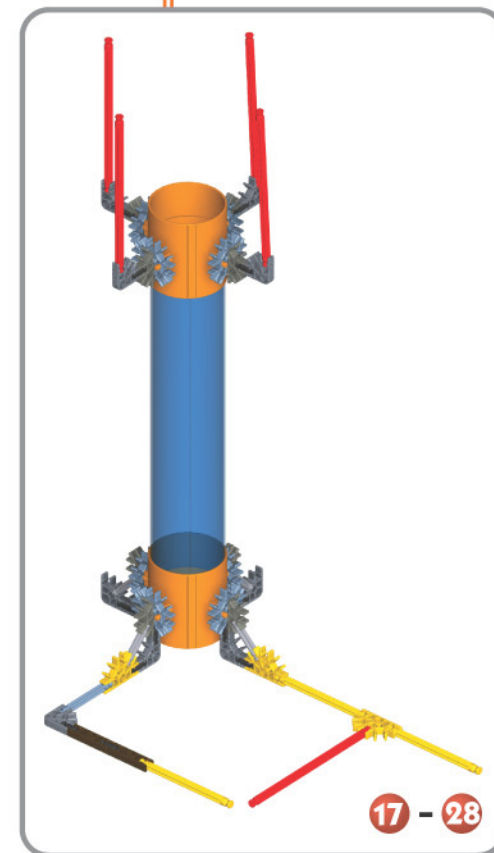
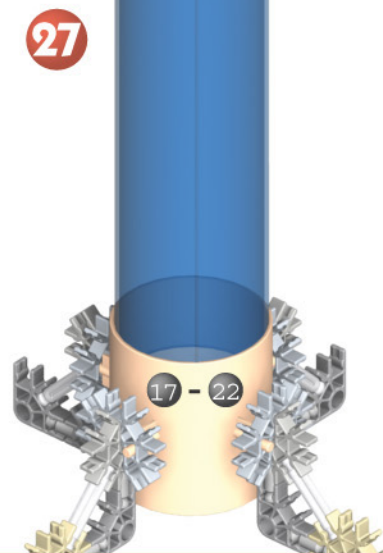
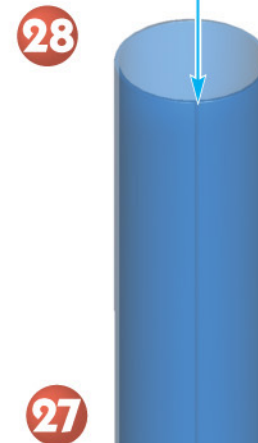
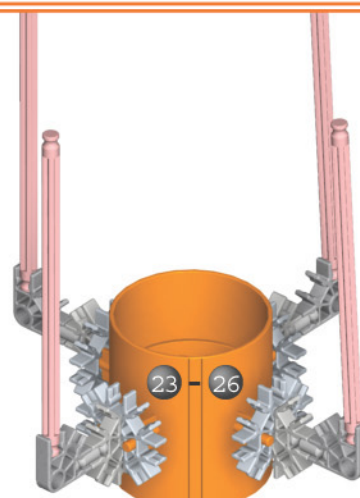
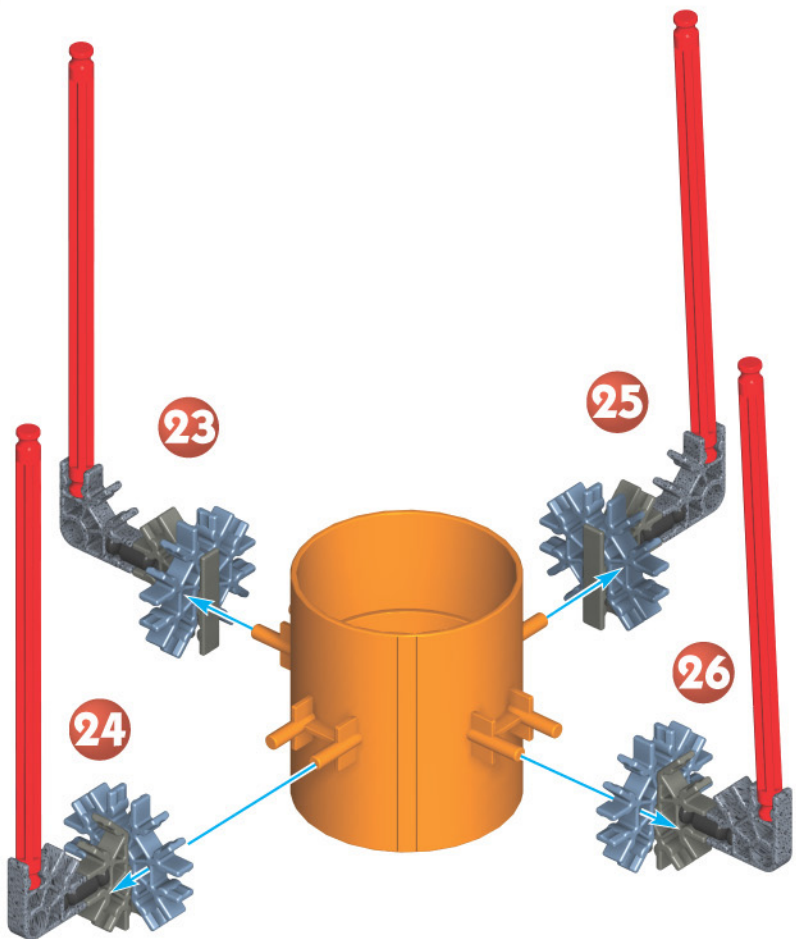

**ENG** Line up grooves on blue Tube and Holder, then push together tightly.

**F** Aligner les rainures sur le tuyau bleu et l'attache, puis pousse de sorte qu'ils tiennent bien ensemble.

**E** Alinea las muescas en el tubo azul y el soporte. Luego presiona las piezas con firmeza para que queden bien encastradas.

**D** Die Rillen auf den blauen Röhren und den Haltern müssen aufeinander ausgerichtet sein. Drücke sie fest zusammen.

**NL** Richt de groeven op het blauwe buisje en de houder op mekaar af en duw ze dan goed tezamen.

**I** Allineare i solchi sul tubo blu e il supporto, quindi premere insieme saldamente.

**P** Alinha as ranhuras no Tubo Azul e no Fixador, seguidamente, empurra firmemente umas contra as outras.

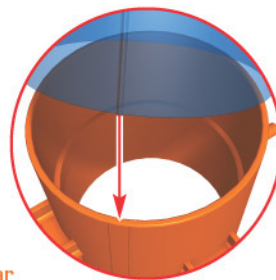

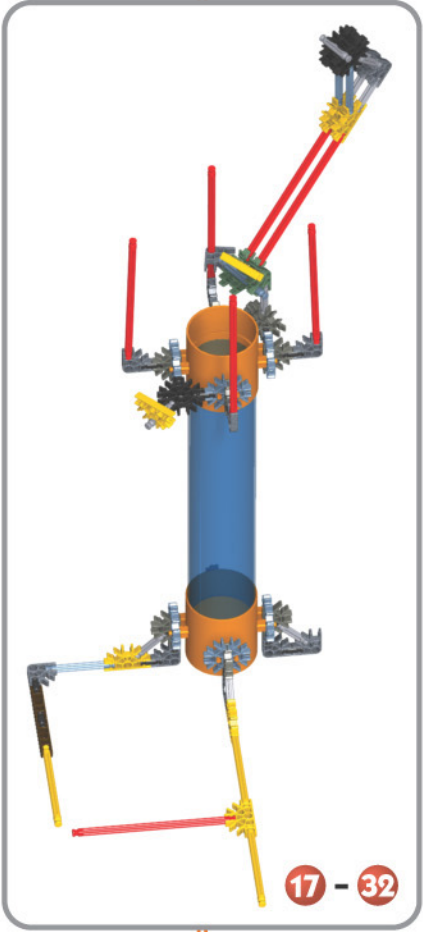
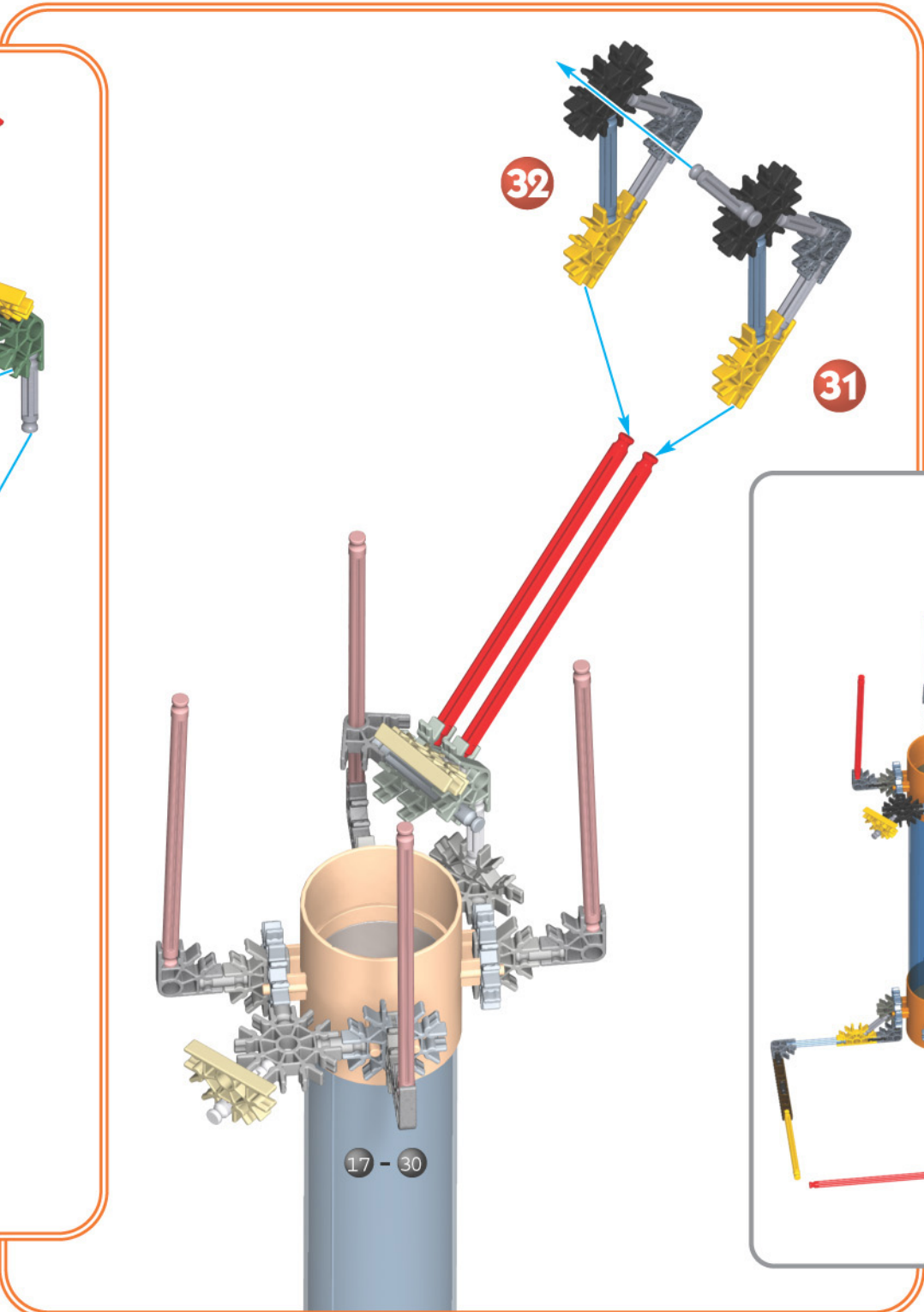
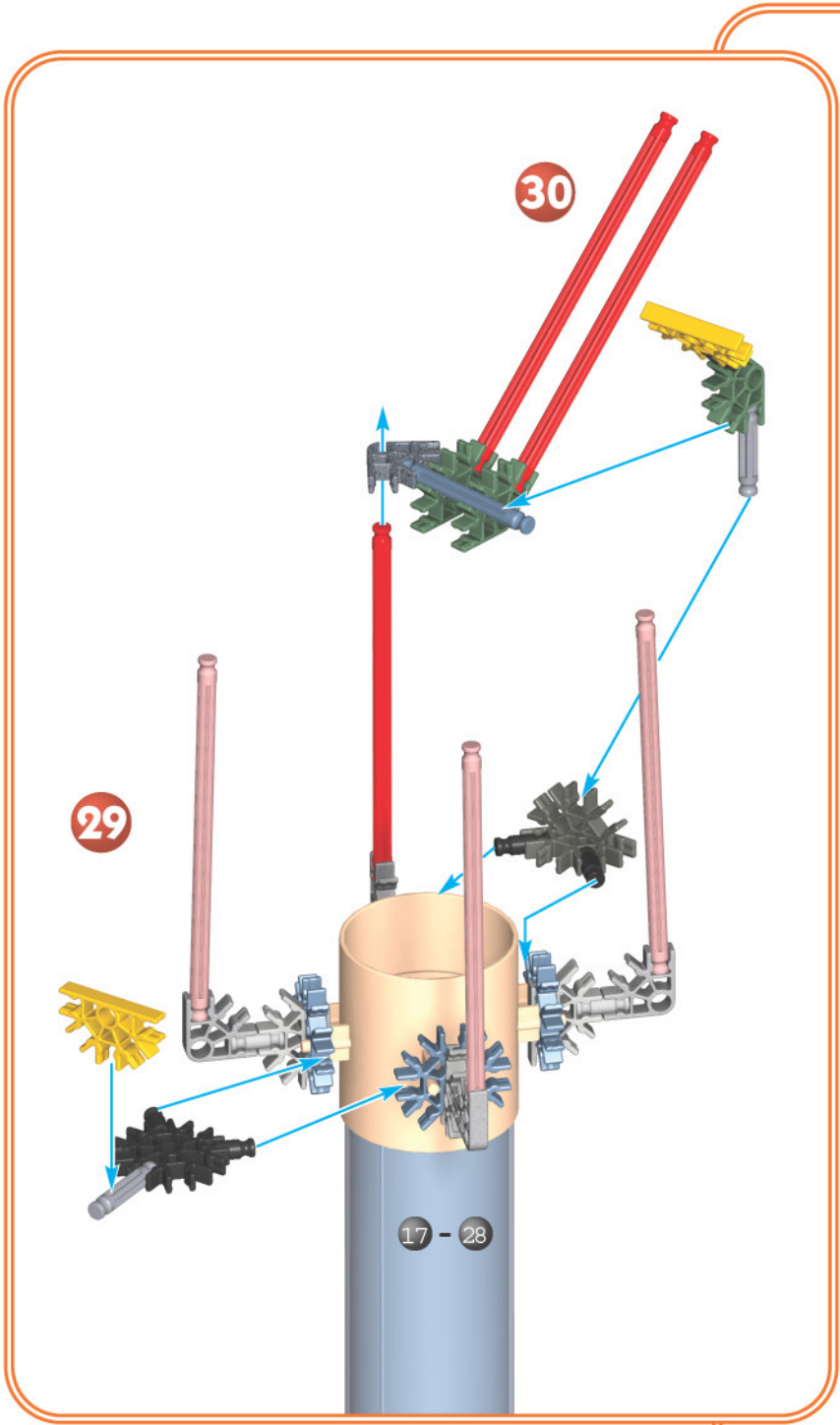



- (ENG) Join Section 1 to 2.
- (F) Joins section 1 à 2.
- (E) Junta la sección 1 con la sección 2.
- (D) Verbinde Abschnitt 1 mit Abschnitt 2.
- (NL) Maak deel 1 vast aan deel 2.
- (I) Collegare la sezione 1 alla 2.
- (P) Junta a secção 1 à secção 2.

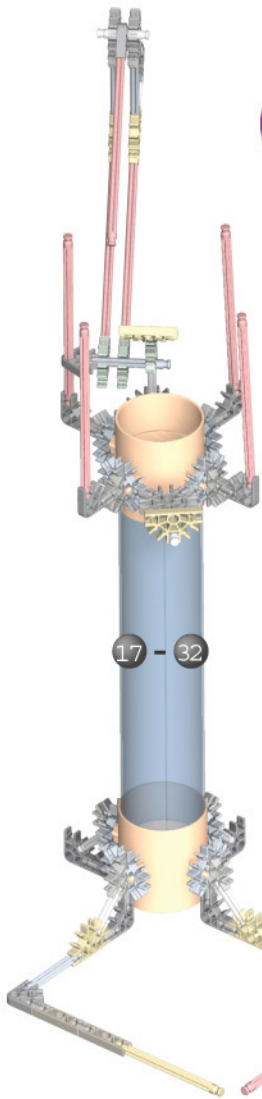

33

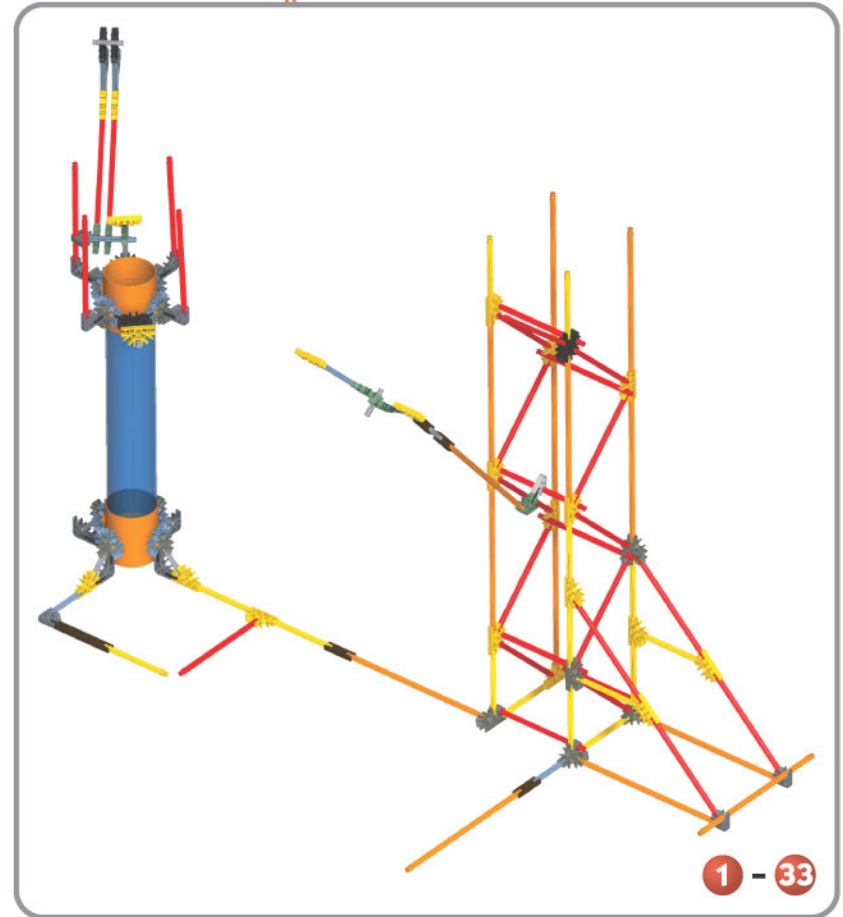
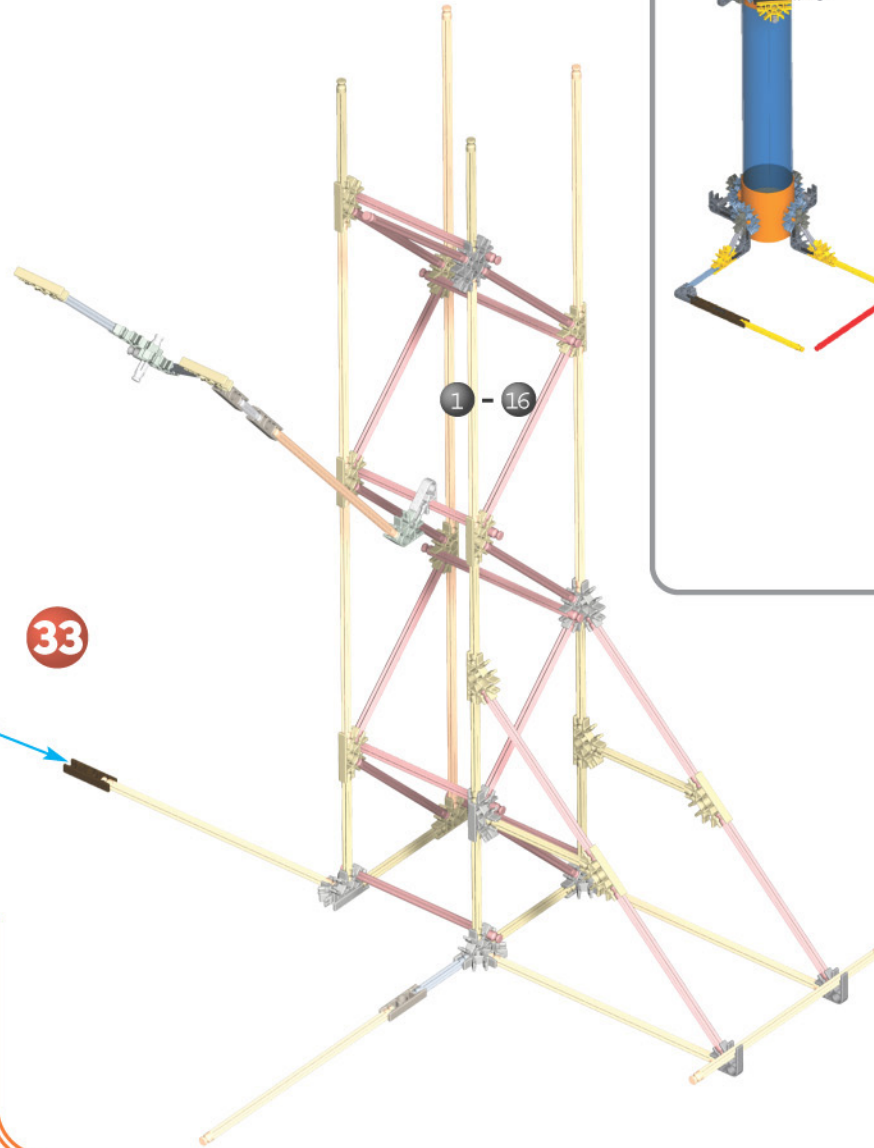

### SECTION 3

- F Section 3
- E Sección 3
- D Abschnitt 3
- ML Deel 3
- I Sezione 3
- P Secção 3

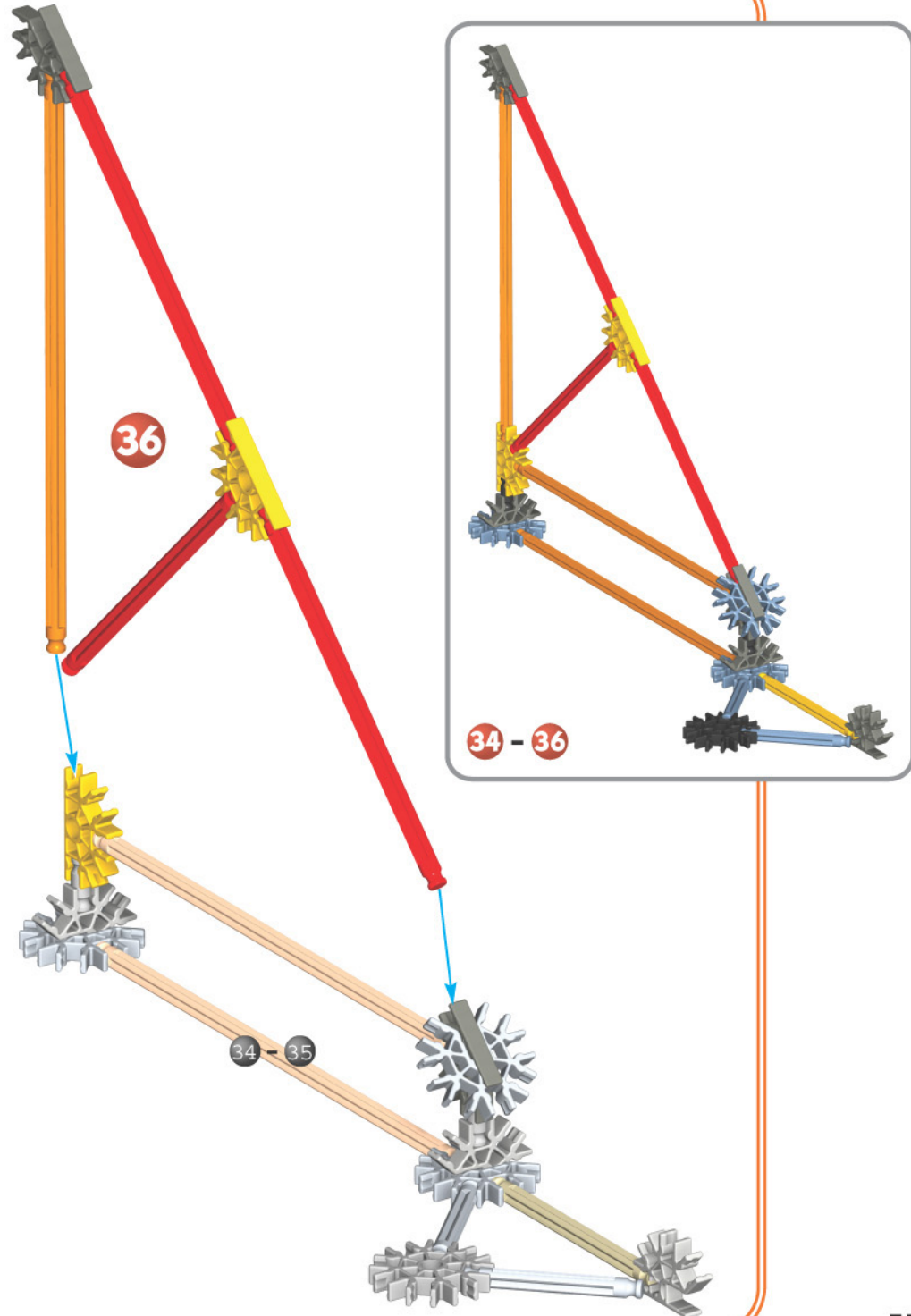
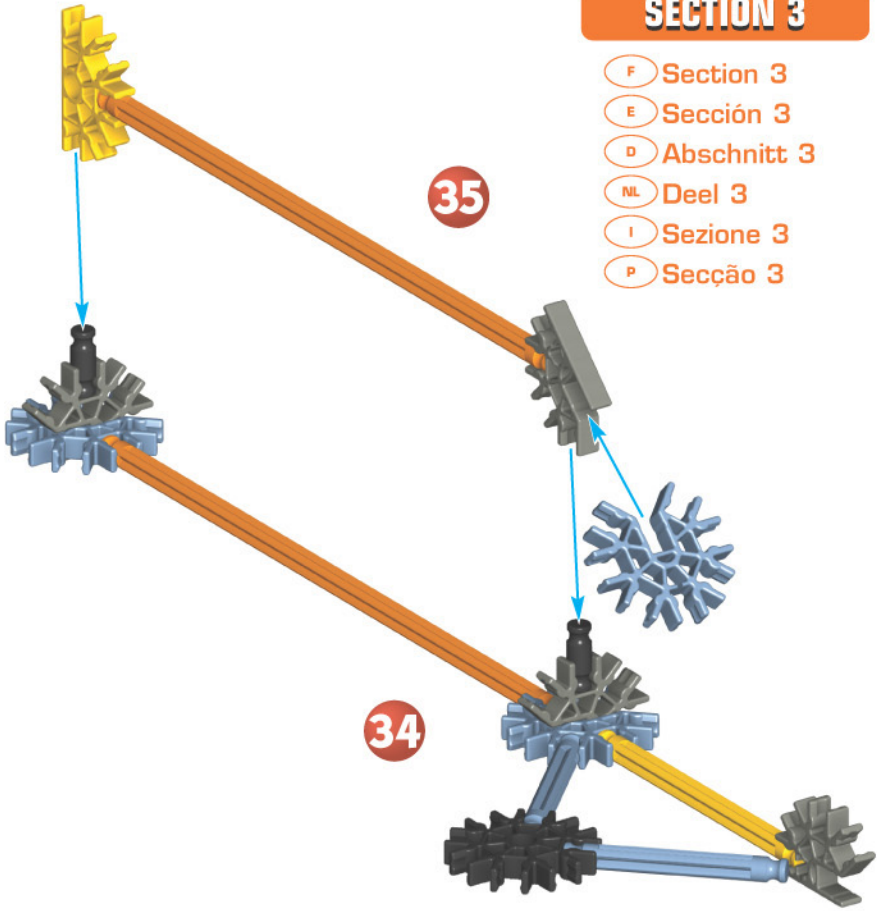

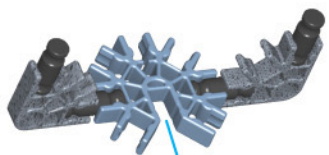

37

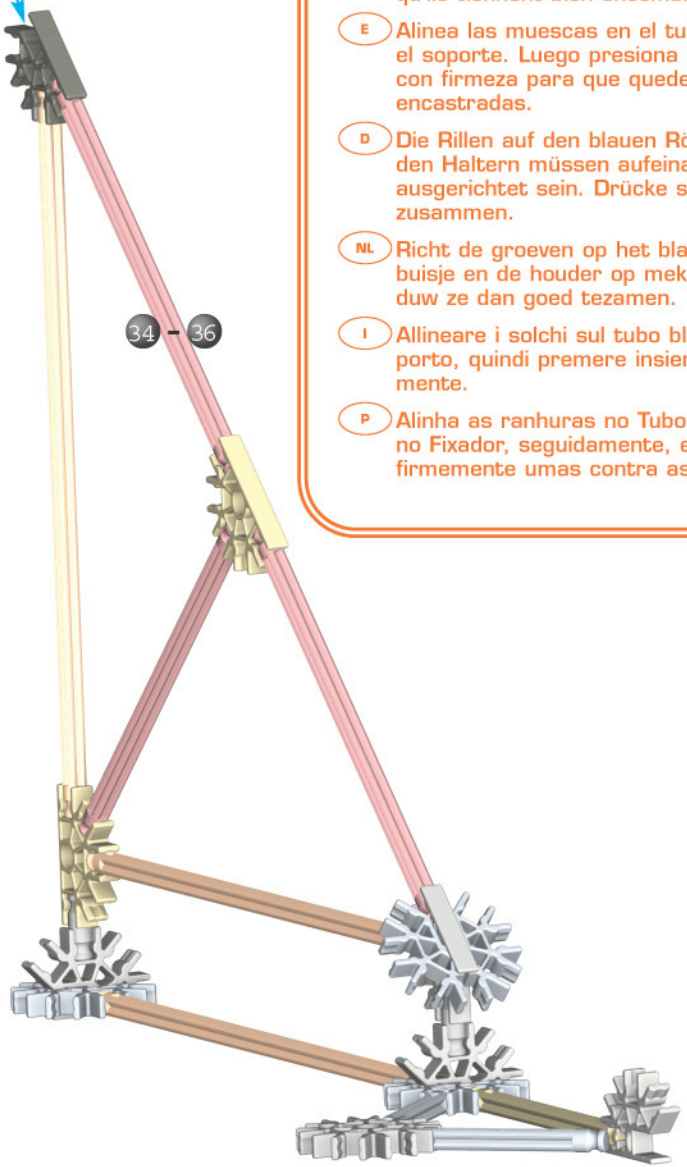

- ENG Line up grooves on blue Tube and Holder, then push together tightly.
- F Aligne les rainures sur le tuyau bleu et l'attache, puis pousse de sorte qu'ils tiennent bien ensemble.
- E Alinea las muescas en el tubo azul y el soporte. Luego presiona las piezas con firmeza para que queden bien encastradas.
- D Die Rillen auf den blauen Röhren und den Haltern müssen aufeinander ausgerichtet sein. Drücke sie fest zusammen.
- NL Richt de groeven op het blauwe buisje en de houder op mekaar af en duw ze dan goed tezamen.
- I Allineare i solchi sul tubo blu e il supporto, quindi premere insieme saldamente.
- P Alinha as ranhuras no Tubo Azul e no Fixador, seguidamente, empurra firmemente umas contra as outras.

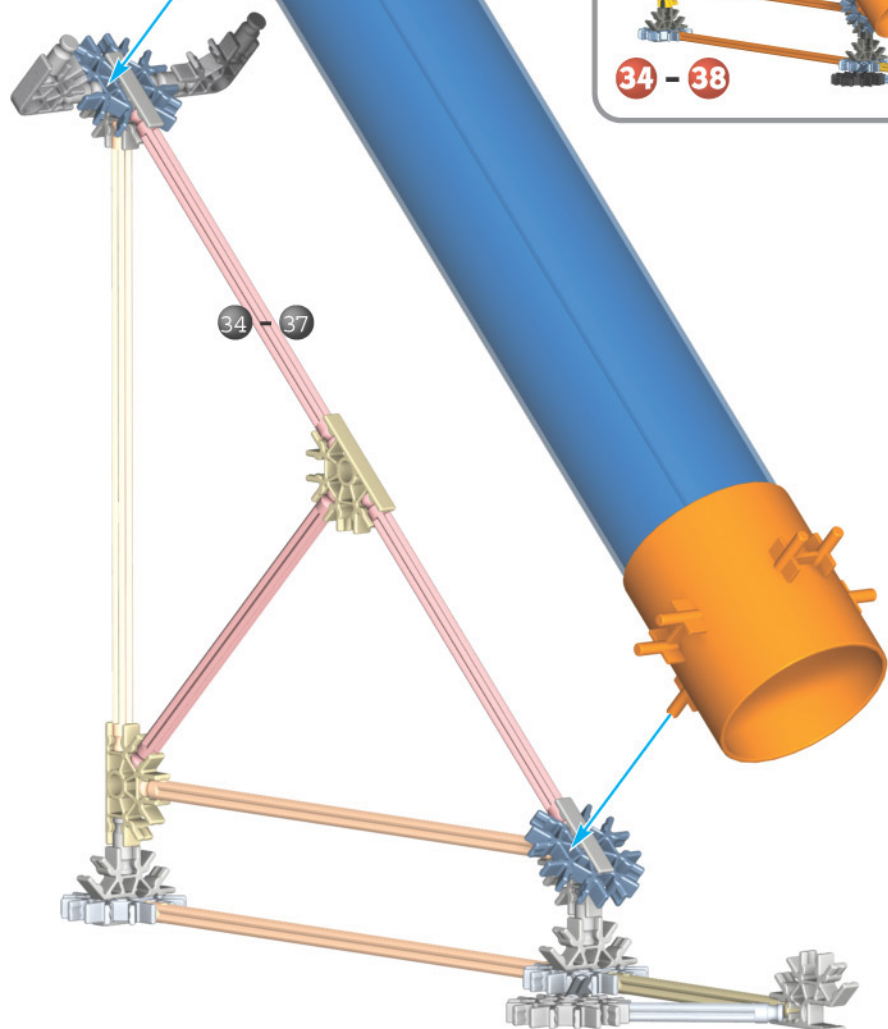

38

34 - 38



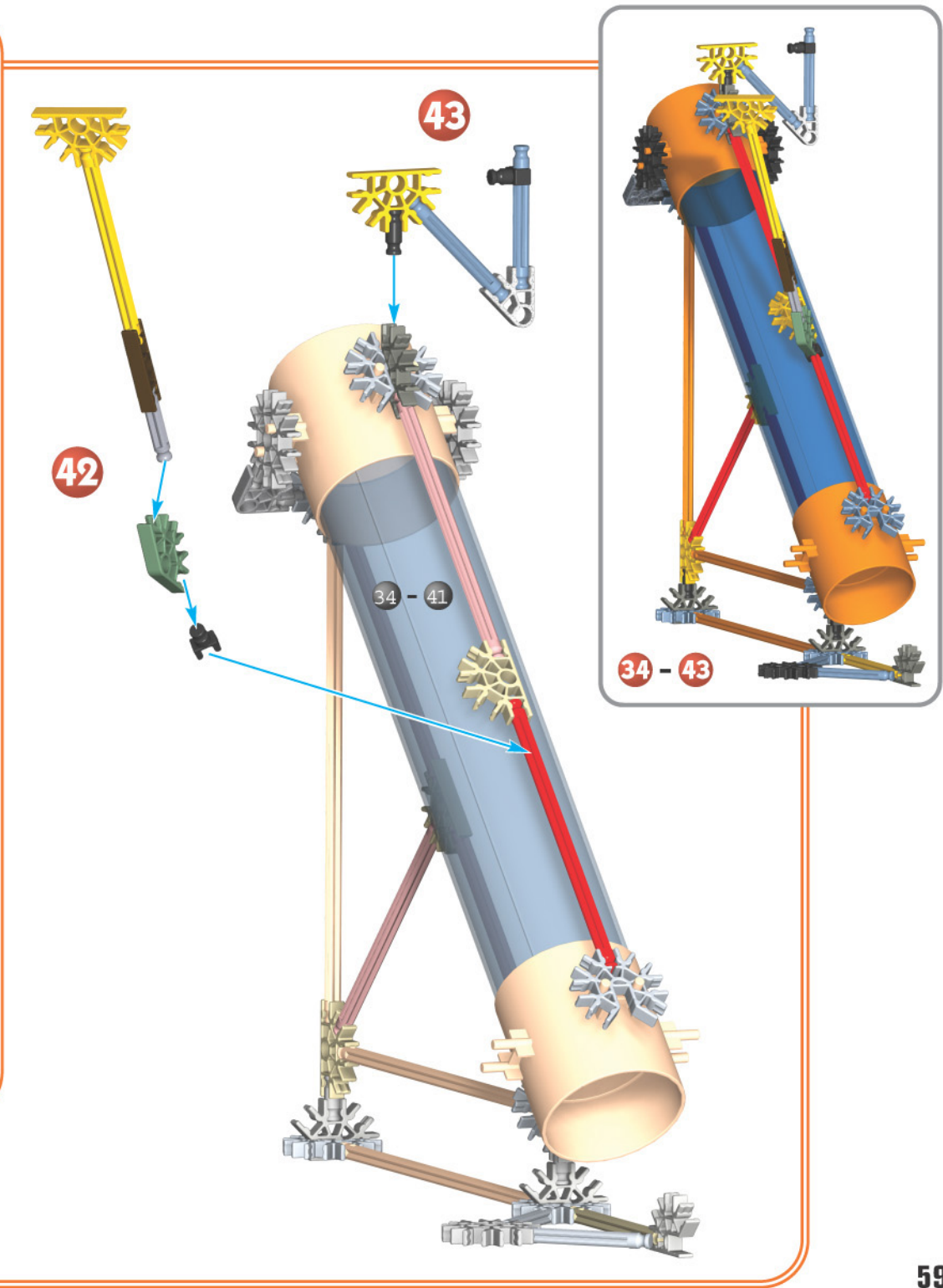
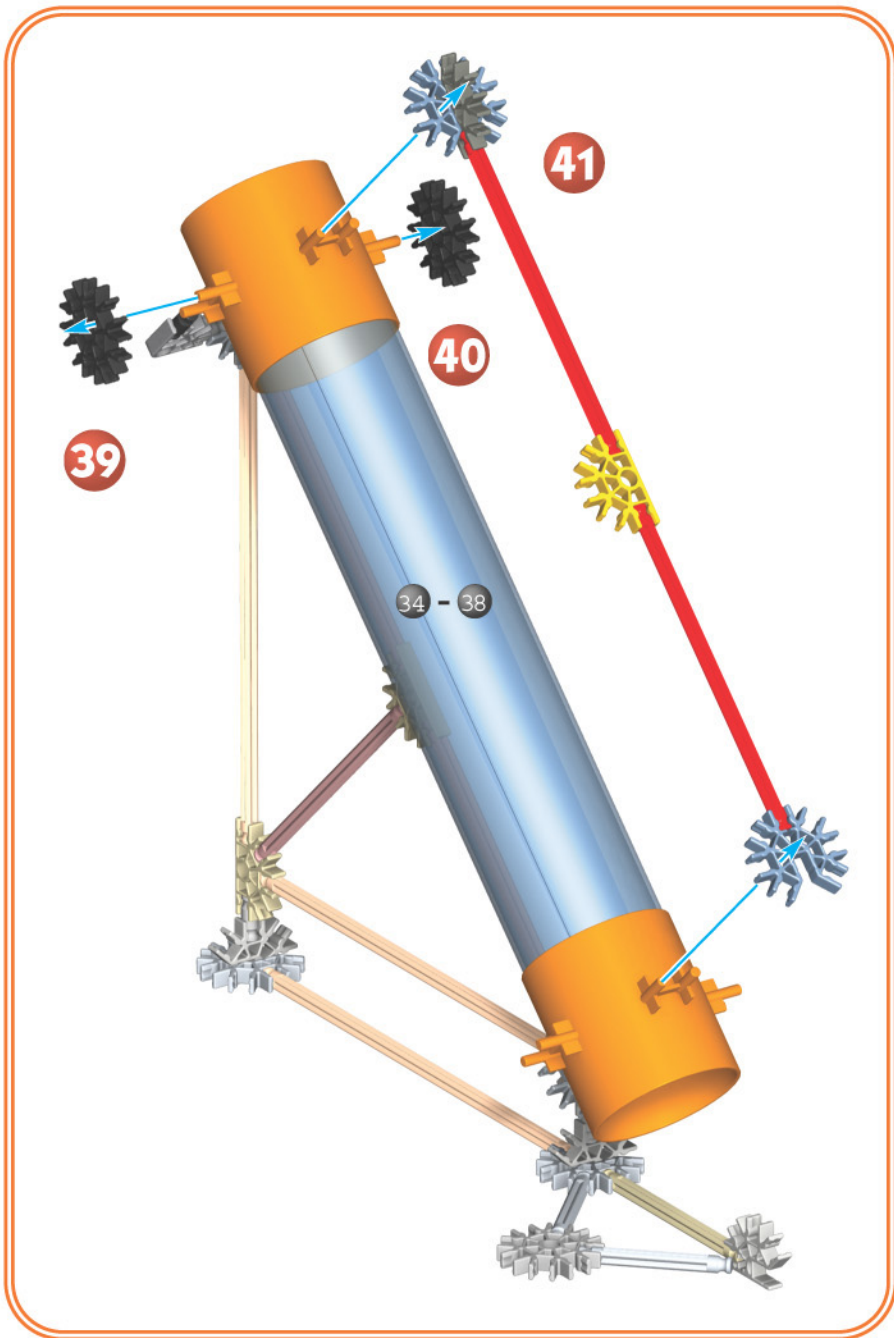



- ENG Join Section 3 to the built Sections.
- F Joins la section 3 aux sections déjà assemblées.
- E Junta la sección 3 con las secciones ya construidas.
- D Verbinde Abschnitt 3 mit den fertigen Abschnitten.
- NL Voeg deel 3 aan de gebouwde delen.
- I Collegare la sezione 3 alle sezioni costruite.
- P Junta a secção 3 às secções construídas.

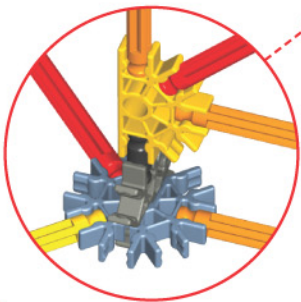
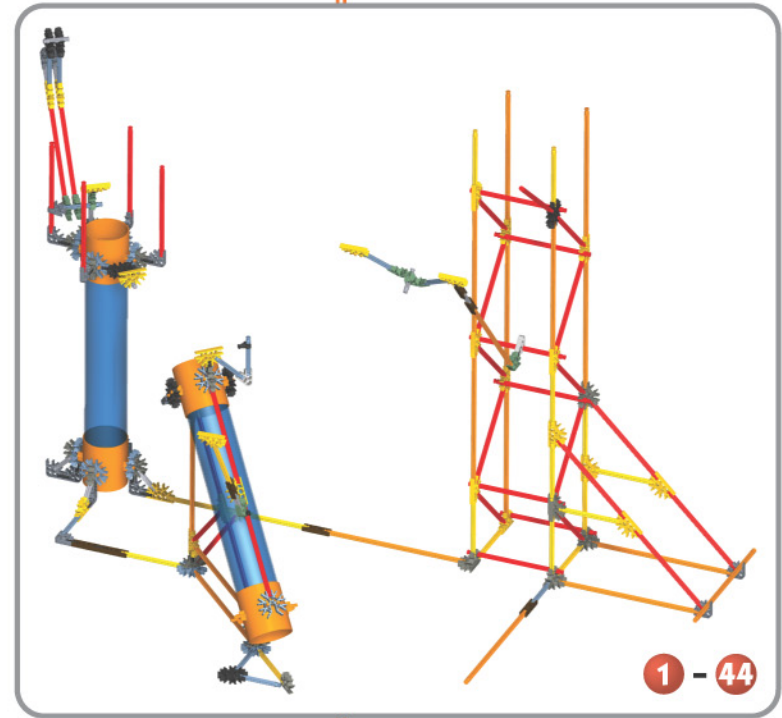
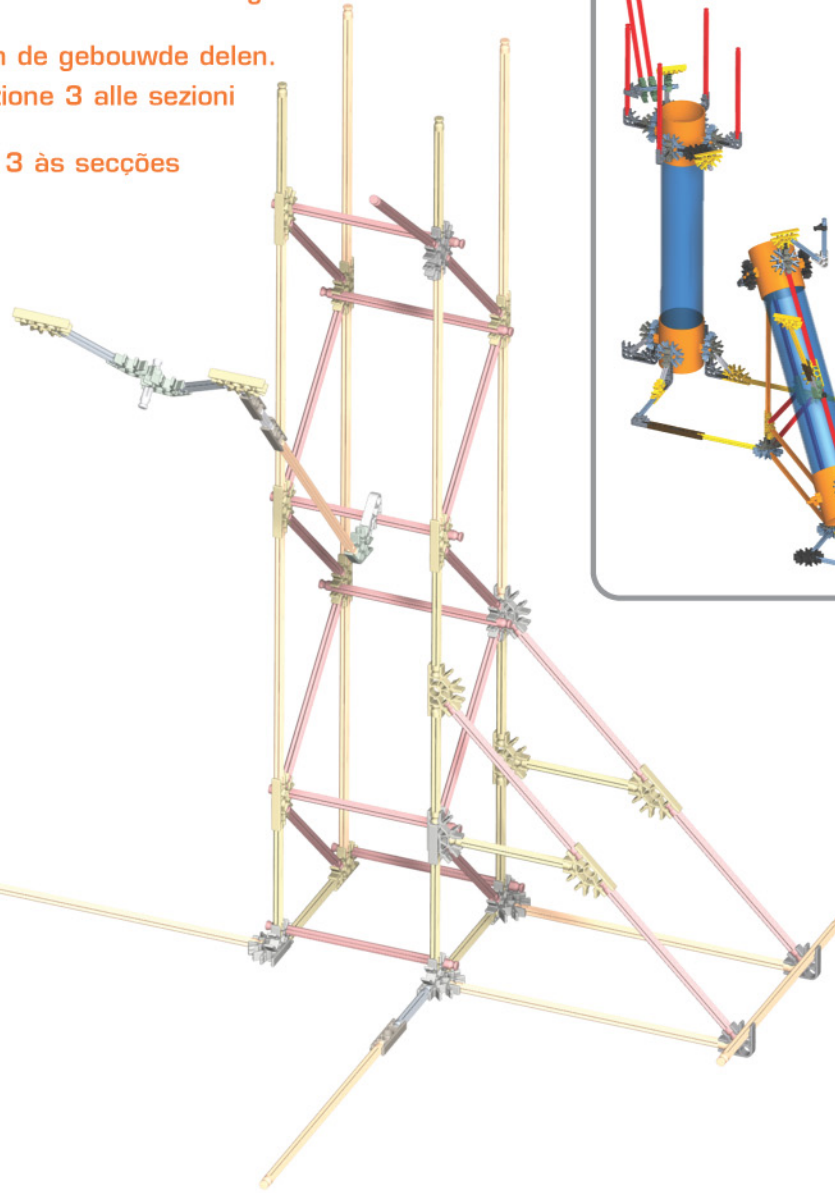
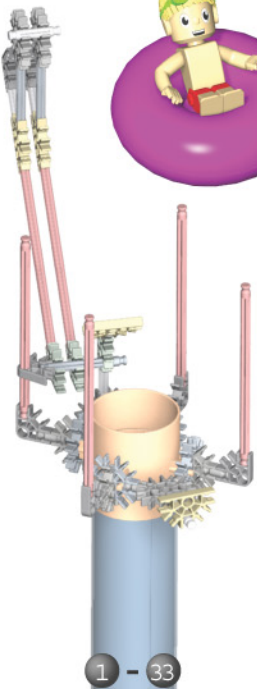

## SECTION 4

- F Section 4
- E Sección 4
- D Abschnitt 4
- NL Deel 4
- I Sezione 4
- P Secção 4

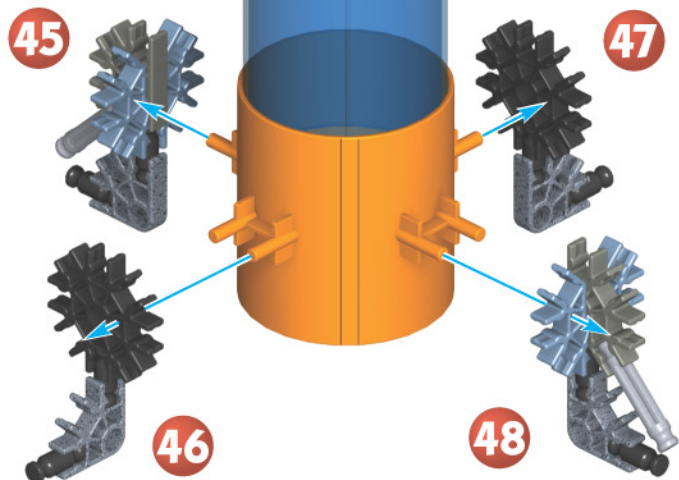

- ENG Line up grooves on blue Tube and Holder, then push together tightly.
- F Aligner les rainures sur le tuyau bleu et l'attache, puis pousse de sorte qu'ils tiennent bien ensemble.
- E Alinea las muescas en el tubo azul y el soporte. Luego presiona las piezas con firmeza para que queden bien encastradas.
- D Die Rillen auf den blauen Röhren und den Haltern müssen aufeinander ausgerichtet sein. Drücke sie fest zusammen.
- NL Richt de groeven op het blauwe buisje en de houder op mekaar af en duw ze dan goed tezamen.
- I Allineare i solchi sul tubo blu e il supporto, quindi premere insieme saldamente.
- P Alinha as ranhuras no Tubo Azul e no Fixador, seguidamente, empurra firmemente umas contra as outras.

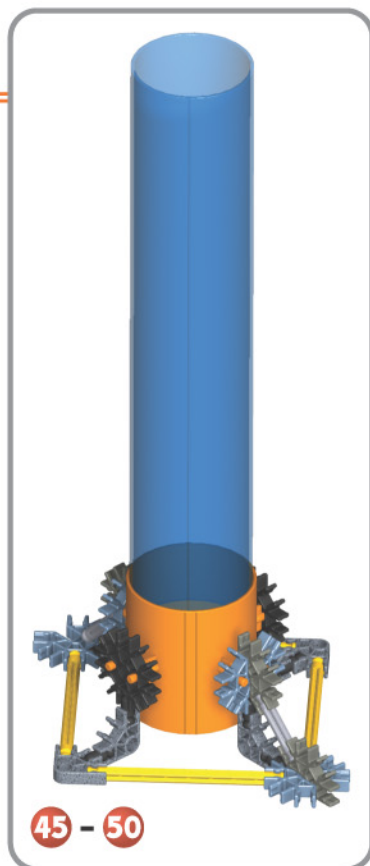
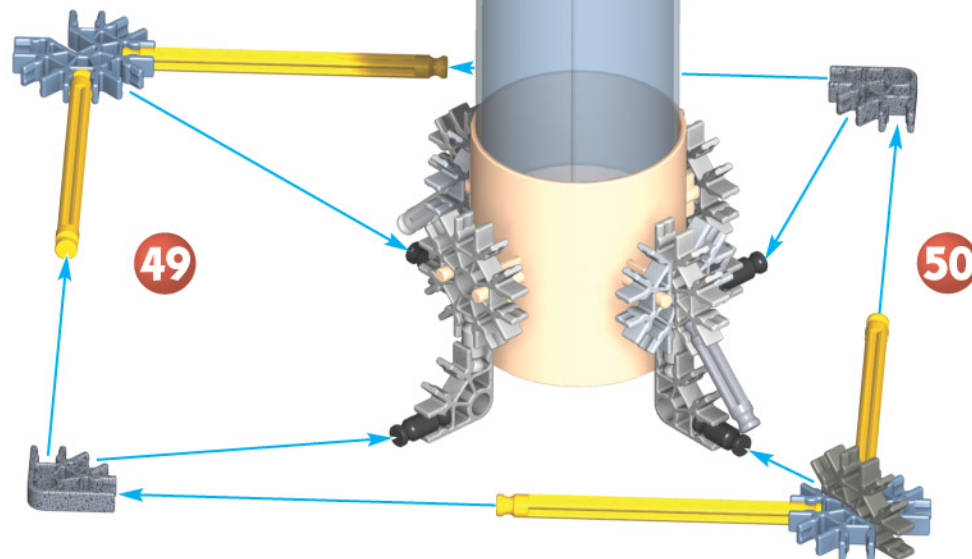

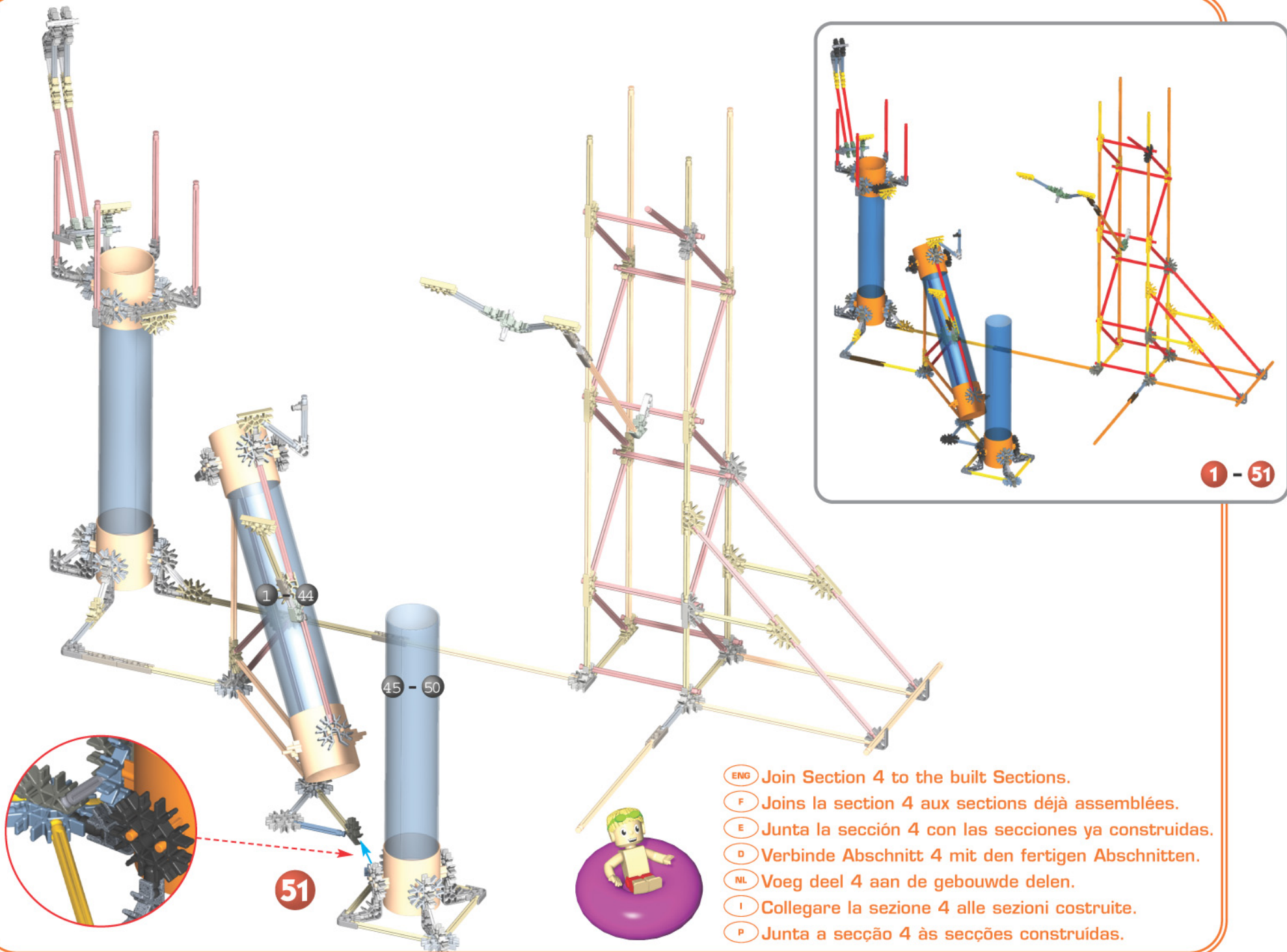

1 - 51

- (ENG) Join Section 4 to the built Sections.
- (F) Joins la section 4 aux sections déjà assemblées.
- (E) Junta la sección 4 con las secciones ya construidas.
- (D) Verbinde Abschnitt 4 mit den fertigen Abschnitten.
- (NL) Voeg deel 4 aan de gebouwde delen.
- (I) Collegare la sezione 4 alle sezioni costruite.
- (P) Junta a secção 4 às secções construídas.

## SECTION 5

- F Section 5
- E Sección 5
- D Abschnitt 5
- NL Deel 5
- I Sezione 5
- P Secção 5

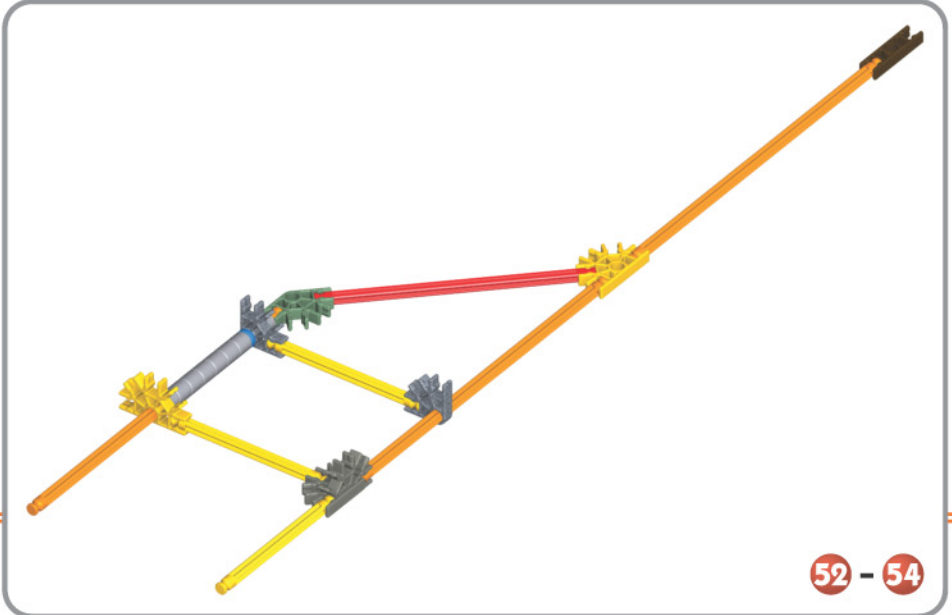
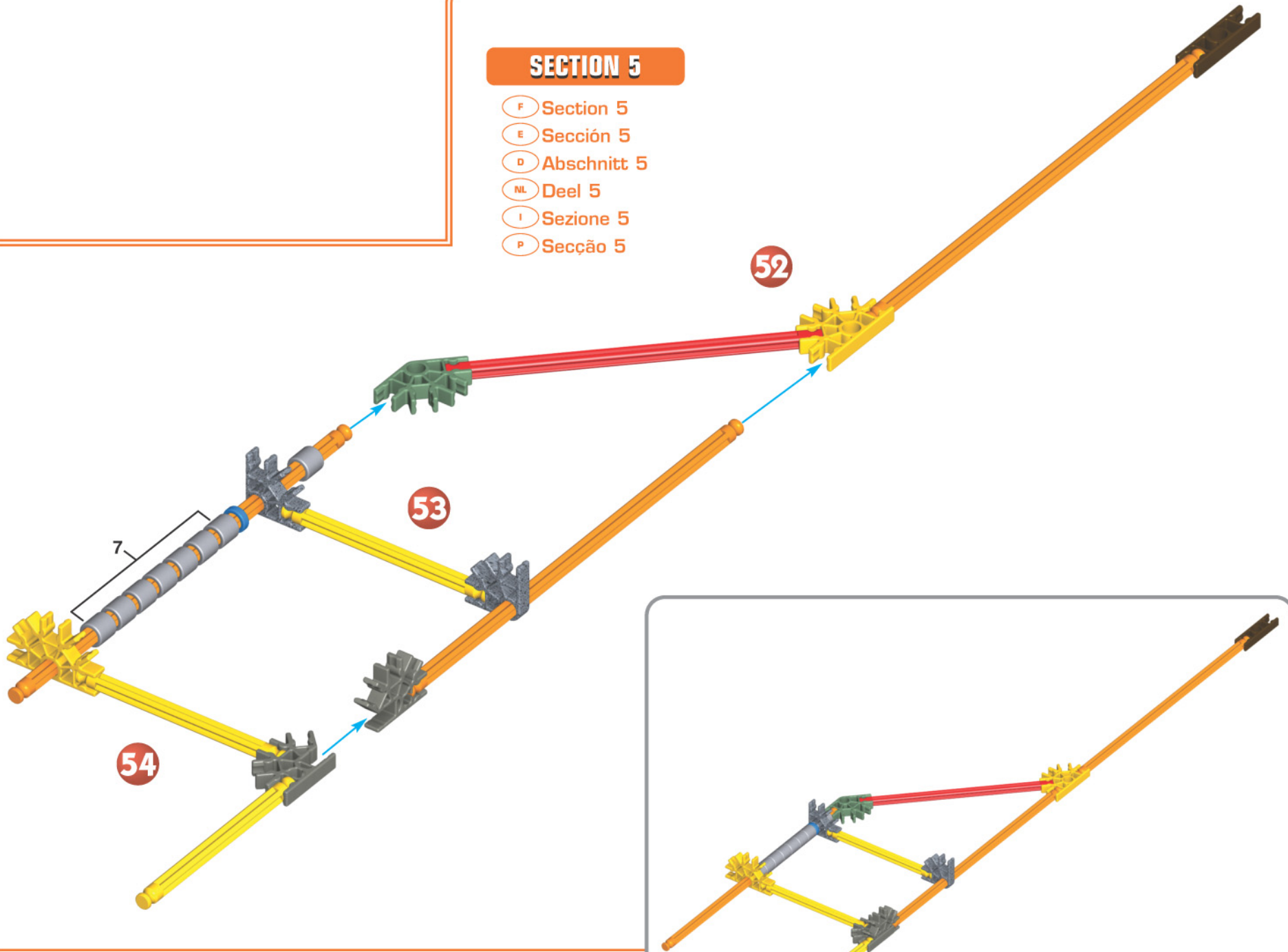

52 - 54

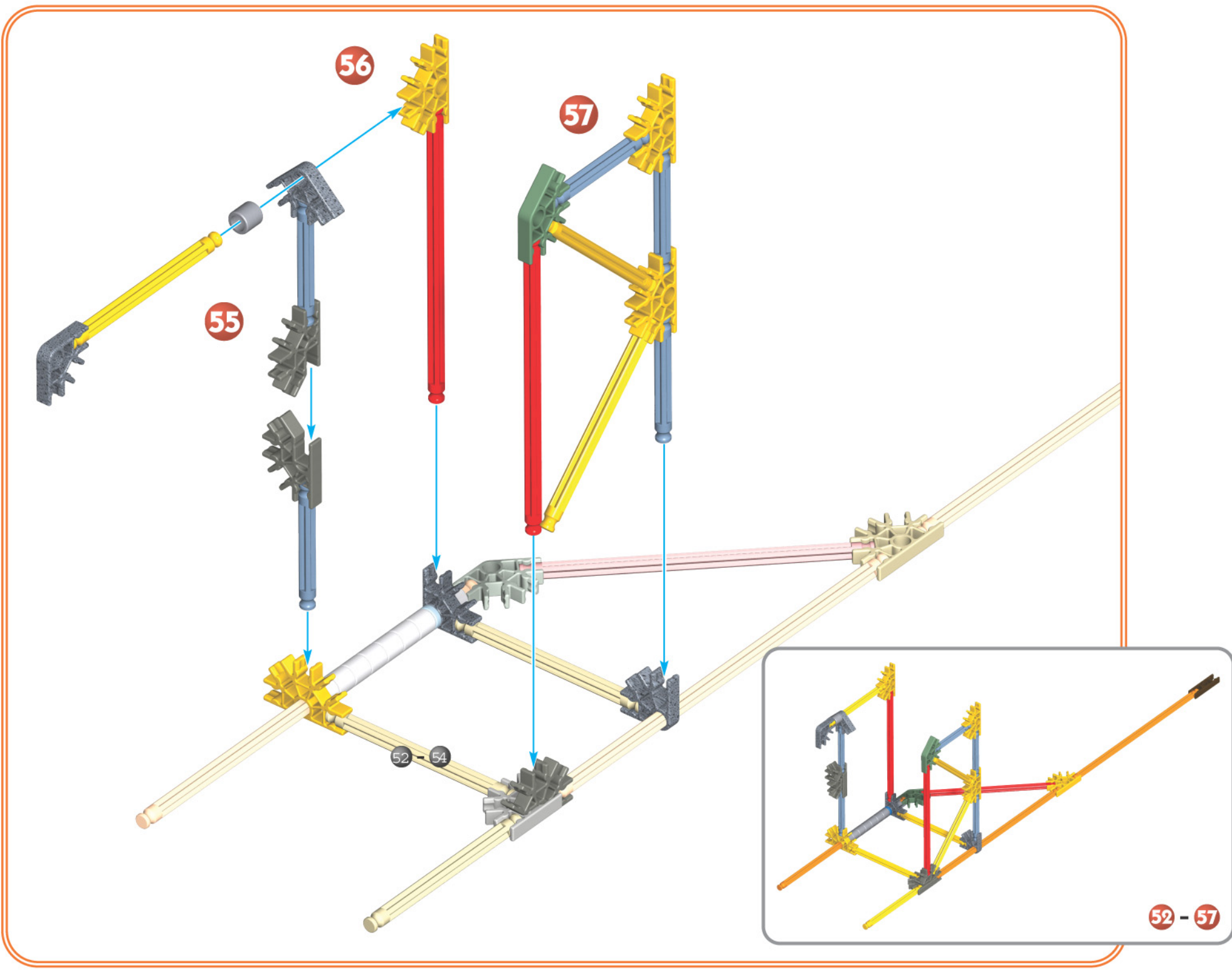

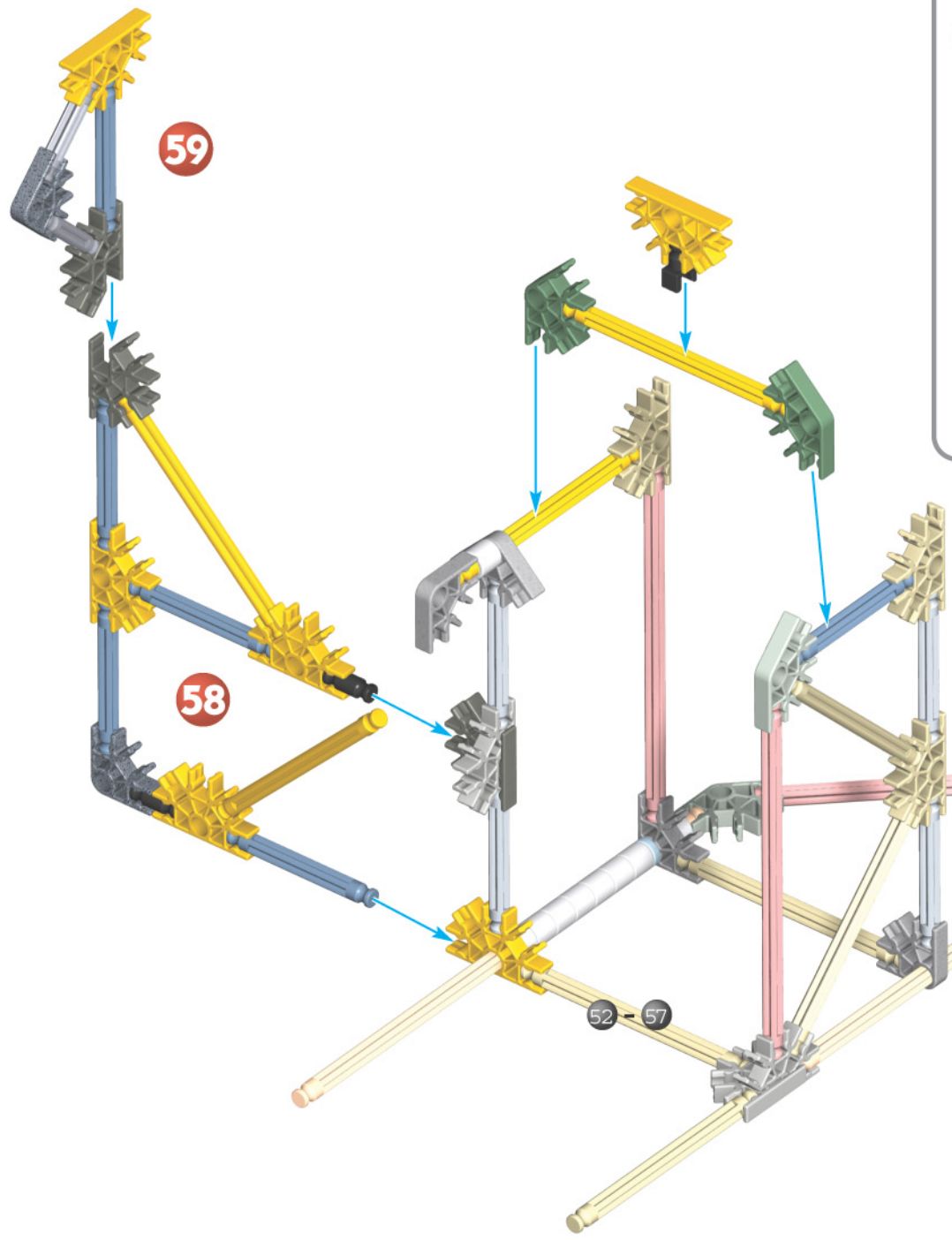

59

58

52 - 57

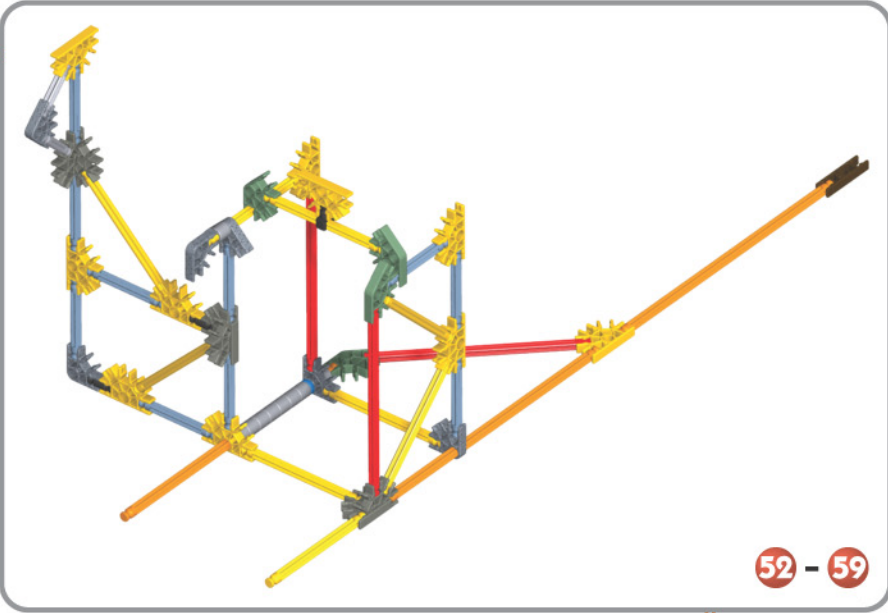

52 - 59

61

60

62

52 - 59

52

62

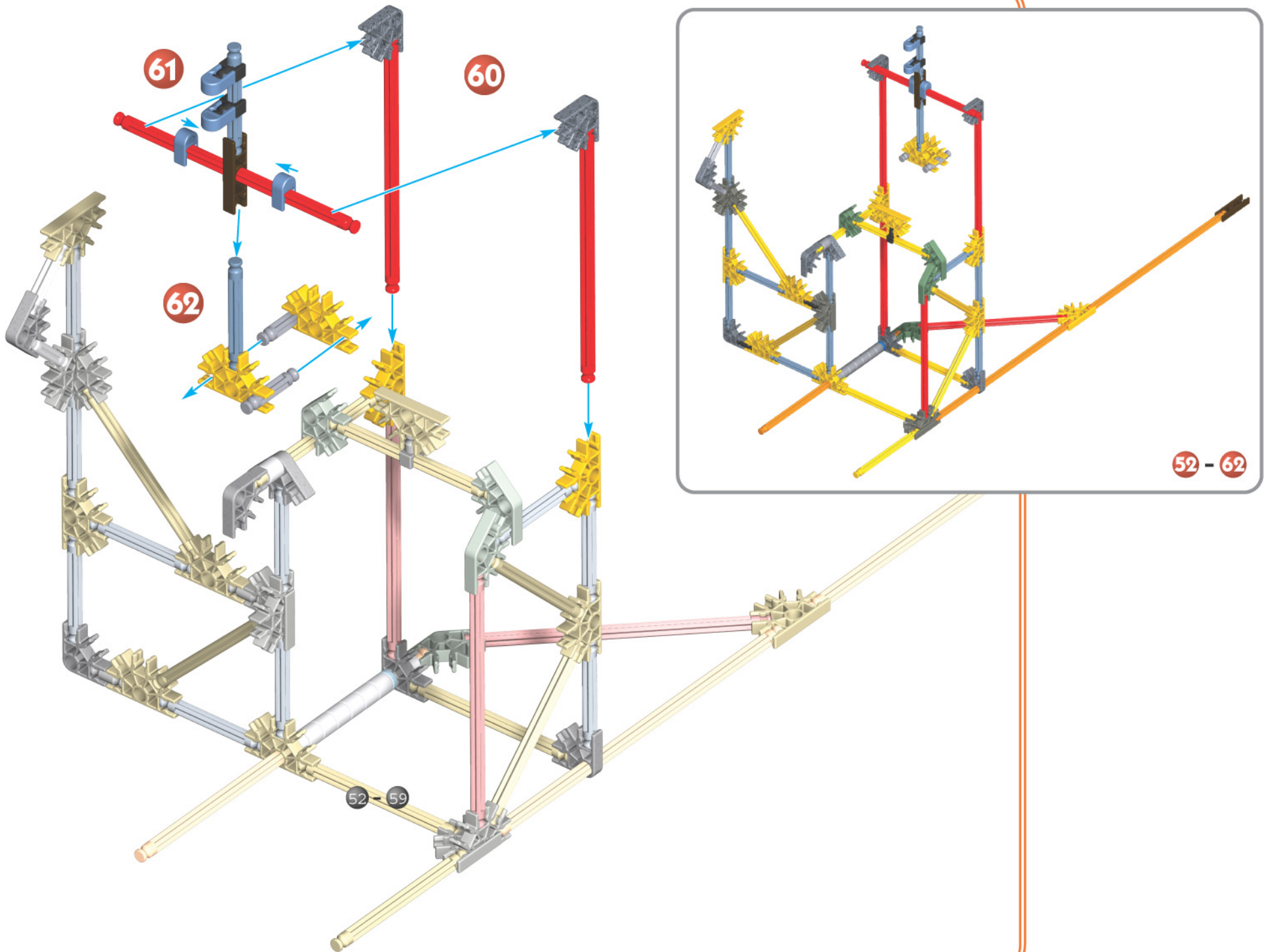

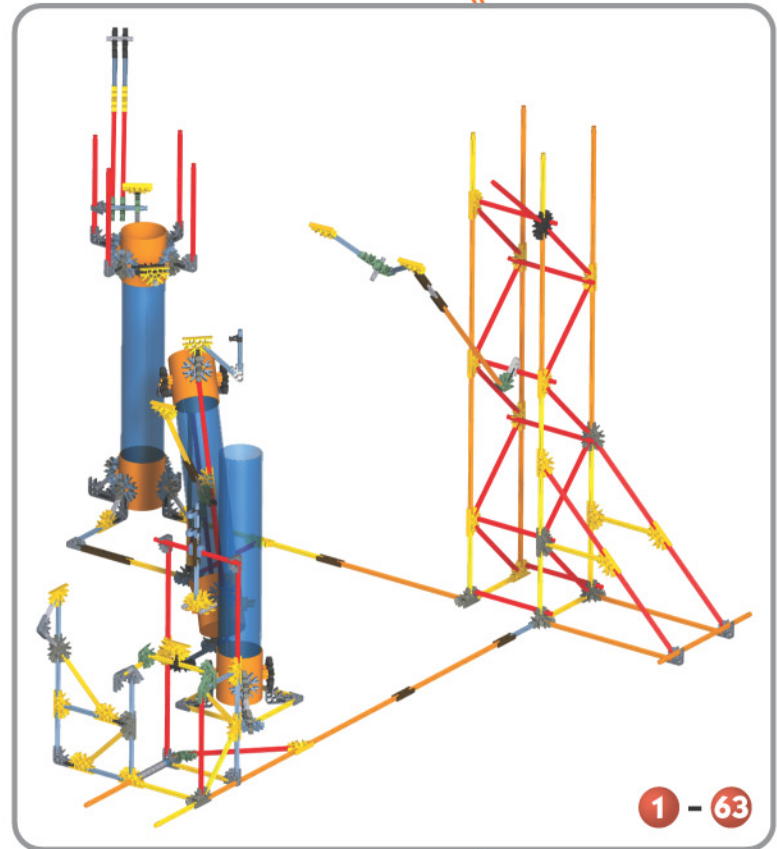
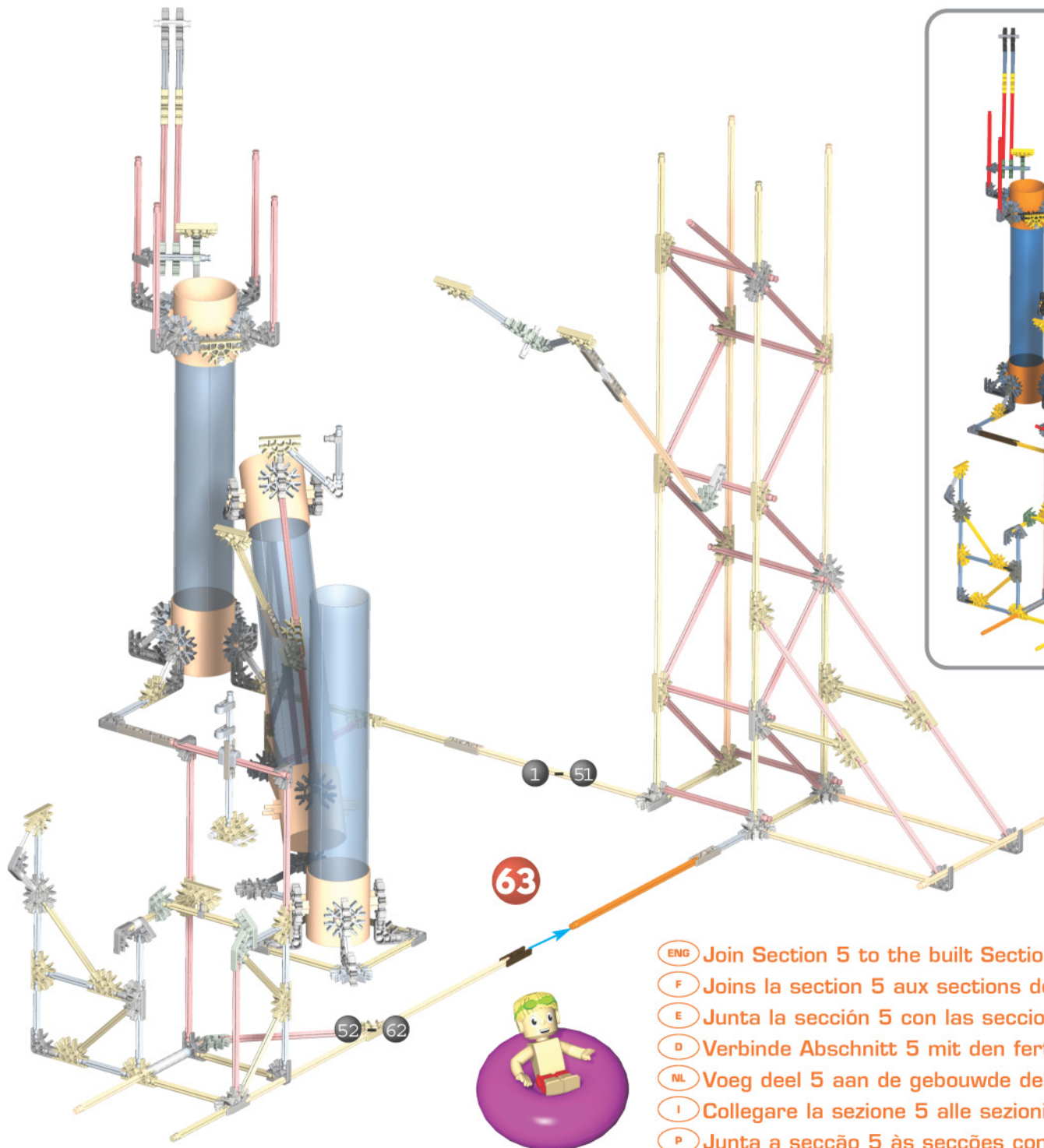

- (ENG) Join Section 5 to the built Sections.
- (F) Joins la section 5 aux sections déjà assemblées.
- (E) Junta la sección 5 con las secciones ya construidas.
- (D) Verbinde Abschnitt 5 mit den fertigen Abschnitten.
- (NL) Voeg deel 5 aan de gebouwde delen.
- (I) Collegare la sezione 5 alle sezioni costruite.
- (P) Junta a secção 5 às secções construídas.

## SECTION 6

- F Section 6
- E Sección 6
- D Abschnitt 6
- NL Deel 6
- I Sezione 6
- P Secção 6

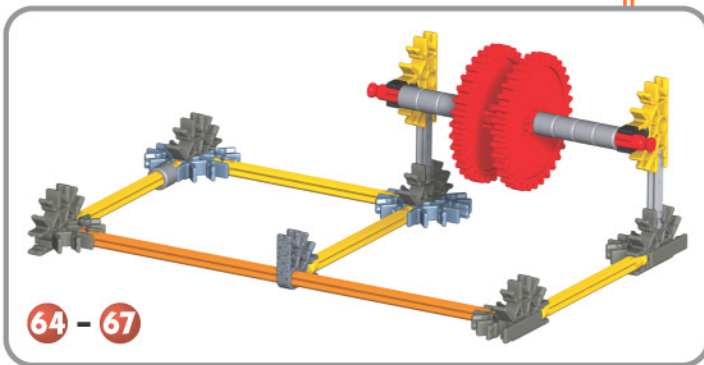
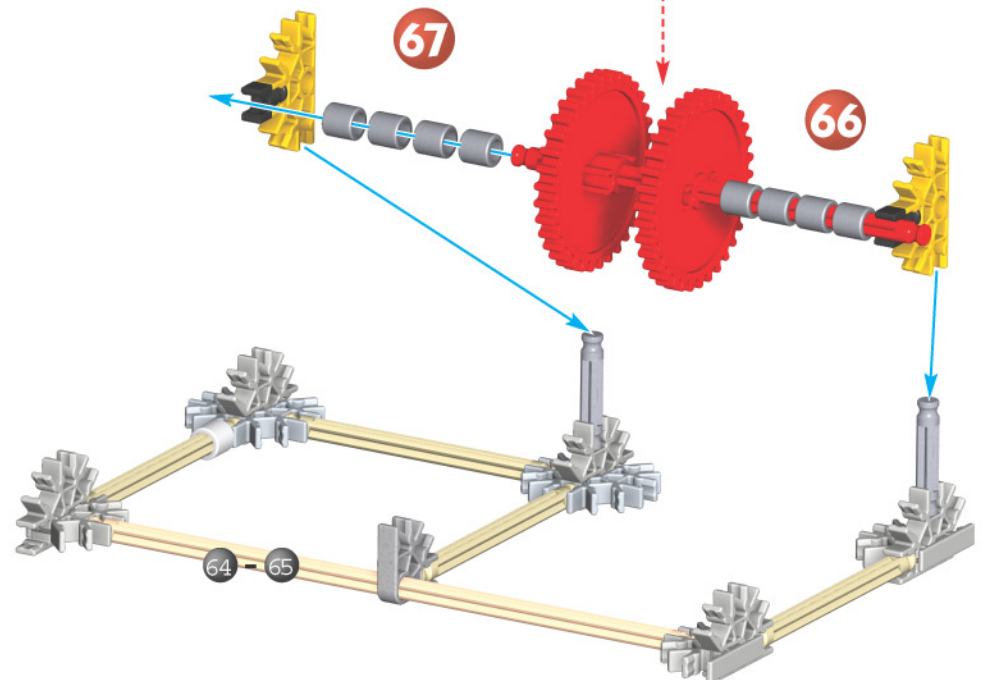
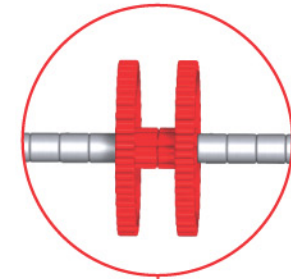
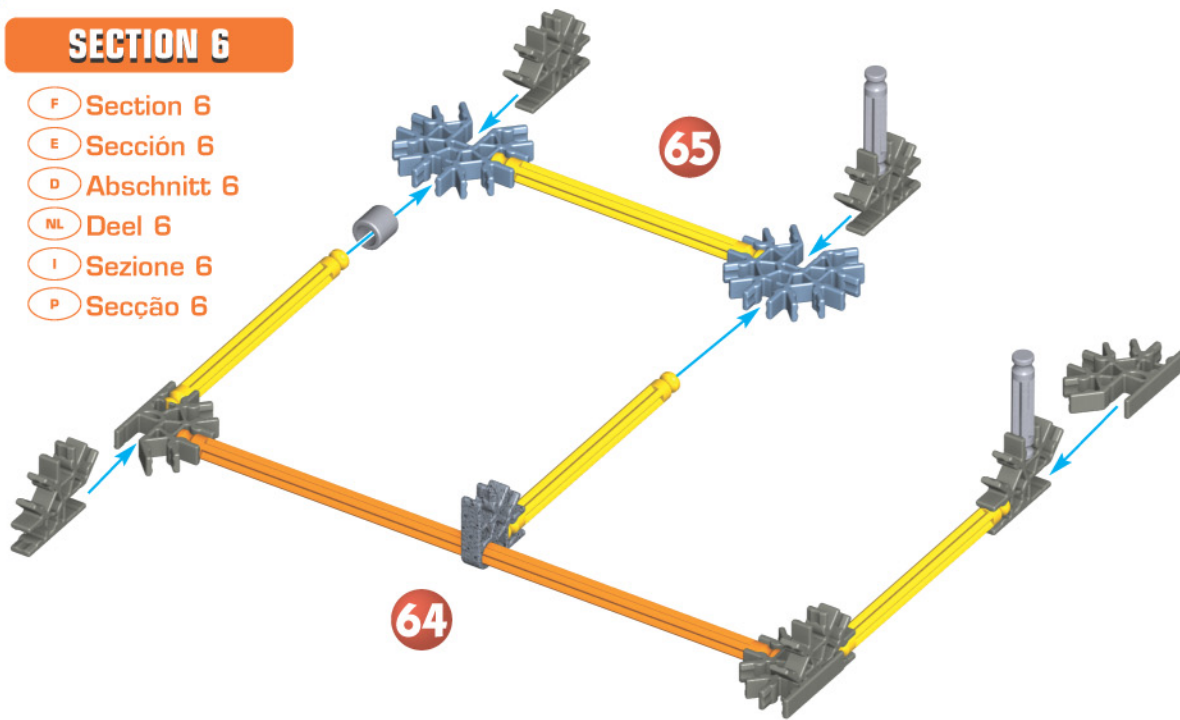

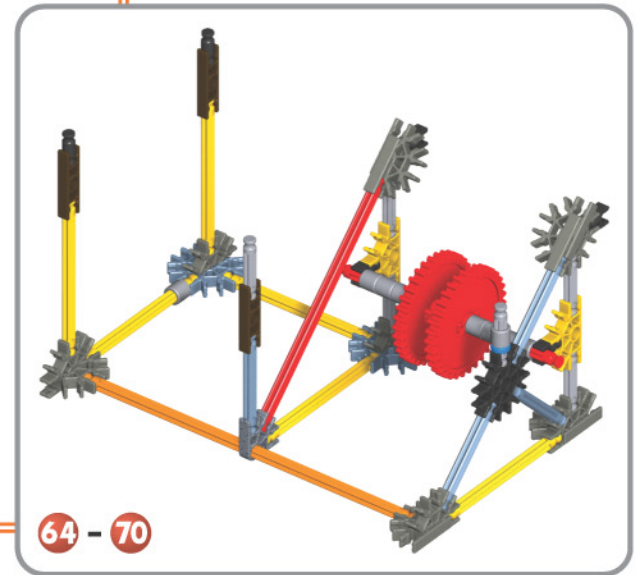
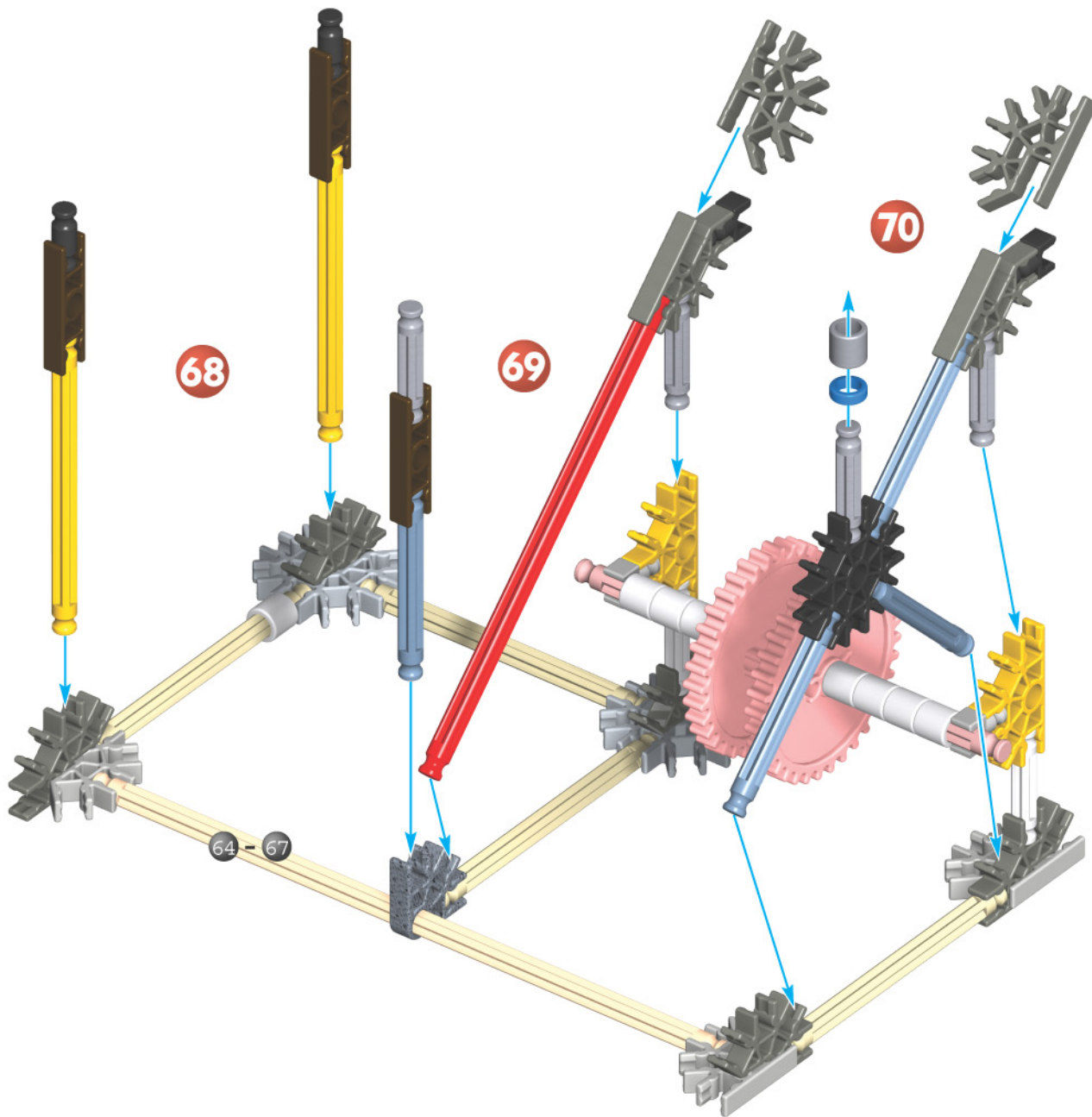

73

72

71

64 - 73

64 - 70

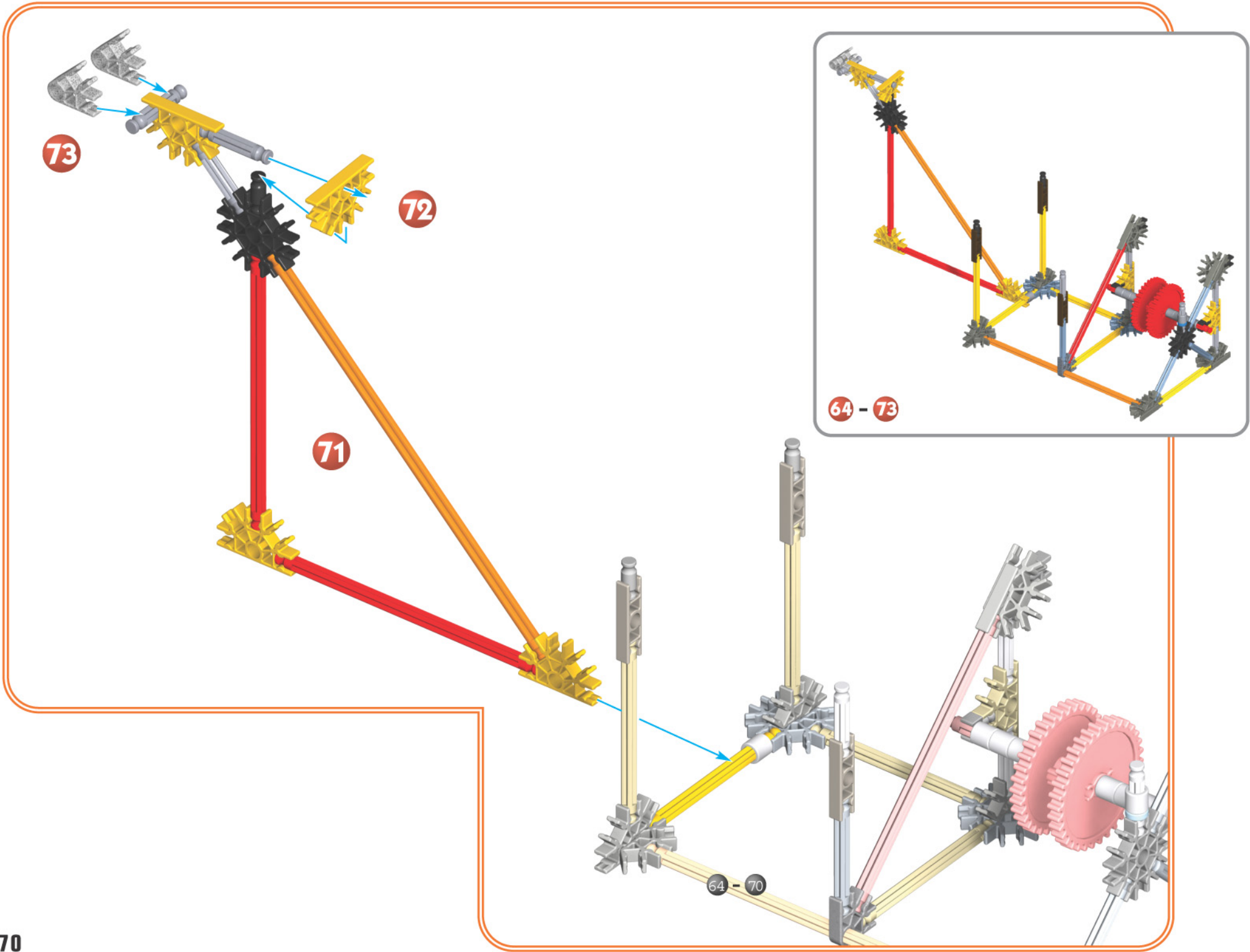

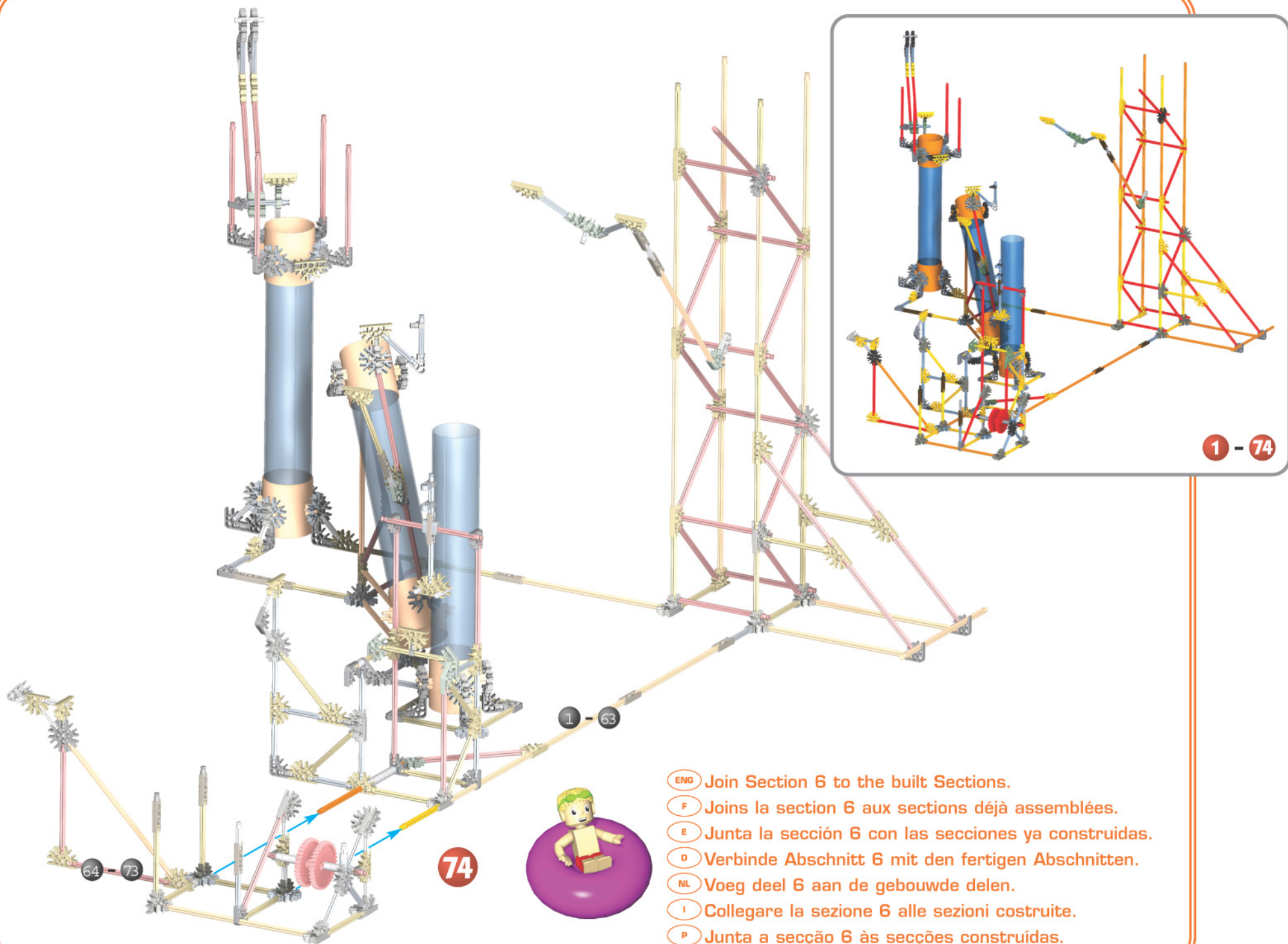

**74**

- (ENG)** Join Section 6 to the built Sections.
- (F)** Joins la section 6 aux sections déjà assemblées.
- (E)** Junta la sección 6 con las secciones ya construidas.
- (D)** Verbinde Abschnitt 6 mit den fertigen Abschnitten.
- (NL)** Voeg deel 6 aan de gebouwde delen.
- (I)** Collegare la sezione 6 alle sezioni costruite.
- (P)** Junta a secção 6 às secções construídas.

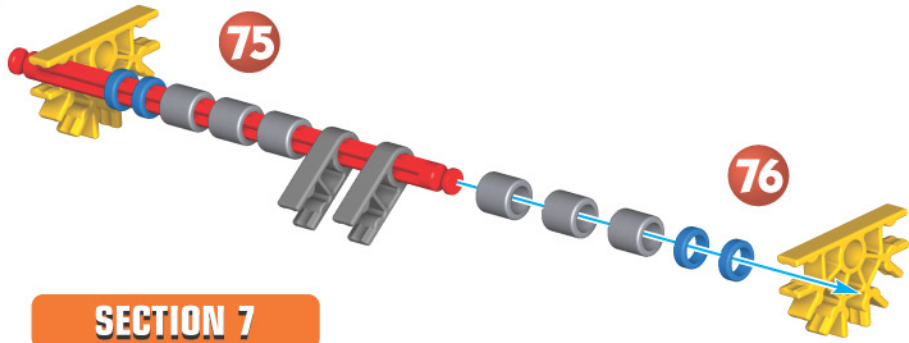

**SECTION 7**

- F Section 7
- E Sección 7
- D Abschnitt 7
- NL Deel 7
- I Sezione 7
- P Secção 7

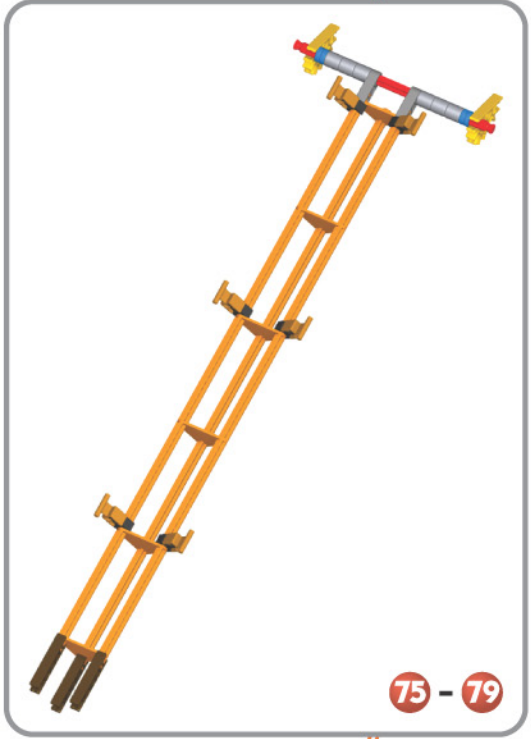
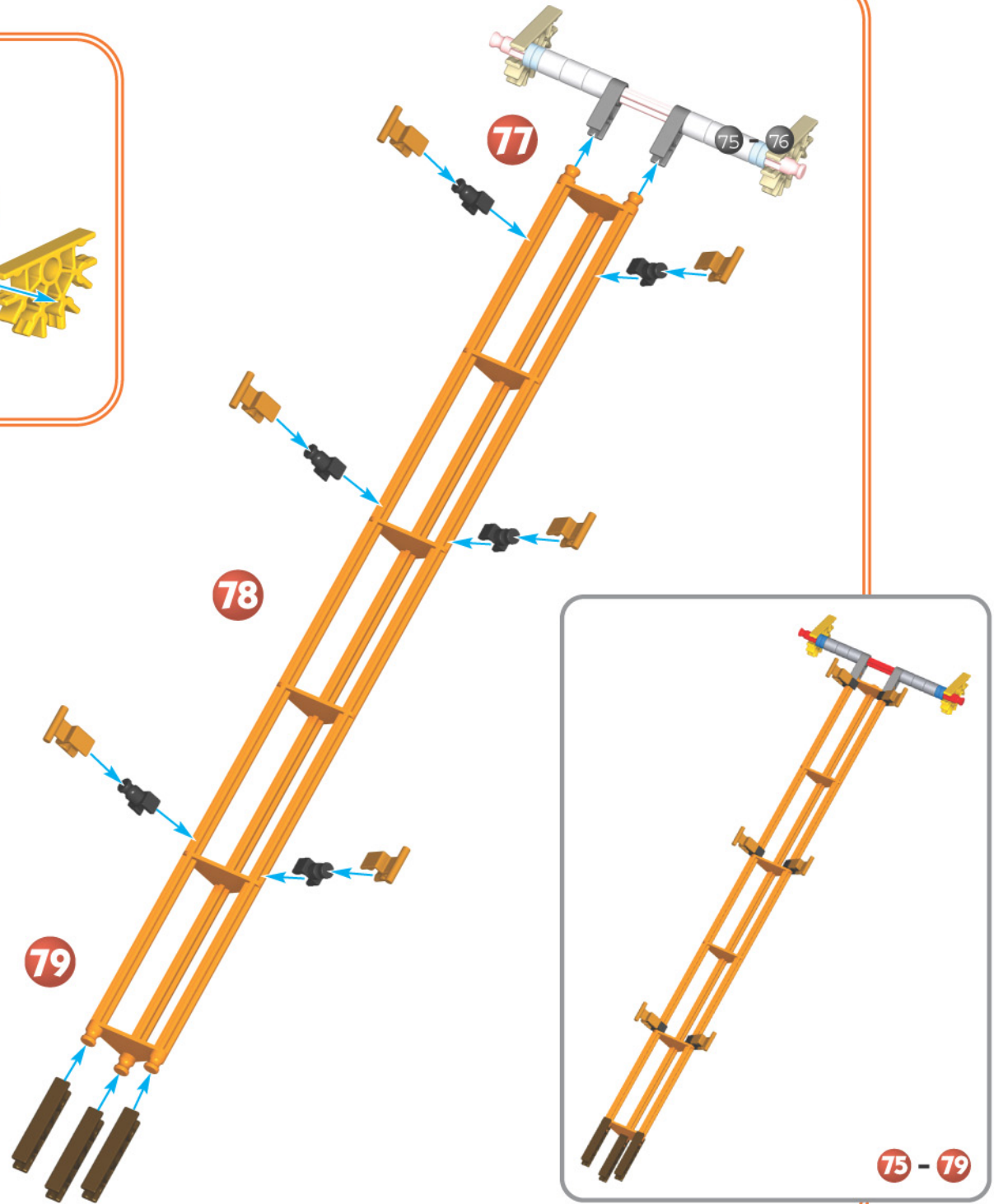

75 - 79

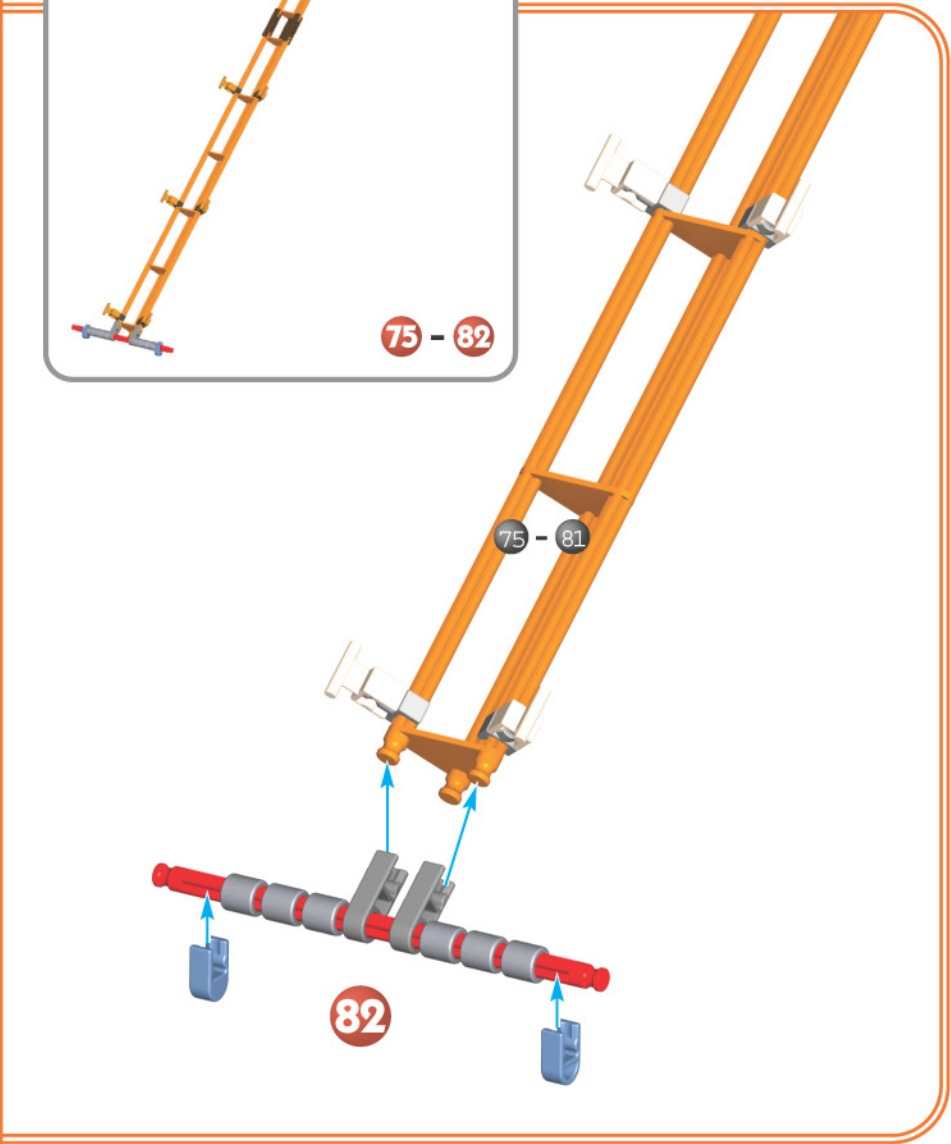
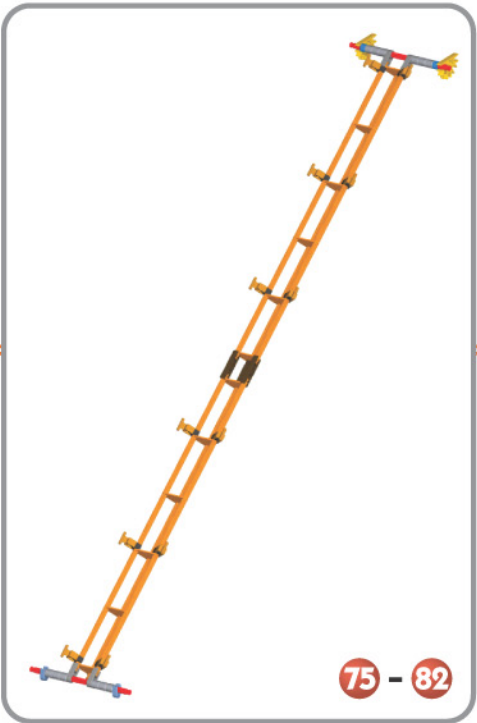
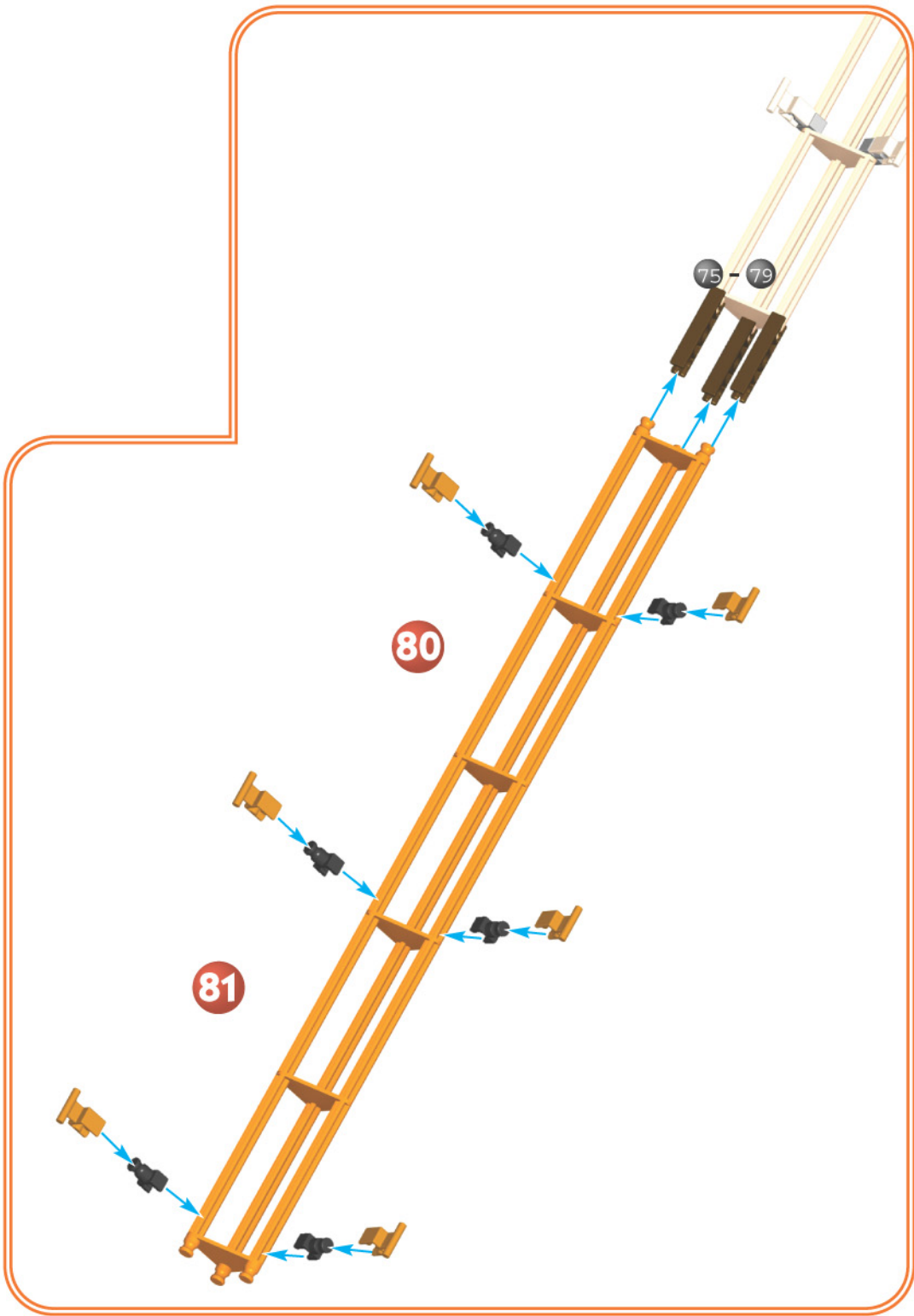



- ENG** Join Section 7 to the built Sections.
- F** Joins la section 7 aux sections déjà assemblées.
- E** Junta la sección 7 con las secciones ya construidas.
- D** Verbinde Abschnitt 7 mit den fertigen Abschnitten.
- NL** Voeg deel 7 aan de gebouwde delen.
- I** Collegare la sezione 7 alle sezioni costruite.
- P** Junta a secção 7 às secções construídas.

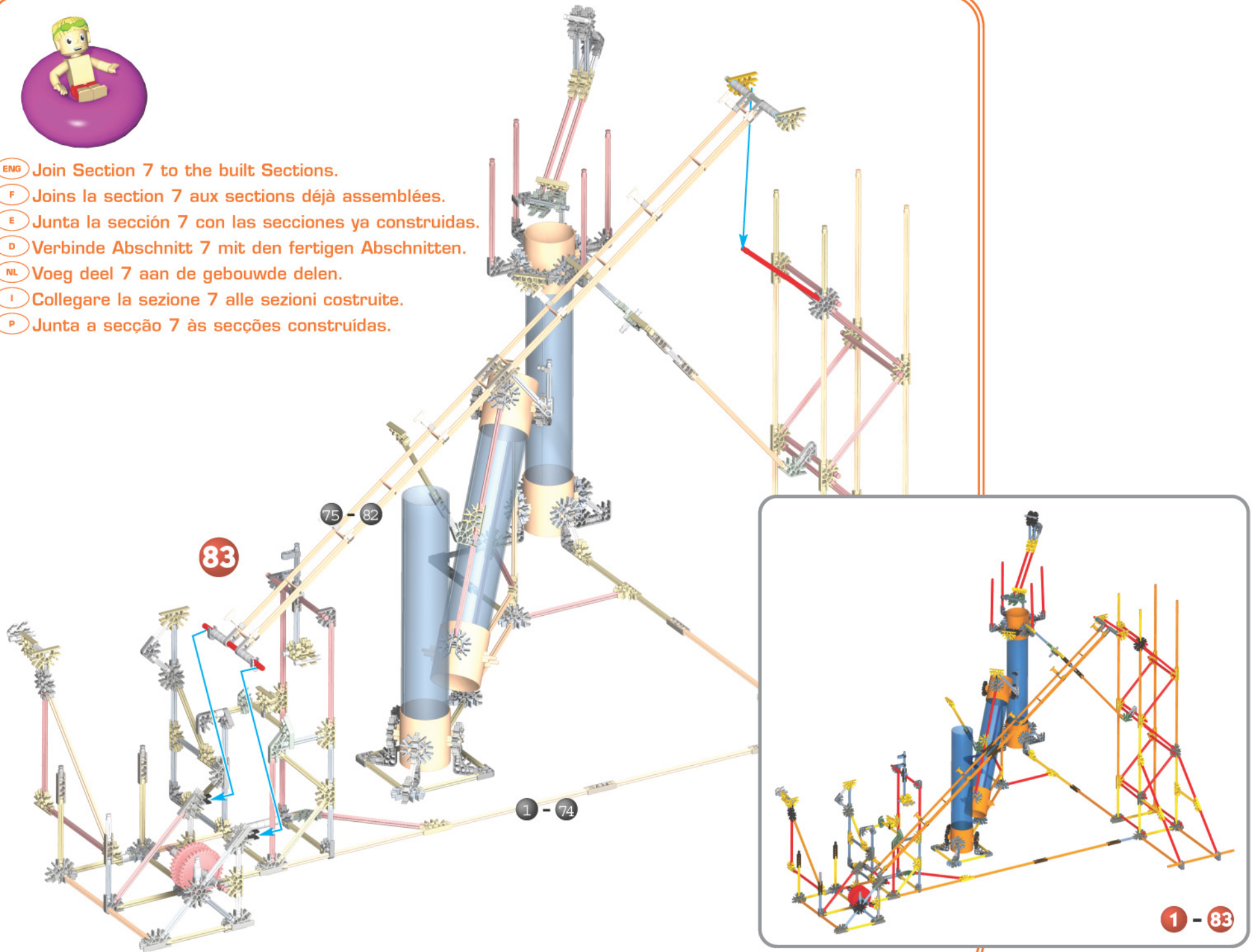

84

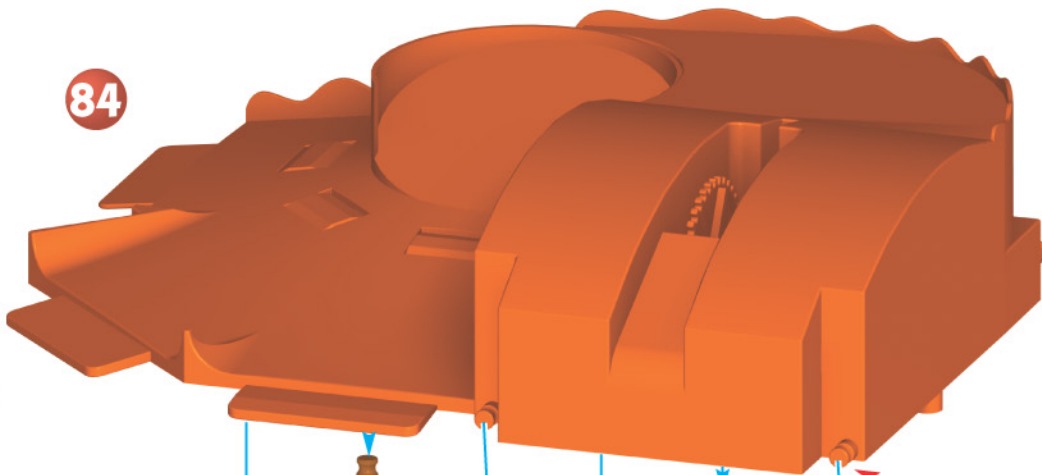

ENG Holes for Rods.

D Löcher für die Stäbe.

F Trous pour les tiges.

NL Gatens voor de stangen.

E Agujeros para insertar las varillas.

I Fori per le aste.

P Orificios para as Hastes.

ENG Did you install 3 C (LR14) Batteries?

F As-tu installé 3 piles C (ou LR14) ?

E ¿Instalaste 3 pilas C (o LR14)?

D Hast du 3 Batterien der Baugröße C (oder LR14) eingelegt?

NL Heb je er 3 C (of LR14) batterijen ingestoken?

I Hai installato le batterie 3 C (o LR14)?

P As 3 pilhas C (ou LR14) já estão instaladas?

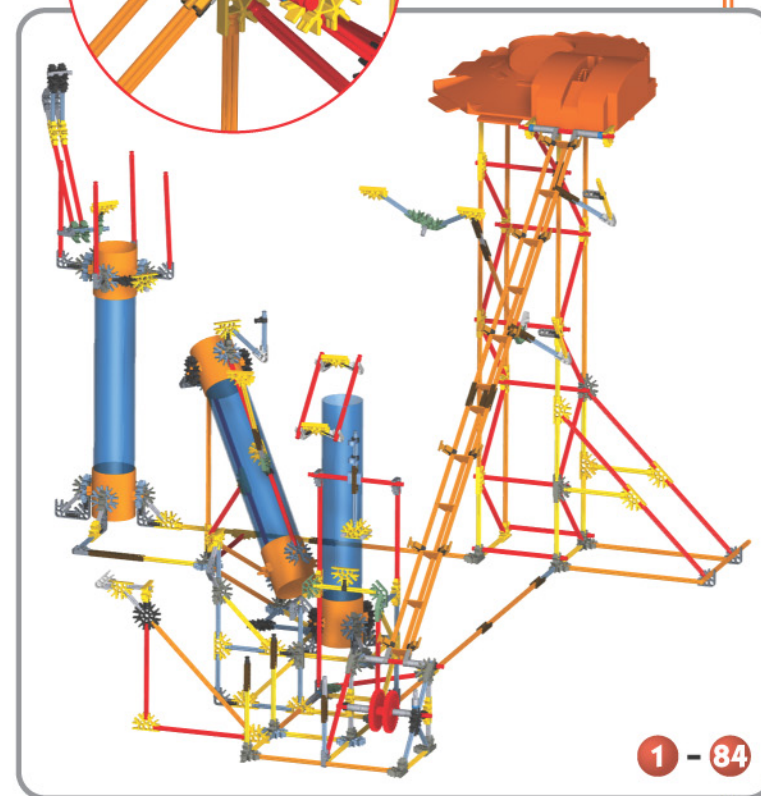
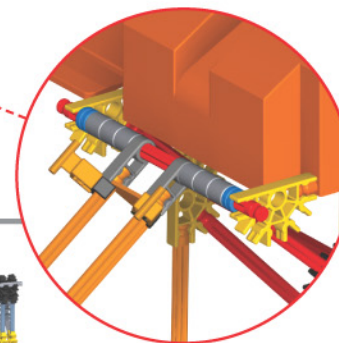

1 - 84

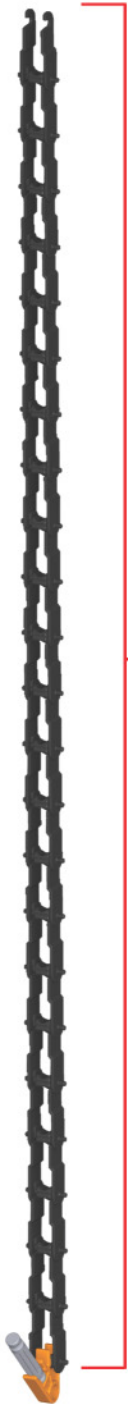

85

24

x3



86

23

x1

 x95

- (ENG) Attach Chain Links in the same direction. The hooks should face up as they go uphill on the model.
- (F) Fixe les maillons de la chaîne dans le même sens. Les crochets doivent être tournés vers le haut vu qu'ils montent la pente sur le modèle.
- (E) Conecta los eslabones de la cadena en la misma dirección. Los ganchos deben estar orientados hacia arriba a medida que van ascendiendo en el modelo.
- (D) Bringe die Kettenglieder in der gleichen Richtung an. Die Haken müssen bei der Aufwärtsbewegung nach oben zeigen.
- (NL) Maak de kettingschakels vast in dezelfde richting. De haken moeten naar boven gericht zijn terwijl ze de helling van het model oplopen.
- (I) Collegare le maglie della catena nella stessa direzione. I ganci dovrebbero essere rivolti verso l'alto mentre si spostano verso l'alto sul modello.
- (P) Prende os Elos de União da Corrente seguindo a mesma direção. Os ganchos devem estar voltados para cima quando em movimento ascendente no modelo.

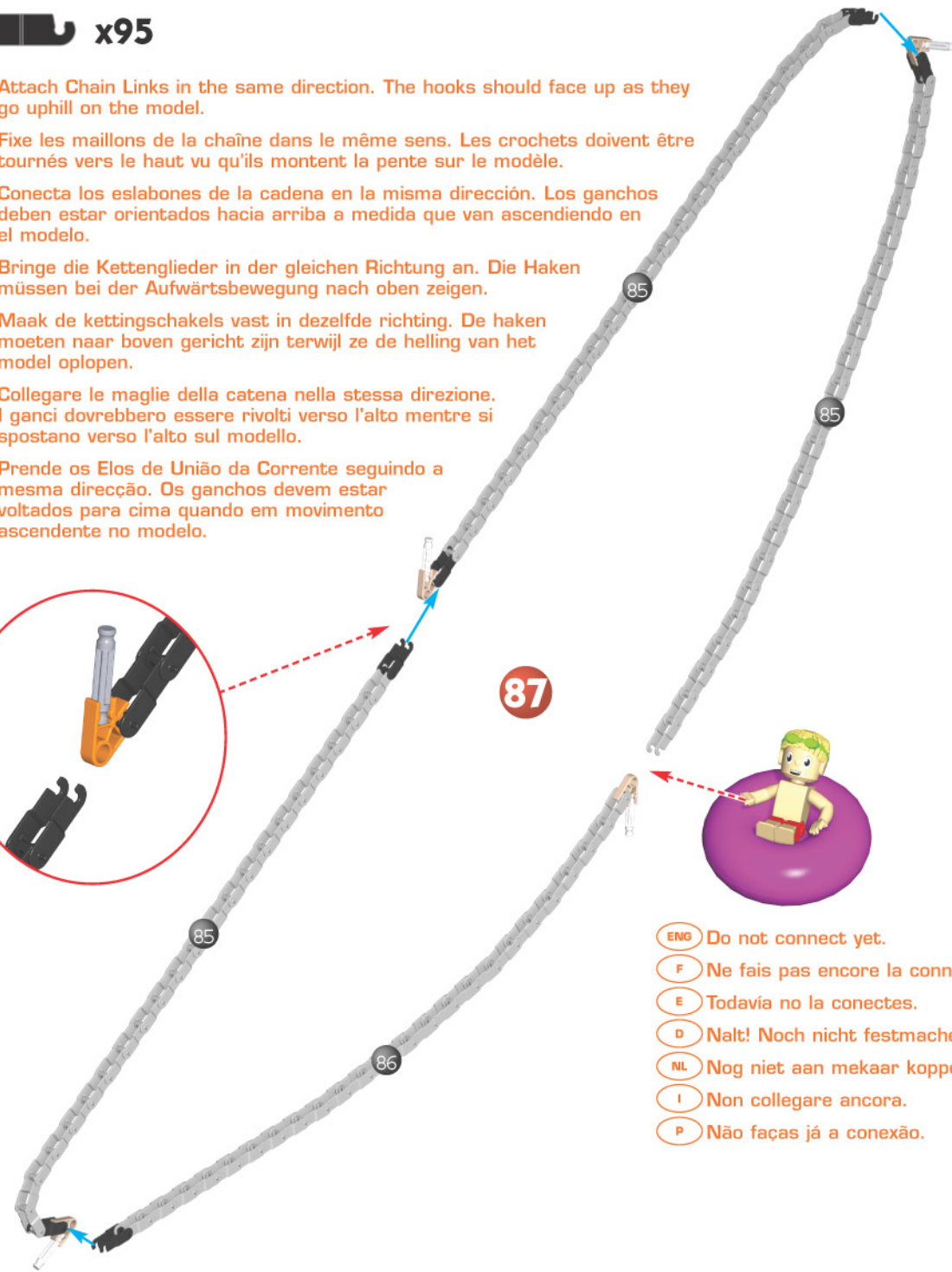
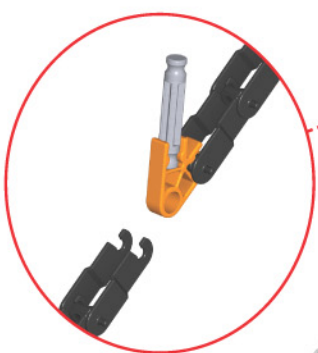

87

- (ENG) Do not connect yet.
- (F) Ne fais pas encore la connexion.
- (E) Todavía no la conectes.
- (D) Nalt! Noch nicht festmachen.
- (NL) Nog niet aan mekaar koppelen.
- (I) Non collegare ancora.
- (P) Não faça já a conexão.

ENG The "pick-up" Rods face up.

F Les tiges de « ramassage » sont tournées vers le haut.

E Las varillas con agarraderas se orientan hacia arriba.

D Diese Förderstäbe müssen nach oben zeigen.

NL De "pick-up" stangen zijn naar boven gericht.

I Le aste di "sollevamento" sono rivolte verso l'alto.

P As Hastes "acopladoras" apresentam-se viradas para cima.

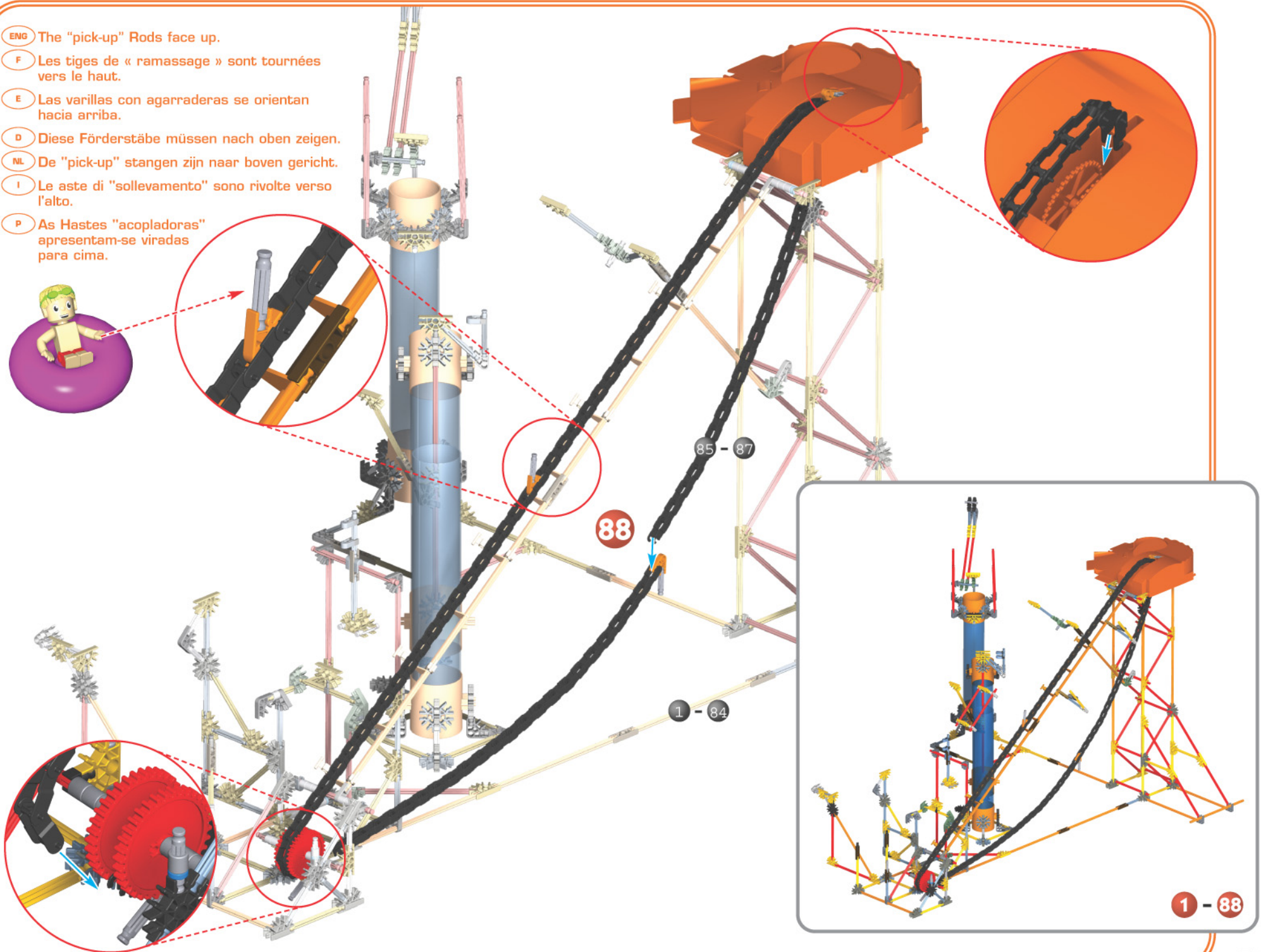
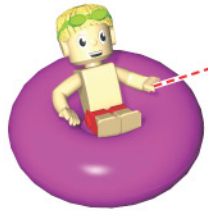

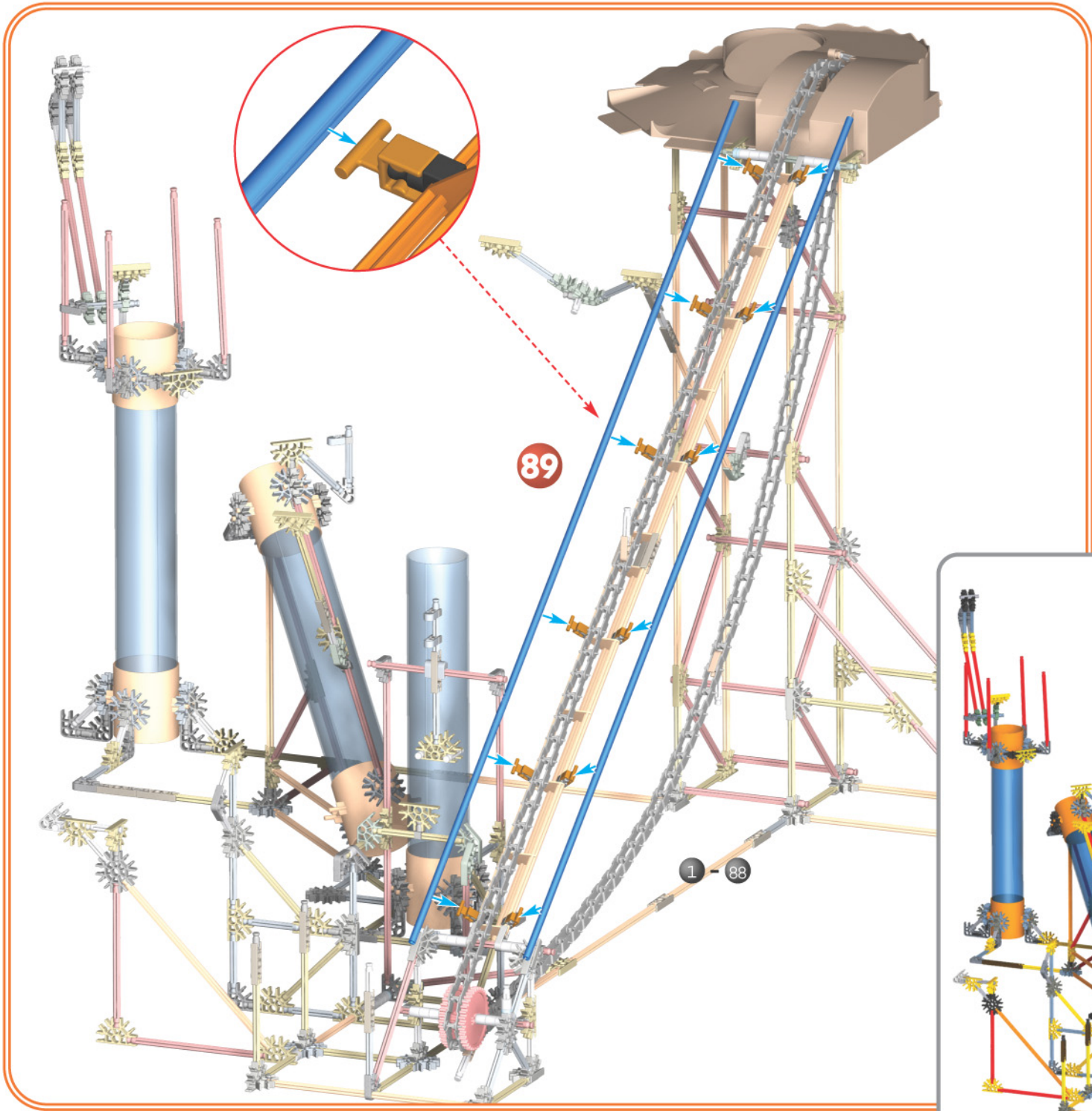

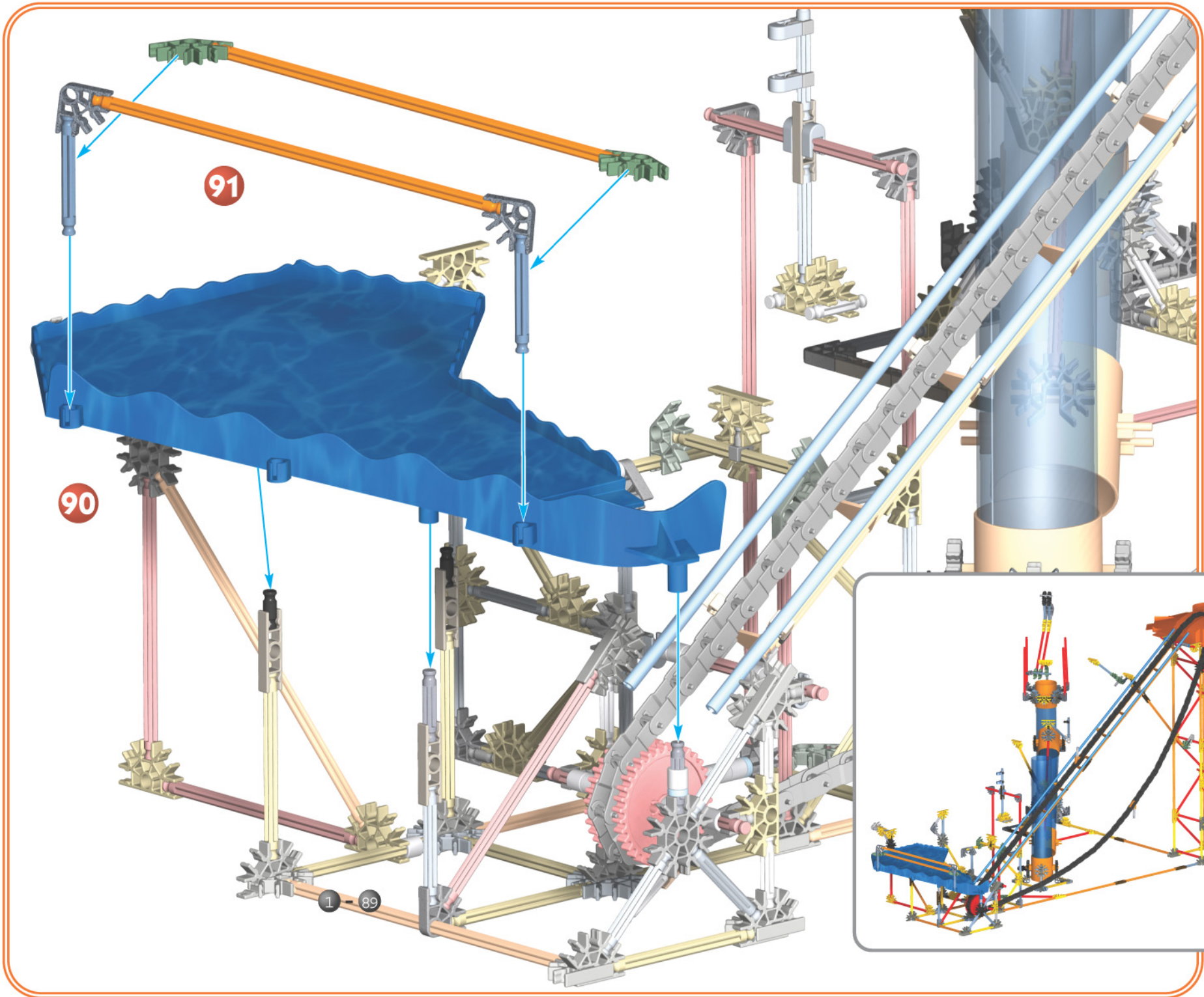

**ENG** See letters underside the Ramps. Use the Ramp Links to join the Ramps together. Attach at the top on model.

**F** Voir les lettres sous les rampes. Utilisez les maillons de la rampe pour joindre les rampes ensemble.

**E** Mira las letras en la parte de abajo de las rampas. Usa los eslabones de las rampas para juntar las rampas.

**D** Richte dich nach den Buchstaben unter den Rampen. Mit den Rampenverbindungsstücken werden die Rampen zusammengebaut.

**NL** Kijk naar de letters onderaan de hellingen. Gebruik de helling links om de hellingen samen te brengen. Verzeker je ervan dat de bulten op de helling links naar boven gericht zijn.

**I** Vedere le lettere sotto le rampe. Usare le connessioni delle rampe per mettere insieme le rampe.

**P** Observa as letras na parte inferior das Rampas. Usa os Elos de União das Rampas para juntares as Rampas em conjunto.

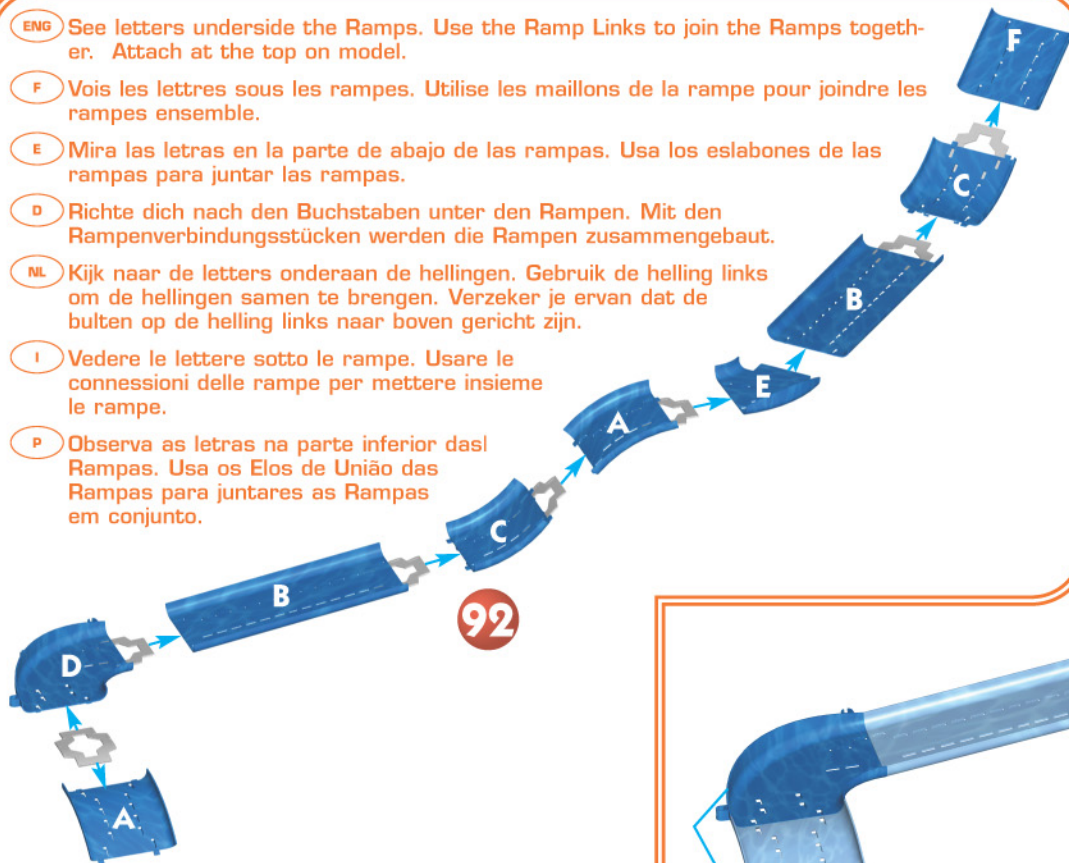

**ENG** This yellow Connector does NOT connect to the Ramp.

**F** Ce connecteur jaune NE se connecte PAS à la rampe.

**E** Este conector amarillo NO se conecta con la rampa.

**D** Dieses gelbe Verbindungsstück wird NICHT mit der Rampe verbunden.

**NL** Dit geel verbindingsstuk wordt NIET vastgemaakt aan de helling.

**I** Questo connettore giallo NON si collega alla rampa.

**P** Este Conector vermelho NÃO se liga à Rampa.

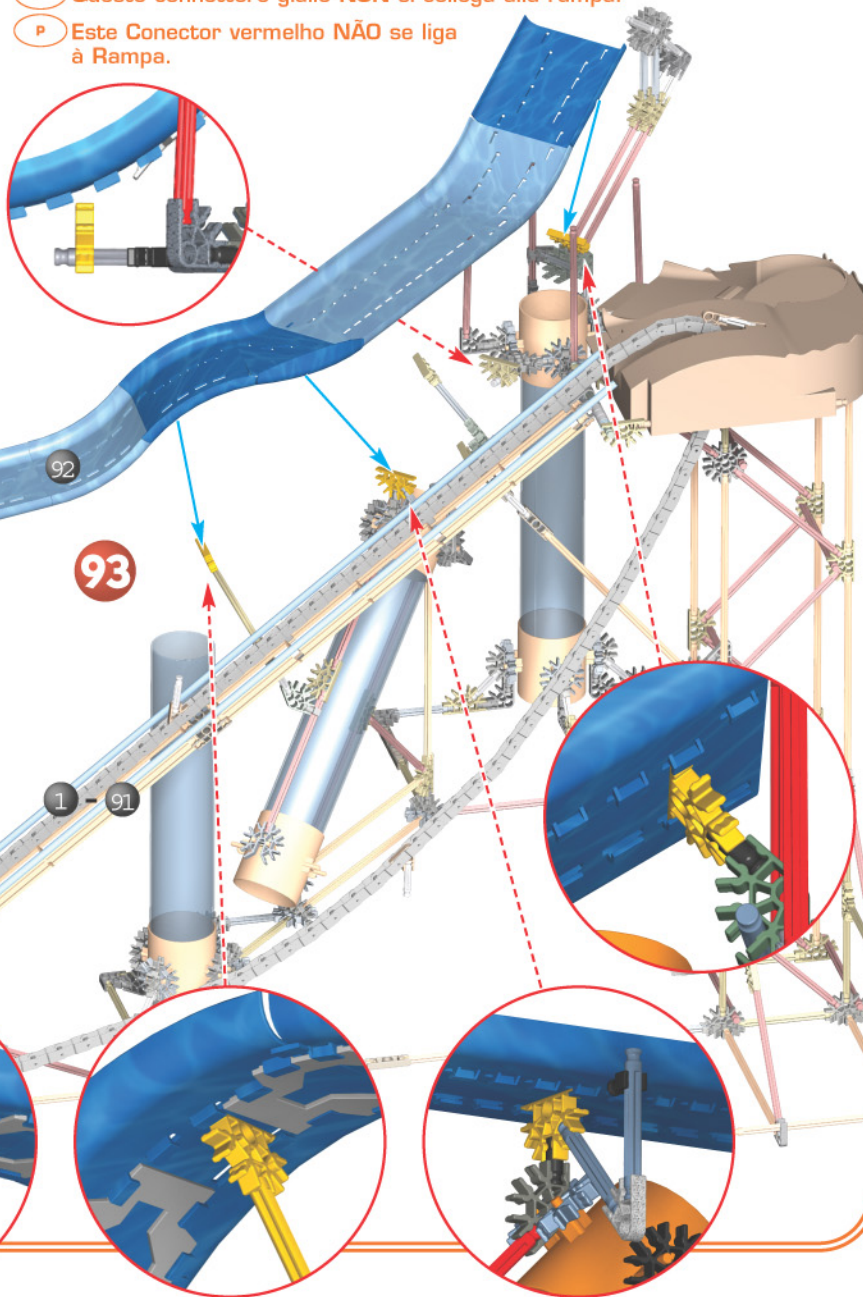

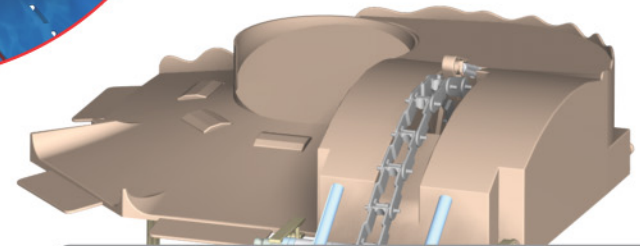
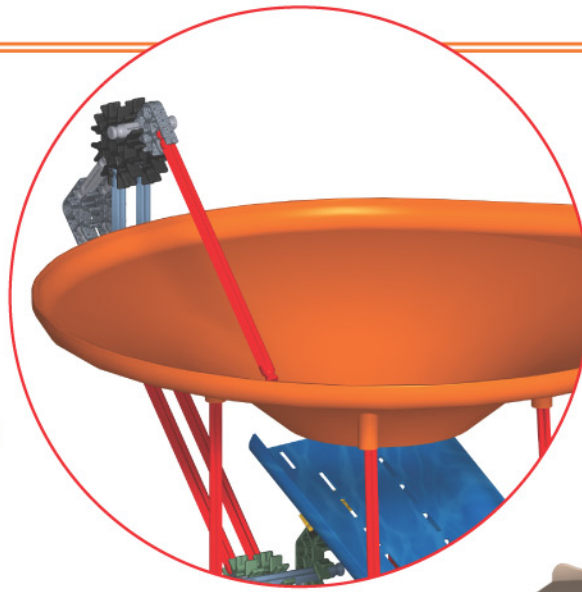
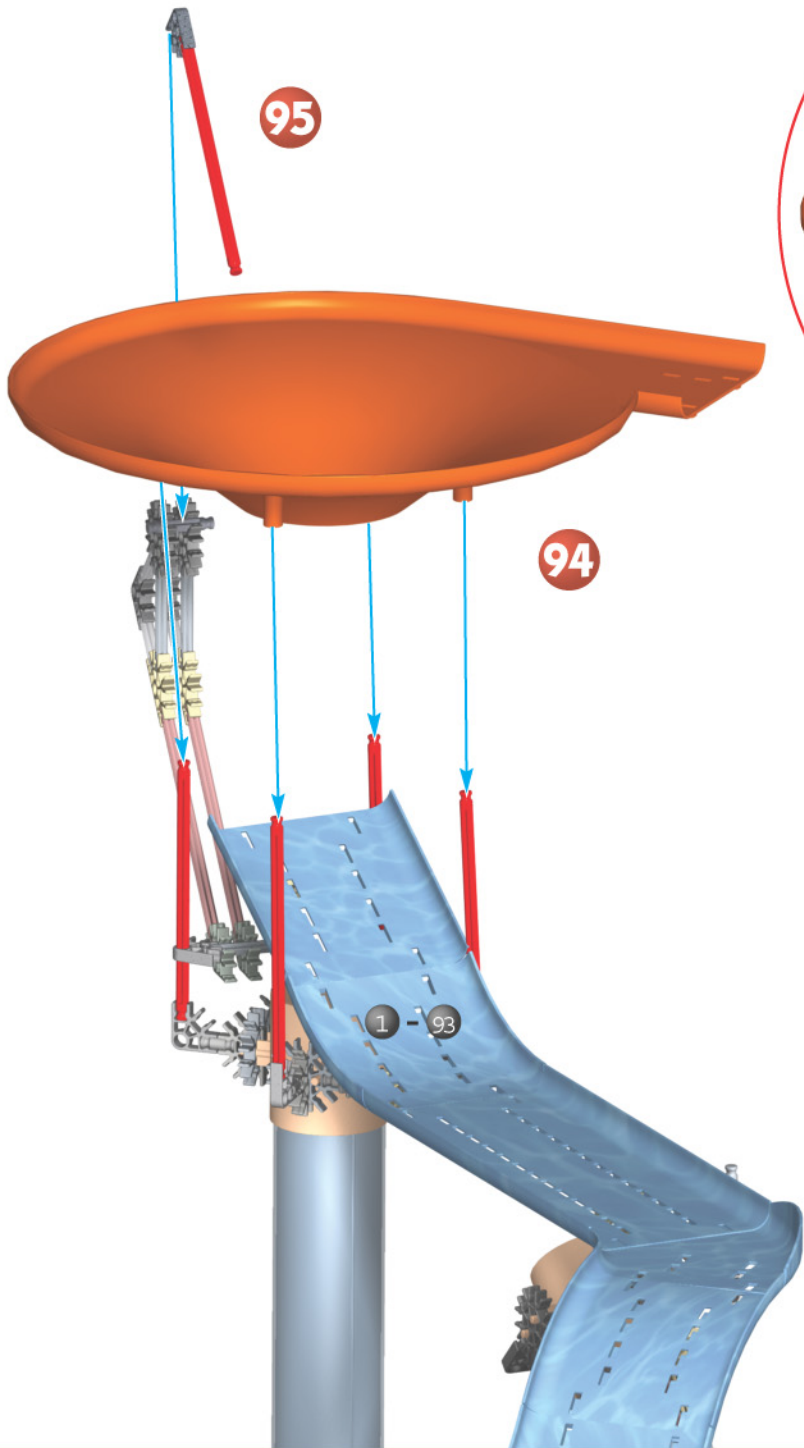

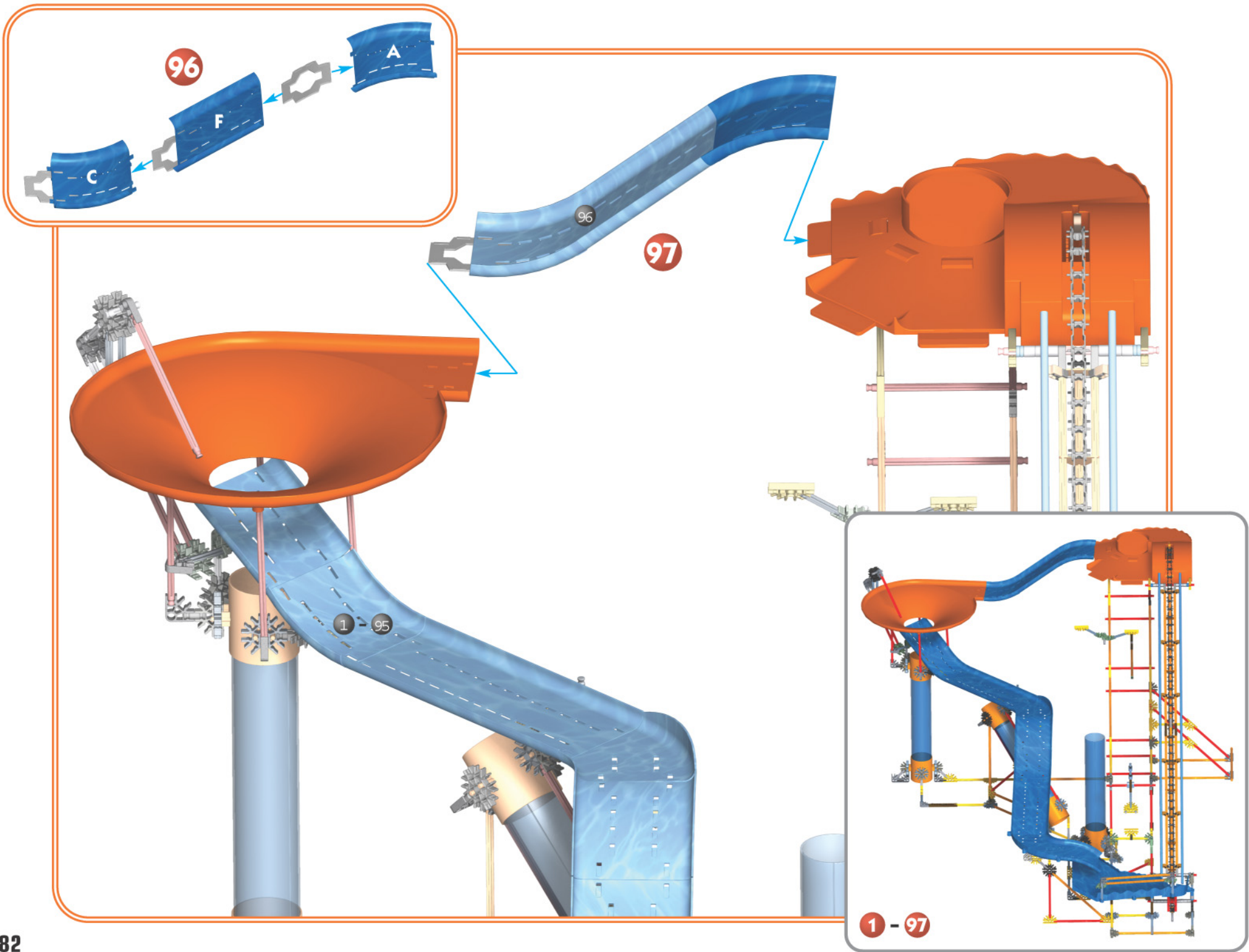

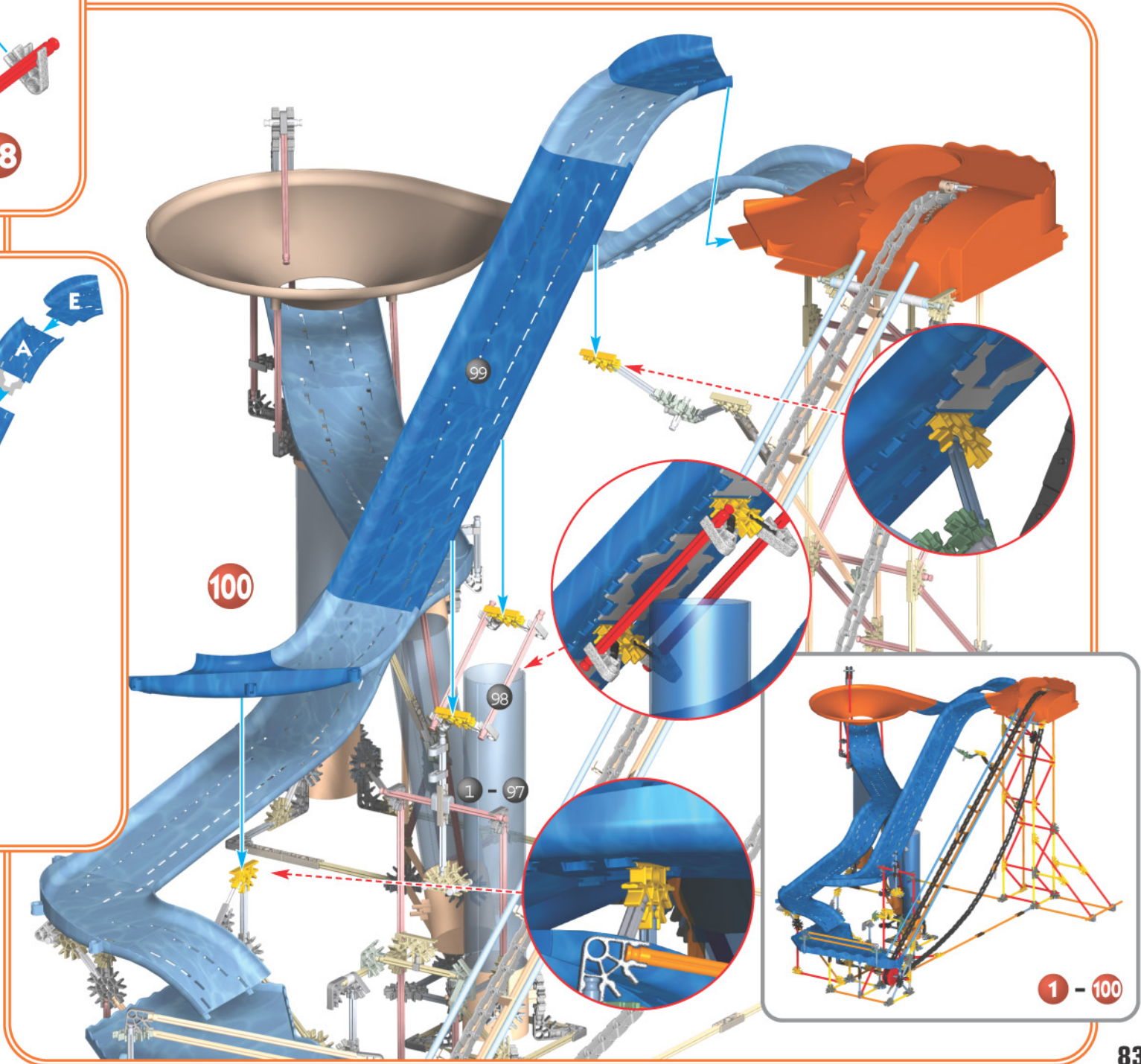
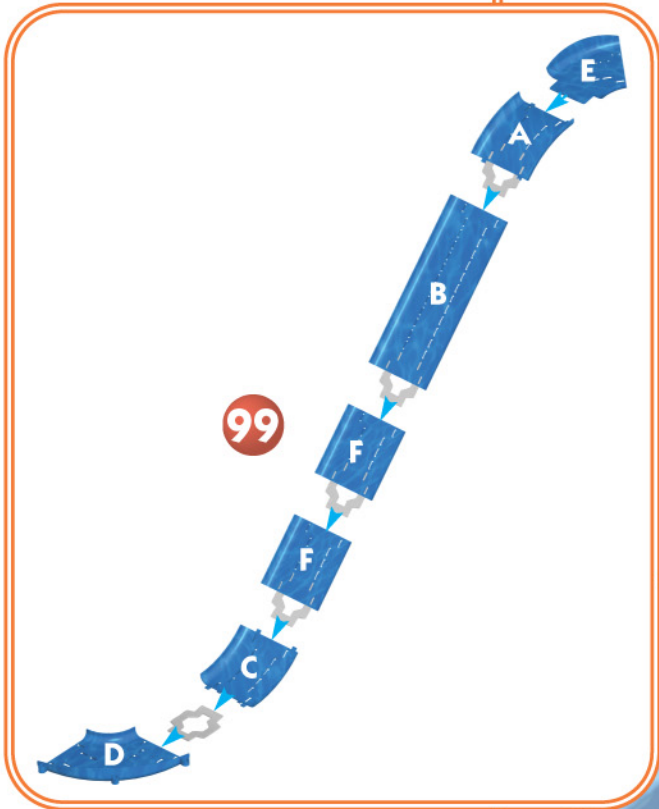
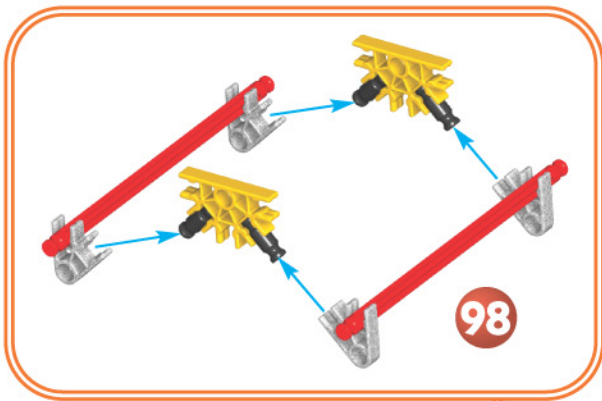

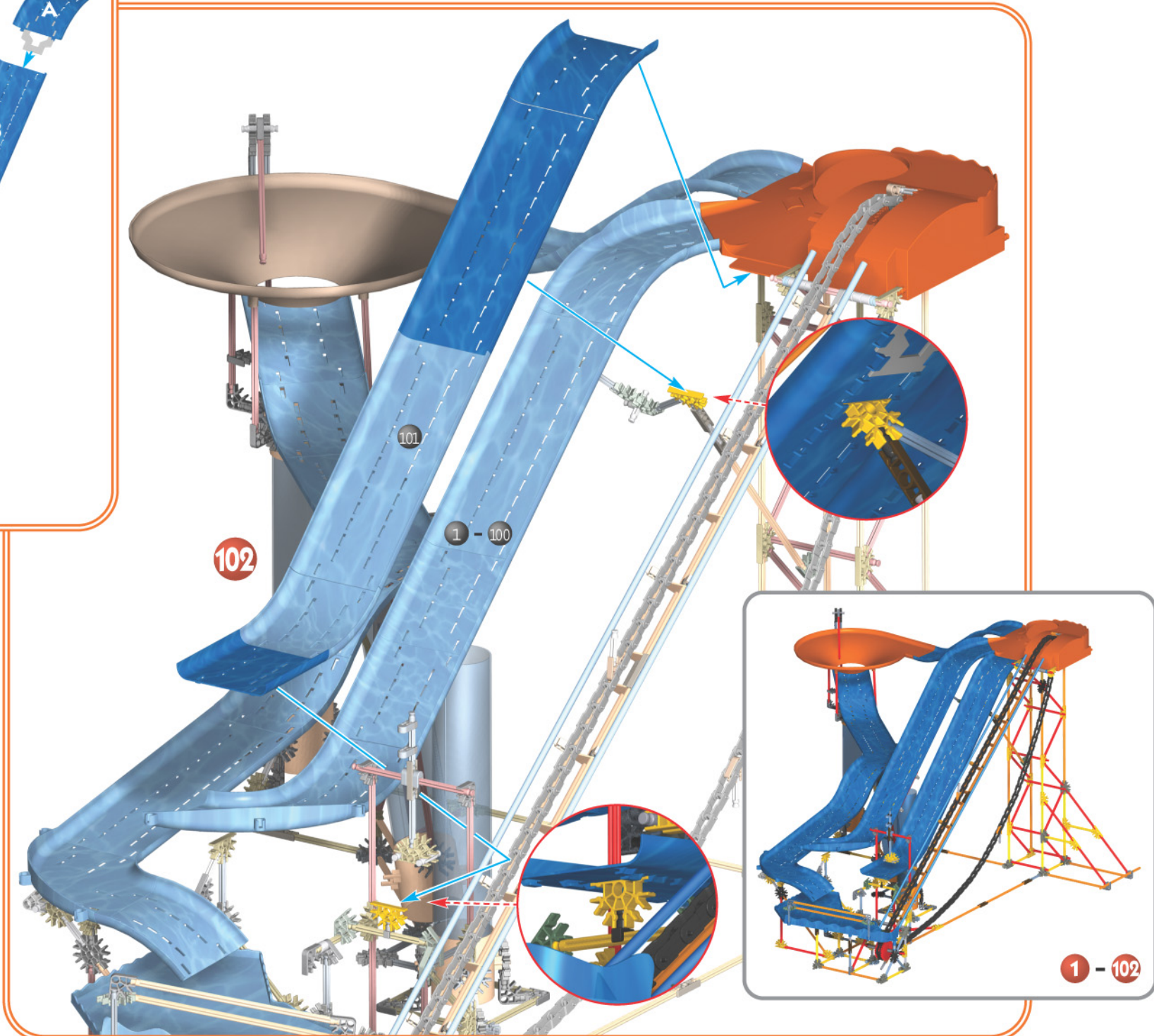
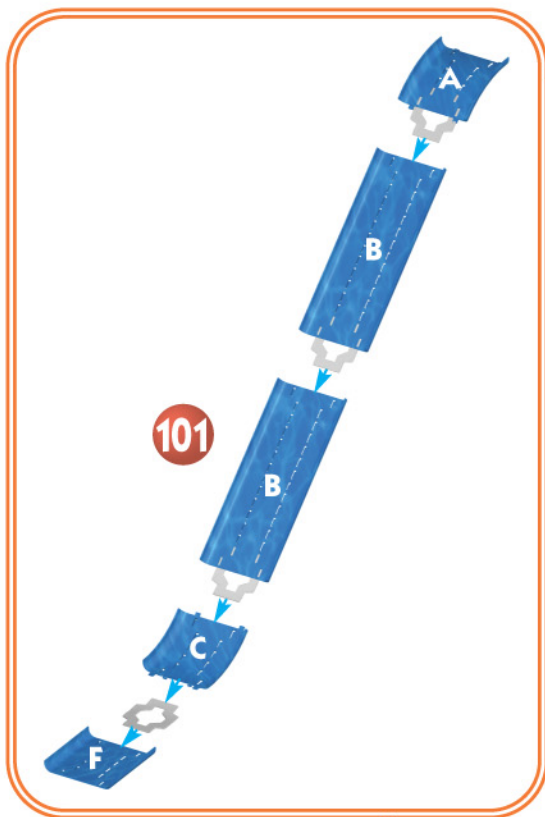

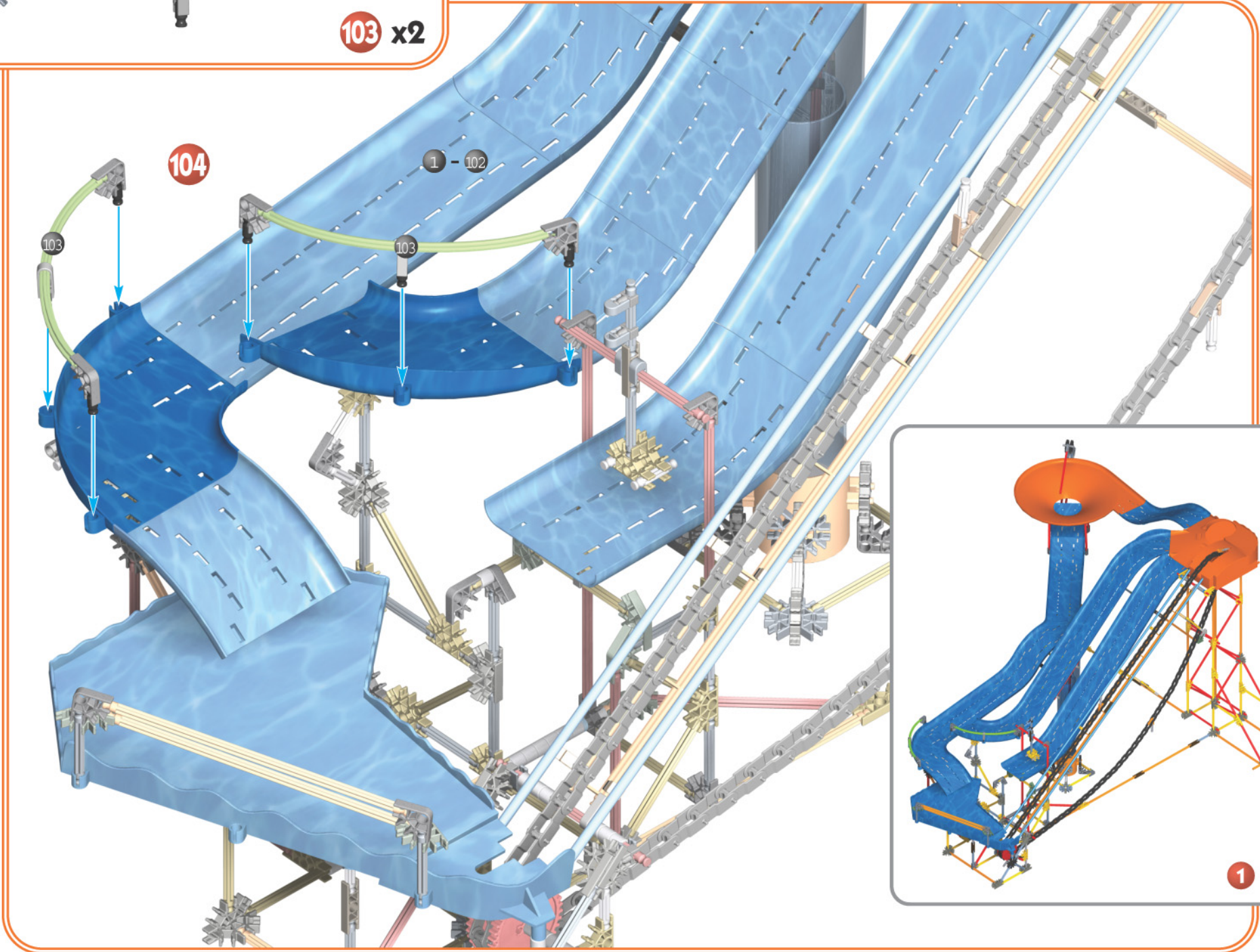
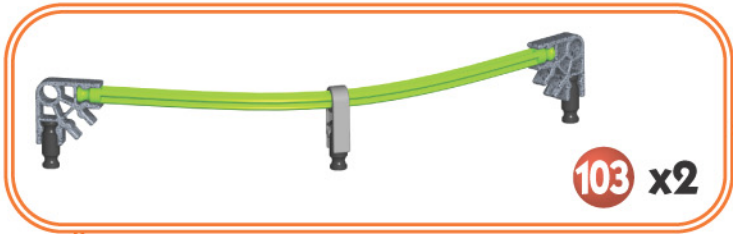

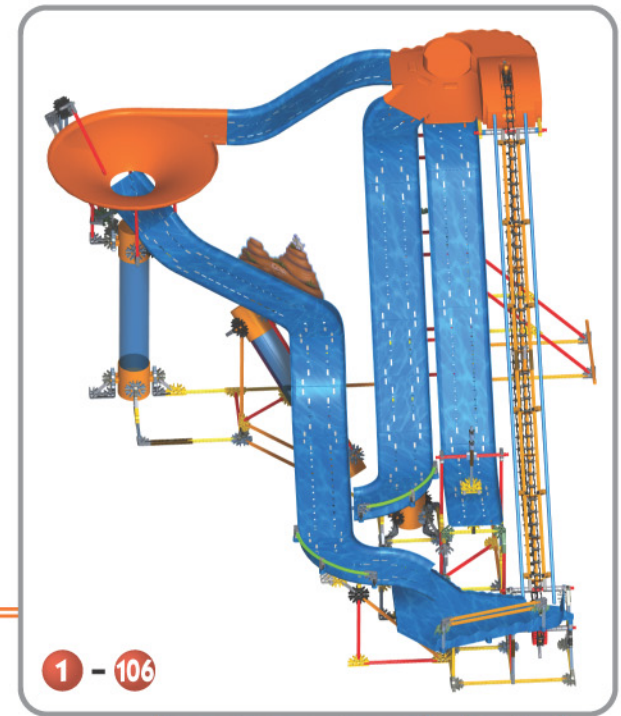
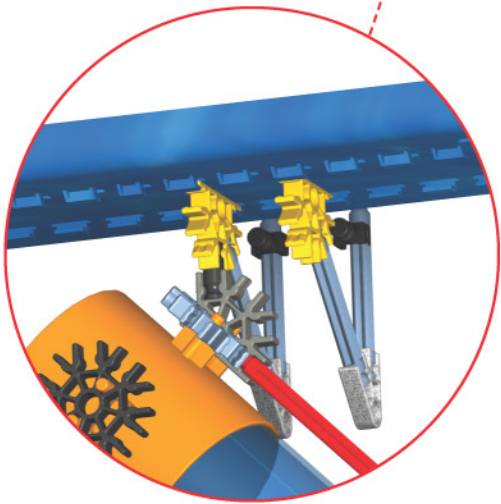
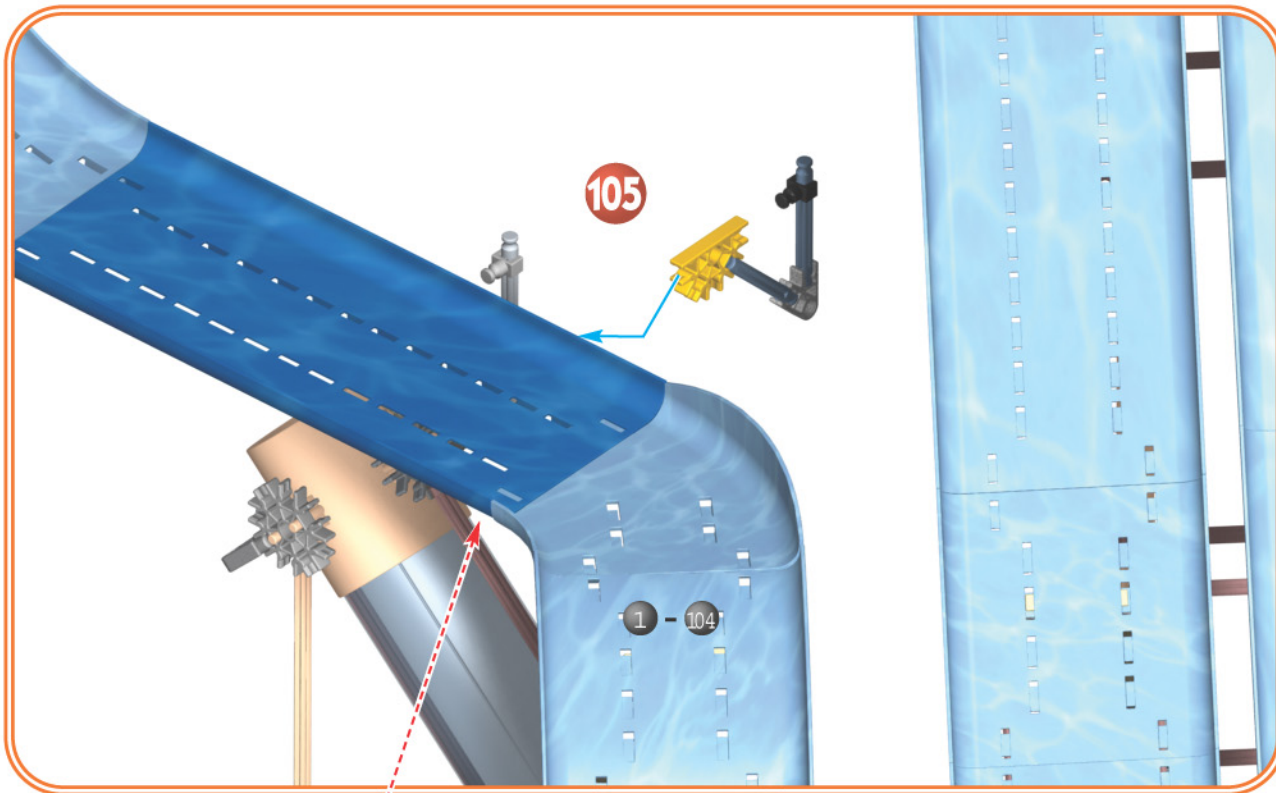

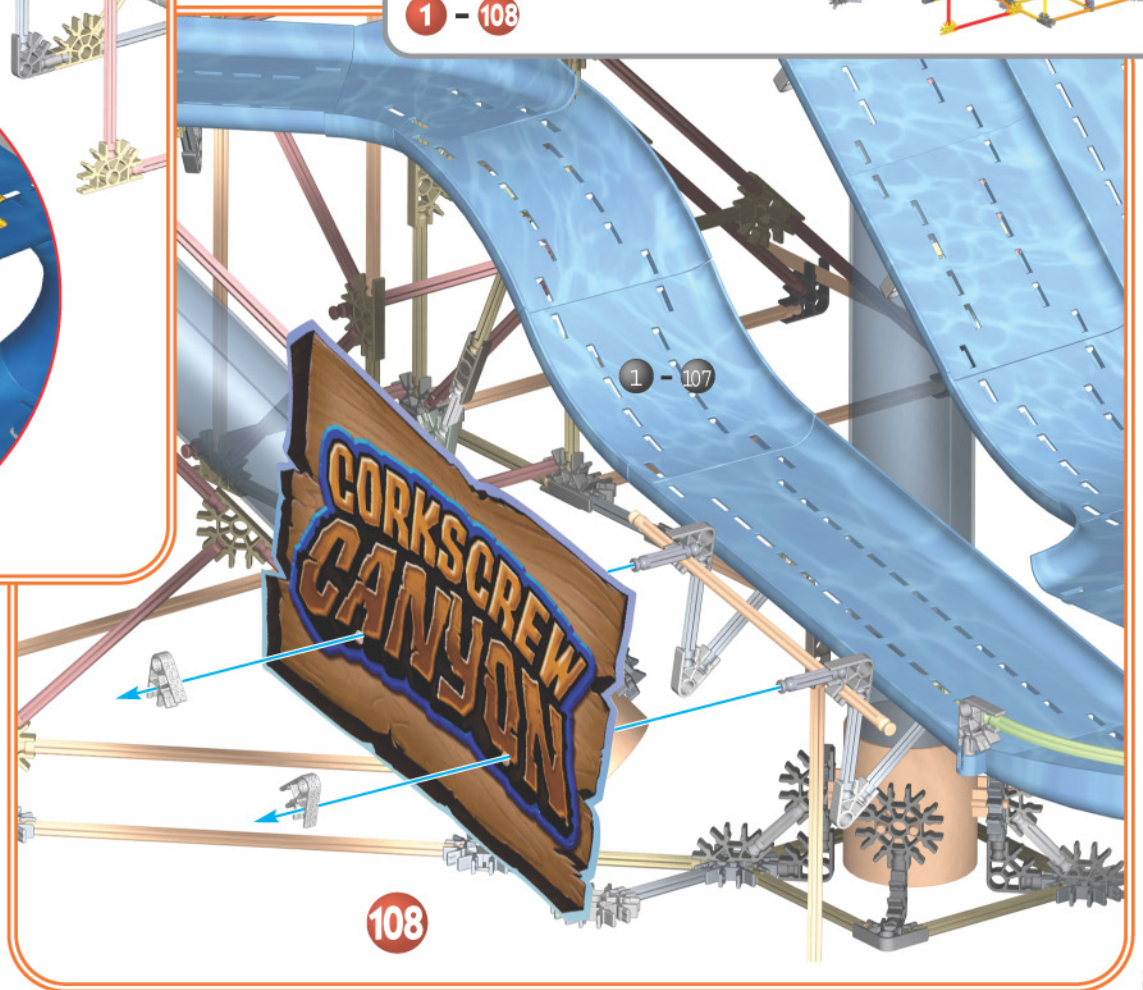
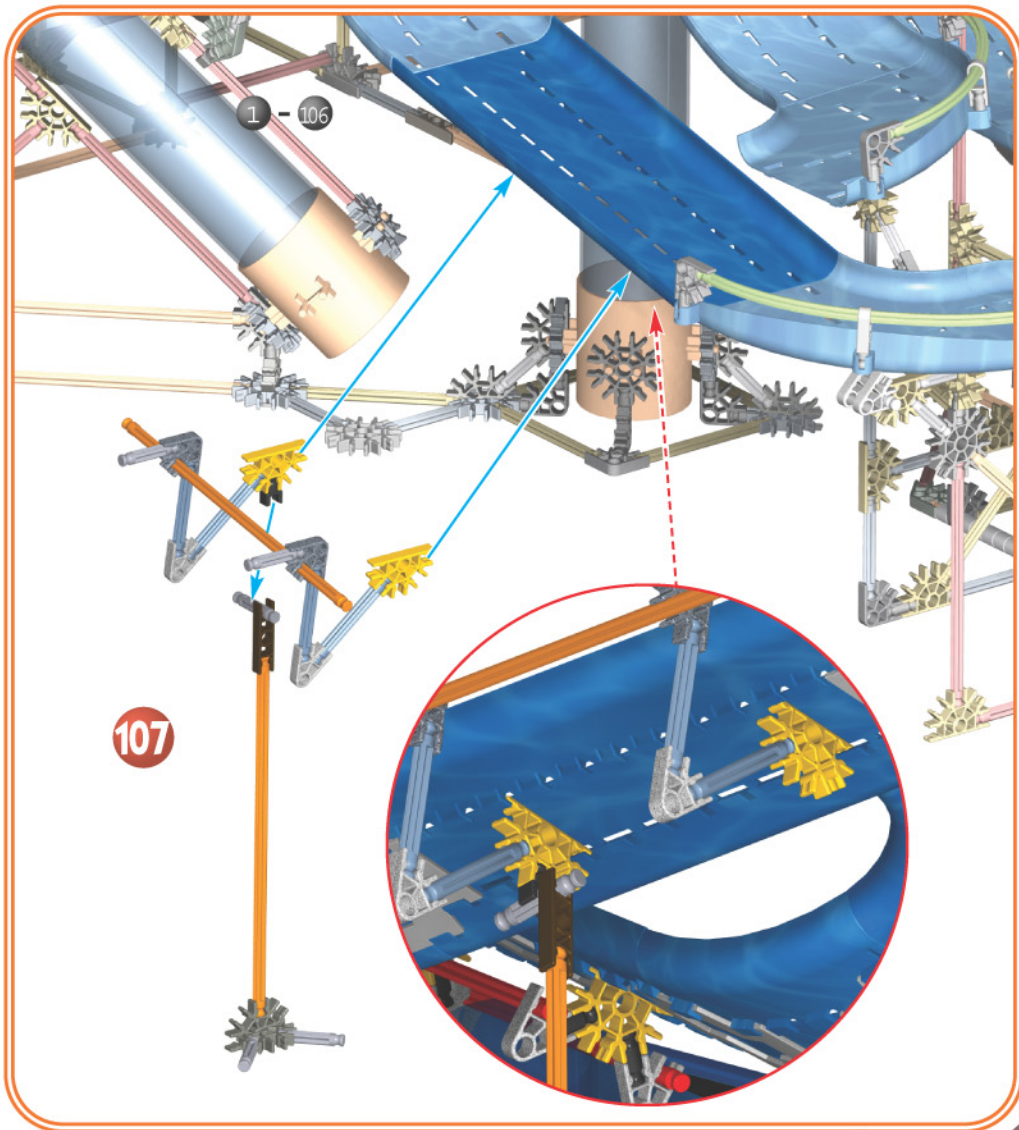

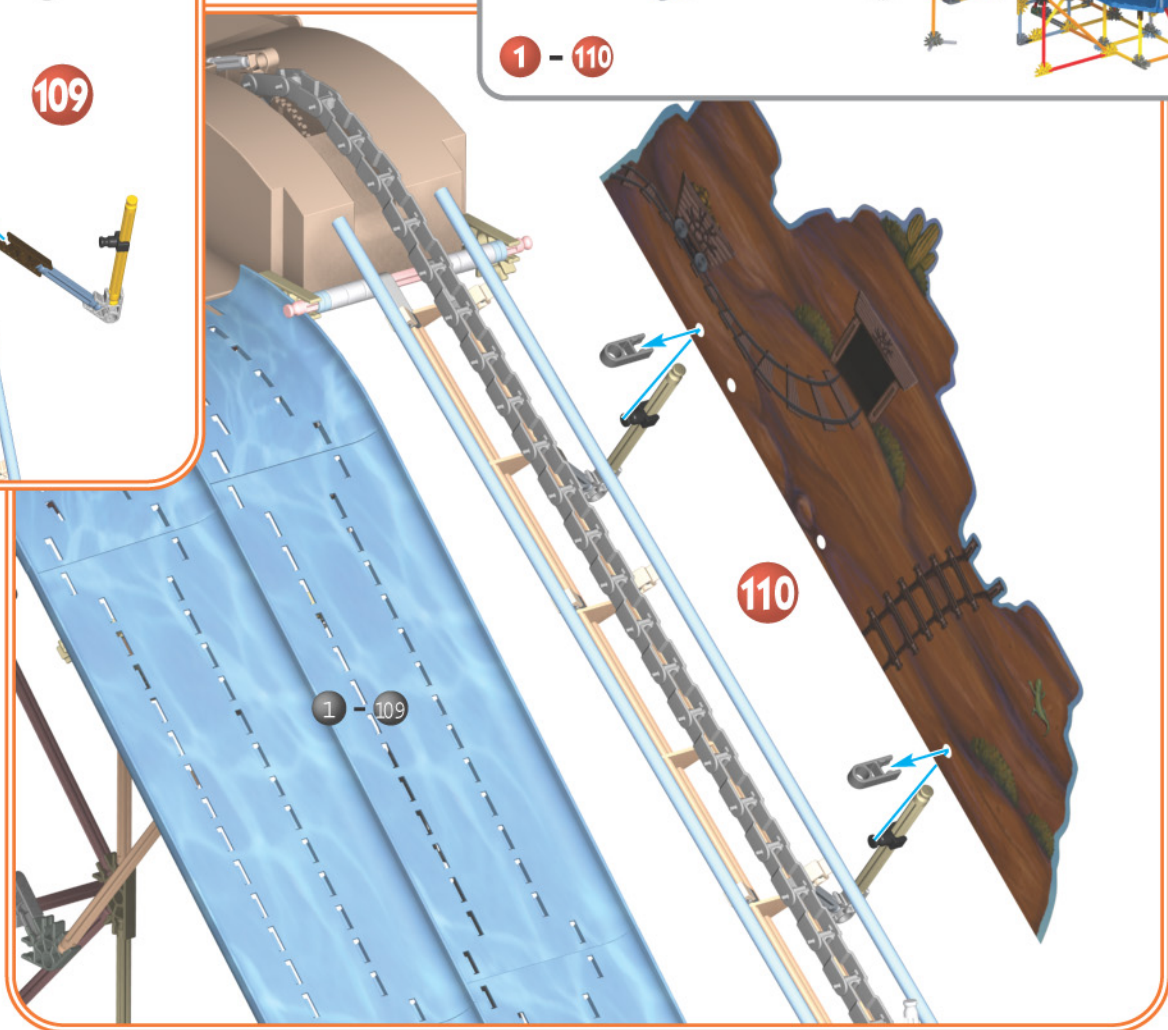
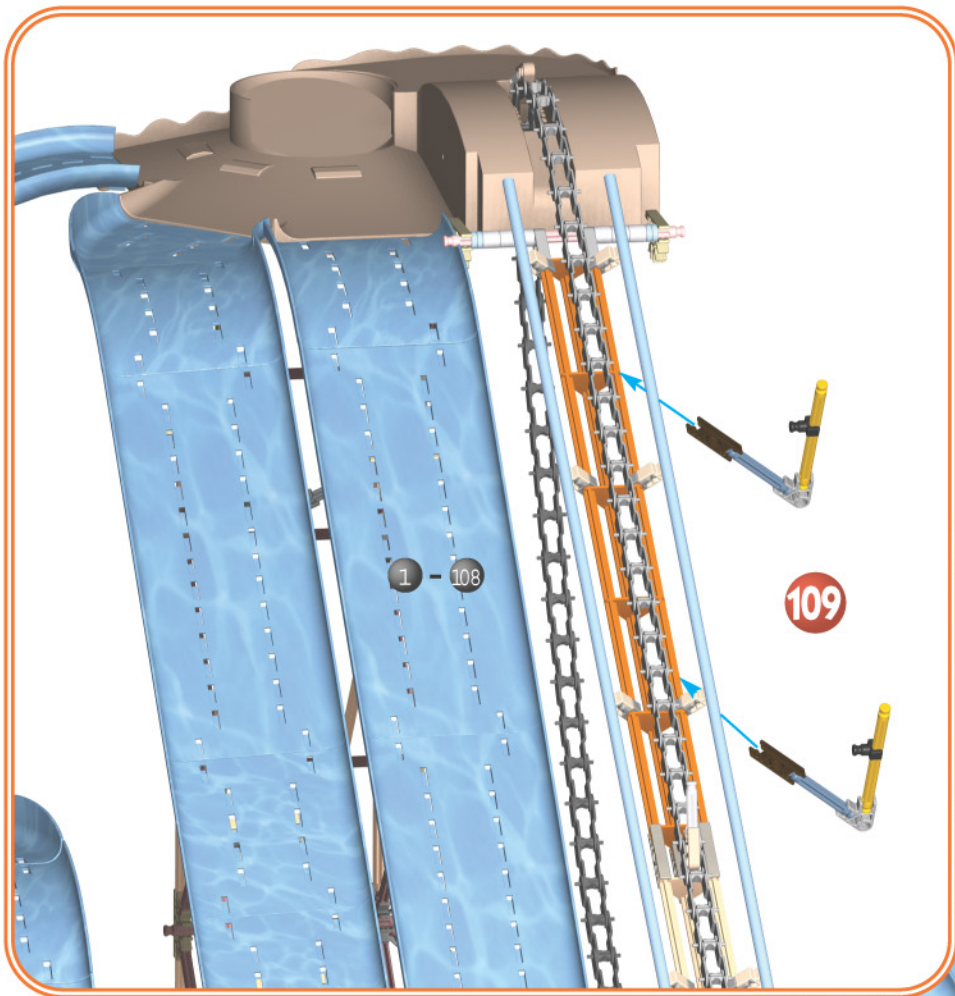

## TIPS & TROUBLESHOOTING

1. If your model is not working, check the instructions to see if the model is built correctly.

- Make sure all the Ramps and Links are completely attached.

2. Motor not working?

- Check to see if you have fresh batteries inserted with the correct polarity.
- If it is still not working, call our Consumer Hotline at 1-800-KID-KNEX (USA and Canada only). See the back cover for other ways to contact K'NEX Industries, Inc.

3. Sound Module not working?

- Make sure the batteries are fresh.

4. To start: Turn the Motor switch on and put the tubers in the pool at the bottom. Then watch the “pick-up” Rods pull the tubers up the hill.

5. If a tuber flips over or out, just put them in the pool again, right side up.

6. Tubers going down the same path?

- Ramp Selector Wheel should be fully pushed in for the Motor to automatically select paths.

7. To manually select a path, pull the Ramp Selector Wheel out and turn it to choose a path.

1.

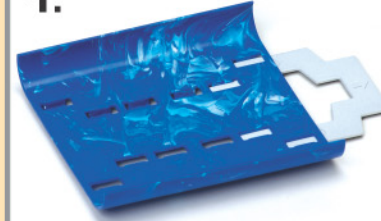

2. & 4.



6.

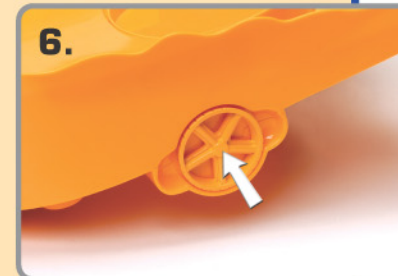

7.



# CORKSCREW CANYON™

**TUBE PARK**  
**PARC AQUATIQUE À CHUTES**

Product and colors may vary.

Models can be built one at a time.

K'NEX is a registered trademark of K'NEX Industries, Inc.  
Printed in China.

Manufactured under U.S. Patents 5,061,219; 5,137,486; 5,199,919; 5,238,438;  
5,346,420; 5,350,331; 5,368,514; 5,421,762; 5,423,707; 5,427,559; 5,518,435;  
D383,509; D388,475; D389,203; D391,843; D391,921; D392,555; D403,722;  
5,913,706; 6,089,941.

Other U.S. and foreign patents pending. Conforms to the  
Requirements of ASTM Standard Consumer Safety  
Specification on Toy Safety, F963-03.

Le produit et les couleurs peuvent varier.

La plupart des modèles peuvent être construits un à la fois.

K'NEX est une marque déposée de K'NEX Industries, Inc.  
Imprimerie aux China.

Fabriqué sous brevets américains 5,061,219; 5,137,486; 5,199,919; 5,238,438;  
5,346,420; 5,350,331; 5,368,514; 5,421,762; 5,423,707; 5,427,559; 5,518,435;  
D383,509; D388,475; D389,203; D391,843; D391,921; D392,555; D403,722;  
5,913,706; 6,089,941.

Autres brevets américains et étrangers en  
instance. Conforme aux spécifications de sécurité  
du consommateur sur la sécurité des jouets de  
la norme ASTM F963-03.



©2005 K'NEX Industries, Inc.  
P.O. Box 700  
Hatfield, PA 19440-0700



**US** Consumer Services  
K'NEX Industries, Inc.  
P.O. Box 700  
Hatfield, PA 19440-0700



**GB** K'NEX  
Newport Consumer Services  
Hasbro UK Ltd., Caswell Way  
Newport, Gwent NP9 0YH



**US** 1-800-KID-KNEX  
US/Canada only (English only)

**GB** 00800-22427276 UK/Ireland only

**F E D NL** 001-215-996-4823



email@knex.com

**Building Tips!**  
Conseils de construction !



**K'NEX.com**