

# K'NEX®

Building Worlds Kids Love®

**6 FOOT  
DOUBLE FERRIS  
WHEEL  
BUILDING SET**

**6 PIEDS LA  
GRANDE ROUE  
JEU DE CONSTRUCTION**

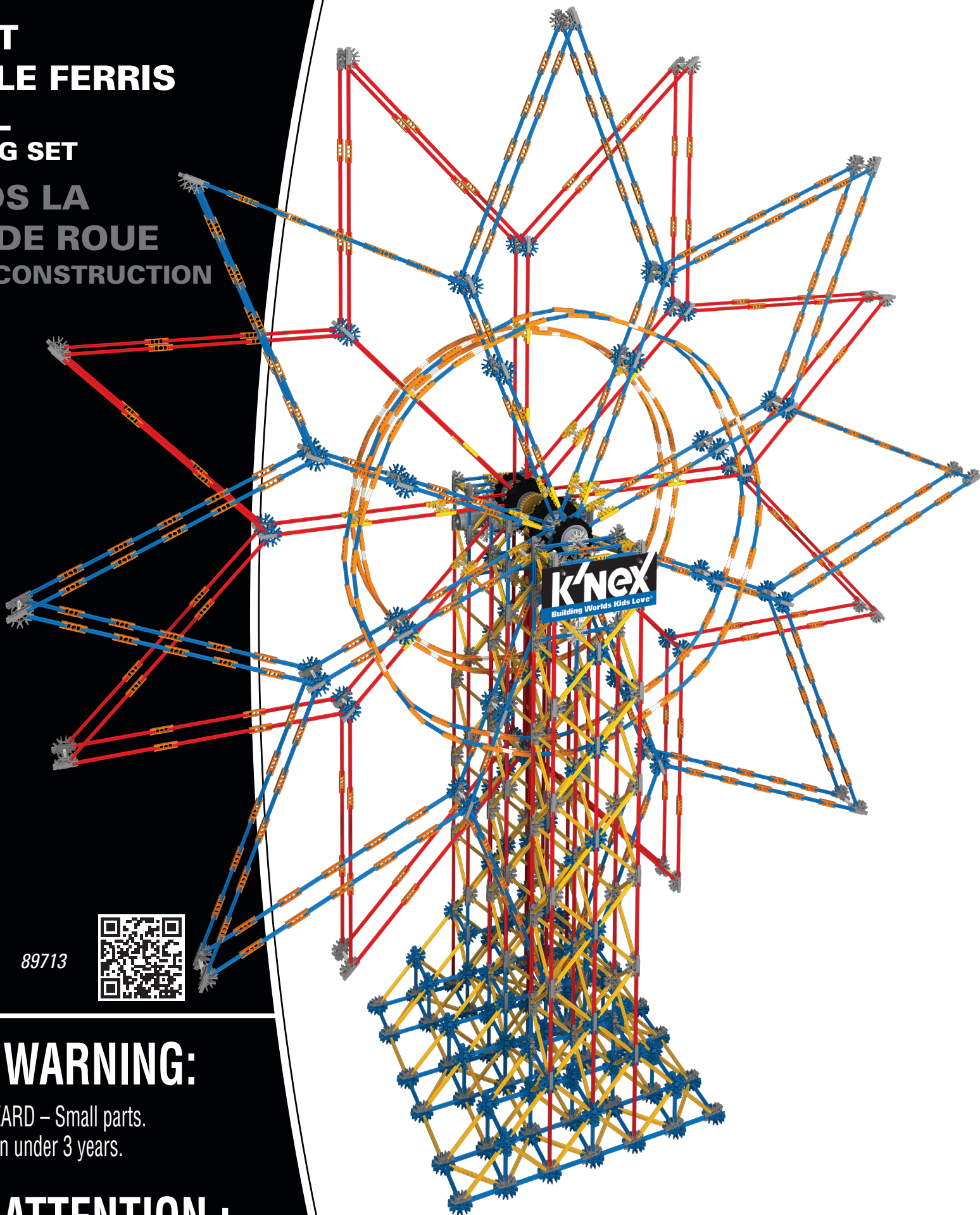

**16+**

89713



**WARNING:**

CHOKING HAZARD – Small parts.  
Not for children under 3 years.



**ATTENTION :**

RISQUE D'ÉTOUFFEMENT – Pièces de petite taille.  
Ne convient pas aux enfants de moins de 3 ans.

# ⚠ CAUTION - ELECTRIC TOY:

**Not recommended for children under 16 years of age. As with all electric products, precautions should be observed during handling and use to prevent electric shock.**

# ⚠ ATTENTION - JOUET ÉLECTRIQUE:

**N'est pas recommandé pour les enfants de moins de 16 ans. Comme pour tous objets électriques, manipuler avec précaution pour éviter tout danger d'électrocution.**

- EN** Keep this important information for future reference.
- FR** Gardez précieusement cette notice pour y référer ultérieurement.
- ES** Guarde esta información importante para futuras referencias.
- DE** Informationen für später aufbewahren.
- IT** Conservare queste importanti informazioni per riferimento futuro.
- PT** Manter esta informação importante para referência futura.
- NL** Bewaar deze belangrijke informatie, zodat u deze in de toekomst opnieuw kunt raadplegen.

**⚠ WARNING: CHOKING HAZARD – Small parts. Not for children under 3 years.**

**ATTENTION : RISQUE D'ÉTOUFFEMENT – Pièces de petite taille. Ne convient pas aux enfants de moins de 3 ans.**

**ADVERTENCIA: PELIGRO DE ASFIXIA – Piezas pequeñas. No para niños menores de 3 años.**

**ACHTUNG: ERSTICKUNGSGEFAHR – Kleinteile. Nicht geeignet für Kinder unter 3 Jahren.**

**AVISO: PERICOLO DI SOFFOCARE – Pezzi piccoli. Non adatto per bambini sotto 3 anni.**

**AVISO: PERIGO DE SUFOCAÇÃO – Peças pequenas. Não se destina a crianças com menos de 3 anos de idade.**

**WAARSCHUWING: VERSTIKKINGSGEVAAR – Kleine onderdelen. Niet geschikt voor kinderen onder 3.**

(EN)

- Do not trip on the cord.
- Be sure to save these instructions.
- Adapter must be plugged into 120 V (in US) / 240 V (in EU) outlet only.
- Before you use your K'NEX Motor Pack, read all instructions carefully.
- Never put your fingers in moving Gears; you will stop the motor and could injure yourself.
- Examine your Power Supply components regularly, looking for damaged parts, damage to cord or plug, or possible overheating.
- Do not use Power Supply until damage has been repaired.
- FOR INDOOR USE ONLY.
- Toy should not be connected to more than the recommended number of power supplies.
- The transformer is not intended for children under 3 years old. The transformer is not a toy.
- The toy must only be used with the recommended transformer.
- To prevent electric shock do not immerse in water, wipe clean with damp cloth.
- Electrical components can 'short-out' if exposed to water or moisture.
- Keep the electrical components dry.
- Always store in a dry area. Do not use when wet.
- Electrocution could occur when handling the plug with wet hands.
- Do not handle plug with wet hands. **WARNING:** Failure to comply with or observe all assembly, safety, and operation instructions and warnings regarding the use of this product may result in serious bodily injury.
- Unplug power cord if liquid or drink has spilled into the unit.
- To stop the movement of your motorized model, unplug the Adapter from the outlet.
- Never attempt to stop any moving piece; you may work the worm gear loose from the motor.
- INPUT: 120V AC 60Hz 6W (US) / 240V AC 50Hz 6W (UK) OUTPUT: 12V DC 500mA 6W

(FR)

- Ne pas trébucher sur le cordon.
- Conservé soigneusement les instructions.

## Important Building Tip:

- The wheel must be evenly balanced to turn properly. If the Ferris Wheel does not run smoothly, check to make sure the parts are firmly connected and that the shape of the wheels is symmetrical.

## Conseil important :

- Pour bien tourner, il faut que la roue soit également équilibrée. Si la grande roue ne tourne pas bien, vérifiez que les pièces sont bien connectées les unes aux autres et que la forme des roues est symétrique.

**WARNING:** Not suitable for children under 18 months. Long cord/Long chain. Strangulation hazard.

**AVERTISSEMENT :** Ne convient pas aux enfants de moins de 18 mois. Longue corde/Longue chaîne. Risque d'étranglement.

**ADVERTENCIA:** No adecuado para niños menores de 18 meses. Cable largo/cadena larga. Peligro de estrangulamiento.

**ACHTUNG:** Nicht geeignet für Kinder unter 18 Monate. Lange Schnur / Lange Kette. Strangulierungsgefahr.

**AVISO:** Non adatto a bambini di età inferiore a 18 mesi. Cavo lungo / lunga catena. Rischio di strangolamento.

**AVISO:** Não recomendado para menores de 18 meses. Cabo longo / cadeia longa. Perigo de estrangulamento.

**WAARSCHUWING:** Niet geschikt voor kinderen onder de 18 maanden. Lang snoer / lange keten. Gevaar voor worging.



The wheeled bin indicates this product cannot be disposed of with household waste due to presence of hazardous substances.  
To protect human health and environment, check your local authority for recycling advice and facilities (2012/19/EU, Europe only).



Le symbole "poubelle à roulettes" indique que ce produit ne peut pas être éliminé avec les déchets ménagers en raison de la présence de substances dangereuses. Afin de protéger votre santé et l'environnement, veuillez vous adresser aux autorités locales afin d'obtenir des conseils sur le recyclage et la localisation des installations adaptées (2012/19/EU, Europe uniquement).



El contenedor de basura indica que este producto no puede desecharse con la basura doméstica debido a la presencia de sustancias peligrosas.  
Para proteger la salud humana y el medio ambiente consultar con la agencia local para el consejo y las facilidades de reciclaje (2012/19/EU, solo Europa).



Der Abfallbehälter zeigt an, dass dieses Produkt aufgrund von Gefahrstoffen nicht im normalen Hausmüll entsorgt werden kann. Zum Schutz von Gesundheit und Umwelt kontaktieren bitte deine lokale Behörden für Recyclingtipp und -einrichtungen (2012/19/EU, nur Europa).



Il bidone della spazzatura indica che questo prodotto non si può buttare via con i rifiuti domestici.  
A causa della presenza di sostanze pericolose, per proteggere la salute e l'ambiente, devi consultare con la tua autorità locale per consigli e impianti di riciclaggio (2012/19/EU, solo in Europa).



O cabote do lixo indica que este produto não pode ser descartado junto com o lixo doméstico devido à presença de substâncias perigosas.  
Para proteger a saúde humana e o meio ambiente verifique a sua autoridade local para reciclagem conselho e instalações (2012/19/EU, somente na Europa).



Het pictogram van een verwijfbare vuilnisbak geeft weer dat dit product niet samen met het gewone huus-, tuin- en keukenafval mag worden weggegooid, omdat het gevaarlijke substanties bevat. Bescherm gezondheid en milieu en vraag advies aan de plaatselijke afvalverwerkingsdienst over hoe en waar u producten kunt recylen (2012/19/EU, alleen Europa).

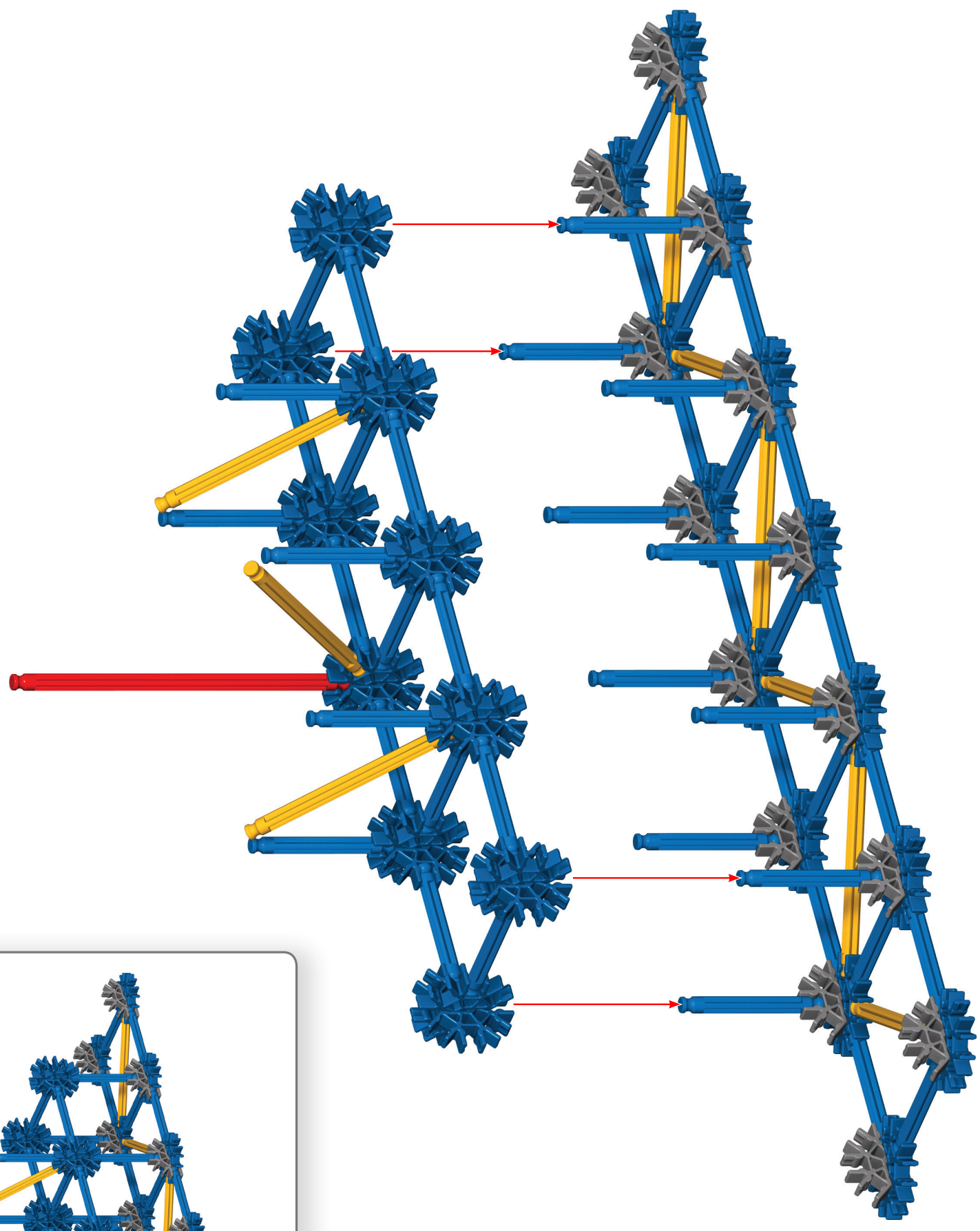
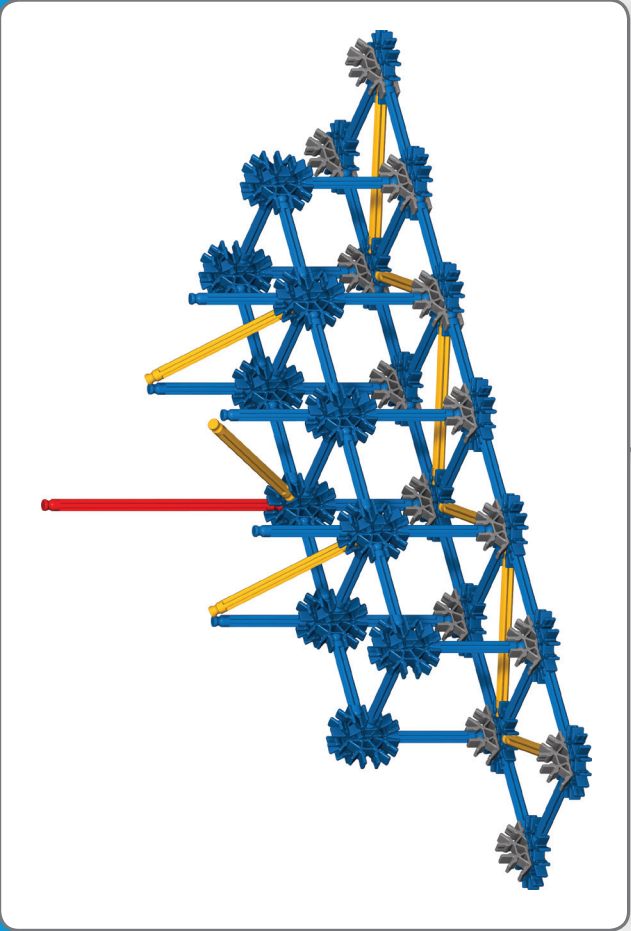

**(EN) Important Tip:**  
 First put together all the 2 Connector parts that are listed below before you start to build the section on this page.

**(FR) Conseil important :**  
 Assemblez d'abord tous les éléments à 2 connecteurs qui sont indiqués ci-dessous avant de vous mettre à construire la section figurant sur cette page.

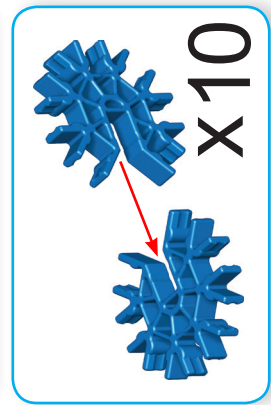
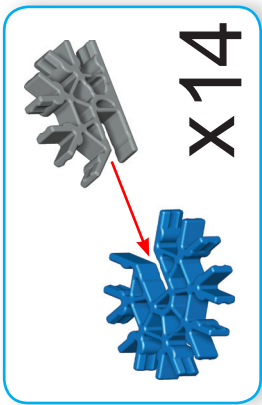

A

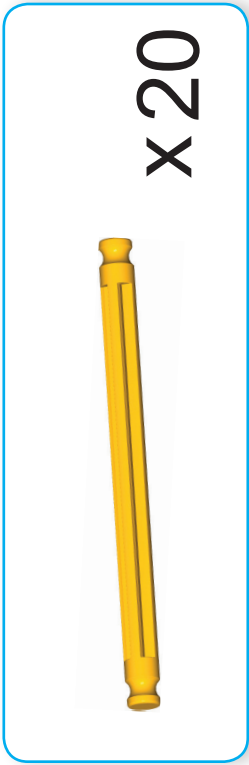
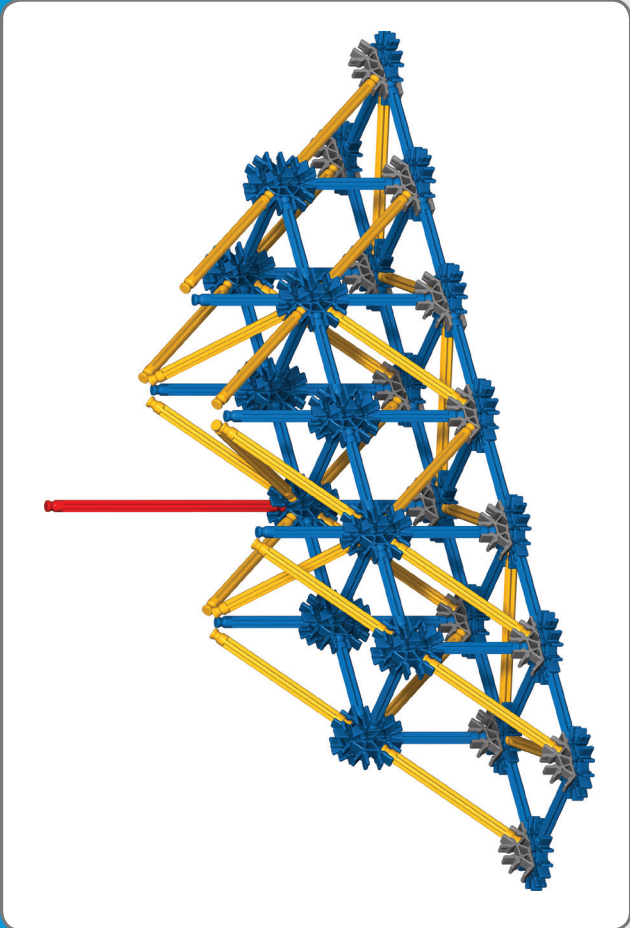

(EN) Important Tip:  
Now add the yellow Rods.

(FR) Conseil important :  
Ajoutez maintenant les tiges jaunes.

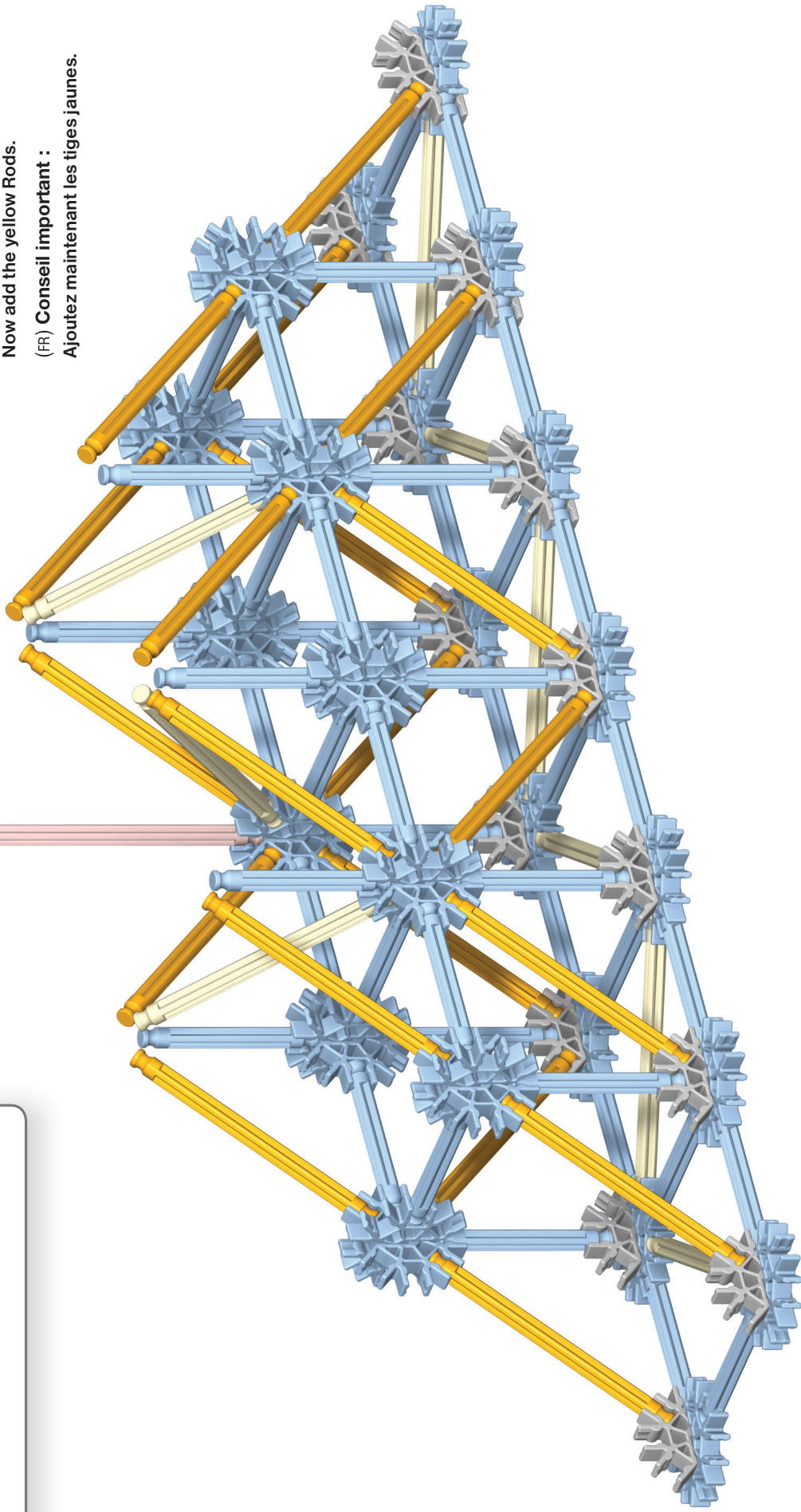

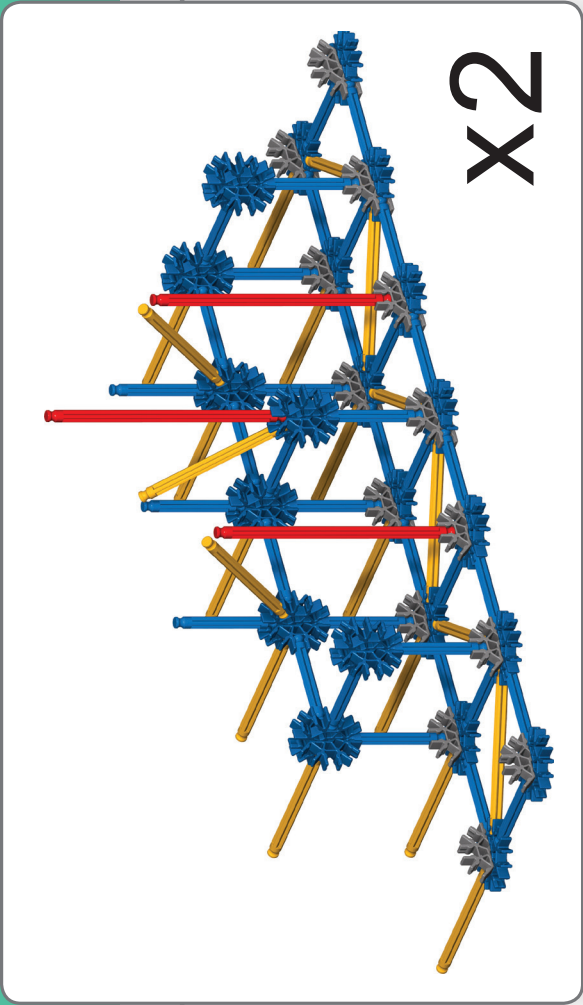

x2

**(EN) Important Tip:**  
 First put together all the 2 Connector parts that are listed below before you start to build the section on this page.

**(FR) Conseil important :**

Assemblez d'abord tous les éléments à 2 connecteurs qui sont indiqués ci-dessous avant de vous mettre à construire la section figurant sur cette page.

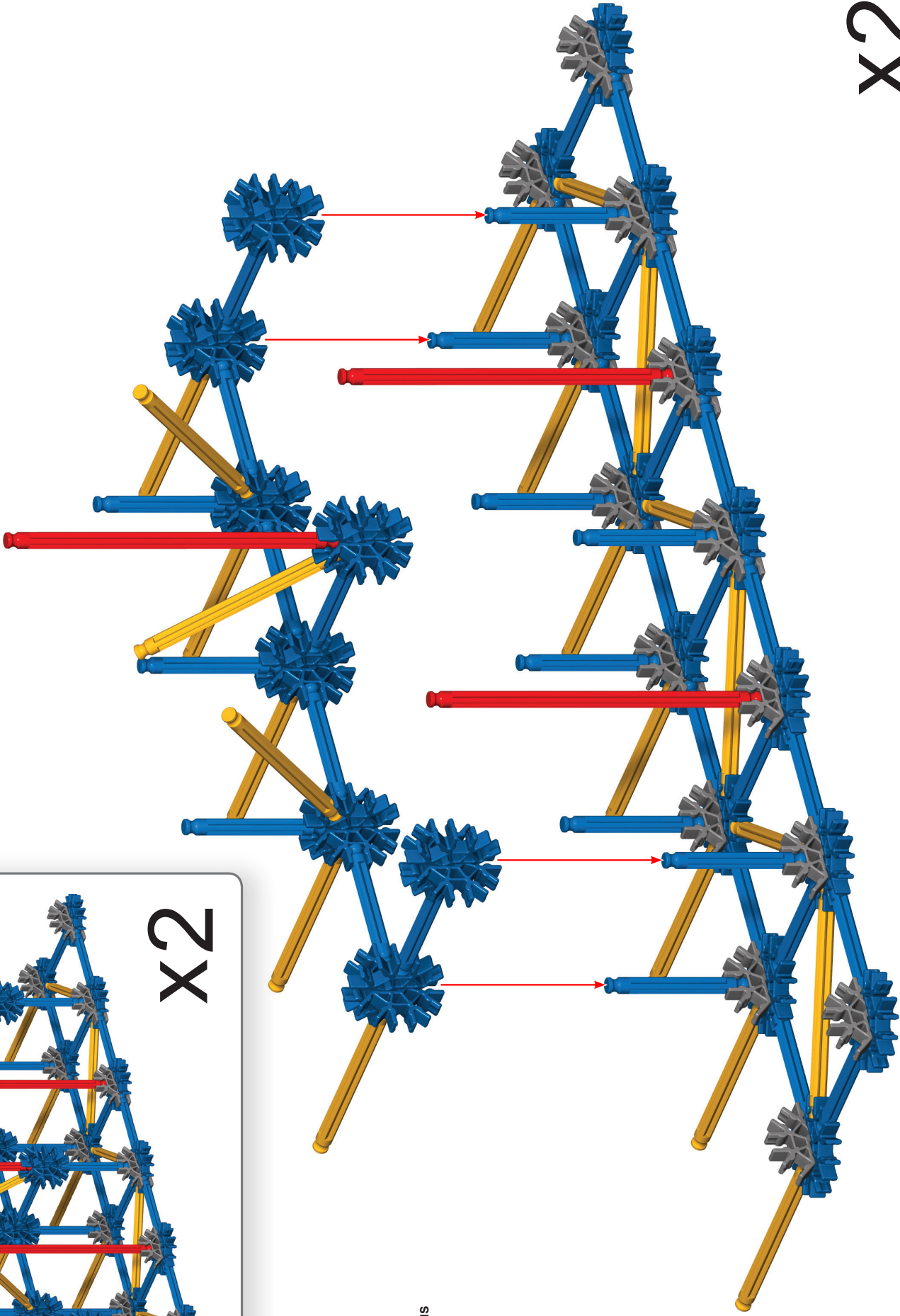
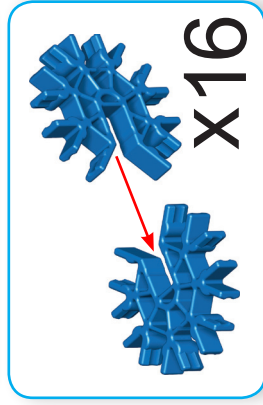
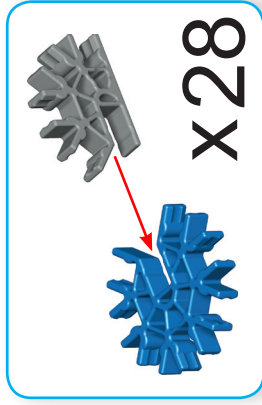

x2

B

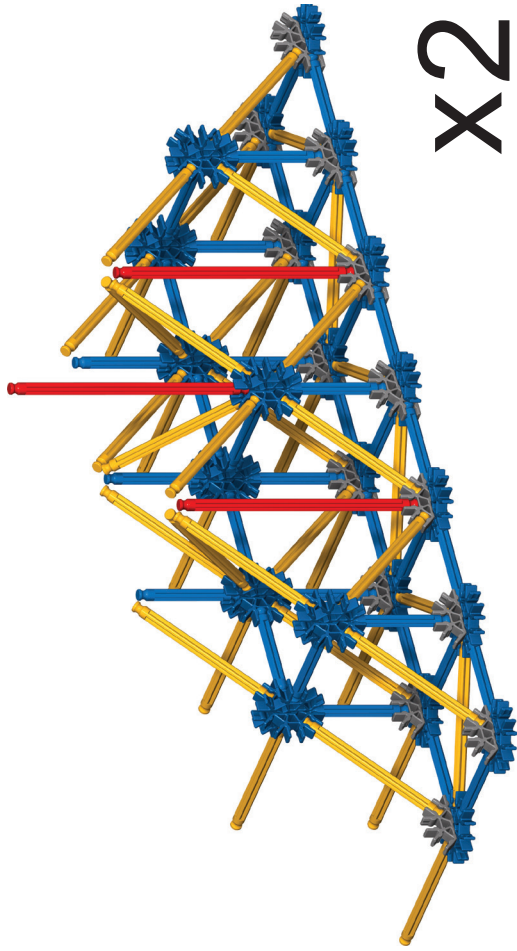

X2



X20

(EN) Important Tip:

Now add the yellow Rods.

(FR) Conseil important :

Ajoutez maintenant les tiges jaunes.

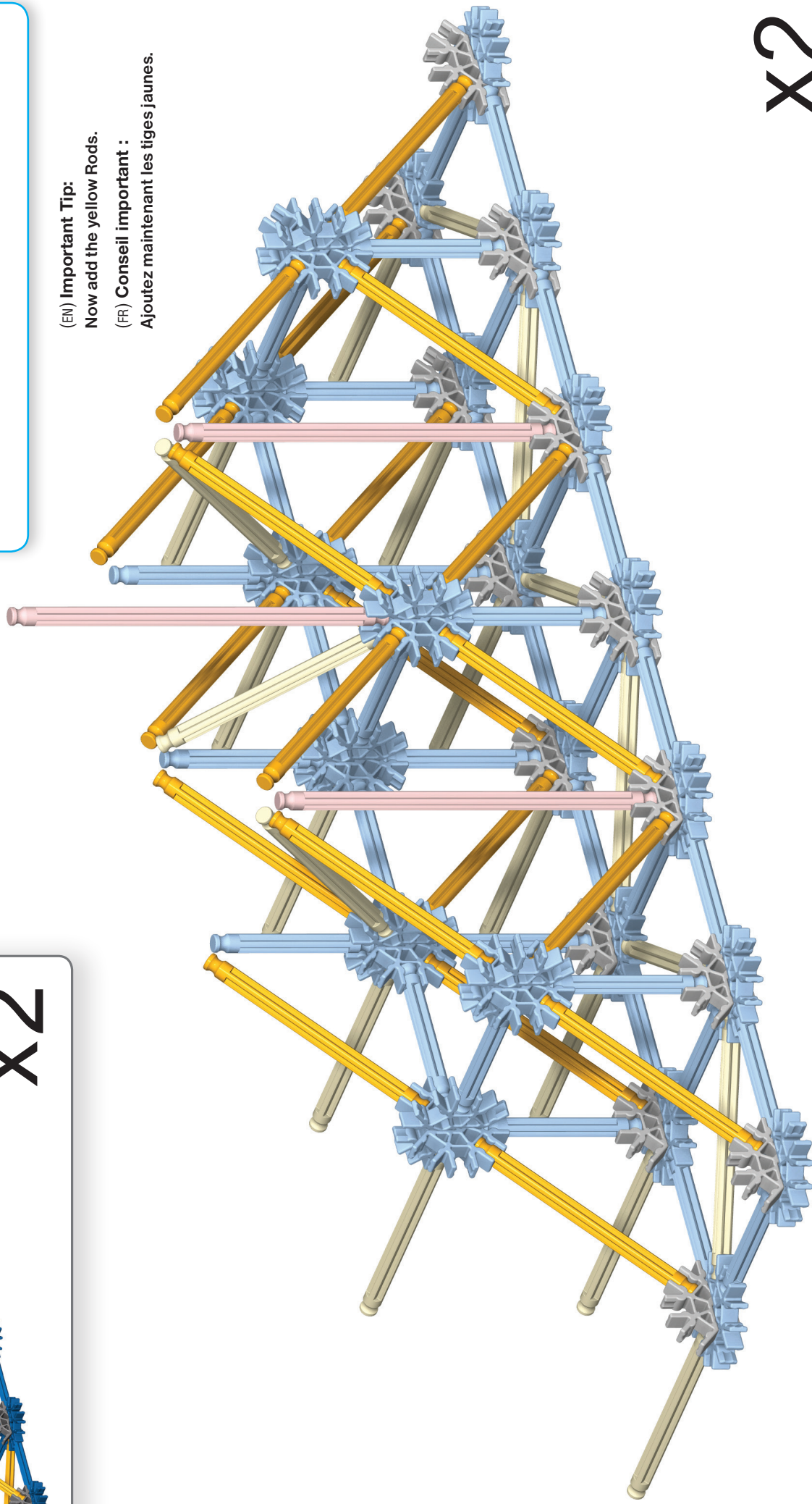

X2

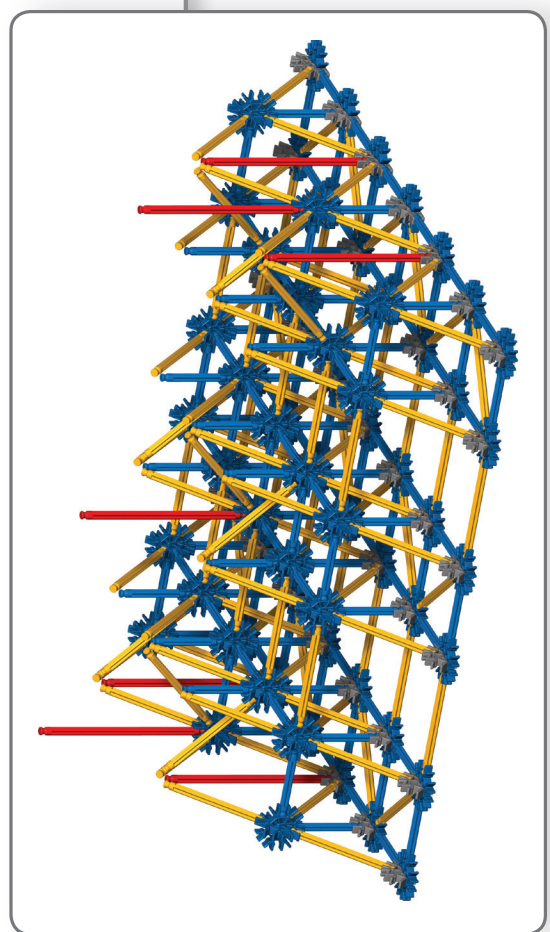
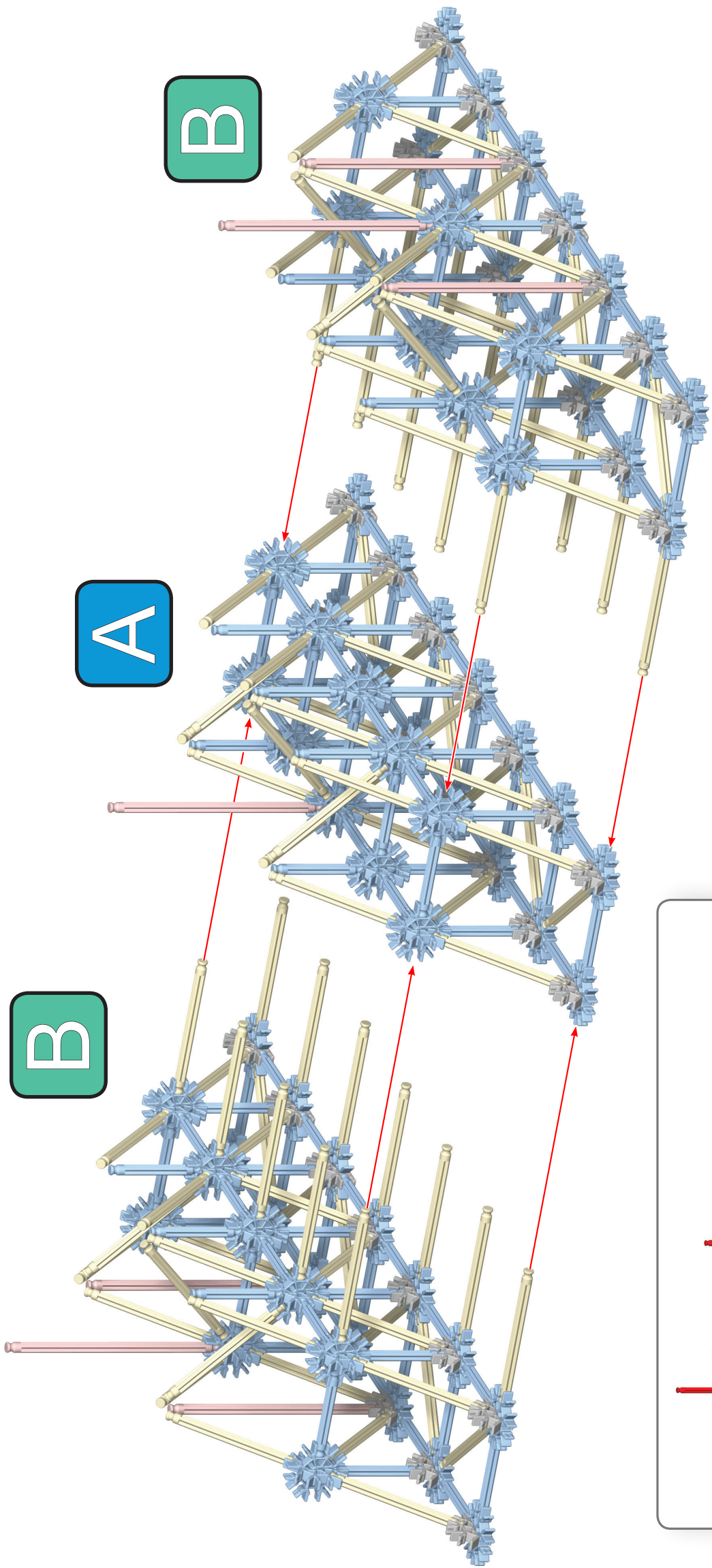



**(EN) Important Tip:**  
First put together all the 2 Connector parts that are listed below before you start to build the section on this page.

**(FR) Conseil important :**  
Assemblez d'abord tous les éléments à 2 connecteurs qui sont indiqués ci-dessous avant de vous mettre à construire la section figurant sur cette page.

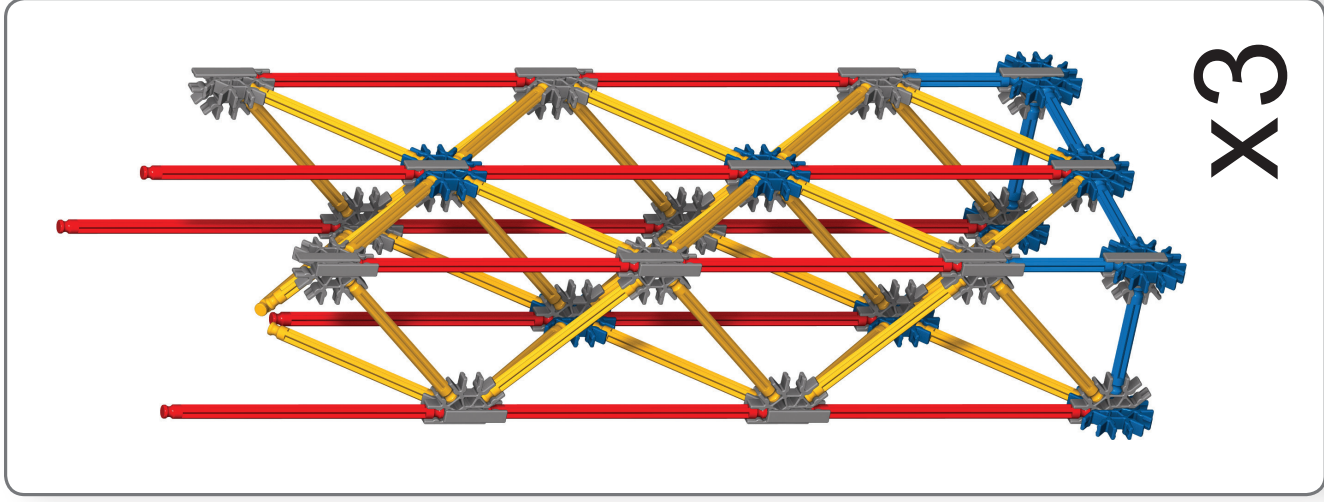
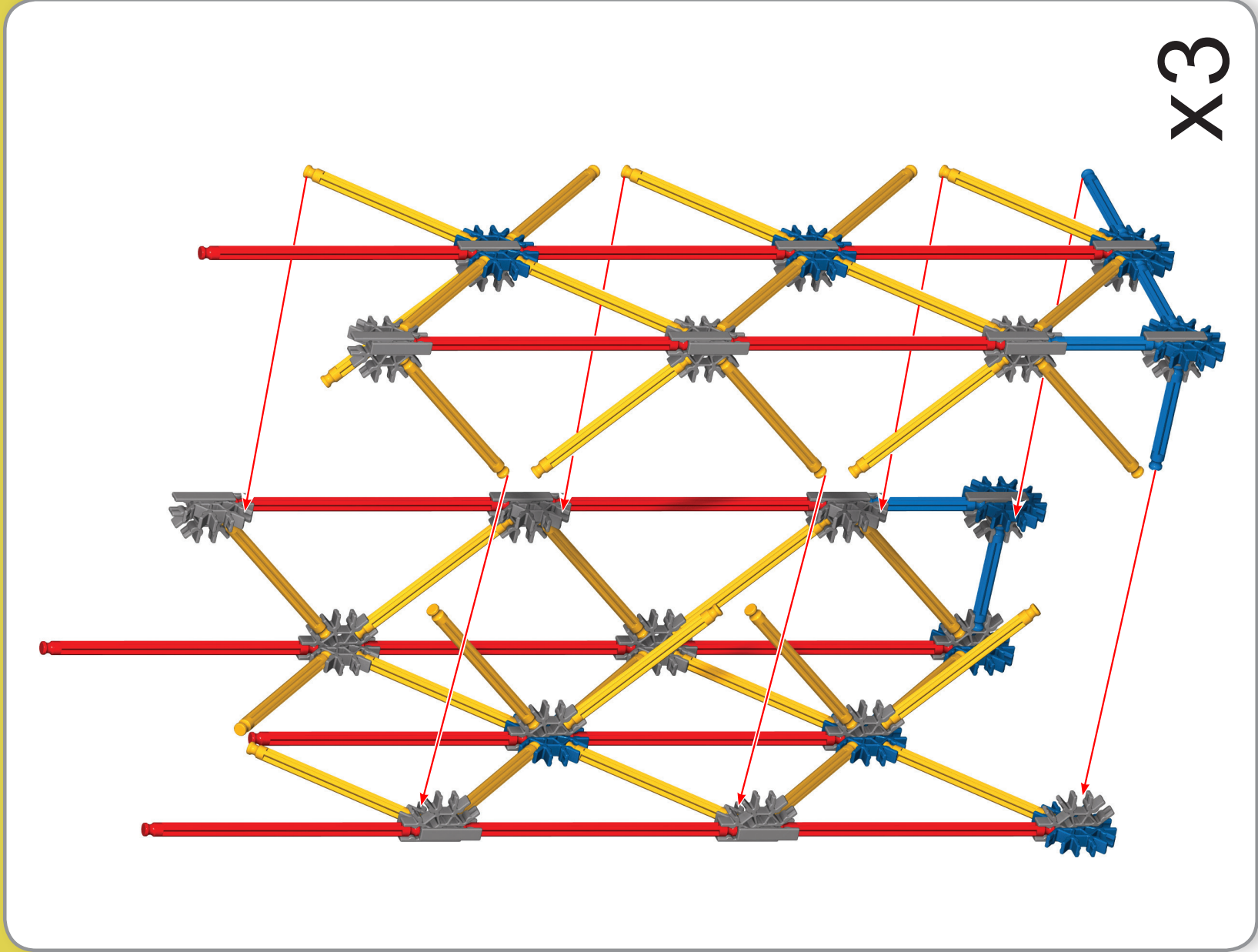
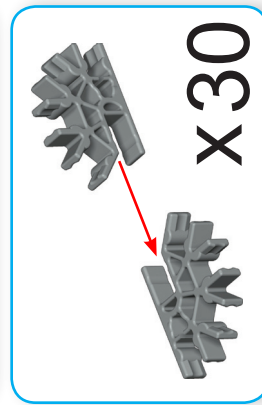
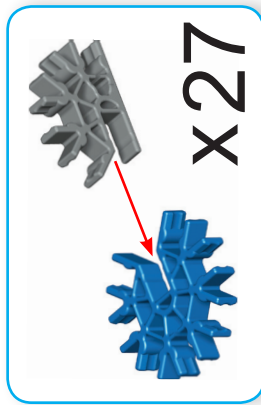



**(EN) Important Tip:**  
First put together all the 2 Connector parts that are listed below before you start to build the section on this page.

**(FR) Conseil important :**  
Assemblez d'abord tous les éléments à 2 connecteurs qui sont indiqués ci-dessous avant de vous mettre à construire la section figurant sur cette page.

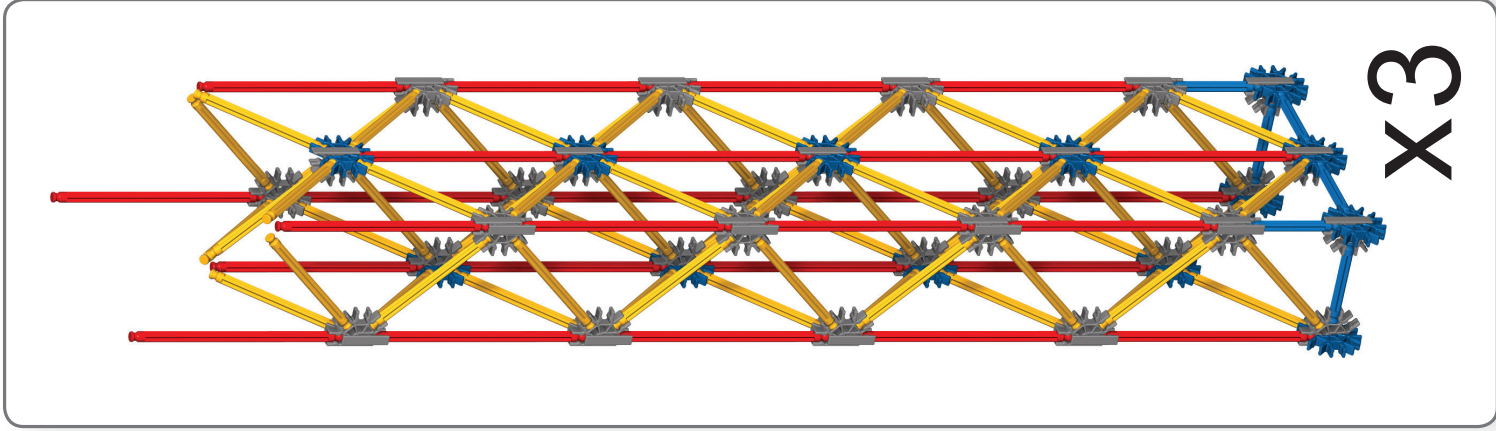
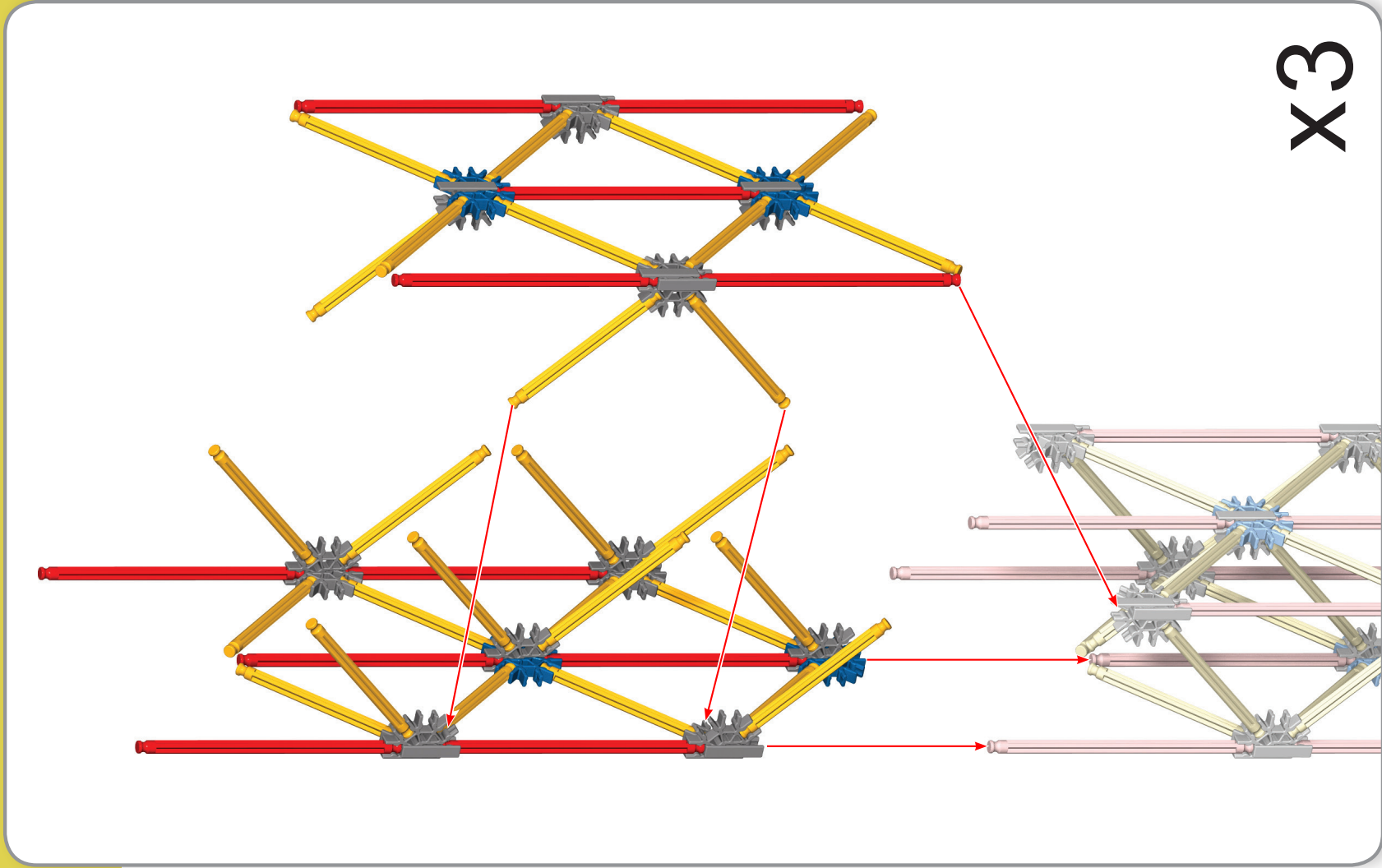
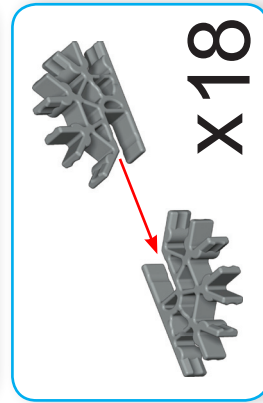
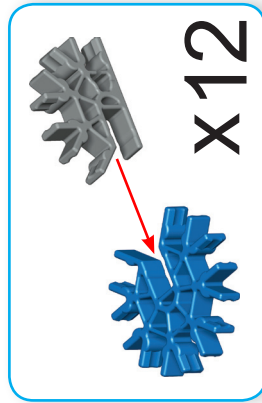

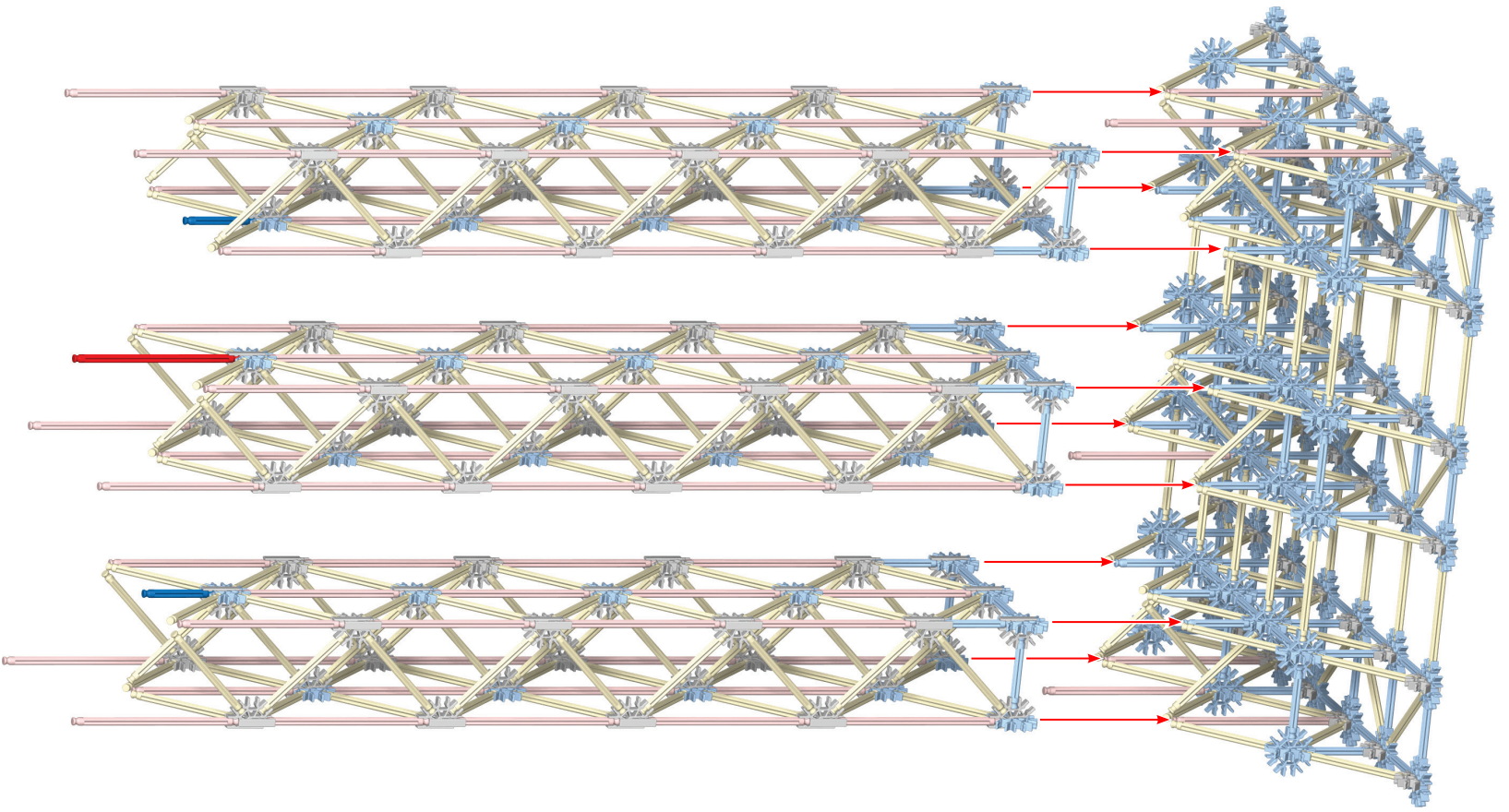
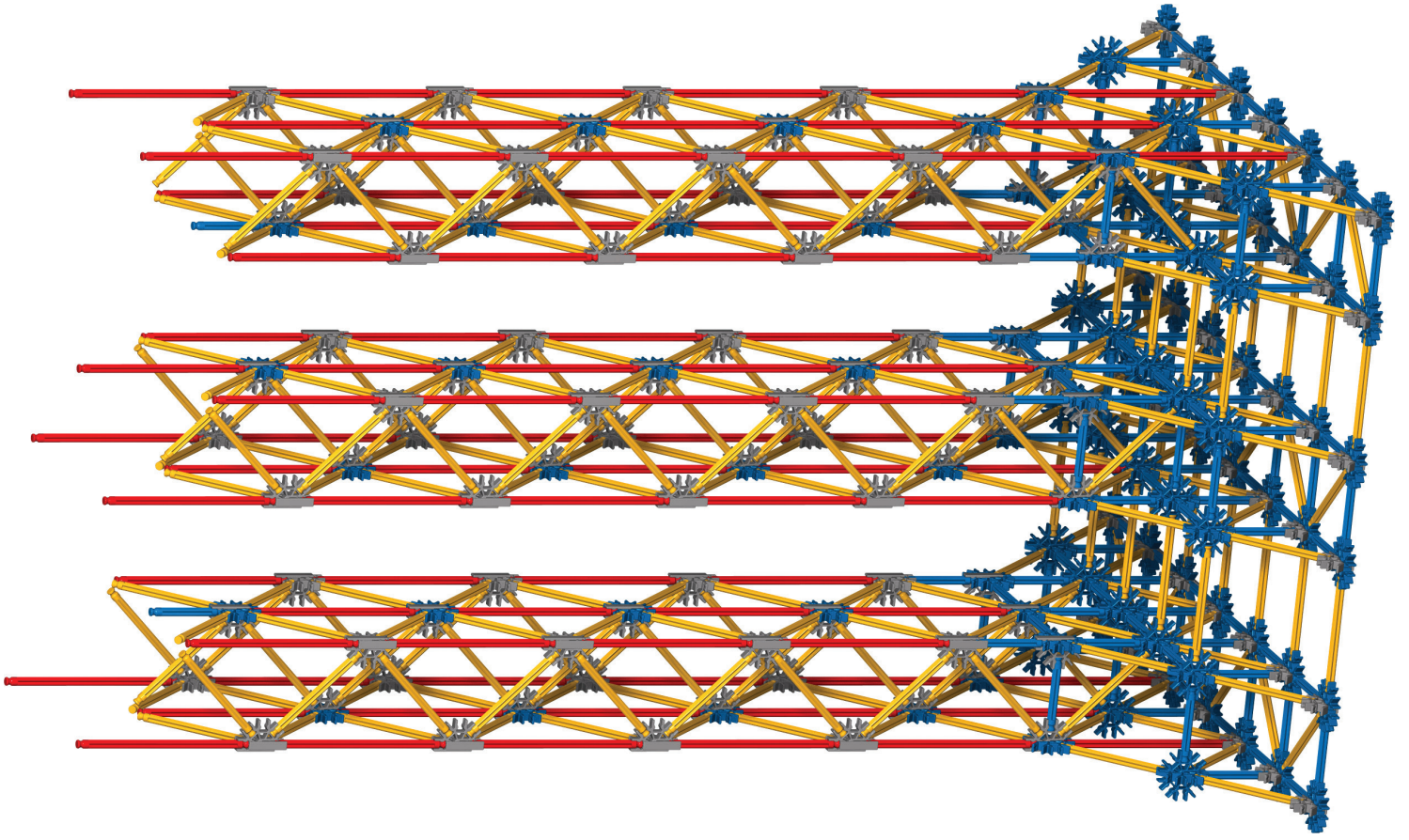

**(EN) Important Tip:**  
First put together all the 2 Connector parts that are listed below before you start to build the section on this page.

**(FR) Conseil important :**  
Assemblez d'abord tous les éléments à 2 connecteurs qui sont indiqués ci-dessous avant de vous mettre à construire la section figurant sur cette page.

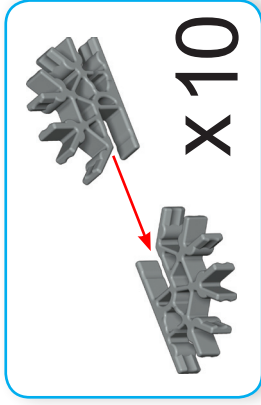
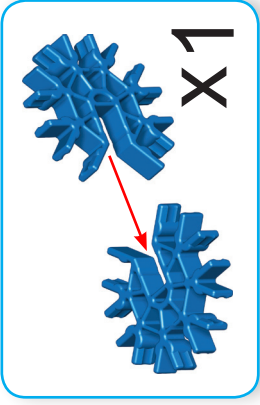
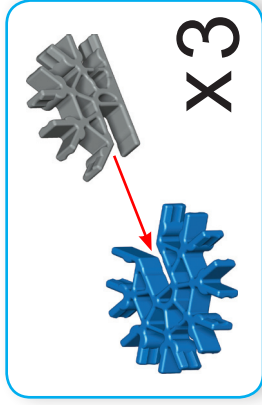

**(EN) Important Tip:**  
Make sure that you use the correct number of blue and silver Spacers.

**(FR) Conseil important :**  
Veillez à utiliser le bon nombre d'espaces bleus et argent.

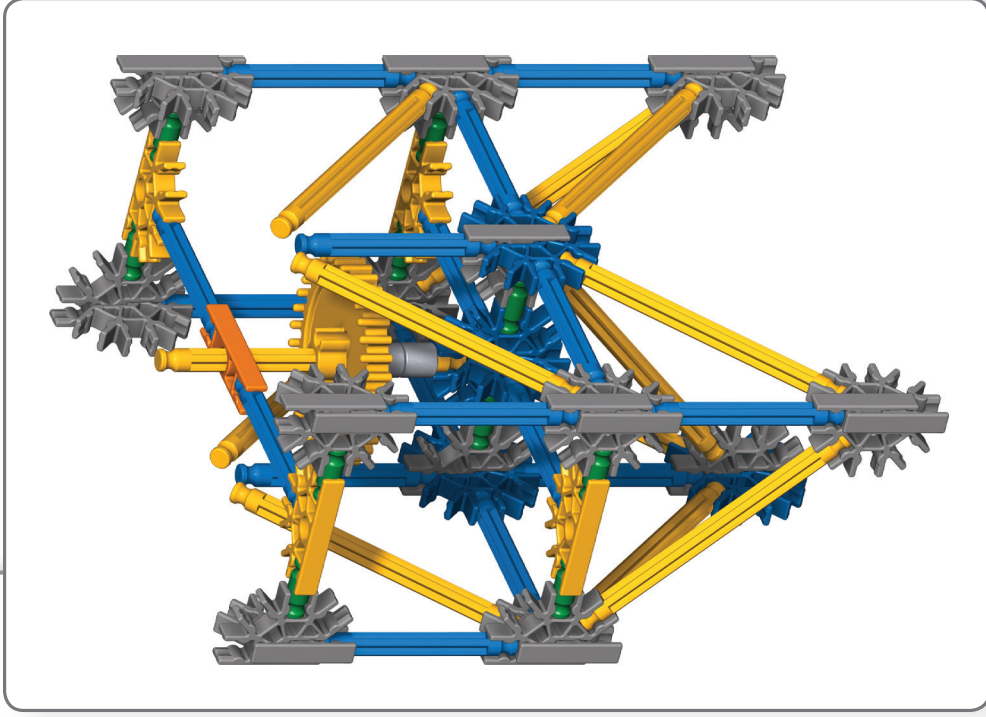
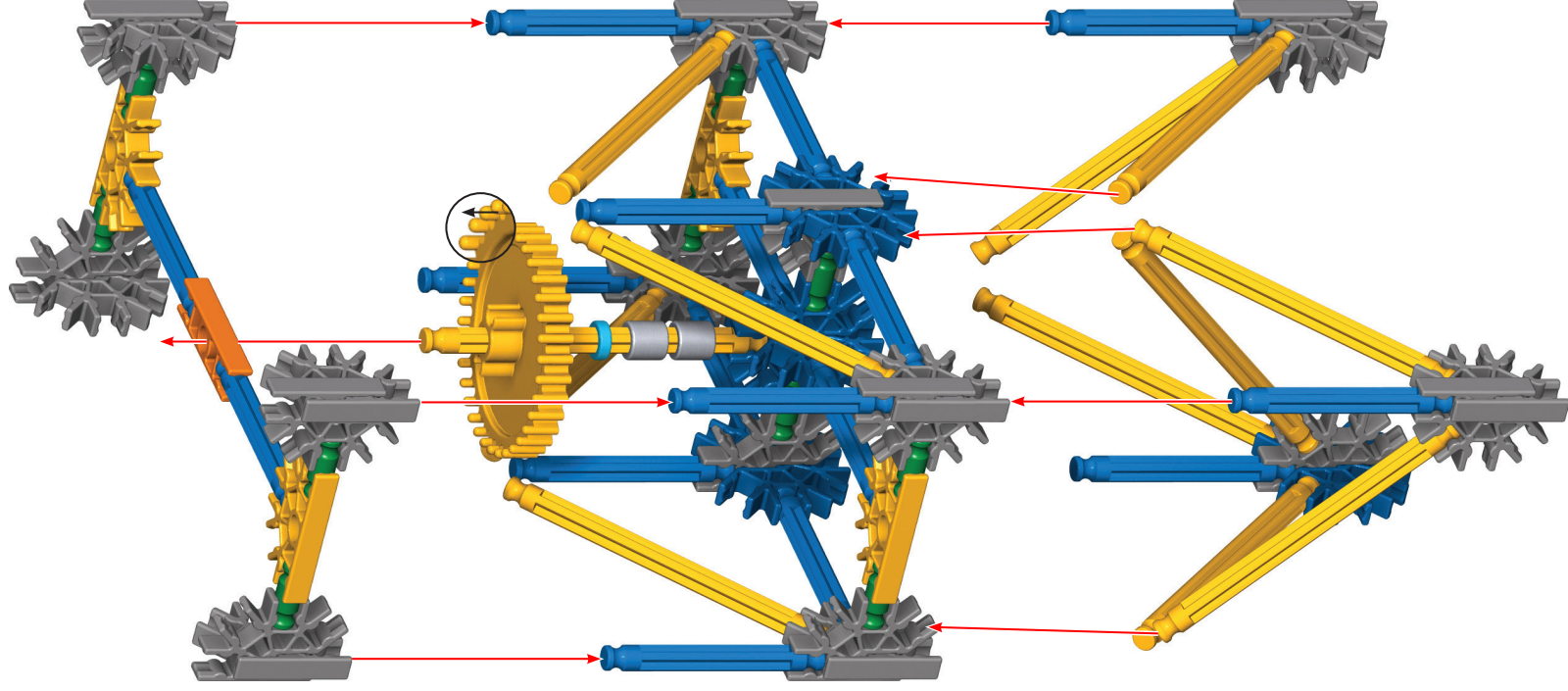
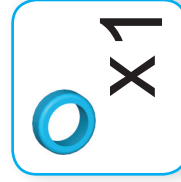

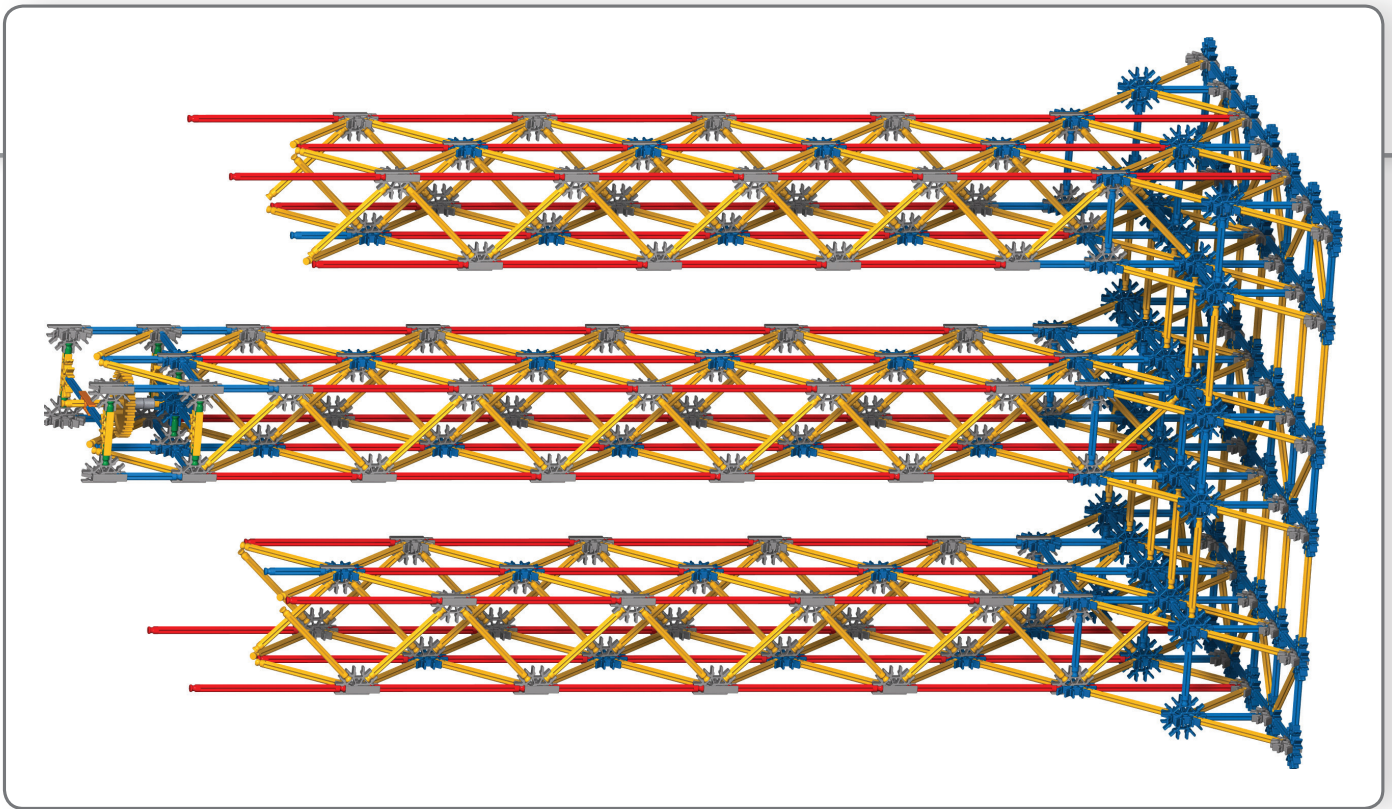
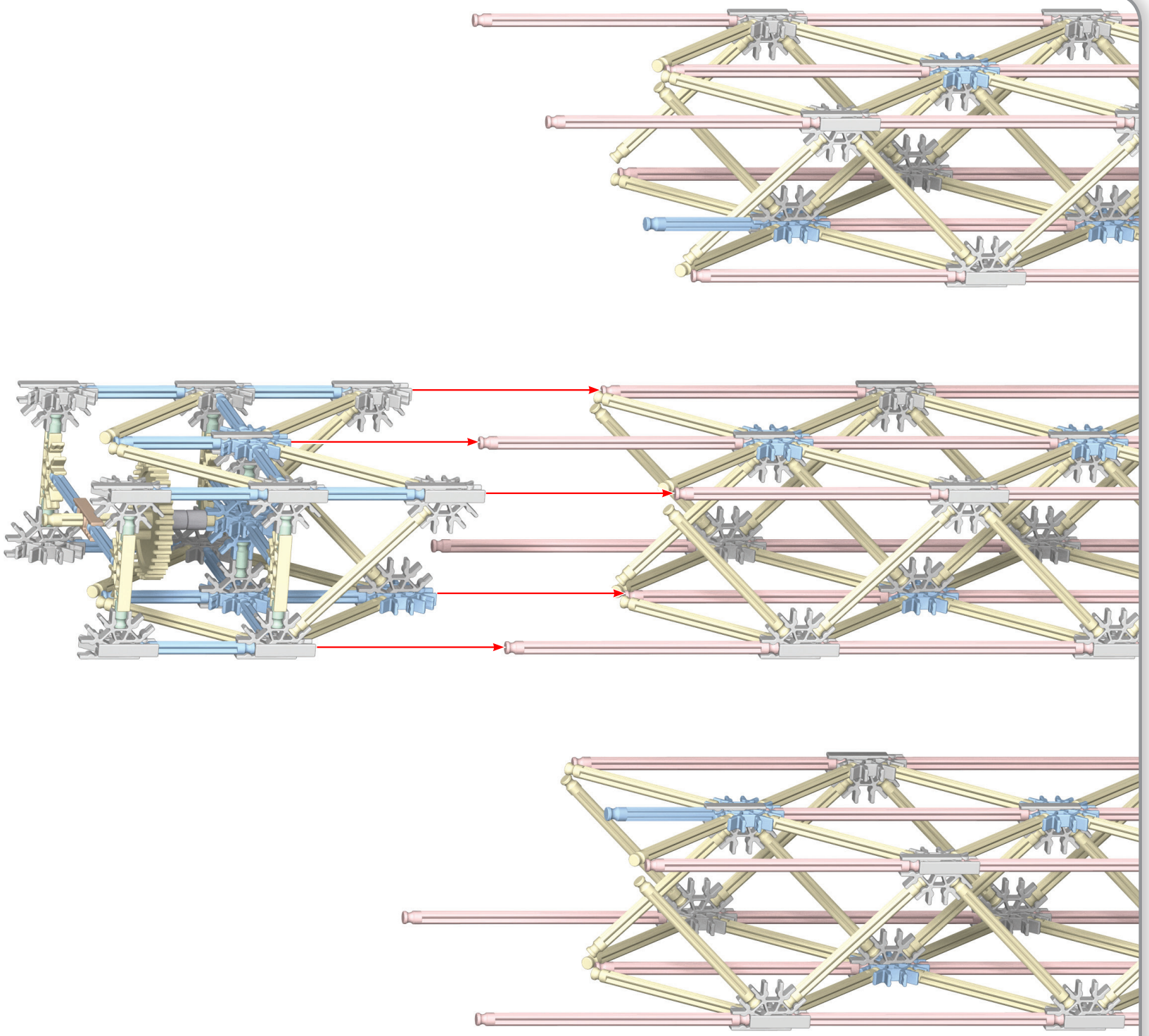

(EN) **Important Tip:**  
Make sure that you use the correct number of blue and silver Spacers.  
(FR) **Conseil important :**  
Veillez à utiliser le bon nombre d'espaces bleus et argent.

 X2

(EN) **Important Tip:**  
Make sure that the tan locks are pushed into the notches on the gears and the holes in the gray wheels.  
(FR) **Conseil important :**  
Veillez à ce que les verrous de couleur marron soient bien enfoncés dans les encoches qui se trouvent sur l'engrenage et dans les trous des roues grises.

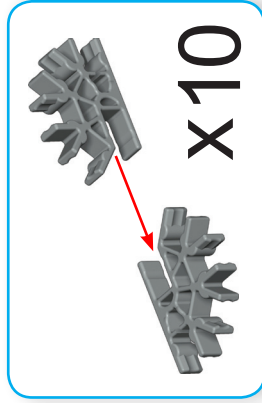
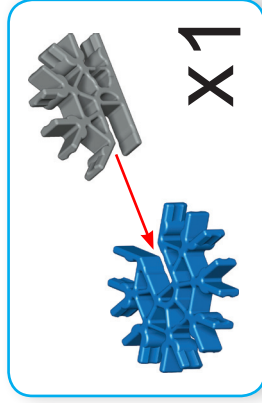
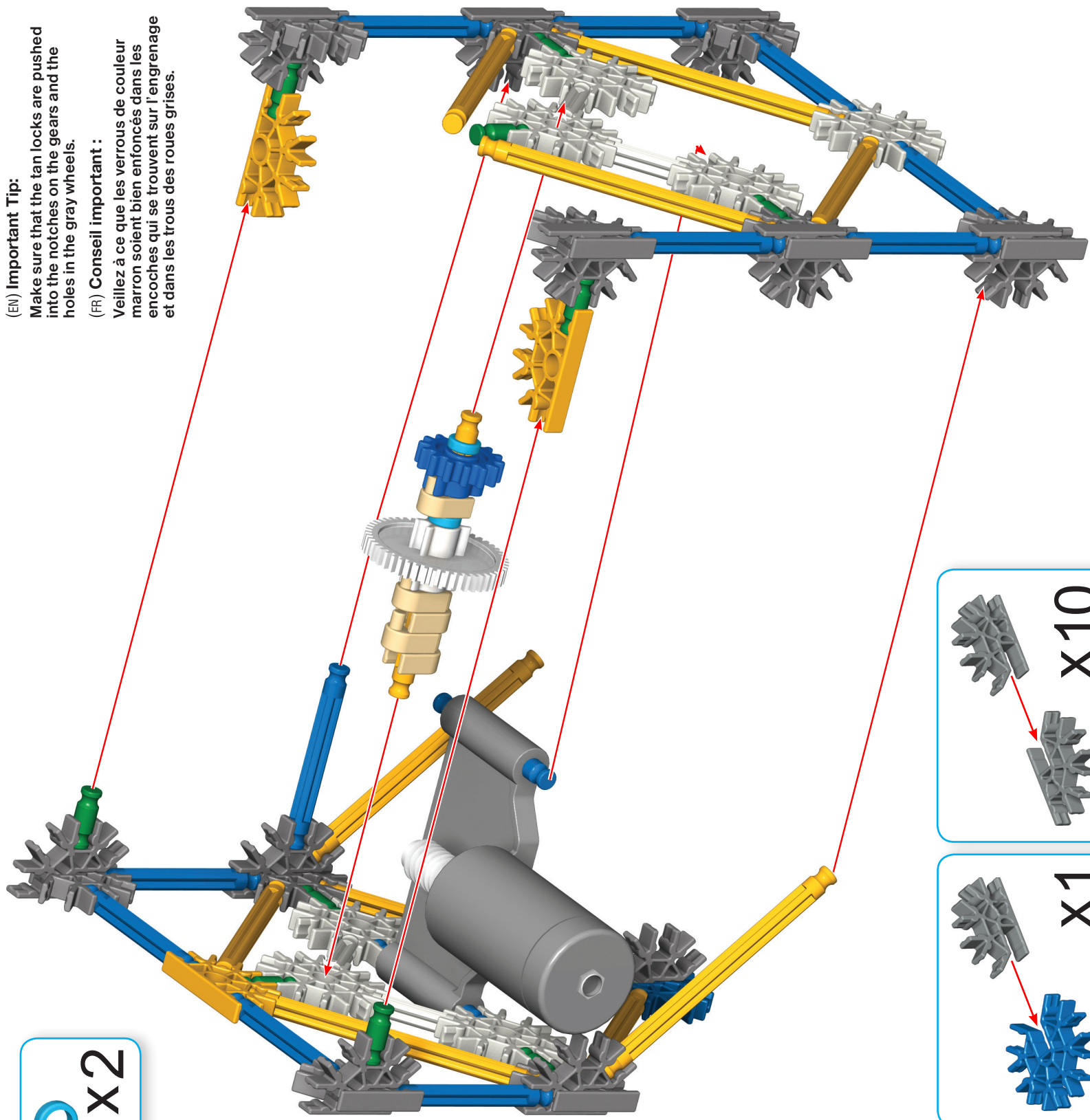
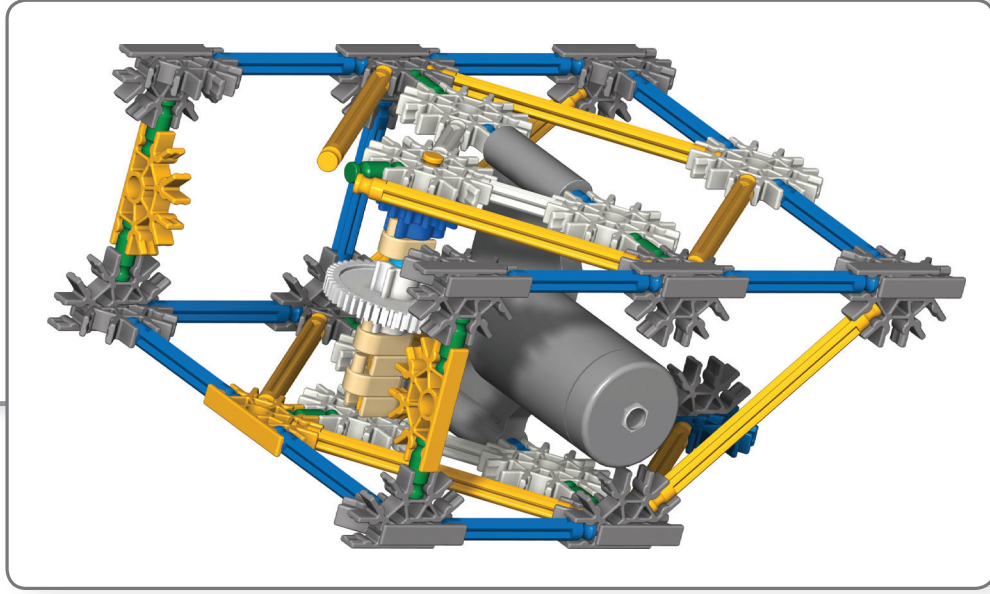

(EN) **Important Tip:**  
First put together all the 2 Connector parts that are listed here before you start to build the section on this page.  
(FR) **Conseil important :**  
Assemblez d'abord tous les éléments à 2 connecteurs qui sont indiqués ici avant de vous mettre à construire la section figurant sur cette page.

**(EN) Important Tip:**  
 Make sure that the tan locks are pushed into the notches on the gears and the holes in the gray wheels.  
**(FR) Conseil important :**  
 Veillez à ce que les verrous de couleur marron soient bien enfoncés dans les encoches qui se trouvent sur l'engrenage et dans les trous des roues grises.

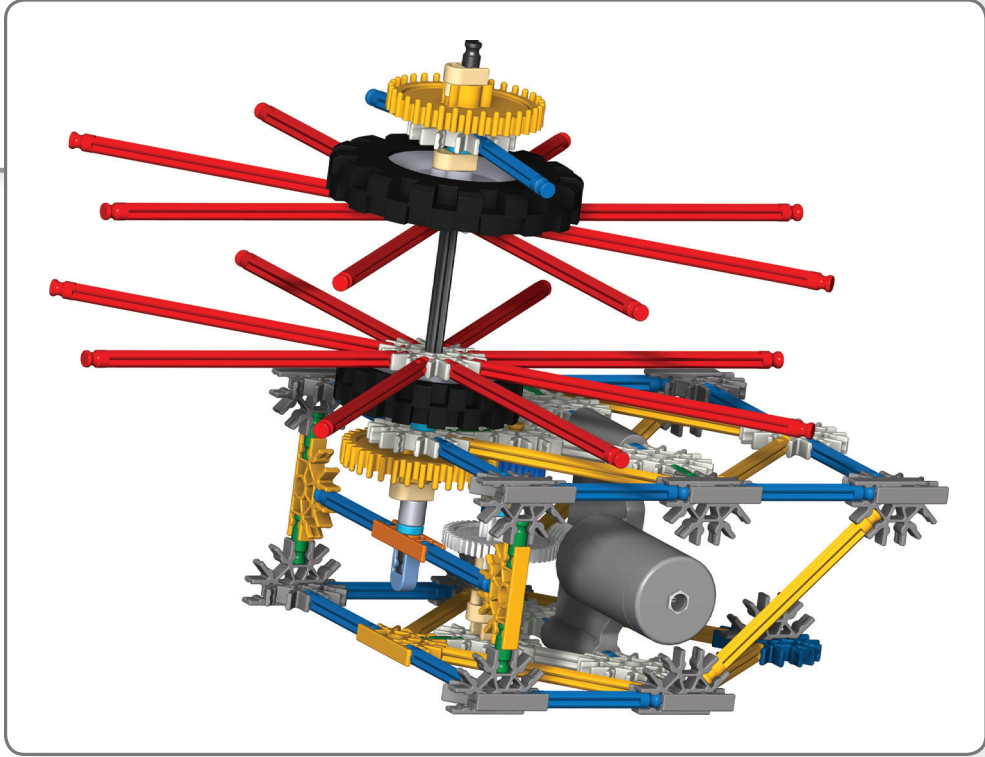
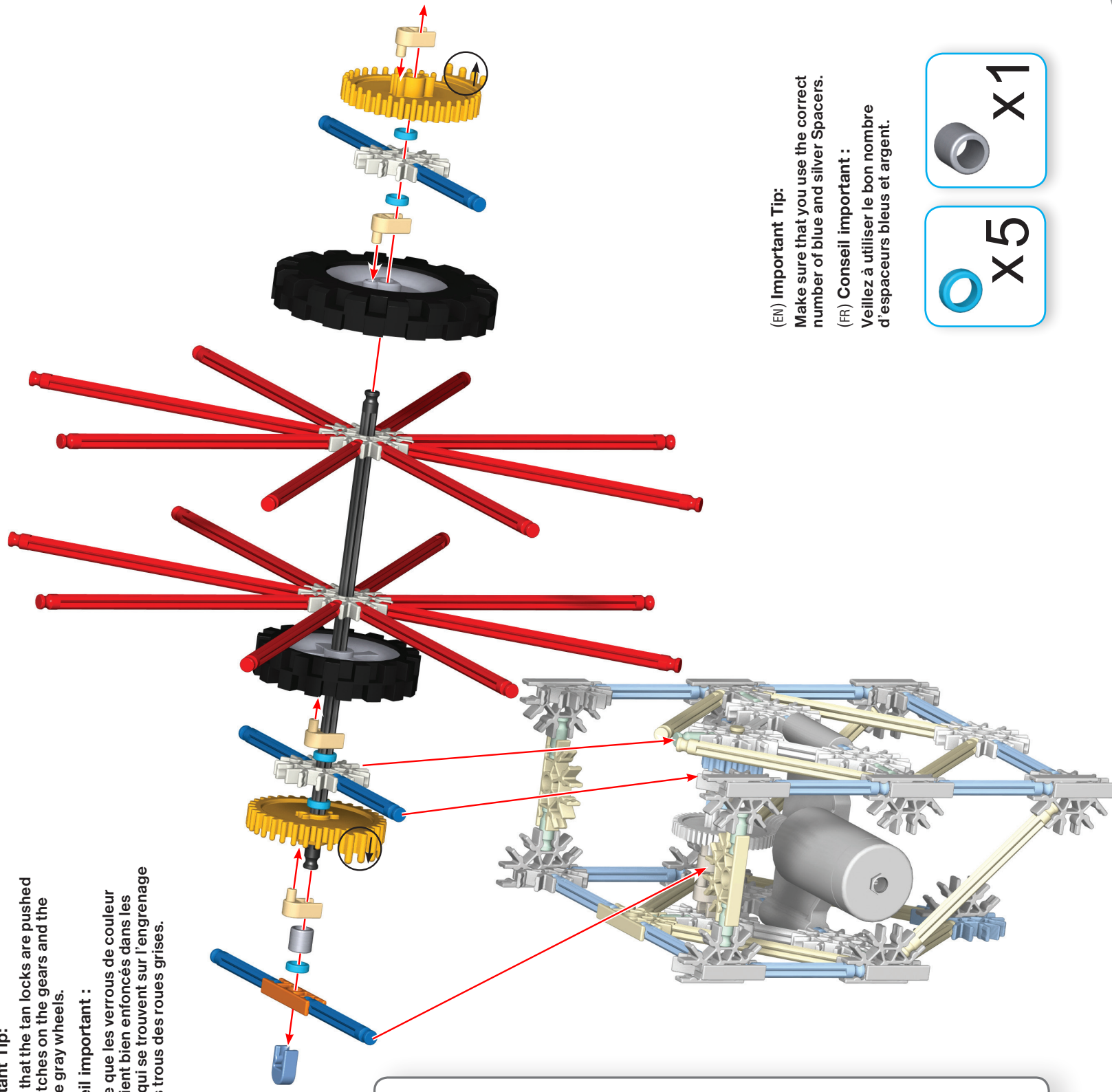

**(EN) Important Tip:**  
 Make sure that you use the correct number of blue and silver Spacers.  
**(FR) Conseil important :**  
 Veillez à utiliser le bon nombre d'espaces bleus et argent.

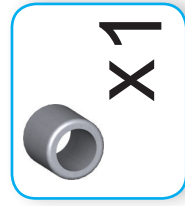
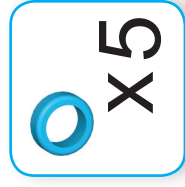

(EN) Important Tip:  
Make sure the teeth of the 2 yellow  
gears mesh together.

(FR) Conseil important :  
Veillez à ce que les dents des 2  
engrenages jaunes s'engrènent bien  
les uns dans les autres.

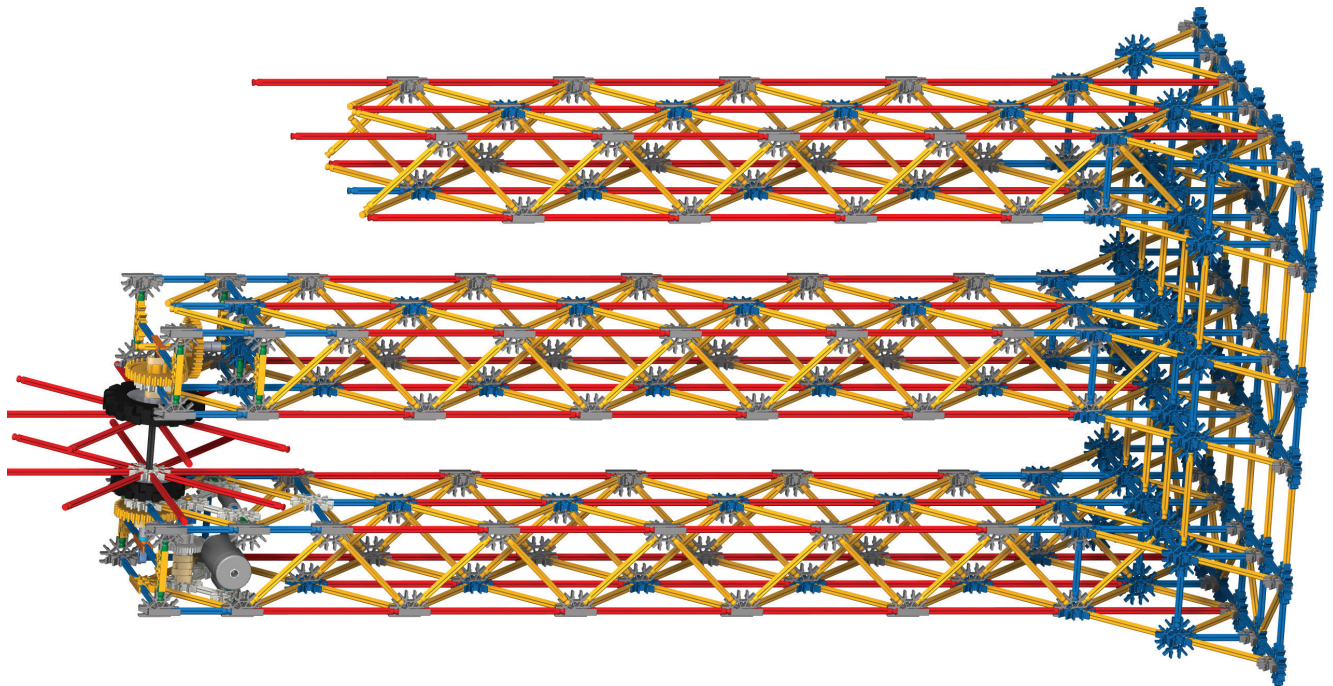
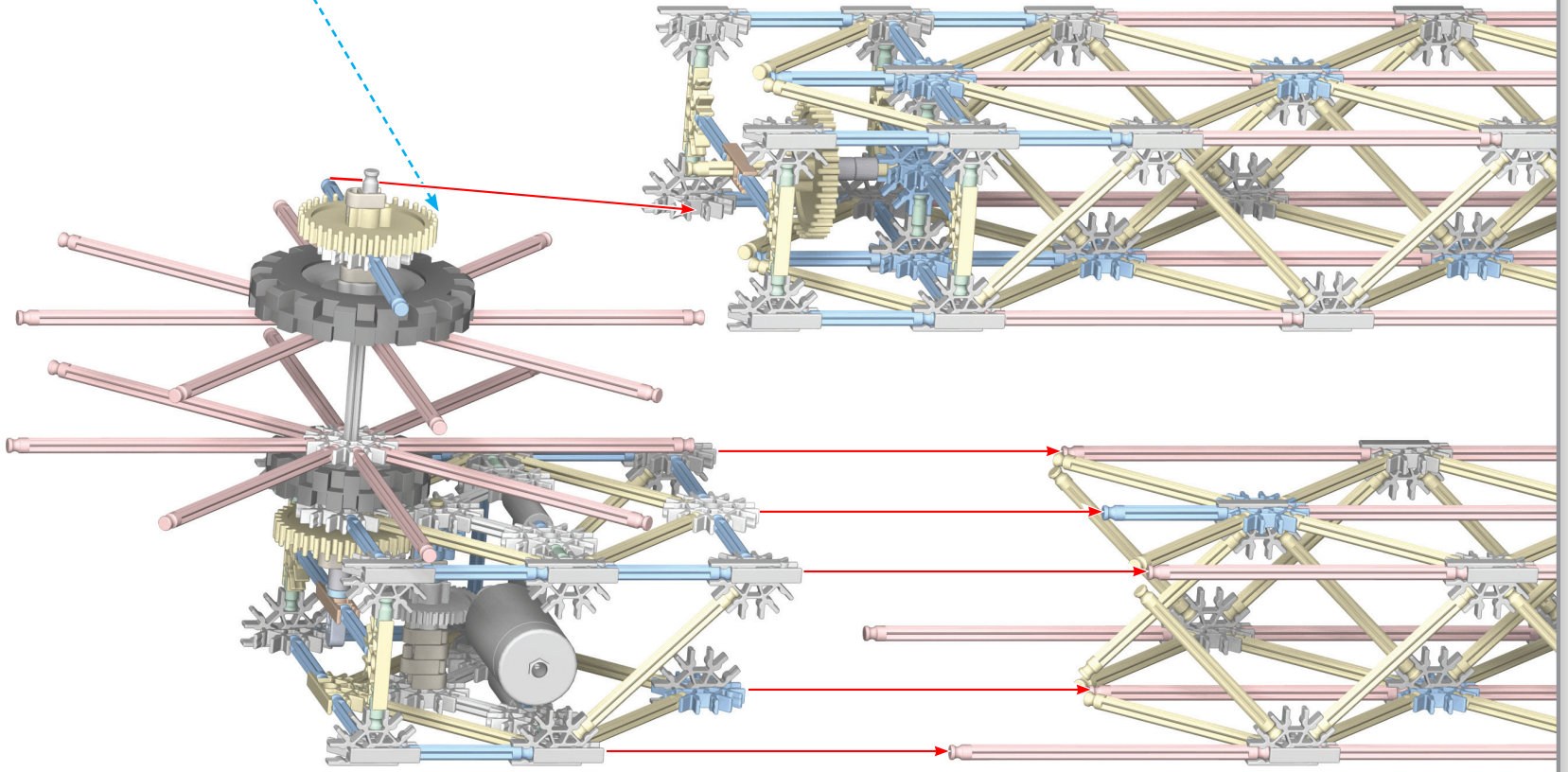
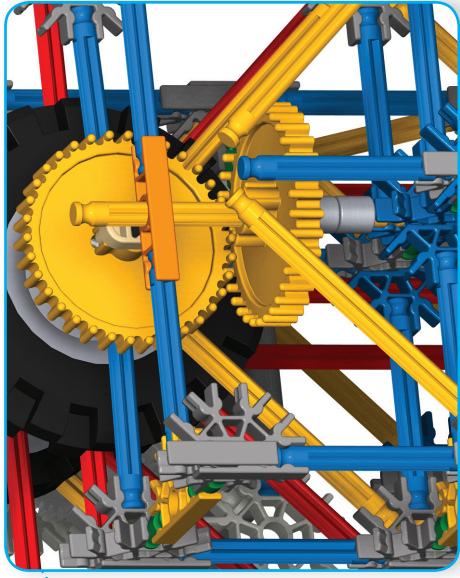

**(EN) Important Tip:**  
 First put together all the 2 Connector parts that are listed here before you start to build the section on this page.

**(FR) Conseil important :**  
 Assemblez d'abord tous les éléments à 2 connecteurs qui sont indiqués ici avant de vous mettre à construire la section figurant sur cette page.

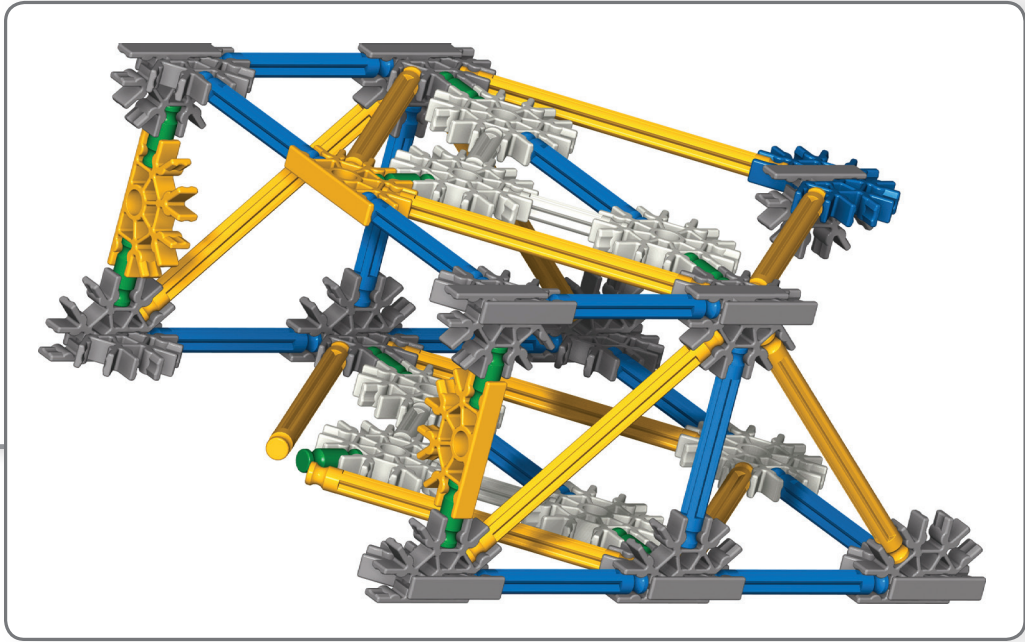
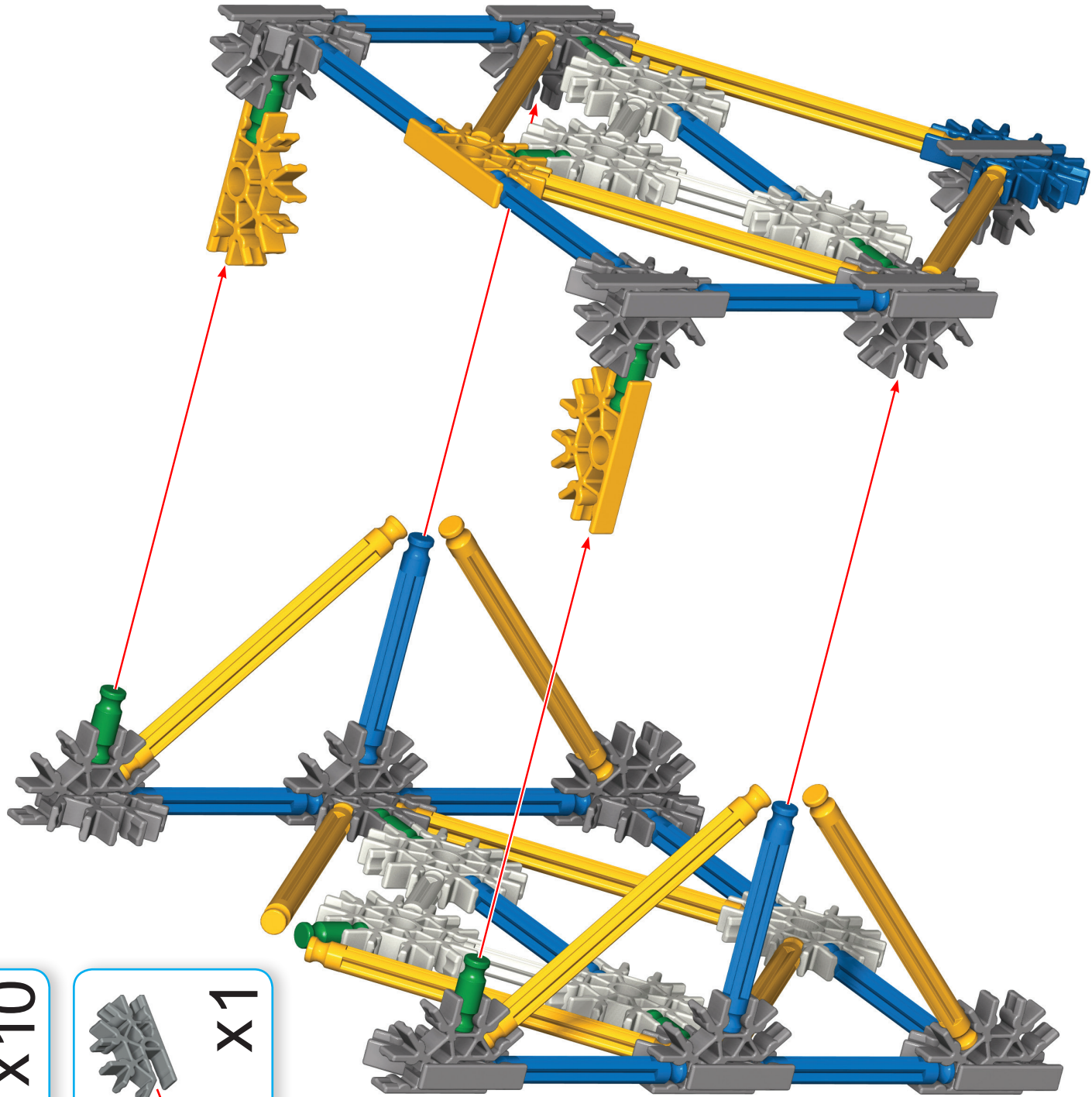
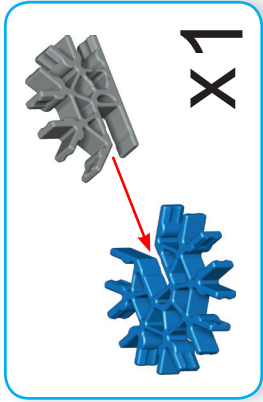
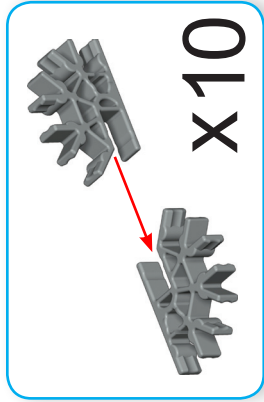

**(EN) Important Tip:**

Make sure that the tan locks are pushed into the notches on the yellow gears and the holes in the gray wheels.

**(FR) Conseil important :**

Veillez à ce que les verrous de couleur marron soient bien enfoncés dans les encoches qui se trouvent sur l'engrenage jaune et dans les trous des roues grises.

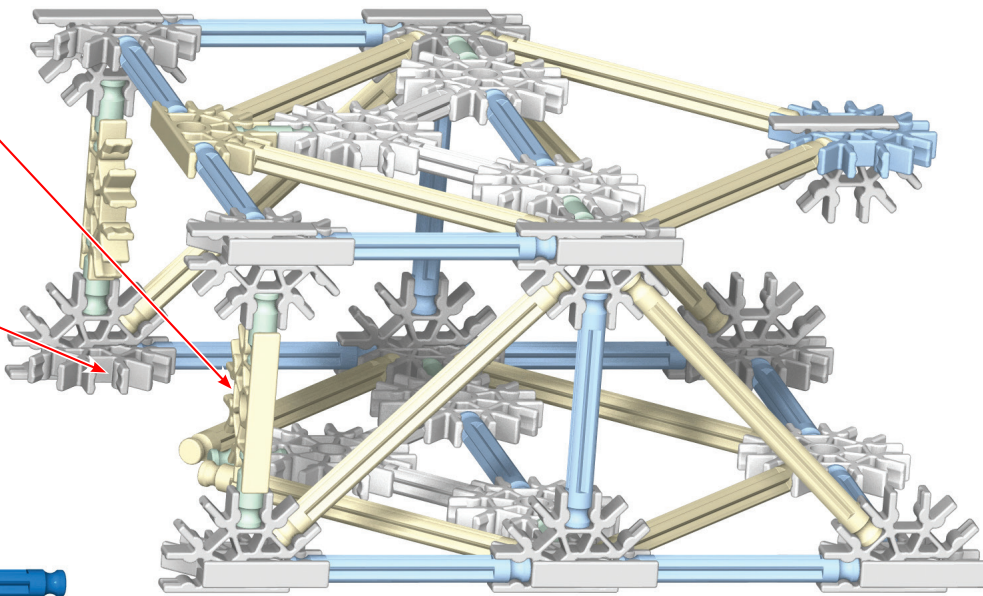
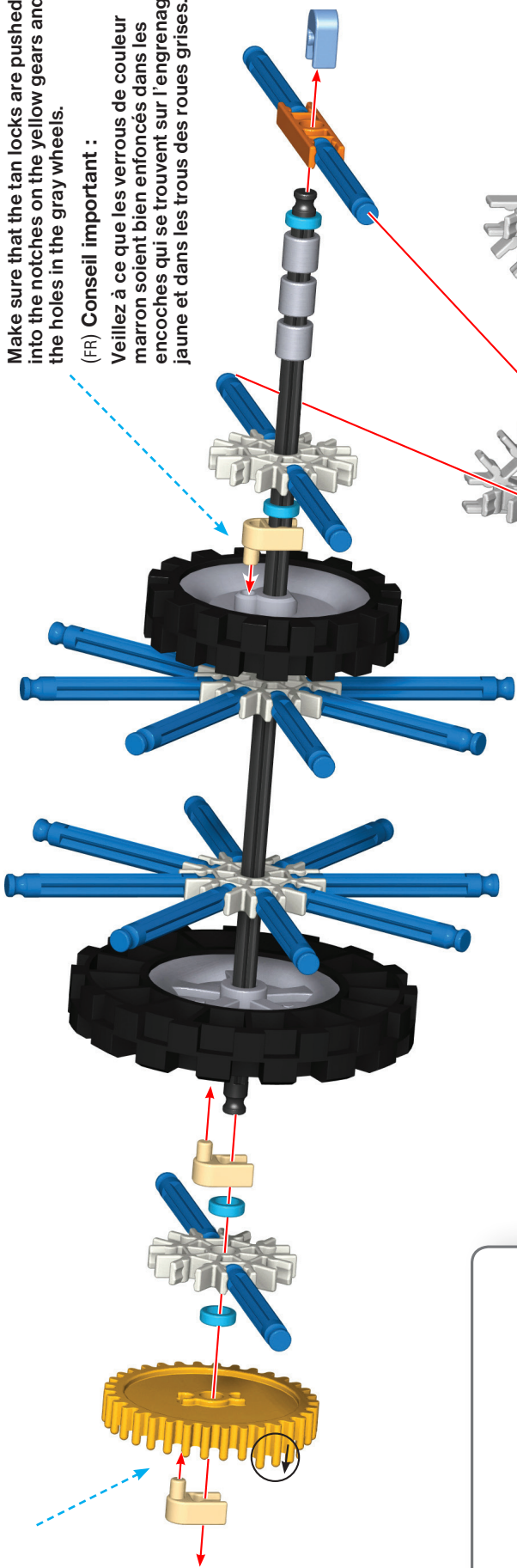

**(EN) Important Tip:**

Make sure that you use the correct number of blue and silver Spacers.

**(FR) Conseil important :**

Veillez à utiliser le bon nombre d'espaces bleus et argent.

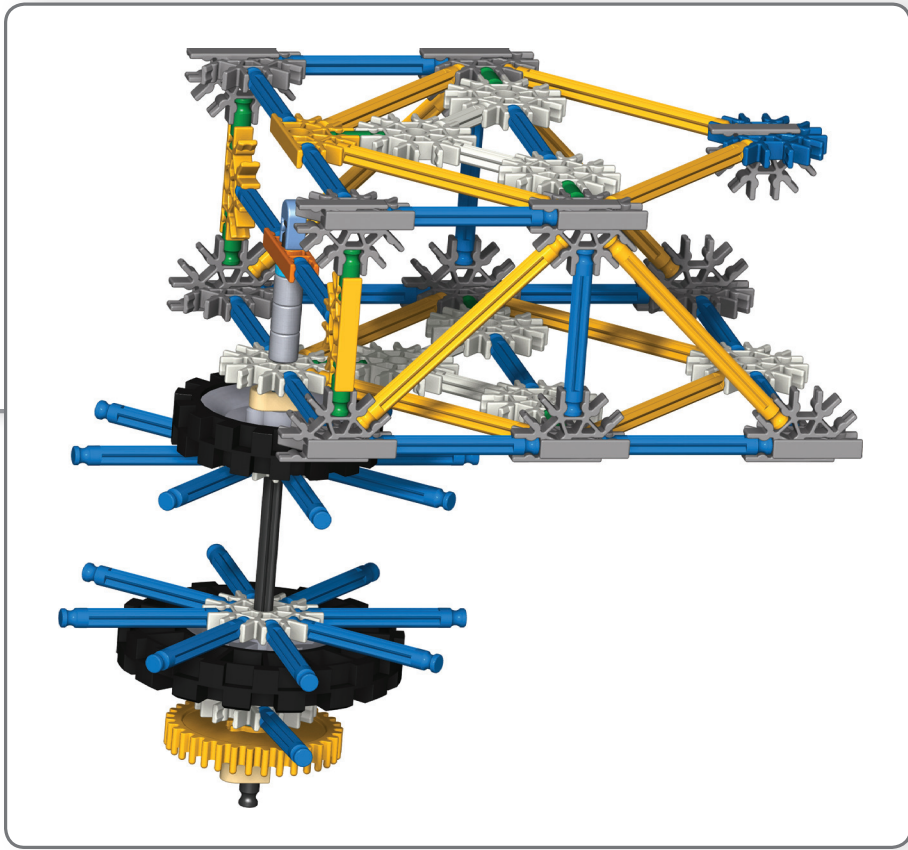
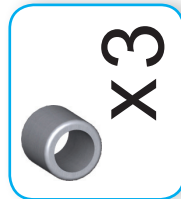
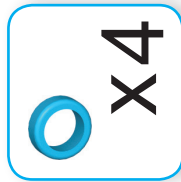

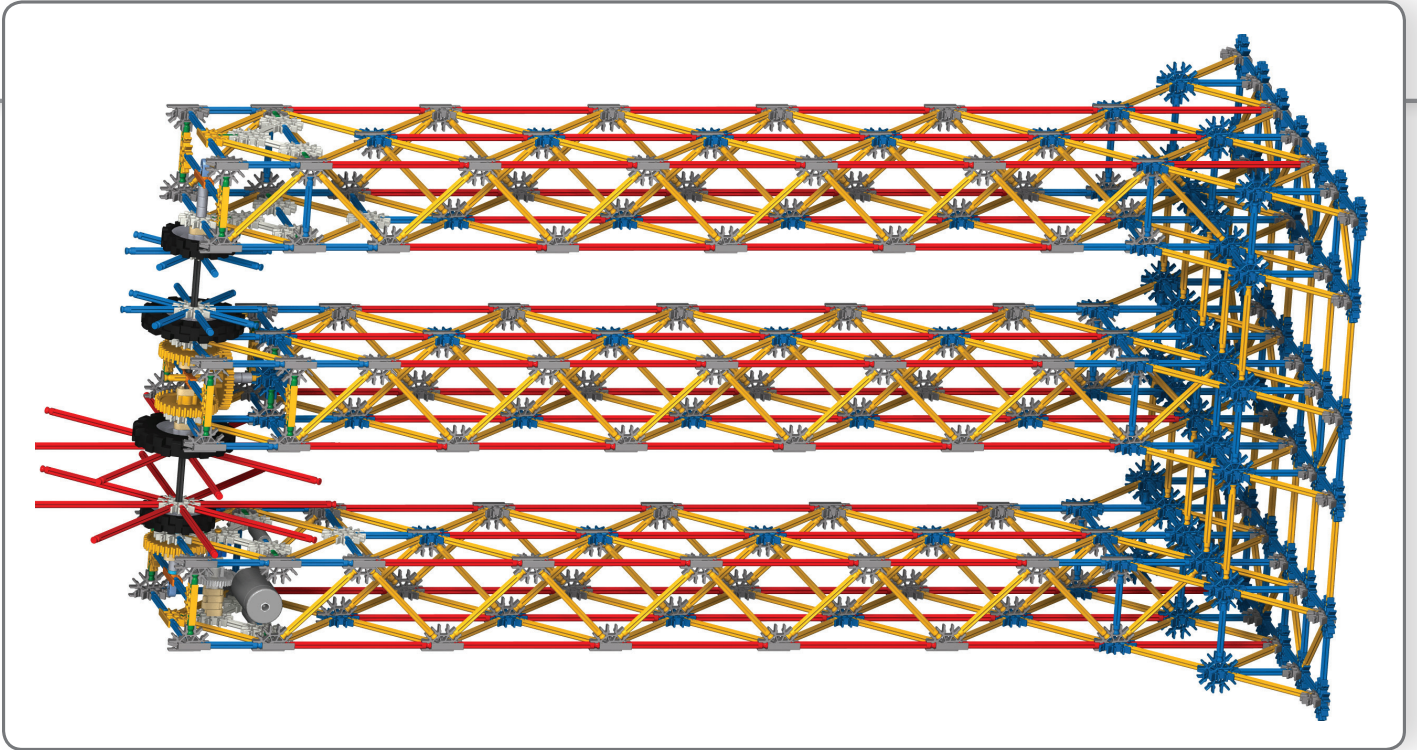
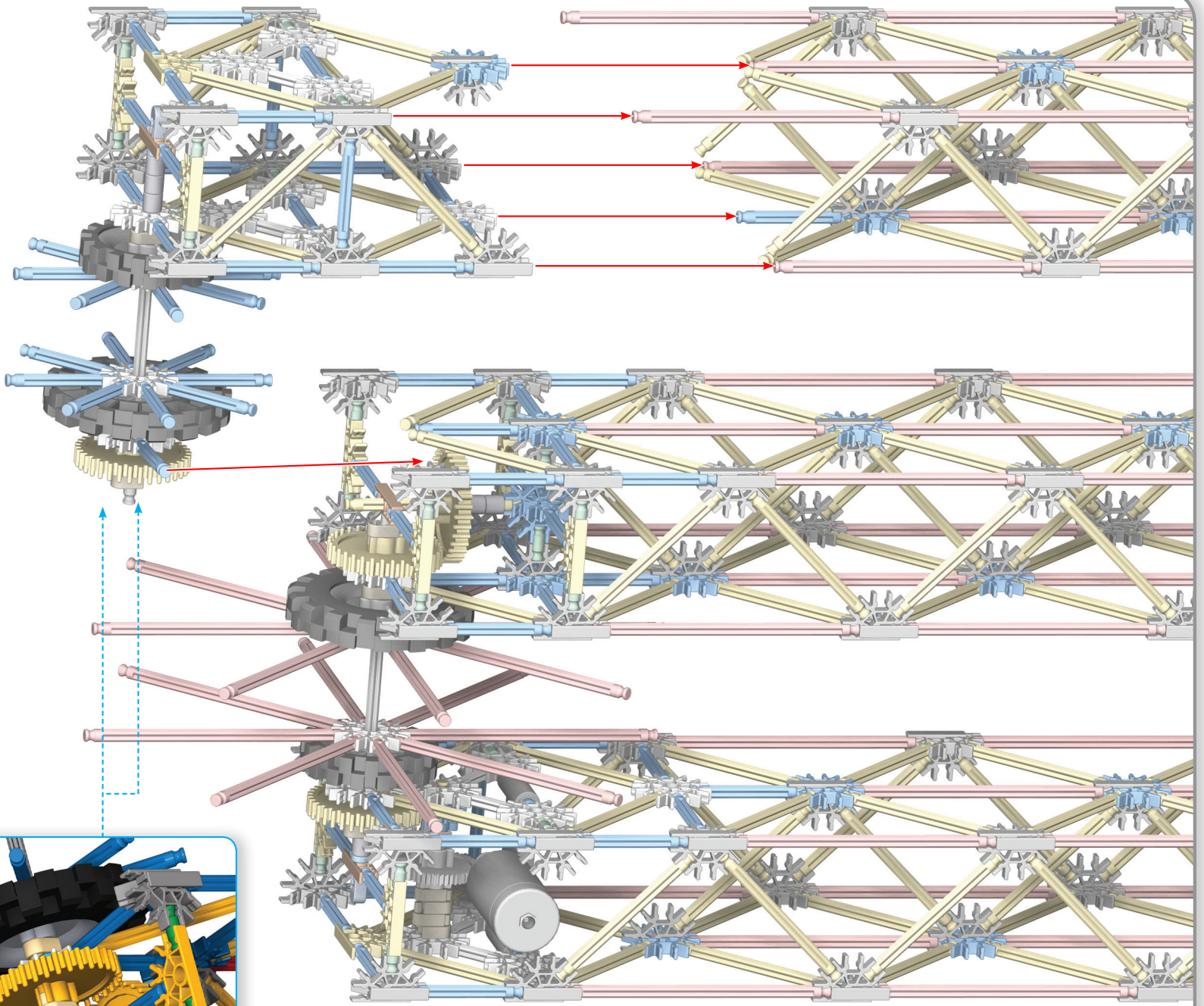
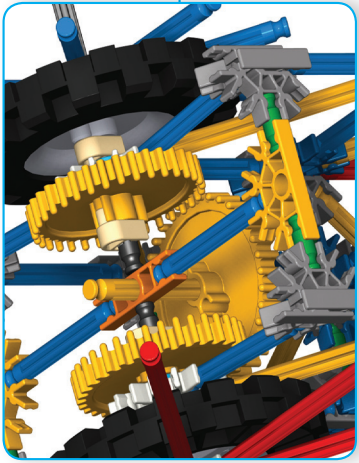

**(EN) Important Tip:**  
 First put together all the 2 Connector parts that are listed below before you start to build the section on this page.

**(FR) Conseil important :**  
 Assemblez d'abord tous les éléments à 2 connecteurs qui sont indiqués ci-dessous avant de vous mettre à construire la section figurant sur cette page.

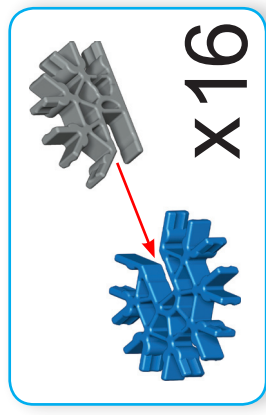

x8

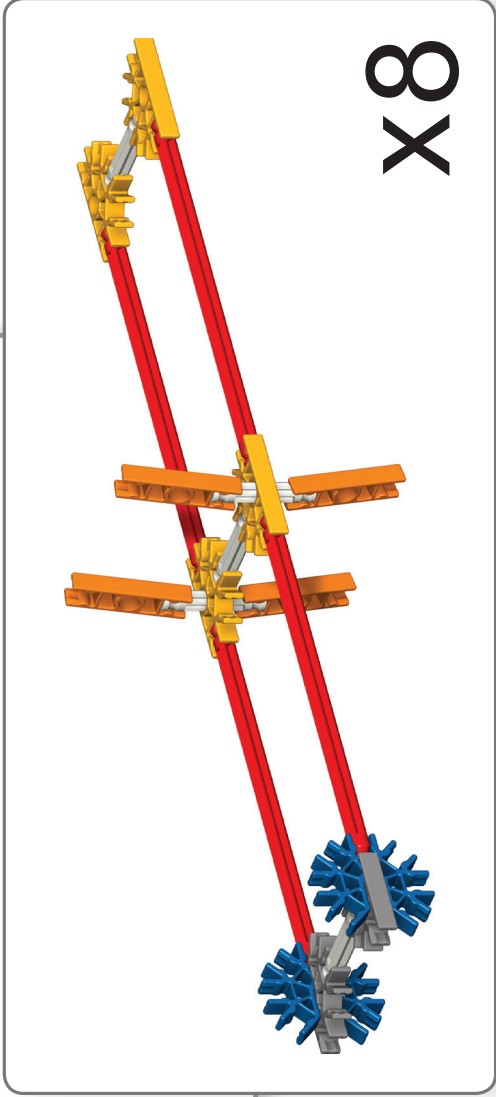
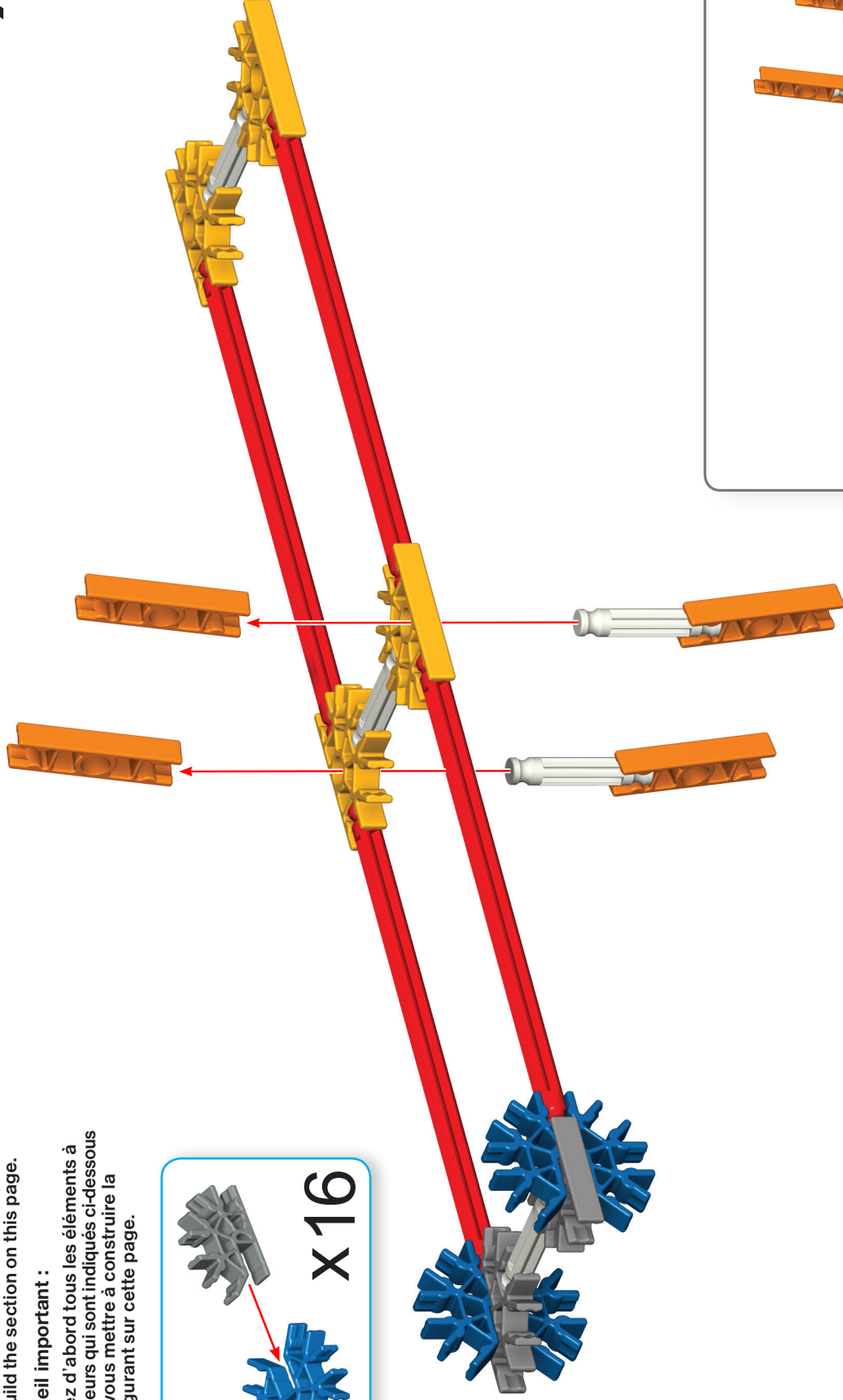

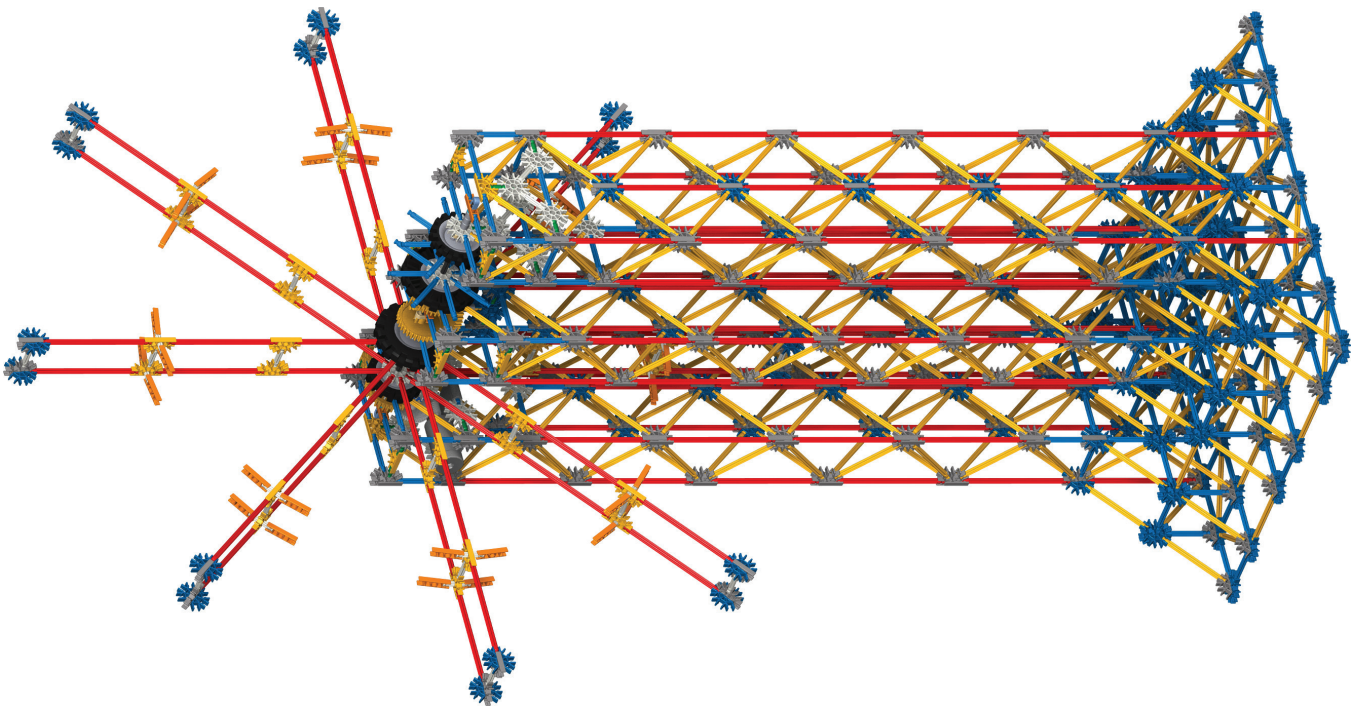
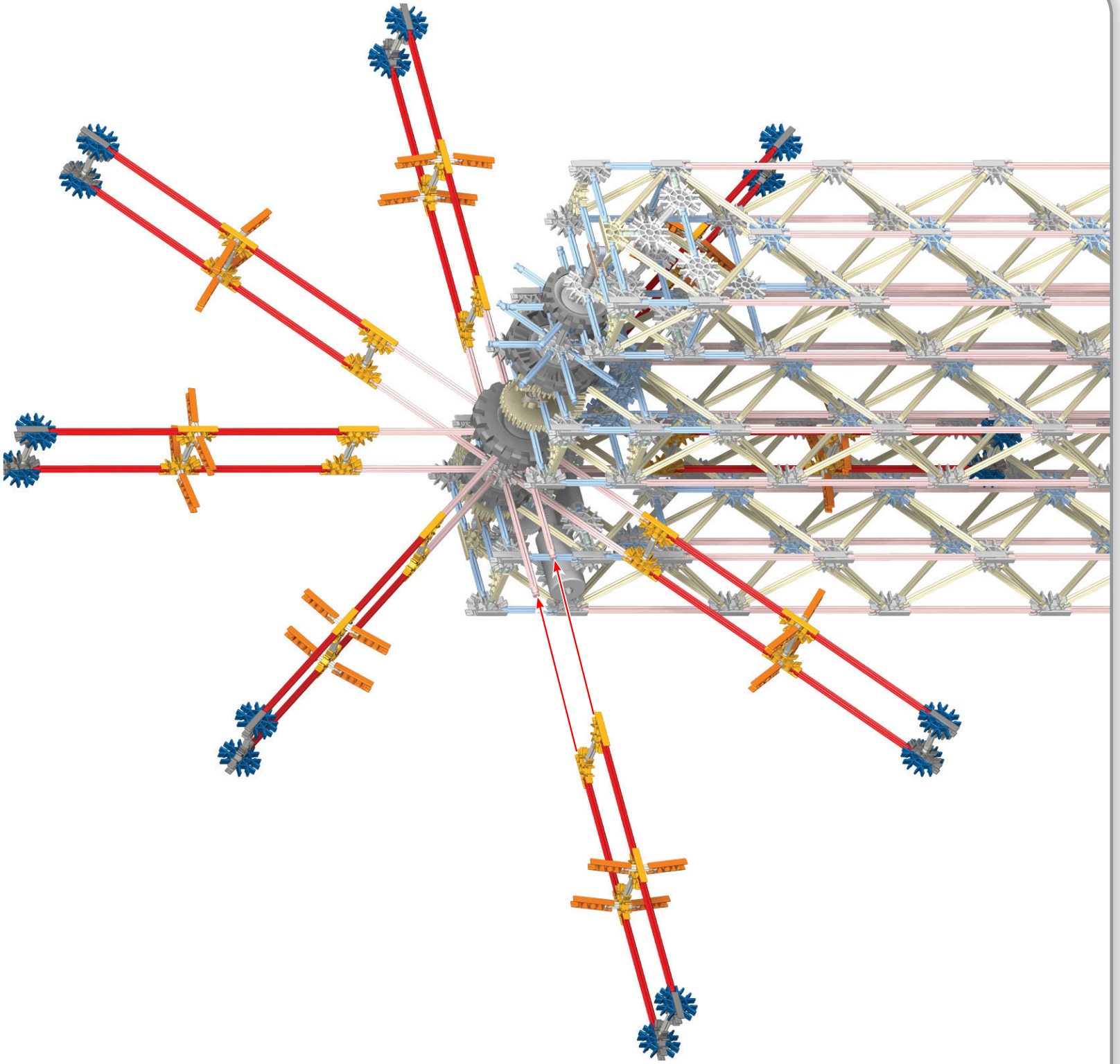

H

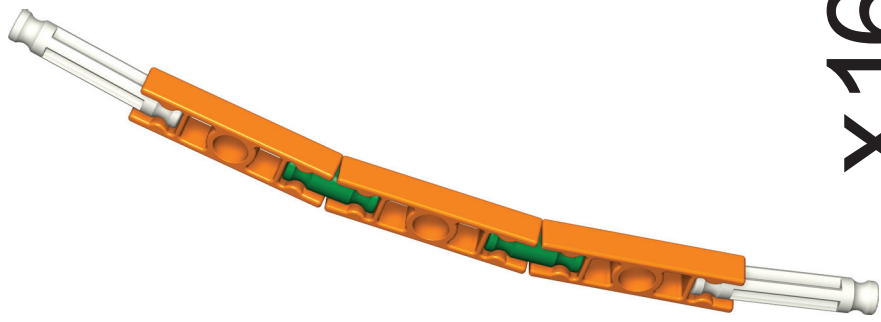

x16

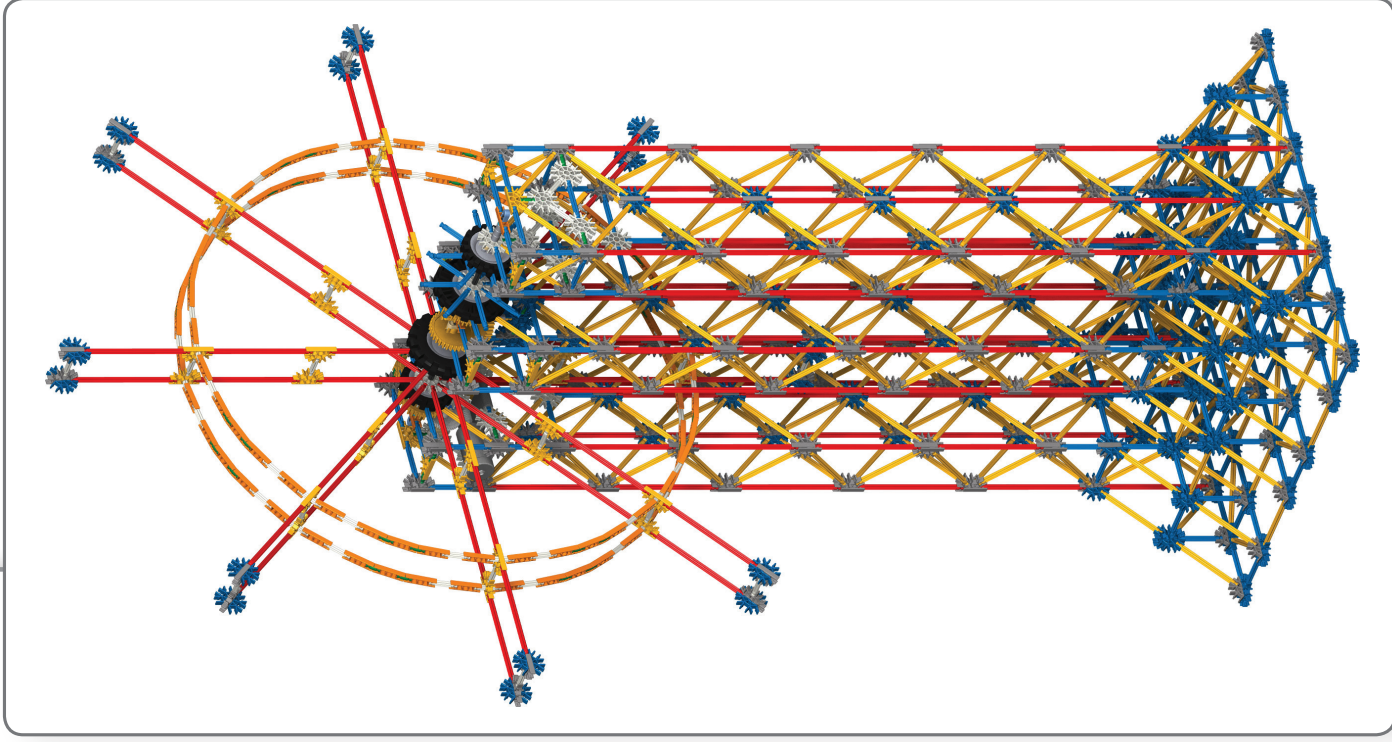
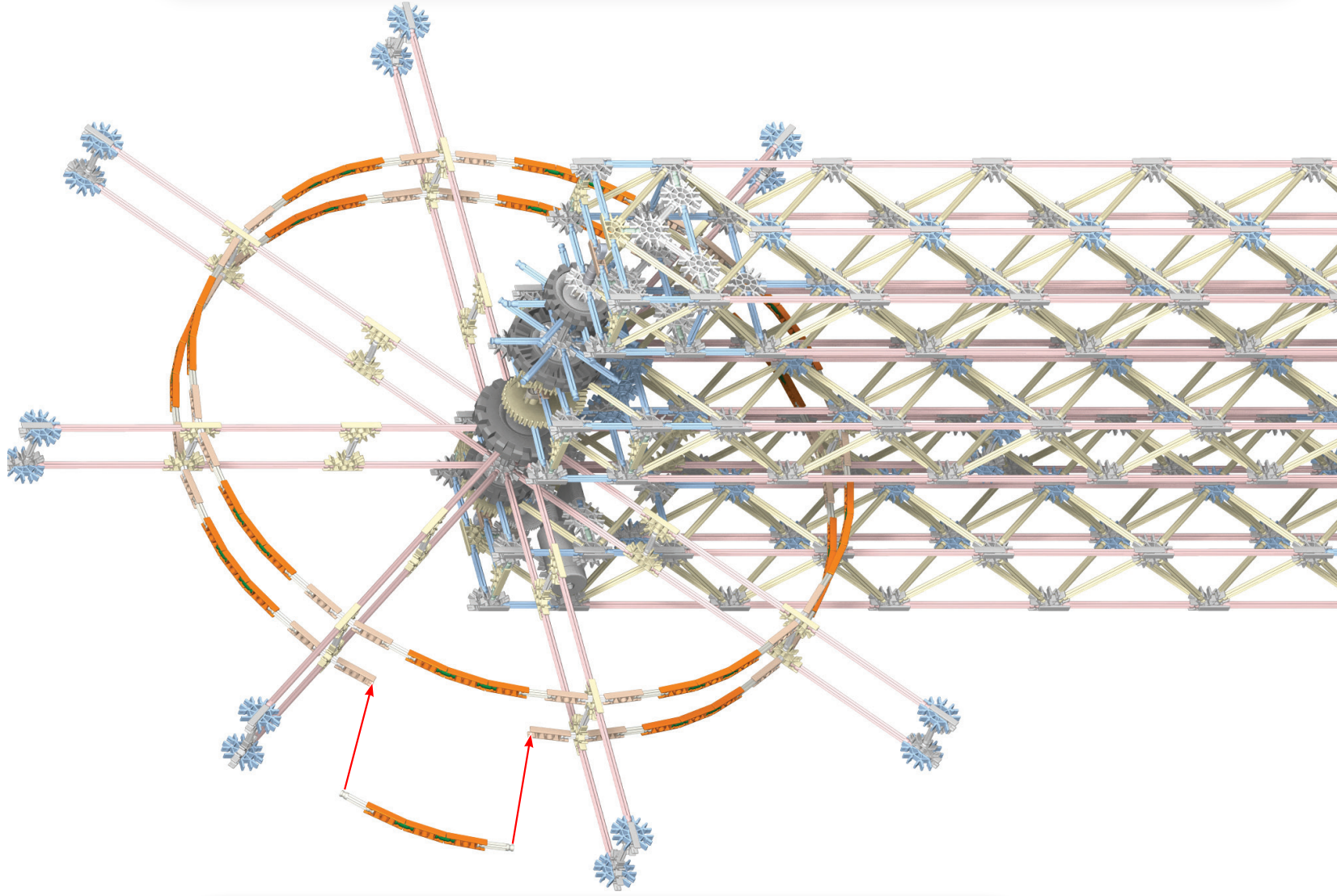

1

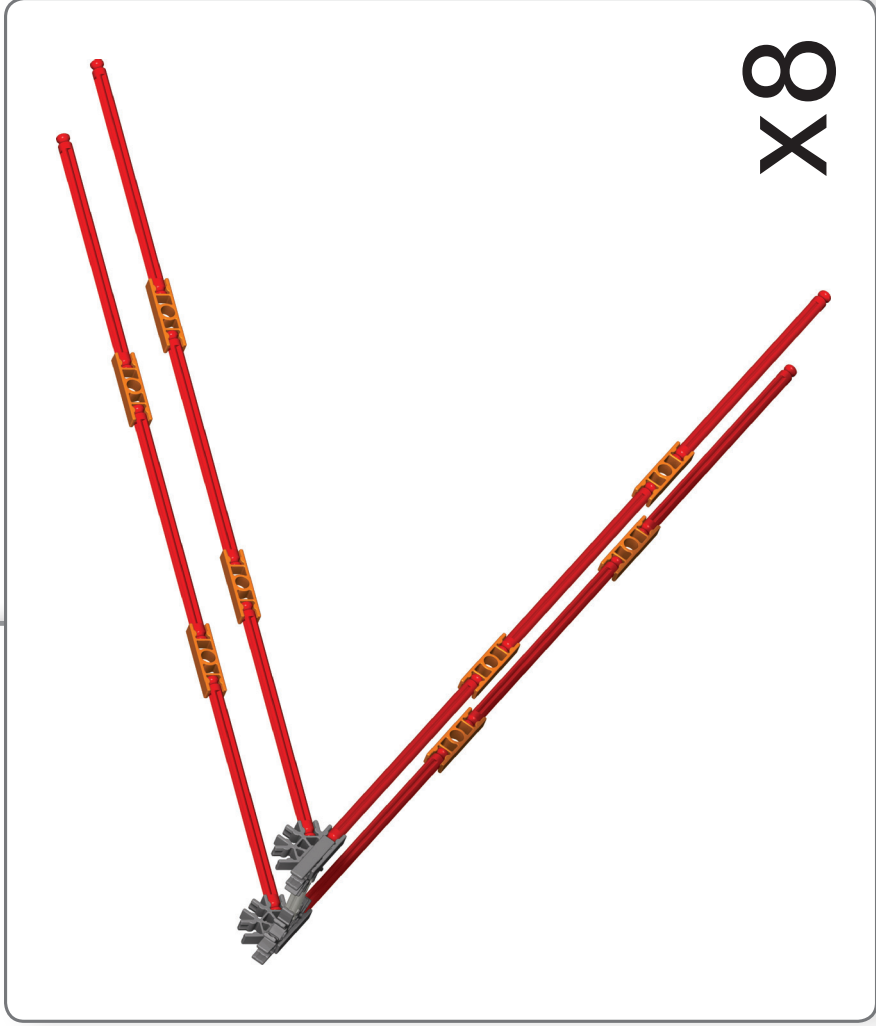
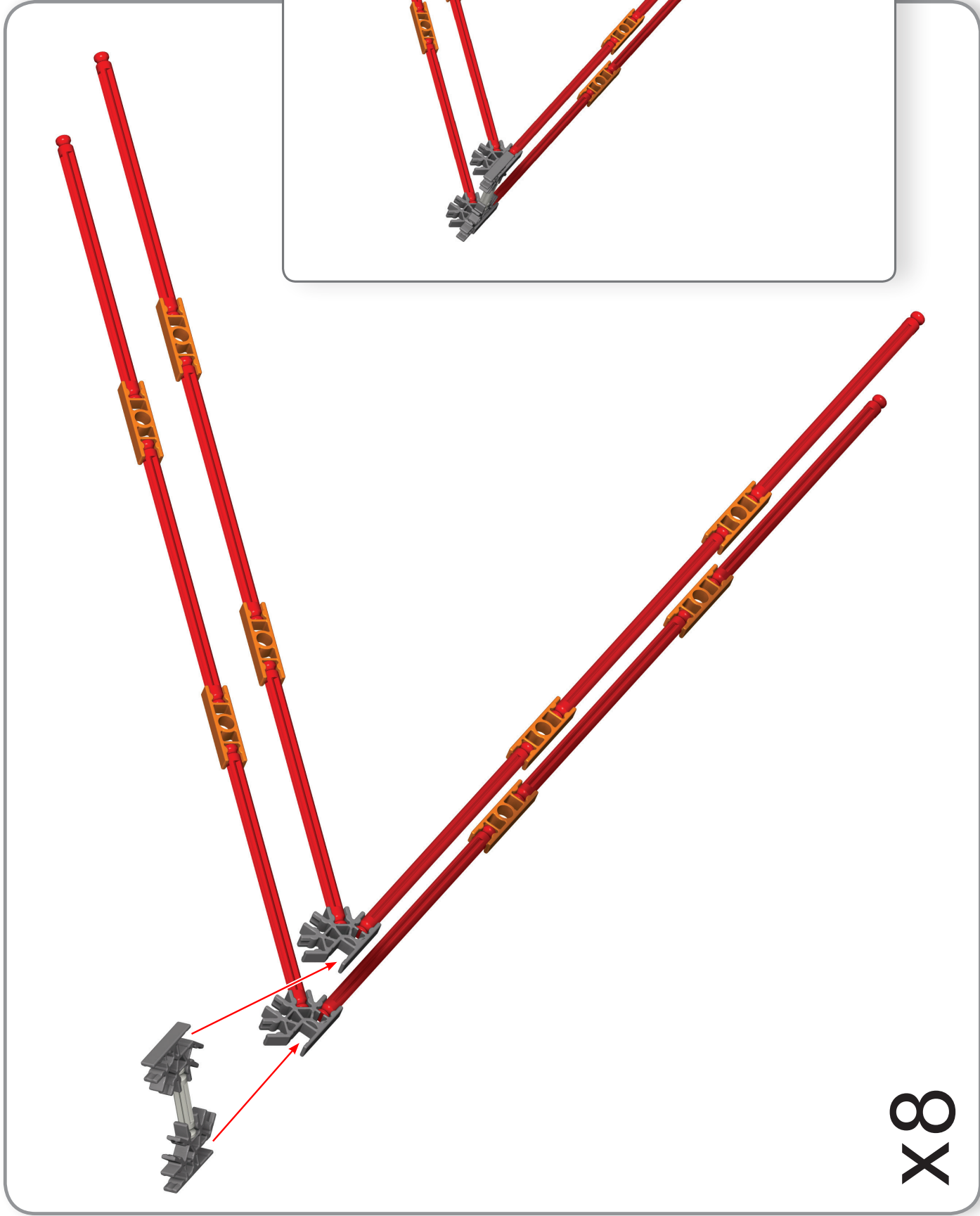

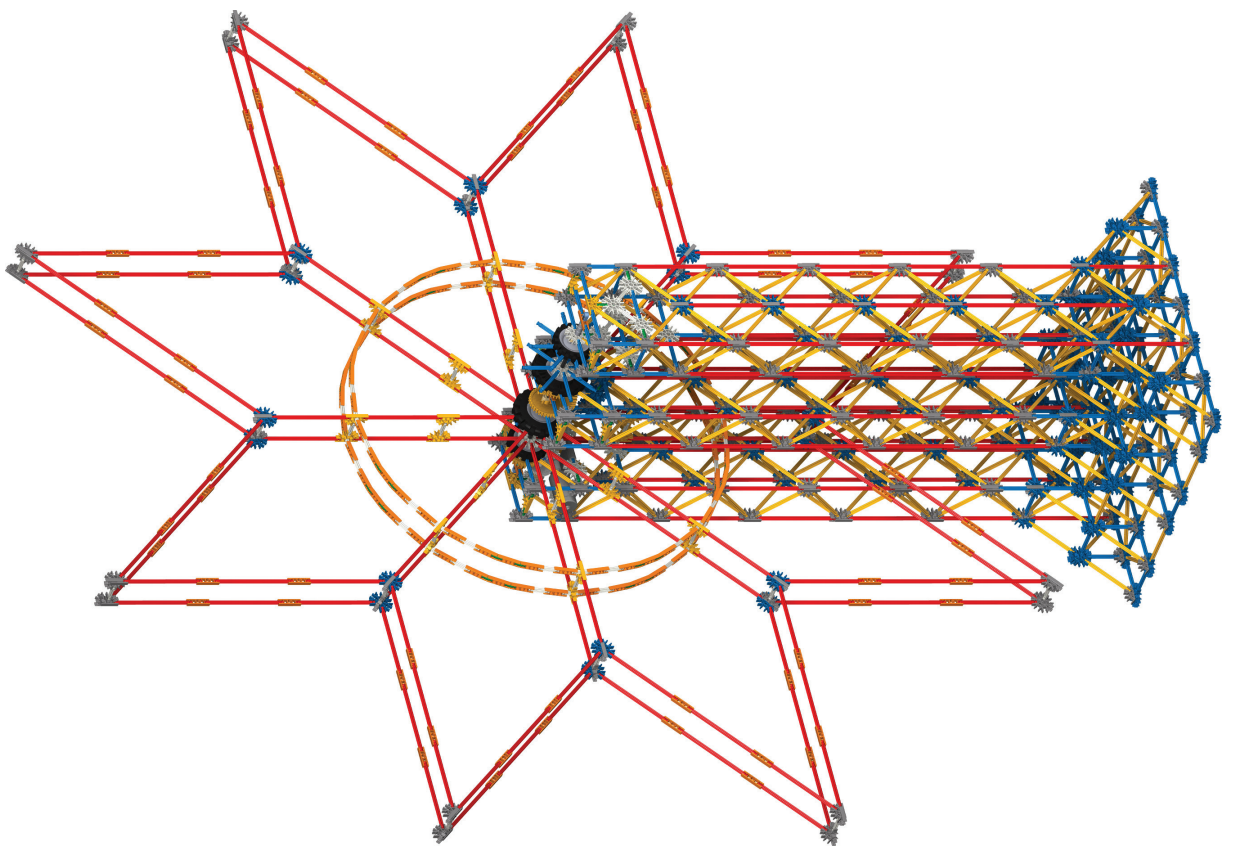
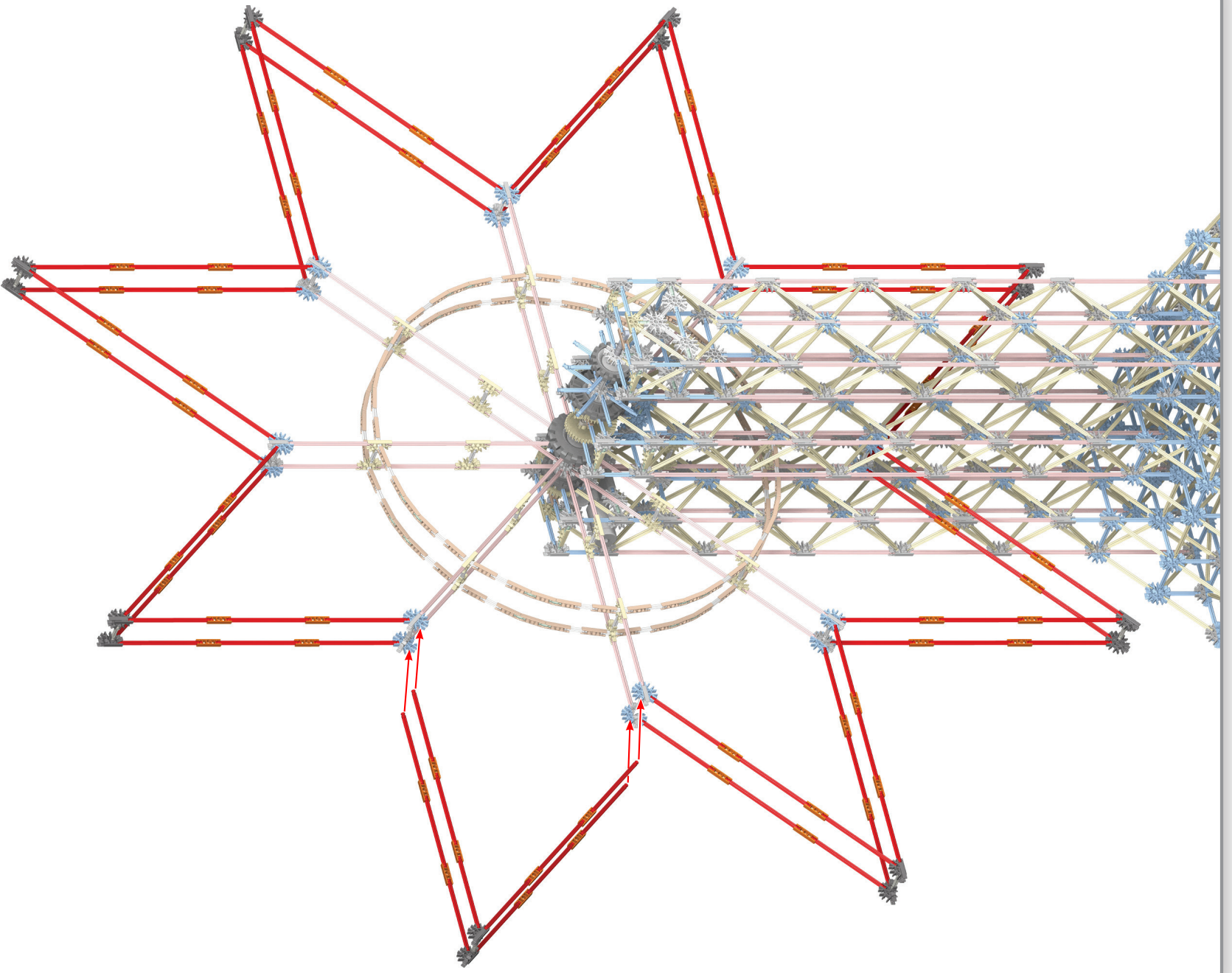

X8

**(EN) Important Tip:**  
 First put together all the 2 Connector parts that are listed below before you start to build the section on this page.

**(FR) Conseil important :**  
 Assemblez d'abord tous les éléments à 2 connecteurs qui sont indiqués ci-dessous avant de vous mettre à construire la section figurant sur cette page.

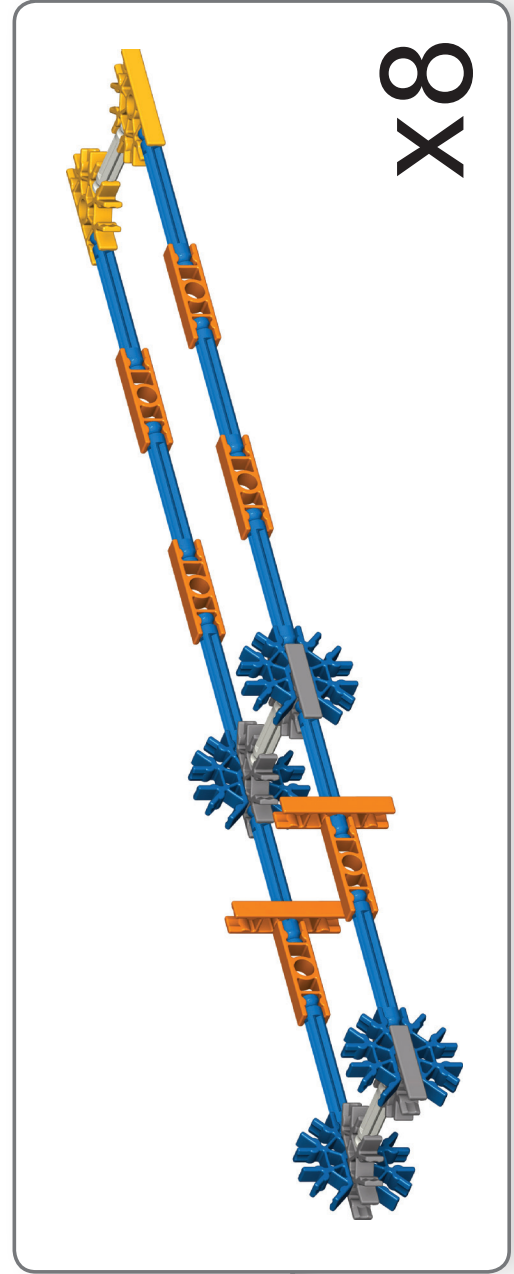
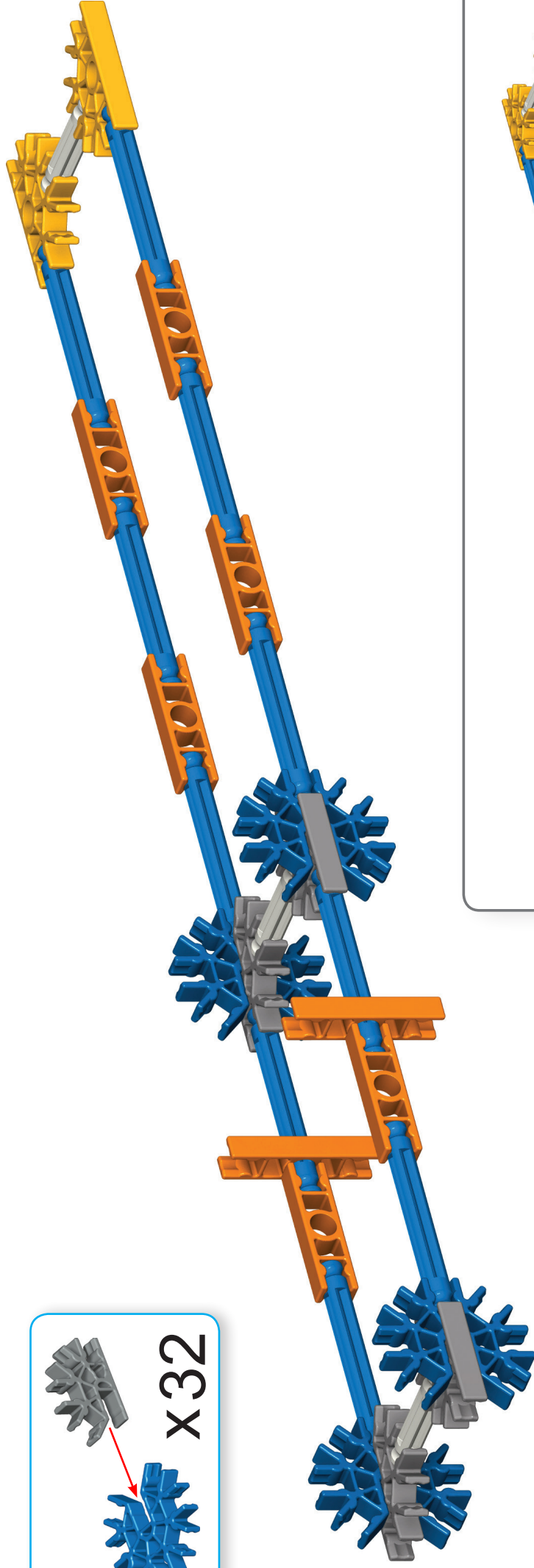
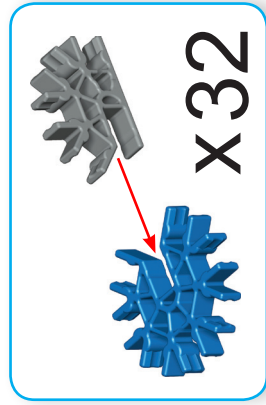

X8

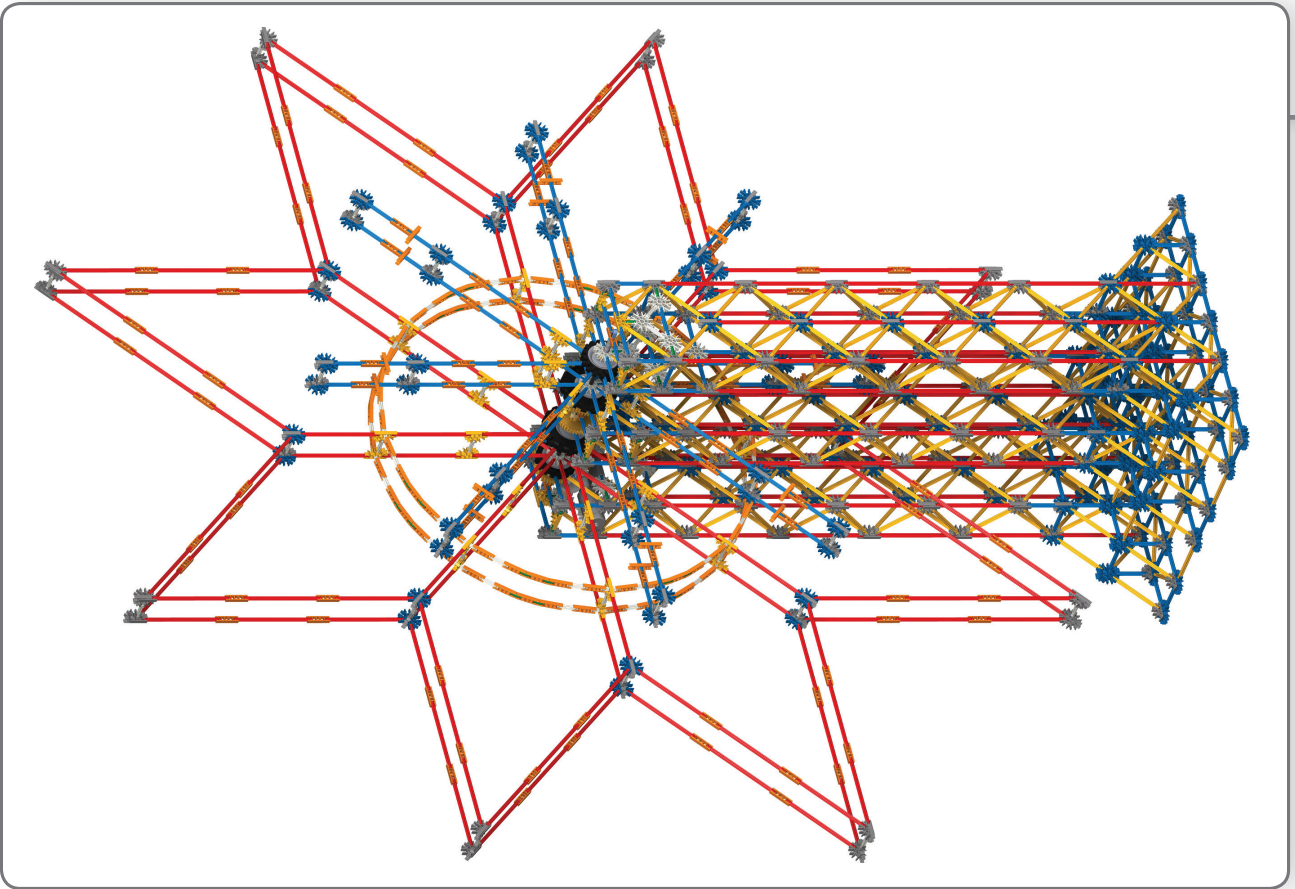
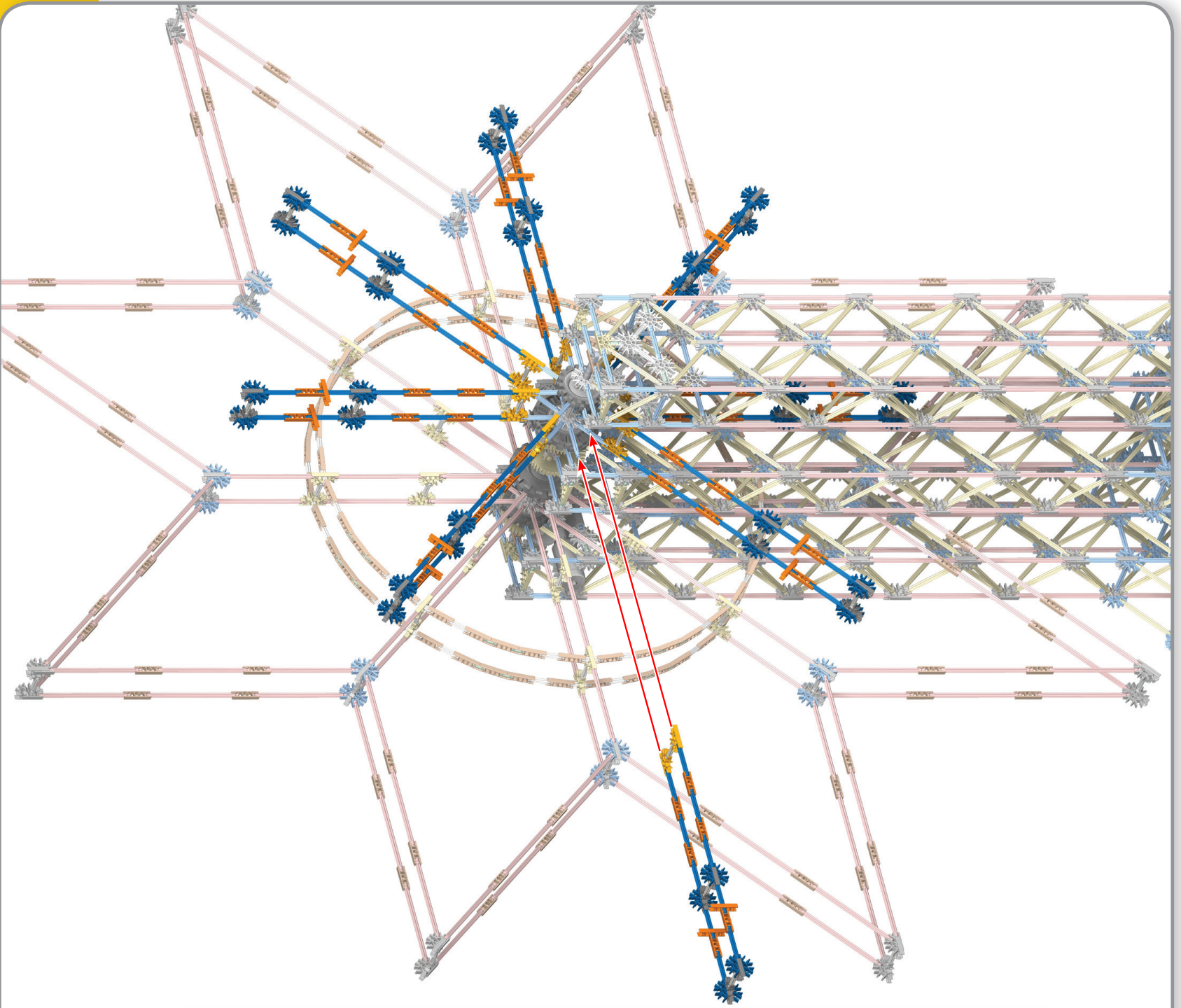

J

K

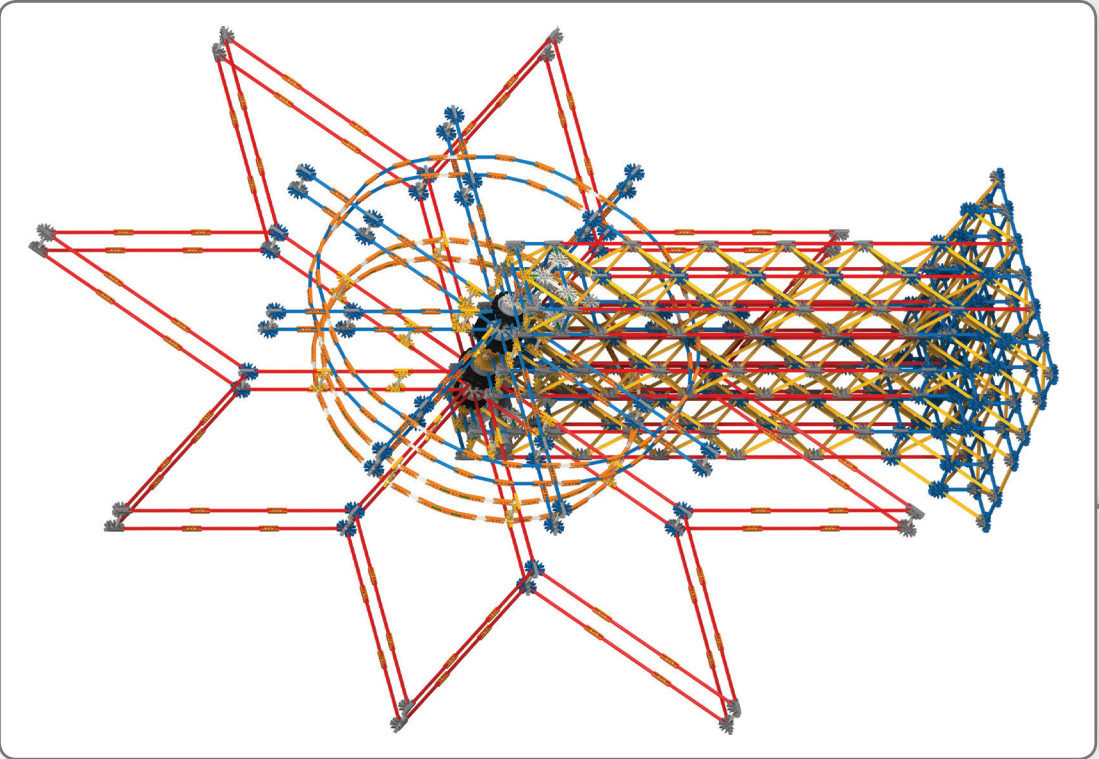
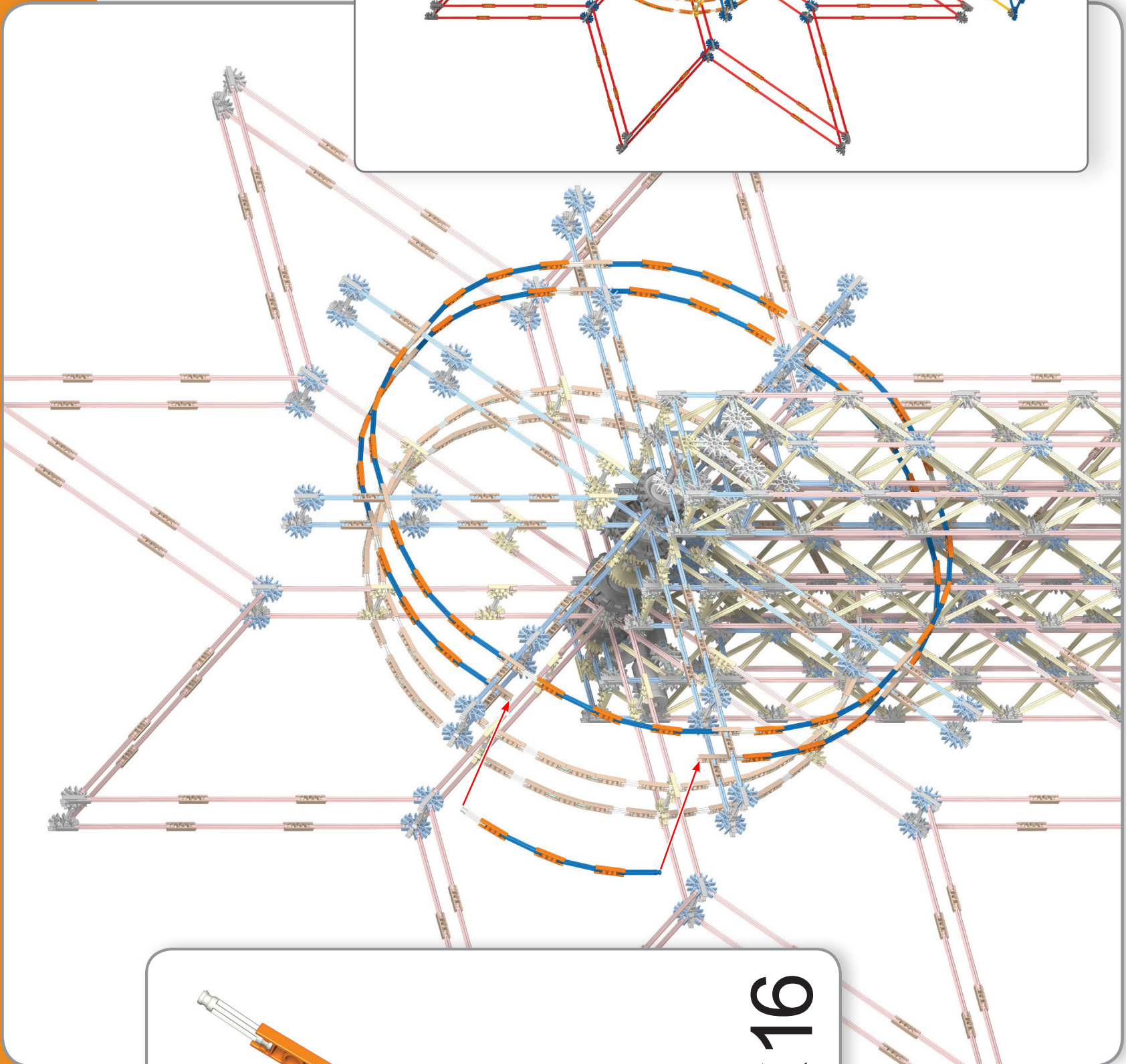
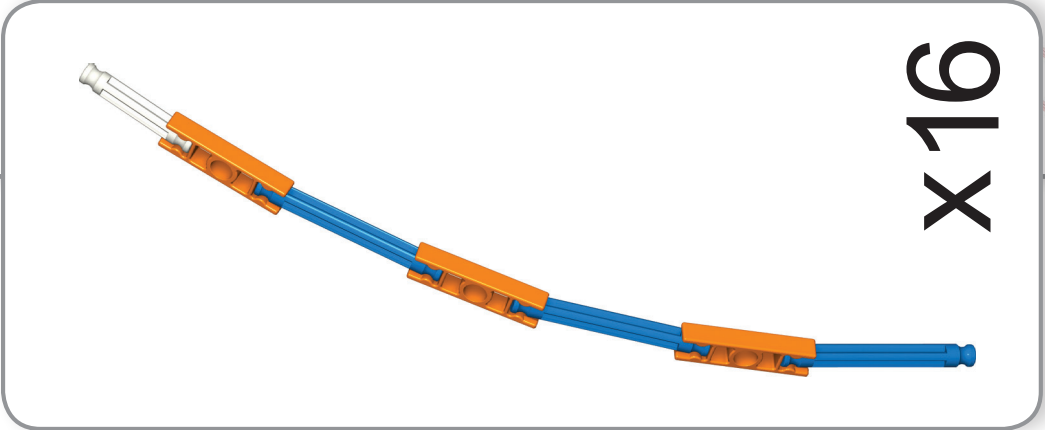

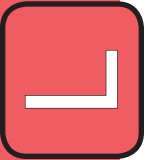

X8



**Important Tip:**

Use 2 white Rods to attach the K'NEX sign.

**Conseil important :**

Utilisez 2 tiges blanches pour fixer l'emblème K'NEX.

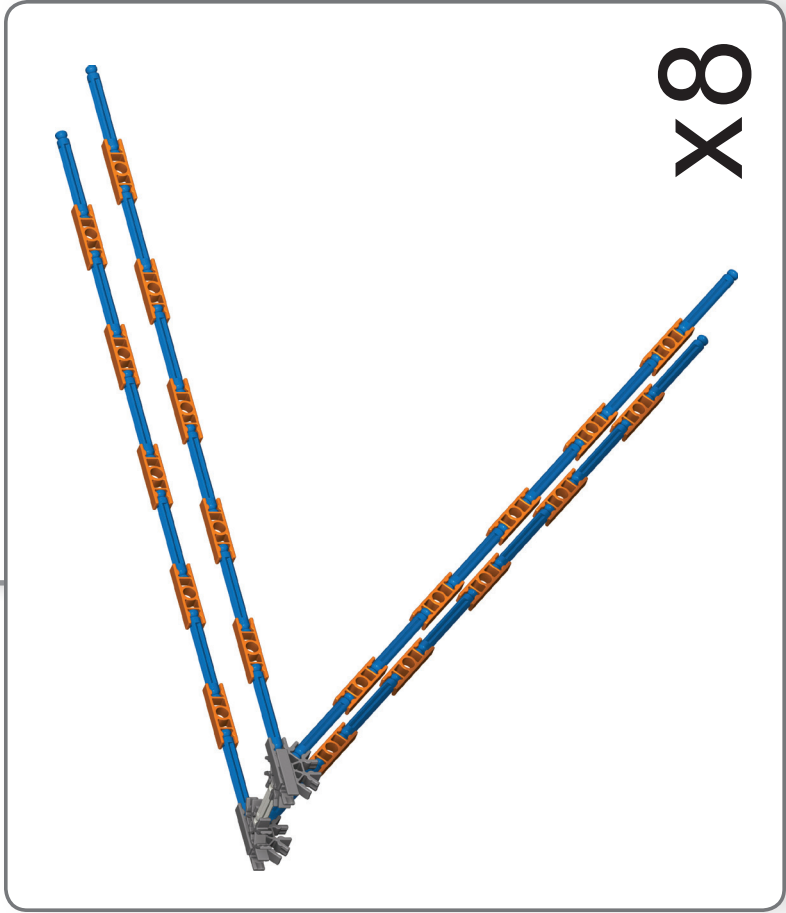
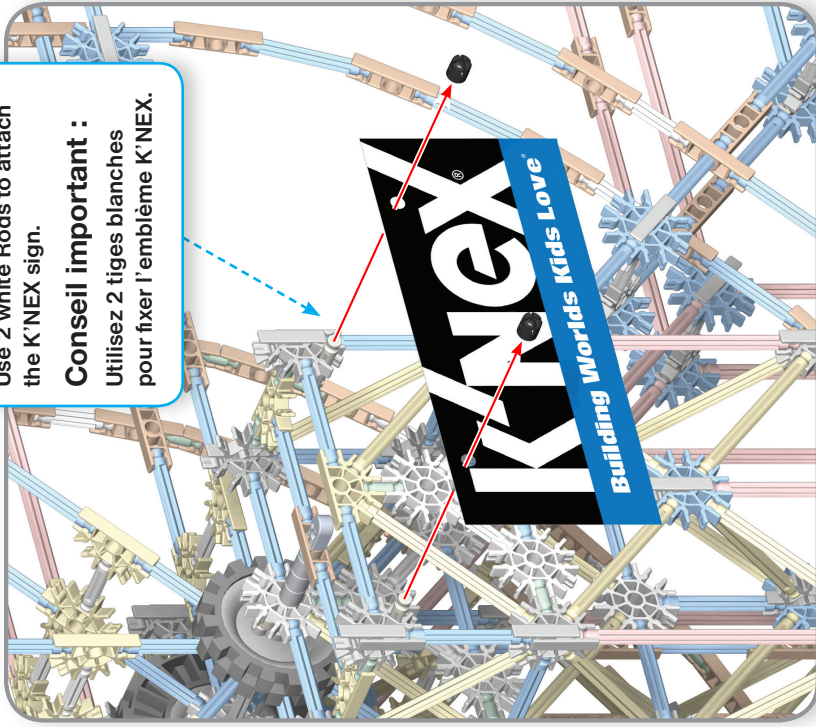

X8

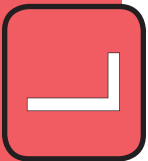
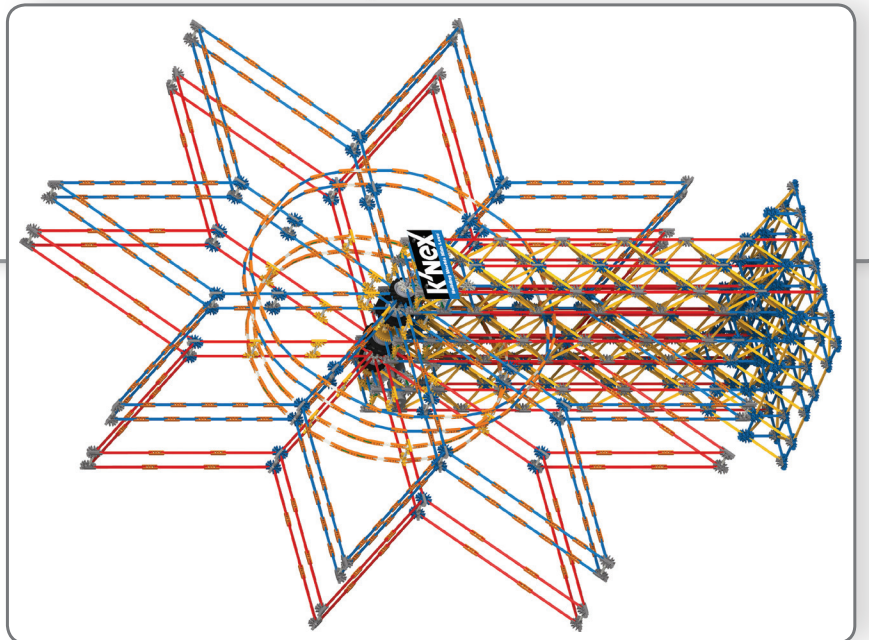
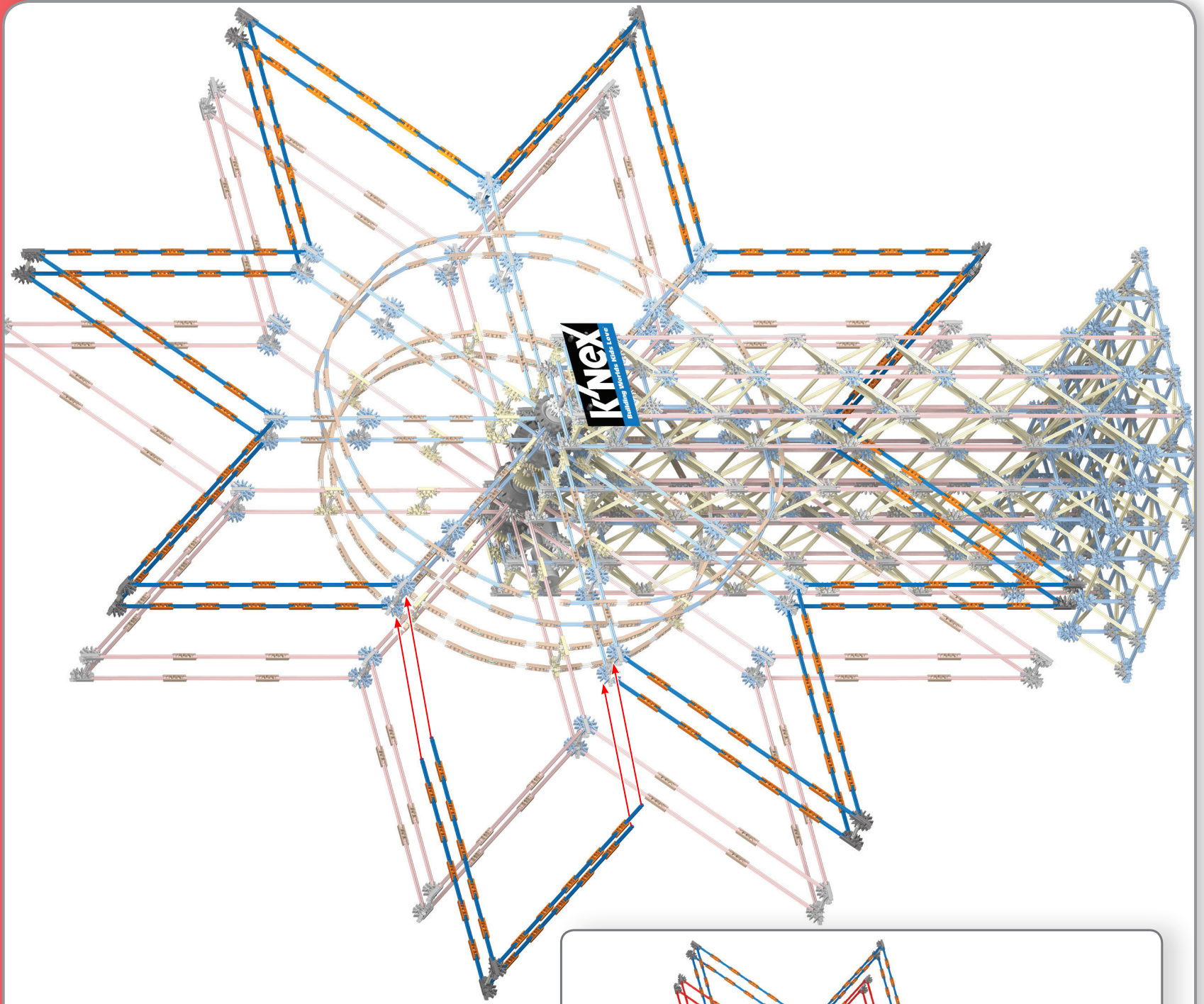

©2014 K'NEX Limited Partnership Group, P.O. Box 700, Hatfield, PA 19440-0700; 1-800-KID-KNEX (USA/Canada/États-Unis/EE.UU.); email@knex.com; knex.com. K'NEX and Building Worlds Kids Love are registered trademarks of K'NEX Limited Partnership Group. Product and colors may vary. For customers outside the USA/Canada please contact your local distributor at [www.knex.com/distributors](http://www.knex.com/distributors). (FR) K'NEX et Building Worlds Kids Love sont des marques déposées de K'NEX Limited Partnership Group. Produits et couleurs peuvent varier. Pour les clients en dehors du Canada et des États-Unis, veuillez contacter votre distributeur local que vous pouvez trouver sur [www.knex.com/distributors](http://www.knex.com/distributors). (ES) K'NEX y Building Worlds Kids Love son marcas registradas de K'NEX Limited Partnership Group. El producto y los colores pueden variar. El cliente que no vive en EE.UU./Canadá se pone en contacto con el distribuidor local en [www.knex.com/distributors](http://www.knex.com/distributors). (UK) K'NEX UK Ltd., P.O. Box 3083, Reading RG1 9YQ, England.

**KNEX.COM**

**f** [facebook.com/buildknex](https://facebook.com/buildknex)

93543-V4-10/14

