

K'NEX[®]

13122 / 23122

K-FORCE DEFENSE STATION

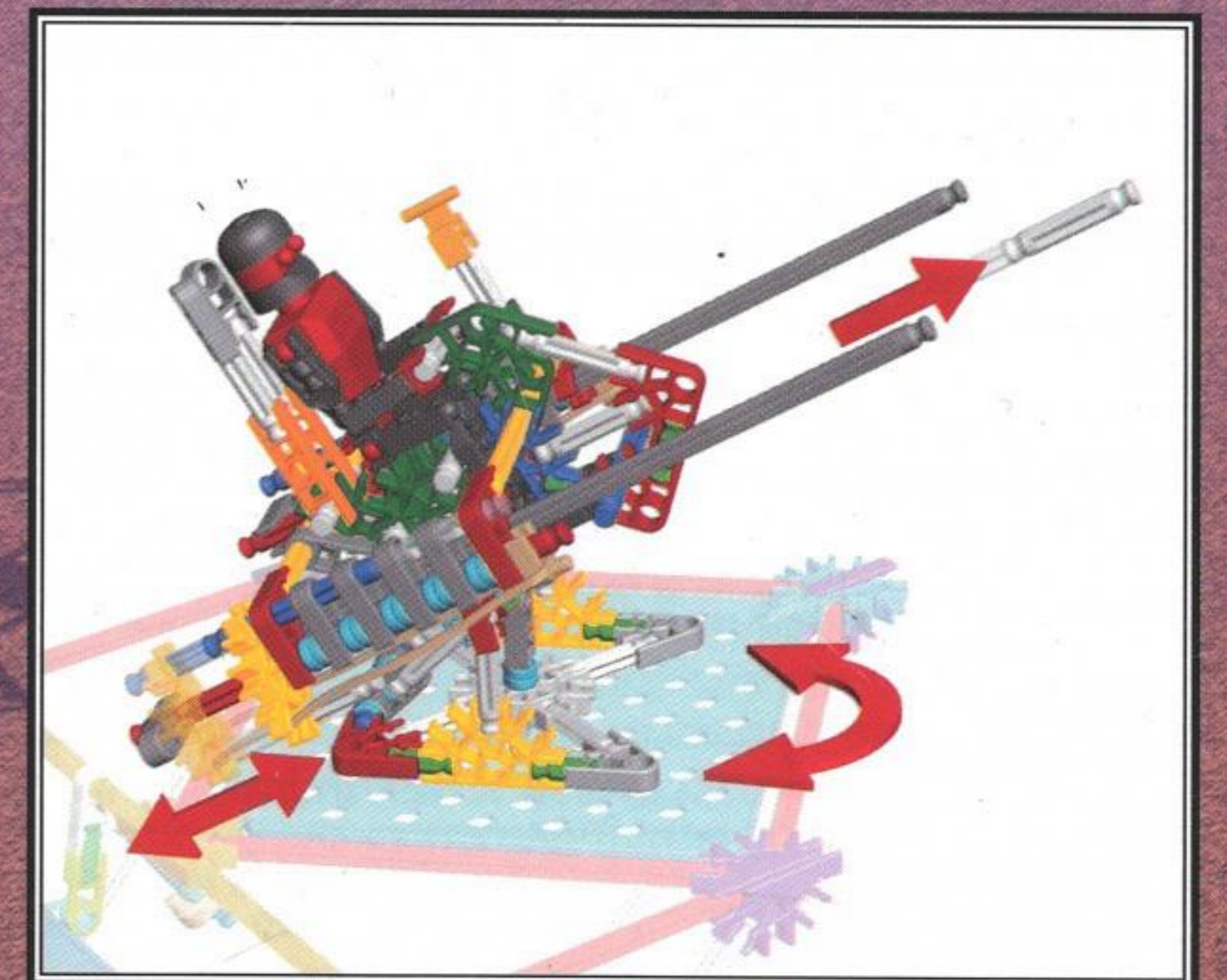
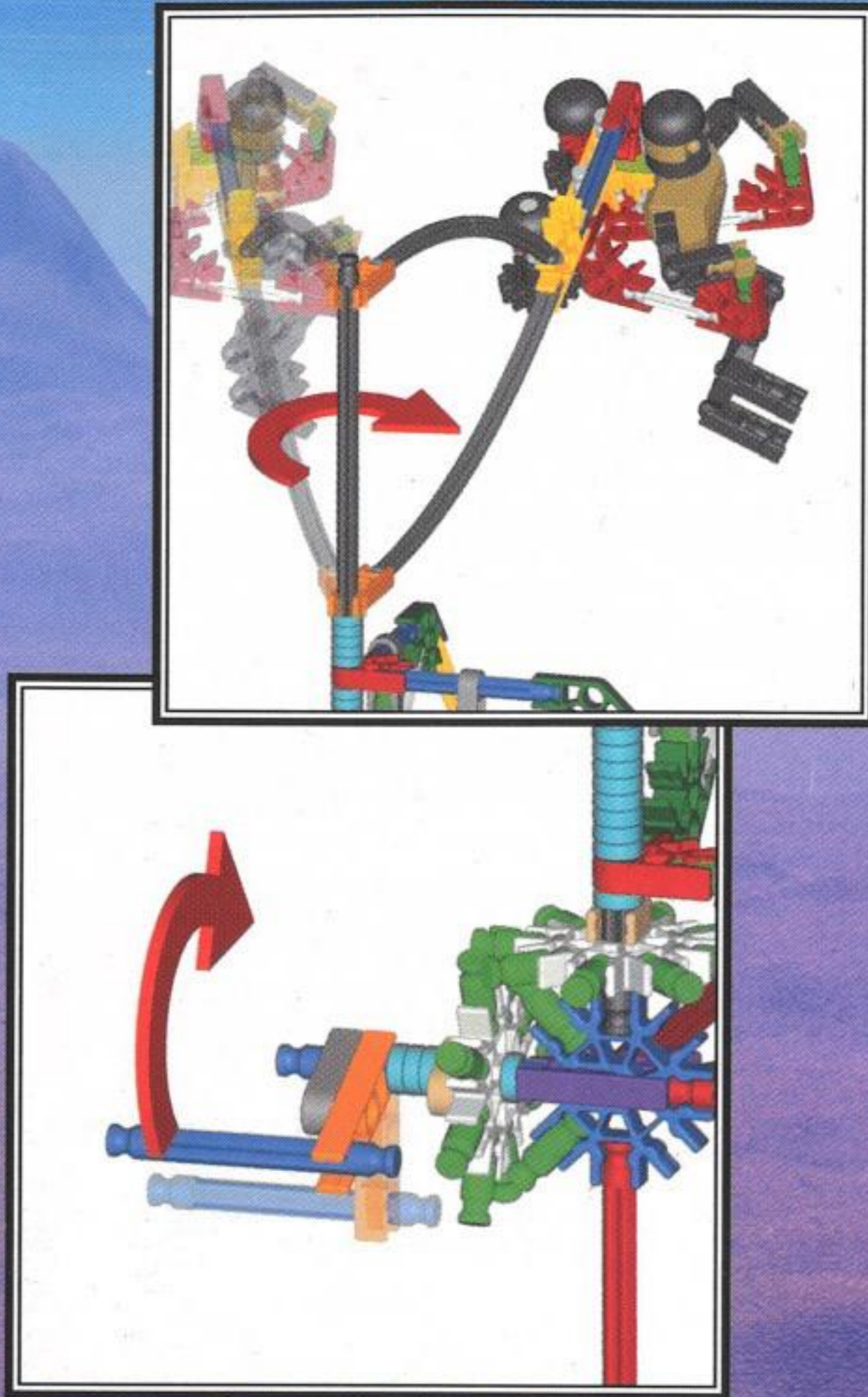

- USA (GB)** Contains small parts. Not suitable for children under the age of 3 years.
- F** Contient des pièces de petite taille. Ne convient pas aux enfants de moins de 3 ans.
- I** A causa dei suoi piccoli componenti, questo giocattolo non è adatto a bambini di età inferiore ai 3 anni.
- D** Enthält kleine Teile und ist daher nicht für Kinder unter 3 Jahren geeignet.
- E** Debido a la presencia de piezas pequeñas, no se recomienda su uso para menores de 3 años.
- S** Innehåller smådelar. Ej lämpligt för barn under 3 år.
- DK** Ikke egnet for børn under 3 år pga. smådele.
- N** Inneholder smådeler. Egner seg ikke for barn under 3 år.
- SF** Varoituu! Ei sovellu alle 3-vuotiaille lapsille. Sisältää pieniä osia.
- NL** Bevat kleine onderdelen. Niet geschikt voor kinderen jonger dan 3 jaar.
- P** Devido às dimensões reduzidas de algumas peças, não é recomendado para crianças de idade inferior a 3 anos.
- G** Λόγω των μικρών εξαρτημάτων που περιέχουν, δεν είναι κατάλληλα για παιδιά μικρότερα των 3 ετών.
- TR** Küçük parçalardan dolayı 3 yaşından küçük çocuklar için uygun değildir.
- J** 細かい部品がありますので、3才以下のお子様には適しません。
- CHI** 内含極小零件，不適合3歲以下孩童。
- IL** מאחר והערכה מכילה חלקים קטנים, היא אינה מתאימה לילדים מתחת לגיל 3.

! WARNING:
CHOKING HAZARD – Small Parts.
Not for Children under 3 years.



! AVERTISSEMENT!
Danger d'étouffement. Pièces de petite taille.
Ne pas donner aux enfants de moins de 3 ans.

GB K'NEX is a registered trademark of K'NEX Industries, Inc. K'NEX International, Century House, Station Way, Cheam, Surrey, SM3 8SW, United Kingdom. FREEPHONE 0800 834938 (UK only)

F K'NEX est une marque déposée de K'NEX Industries, Inc. K'NEX France, ZA de la Plaisse, 73370 Le Bourget-du-Lac. Hasbro (Schweiz) AG, Alte Bremgartenstrasse 2, CH-8965 Berikon and S.A. Hasbro N.V., Riverside Business Park - Spey House, Bld International 55/4 Internationale Laan, Bruxelles 1070 Brussel.

I K'NEX è un marchio di fabbrica registrato della K'NEX Industries, Inc.

D K'NEX ist ein eingetragenes Warenzeichen der K'NEX Industries, Inc. K'NEX GmbH, Waldstraße 49, 90763 Fürth. Hasbro (Schweiz) AG, Alte Bremgartenstrasse 2, CH-8965 Berikon.

E K'NEX es una marca registrada de K'NEX Industries, Inc. Distribuido en España por M.B. España S.A. Apartado de Correos 133 Quart de Poblet-Valencia. N.I.F. A-46156444; R.I. 6170. Los colores de los componentes pueden diferir de los indicados en la caja. Recomendamos que guarde nuestra dirección por si le es necesaria más adelante.

S K'NEX är ett registrerat varumärke av K'NEX Industries, Inc. Hasbro Sweden AB, Johanneslundsvägen 2, Business Campus, S-194 81 Upplands Väsby.

DK K'NEX er et registreret varemærke, der tilhører K'NEX Industries, Inc. Hasbro Denmark A/S, Ejby Industrivej 40, DK-2600 Glostrup.

N K'NEX er et registrert varemerke som tilhører K'NEX Industries, Inc. Hasbro Norway AS, Nye Vakås Vei 64, N-1360 Nesbru.

SF K'NEX on K'NEX Industries, Inc. rekisteröimä tavaramerkki. Hasbro Finland OY, Vattuniemenranta 2, SF-00210 Helsinki.

NL K'NEX is een handelsmerk van de K'NEX Industries, Inc. Hasbro B.V., Smart Business Park, Kanaalweg 16 G, 3526 KL Utrecht. S.A. Hasbro N.V., Riverside Business Park - Spey House, Bld International 55/4 Internationale Laan, Bruxelles 1070 Brussel.

P K'NEX é uma marca registada da K'NEX Industries, Inc. Distribuido em Portugal por HASBRO, IMPORTAÇÃO e EXPORTAÇÃO DE JOGOS E BRINQUEDOS LDA, Rua Melo e Sousa, Bloco 2, Estoril Garden, 2765 Estoril. NIF 502949546. As cores dos componentes podem diferir das indicadas na caixa. Recomendamos que anote a nossa morada para futura referência.

USA (GB) Caution: Rubber Bands can cause injury from snap-back, breaking, or loss of control. While assembling models shown in instructions, hold rubber band tightly, and do not overstretch. Use Rubber Bands only as shown in these instructions. DO NOT USE FRAYED OR TORN RUBBER BANDS.

F Attention: les élastiques peuvent causer des blessures en claquant, en se cassant ou quand on les manipule imprudemment. Tenez fermement l'élastique lors de l'assemblage du modèle en veillant à ne pas trop le tendre. N'utilisez les élastiques que selon les instructions. N'UTILISEZ PAS D'ÉLASTIQUES ÉRAILLÉS OU DÉCHIRÉS.

I Attenzione: gli elastici possono provocare infortuni se scattano indietro improvvisamente, in caso di rottura o se ne perde il controllo. Nel montare i modelli mostrati nelle illustrazioni tenere saldamente gli elastici, facendo attenzione a non tenderli troppo. Gli elastici vanno usati soltanto nel modo mostrato nelle illustrazioni. NON USARE ELASTICI CONSUMATI O STRAPPATI.

D Vorsicht: Gummibänder können Verletzungen hervorrufen, wenn sie reißen, zurückspringen oder wenn sie nicht vorsichtig gehandhabt werden. Halten Sie die Gummibänder während des Zusammenbaus der Modelle fest, ohne sie jedoch zu überdehnen. Verwenden Sie die Gummibänder gemäß den Anweisungen. VERWENDEN SIE NIEMALS AUSGEFRANSTE ODER ZERRISSENE GUMMIBÄNDER.

E Precaución: Las gomas pueden causar daños si se sueltan con fuerza, se rompen o se pierde su control. Al construir los modelos que se muestran en las instrucciones, sujetar bien la goma y no estirarla demasiado. Las gomas deben usarse únicamente como se indica en las instrucciones. NO USAR GOMAS QUE ESTÉN DESGASTADAS NI RASGADAS.

S OBS! Gummiband kan orsaka skada om de snäpper, går sönder eller lossnar. Håll hårt i gummibandet och sträck inte ut det för mycket vid montering av modellerna i anvisningarna. Använd gummiband endast i enlighet med dessa anvisningar. ANVÄND EJ SLITNA ELLER SKADADE GUMMIBAND.

DK Forsigtig: Gummibånd kan forårsage personskade, hvis de springer tilbage, går i stykker eller springer af. Når modellerne samles efter instruktionerne, skal man holde gummibåndene stramme, men ikke strække dem for meget. Gummibåndene må kun bruges, som anvist. BRUG ALDRIG SLIDTE ELLER BESKADIGEDE GUMMIBÅND.

N Forsiktig! Gummistrikk kan forårsake skader hvis de spretter tilbake, ryker eller løsner. Når du setter sammen modellene som vist i instruksjonene, skal du holde gummistrikken stramt men ikke strekke den for mye. Gummistrikkene skal kun brukes som vist i disse instruksjonene. BRUK IKKE GUMMISTRICK SOM ER SLITT ELLER SKADET.

SF Huomaa: Kuminauhat voivat aiheuttaa tapaturman katketessaan tai irrotessaan. Kun rakennat ohjeissa esitettyjä malleja, pidä tiukasti kiinni kuminauhasta äläkä venytä sitä liikaa. Käytä kuminauhoja ainoastaan ohjeissa esitetyllä tavalla. ÄLÄ KÄYTÄ HAURASTUNEITA TAI REPEUTUNEITA KUMINAUHOJA.

NL Let op: De elastiekjes kunnen letsel veroorzaken door terugklappen, breken of doordat je er de controle over verliest. Bij het inelkaar zetten van de modellen het elastiekje stevig vasthouden en het niet te ver uitrekken. De elastiekjes uitsluitend gebruiken zoals in deze aanwijzingen aangegeven. GEEN ELASTIEKJES MET RAFELS OF SCHEUREN GEBRUIKEN.

P Atenção: As borrachas poderão causar ferimentos ao serem esticadas, ao quebrarem ou ao perderem controle. Ao montar os modelos mostrados nas instruções, segure bem a borracha e não a estique demasiado. Utilize as borrachas apenas da forma exemplificada nestas instruções. NÃO UTILIZE BORRACHAS CORROÍDAS OU QUEBRADAS.

G Προσοχή: Τα λαστιχάκια μπορεί να προκαλέσουν τραυματισμό όταν εκτοξεύονται μετά από τράβηγμα, σπάσιμο ή όταν ξεφεύγουν από τα χέρια σας. Όταν συναρμολογείτε τα μοντέλα που φαίνονται στις οδηγίες, κρατήστε το λαστιχάκι γερά και μη το τεντώνετε πολύ. Χρησιμοποιήστε τα λαστιχάκια μόνο όπως φαίνεται στις οδηγίες. ΜΗΝ ΧΡΗΣΙΜΟΠΟΙΗΤΕ ΤΡΙΜΜΕΝΑ Ή ΣΧΙΣΜΕΝΑ ΛΑΣΤΙΧΑΚΙΑ.

TR Dikkat: Lastik halkalar, aniden geriye fırlama, kopma veya kontrol kaybı/elden fırlama sebebiyle yaralanmaya yol açabilir. Açıklamada gösterilen modelleri monte ederken, lastik halkaları elinizde sıkıca tutun ve ağır bir şekilde esnetip uzatmayın. Lastik halkaları sadece bu açıklamada gösterildiği gibi kullanın. AŞINMIŞ, YIRTILMIŞ VEYA KOPMUŞ OLAN LASTİK HALKA KULLANMAYIN.

J 注意: 輪ゴムの跳ね返り、破損あるいはコントロールの喪失によりけがの原因になる場合があります。説明図の中のモデルを組み立てている時は、輪ゴムをしっかりとおさえ、伸ばし過ぎないように気をつけてください。輪ゴムは説明図に示されている場合のみにご使用ください。古い弾力性のない輪ゴムは使用しないでください。

CHI 注意事項: 橡皮圈在用力反彈、斷裂或失去控制時會造成傷害。所以在按說明組合模型時，請拉好橡皮圈，而且不要過度伸張。請只按說明使用橡皮圈。請勿使用已磨損或拉裂的橡皮圈。

IL זהירות: רצועות הגומי יכולות לגרום לפציעה במקרה שהן עפות לאחור, נקרעות או יוצאות מכלל שליטה. בעת הרכבת הדגמים המופיעים בהוראות, החזק חזק את רצועת הגומי, ואל תמתח אותה יותר על המידה. השתמש ברצועות הגומי אך ורק בהתאם להוראות. אין להשתמש ברצועות גומי פרומות או קרועות.

G Το K'NEX είναι σήμα κατατεθέν της K'NEX Industries, Inc.

TR K'NEX, K'NEX Industries, Inc.'in tescilli markasıdır. İNTERTOY tarafından ithal edilmiştir. PK 221, Şişli İstanbul.

J K'NEXは K'NEX Industries, Inc. の登録商標です。リサイクル紙使用

CHI K'NEX 是 K'NEX Industries, Inc. 的注册商標。香港九龍尖沙嘴廣東道七號海港城世運中心一五零六室 Palmyra (香港) 有限公司台灣分公司, 台北縣砂址鎮中興路九十五號五樓二室。

IL K'NEX Industries, Inc. הוא סימן מסחרי רשום של הסברו ישראל בע"מ, שדרות הרצל 104, ירושלים 96187

©1998 K'NEX Industries, Inc. • Hatfield, PA 19440-0700 • 1-800-KID-KNEX (USA & CANADA) • Visit K'NEX at www.knex.com

K'NEX is a registered trademark of K'NEX Industries, Inc. Manufactured under U.S. Patents 5,061,219, 5,137,486, 5,199,919, 5,238,438, 5,346,420, 5,350,331, 5,368,514, 5,421,762, 5,423,707, 5,427,559, 5,518,435, D389,203 and D391,1921. Other U.S. and foreign patents pending.

Conforms to the Requirements of ASTM Standard Consumer Safety Specification on Toy Safety F963-96a.

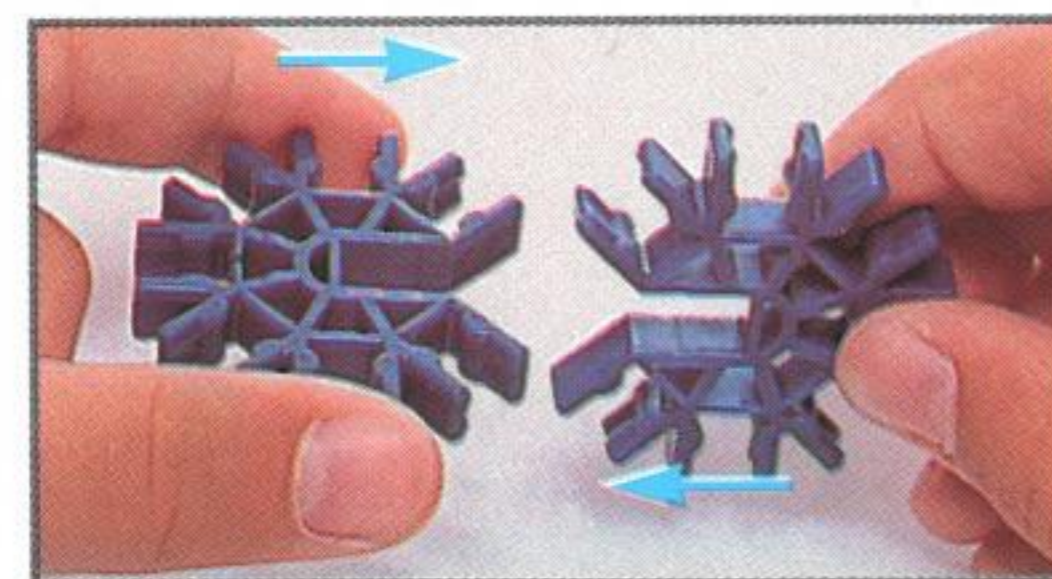
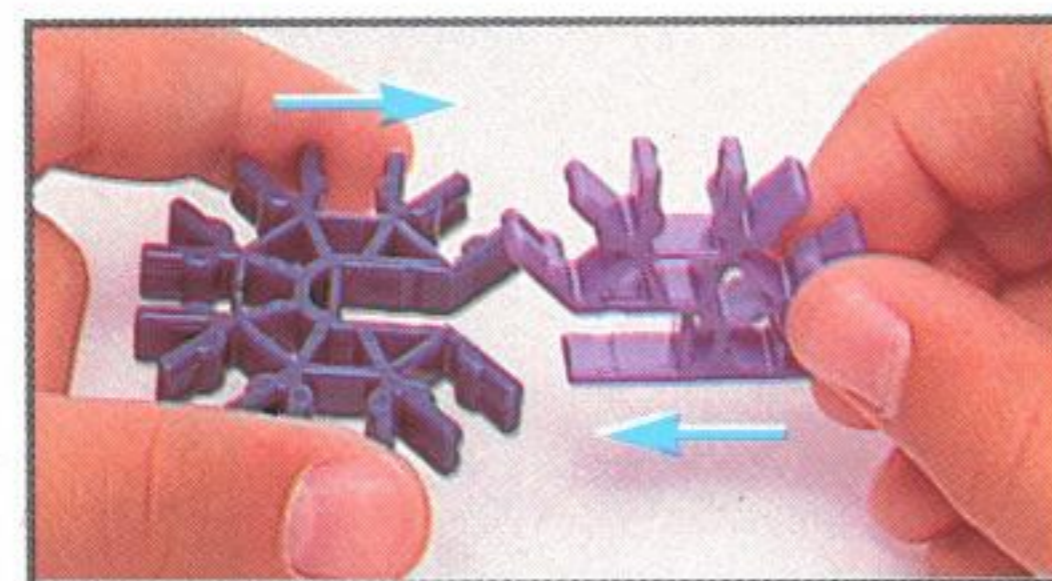
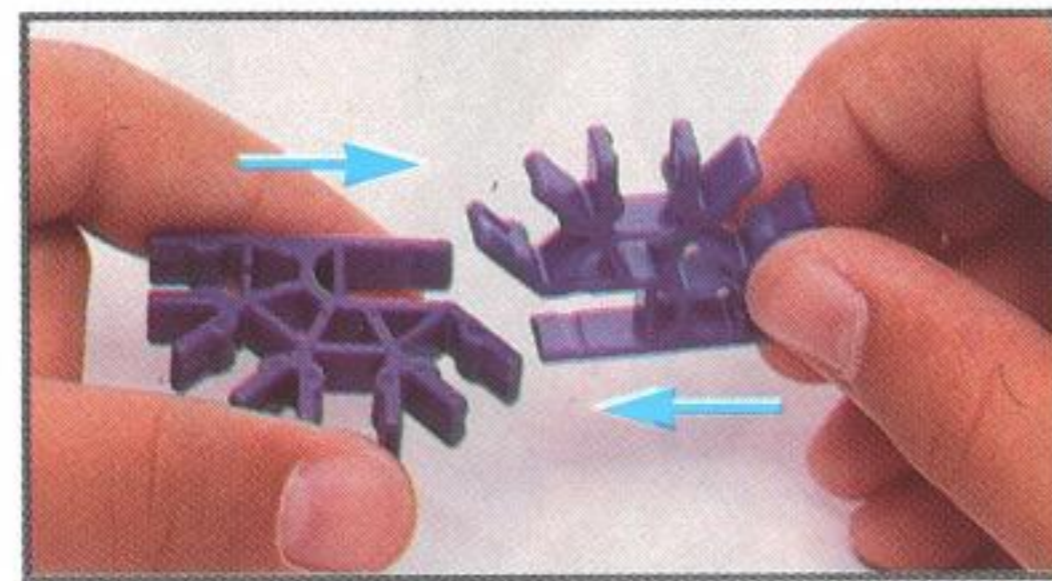
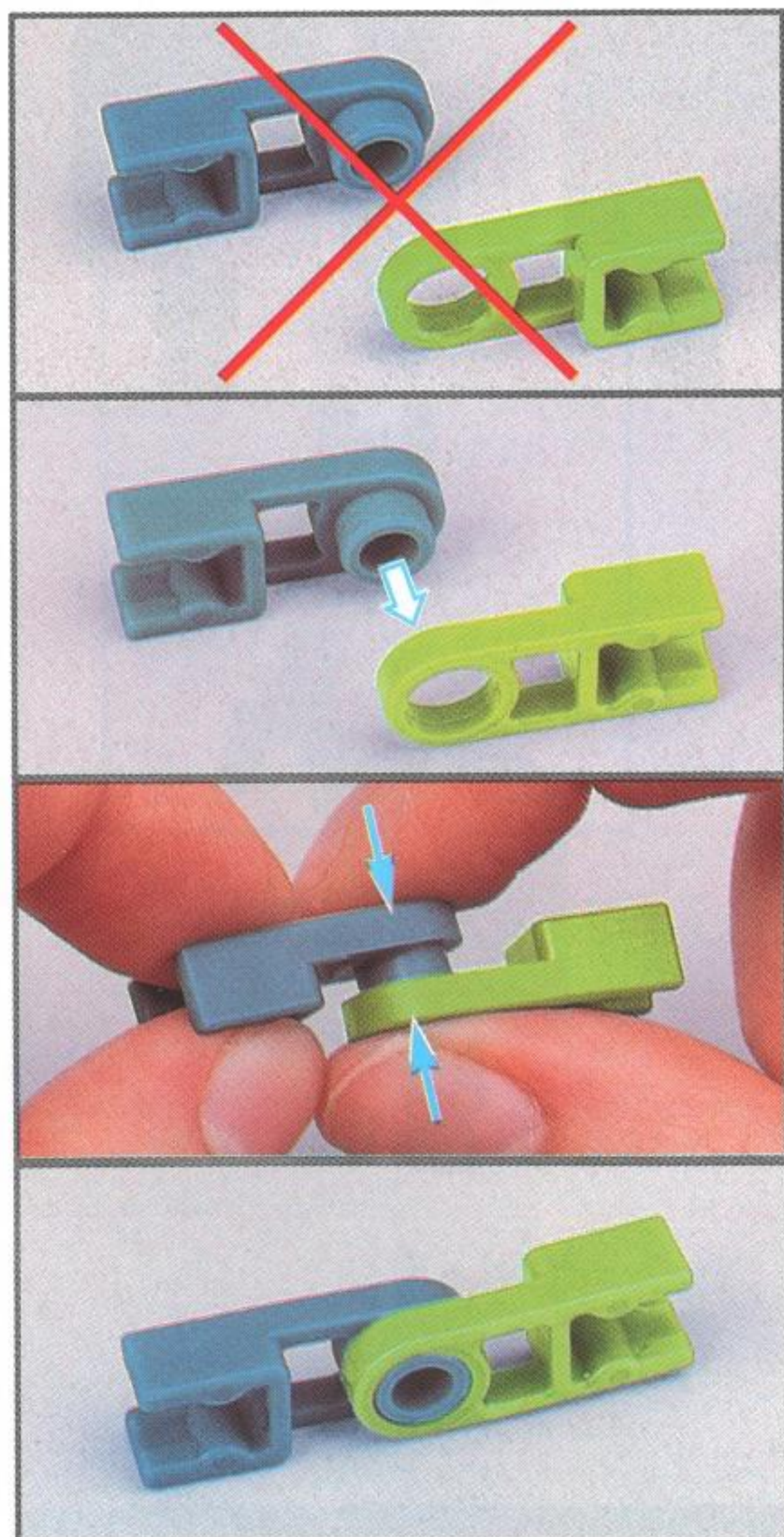
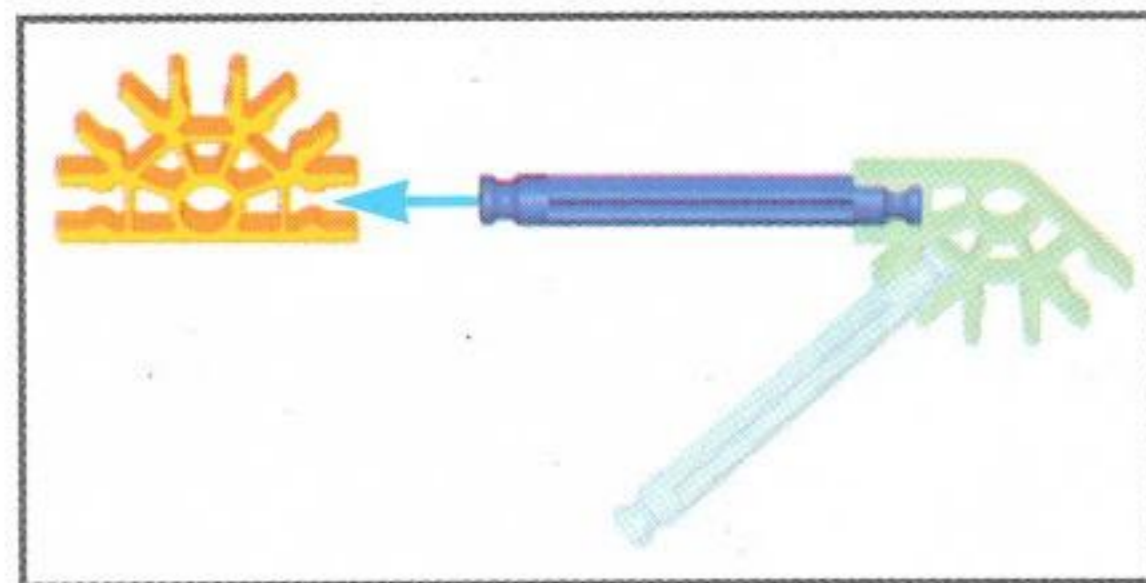

USA (GB) Each K'NEX piece has its own special color (colour) and shape; match it to pieces in the picture instructions. Put pieces together exactly as pictures show. Faded colors (colours) indicate sections previously built; points of attachment will be in full color (colour).

F Chaque élément K'NEX a une forme et une couleur qui lui sont propres. Faites correspondre et montez les éléments en vous conformant exactement aux instructions illustrées. Les couleurs plus claires correspondent aux sections déjà construites et les points de jonction sont indiqués en couleurs vives.

I Ciascun pezzo di K'NEX ha un colore ed una forma diversi; far corrispondere ciascun pezzo al corrispettivo nelle istruzioni figurate. Montare i pezzi esattamente con riportato nelle figure. I colori schiariti indicano le sezioni già assemblate; i punti di collegamento sono illustrati a colori vivi.

D Jedes K'NEX-Stück hat seine eigene besondere Farbe und Form; finden Sie die entsprechenden Stücke in der illustrierten Anleitung. Setzen Sie die Stücke genau wie auf dem Bild dargestellt zusammen. Die farblich heller gekennzeichneten Teile zeigen bereits zusammengebaute Abschnitte an; die Anbringungspunkte sind in kräftigen Farben angegeben.

E Cada pieza K'NEX tiene su propio color y forma particular; combínala con las piezas en las instrucciones ilustradas. Arma las piezas exactamente como se muestra en las ilustraciones. Los colores pálidos indican las secciones que ya se armaron y los puntos de conexión figurarán a todo color.

S Varje bit i K'NEX har sin egen färg och sin egen form; matcha den med bitarna i illustrationen till instruktionerna. Sätt ihop bitarna precis som bilden visar. Mattare färger anger sektioner som redan har byggts; monteringspunkterna kommer att vara i full färg.

N Hver K'NEX del har sin egen, spesielle farge og form, som skal koordineres med delene i bruksanvisningene med bilder. Delene må settes sammen akkurat slik som bildene viser. Bleke farger henviser til seksjoner som har blitt bygget tidligere; festepunktene vil bli fremvist i sterke farger.

DK Hvert K'NEX stykke har sin egen særlige farve og facon. Afpas stykket med vejledningen på billedet. Sæt stykkerne sammen nøjagtigt som billederne viser. Nedtonede farver indikerer afsnit, som allerede er sat sammen; samlingspunktet vises i fuld farve.

DK Hvert K'NEX stykke har sin egen særlige farve og facon. Afpas stykket med vejledningen på

billedet. Sæt stykkerne sammen nøjagtigt som billederne viser. Nedtonede farver indikerer afsnit, som allerede er sat sammen; samlingspunktet vises i fuld farve.

SF Jokaisella K'NEX-osalla on oma värinsä ja muotonsa; sovita se kuvan ohjeiden mukaan. Pane palaset yhteen kuvien osoittamalla tavalla. Haalistuneet värit osoittavat aikaisemmin rakennettuja osia; liitäntäkohdat ovat täysvärisiä.

NL Elk K'NEX onderdeel heeft zijn eigen speciale kleur en vorm; vergelijk ze met de onderdelen in de instructie-afbeeldingen. Zet de onderdelen precies volgens de afbeeldingen in elkaar. De vaal gekleurde gedeelten zijn al eerder gebouwd; de bevestigingspunten zijn in volle kleur weergegeven.

P Cada uma das peças K'NEX possui uma cor e forma próprias; compare-as com as peças após as entadas nas instruções. Monte as peças exatamente como indicado nas fotografias. As cores mais esbatidas identificam as secções já construídas; os pontos de encaixe aparecem em cores vivas.

G Κάθε κομμάτι έχει το δικό του ξεχωριστό χρώμα και σχήμα για να το ταιριάζετε με τα κομμάτια που βλέπετε στις οδηγίες. Συνδέστε τα κομμάτια όπως ακριβώς δείχνουν οι οδηγίες. Τα σβησμένα χρώματα δείχνουν τα τμήματα που έχουν ήδη κατασκευαστεί. Τα σημεία σύνδεσης φαίνονται με πιο έντονο χρώμα.

TR Her K'NEX parçasının ayrı bir şekli ve rengi vardır; onları resimli açıklamalarda gösterilenlerle eşleştirin. Parçaları aynen resimlerde gösterildiği gibi birleştirin. Soluk renkler daha önceden monte edilen kısımları gösterir; geçiş noktaları tam renkli olarak gösterilmiştir.

J K'NEXの各部品は、それぞれカラーや形状が異なります。各部品を説明図と照らし合わせて確認してください。部品は図にしたがって正しく組み合わせてください。薄いカラーで表示されている部分は、すでに組み立てられた部分です。接続する部分は、実際のカラーで示されています。

CHI 每一片 K'NEX 塑膠的顏色和形狀皆不同；請依圖片指示拼裝。完成品須與圖示一模一樣。褪色處表示先前已拼好，連接處則以鮮明顏色標示。

IL לכל חלק של K'NEX צבע וצורה מיוחדים משלו. התאם אותו לחלקים המופיעים בהוראות שבתמונות. חבר את החלקים בדיוק כפי שמראים בתמונות. צבעים דהויים מצביעים על חלקים שנבנו קודם לכן. נקודות החיבור מופיעות בצבע מלא.

Gold Commander

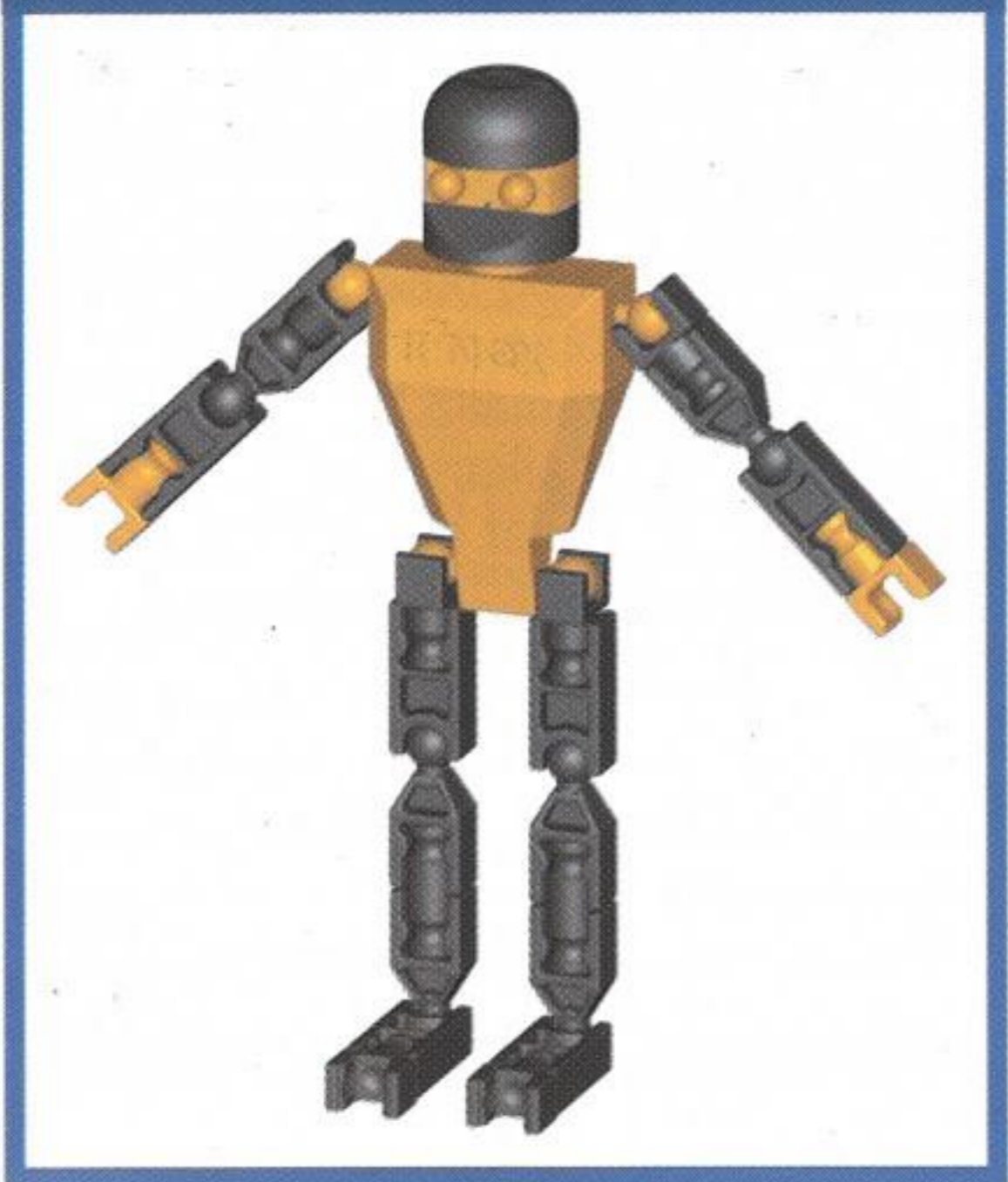

Red Team

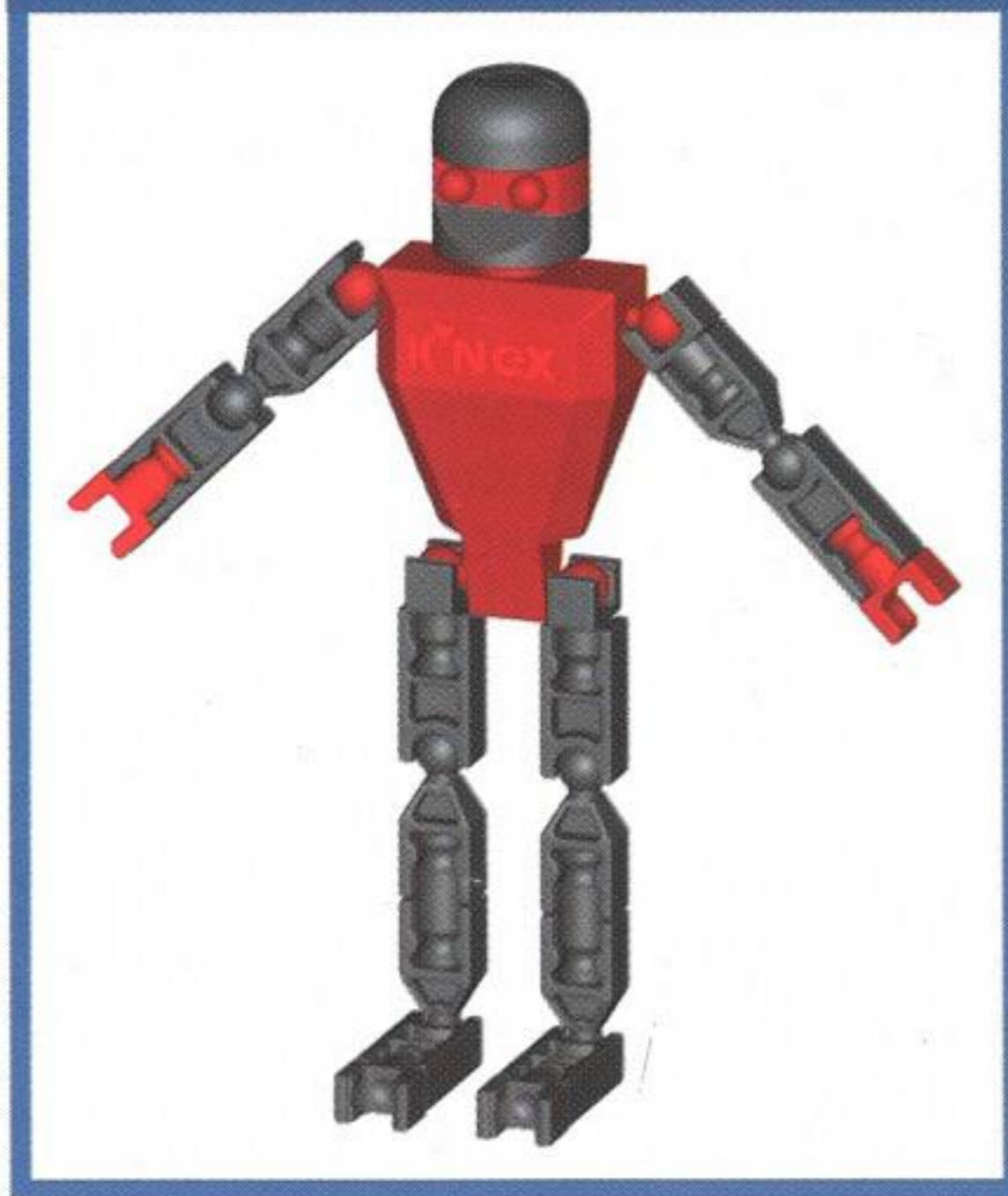

USA (GB) Options

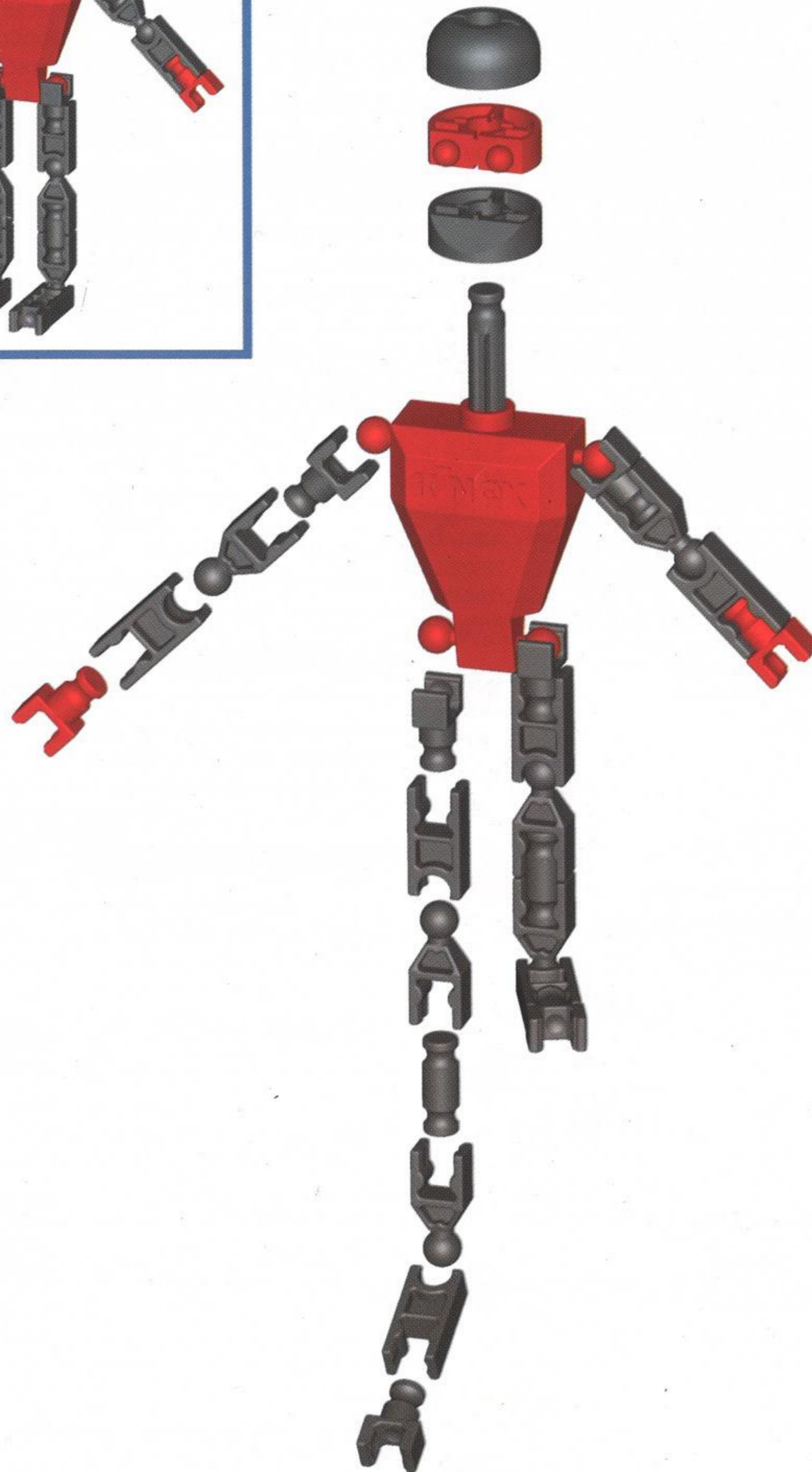

USA (GB) Push to snap together.

SF Napsauta osat kiinni toisiinsa.

F Enfoncez les pièces pour les imbriquer.

NL Druk op de onderdelen om ze in elkaar te klemmen.

I Spingere per incastrare.

P Empurre para encaixar.

D Teile zum Verbinden zusammenstecken.

G Πιέστε για να τα ενώσετε.

E Empuja las piezas para que encajen a presión.

TR İttirerek birbirbine birleştirin.

S Tryck ihop delarna tills de låses samman.

J 押しながらはめ込みます。

DK Skub delene ind i hinanden, til de siger klik.

CHI 將兩邊啪嗒一聲推在一起。

N Skyv delene mot hverandre til de låses sammen.

IL לחיבור החלקים, לחץ.



Defense Station

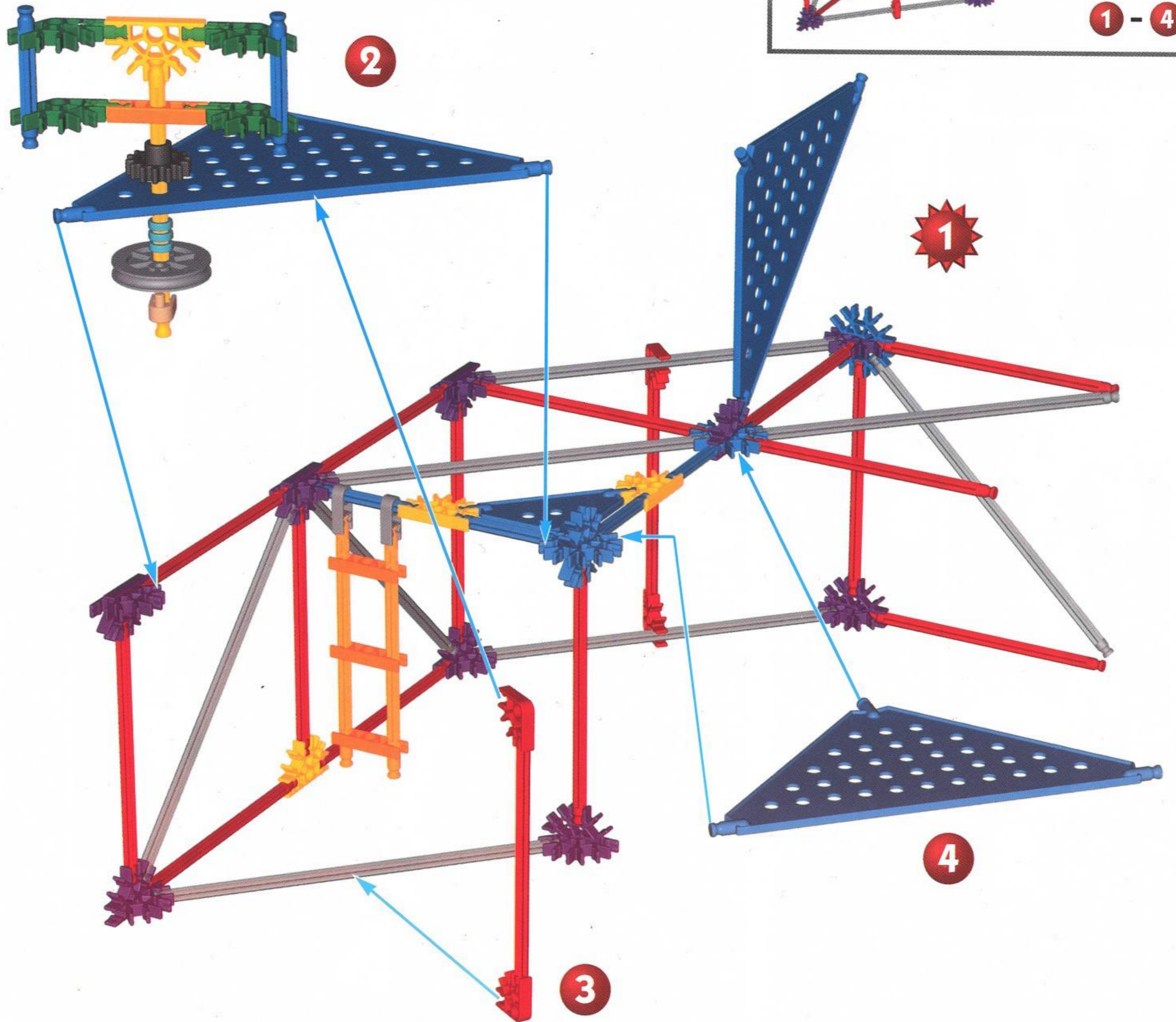
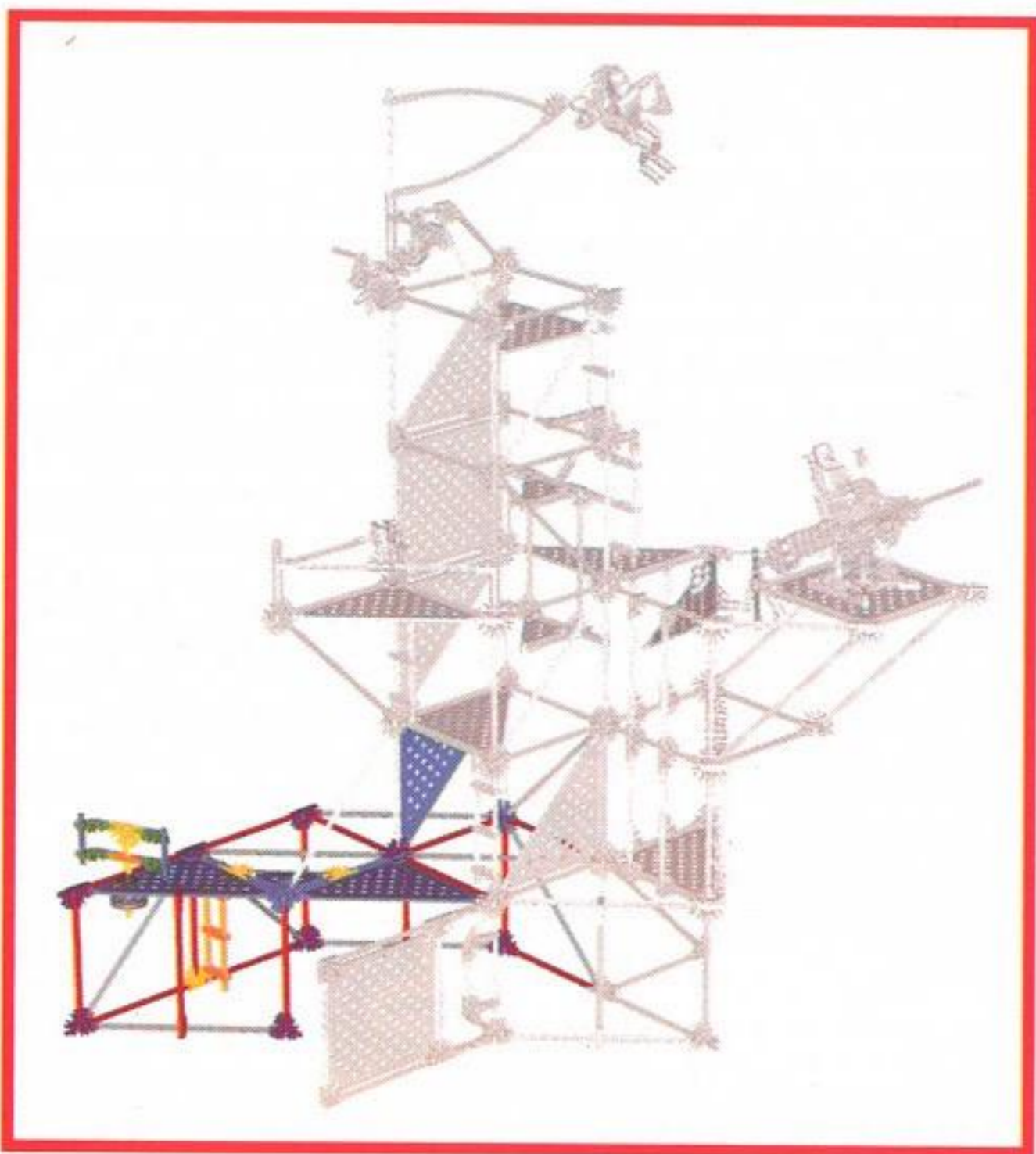

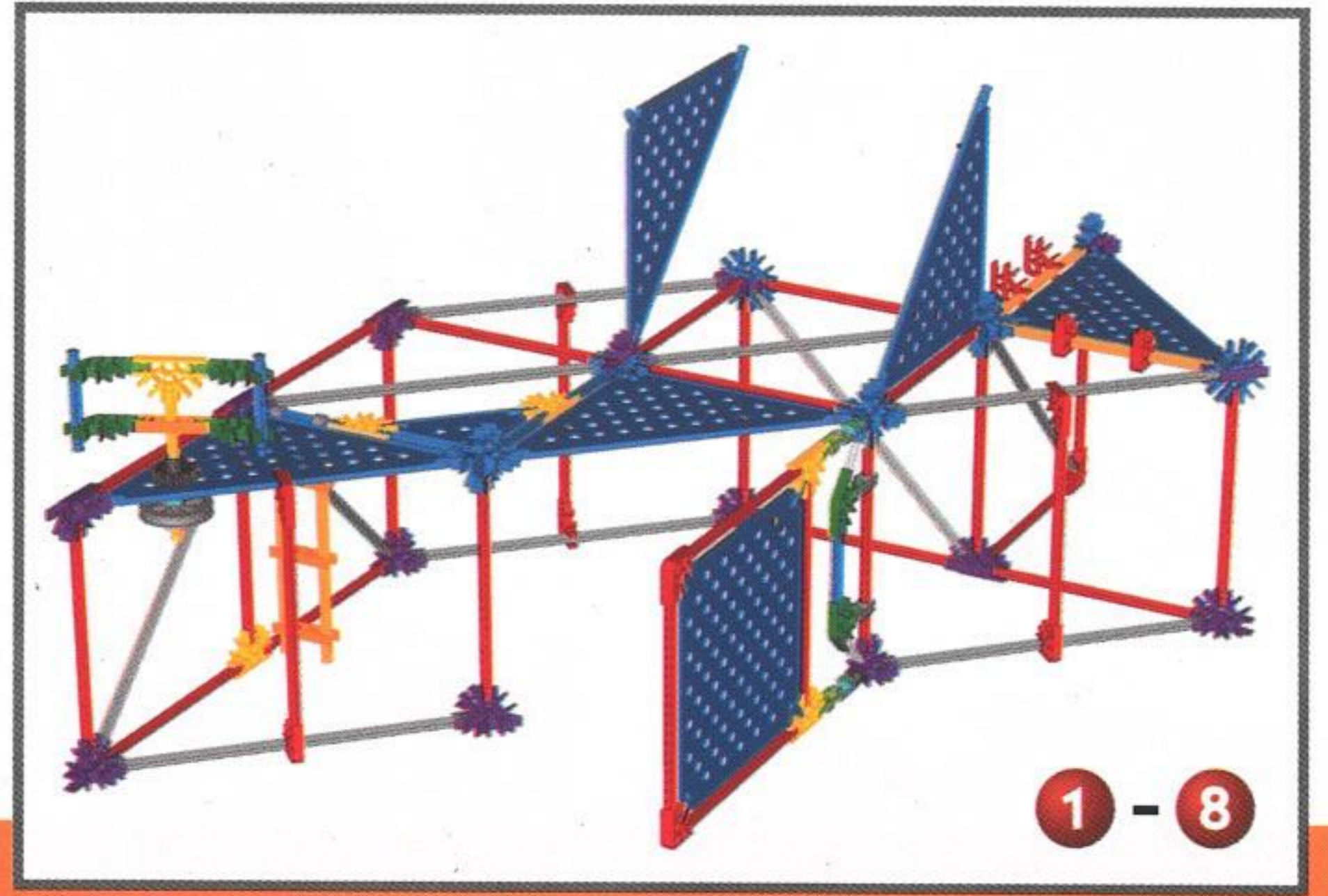
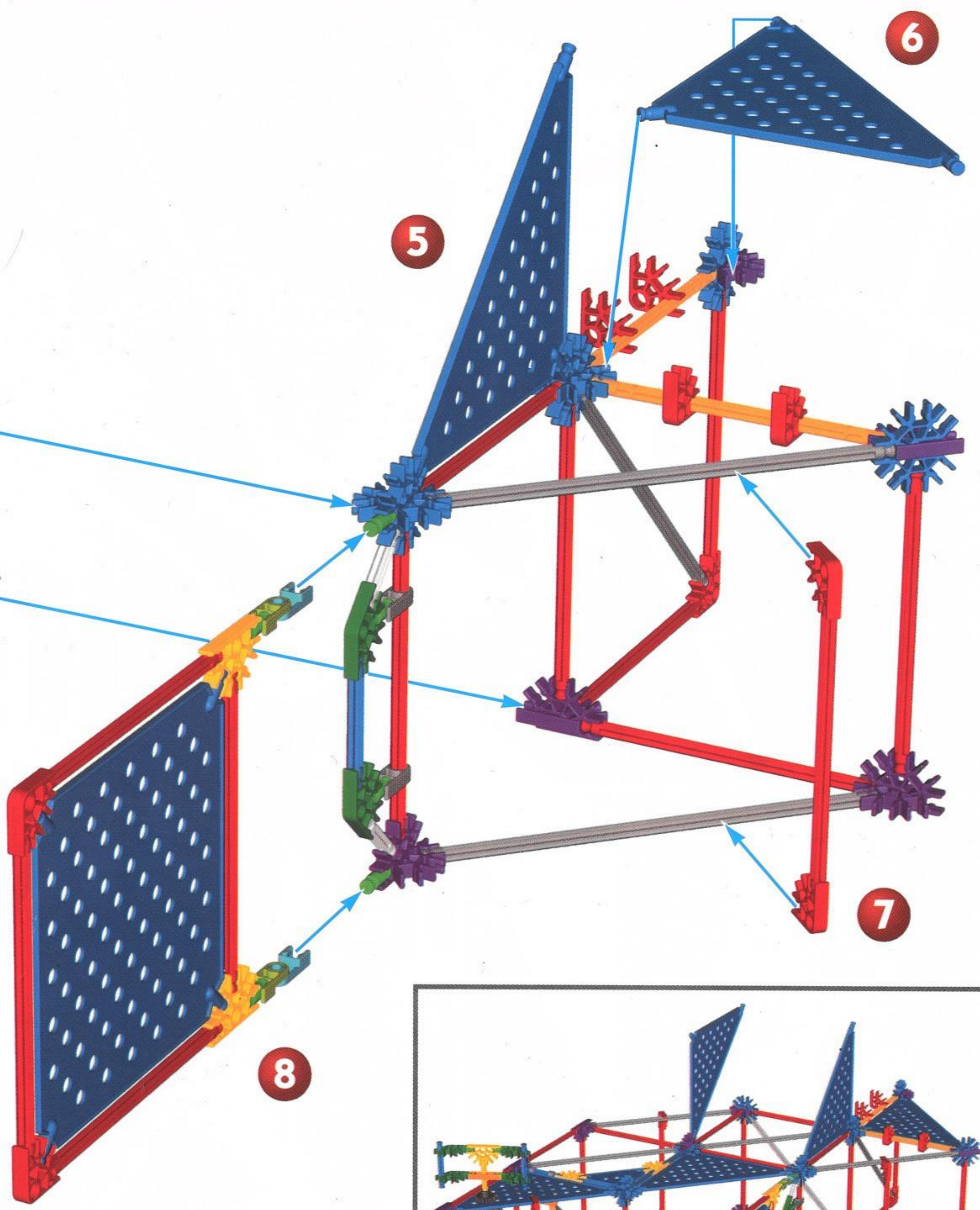
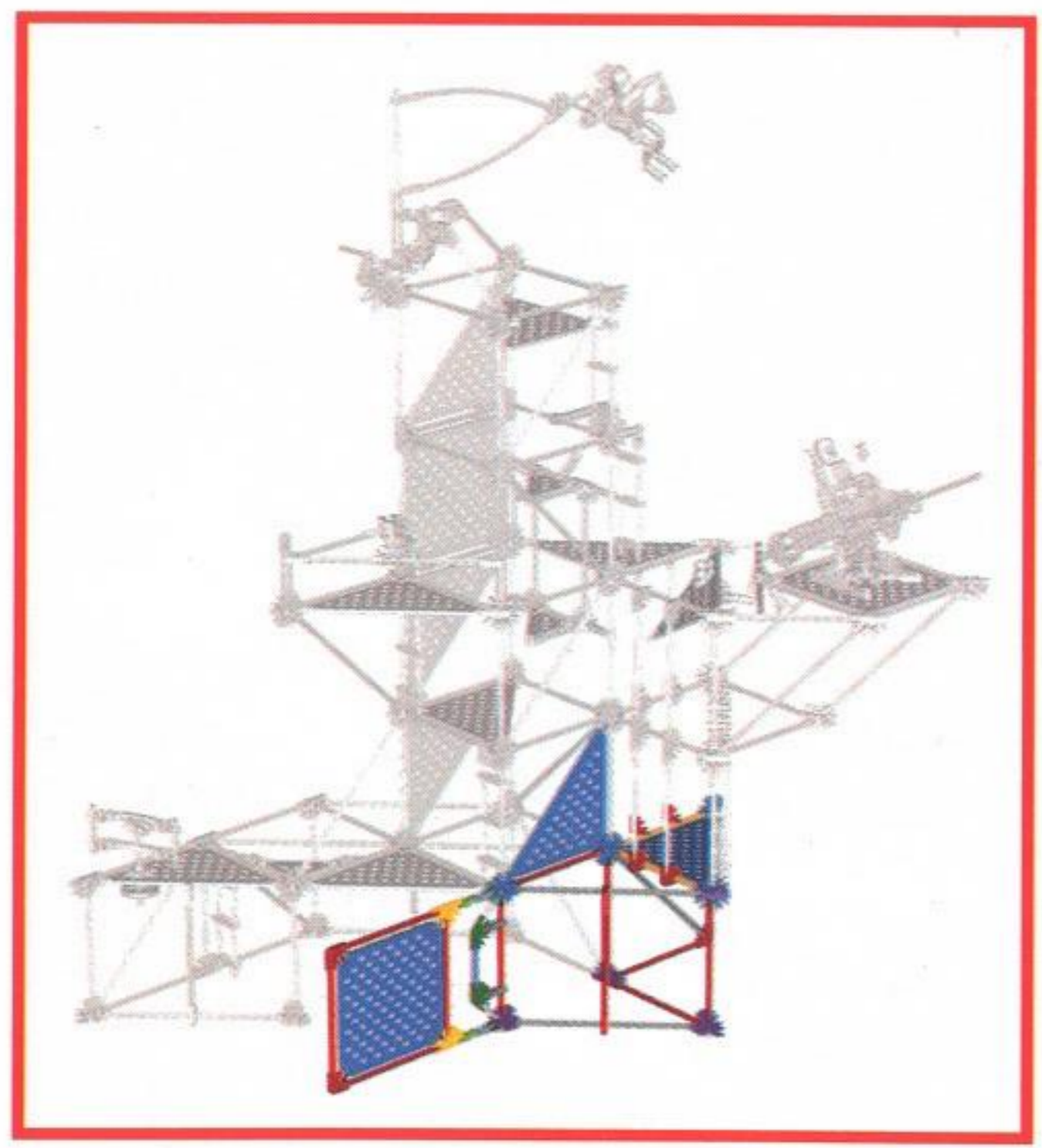
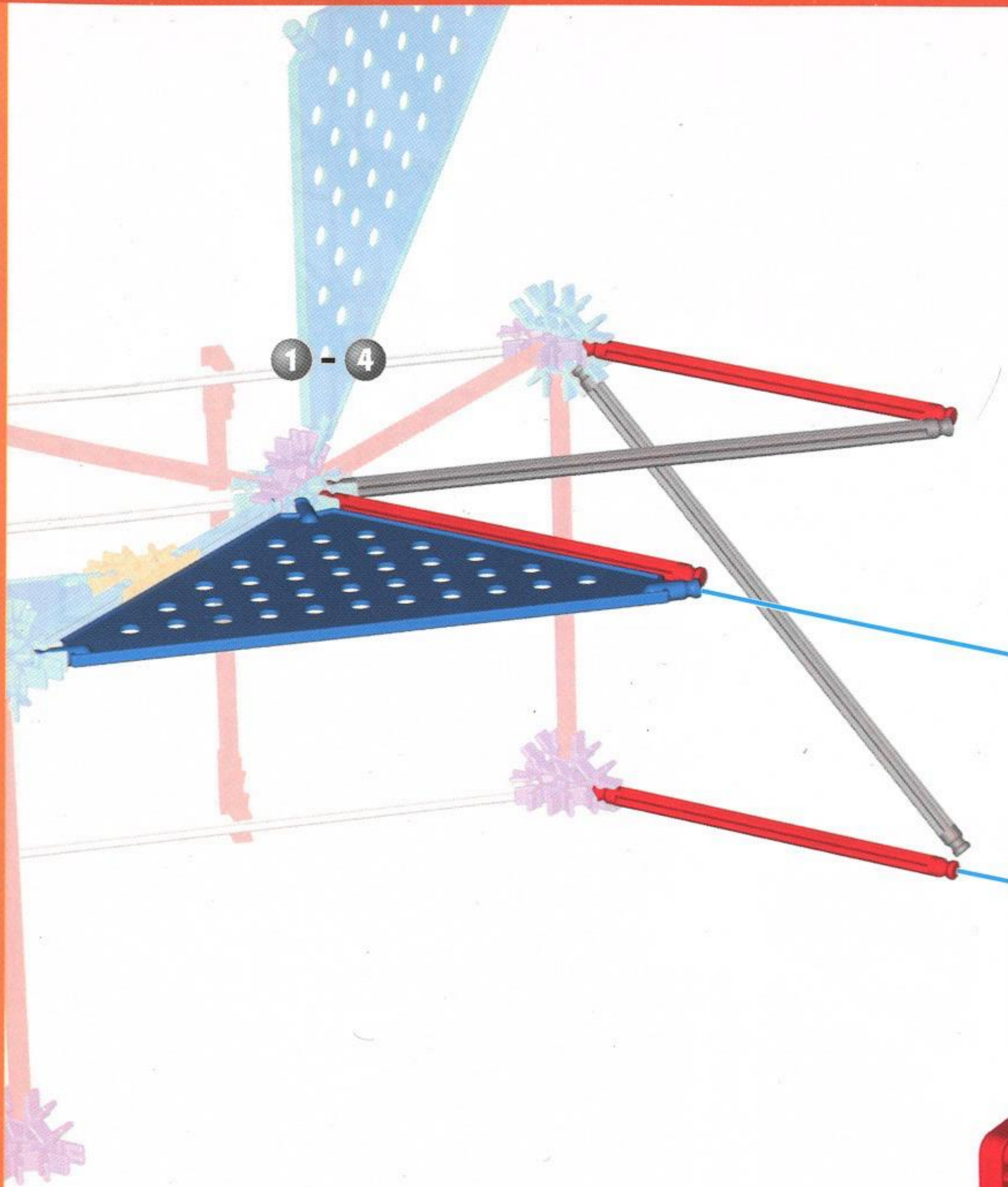

10

10

10

1 - 9

11

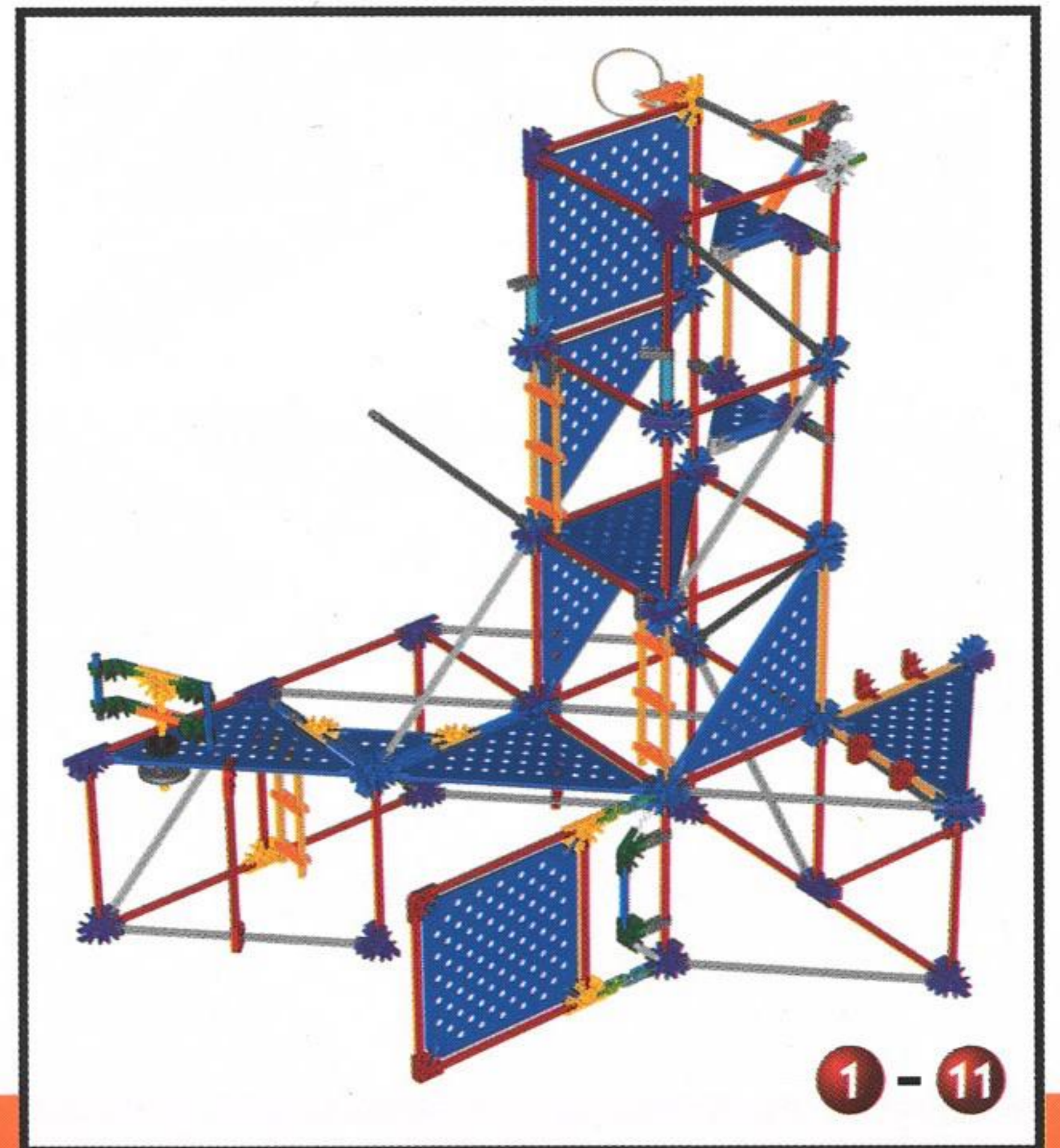
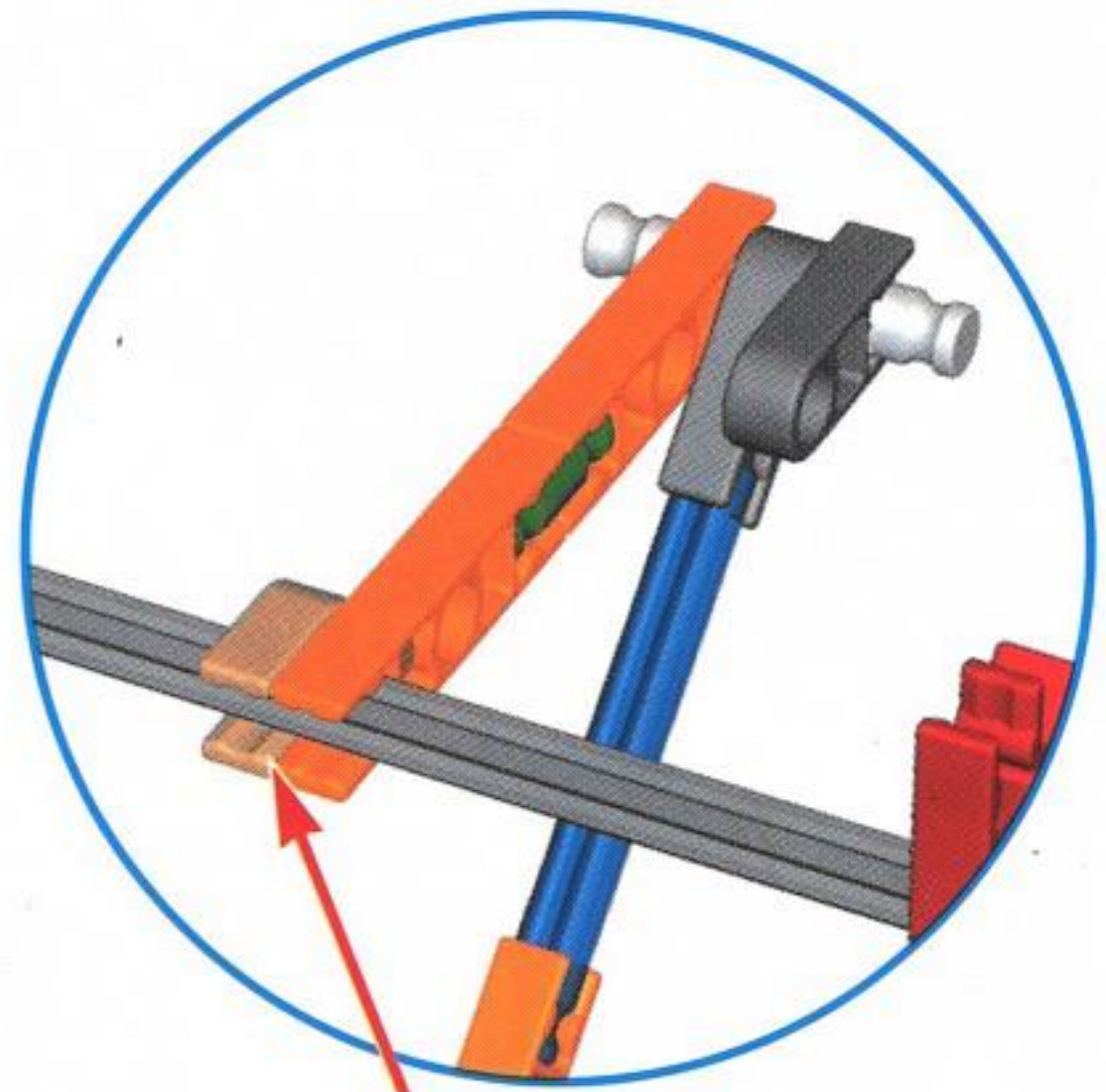

1 - 11

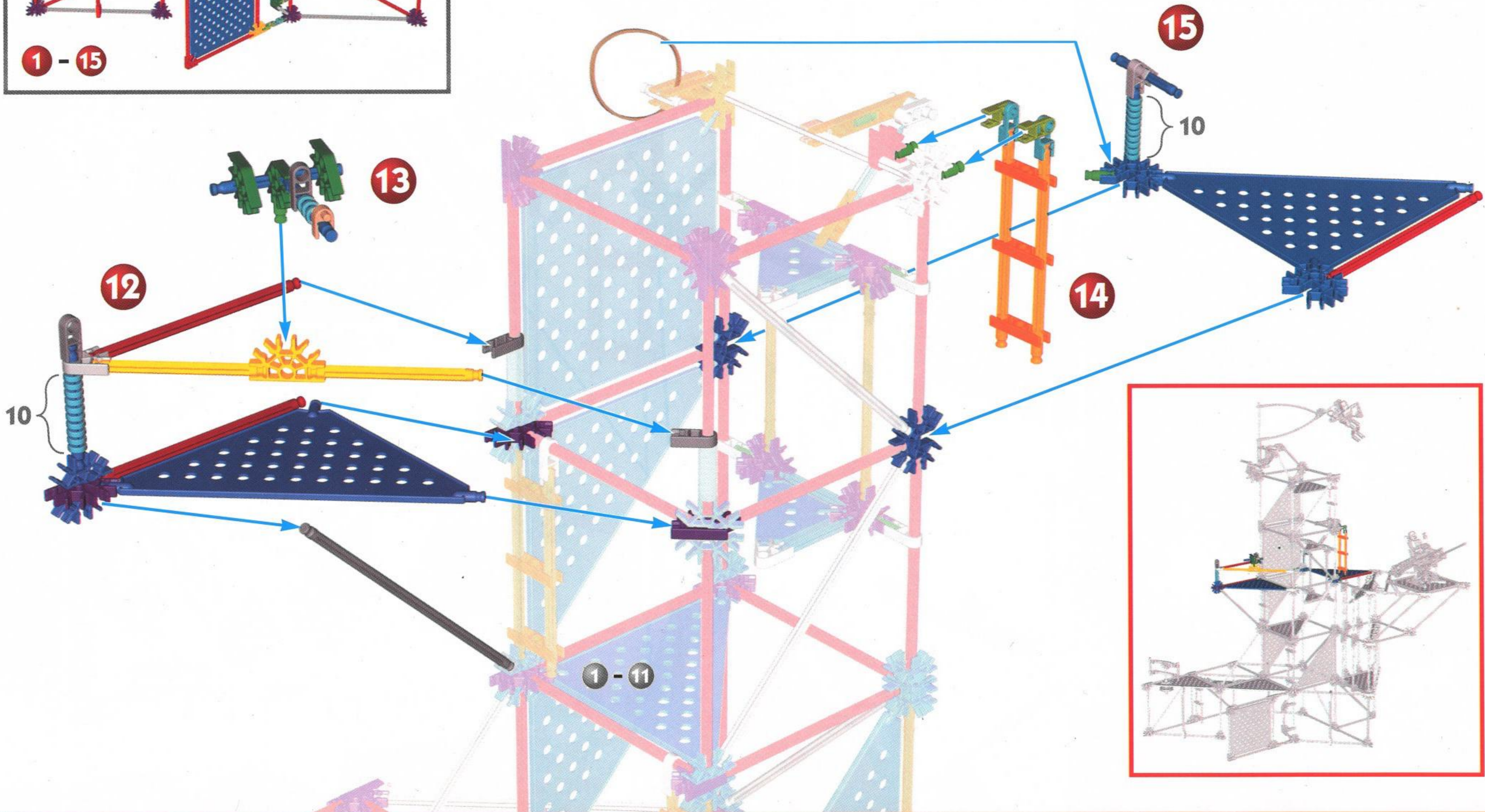
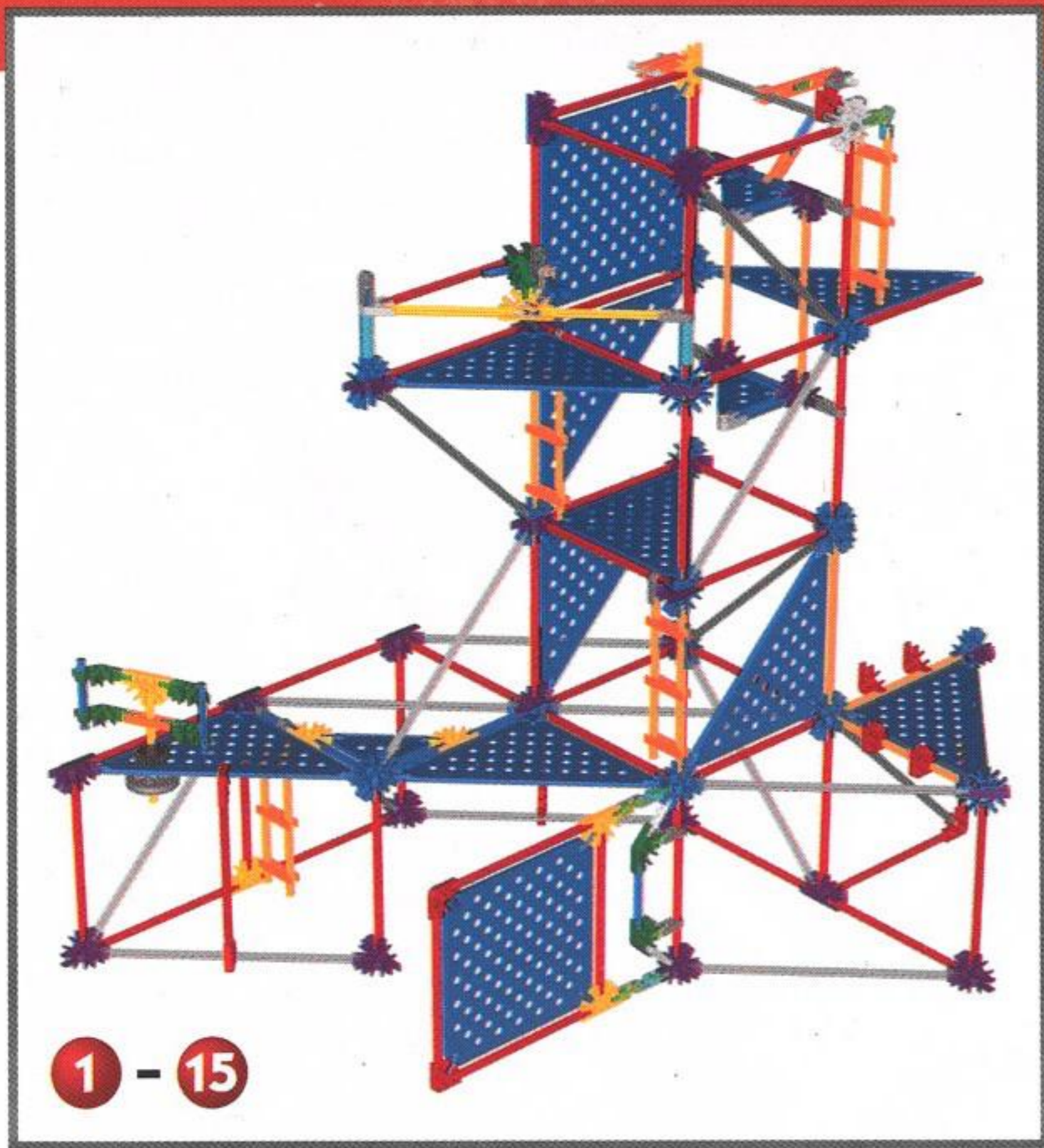

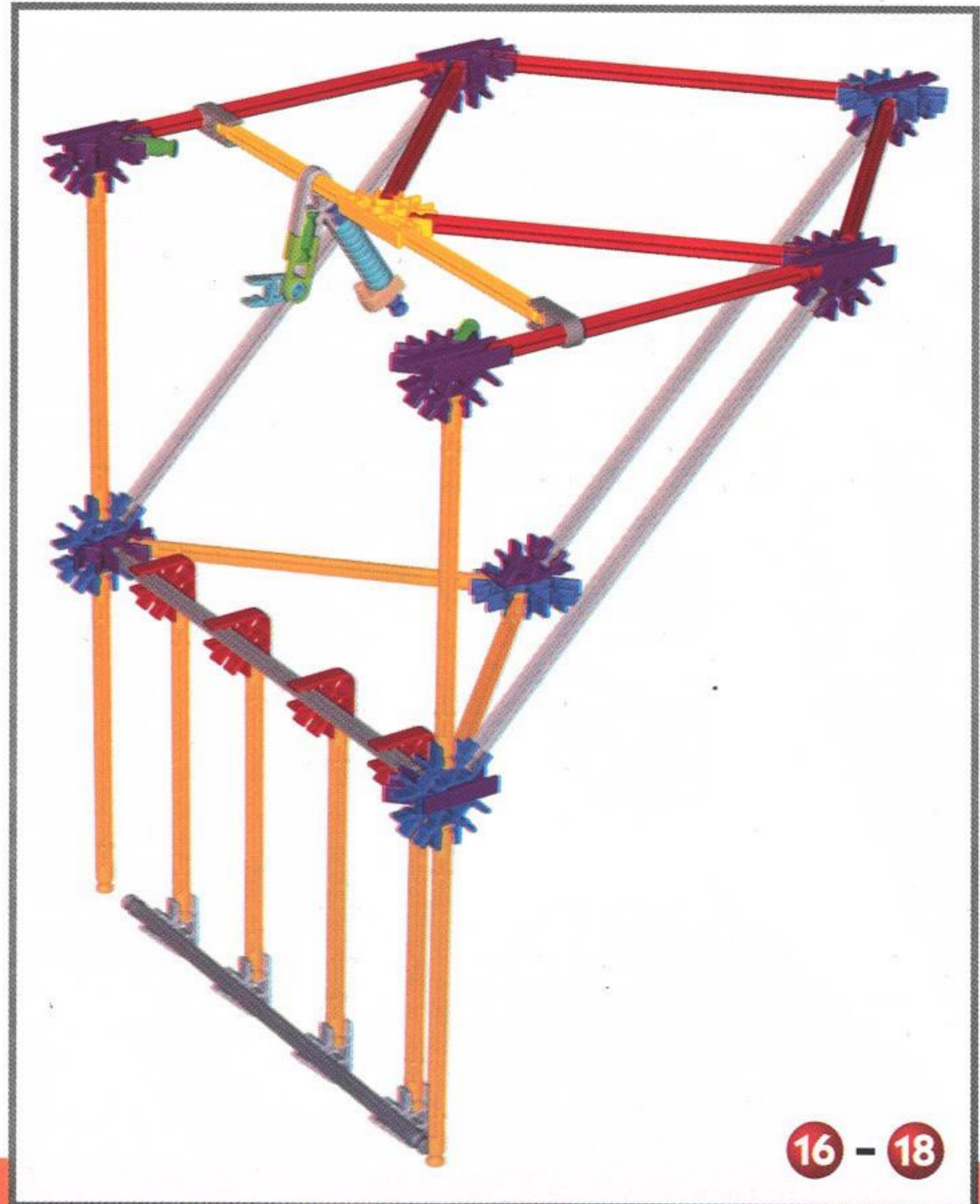
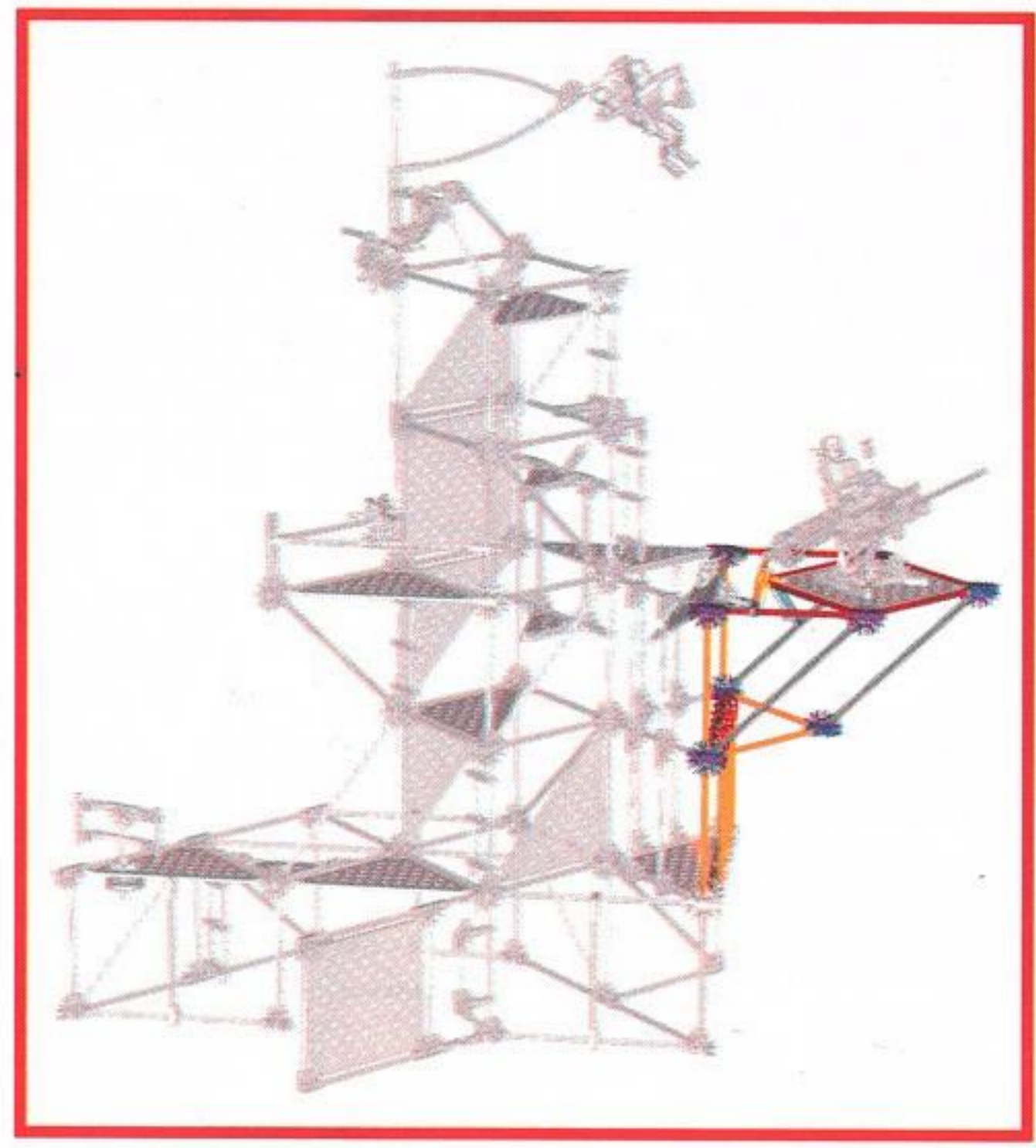
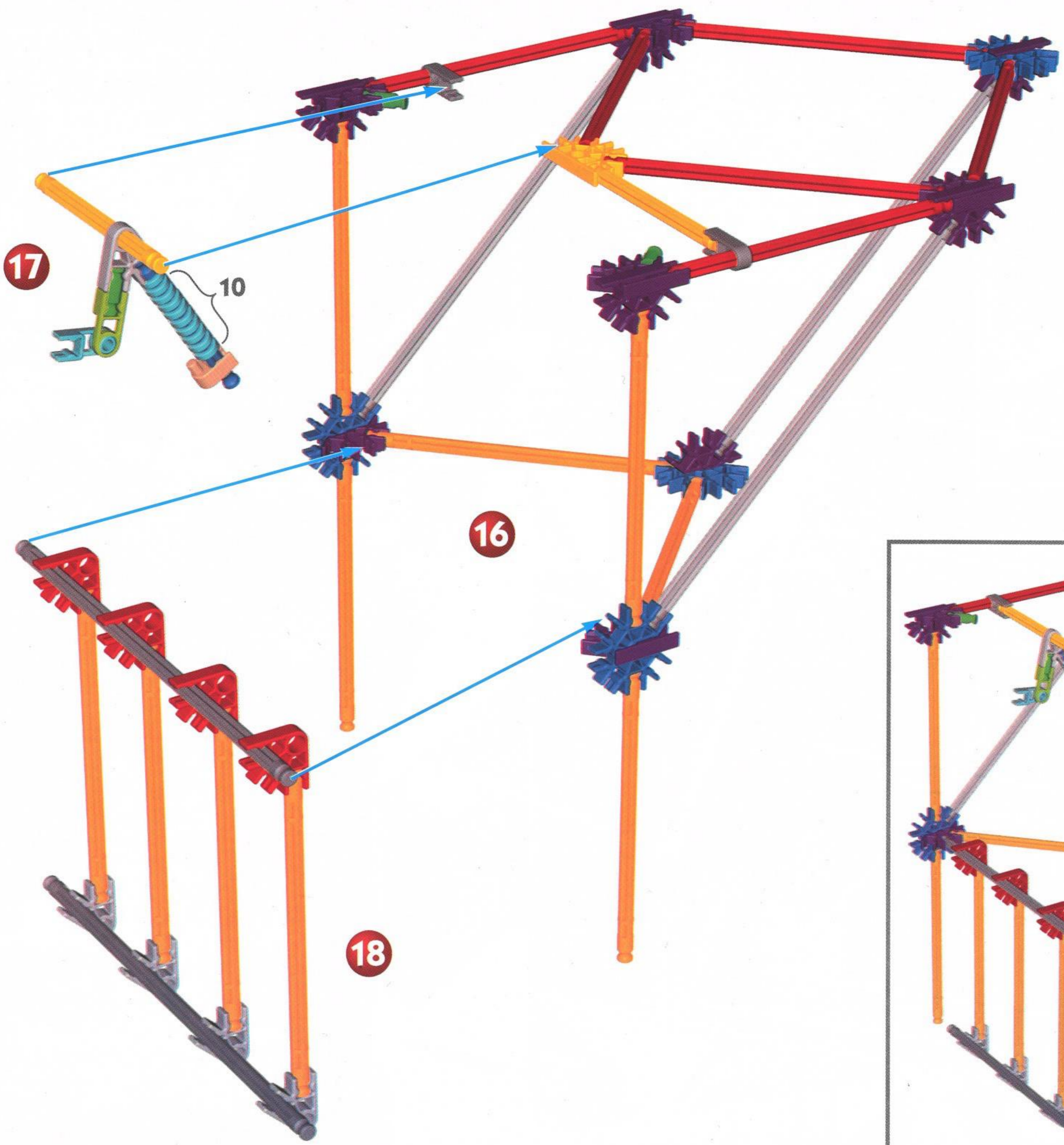

16 - 18

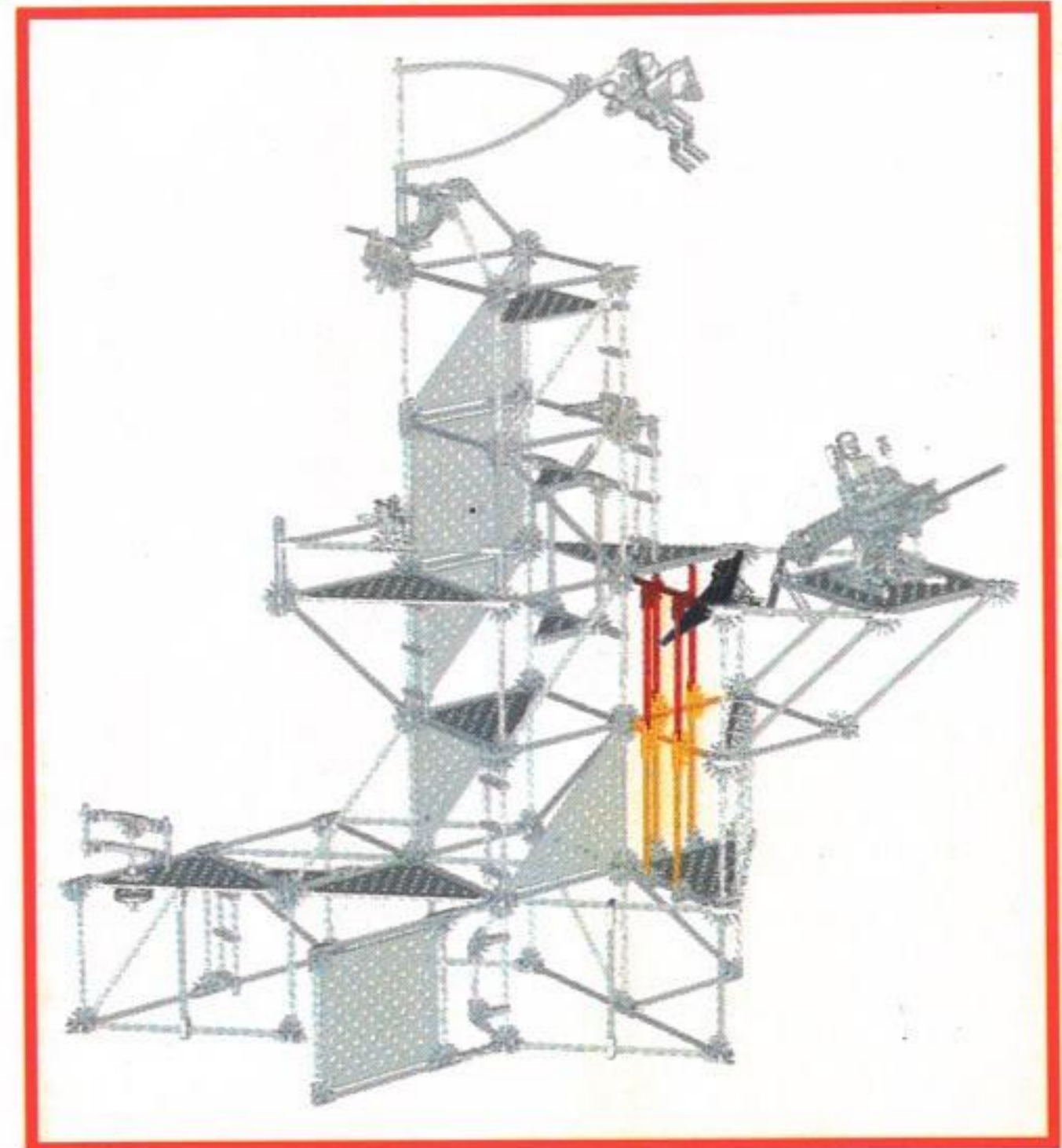
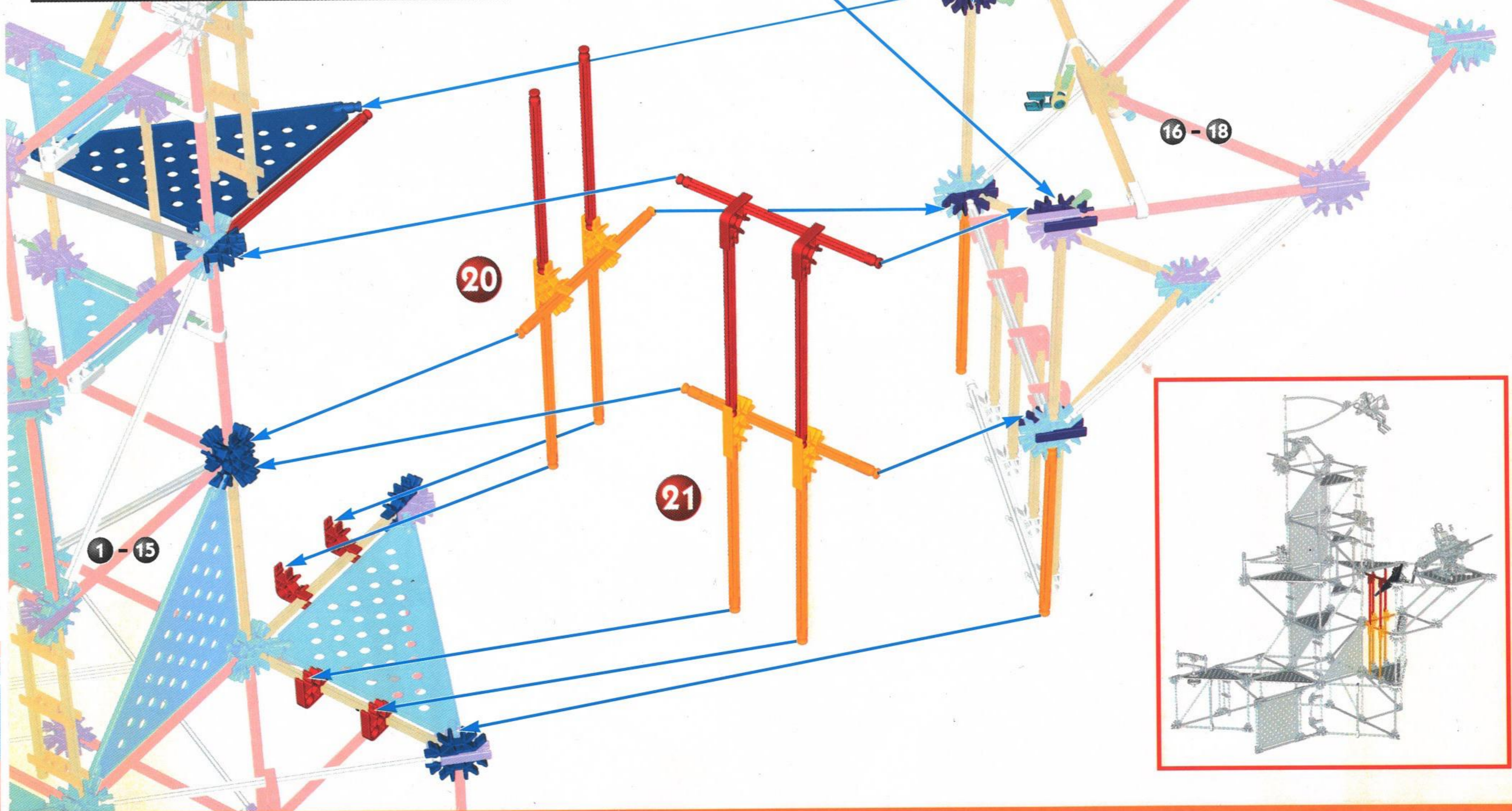
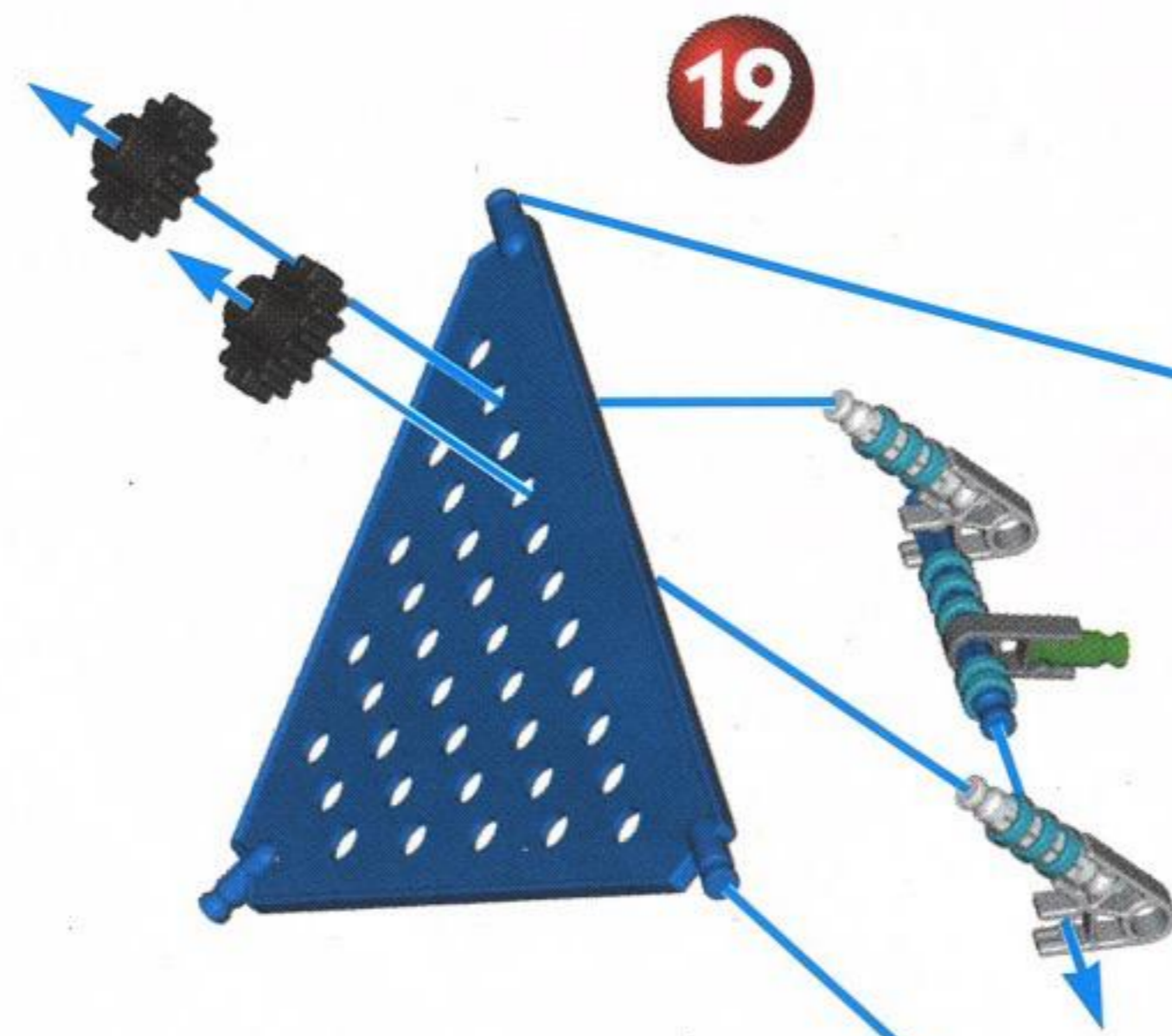
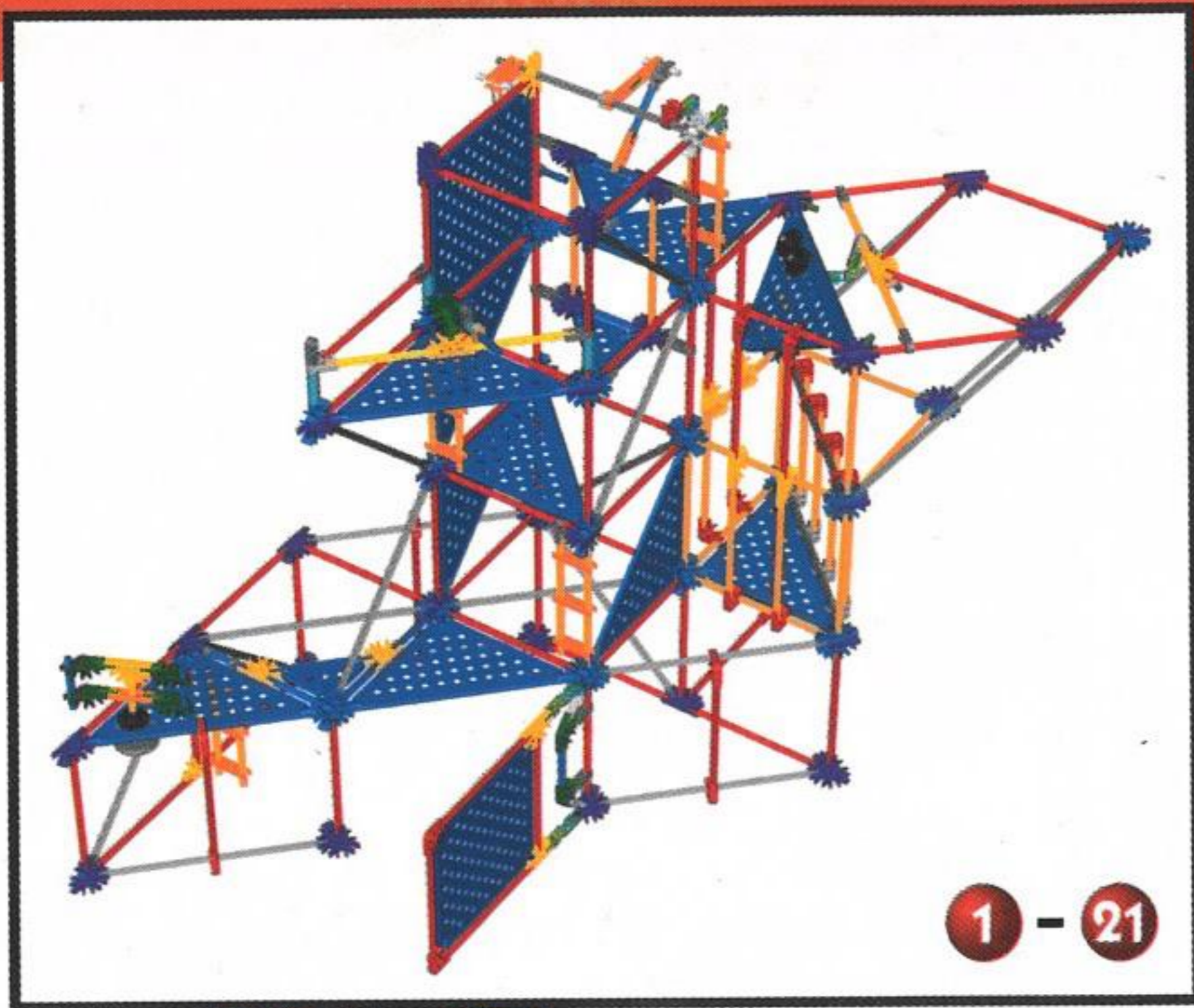

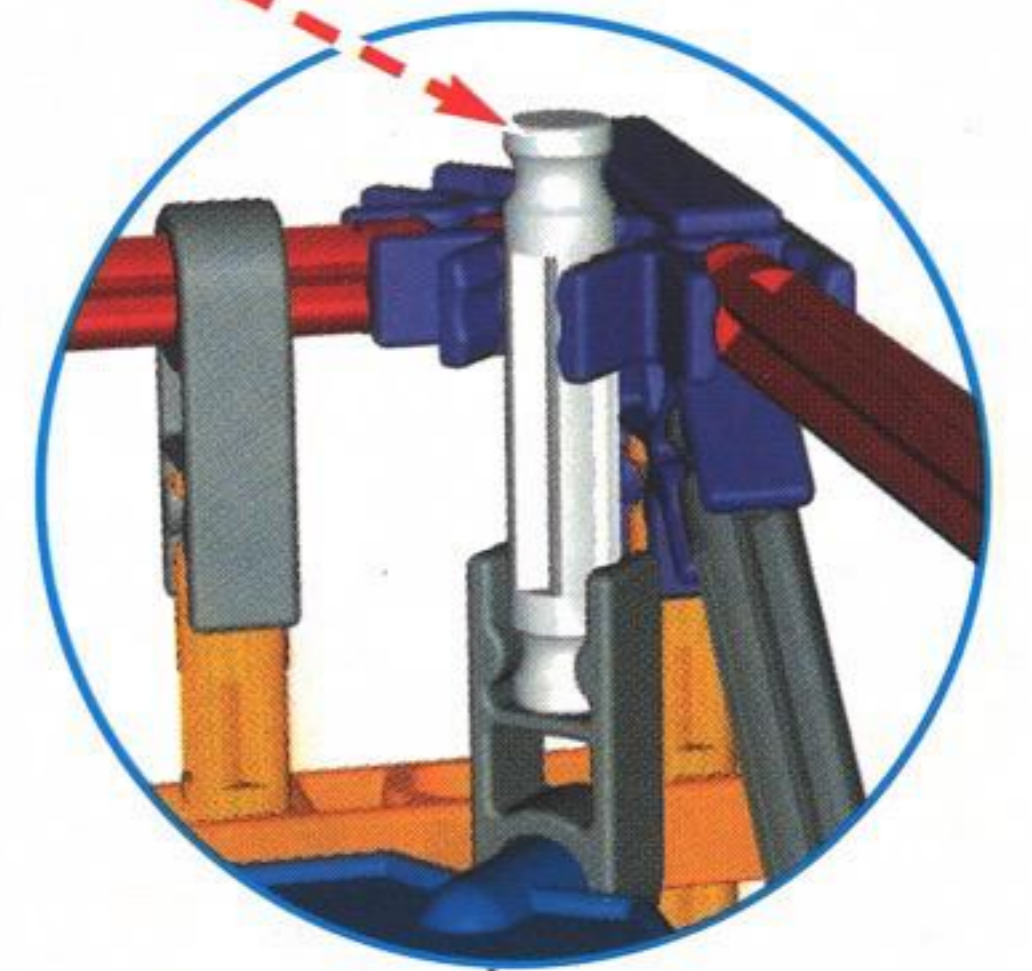
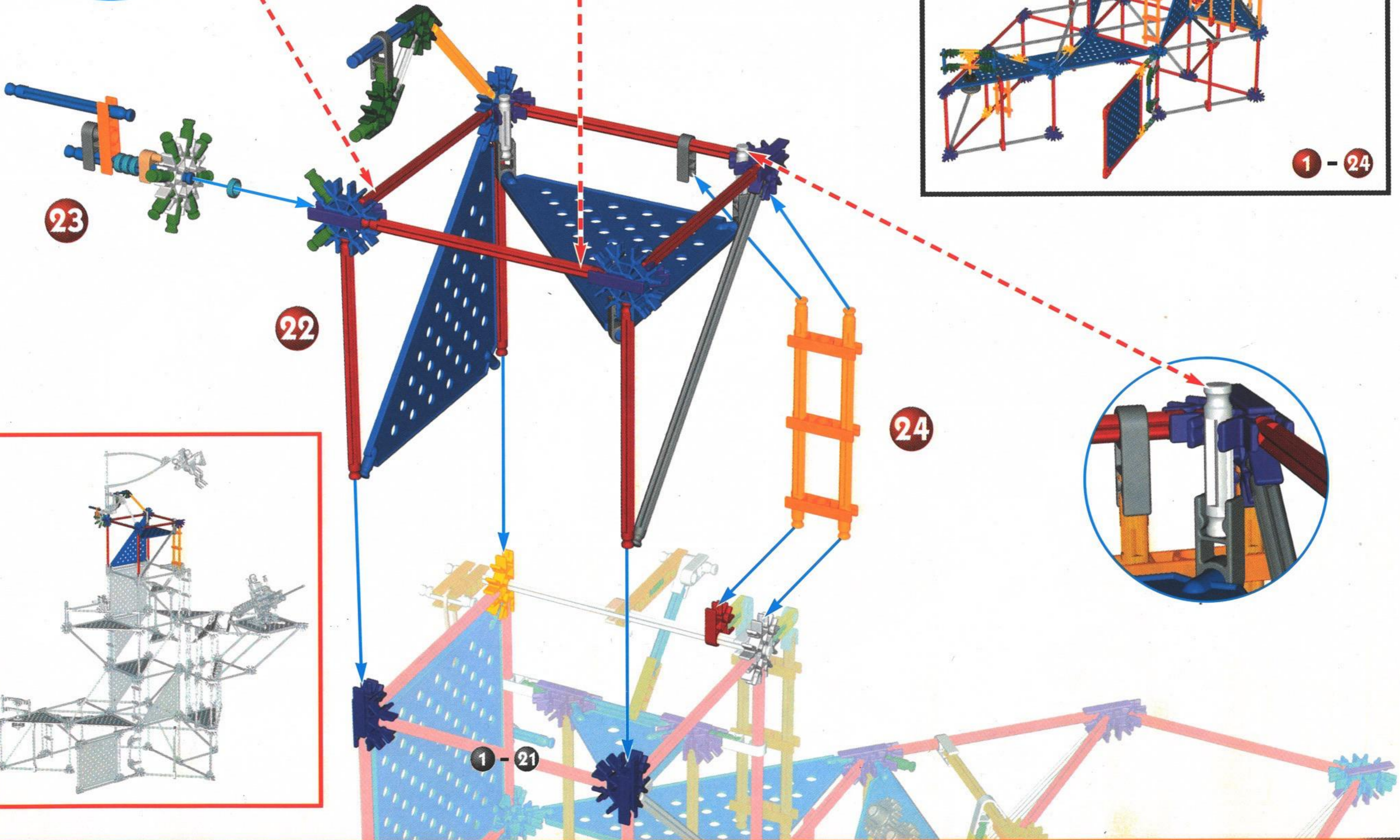
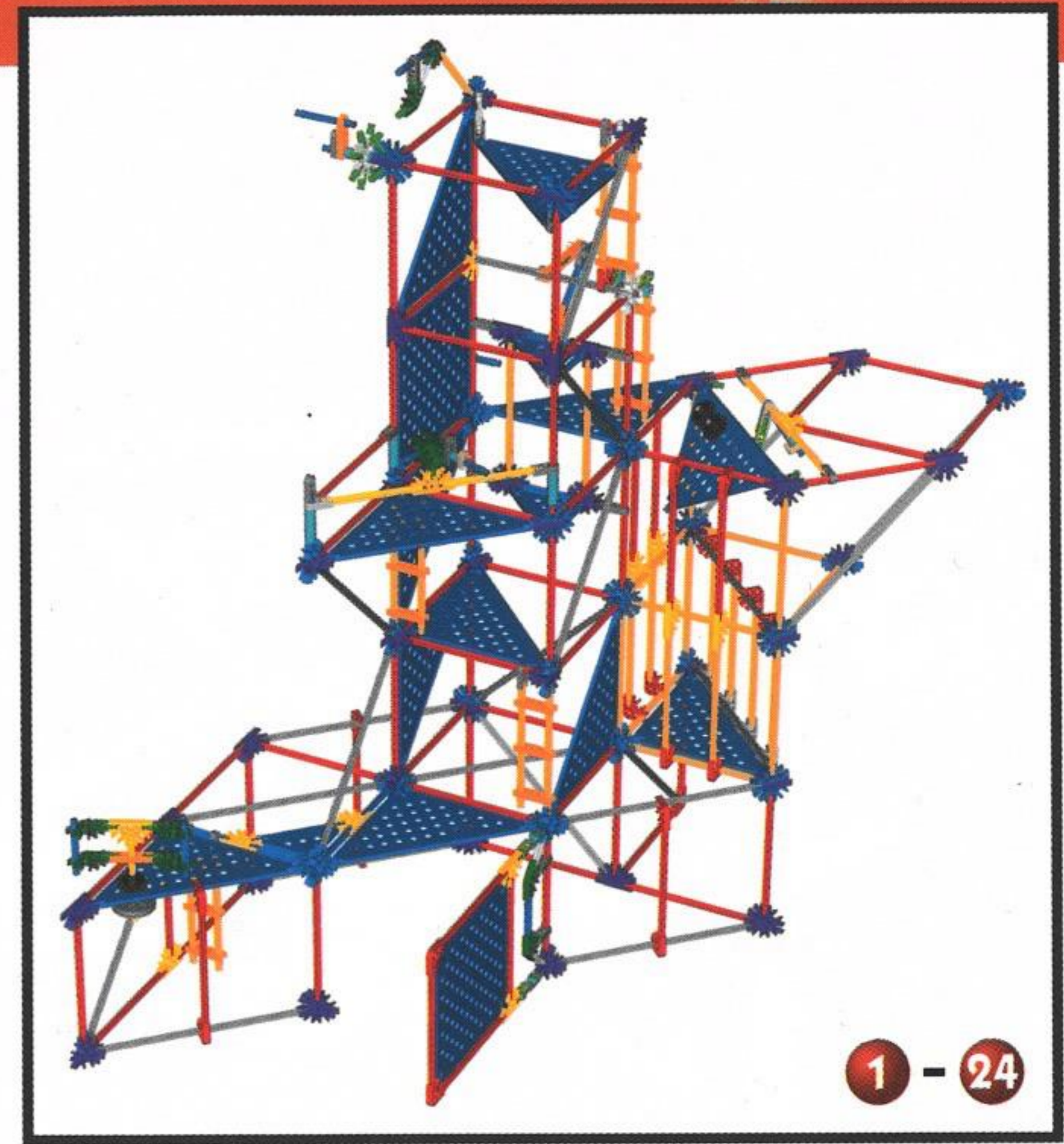
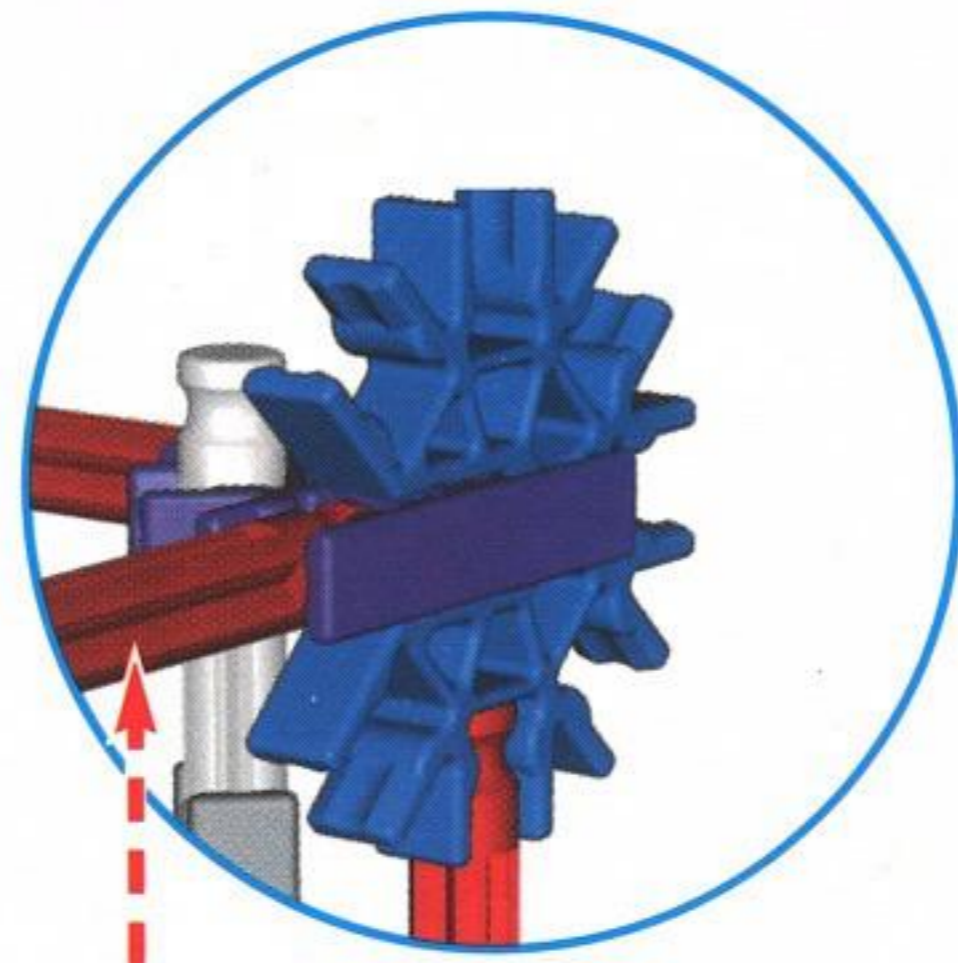
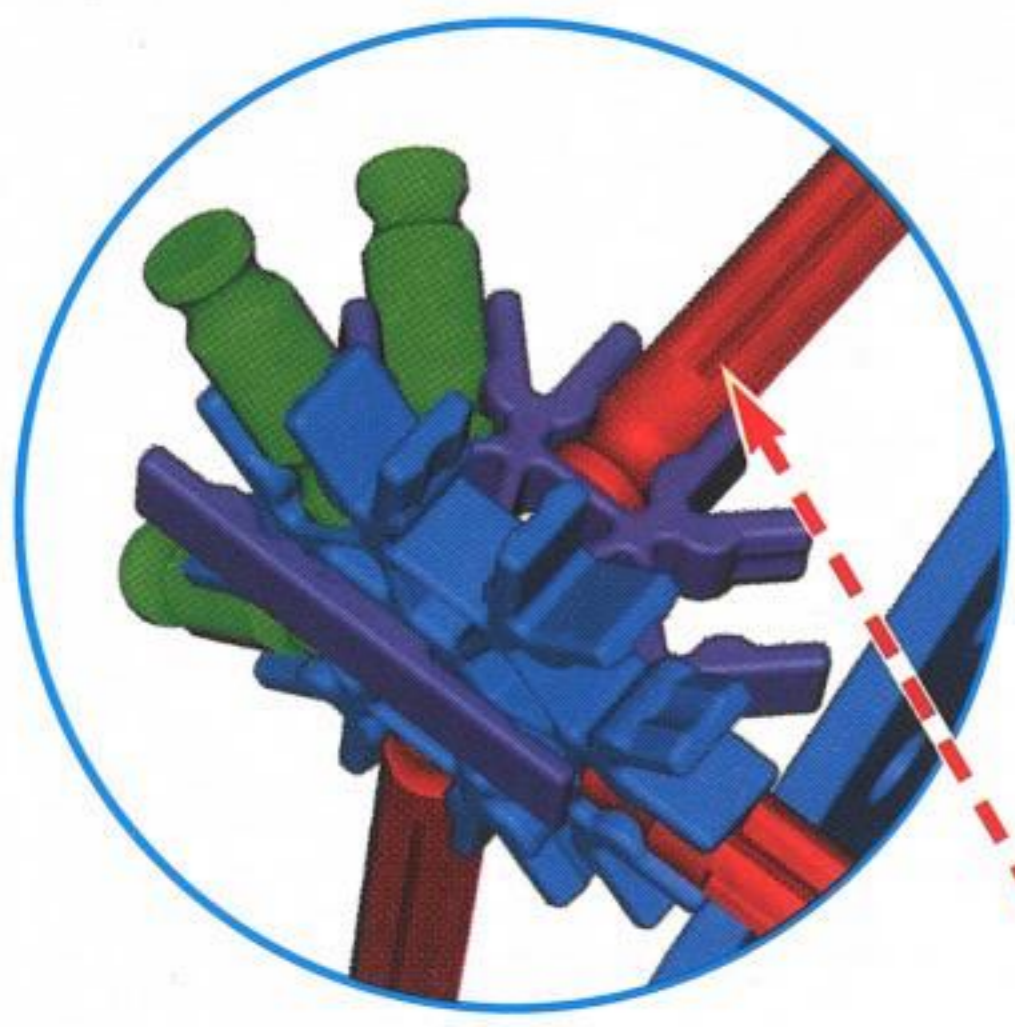

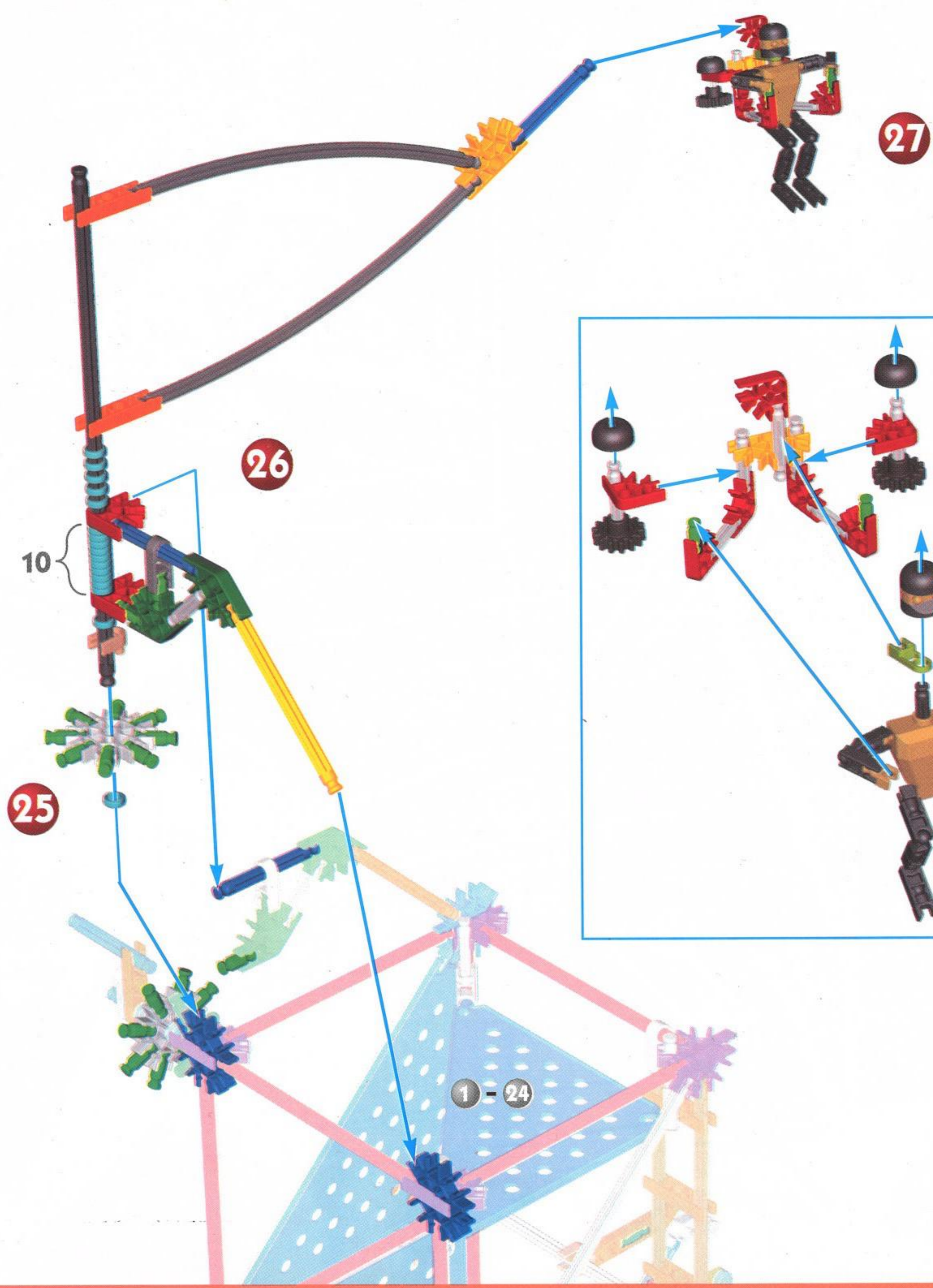

27

26

10

25

1 - 24

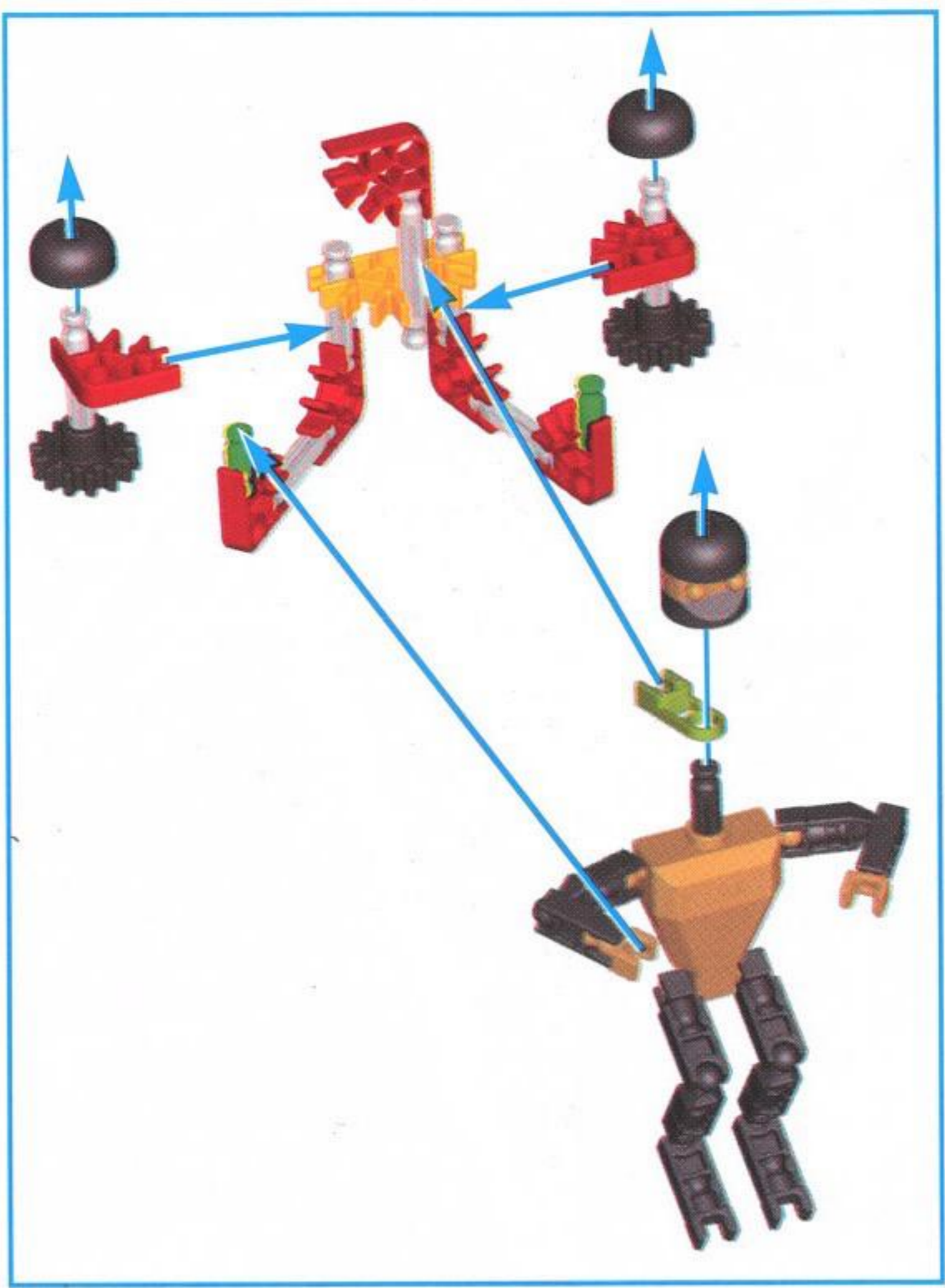

1 - 27

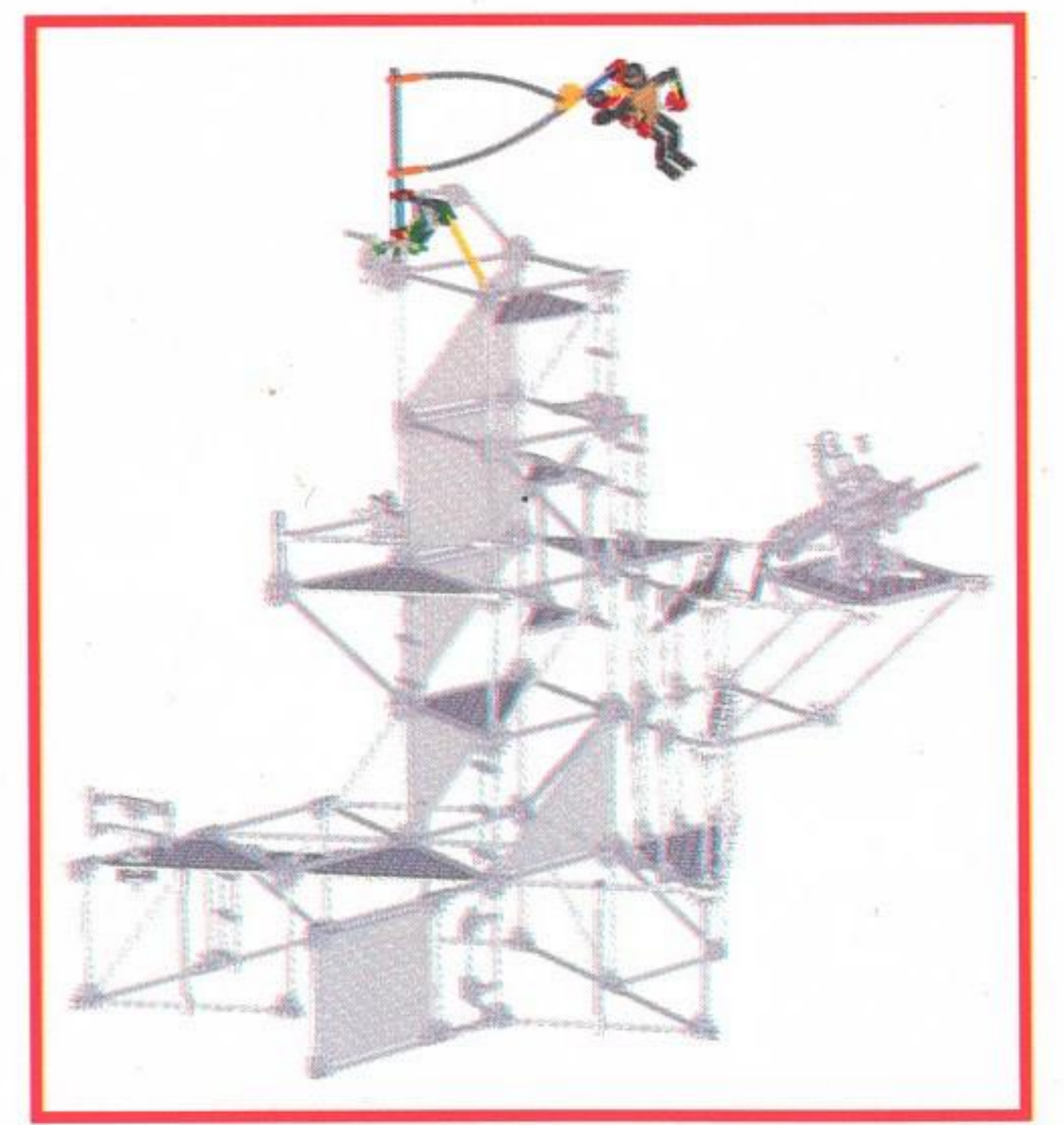

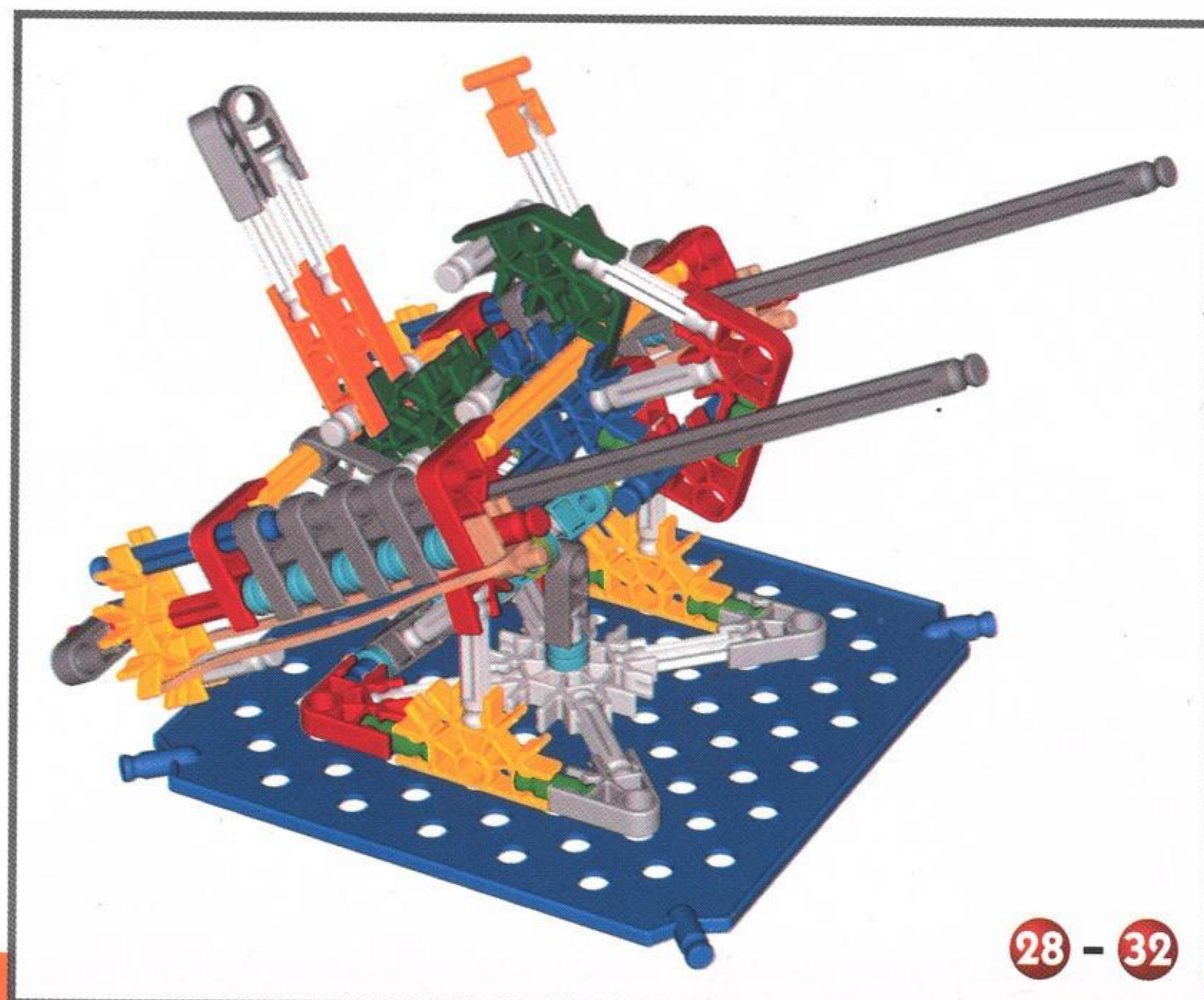
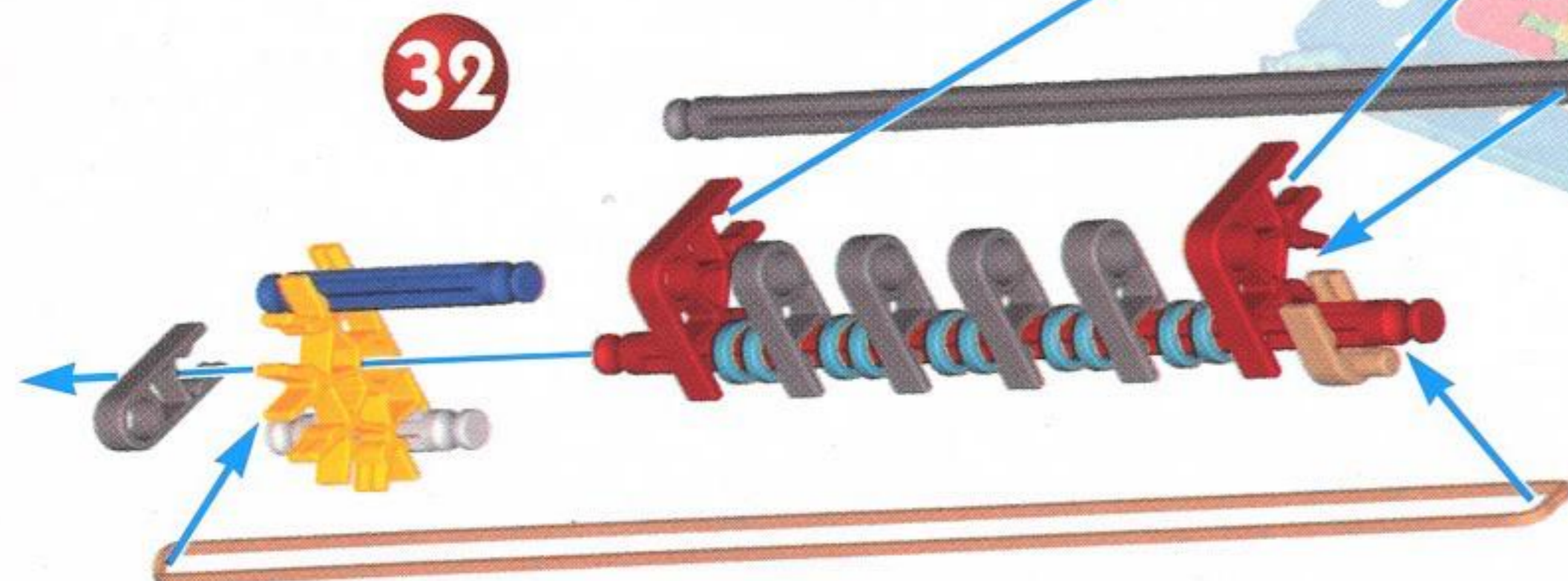
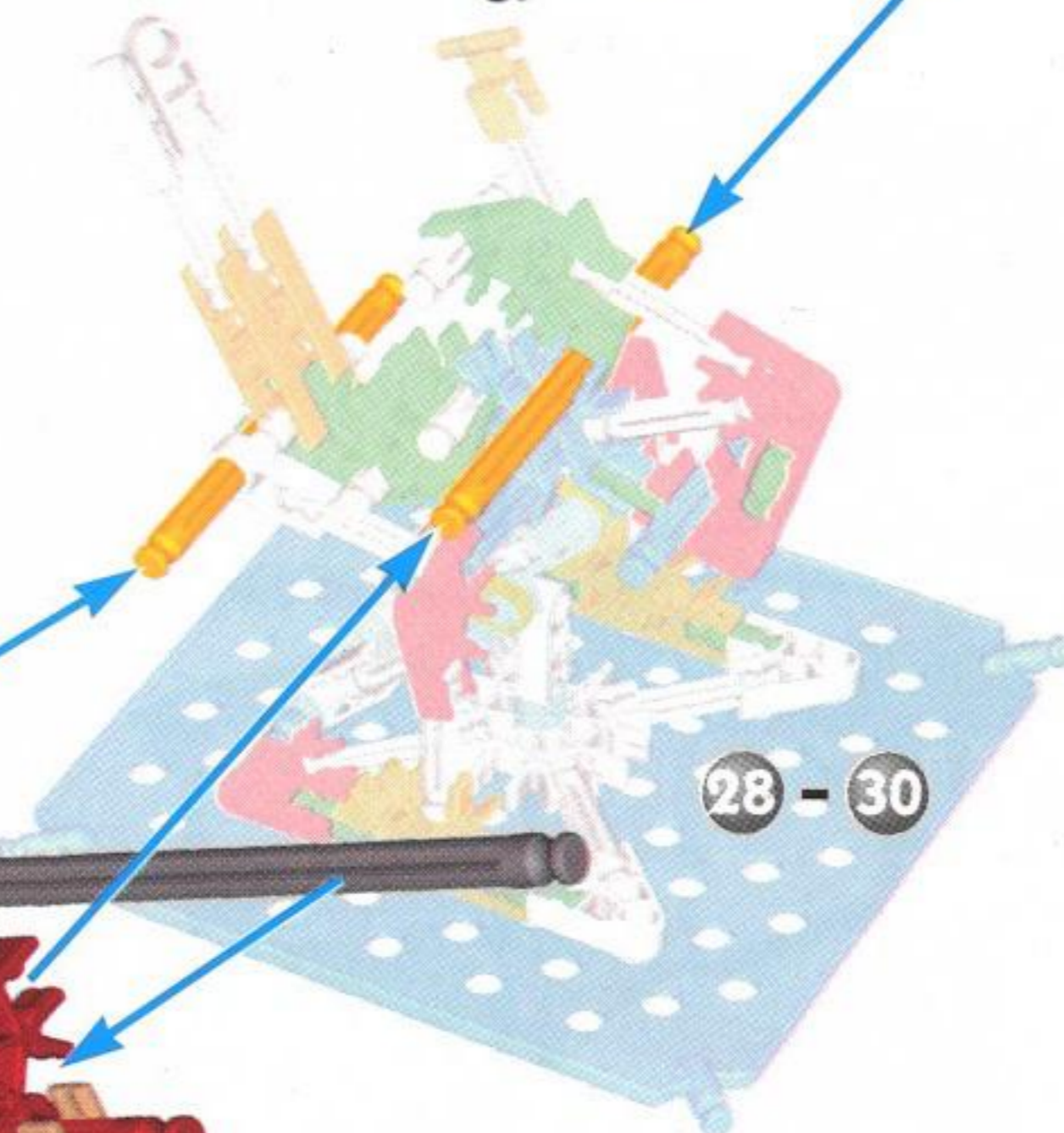
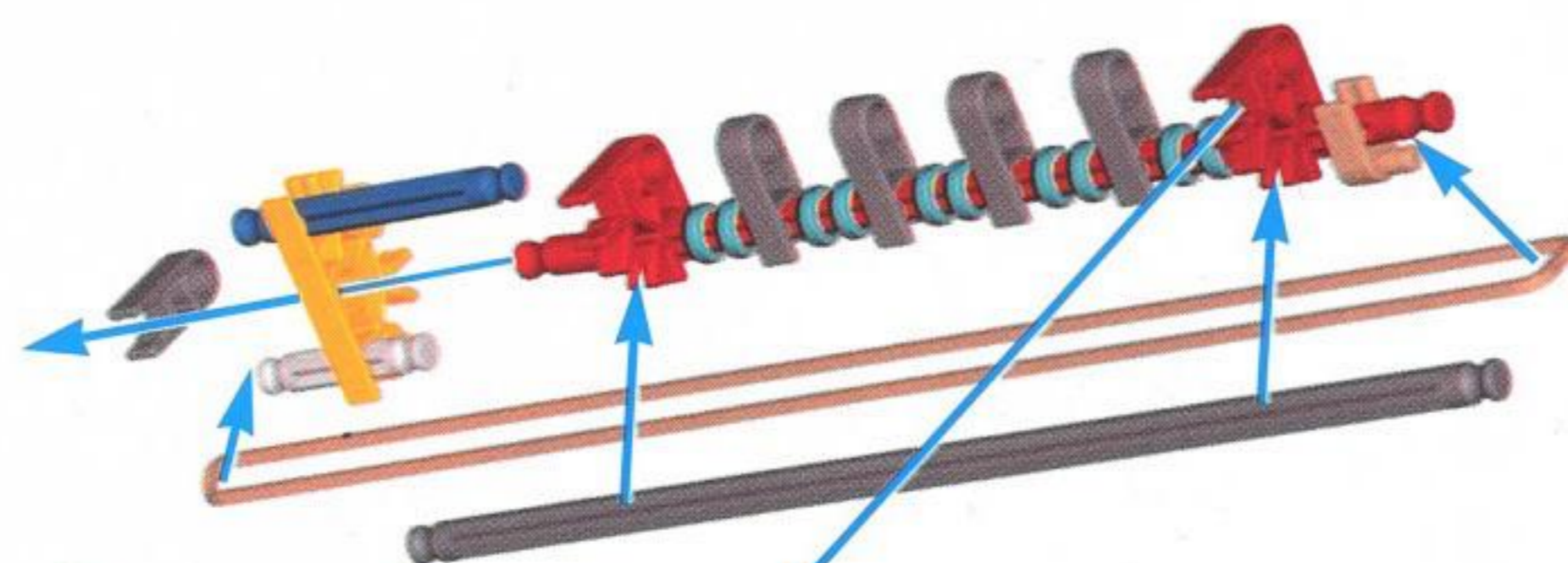
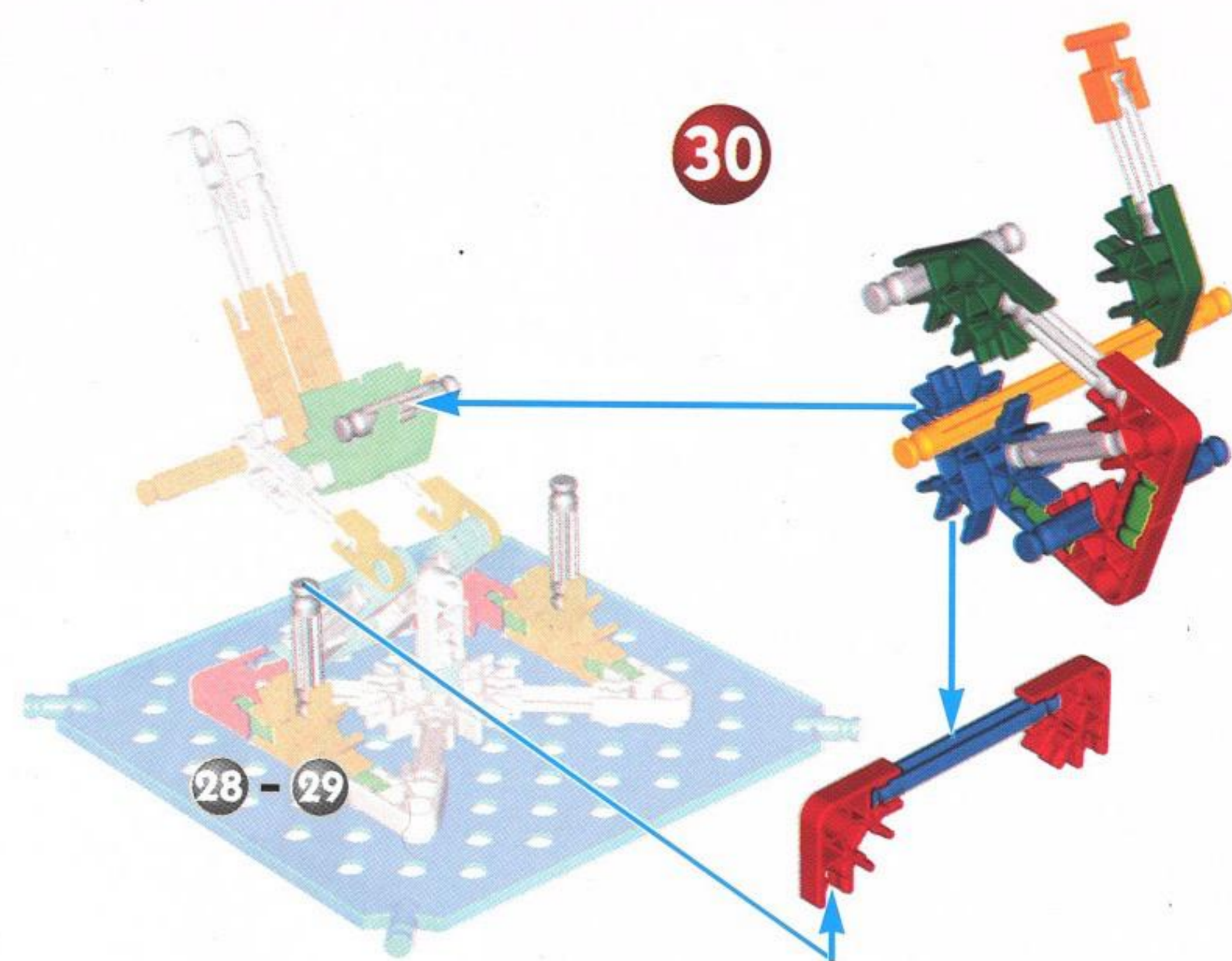
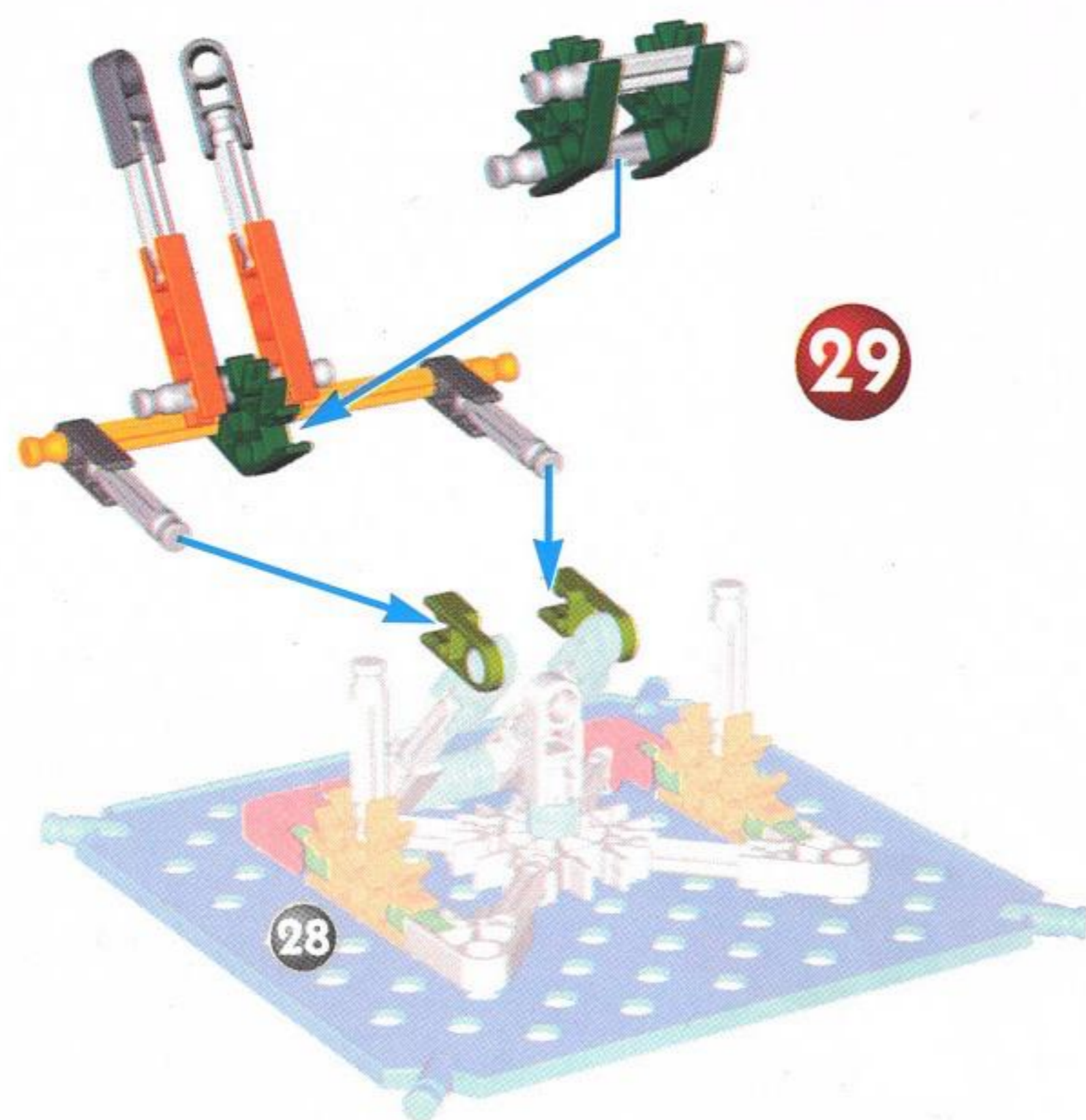

28 - 32

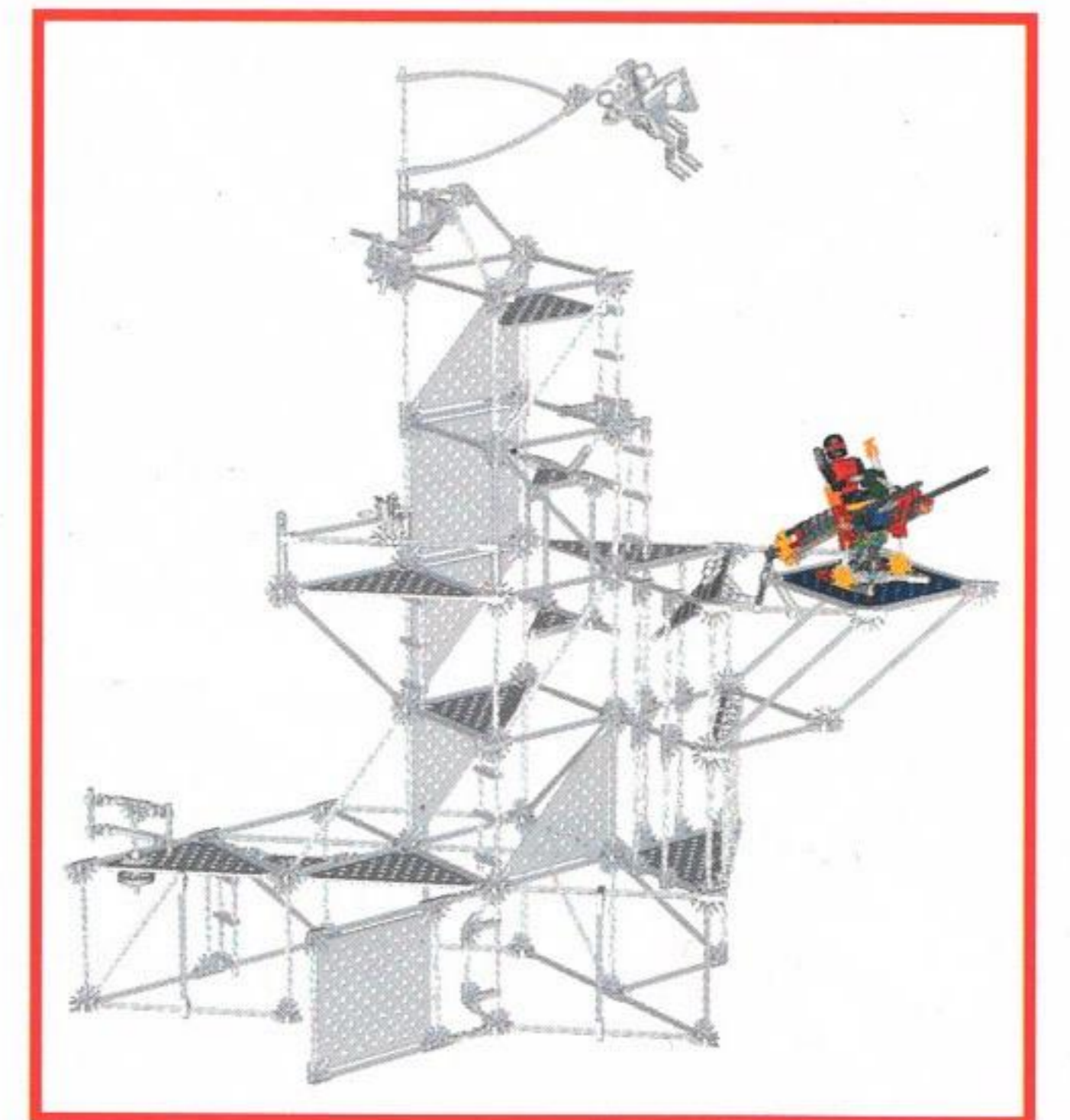
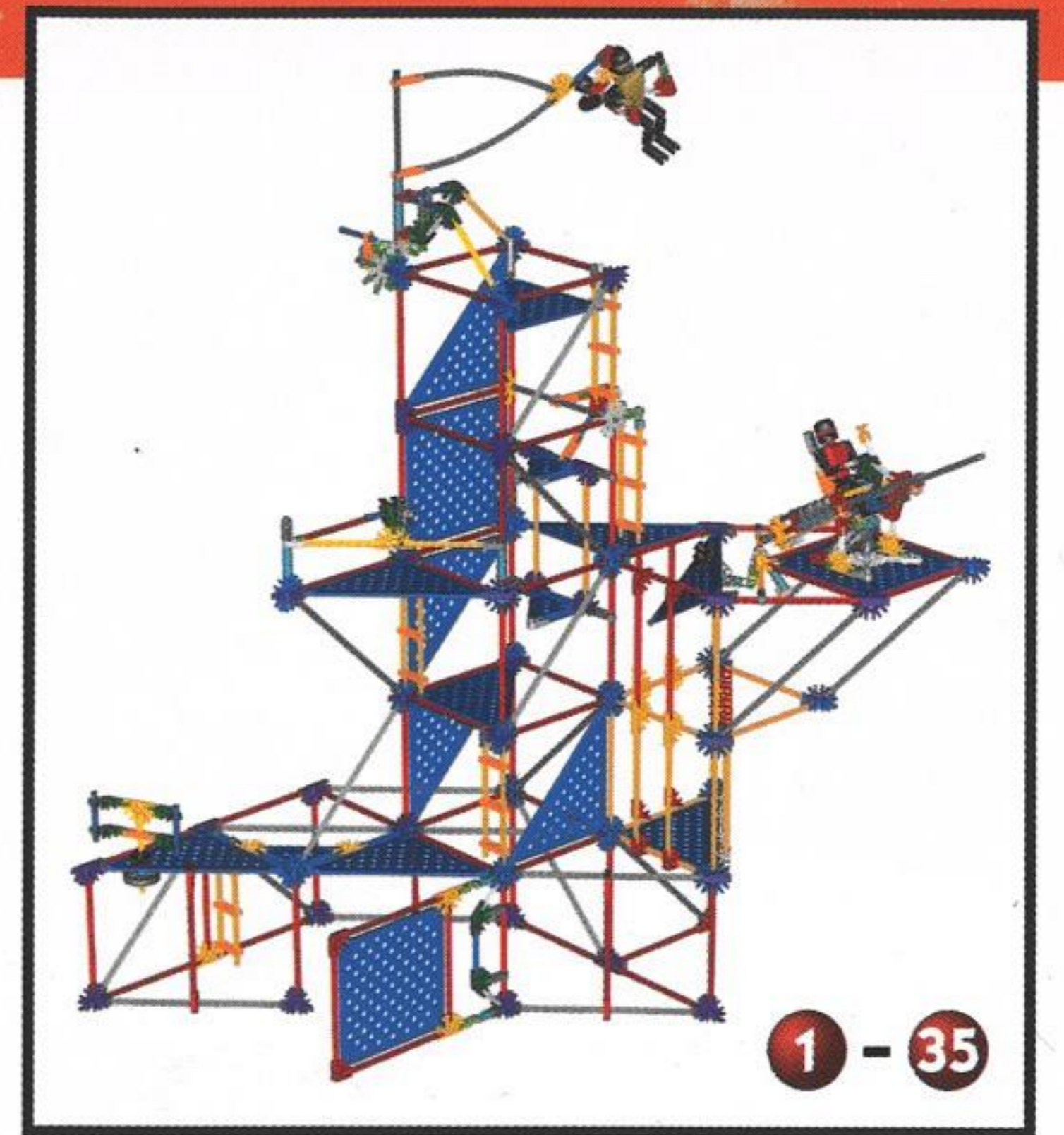
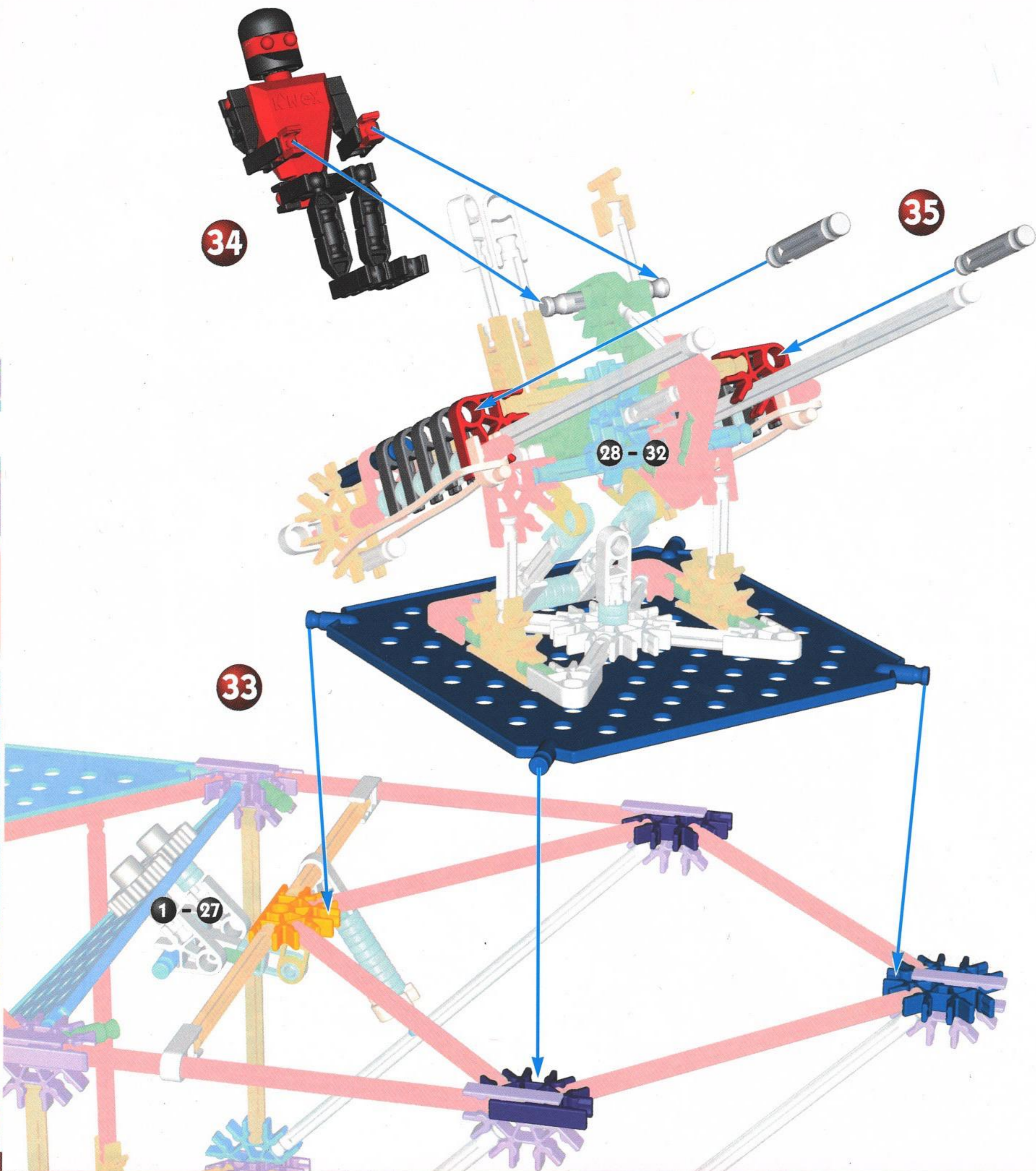

USA (GB) DO NOT LAUNCH IN THE DIRECTION OF PEOPLE, ANIMALS, OR WALLS; YOU COULD CAUSE INJURY OR DAMAGE.

F Ne PAS LANCER en direction de personnes, d'animaux ou de murs au risque de causer des blessures et des dommages.

I NON LANCIARE LA MACCHININA IN DIREZIONE DI PERSONE, ANIMALI O PARETI, ONDE EVITARE LESIONI O DANNI.

D DAS AUTO NIE IN RICHTUNG VON PERSONEN, TIEREN ODER WÄNDEN STARTEN, UM VERLETZUNGEN ODER SCHÄDEN ZU VERMEIDEN!

E NO LANZAR EL VEHÍCULO EN DIRECCIÓN A PERSONAS, ANIMALES O PAREDES, PUES ELLO PODRÍA PROVOCAR LESIONES O DAÑOS.

S SLÄPP INTE IVÄG BILEN MOT MÄNNISKOR, DJUR ELLER VÄGGAR; DET KAN ORSAKA SKADA.

DK BILEN MÅ IKKE STARTES HEN MOD MENNESKER, DYR OG VÆGGE, DA DEN KAN FORÅRSAGE PERSON- OG MATERIEL SKADE.

N UNNGÅ Å SENDE BILEN MOT PERSONER, DYR ELLER VEGGER, ETTERSOM DETTE KAN FORÅRSAKE SKADE ELLER ØDELEGGELSE.

SF ONNETTOMUUKSIEN JA VAHINKOJEN VÄLTÄMISEKSI ÄLÄ SUUNTA A AUTOA MUITA IHMISIÄ, ELÄIMIÄ TAI SEINIÄ KOHTI.

NL NIET IN DE RICHTING VAN MENSEN, DIEREN OF MUREN LANCEREN; DIT KAN LETSEL OF SCHADE VEROORZAKEN.

P NÃO LIBERTE O CARRO NA DIREÇÃO DE PESSOAS, ANIMAIS OU OBJECTOS, POIS TAL PODERÁ CAUSAR FERIMENTOS OU DANOS

G ΜΗΝ ΤΟ ΕΚΤΟΞΕΥΕΤΕ ΠΡΟΣ ΤΗ ΚΑΤΕΥΘΥΝΣΗ ΠΟΥ ΒΡΙΣΚΟΝΤΑΙ ΑΝΘΡΩΠΟΙ, ΖΩΑ Ή ΤΟΙΧΟΙ. ΜΠΟΡΕΙ ΝΑ ΠΡΟΚΑΛΕΣΕΤΕ ΤΡΑΥΜΑΤΙΣΜΟ Ή ΖΗΜΙΑ.

TR ARABAYI İNSANLARA, HAYVANLARA VE DUVARA DOĞRU HAREKETE GETİRMEYİN; AKSİ TAKDİRDE YARALANMA VEYA HASARA SEBEP OLABİLİRSİNİZ.

CHI 千萬不要朝著人群、動物或牆壁方向發射；否則可能會傷害人或毀壞車。

J 人や動物、壁に向けて走らせないこと。けがや破損の原因になります。

K 사람, 동물 또는 벽이 있는 쪽으로 출발시키지마십시오. 다치거나 손상될 수 있습니다.

IL אין לשחרר את המכונת בכיוון אנשים, חיות או קירות. פעולה כזו עלולה לגרום לפציעה או נזק.

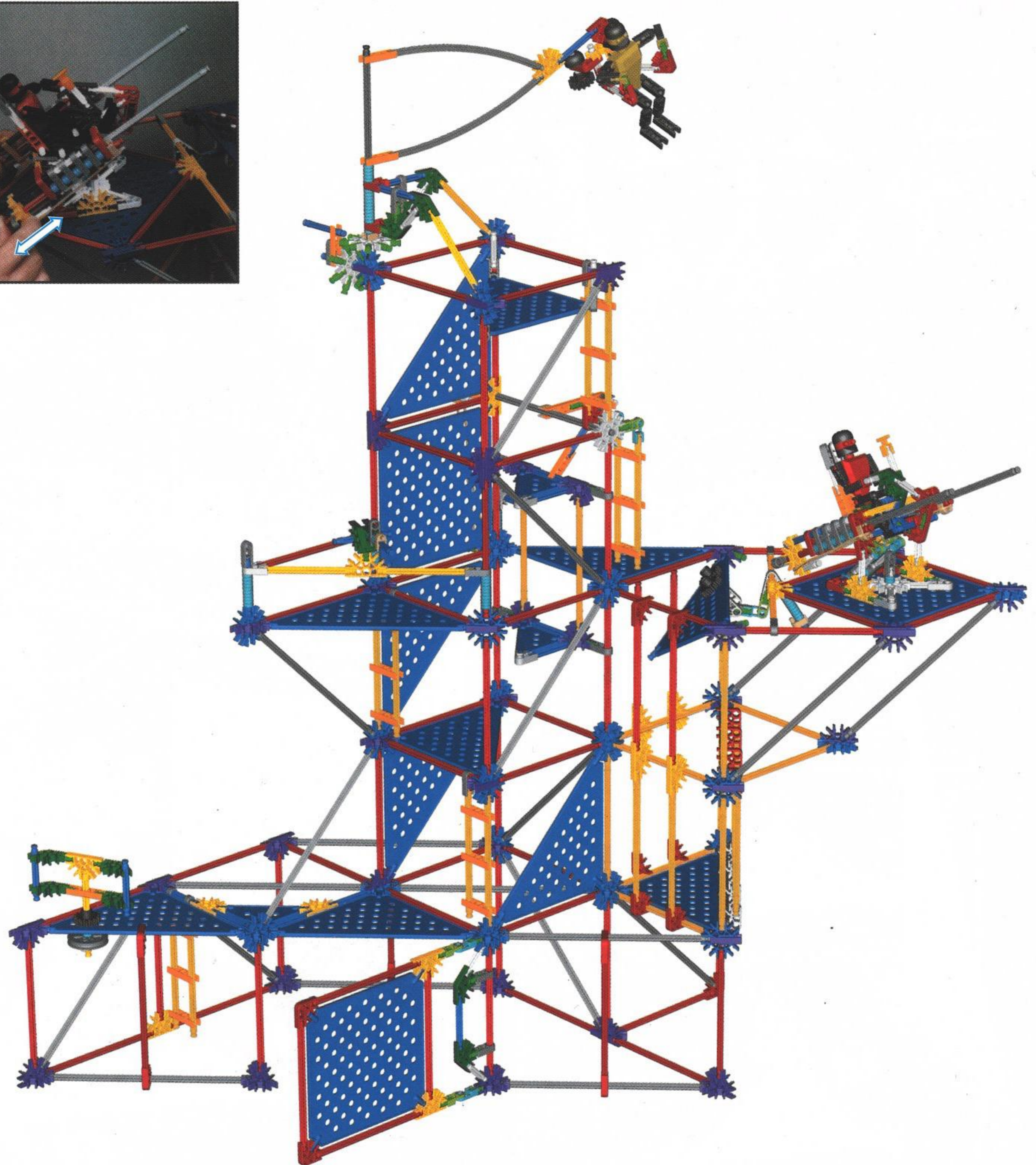
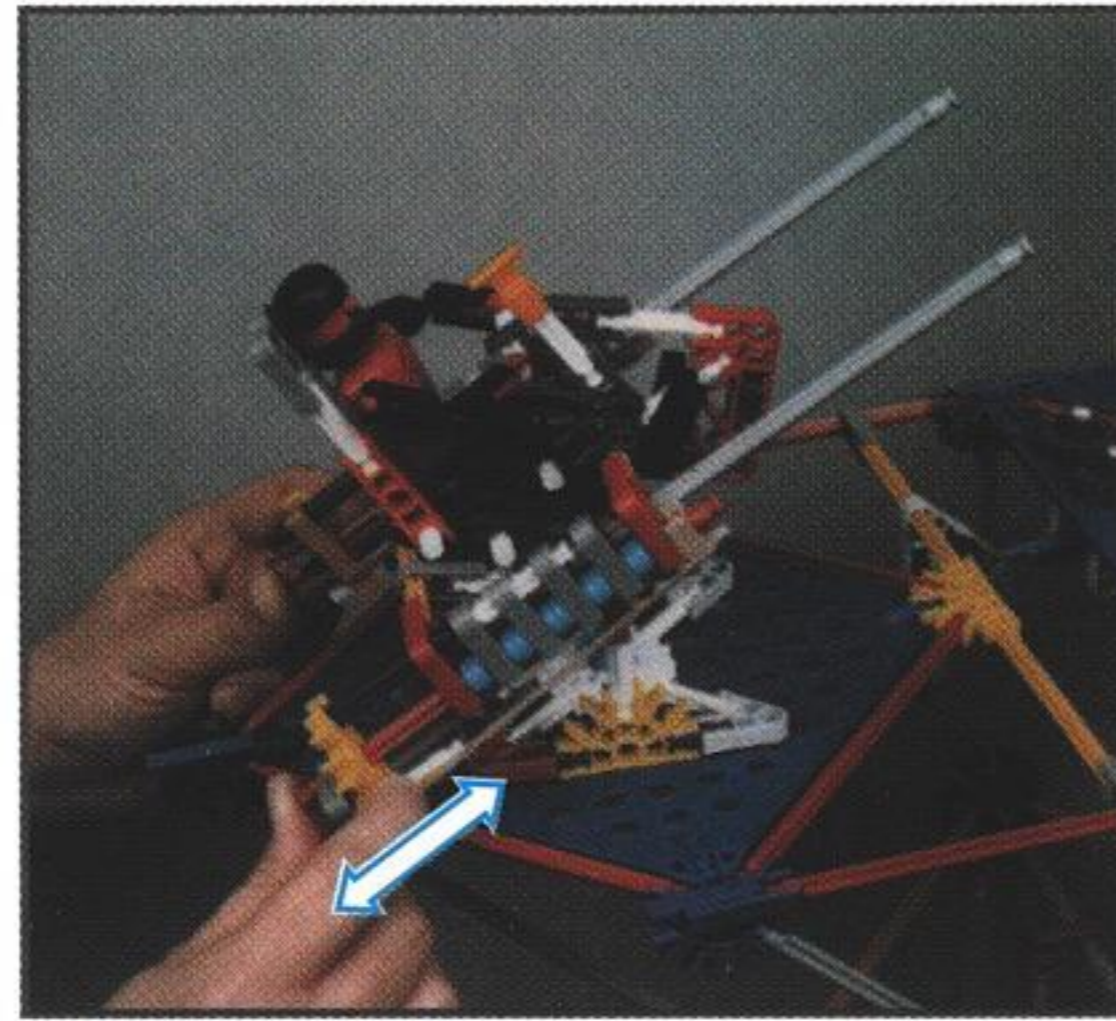

KDS Arena

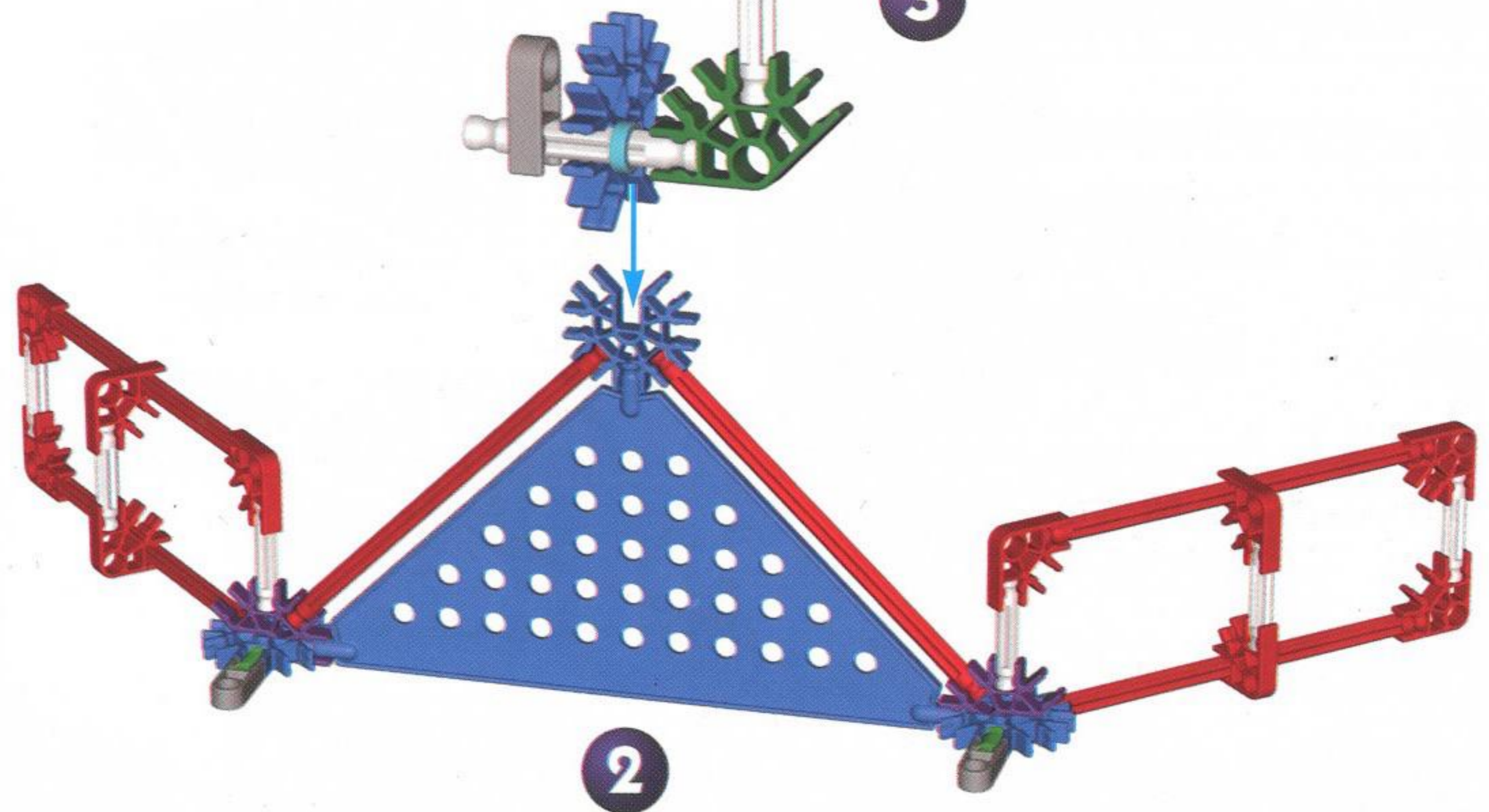
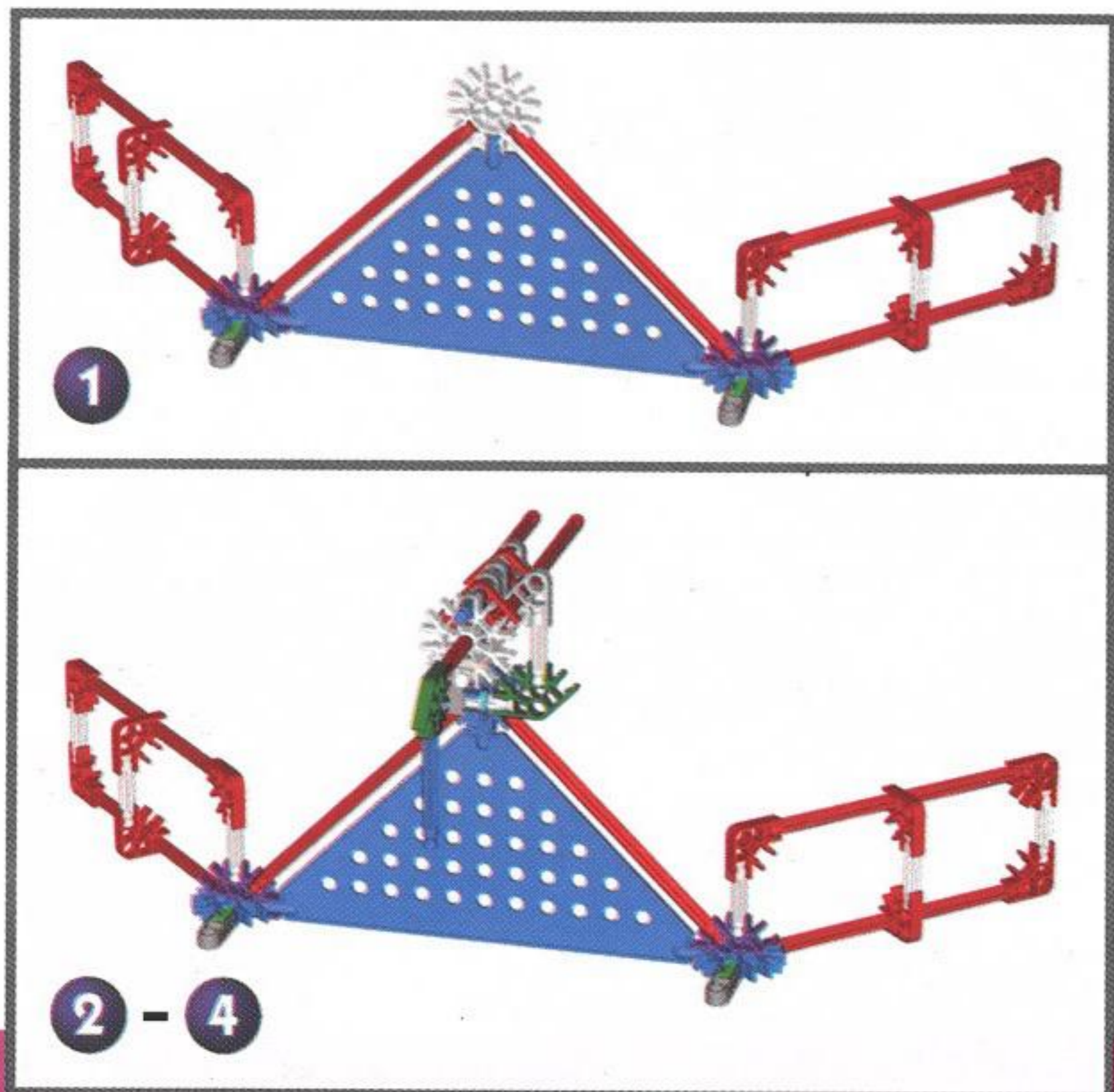
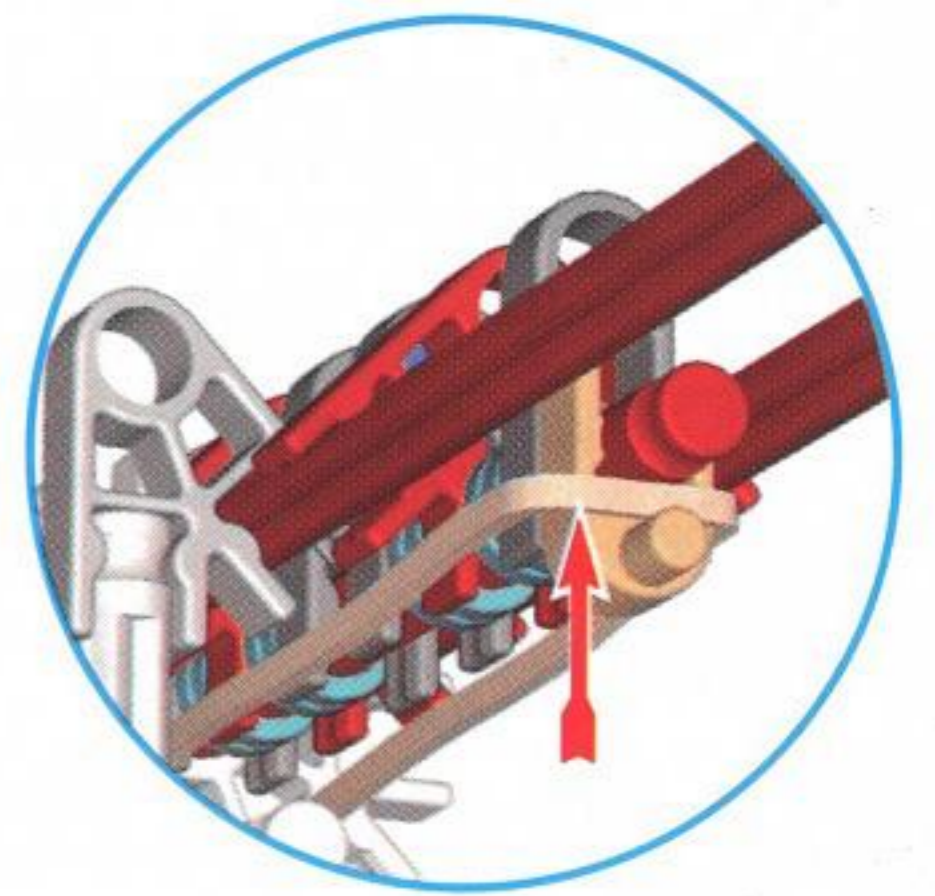
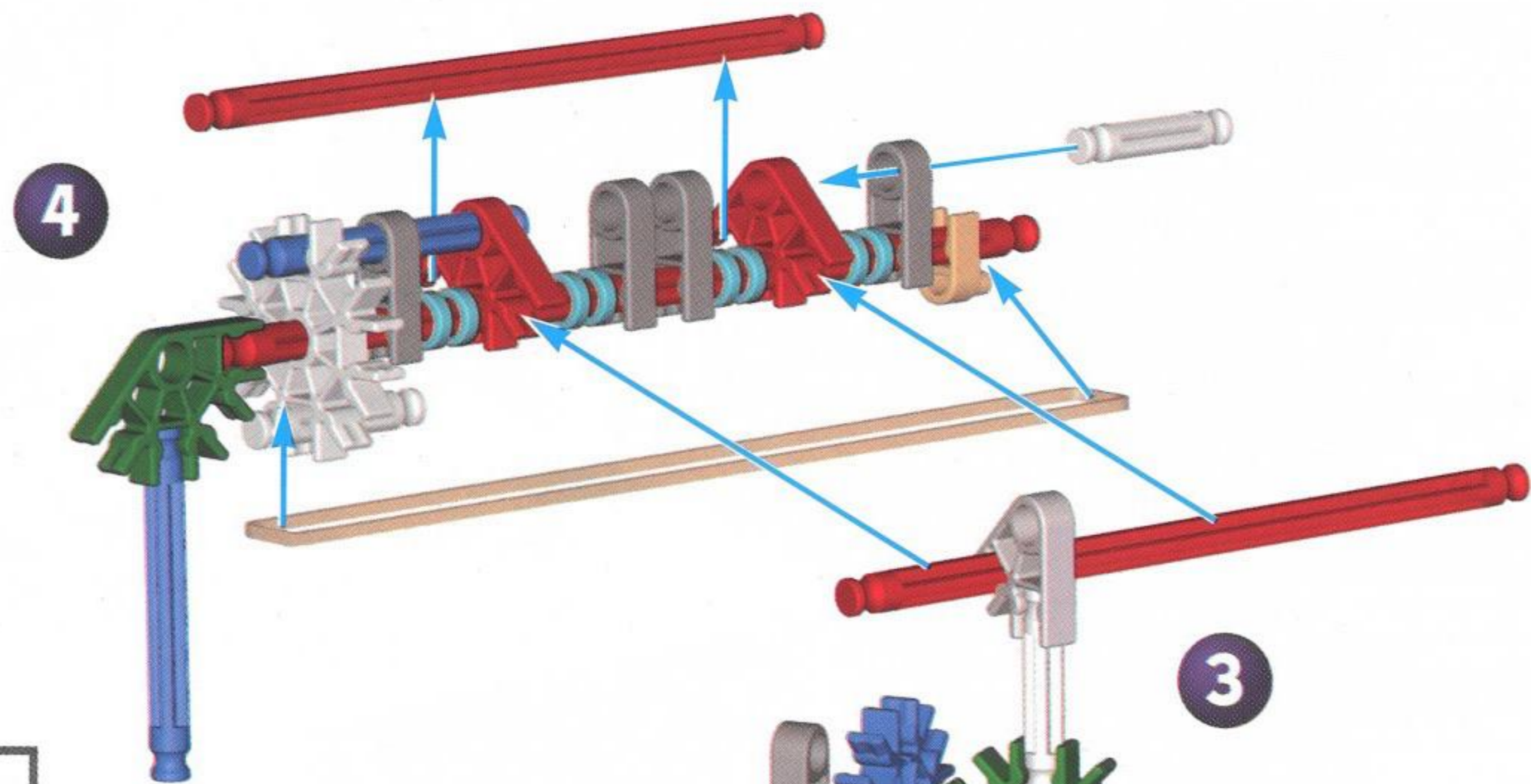
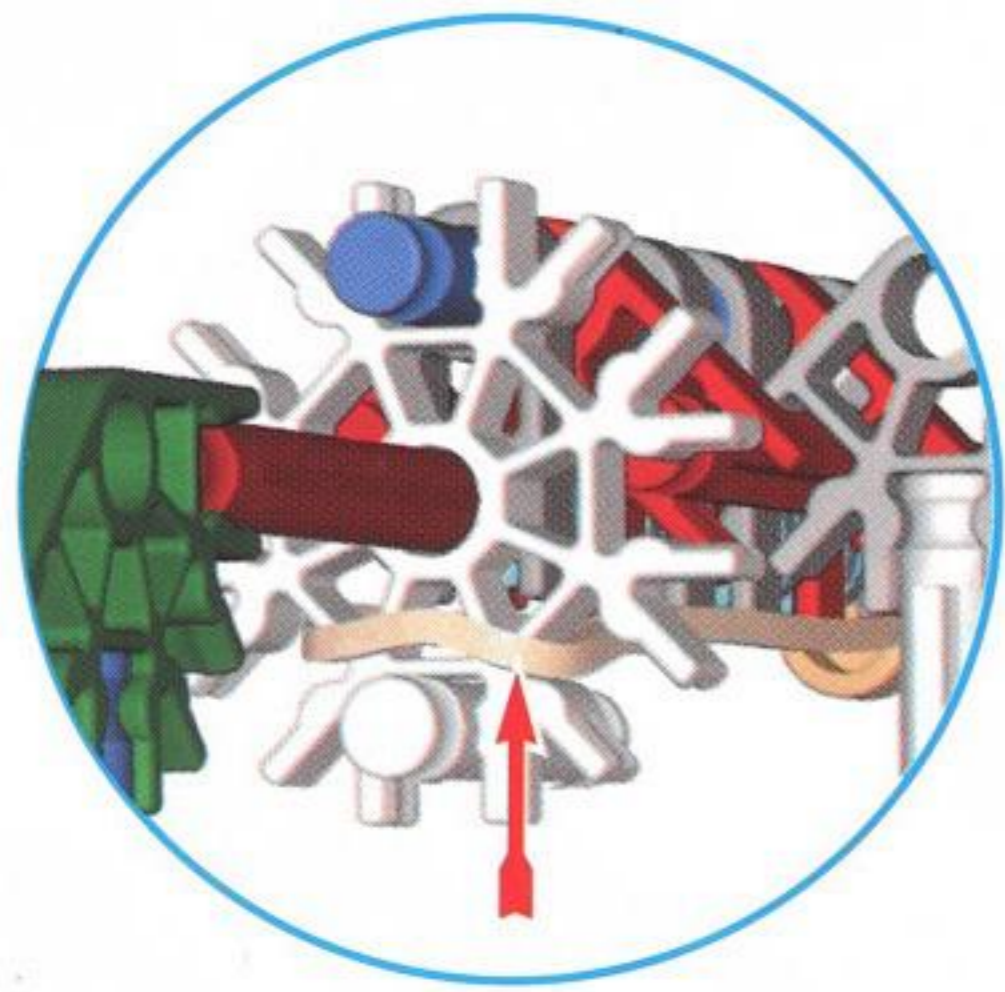
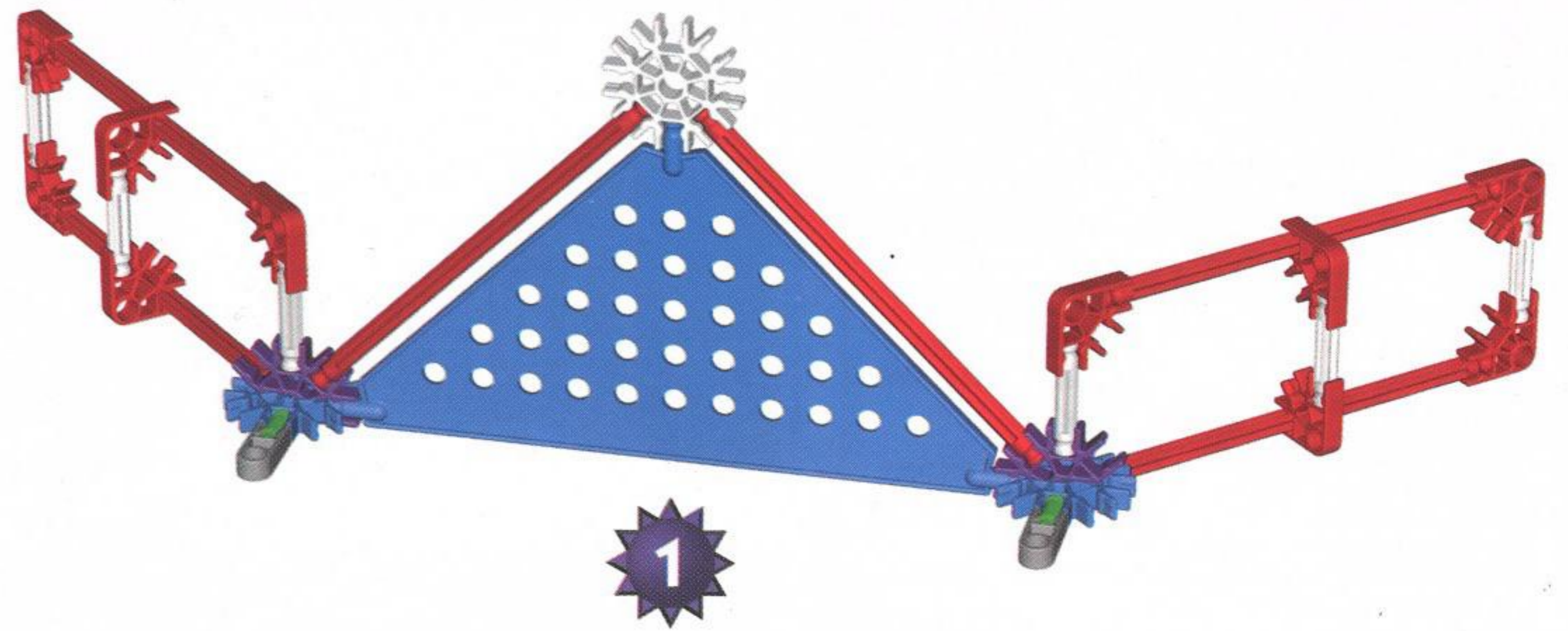
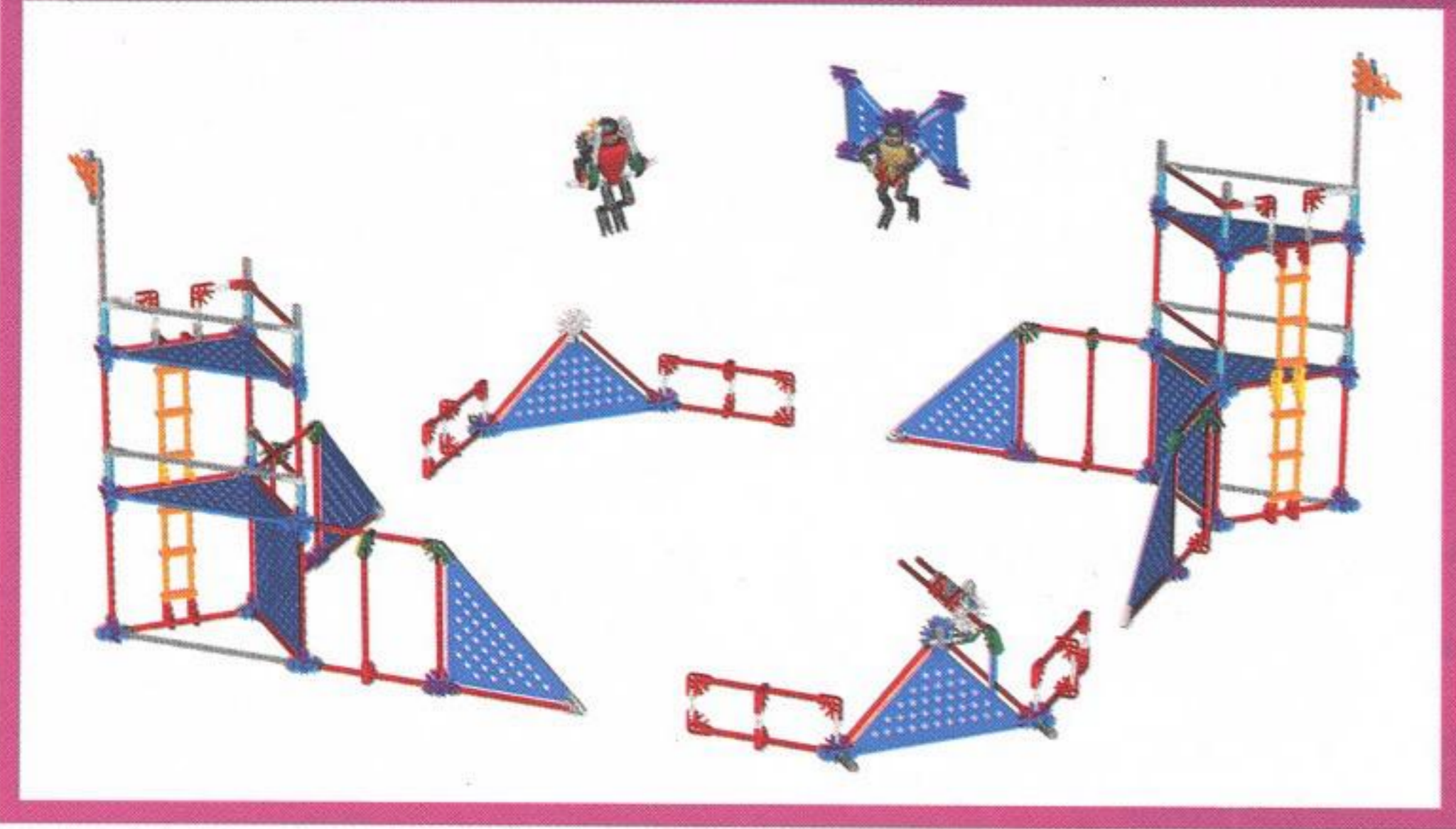

USA (GB) Build Steps 5-9 twice.

F Complétez deux fois les étapes 5 à 9.

I Eseguire per due volte le operazioni di cui ai punti 5 - 9.

D Führen Sie Schritte 5-9 zweimal aus.

E Realiza los pasos 5 a 9 dos veces.

S Utför steg 5-9 två gånger.

DK Trin 5-9 skal udføres to gange..

N Trinn 5-9 skal utføres to ganger.

SF Suorita rakennusvaiheet 5-9 kahdesti.

NL Stappen 5-9 twee keer bouwen.

P Constrói os passos 5 a 9 duas vezes.

G Φτιάξτε τα στάδια 5-9 δύο φορές.

TR 5-9 arasındaki işlemleri iki kere yapın.

J ステップ5~9をもう一度繰り返してください。

CHI 重複步驟 5-9 兩次

K 단계 5-9를 두 번 반복하십시오.

IL בנה צעדים 9-5 פעמיים.

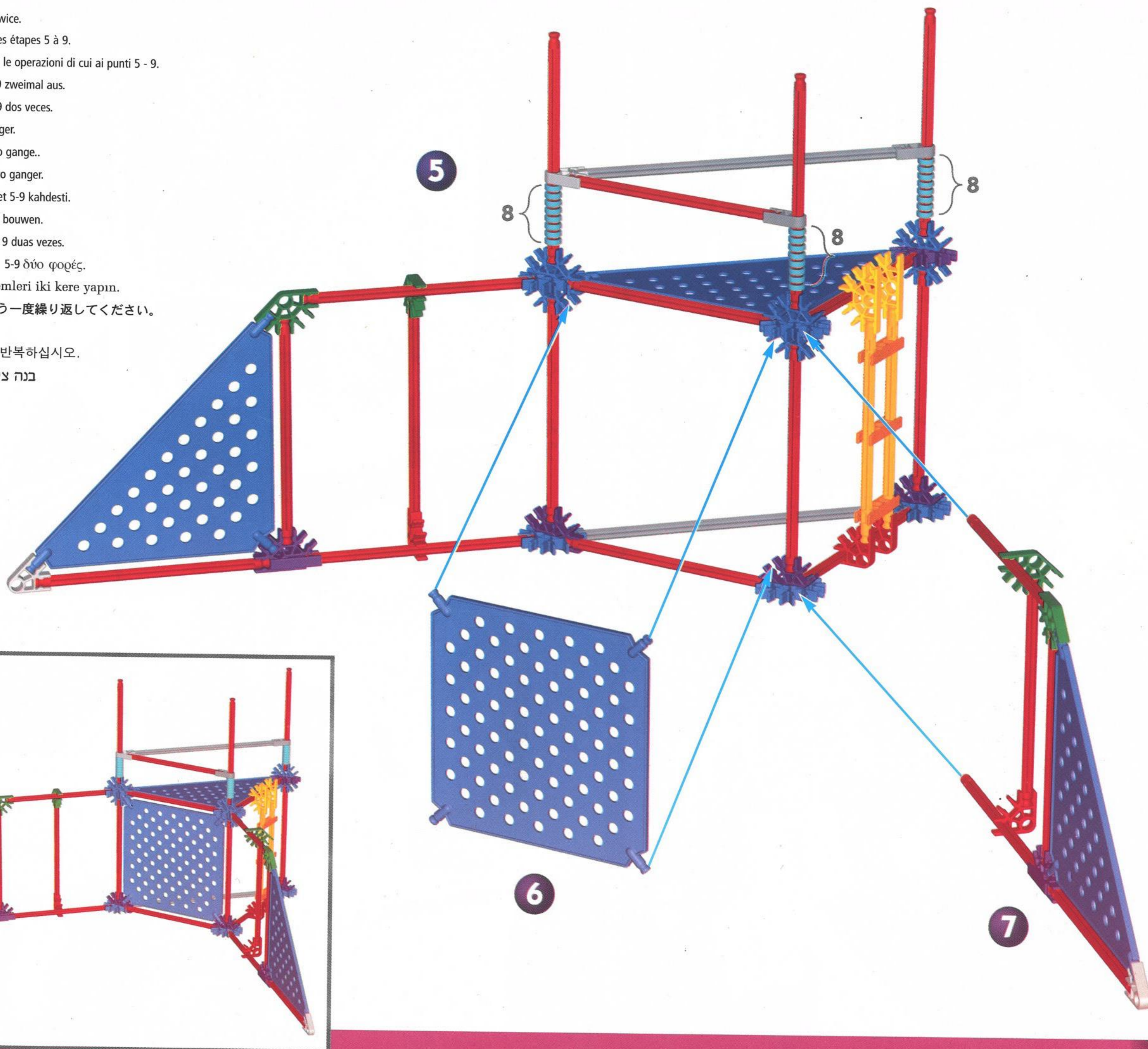

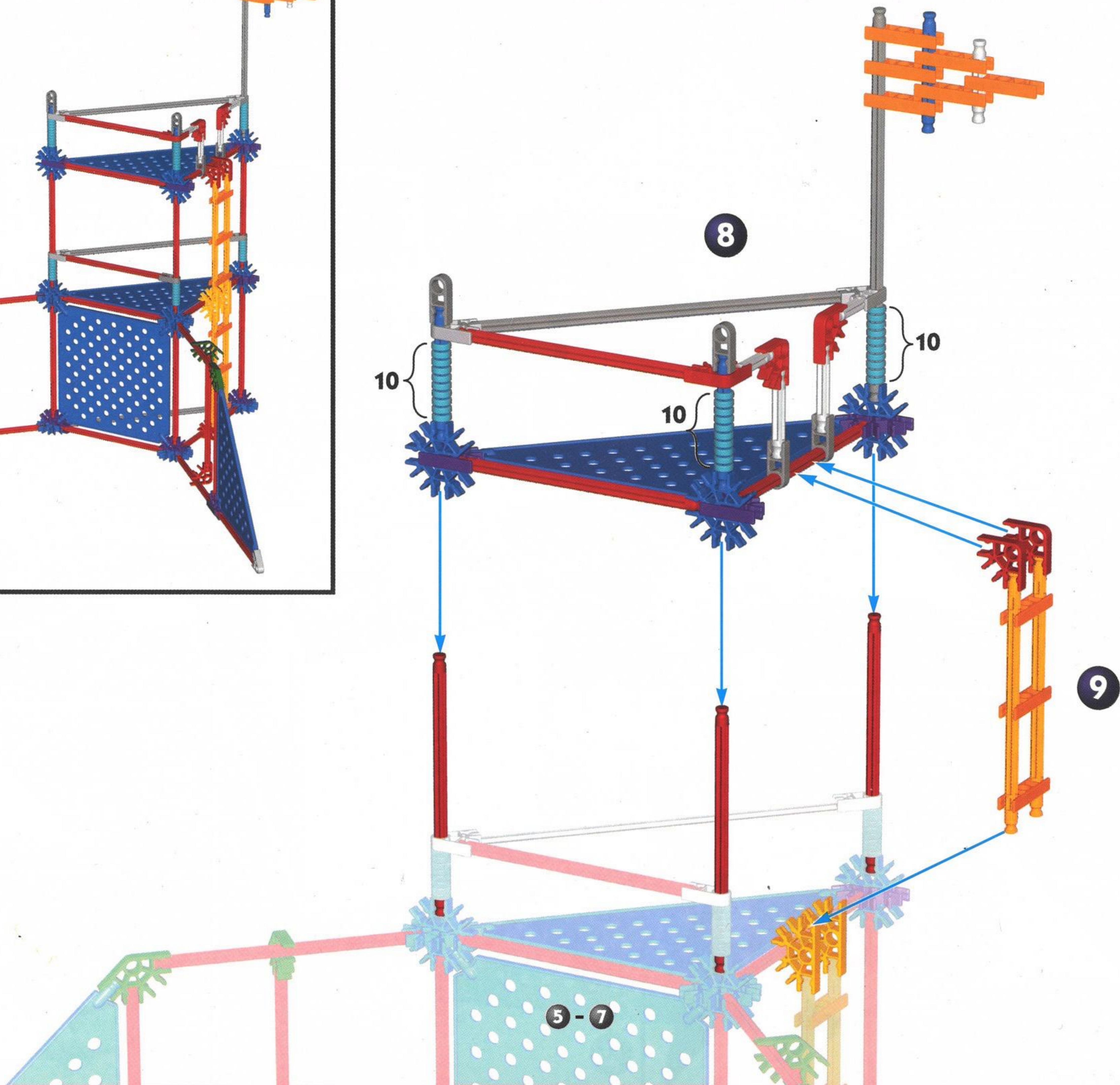

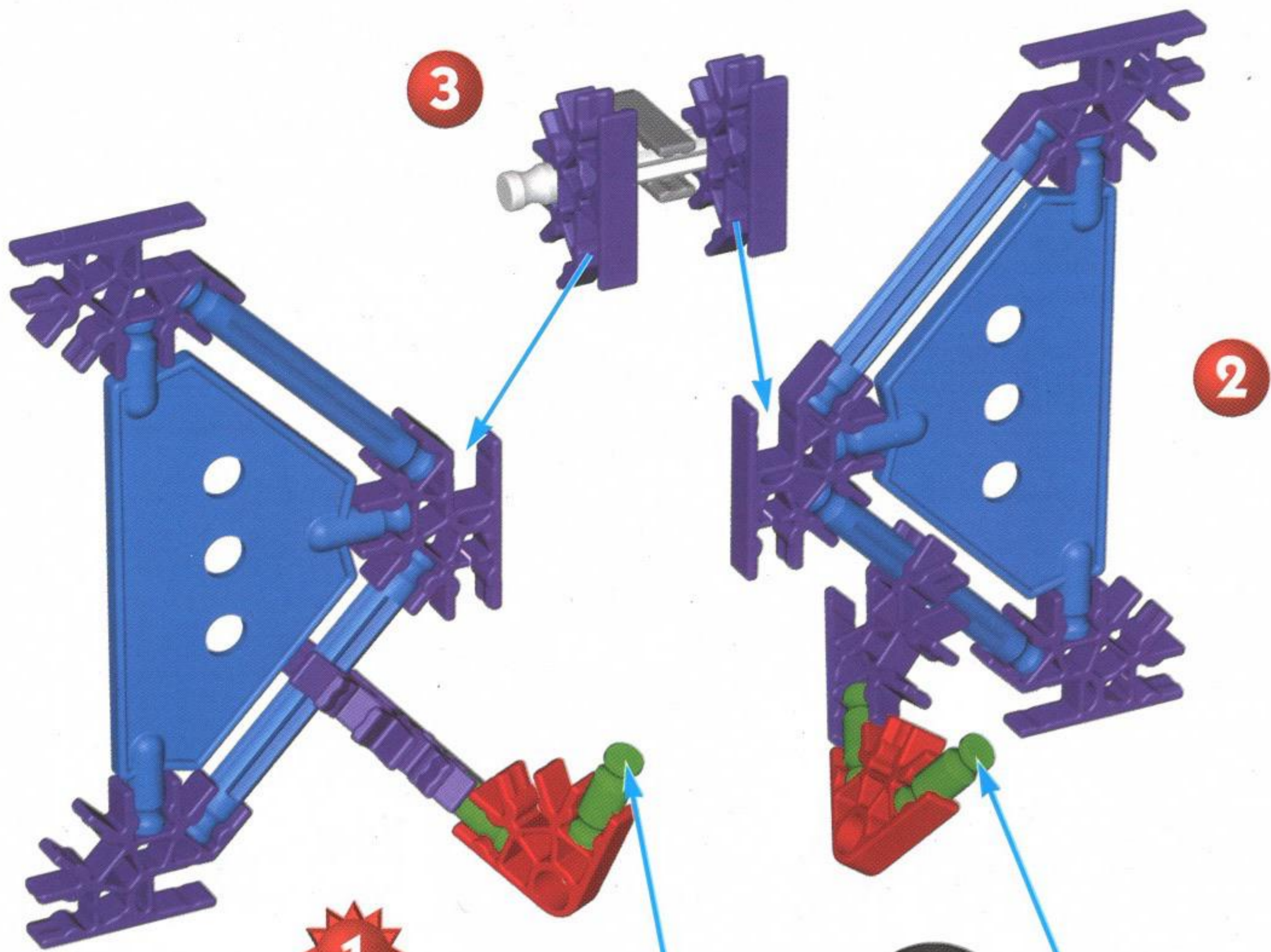

1

2

3

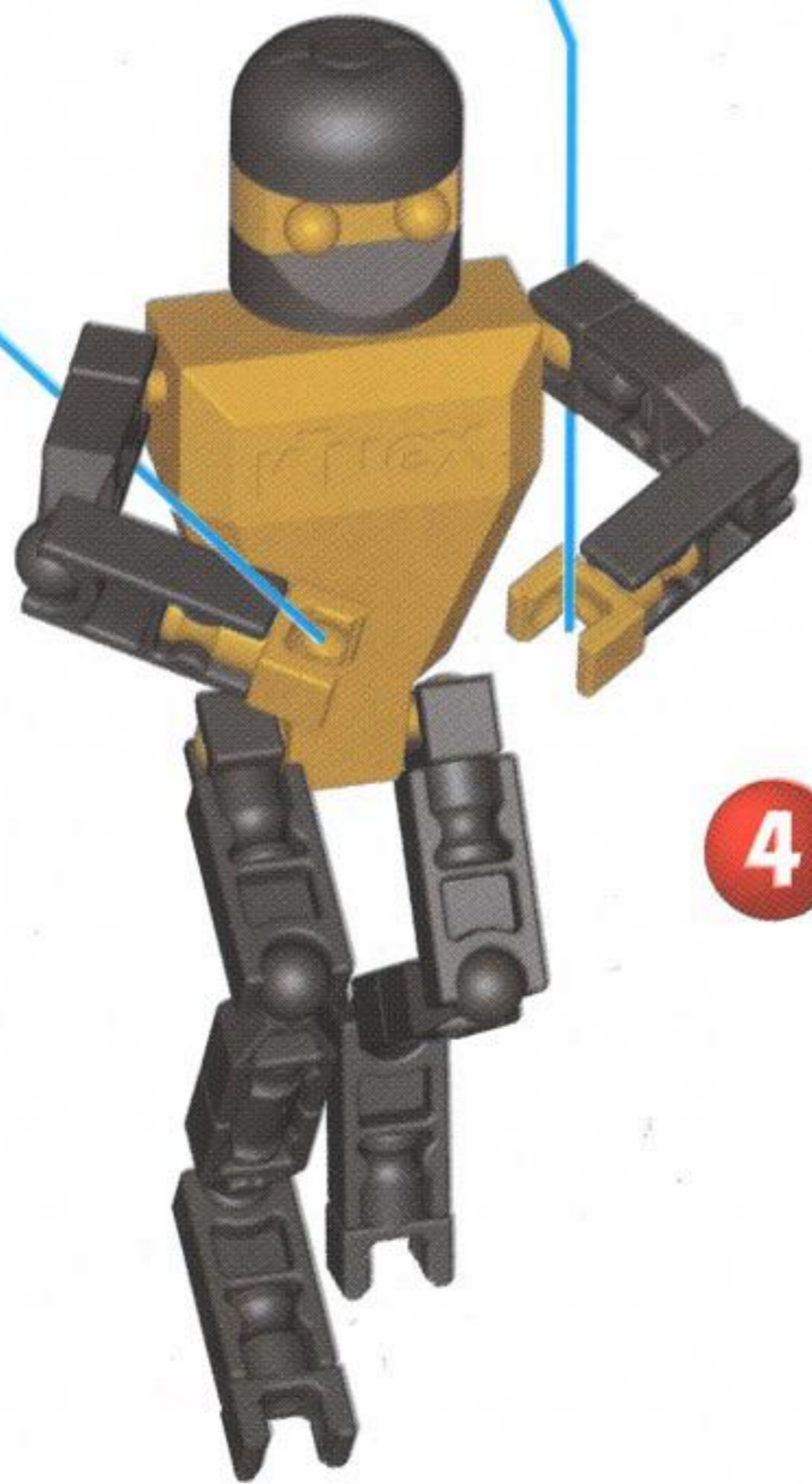

4

Gold Commander

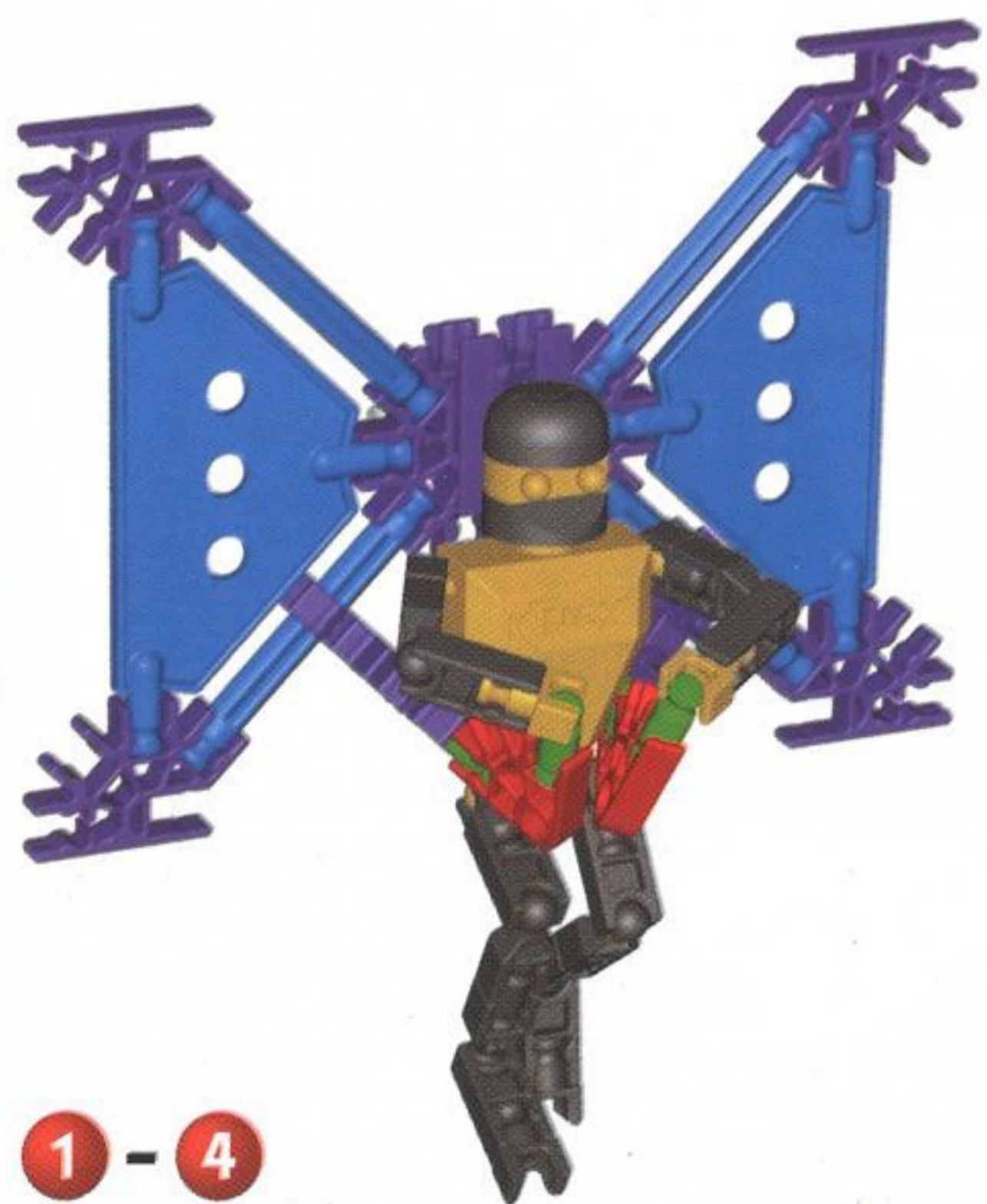

1 - 4

Red Team

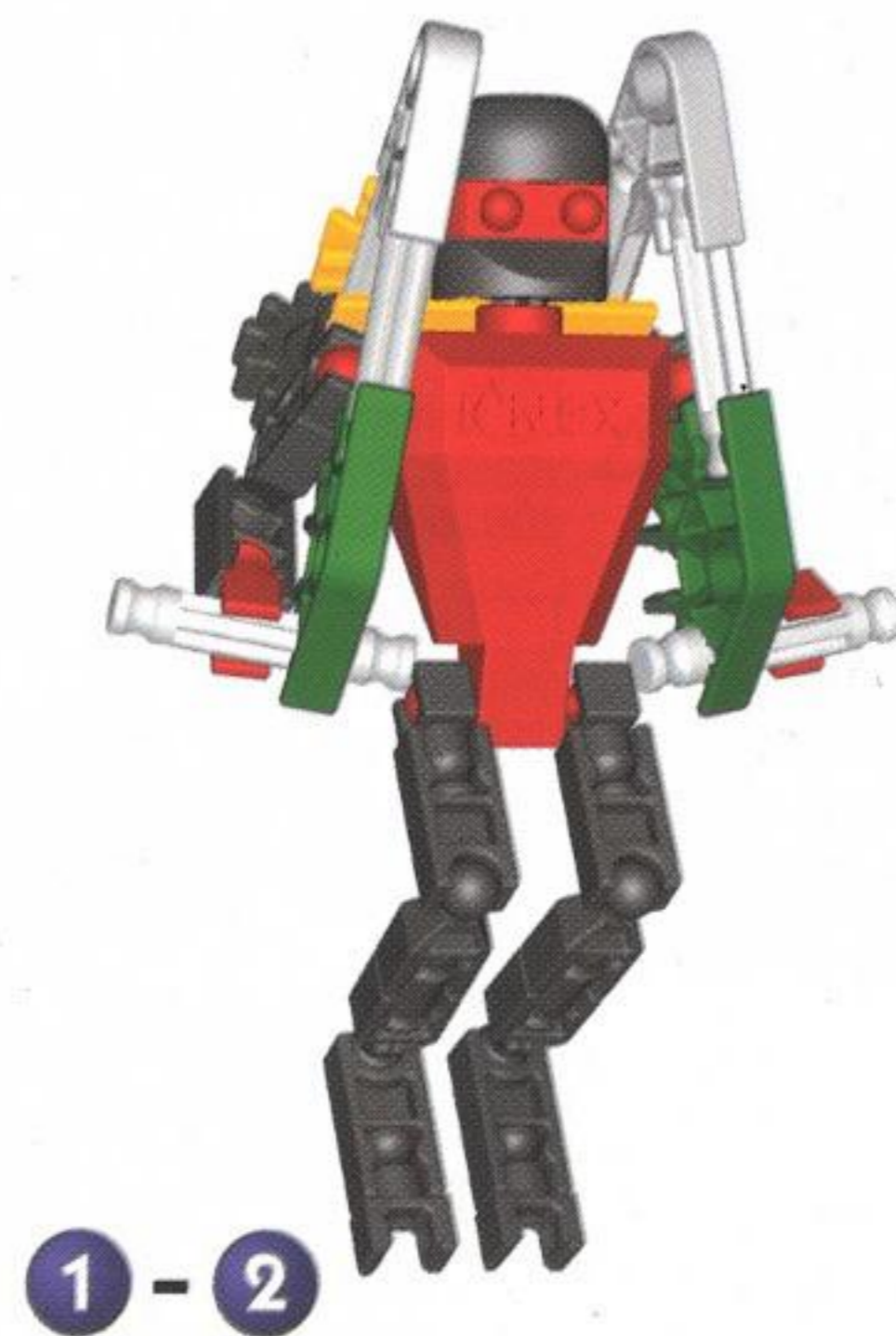

1 - 2

1



2

USA (GB) DO NOT LAUNCH IN THE DIRECTION OF PEOPLE, ANIMALS, OR WALLS; YOU COULD CAUSE INJURY OR DAMAGE.

F Ne PAS LANCER en direction de personnes, d'animaux ou de murs au risque de causer des blessures et des dommages.

I NON LANCIARE LA MACCHININA IN DIREZIONE DI PERSONE, ANIMALI O PARETI, ONDE EVITARE LESIONI O DANNI.

D DAS AUTO NIE IN RICHTUNG VON PERSONEN, TIEREN ODER WÄNDEN STARTEN, UM VERLETZUNGEN ODER SCHÄDEN ZU VERMEIDEN!

SF ONNETTOMUUKSIEN JA VAHINKOJEN VÄLTÄMISEKSI ÄLÄ SUUNTA AUTOA MUTTA IHMISIÄ, ELÄIMIÄ TAI SEINIÄ KOHTI.

S SLÄPP INTE IVÅG BILEN MOT MÄNNISKOR, DJUR ELLER VÄGGAR; DET KAN ORSAKA SKADA.

DK BILEN MÅ IKKE STARTES HEN MOD MENNESKER, DYR OG VÆGGE, DA DEN KAN FORÅRSAGE PERSON- OG MATERIEL SKADE.

N UNNGÅ Å SENDE BILEN MOT PERSONER, DYR ELLER VEGGER, ETTERSOM DETTE KAN FORÅRSAKE SKADE ELLER ØDELEGGELSE.

E NO LANZAR EL VEHÍCULO EN DIRECCIÓN A PERSONAS, ANIMALES O PAREDES, PUES ELLO PODRÍA PROVOCAR LESIONES O DAÑOS.

NL NIET IN DE RICHTING VAN MENSEN, DIEREN OF MUREN LANCEREN; DIT KAN LETSEL OF SCHADE VEROORZAKEN.

P NÃO LIBERTE O CARRO NA DIREÇÃO DE PESSOAS, ANIMAIS OU OBJECTOS, POIS TAL PODERÁ CAUSAR FERIMENTOS OU DANOS.

G ΜΗΝ ΤΟ ΕΚΤΟΞΕΥΕΤΕ ΠΡΟΣ ΤΗ ΚΑΤΕΥΘΥΝΣΗ ΠΟΥ ΒΡΙΣΚΟΝΤΑΙ ΑΝΘΡΩΠΟΙ, ΖΩΑ Ή ΤΟΙΧΟΙ. ΜΠΟΡΕΙ ΝΑ ΠΡΟΚΑΛΕΣΕΤΕ ΤΡΑΥΜΑΤΙΣΜΟ Ή ΖΗΜΙΑ.

TR ARABAYI İNSANLARA, HAYVANLARA VE DUVARA DOĞRU HAREKETE GETİRMEYİN; AKSİ TAKDİRDE YARALANMA VEYA HASARA SEBEP OLABİLİRSİNİZ.

CHI 千萬不要朝著人群、動物或牆壁方向發射；否則可能會傷害人或毀壞車。

J 人や動物、壁に向けて走らせないこと。けがや破損の原因になります。

K 사람, 동물 또는 벽이 있는 쪽으로 출발시키지마십시오. 다치거나 손상될 수 있습니다.

IL אין לשחרר את המכונת בכיוון אנשים, חיות או קירות. פעולה כזו עלולה לגרום לפציעה או נזק.

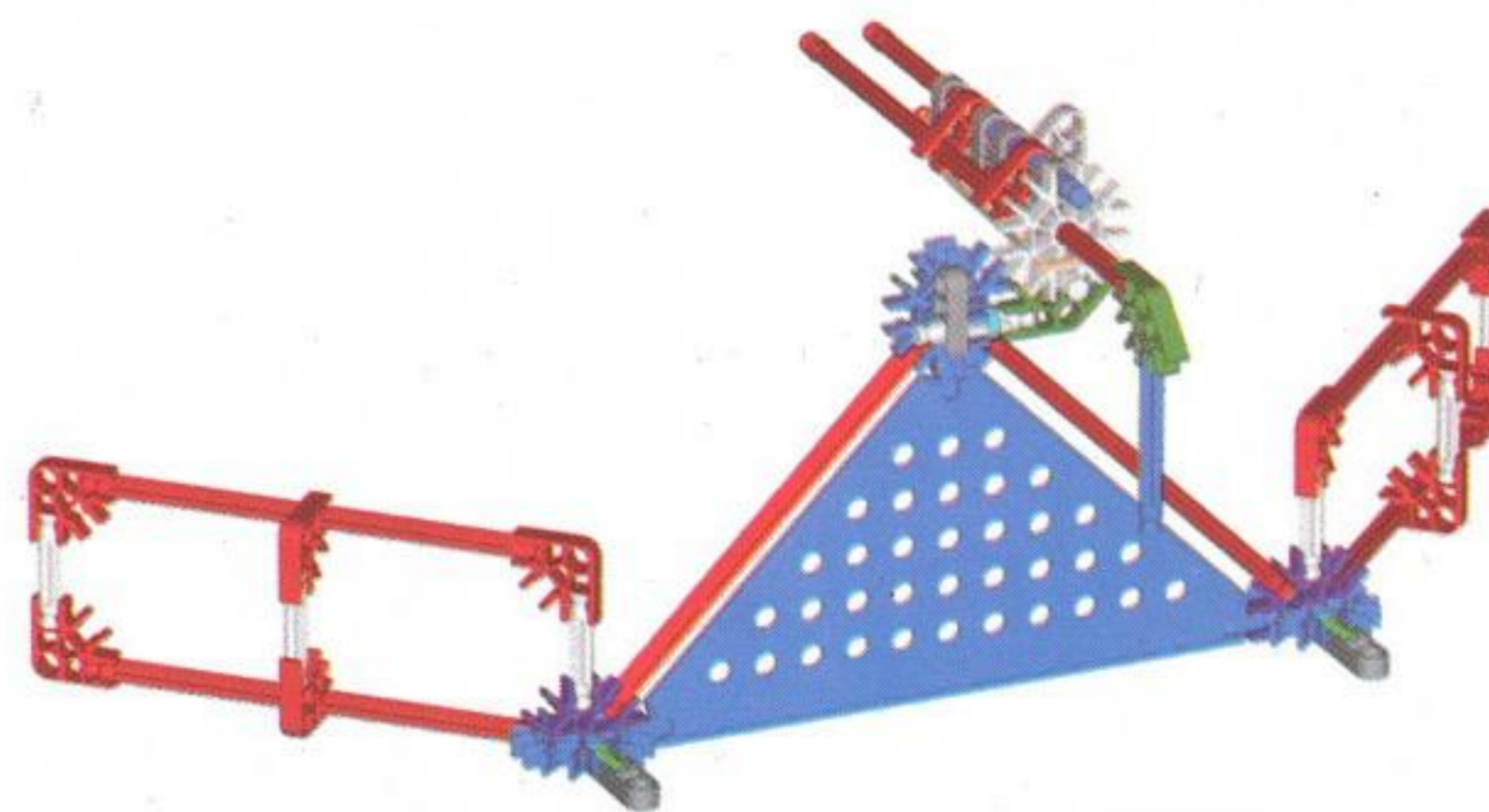
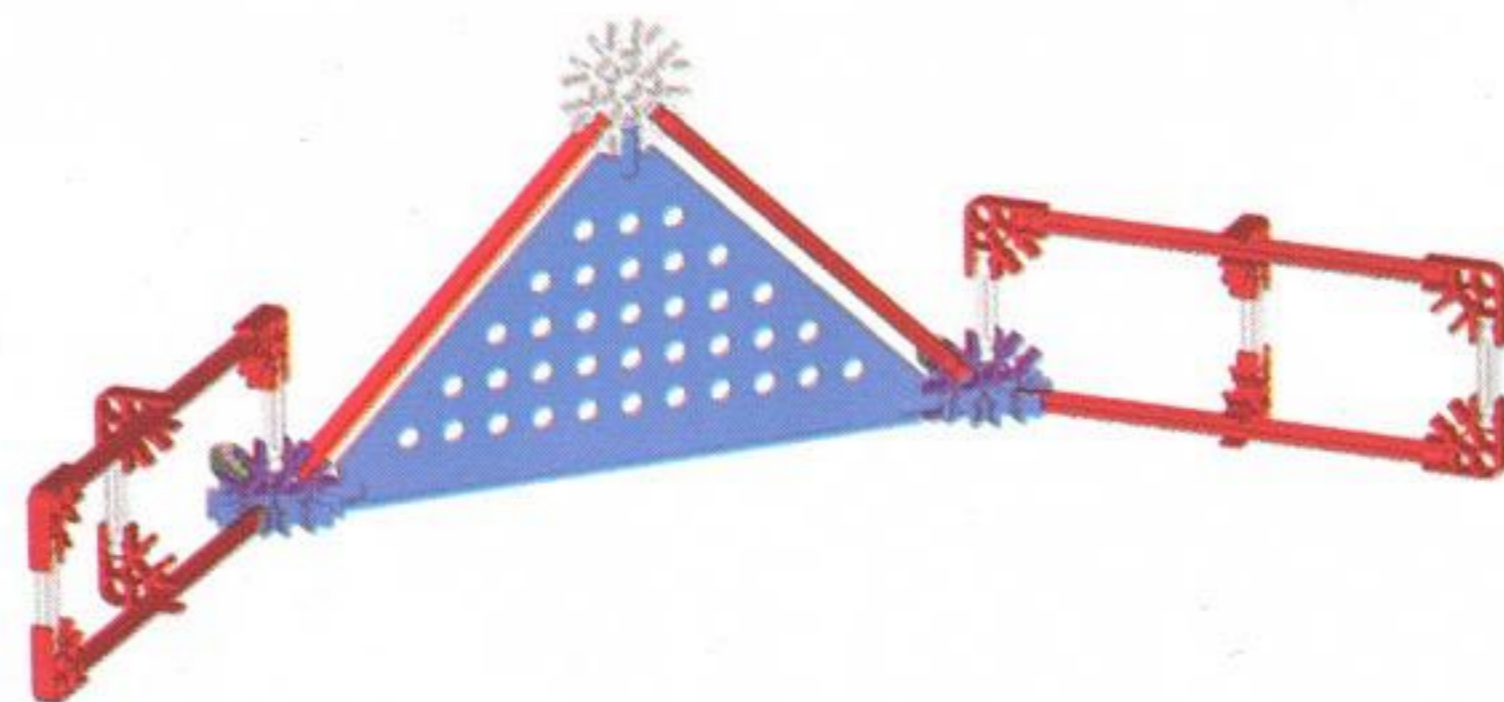
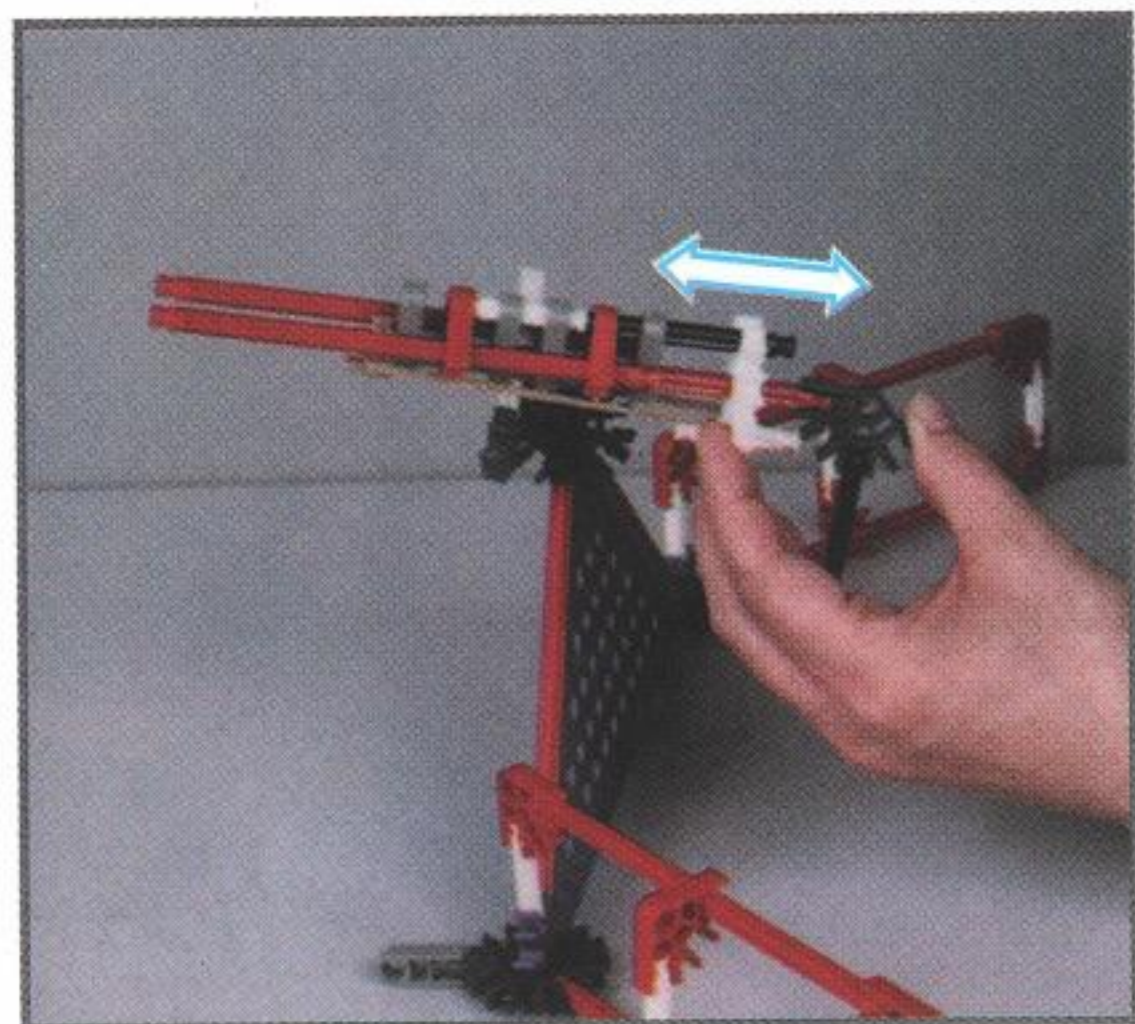

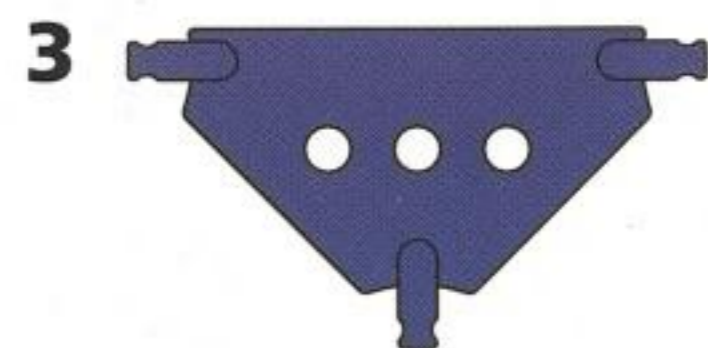
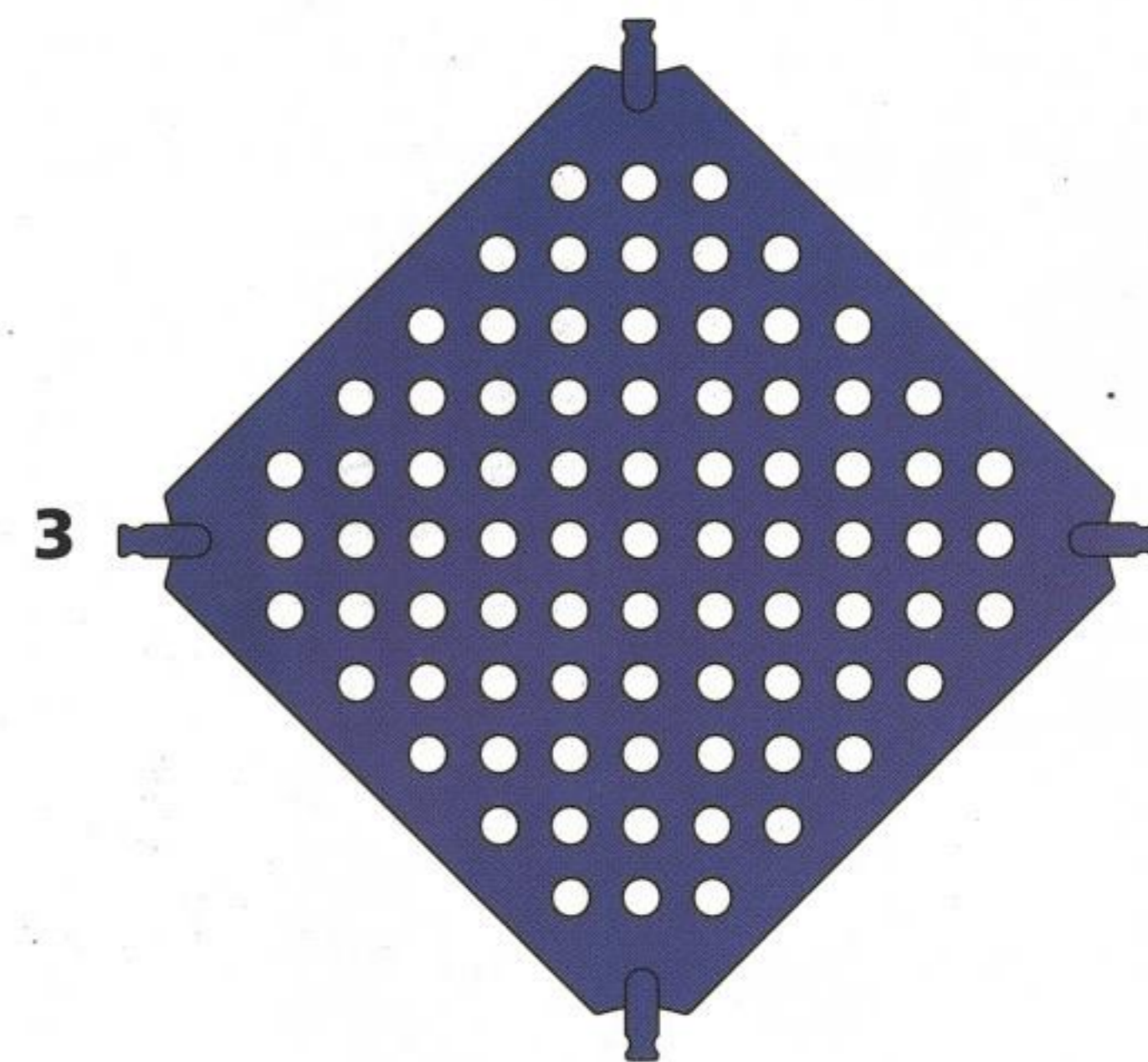
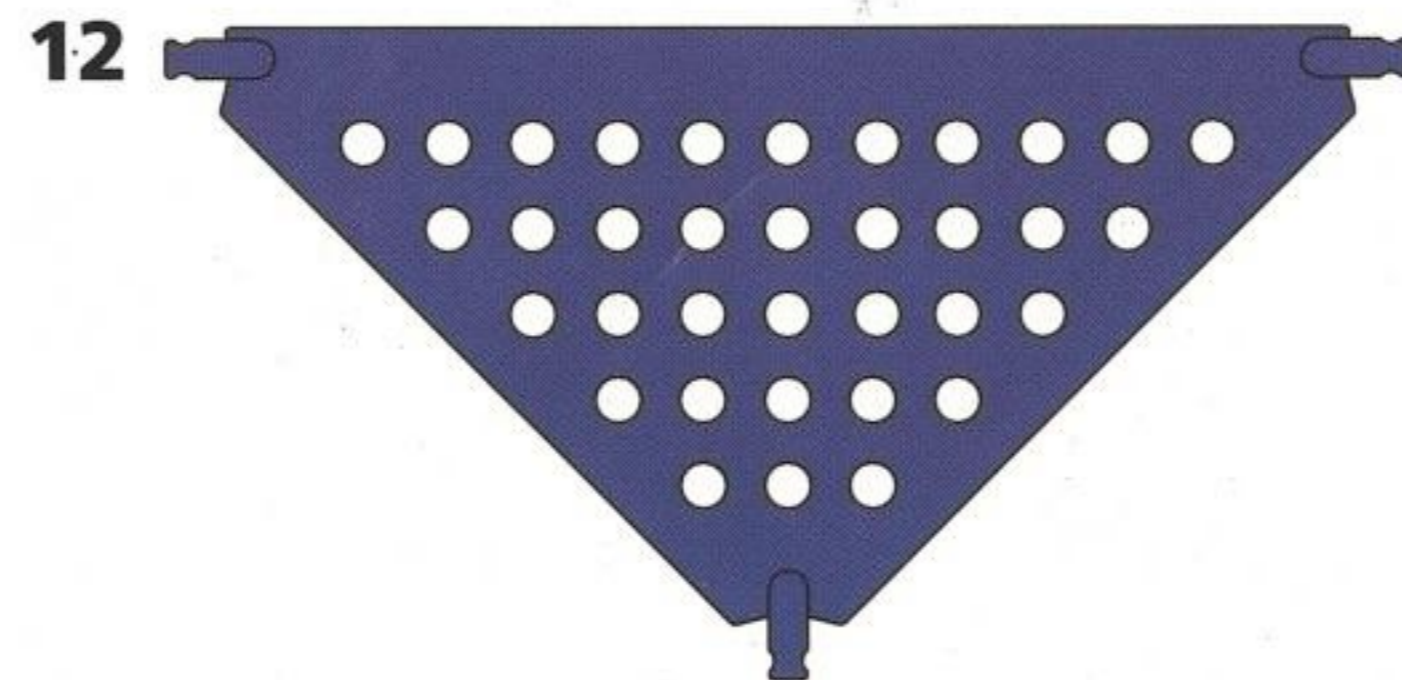
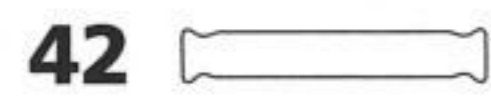
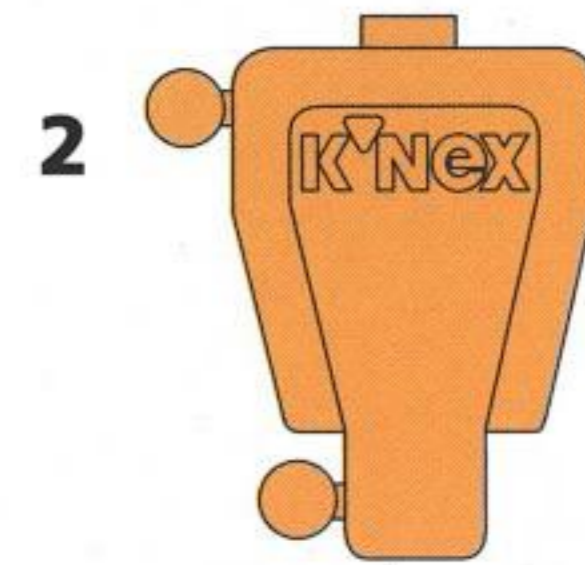
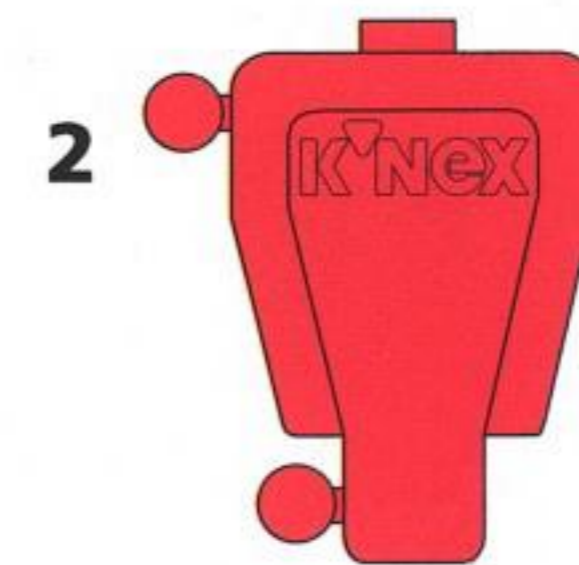
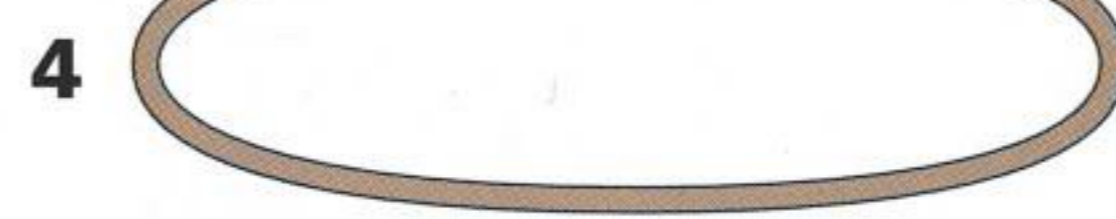
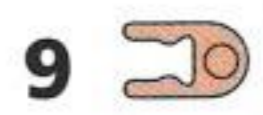
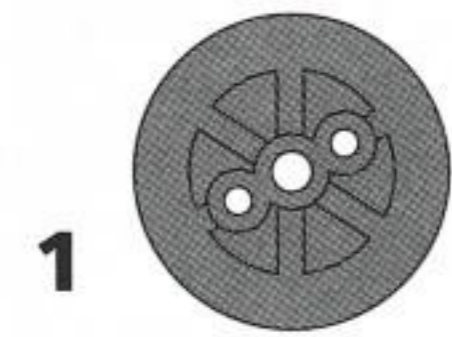
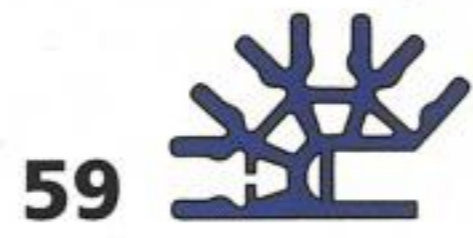
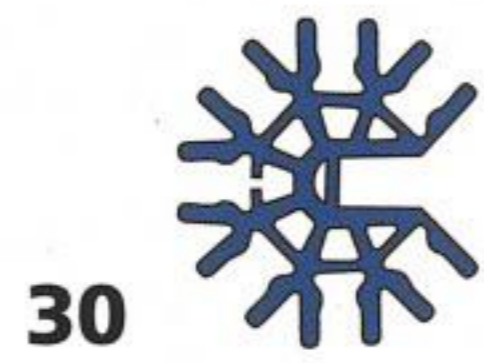
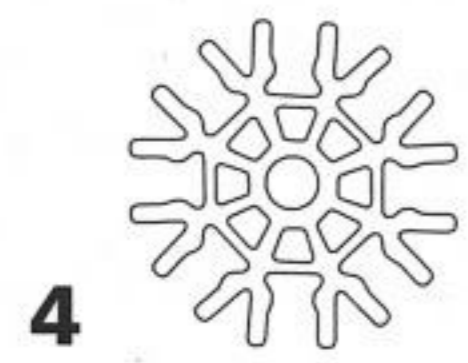

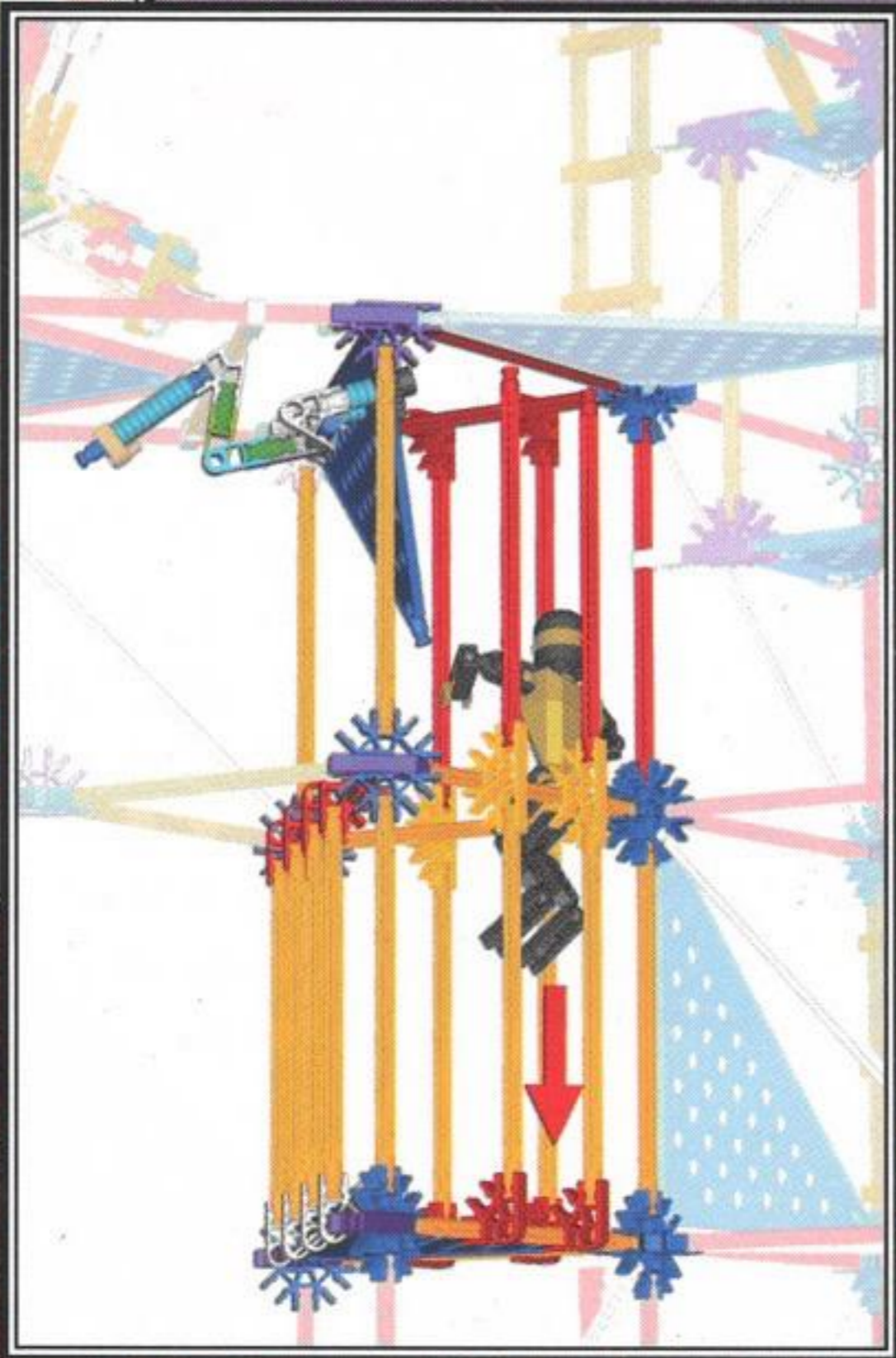
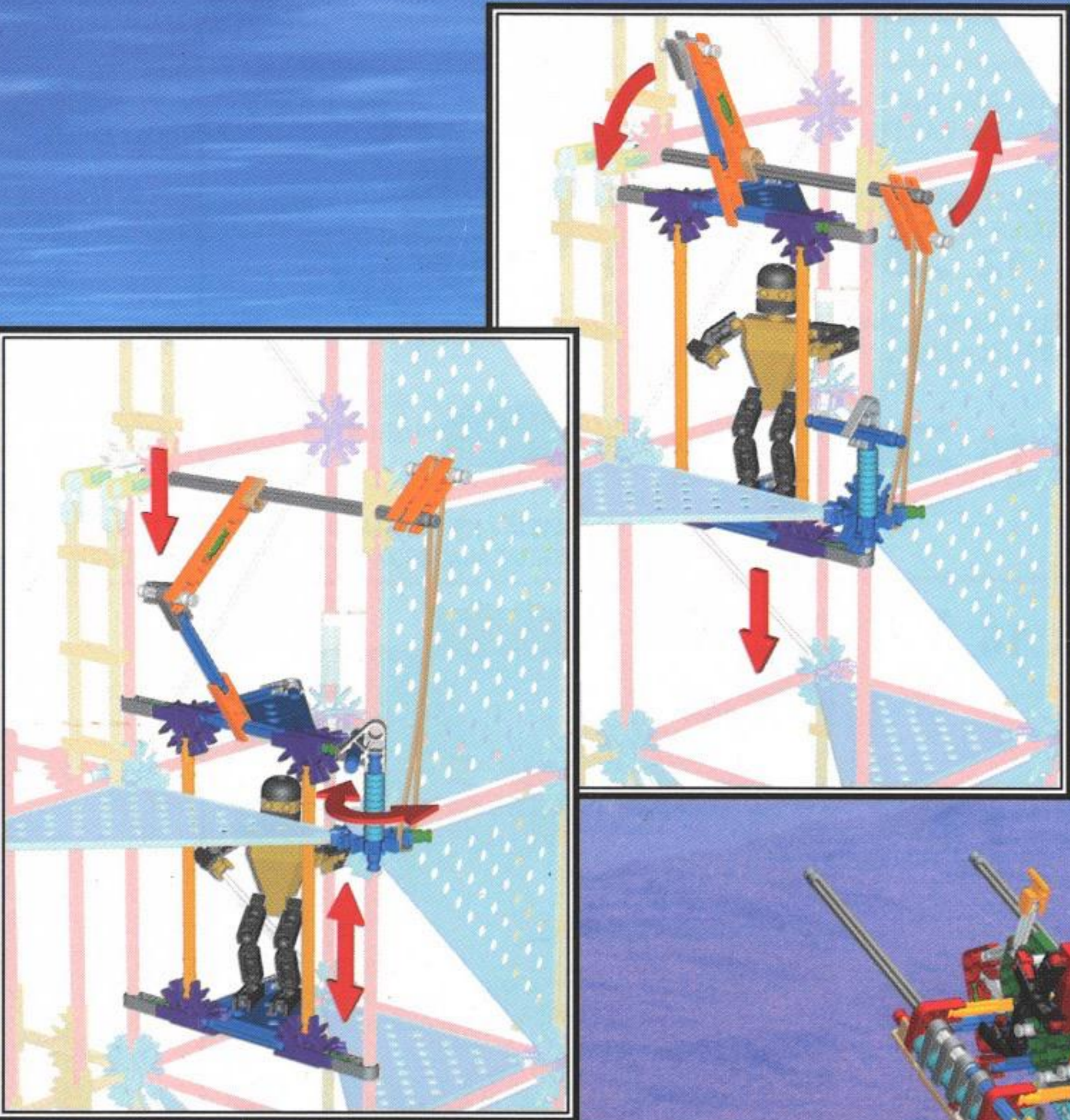

Back View
 Vue de dos
 Vista dal retro
 Ansicht von hinten
 Vista posterior
 Bakifrån
 Set bagfra
 Bakfra
 Takaa
 Achteraanzicht
 Vista posterior
 Πίσω όψη
 Arkadan görünüş
 後ろから見た図
 背部圖景
 תצוגה אחורית