



Beginner 40 Model Building Set

Construction Vehicle
page 1



Director's Chairs
page 8



House
page 10



Drawing Board
page 13



Ferris Wheel
page 15



Fish
page 20



Horse
page 22



Jet
page 26



Knight's Table
page 28



Ladder
page 33

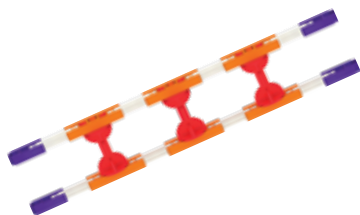

Merry-Go-Round
page 35



Oars
page 41

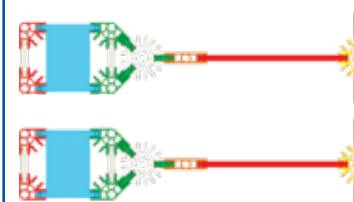

Pavilion
page 43

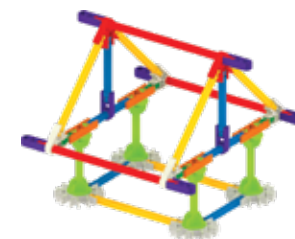

Pump Car
page 47



Rally Car
page 53

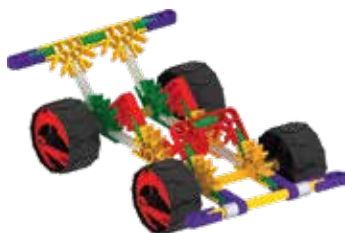

River Boat
page 57

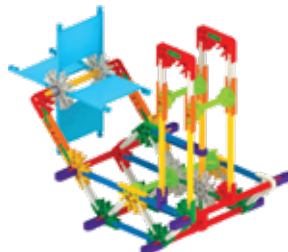

Row Boat
page 64

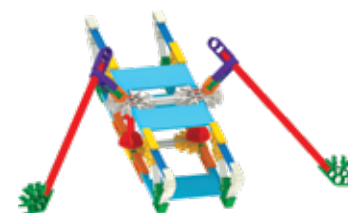

Shade Canopy
page 71

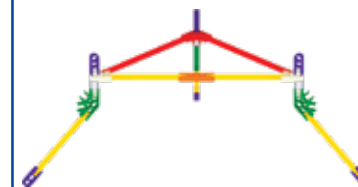



Beginner 40 Model Building Set Continued

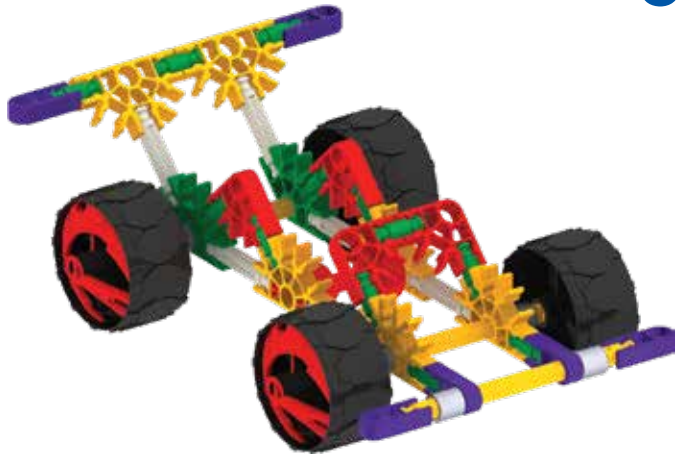

Stairway
page 74

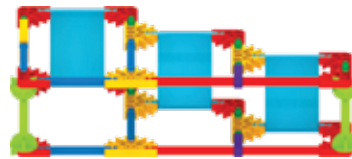

Stone Bridge
page 77



Stunt Kite
page 81

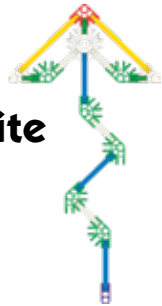

Train
page 82



Wagon
page 90



Windmill
page 96



Robot
page 104



Helicopter
page 106



Balancing Act
page 111

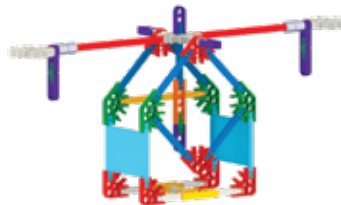

Crane
page 118

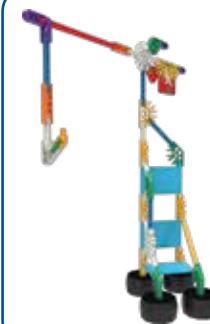

Skateboard
page 124



1

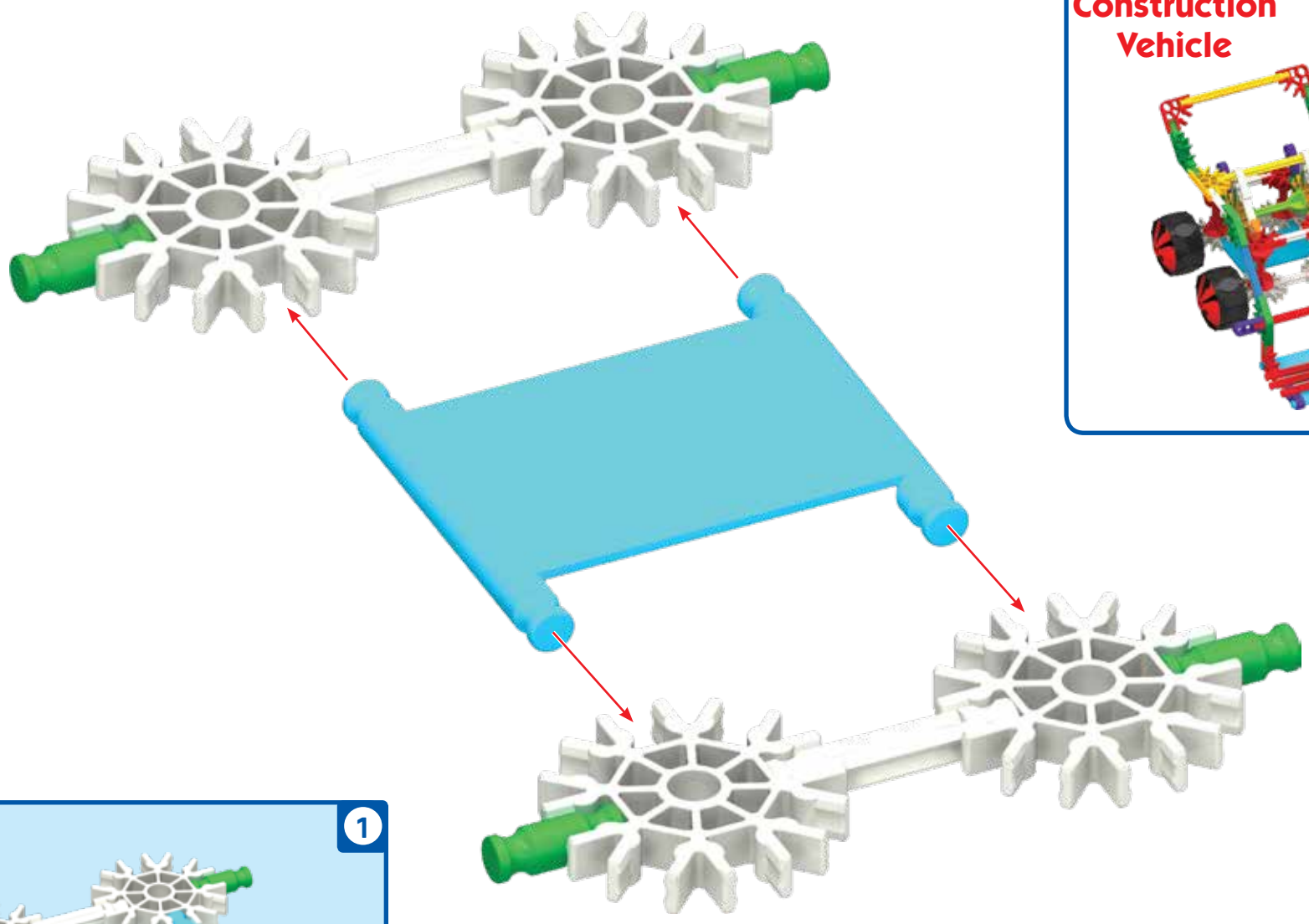

Construction Vehicle



1

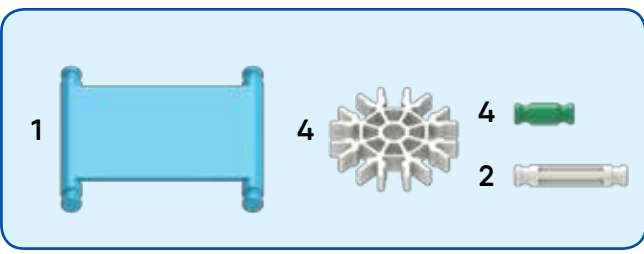
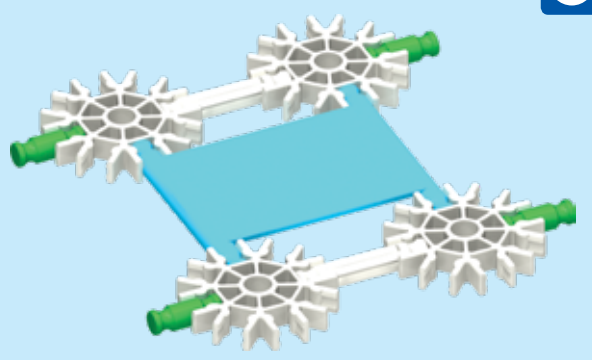

- 2 
- 4 
- 2 
- 2 
- 1 
- 2 
- 4 
- 8 

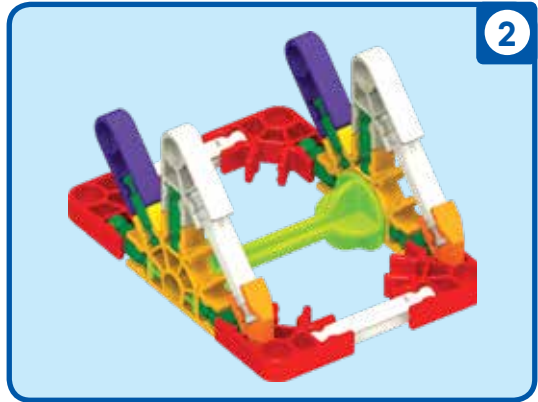
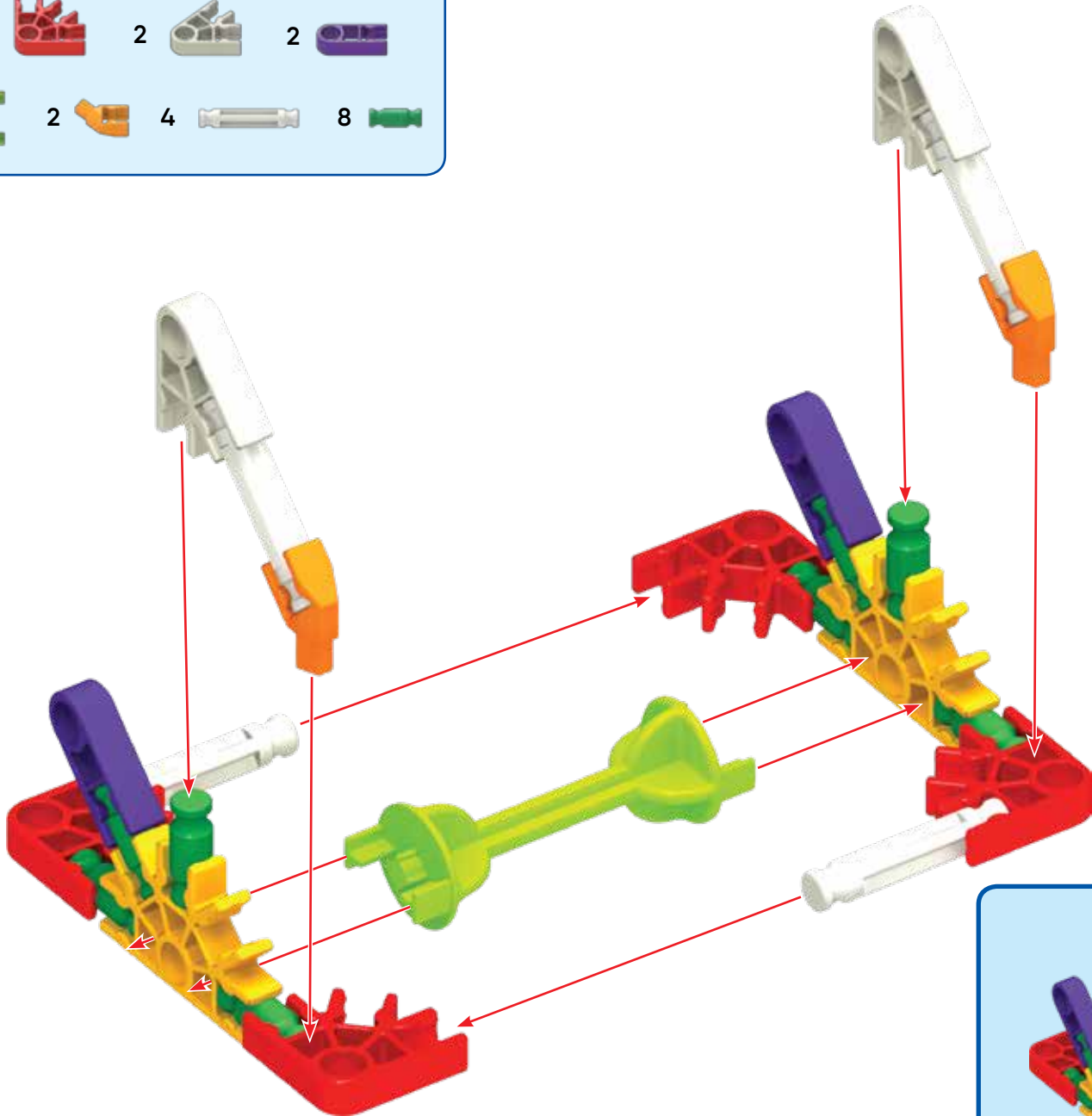

3

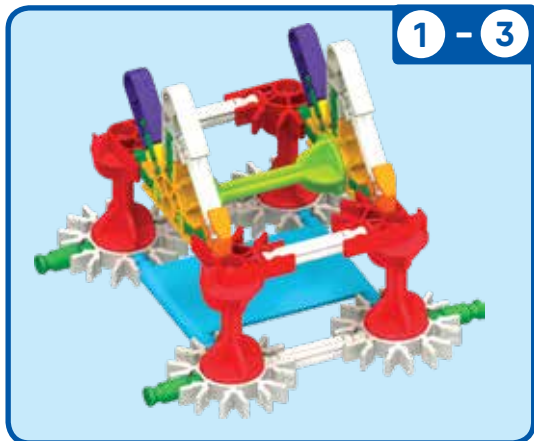
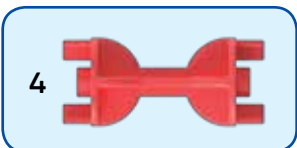
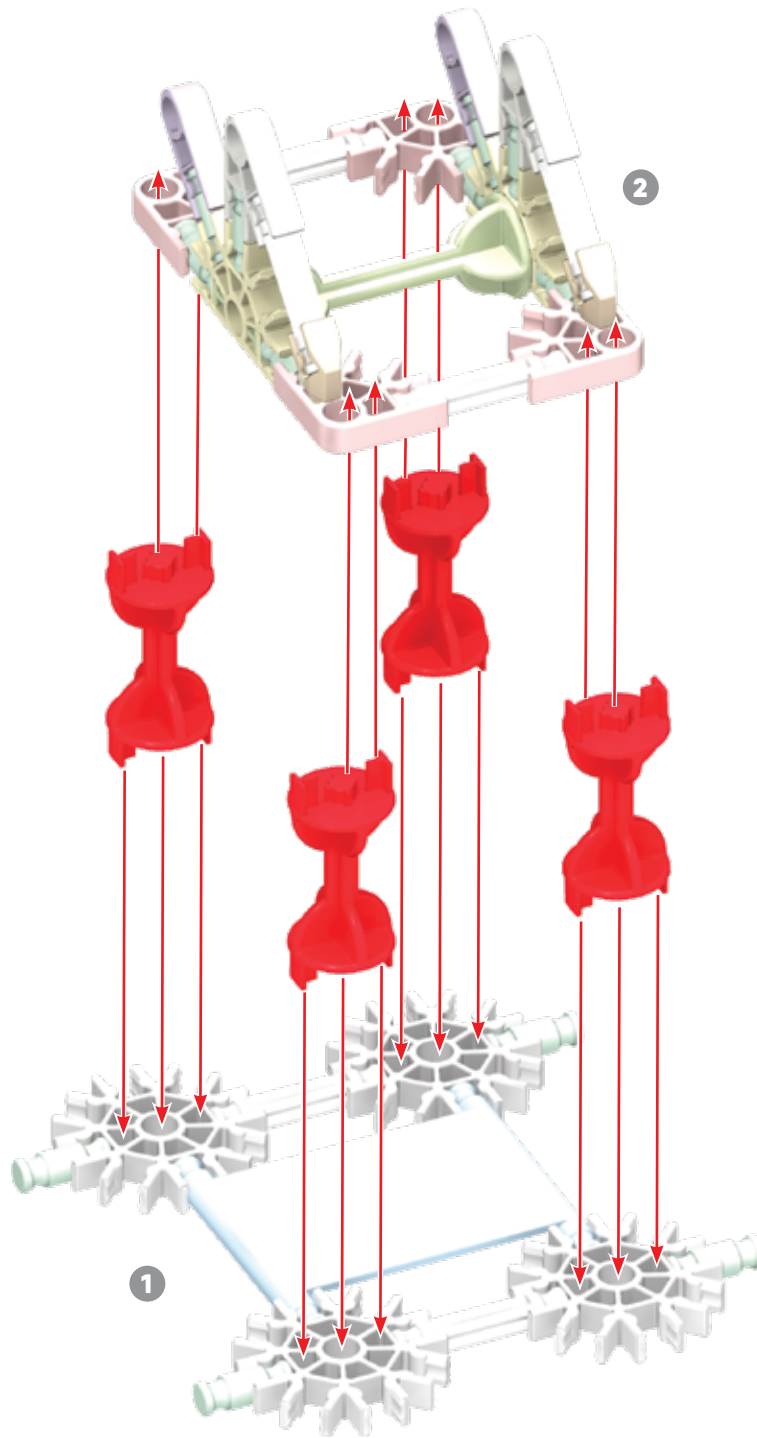



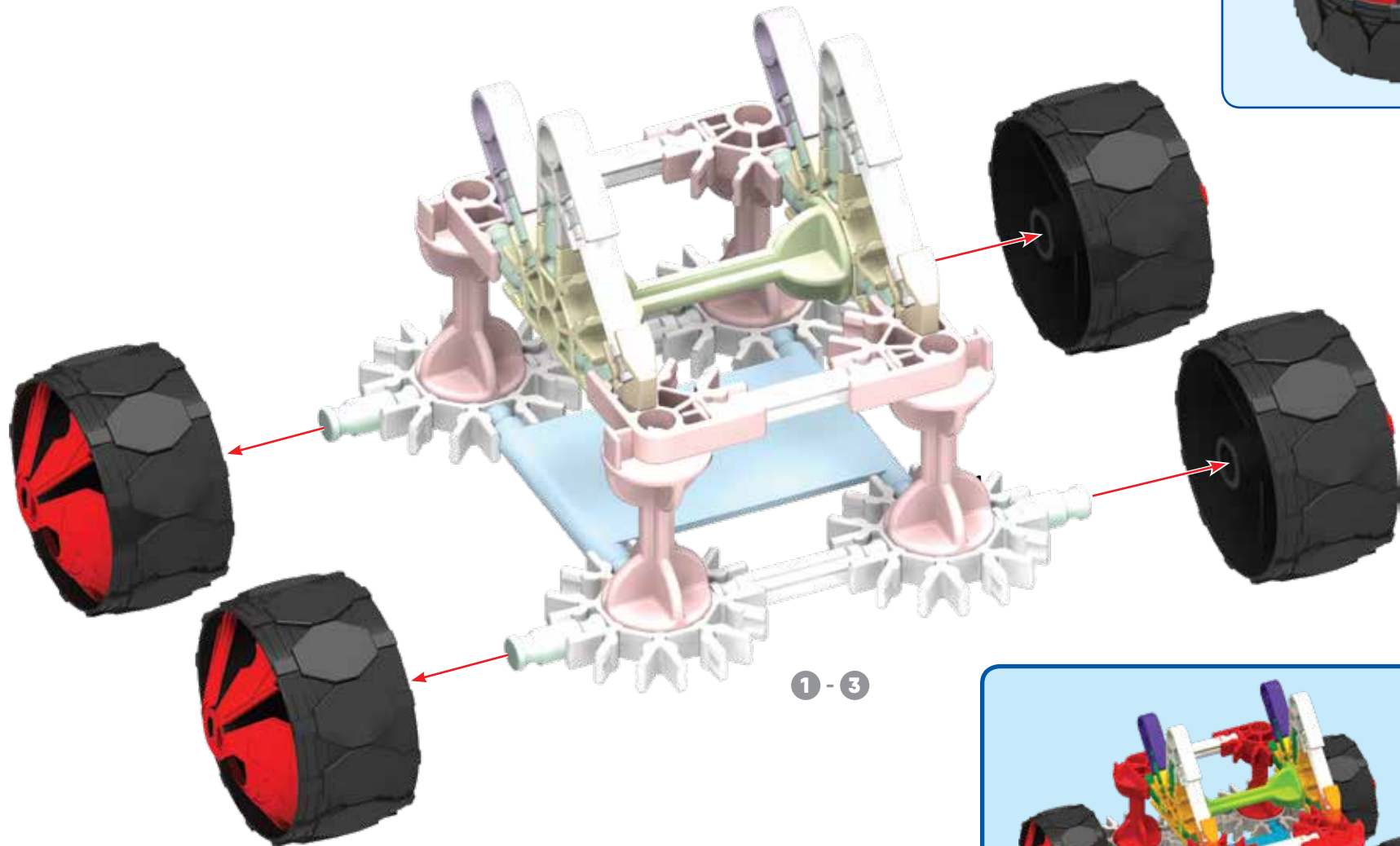



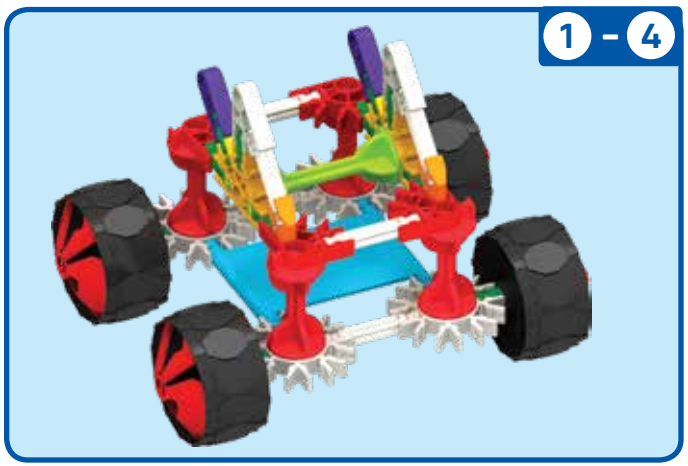

4



1 - 3



- 4  2 
- 8  1 
- 1  4 
- 2  4 

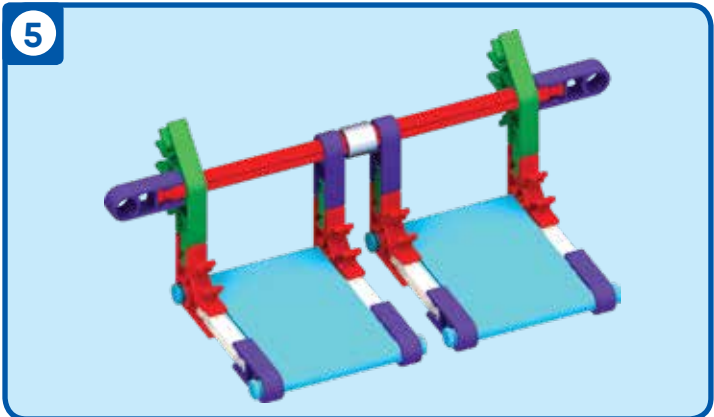
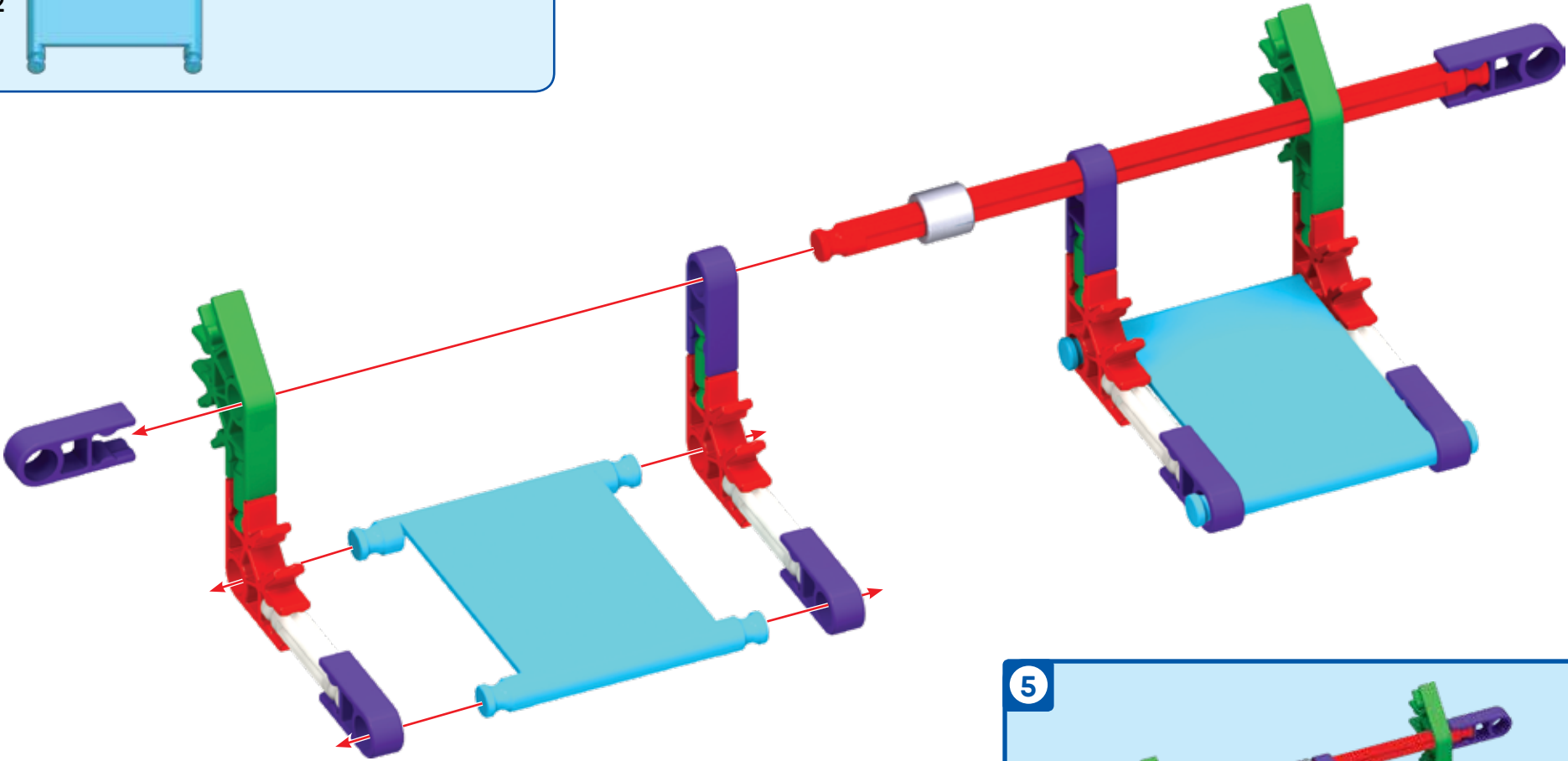

- 2 
- 4 
- 2 
- 4 
- 2 
- 2 
- 2 

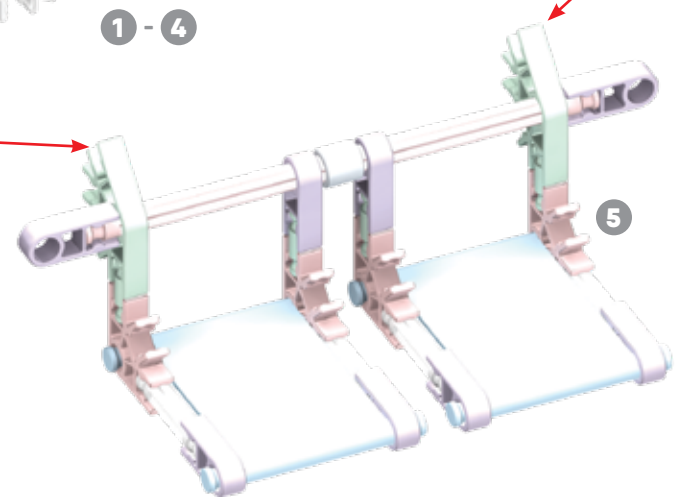
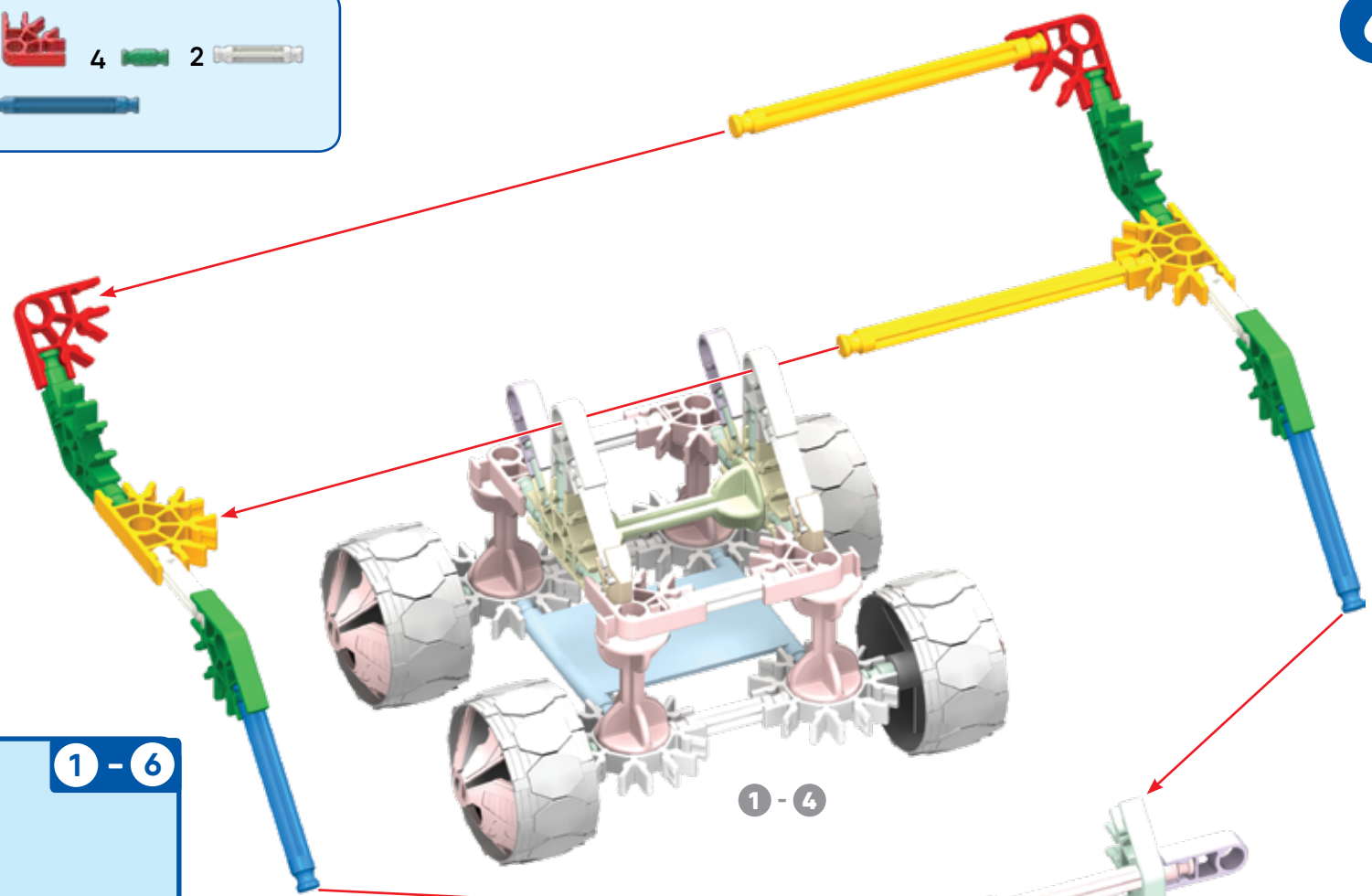

3



7

1 - 6

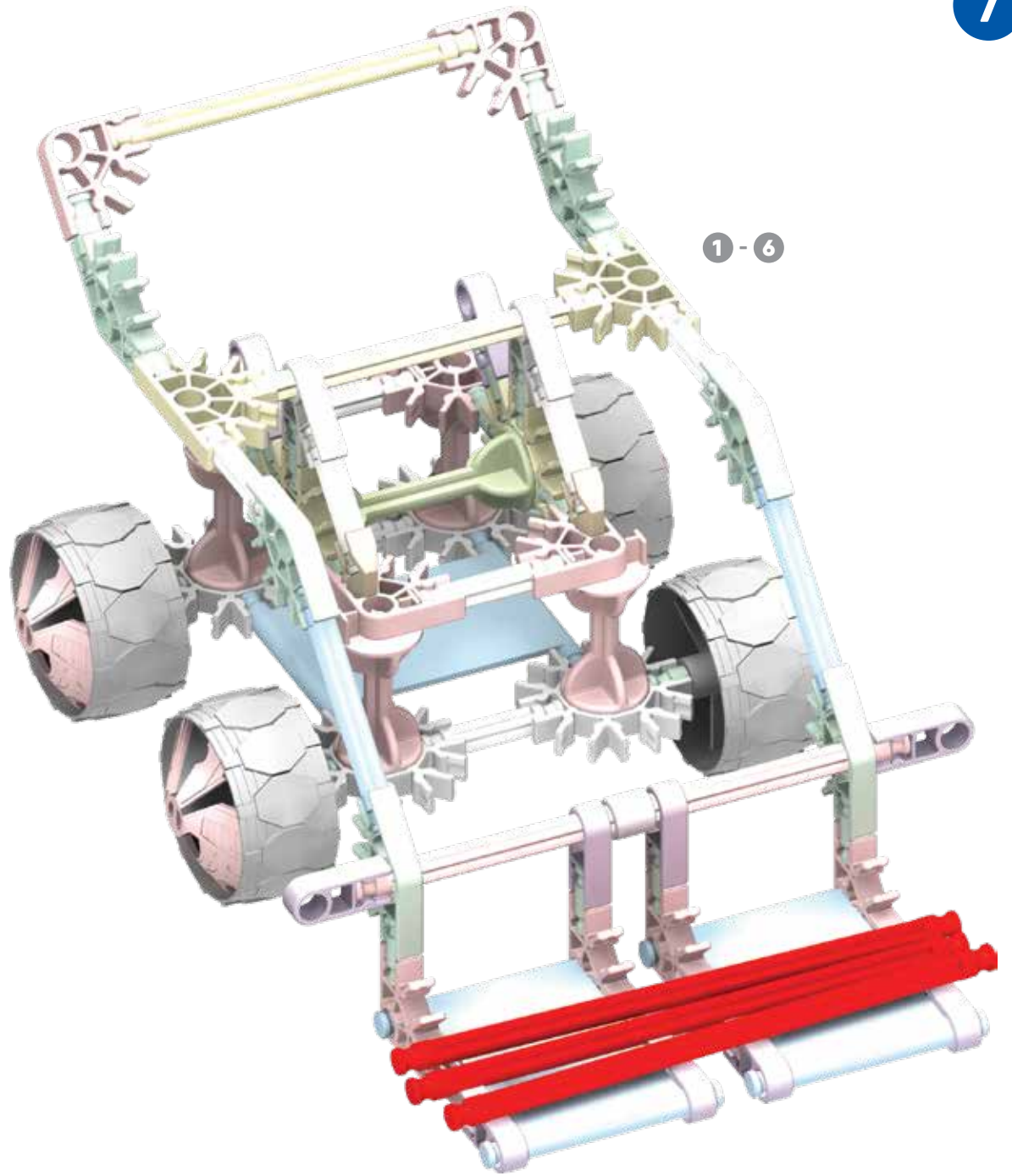

Construction Vehicle

1 - 7



1

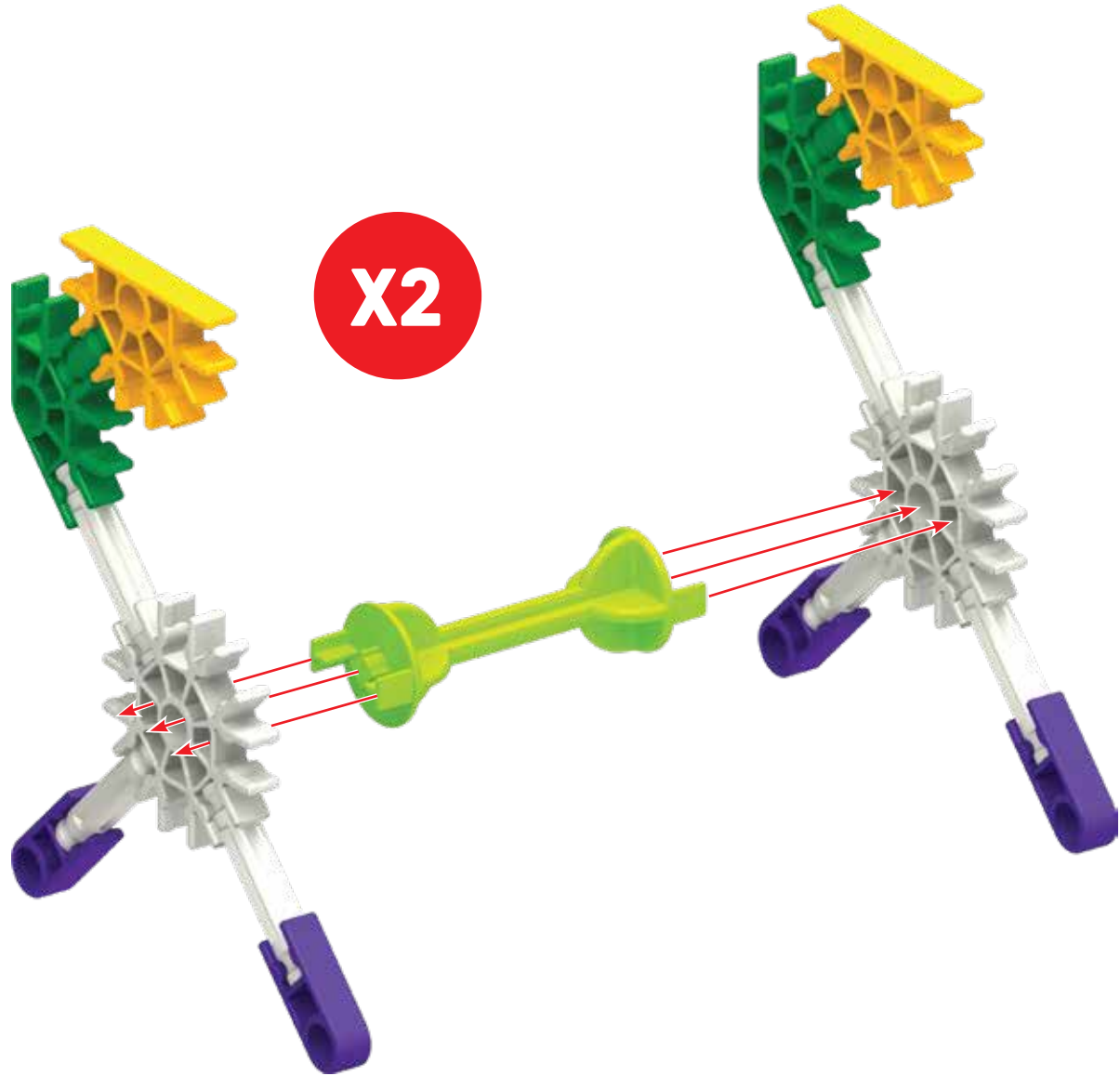

X2

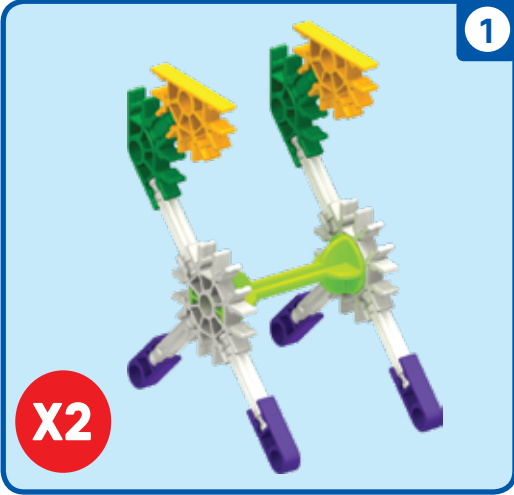

2

X2

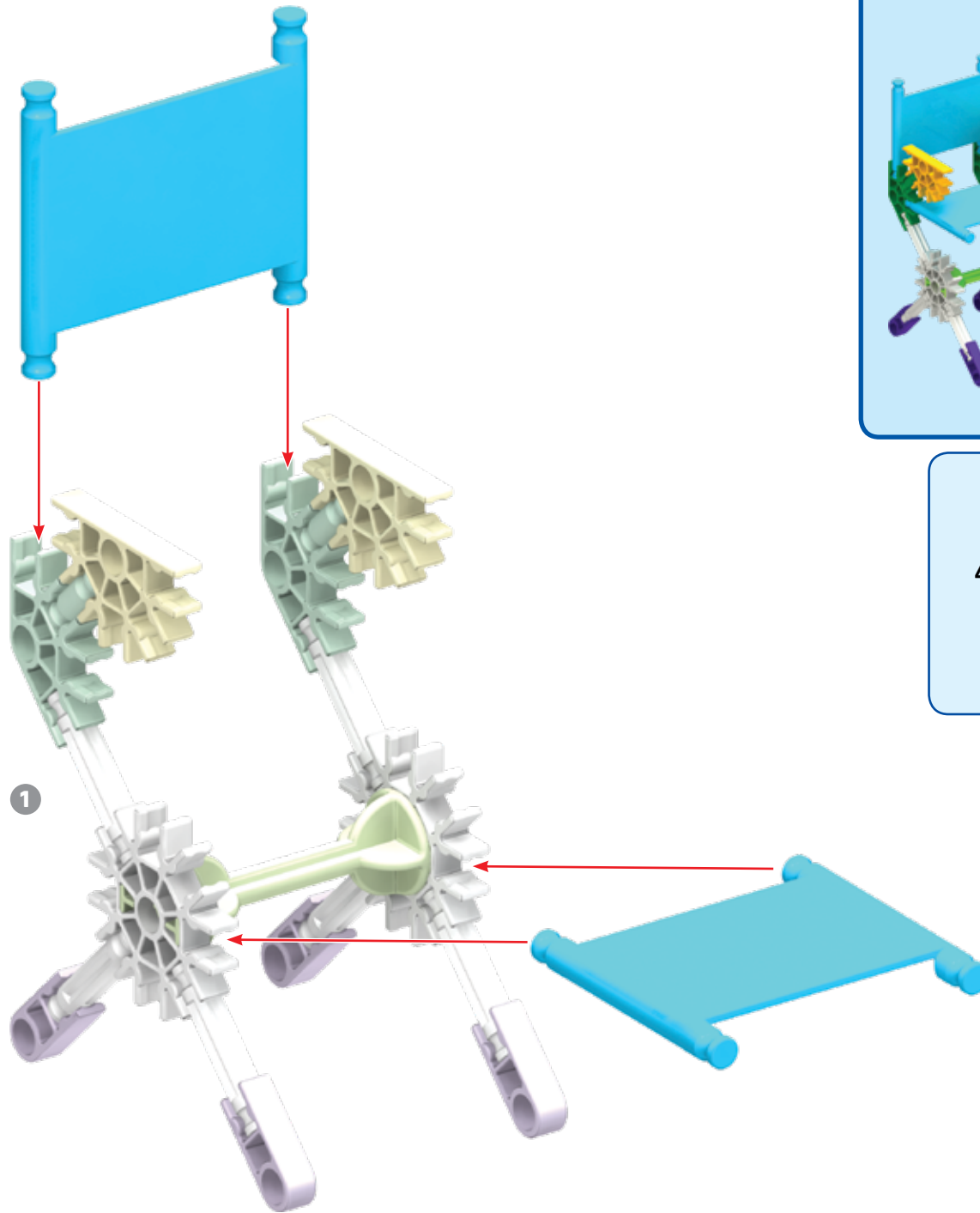

Director's
Chairs

1 - 2



4

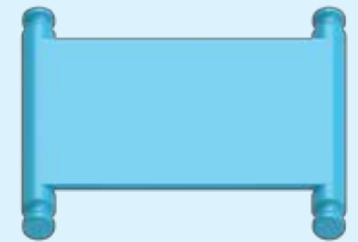

House

1

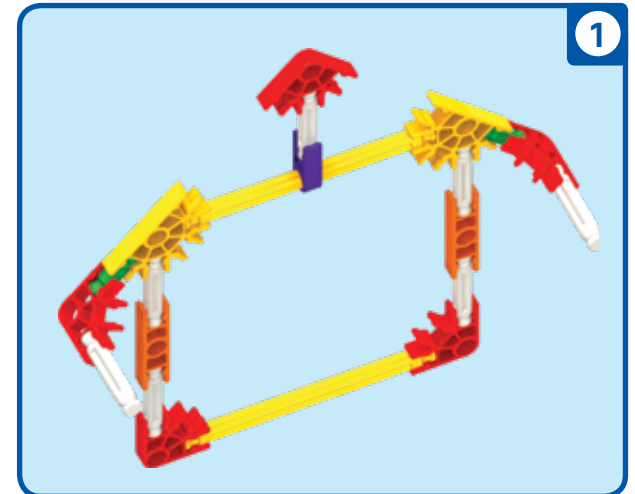
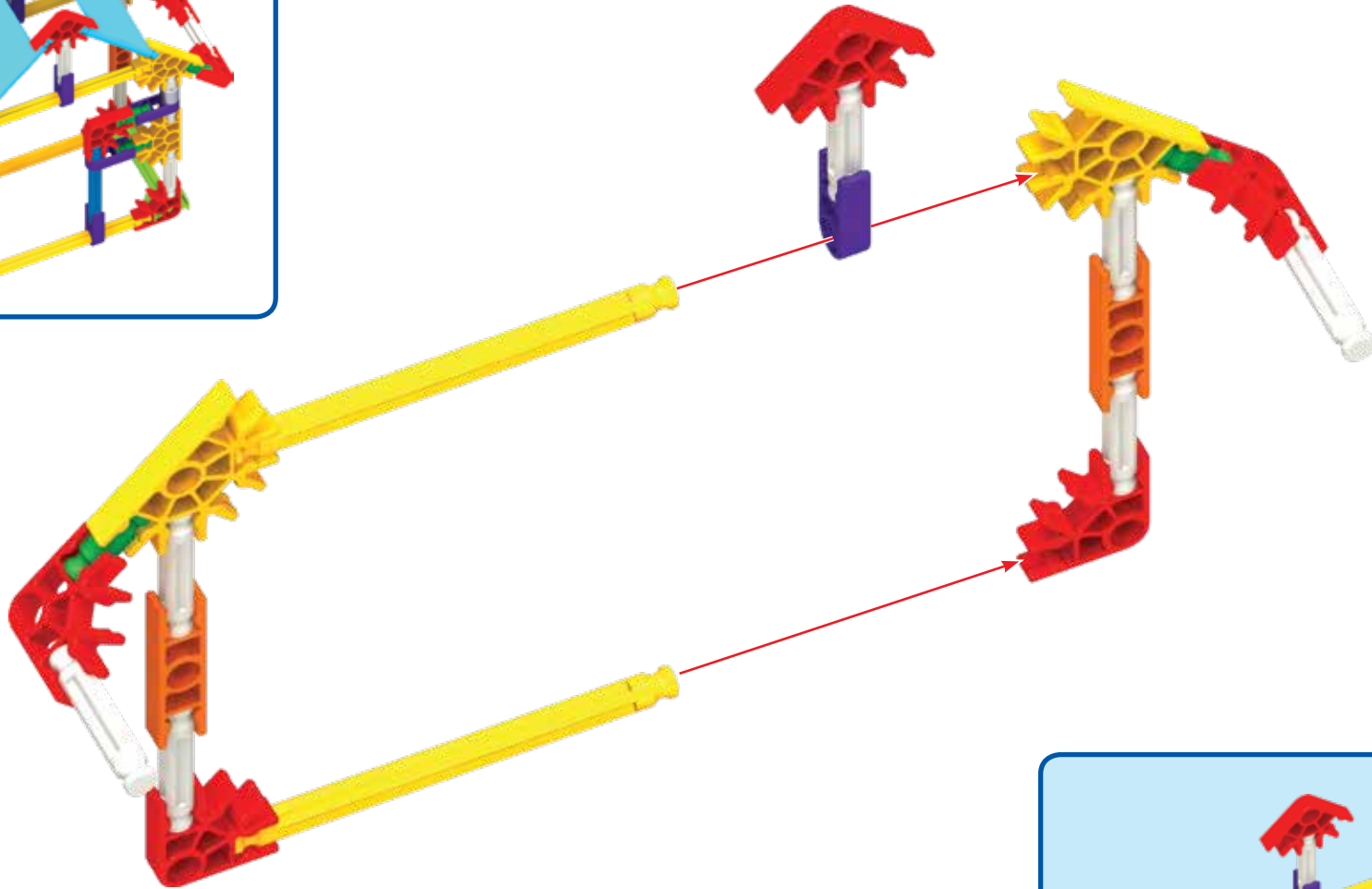

2

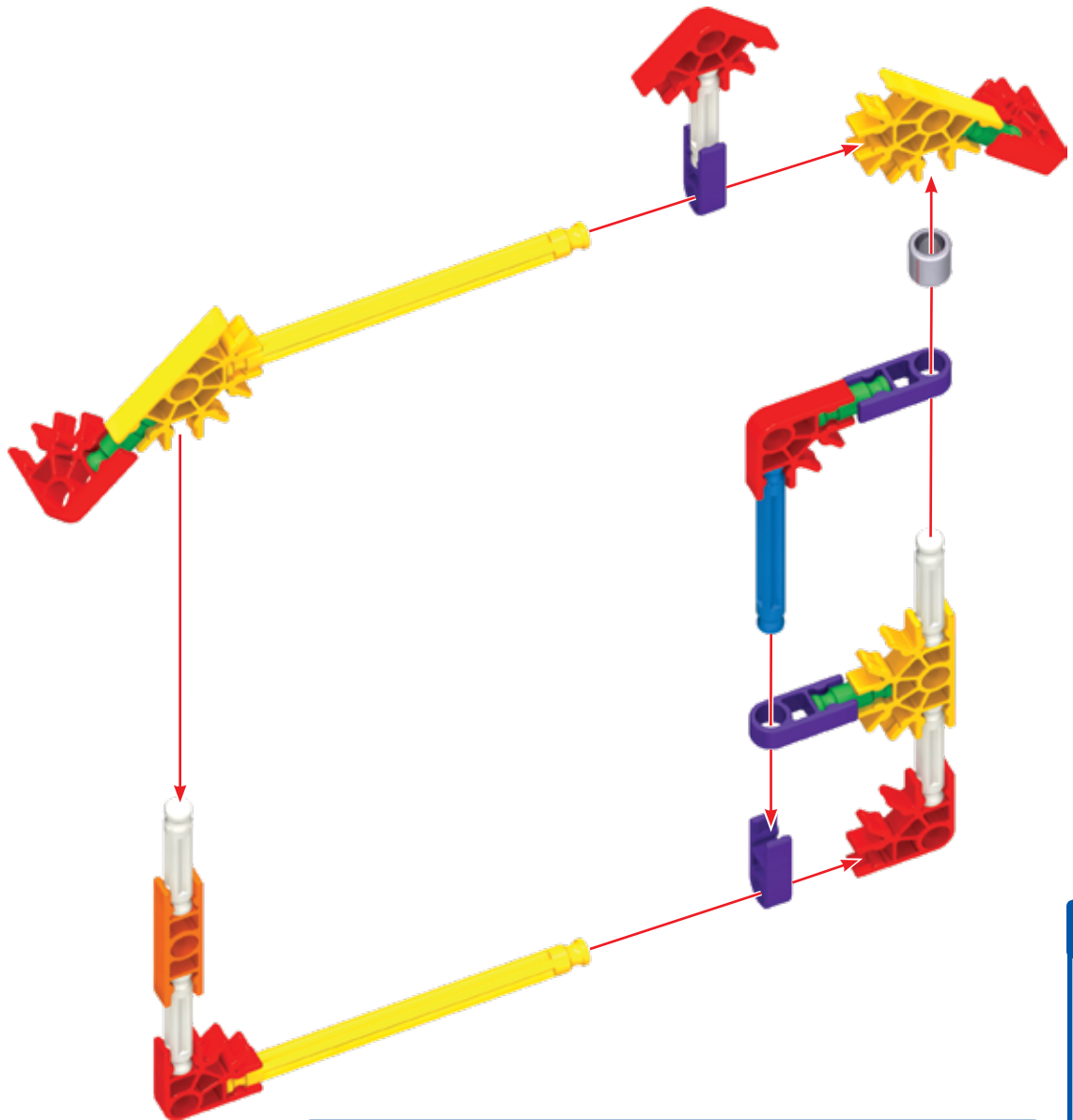

- | | | | | | | | |
|---|--|---|--|---|--|---|--|
| 3 | | 6 | | 1 | | 4 | |
| 4 | | 5 | | 1 | | 1 | |
| 2 | | | | | | | |

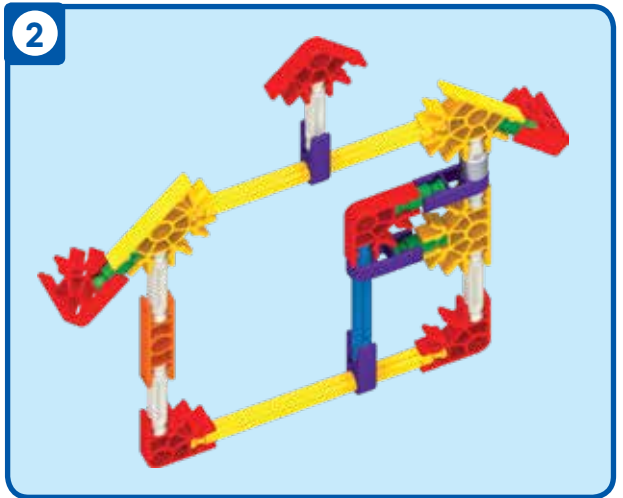

3

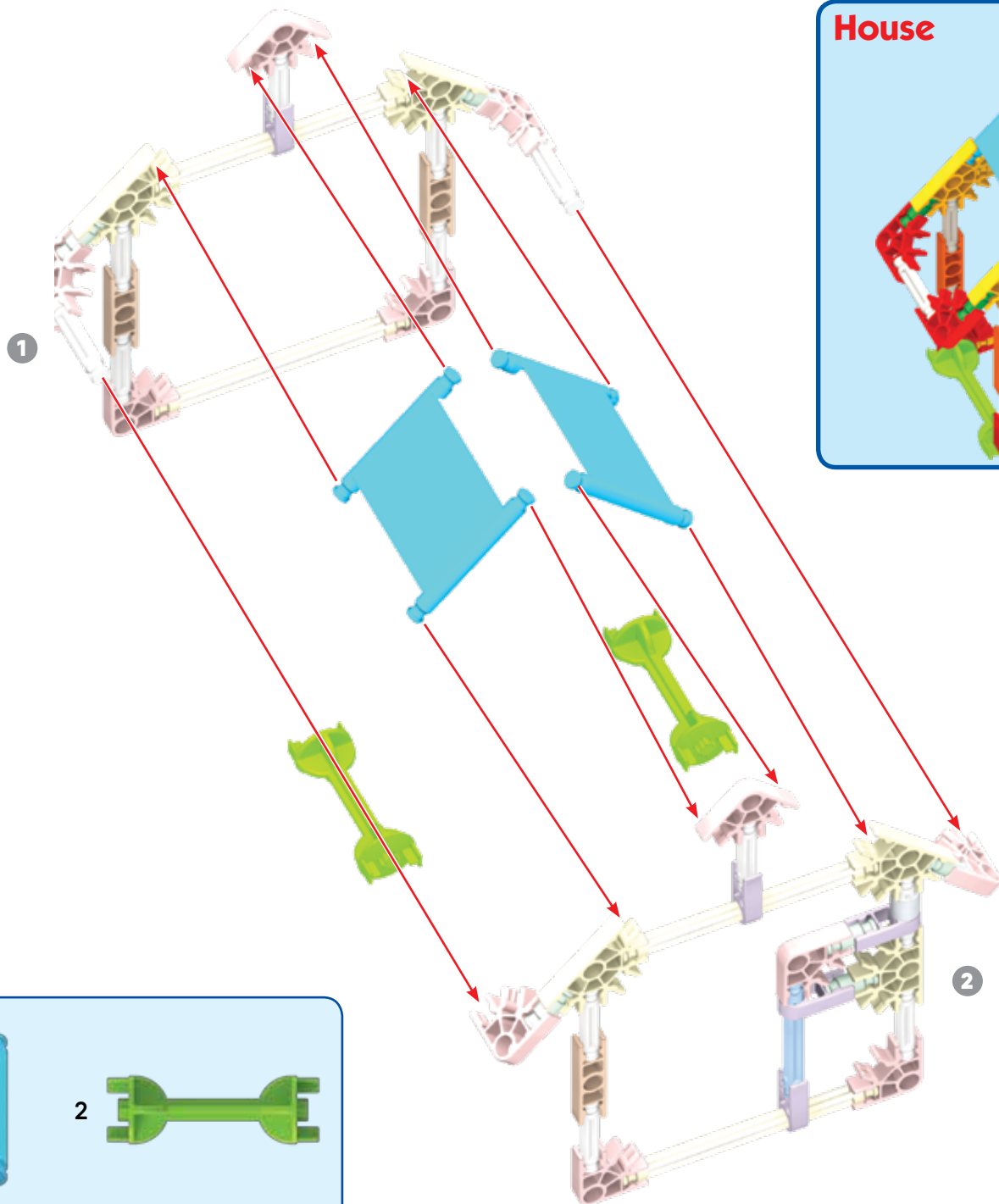

House

1 - 3

2



2



1

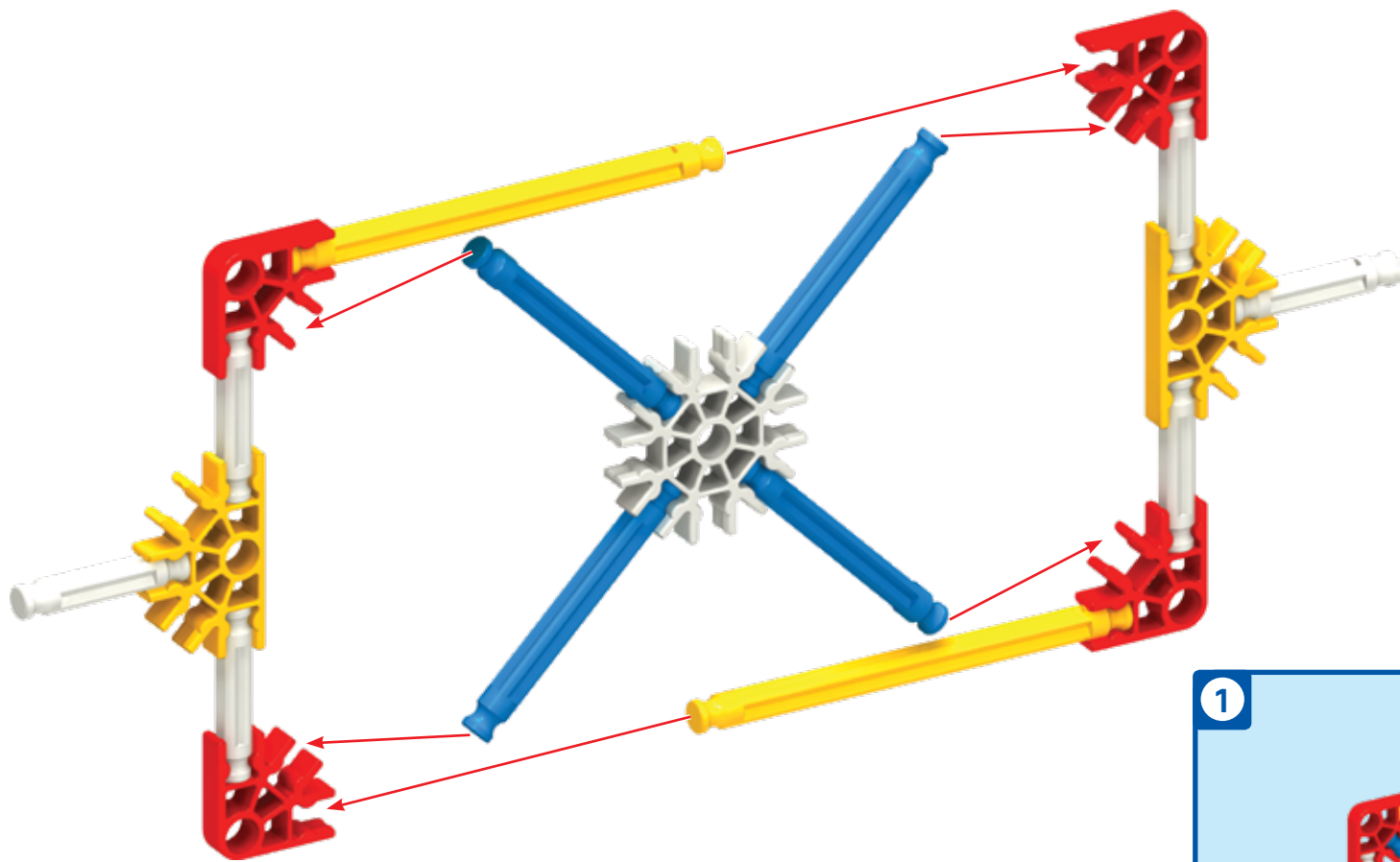

Drawing Board



- | | | | | | |
|---|--|---|--|---|--|
| 6 | | 4 | | 2 | |
| 1 | | 2 | | 4 | |

1

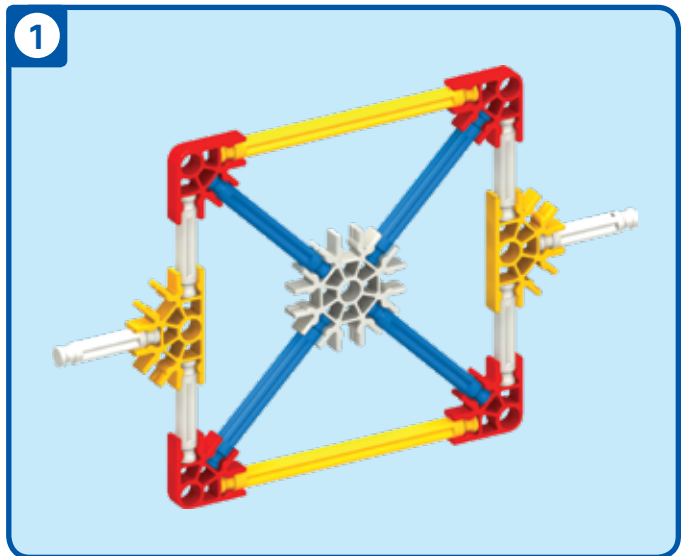

2

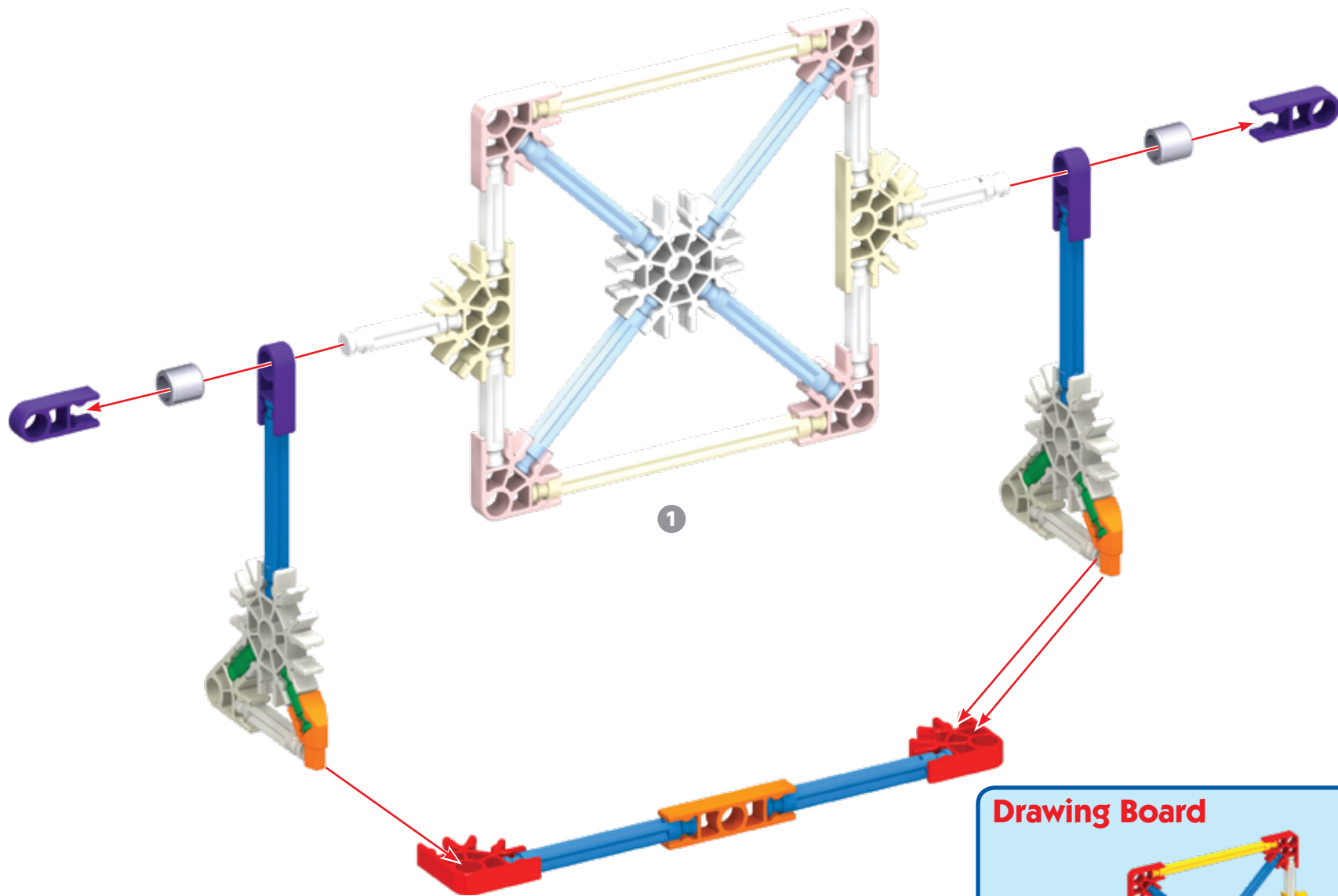

1

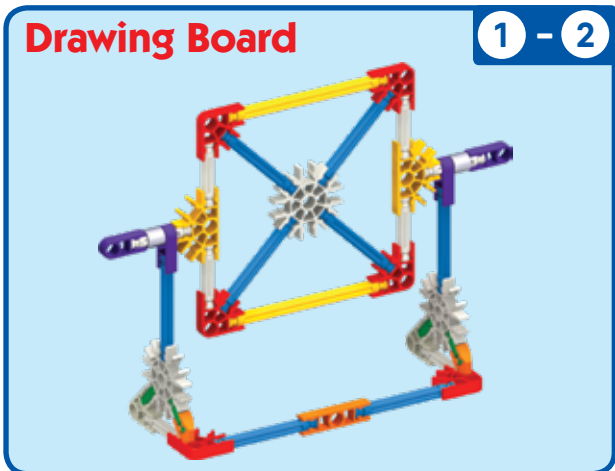

1

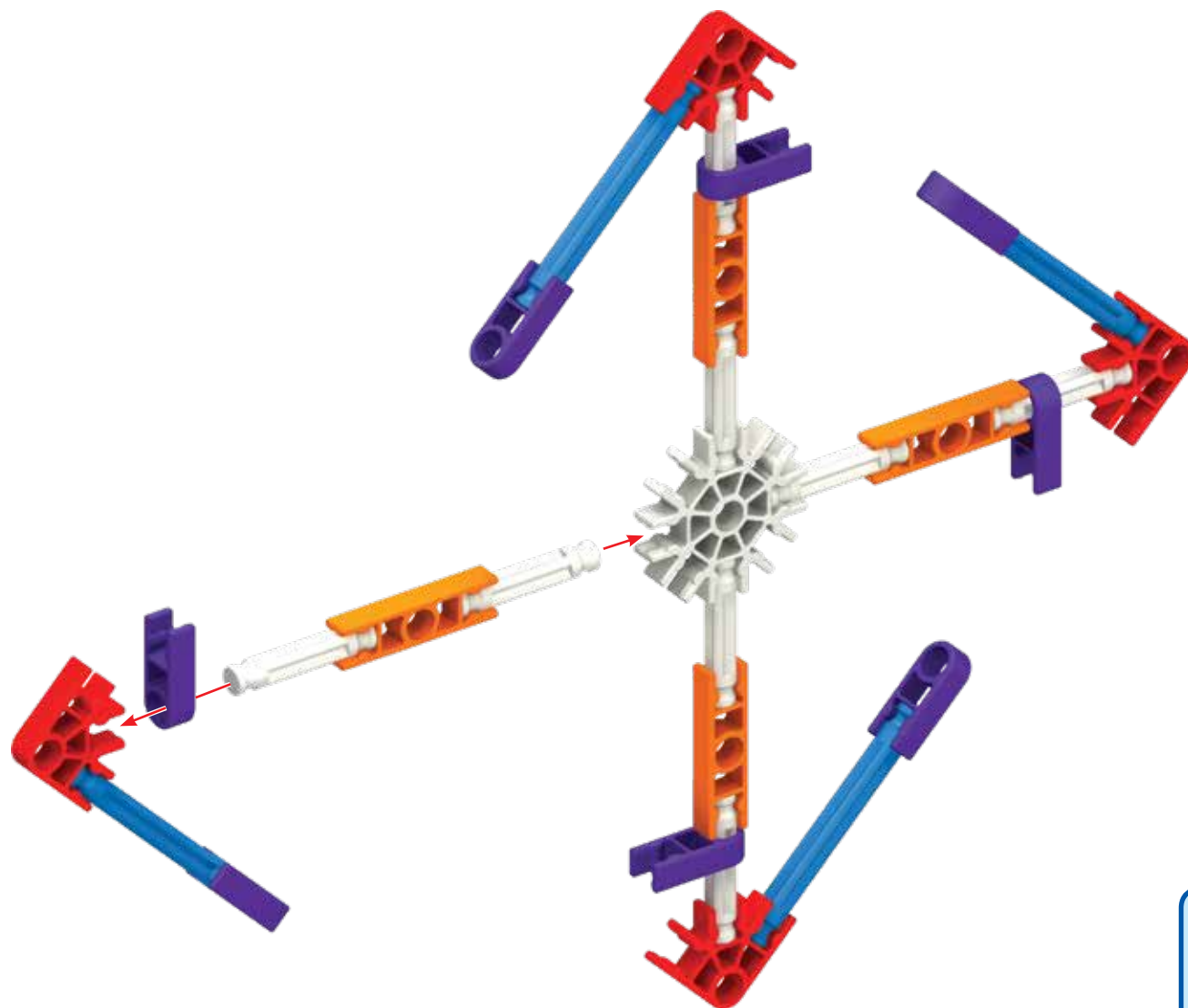

Ferris Wheel



- | | | | | | | | |
|---|--|---|--|---|--|---|--|
| 1 | | 4 | | 4 | | 8 | |
| 8 | | 4 | | | | | |

1

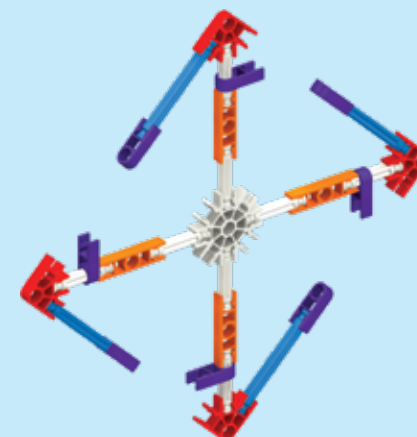

2

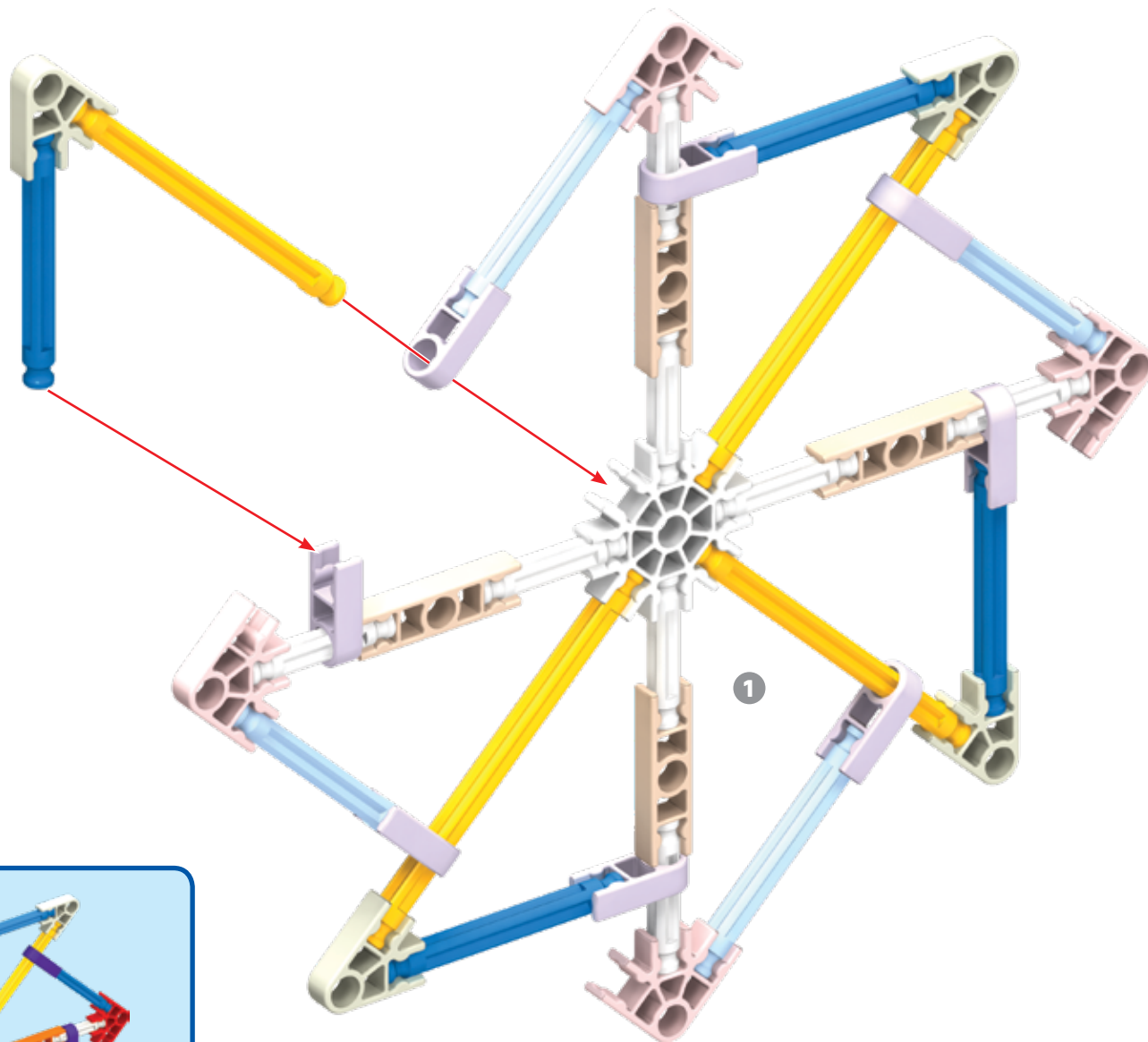

1 - 2



4



4



4

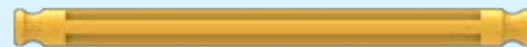

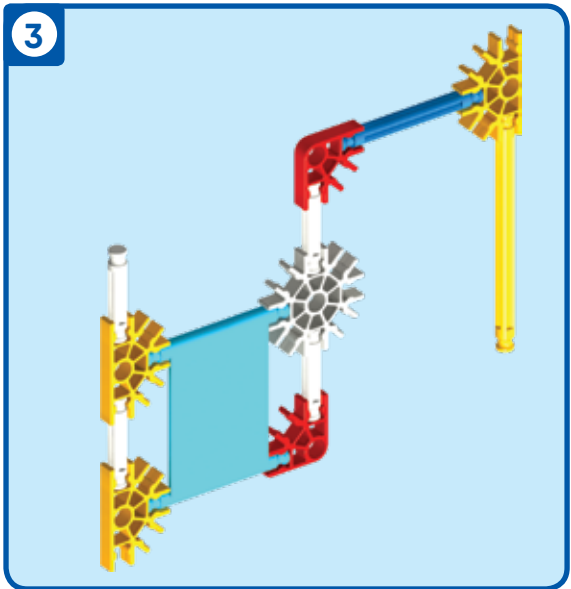
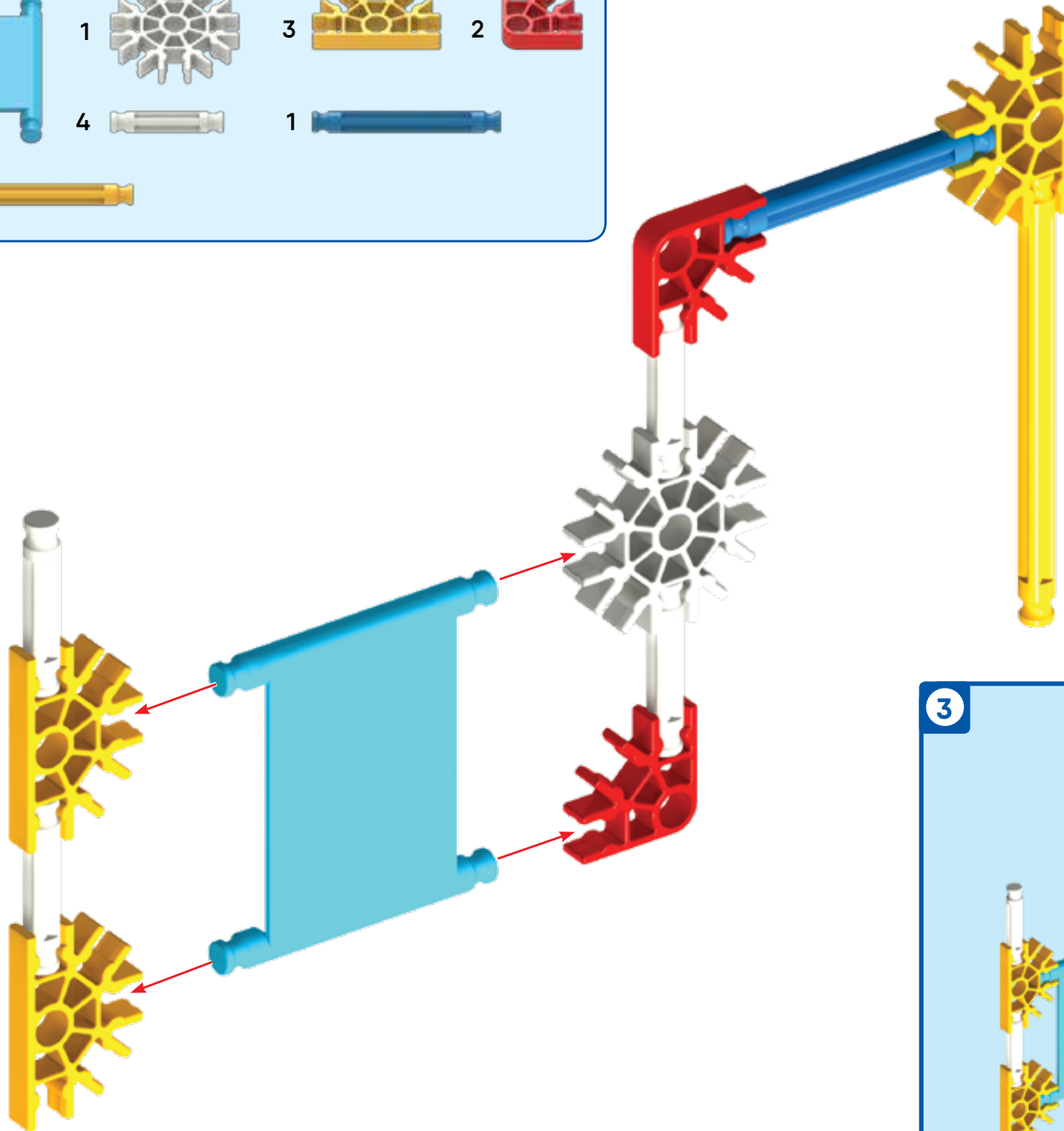

4

X2

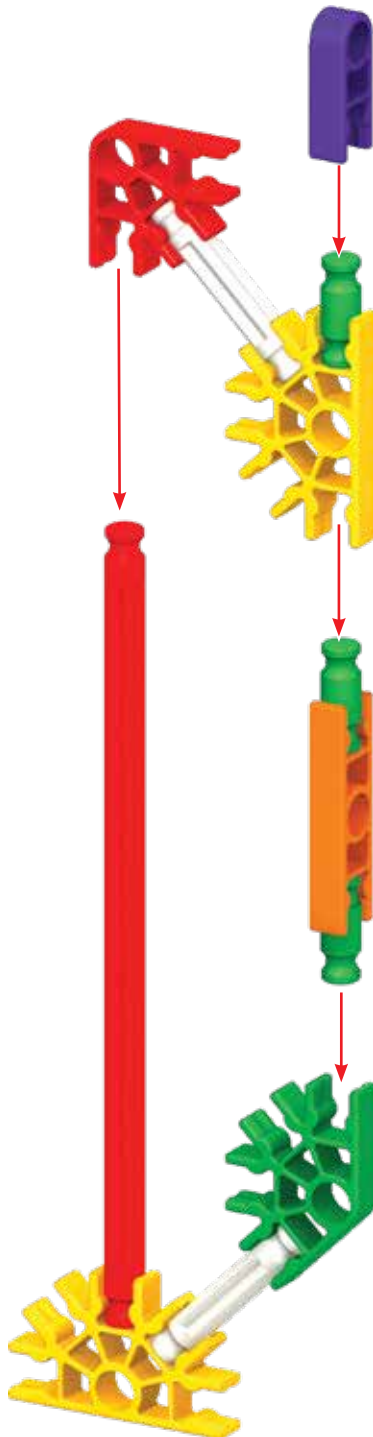

4



X2

5

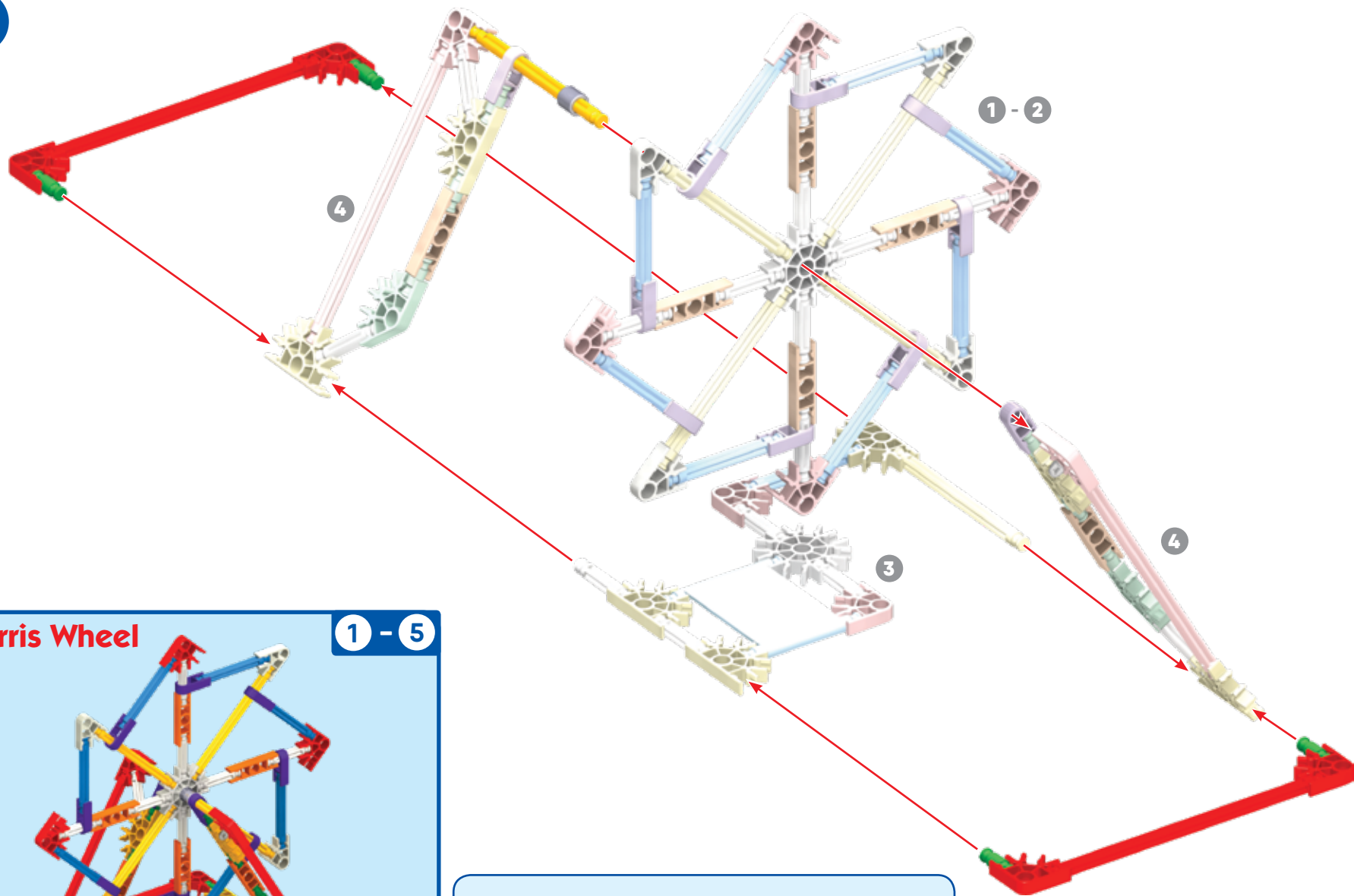

Ferris Wheel

1 - 5



- | | | | |
|---|--|---|--|
| 4 | | 1 | |
| 4 | | 1 | |
| 2 | | | |

1

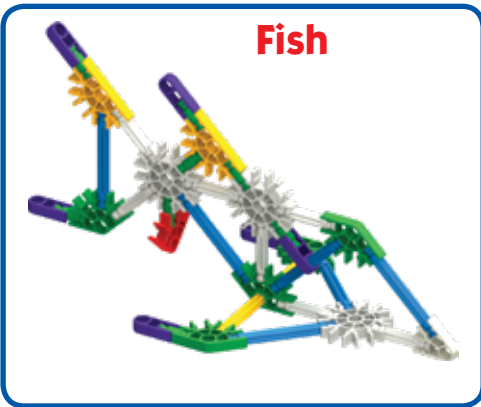
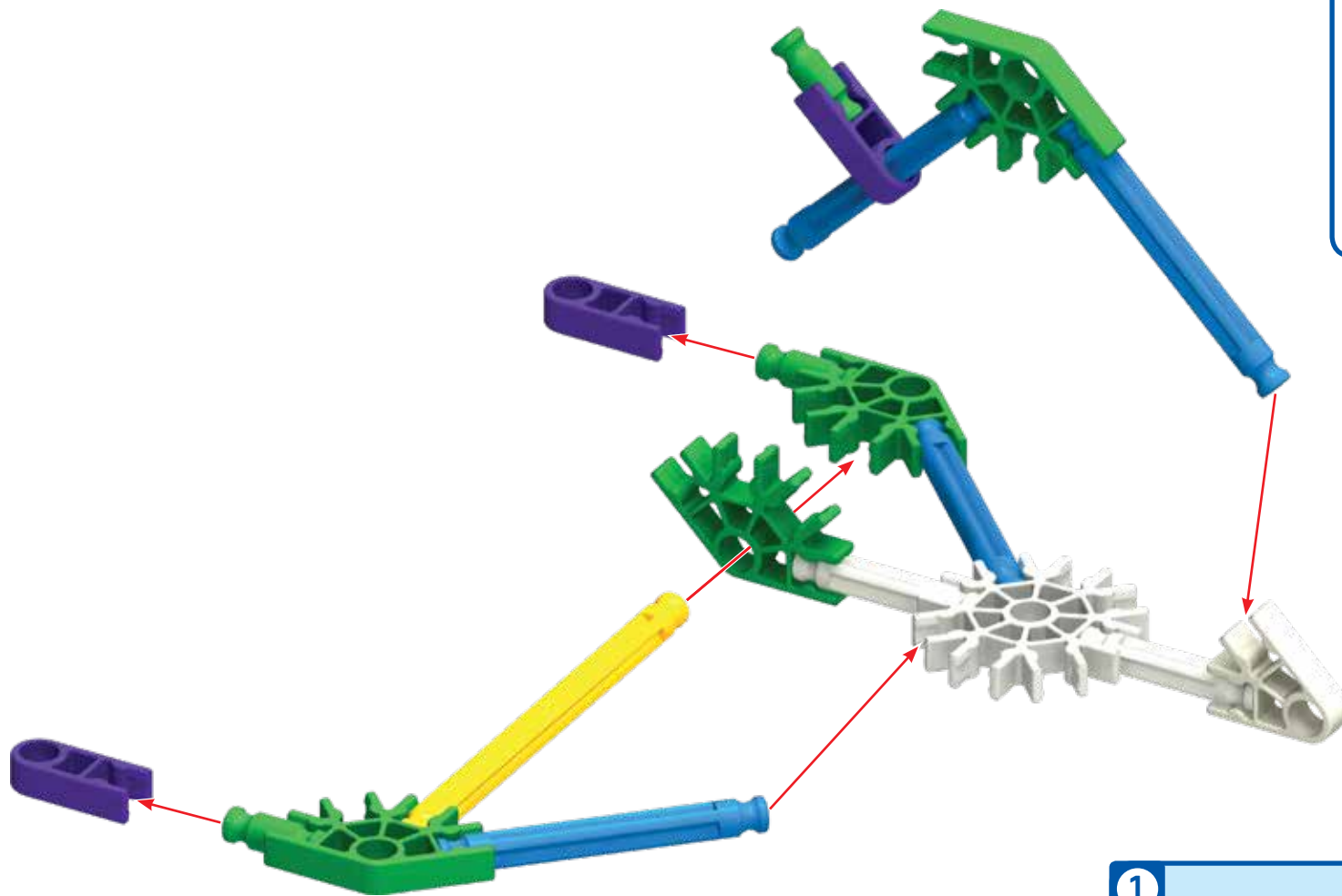

- | | | | | | | | | | |
|---|--|---|--|---|--|---|--|---|--|
| 1 | | 4 | | 1 | | 3 | | 3 | |
| 2 | | 4 | | 1 | | | | | |

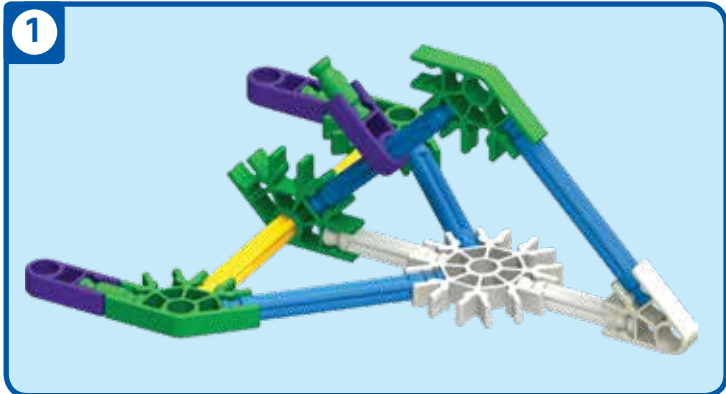

2

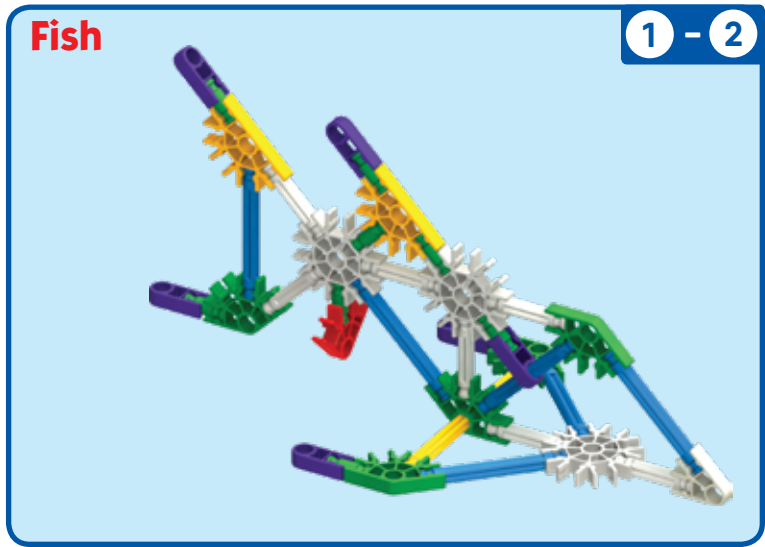
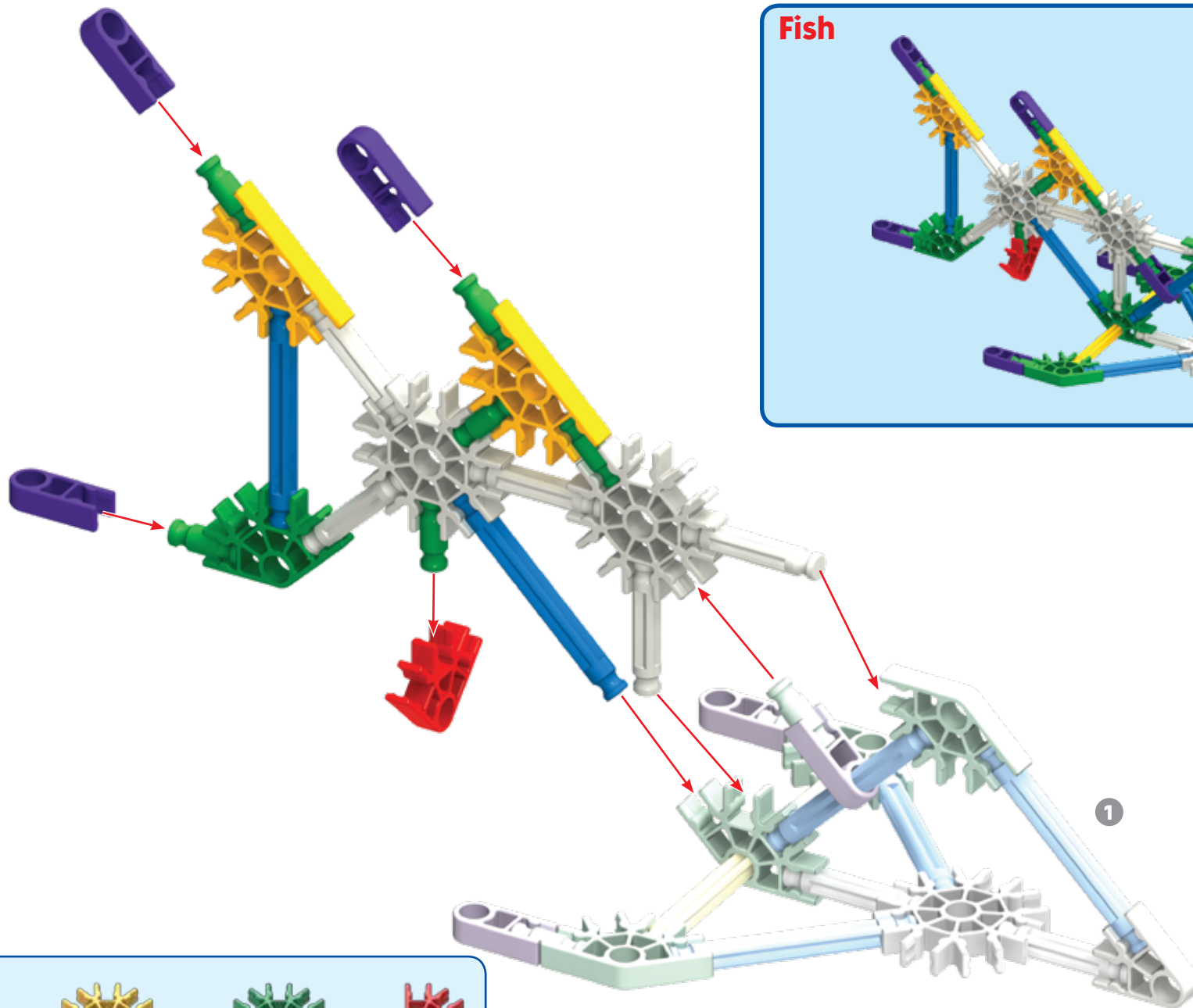

- | | | | | | | | |
|---|--|---|--|---|--|---|--|
| 2 | | 2 | | 1 | | 1 | |
| 3 | | 6 | | 5 | | 2 | |

1

Horse

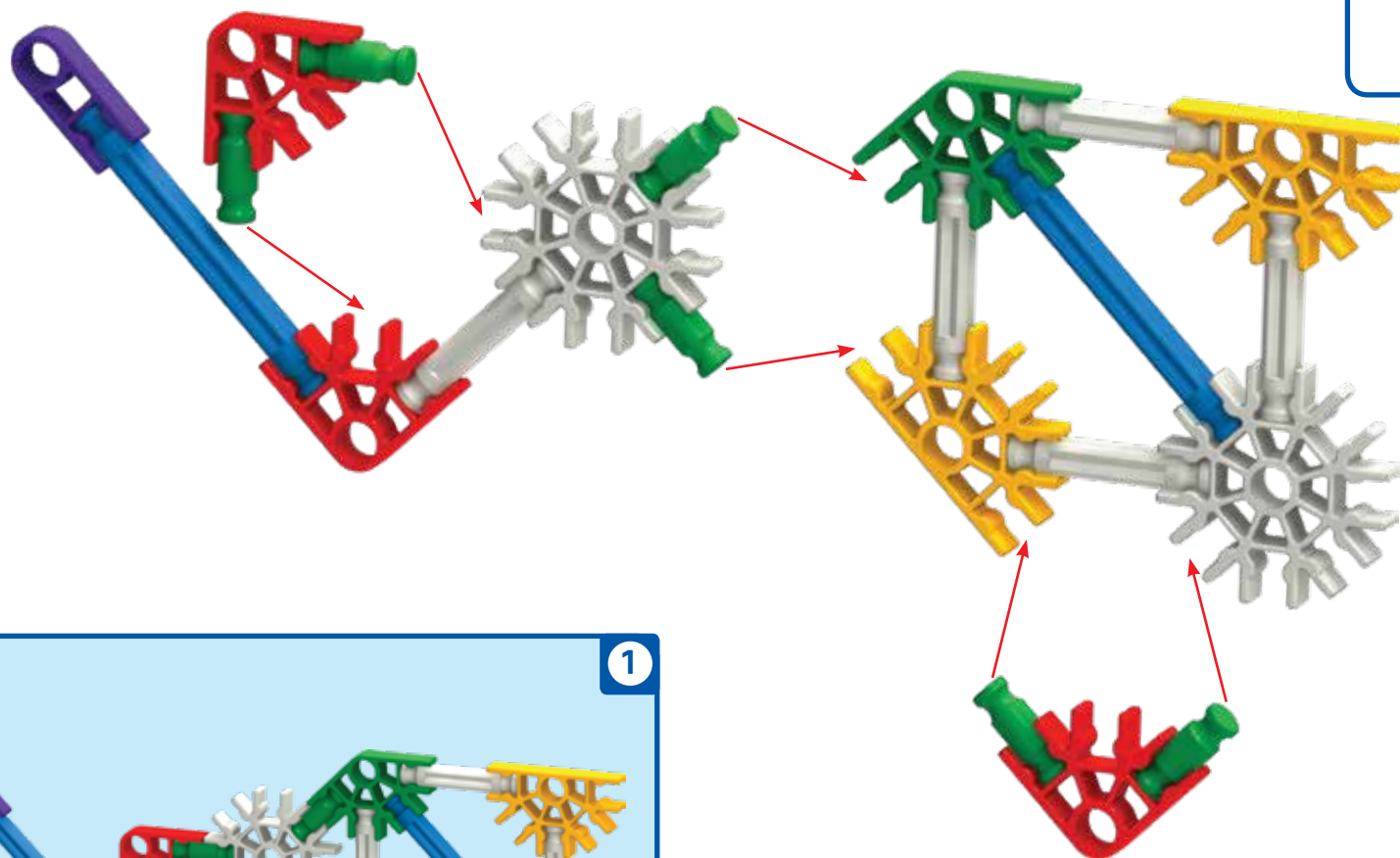

1

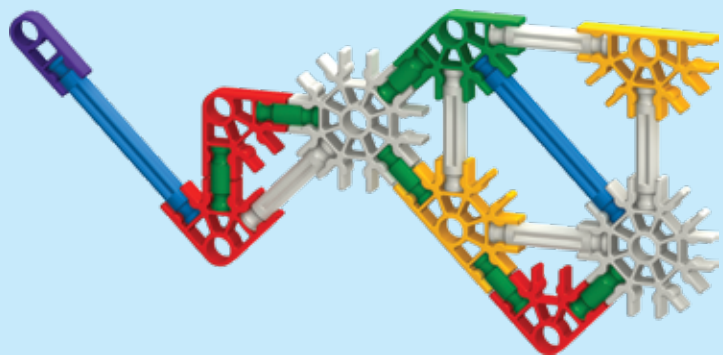

- | | | | | | | | |
|---|--|---|--|---|--|---|--|
| 2 | | 2 | | 1 | | 3 | |
| 1 | | 6 | | 5 | | 2 | |

2

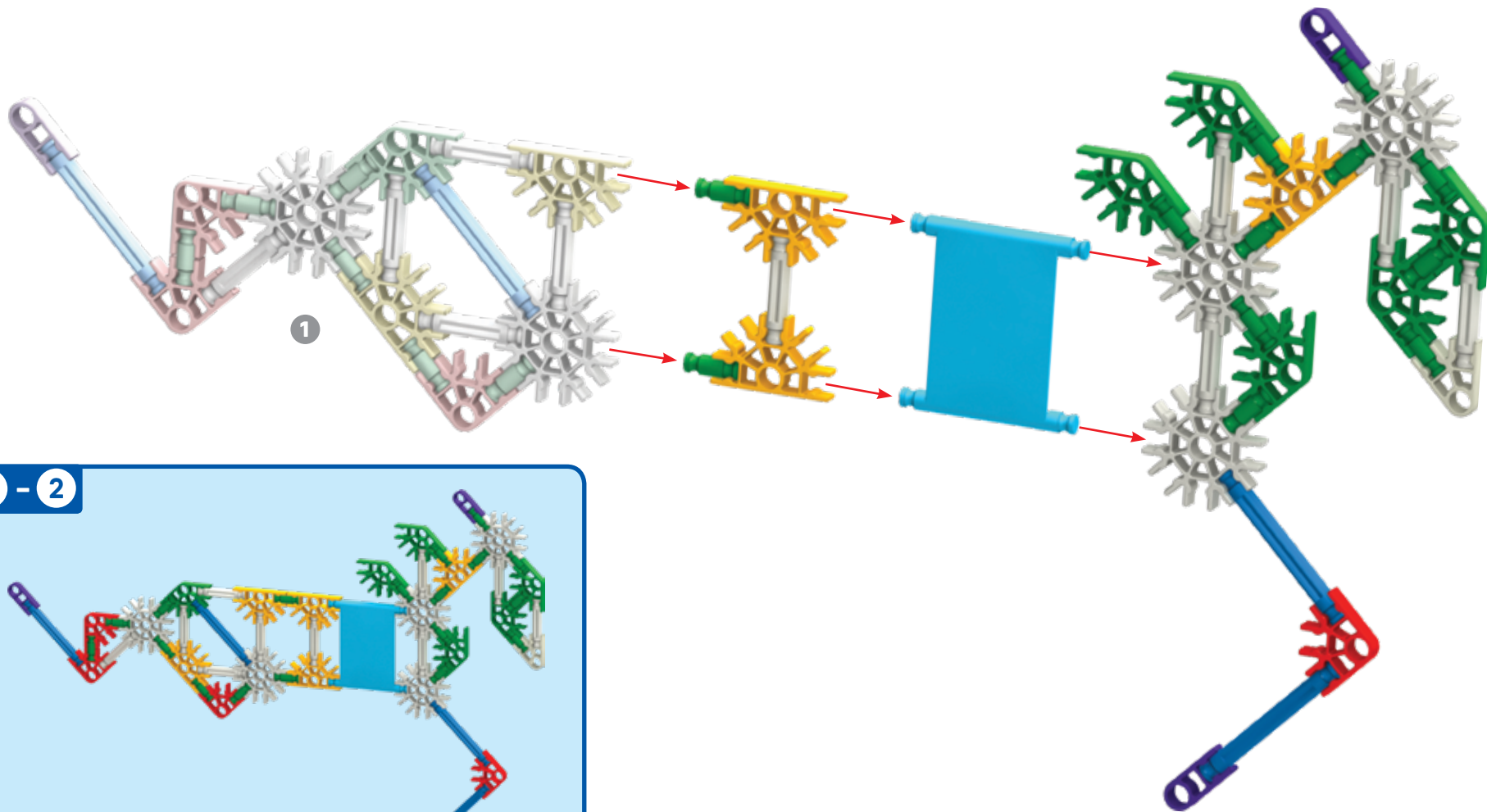
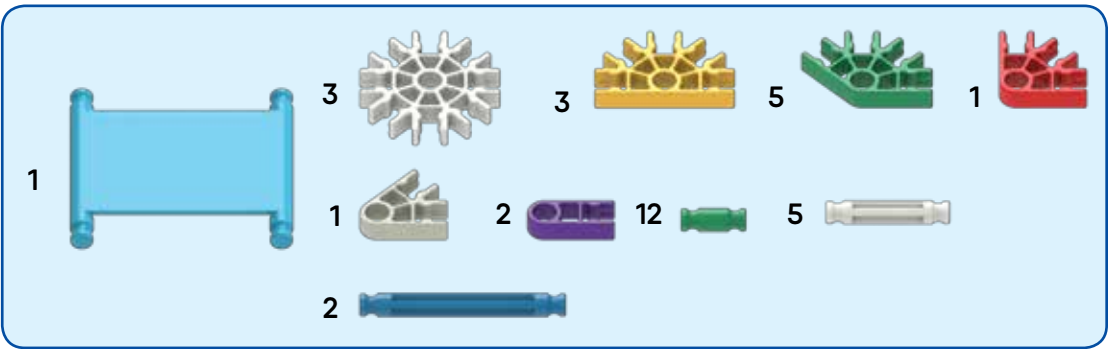

1 - 2

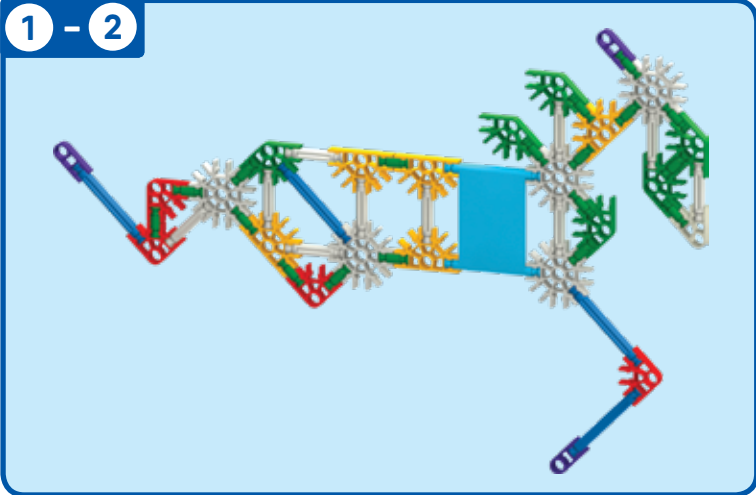

3

- 1  2  1  1 
- 2  2  1  3 
- 3  5 

1 - 3



1 - 2

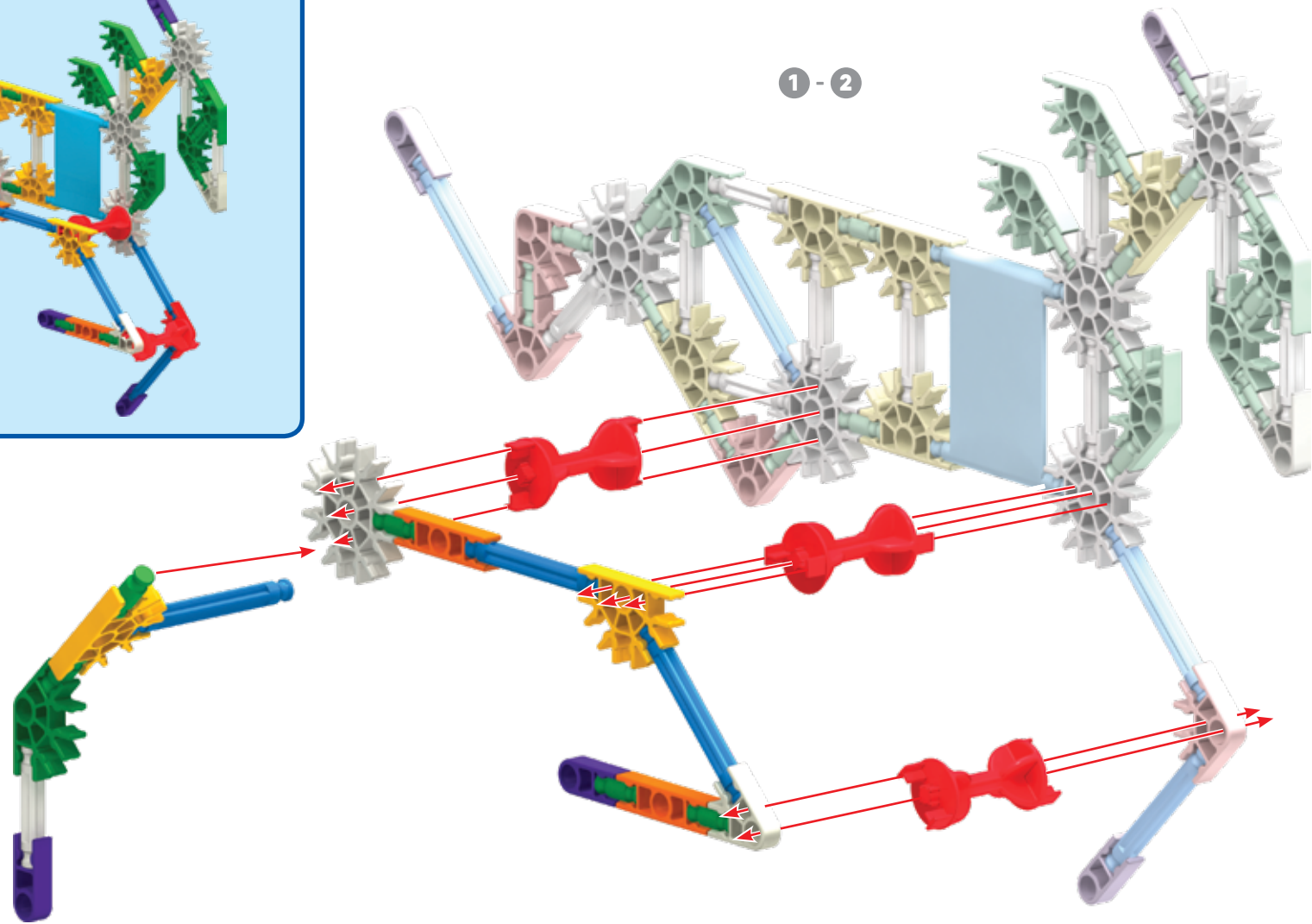

4

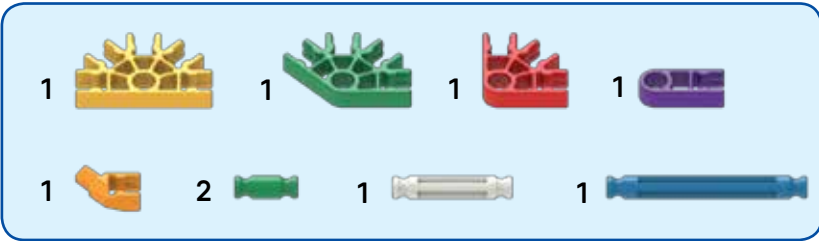

Horse

1 - 4

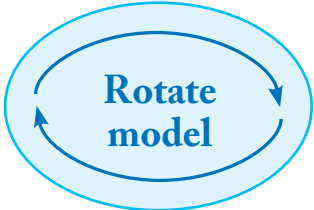
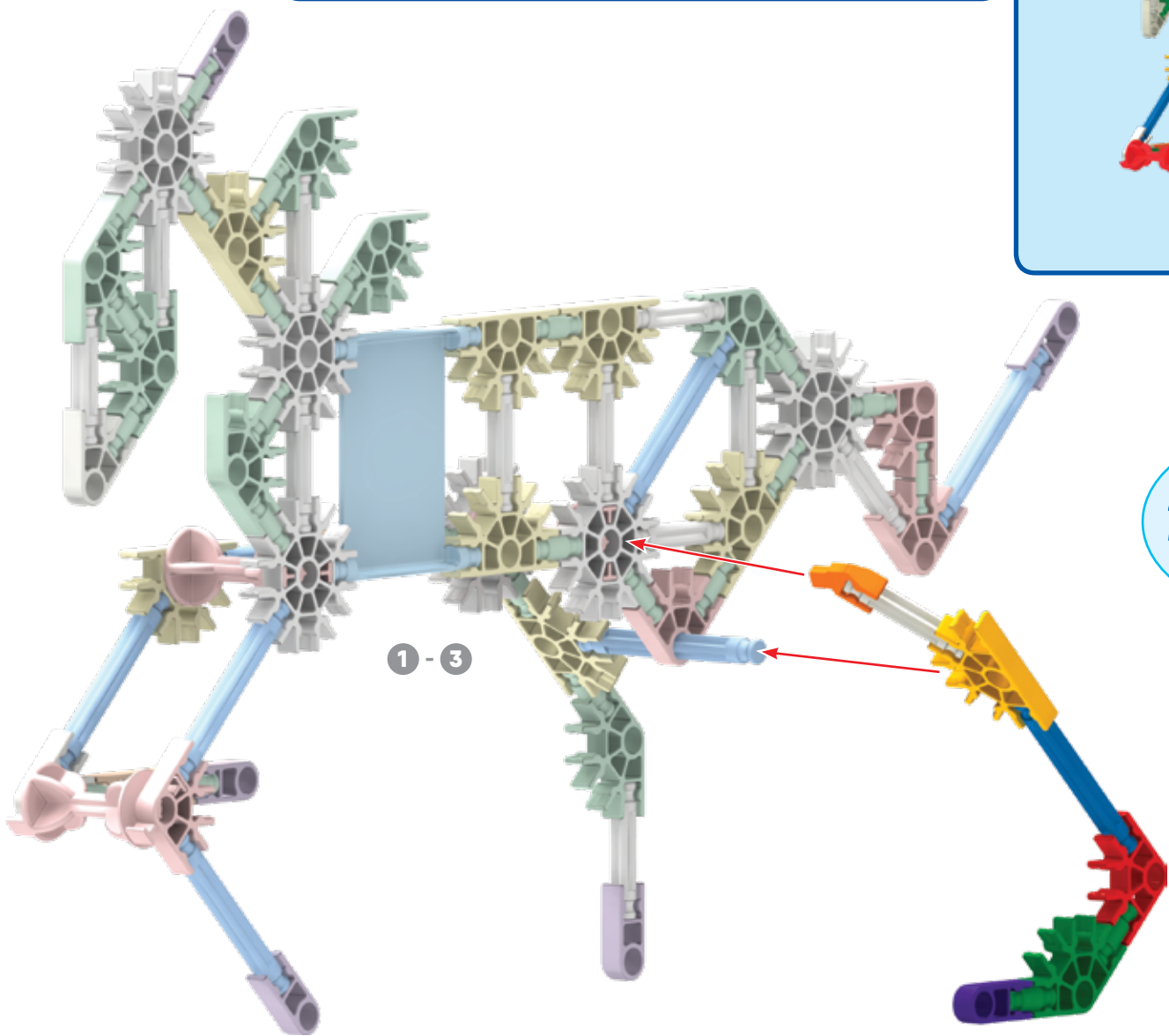
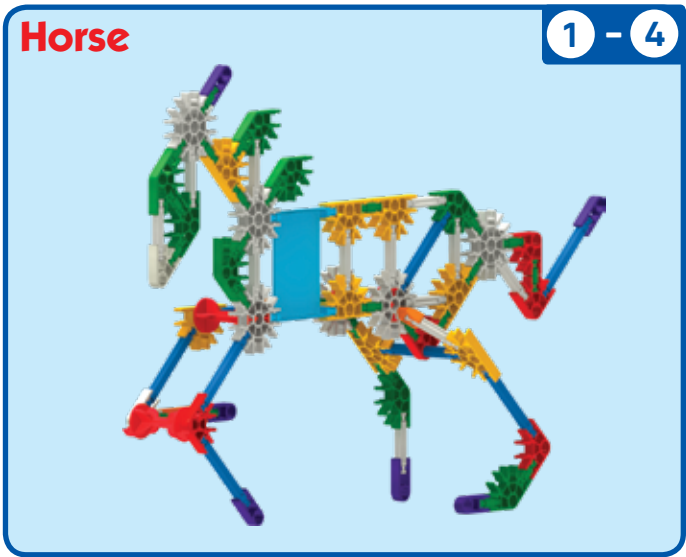

1

Jet

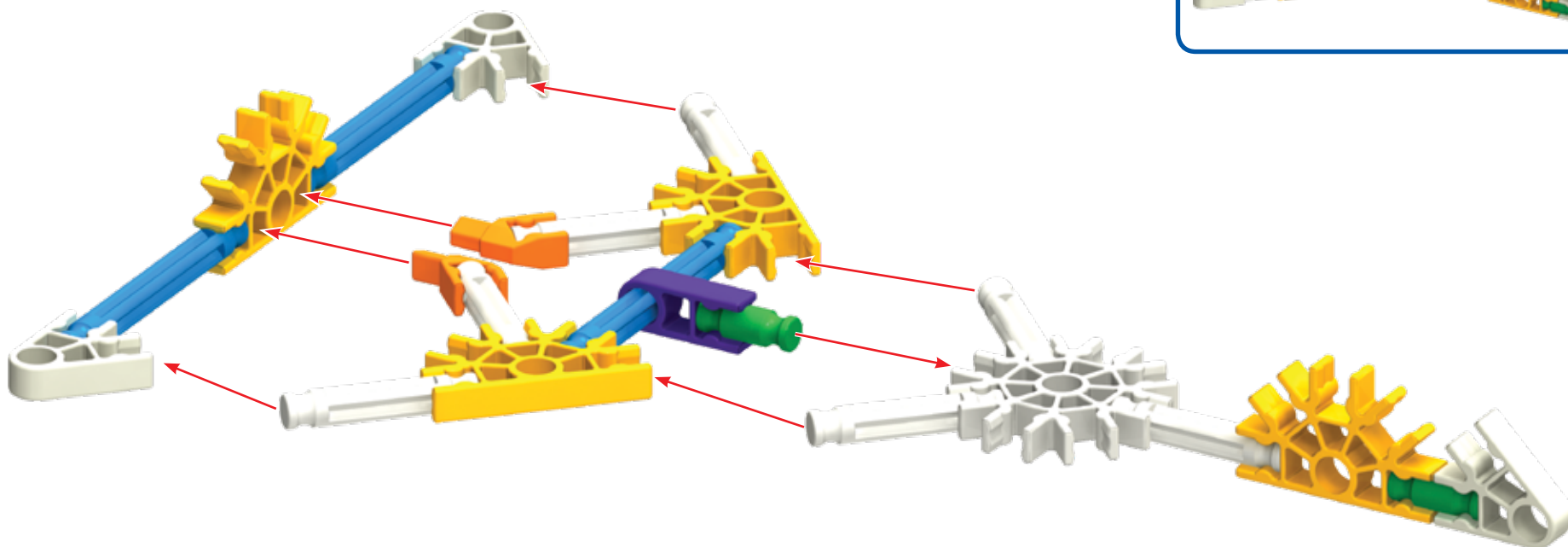

1

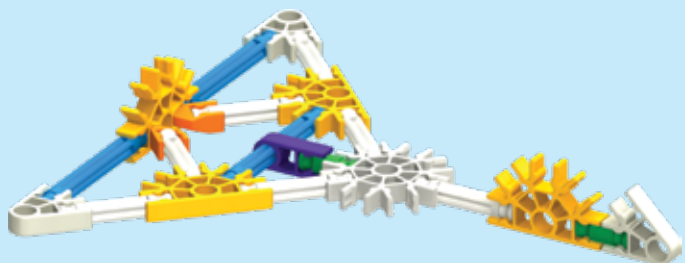

1

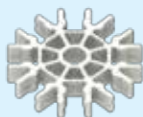

4



3



1



2



2



7



3



2

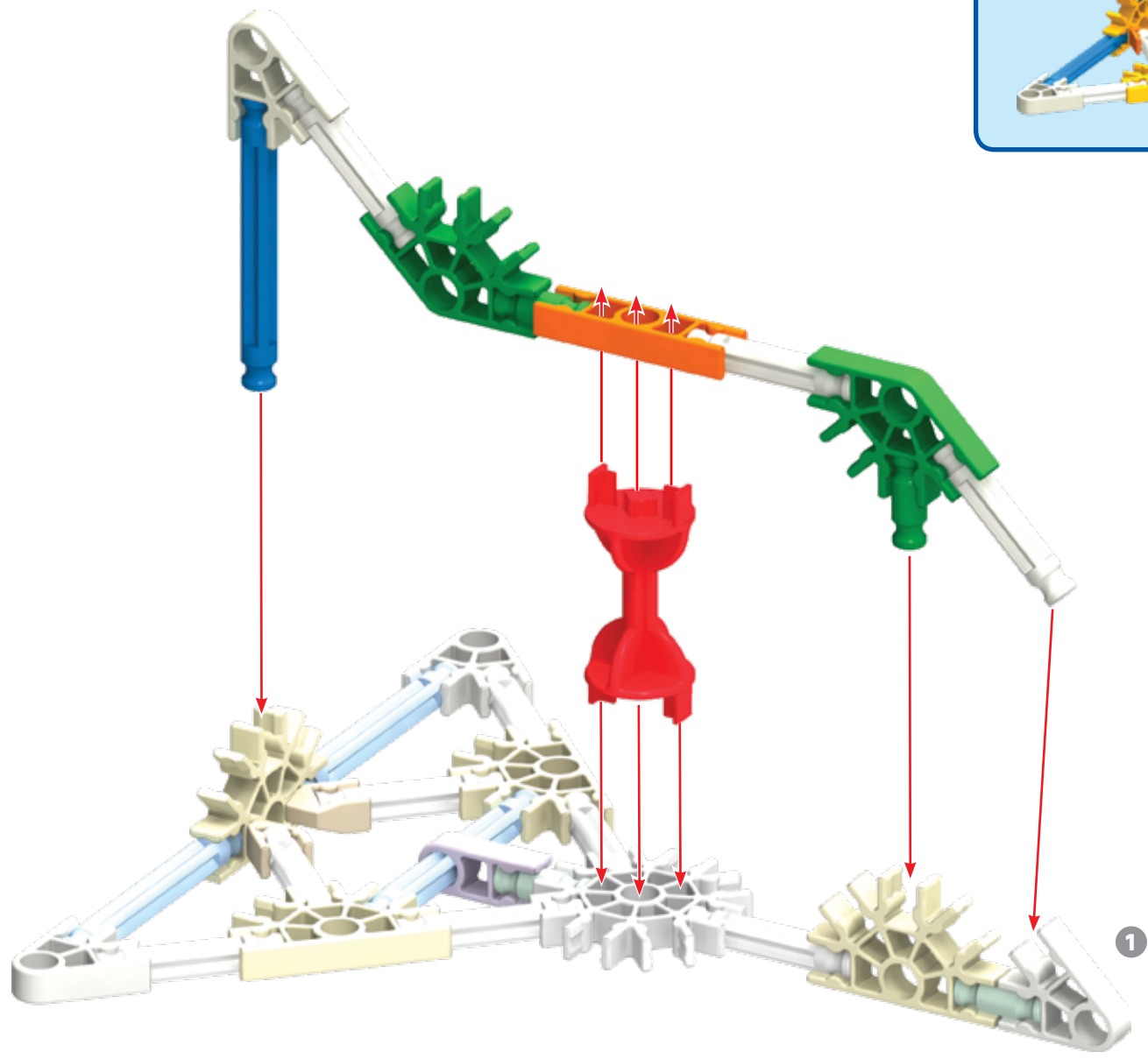
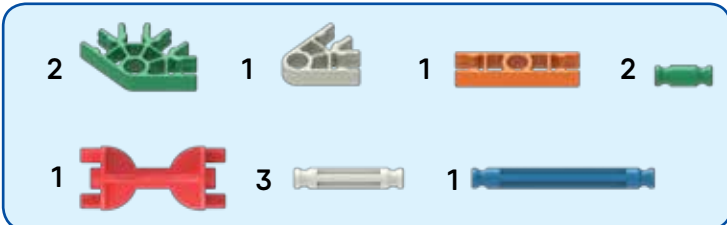

1

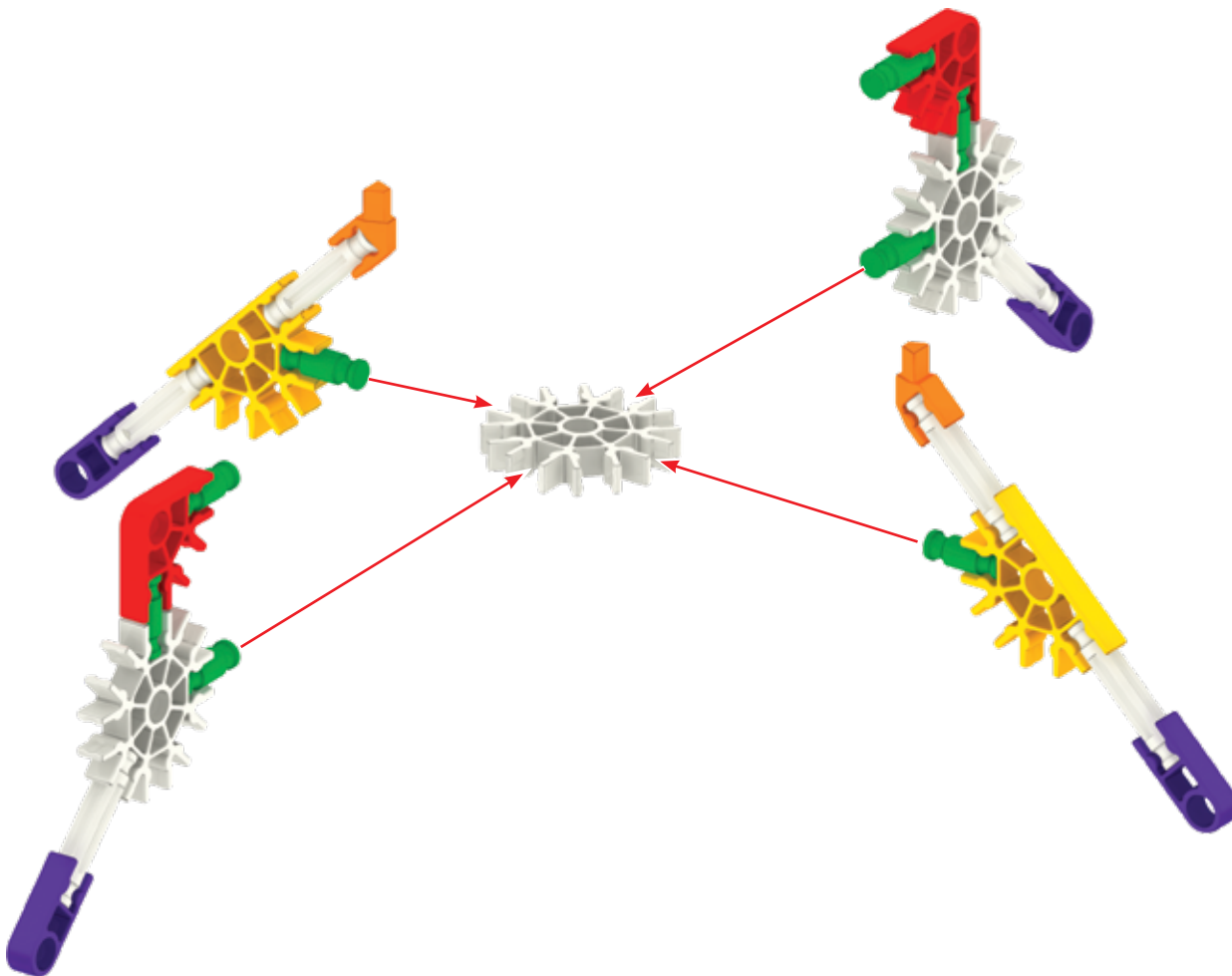

2

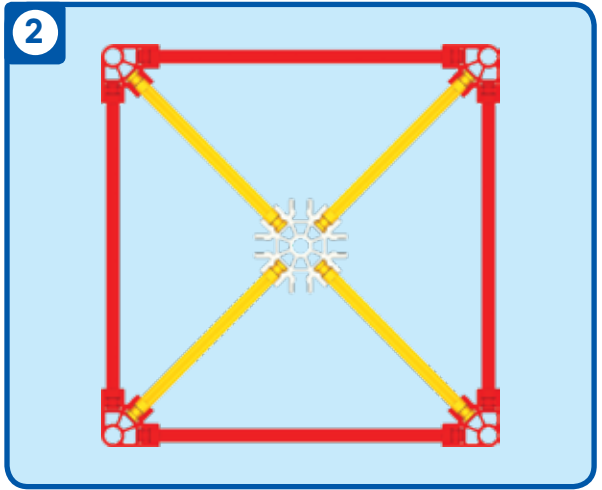
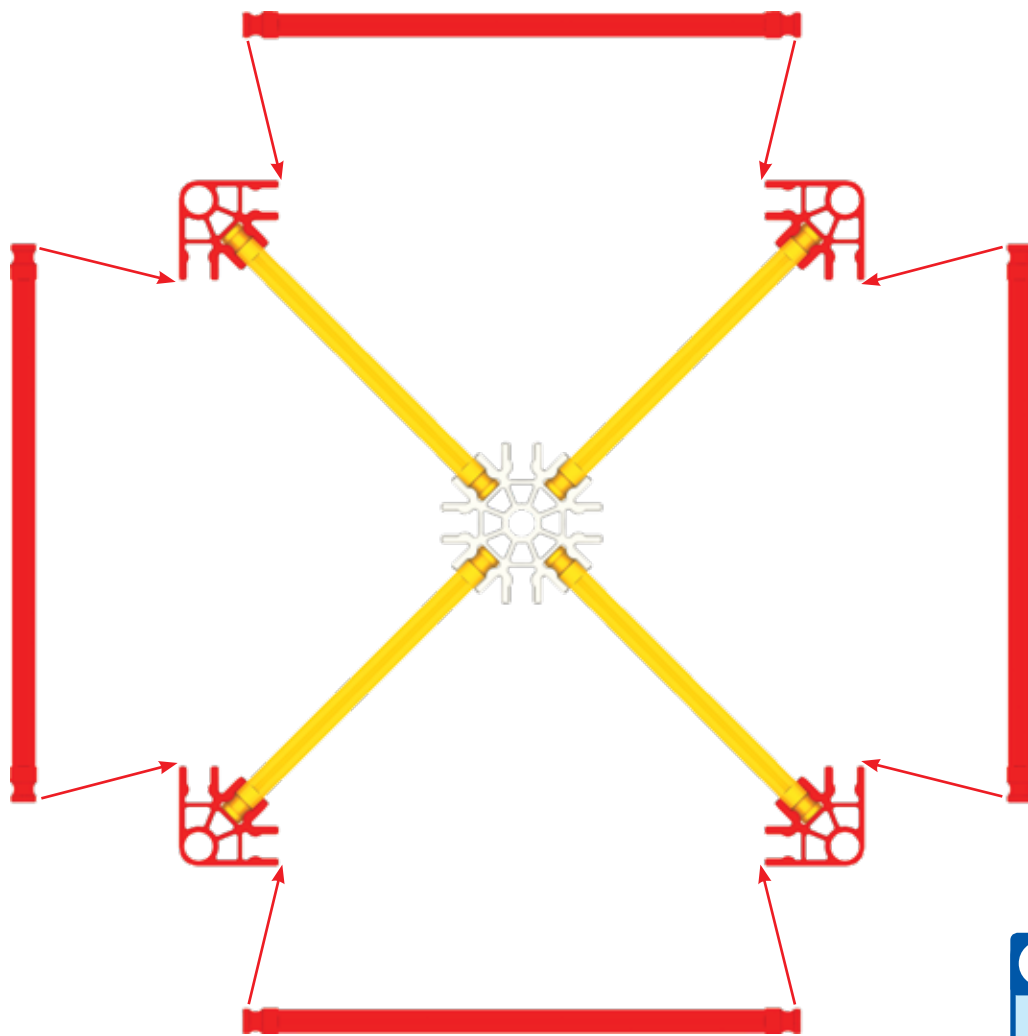

3

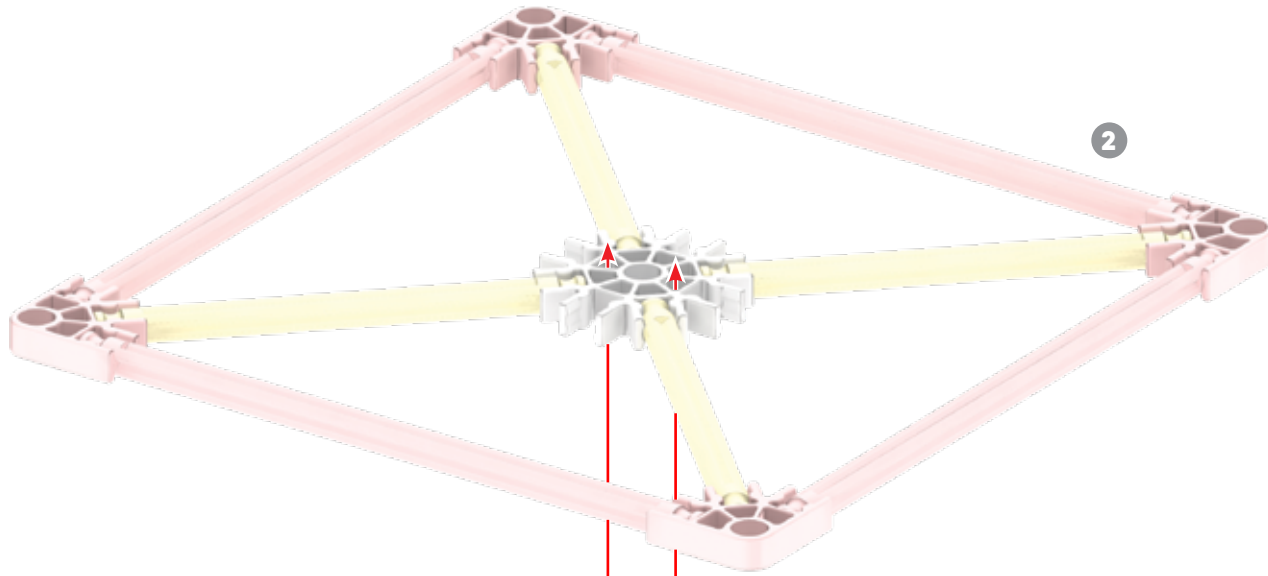

2

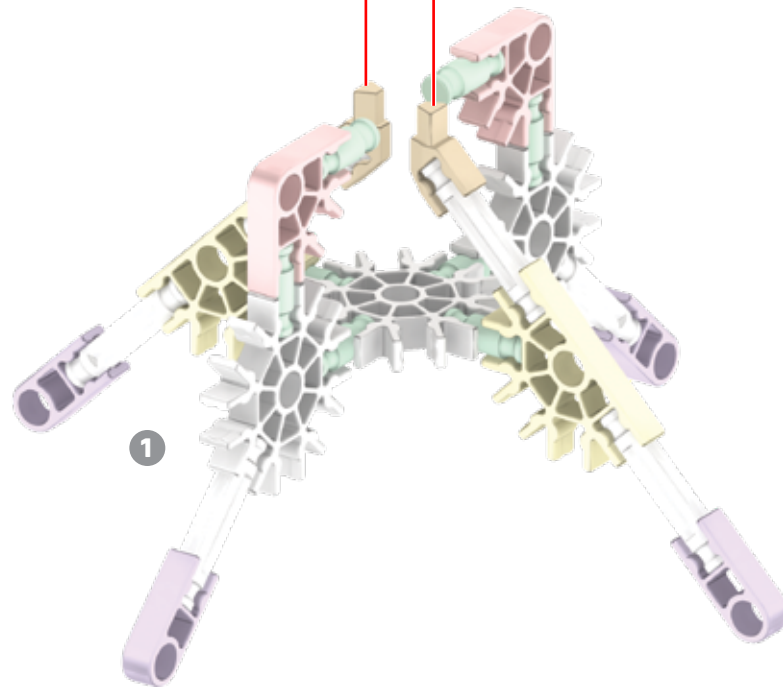

1

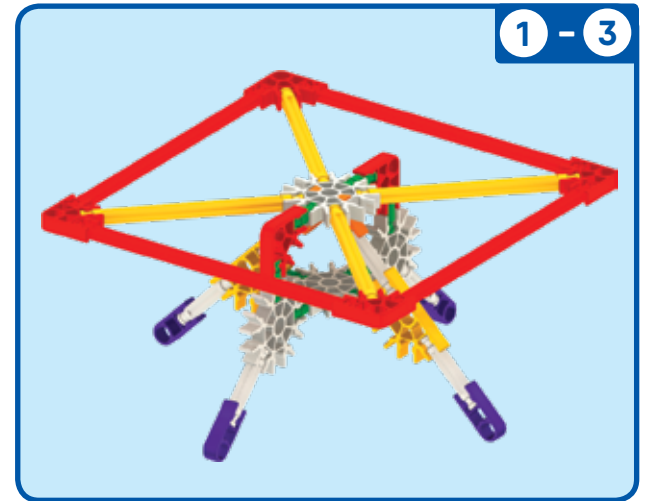

1 - 3

4

X2

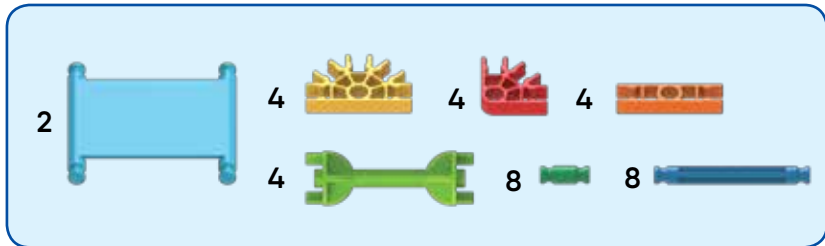
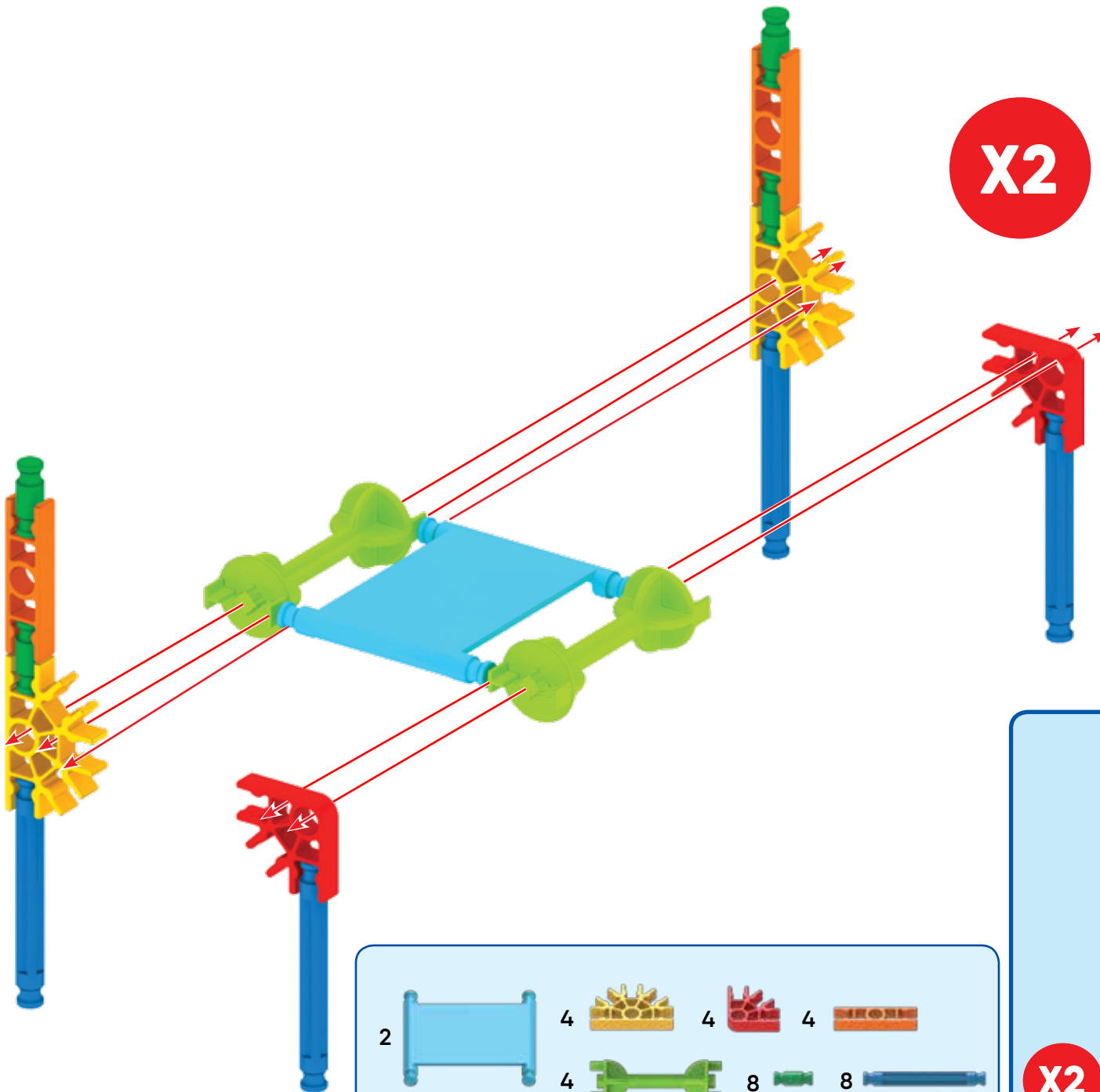

4

X2

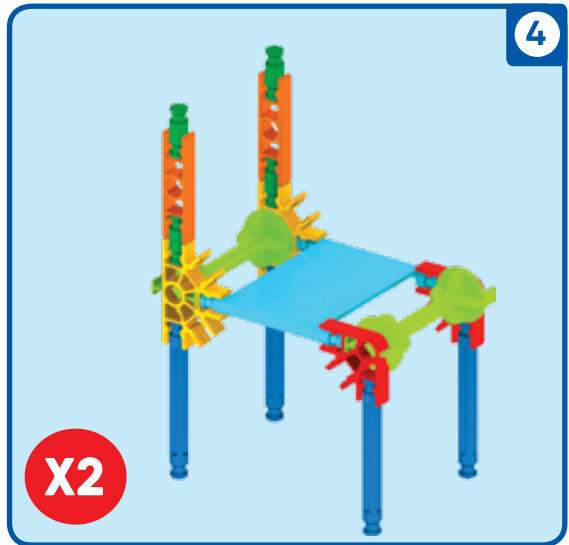

5

X2

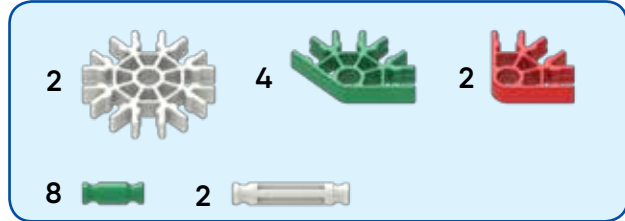
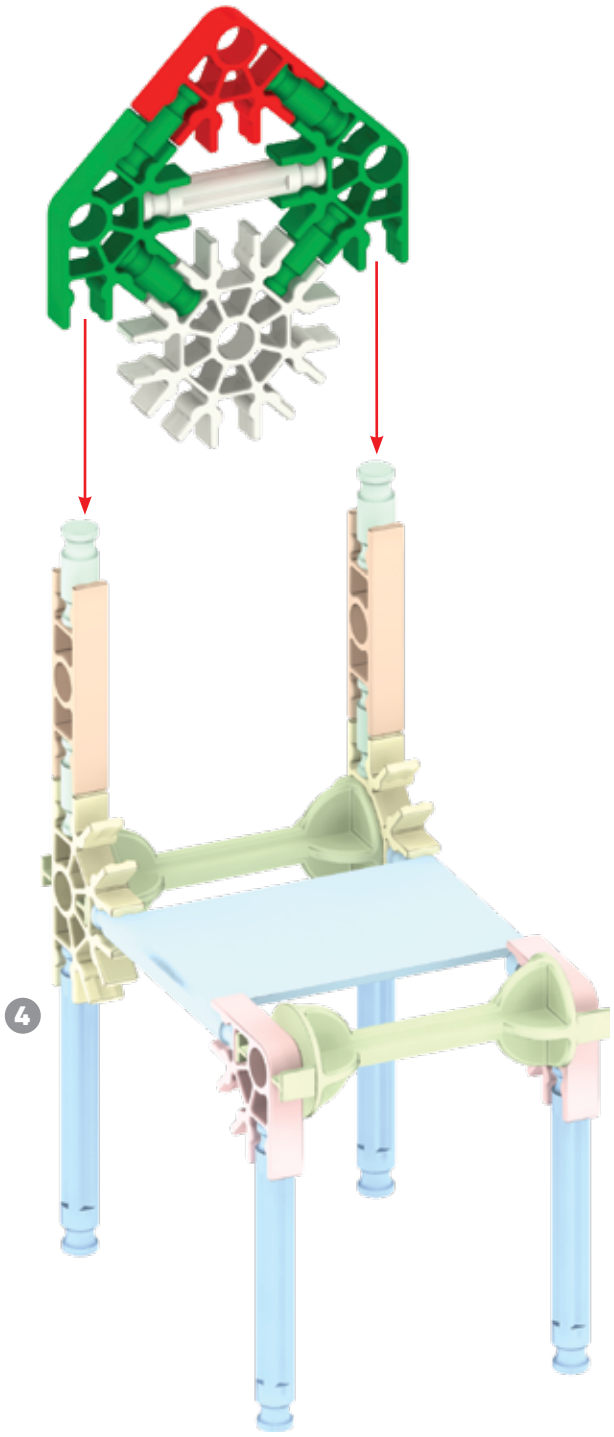

1

Ladder



X2



6



4



8



1



X2

2

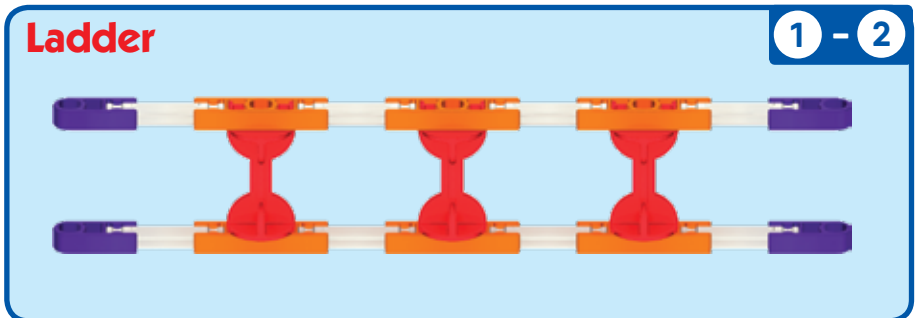
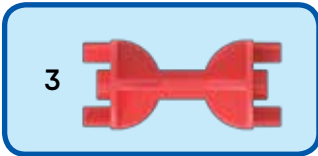
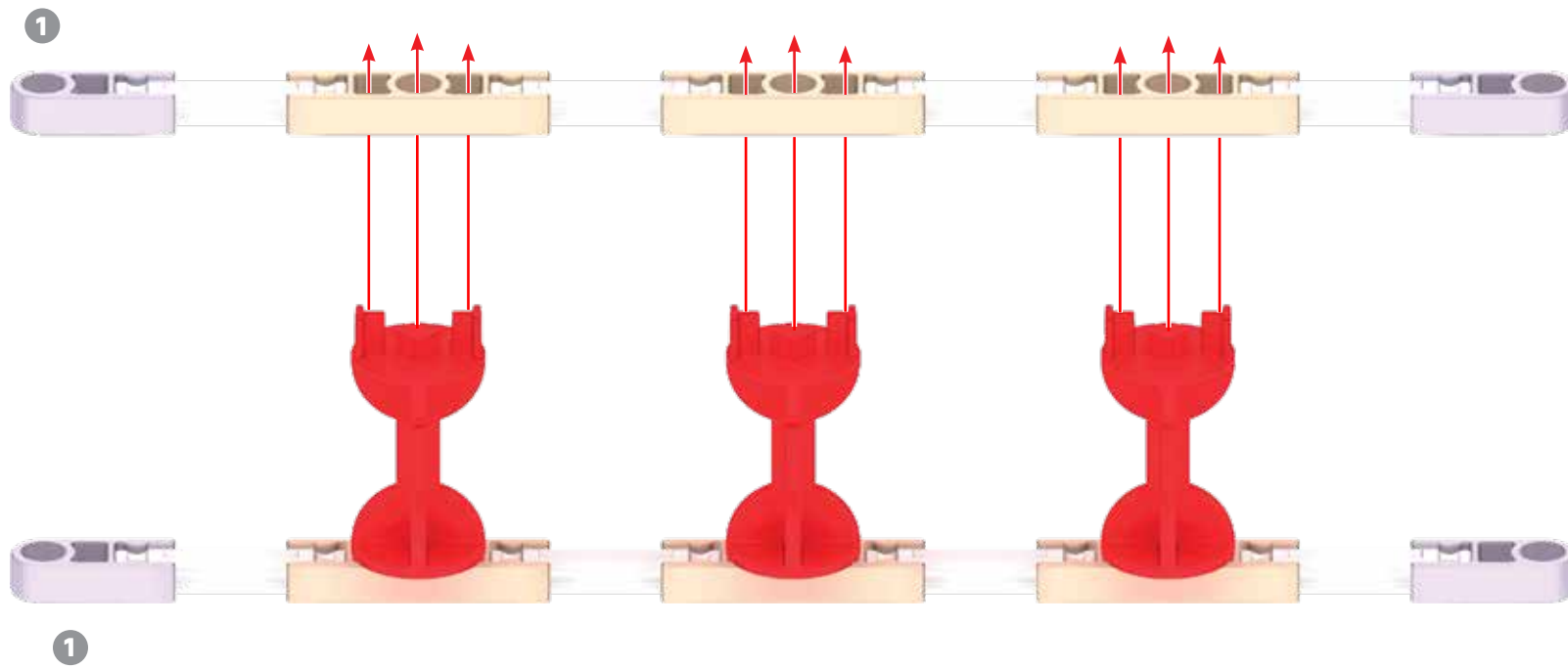

1

Merry-Go-Round

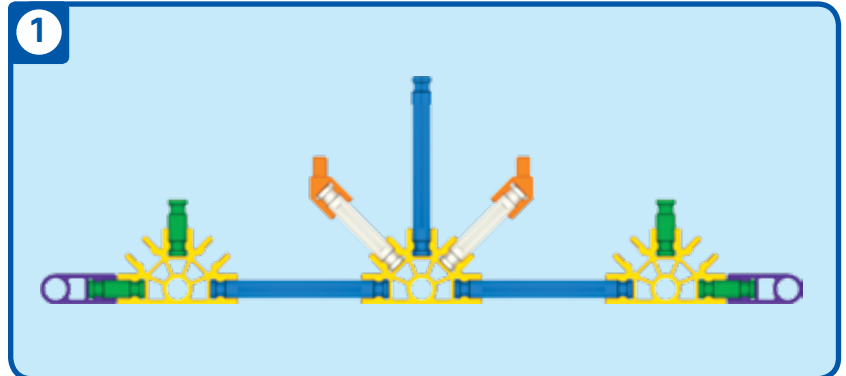
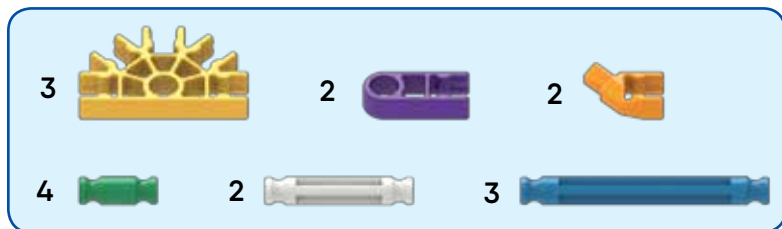
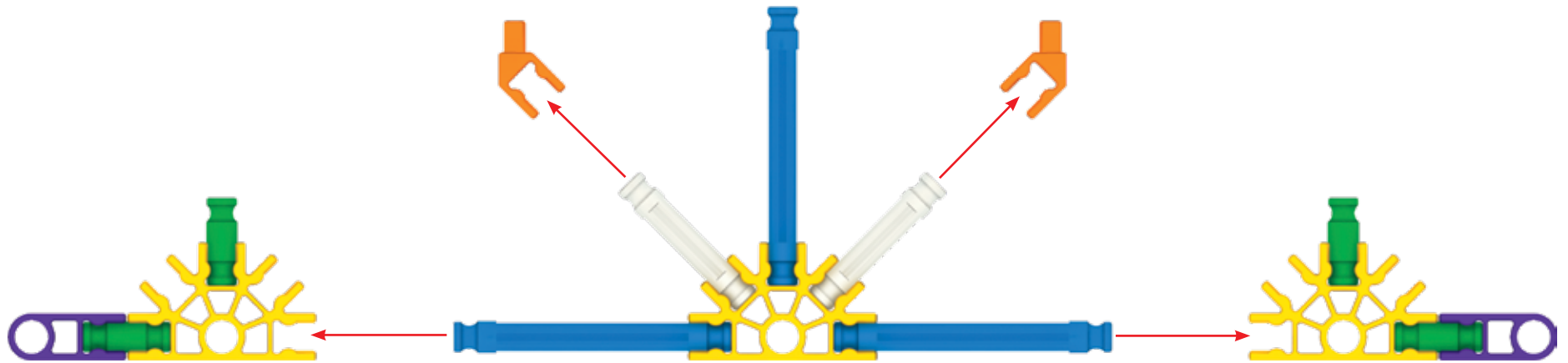

2

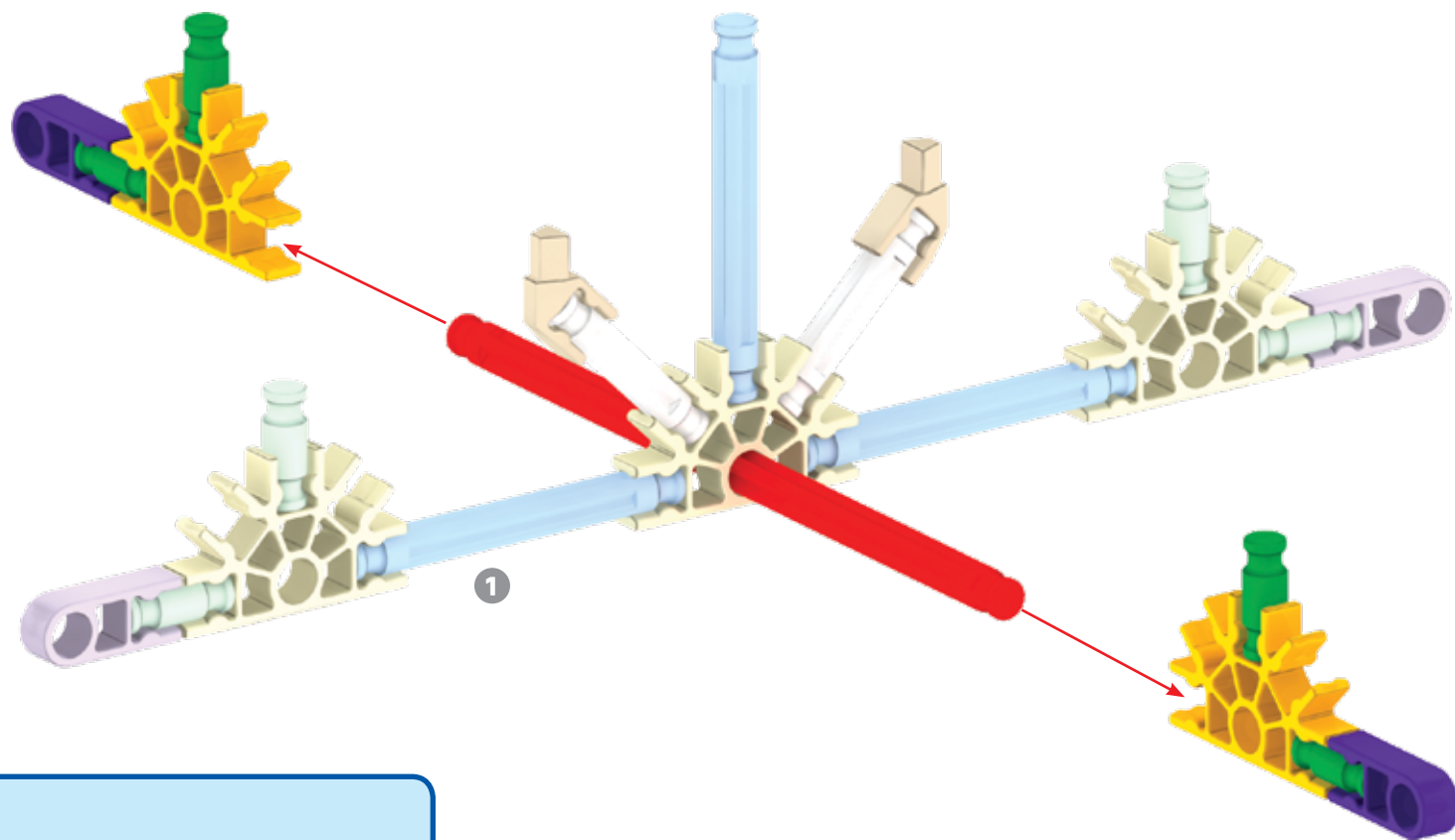

1 - 2

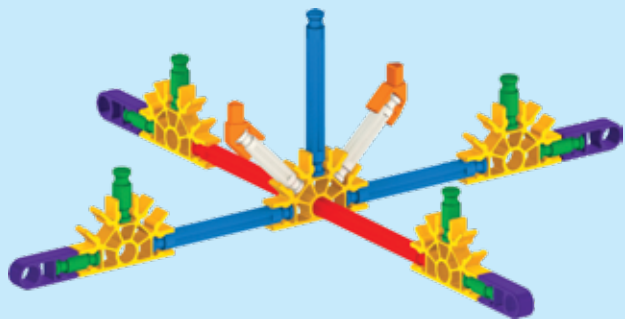

2



2



4



1



3

1 4 4 8



1 - 3

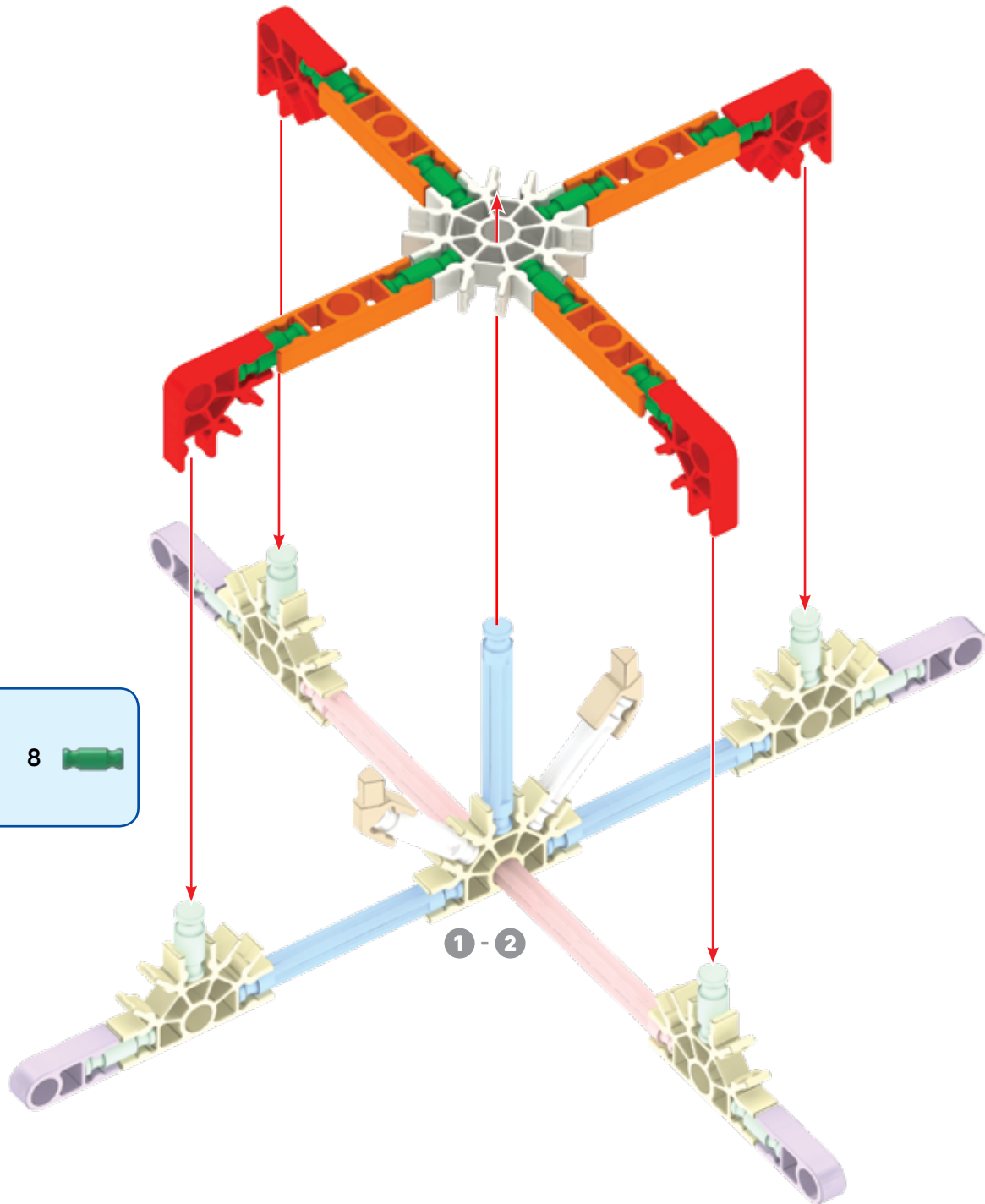
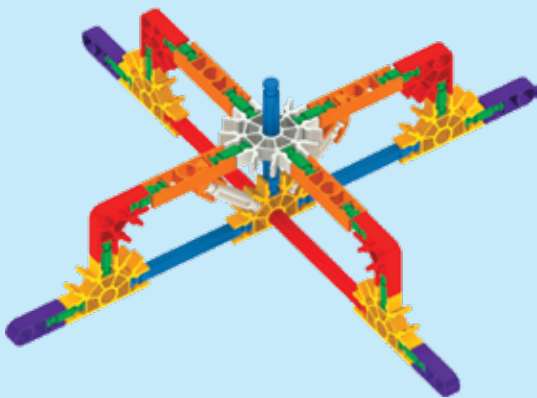

4

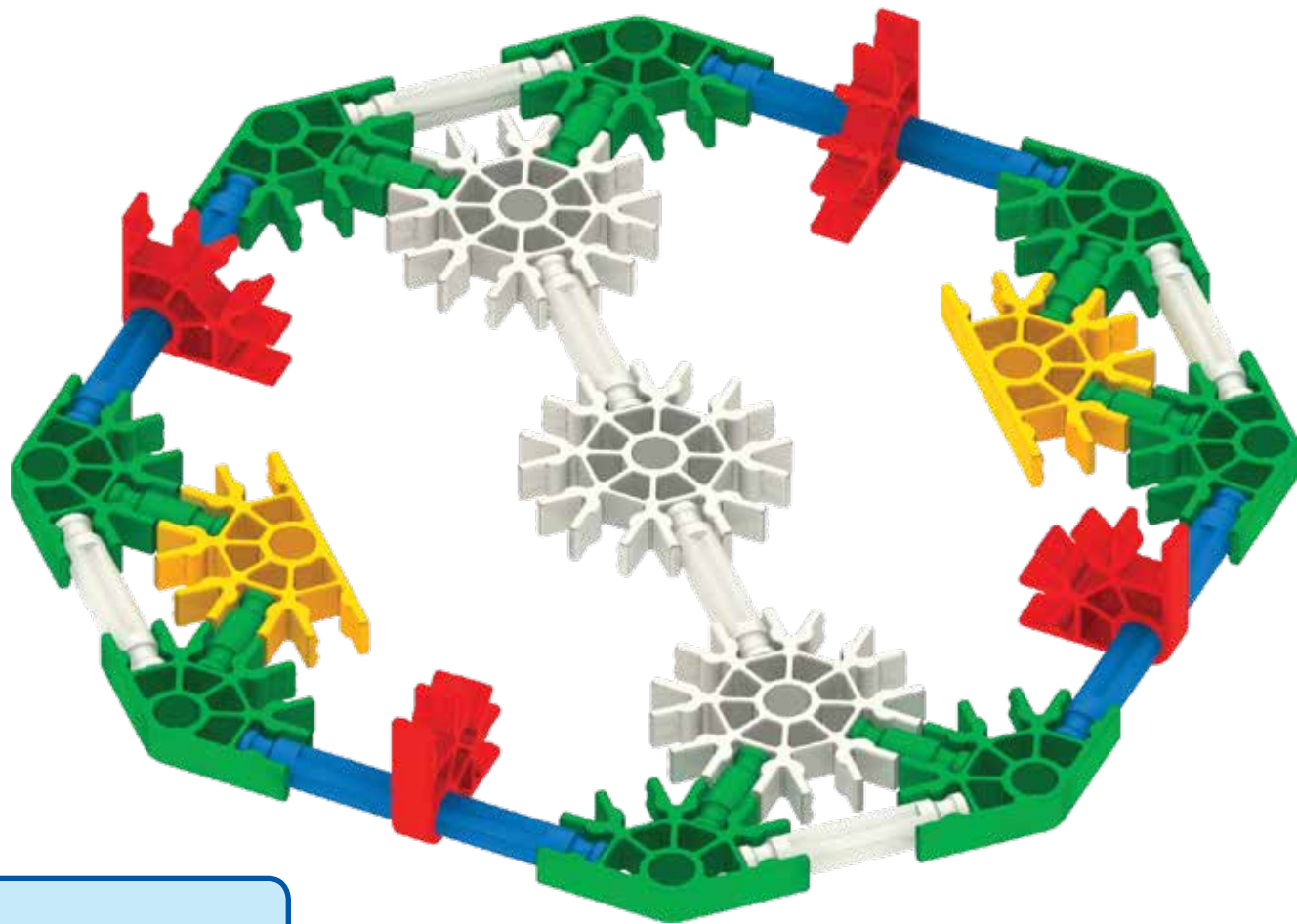

4

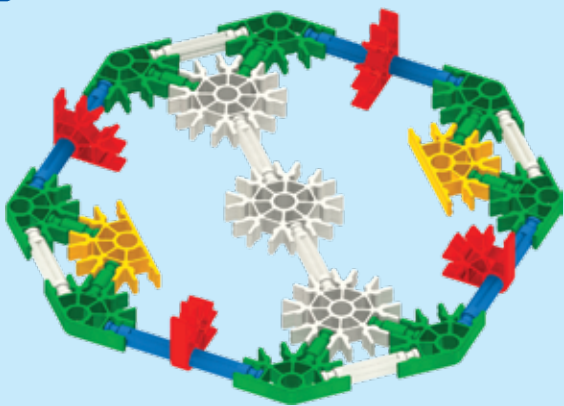

- | | | | | | | | |
|---|--|---|--|---|--|---|--|
| 3 | | 2 | | 8 | | 4 | |
| 8 | | 6 | | 4 | | | |

5

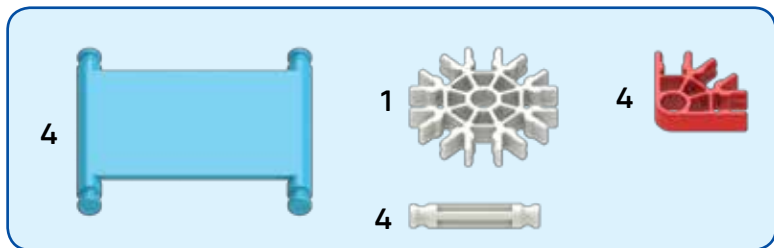
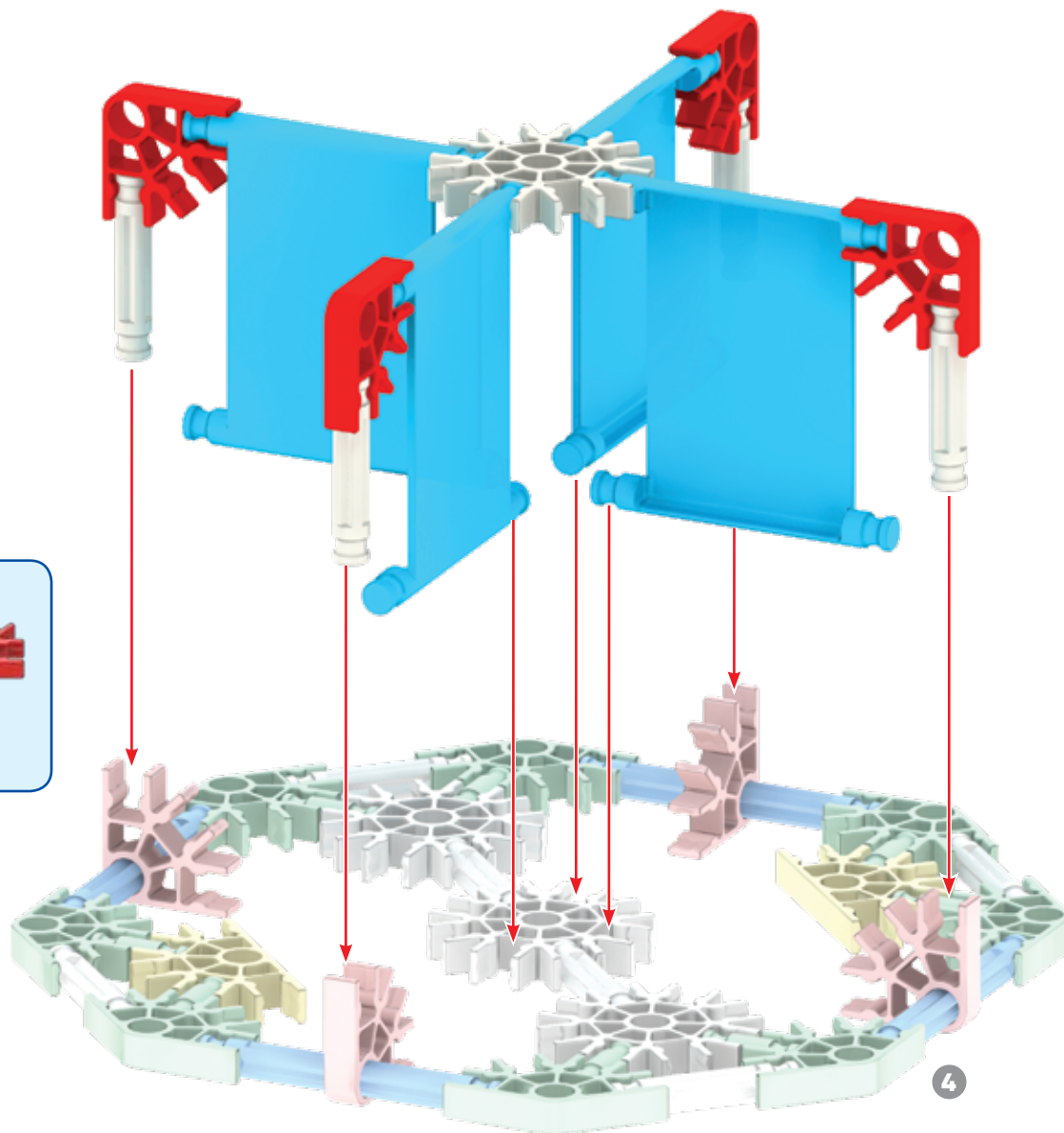

5

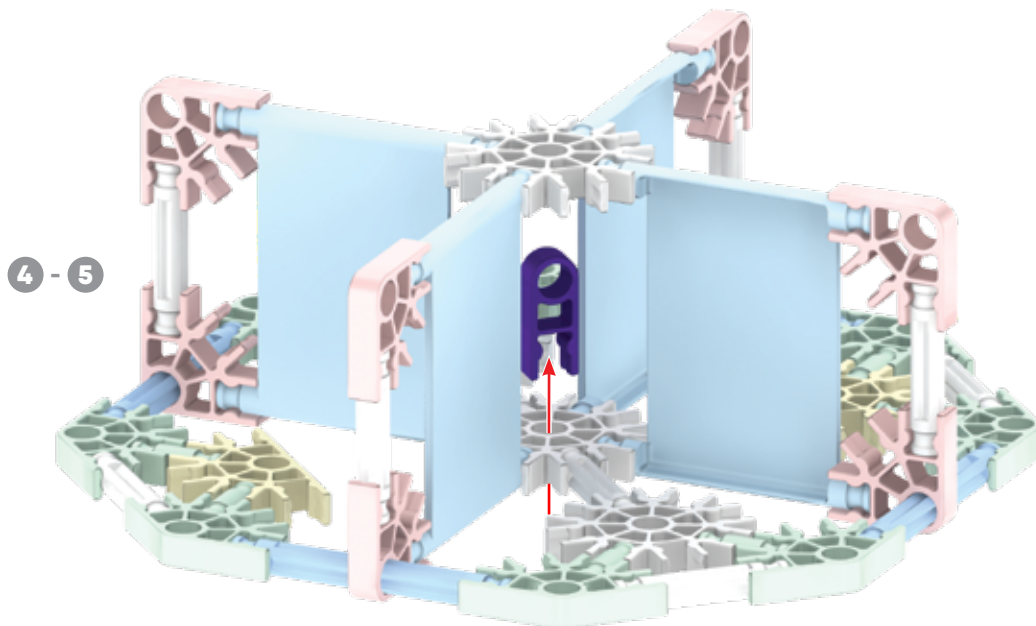

4 - 5

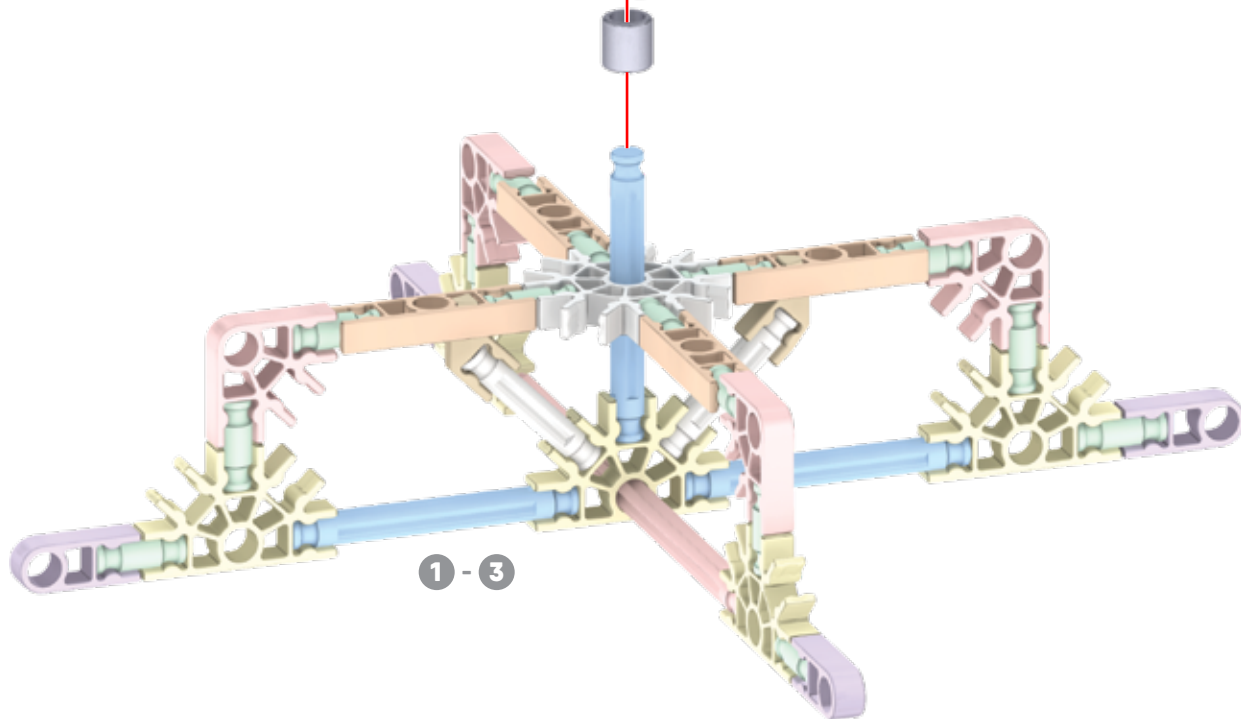

1 - 3



1 - 6

1

X2

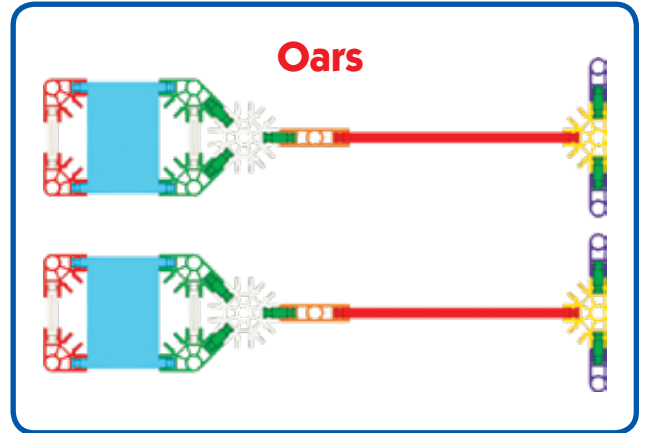
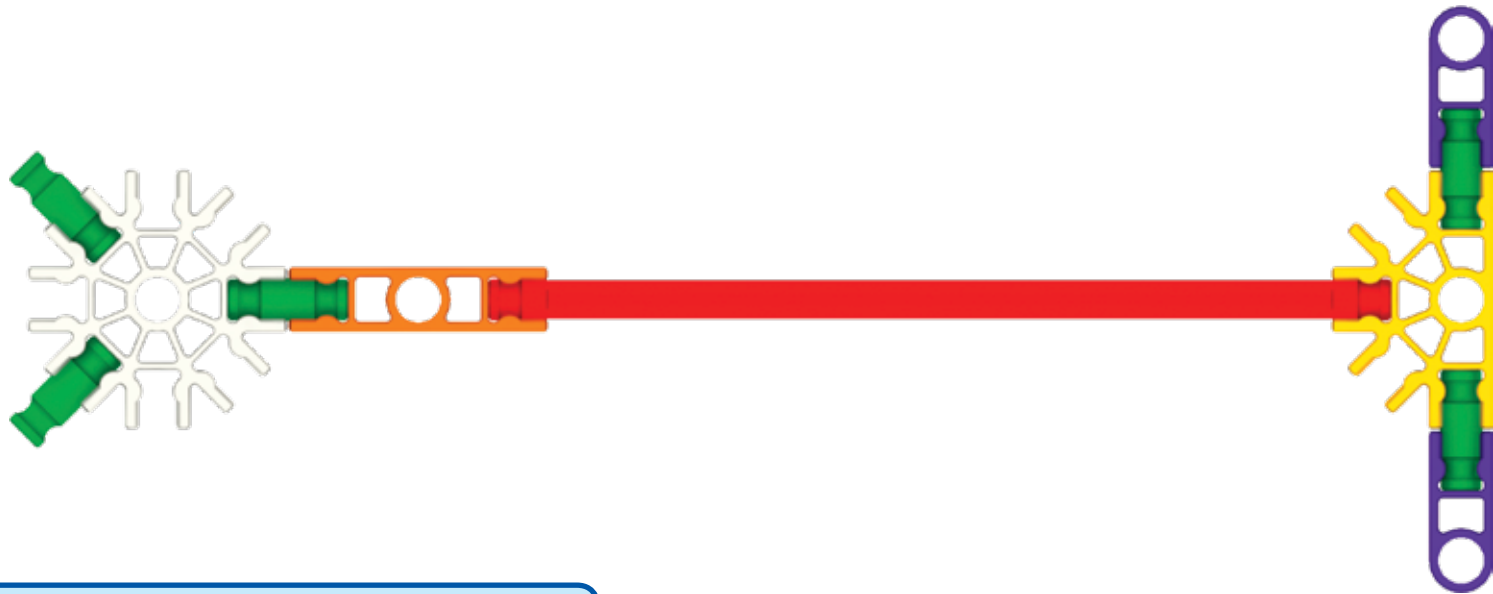

1

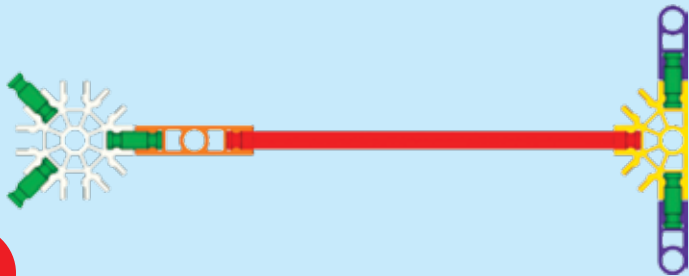

X2

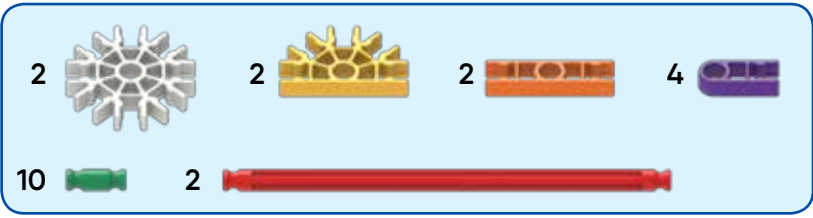

2

X2

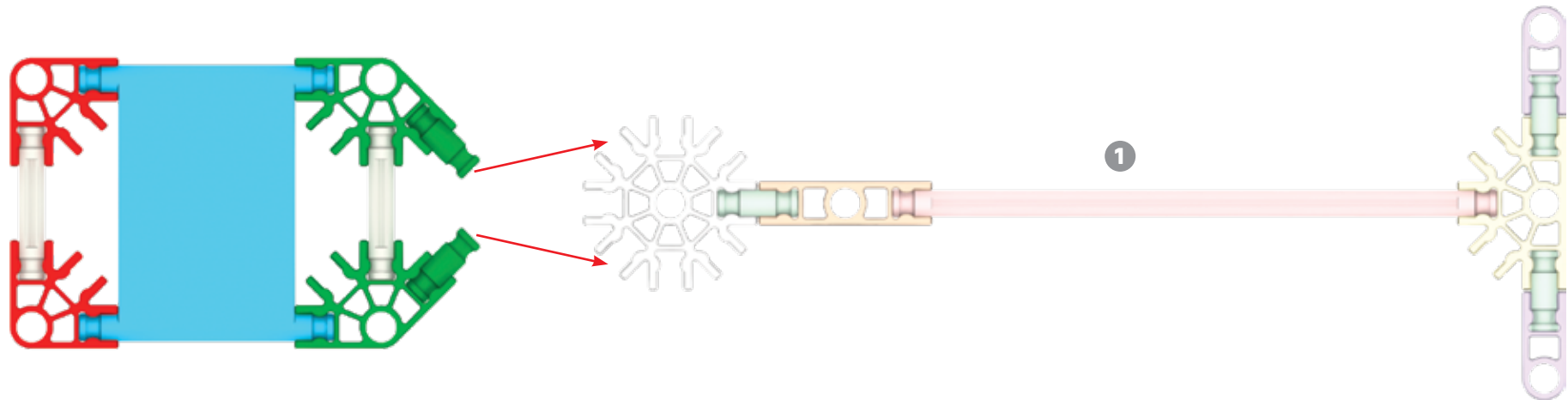

1 - 2

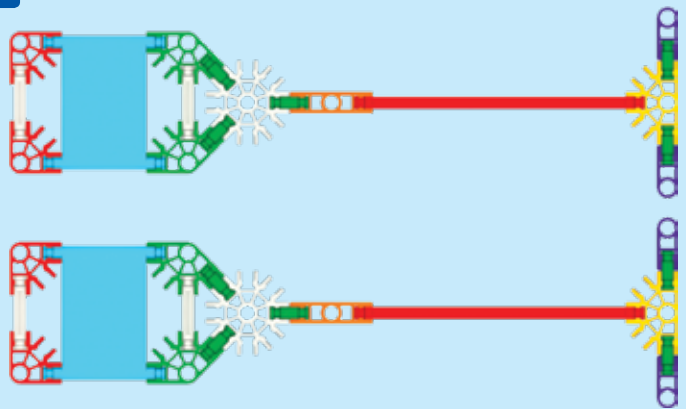

X2

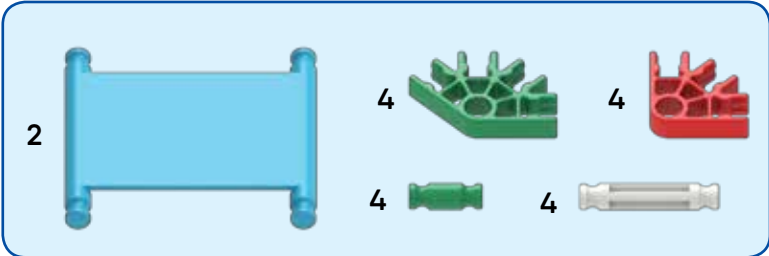

1

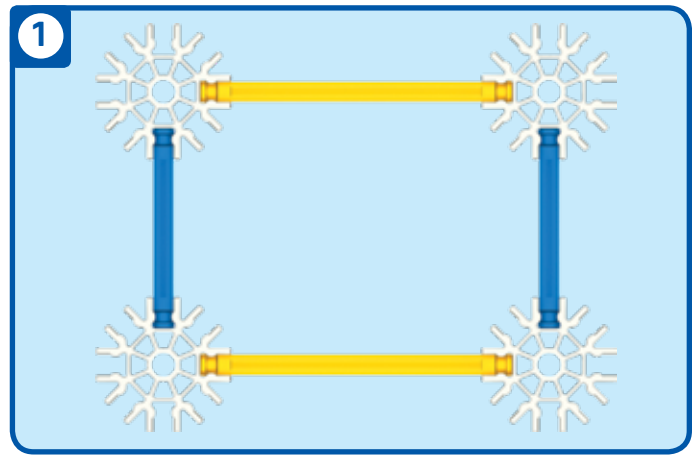
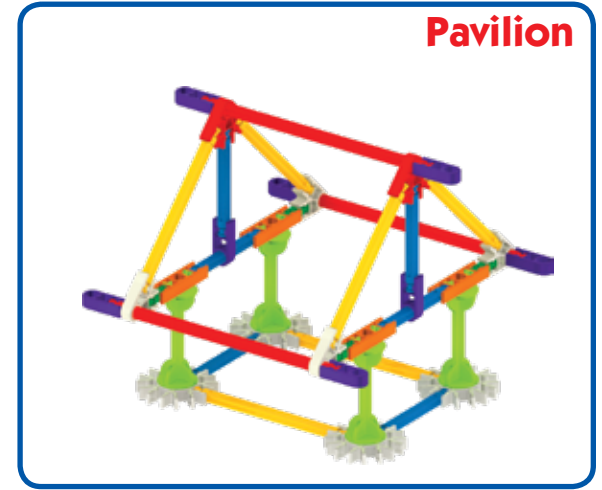

2

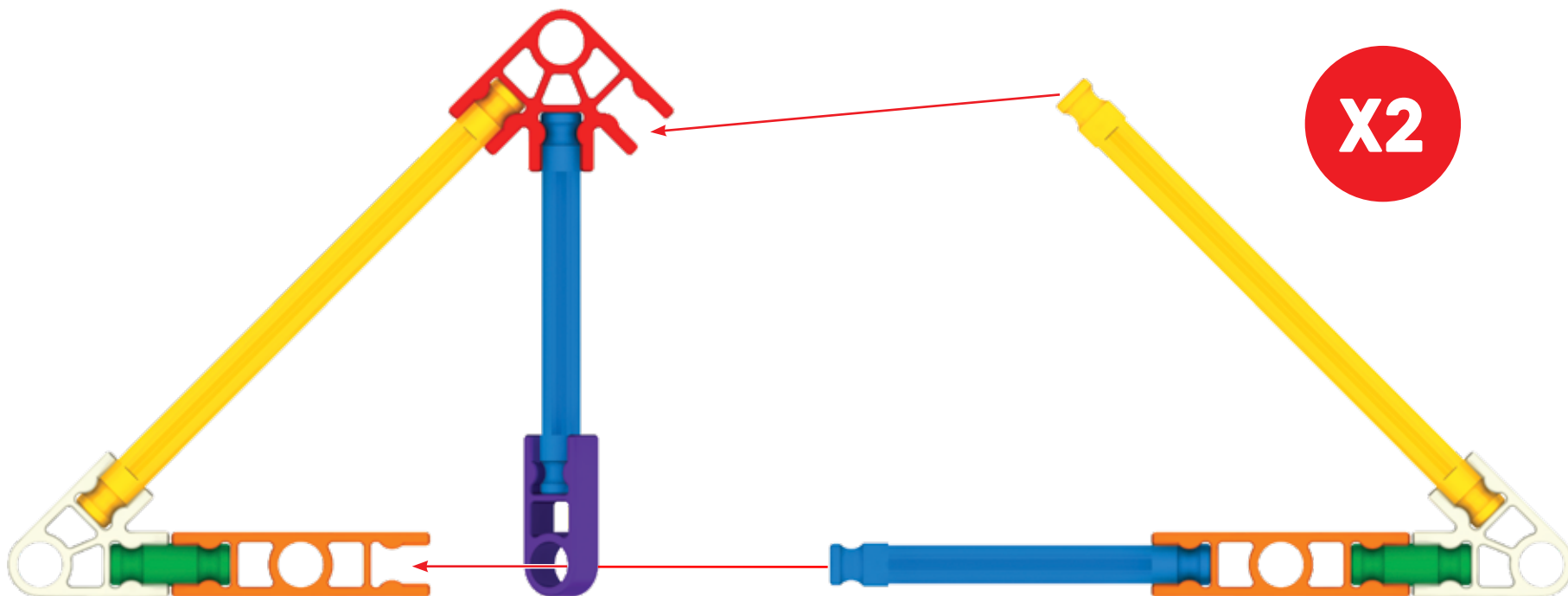

- 2  4  4  2 
- 4  4  4 

2

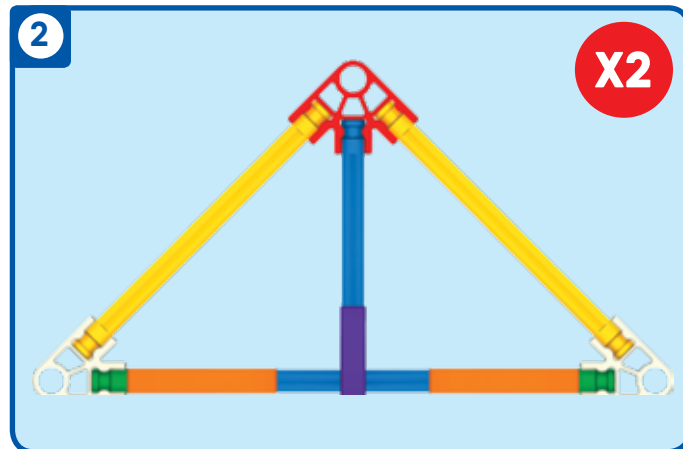

X2

3

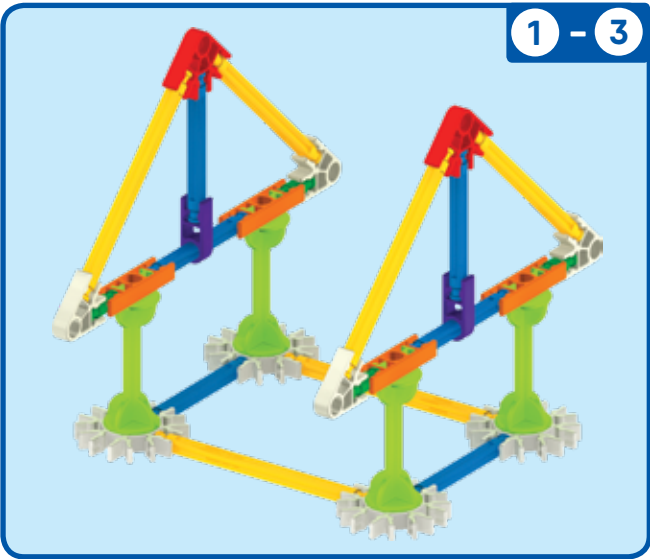
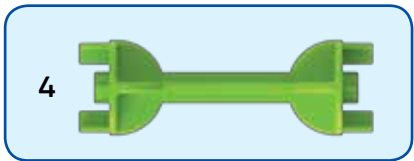
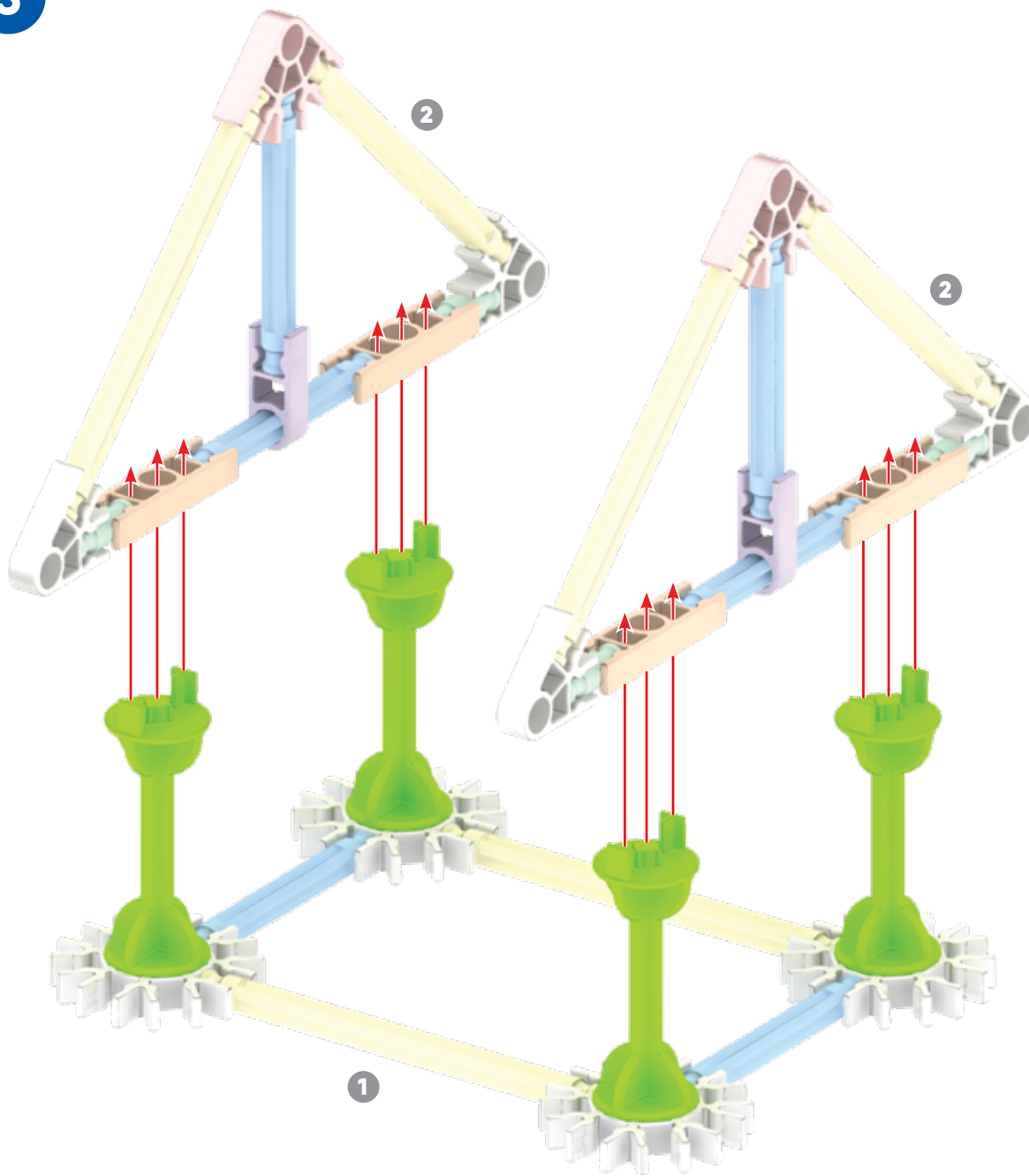

4

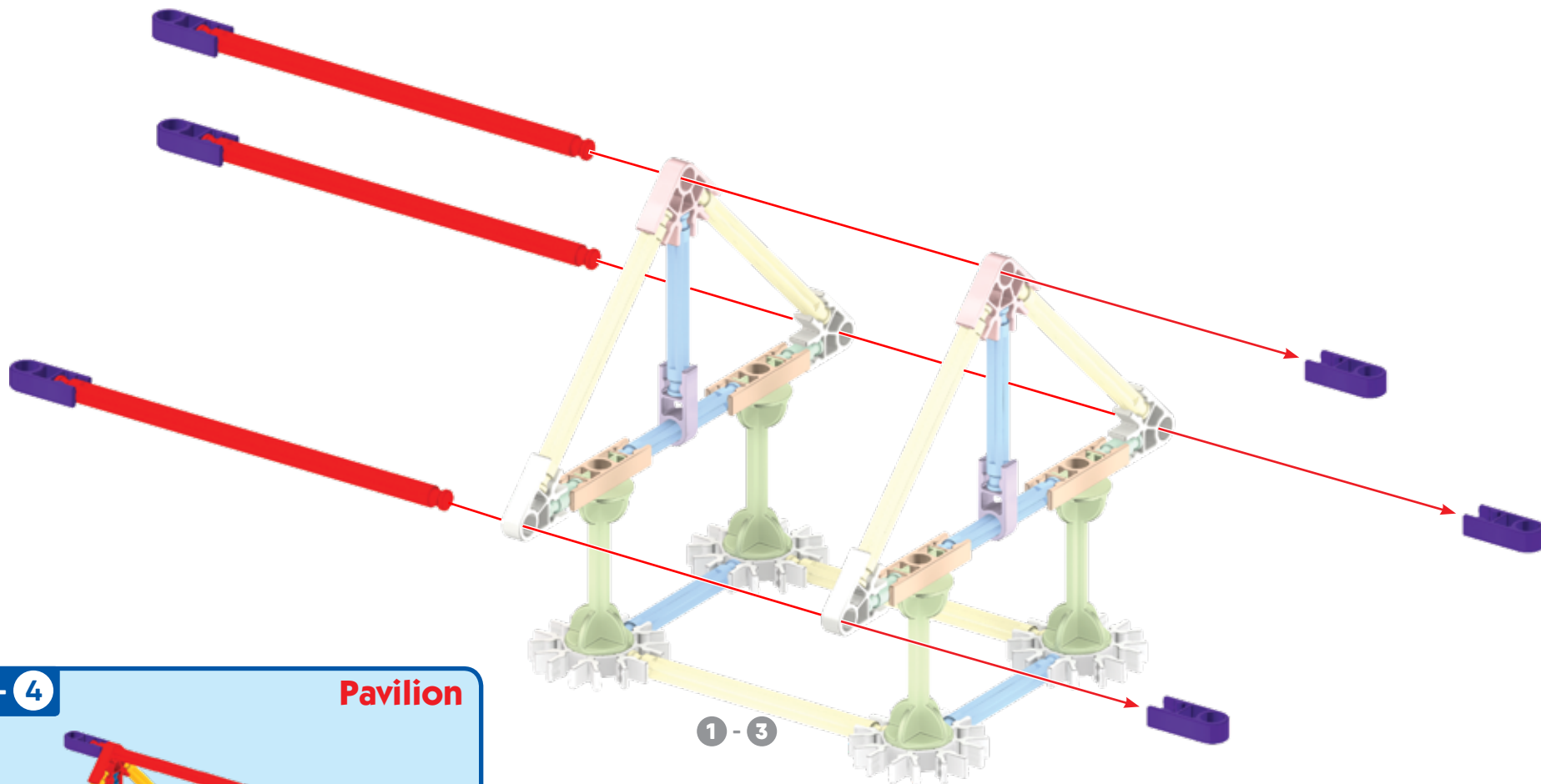

1 - 3

1 - 4

Pavilion

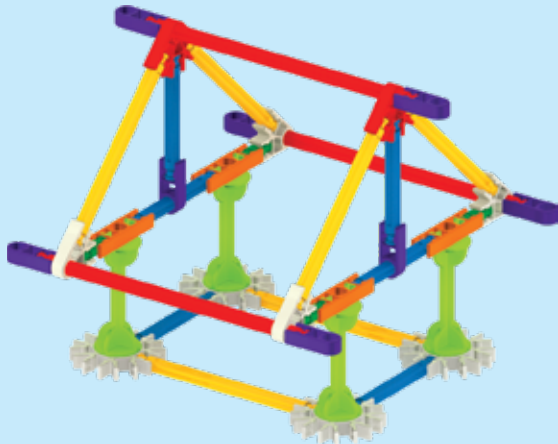

1

Pump Car



1



2

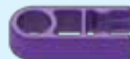

2



1



2

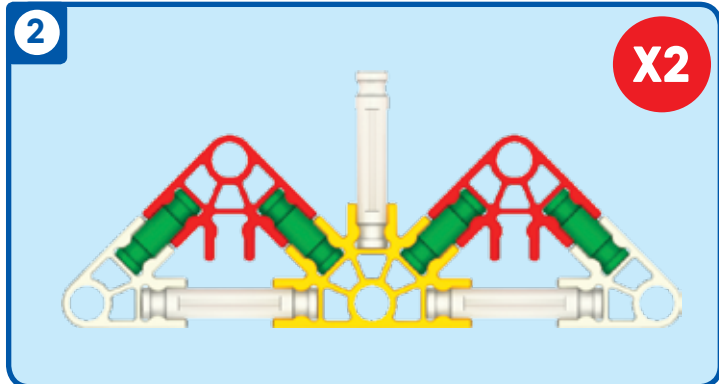
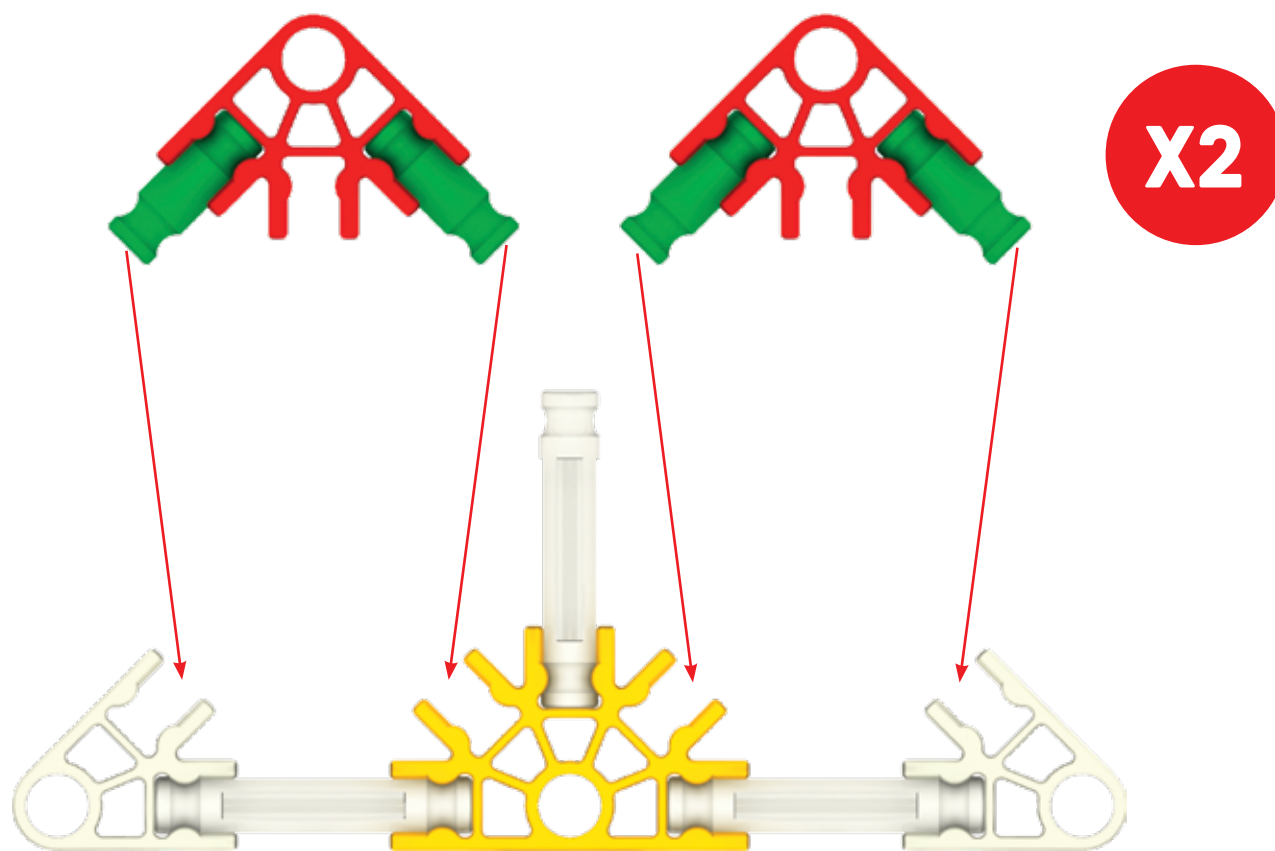

3

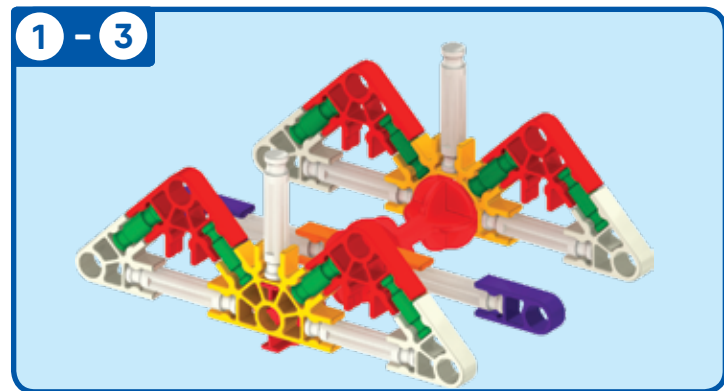
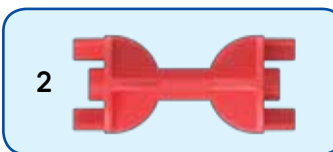
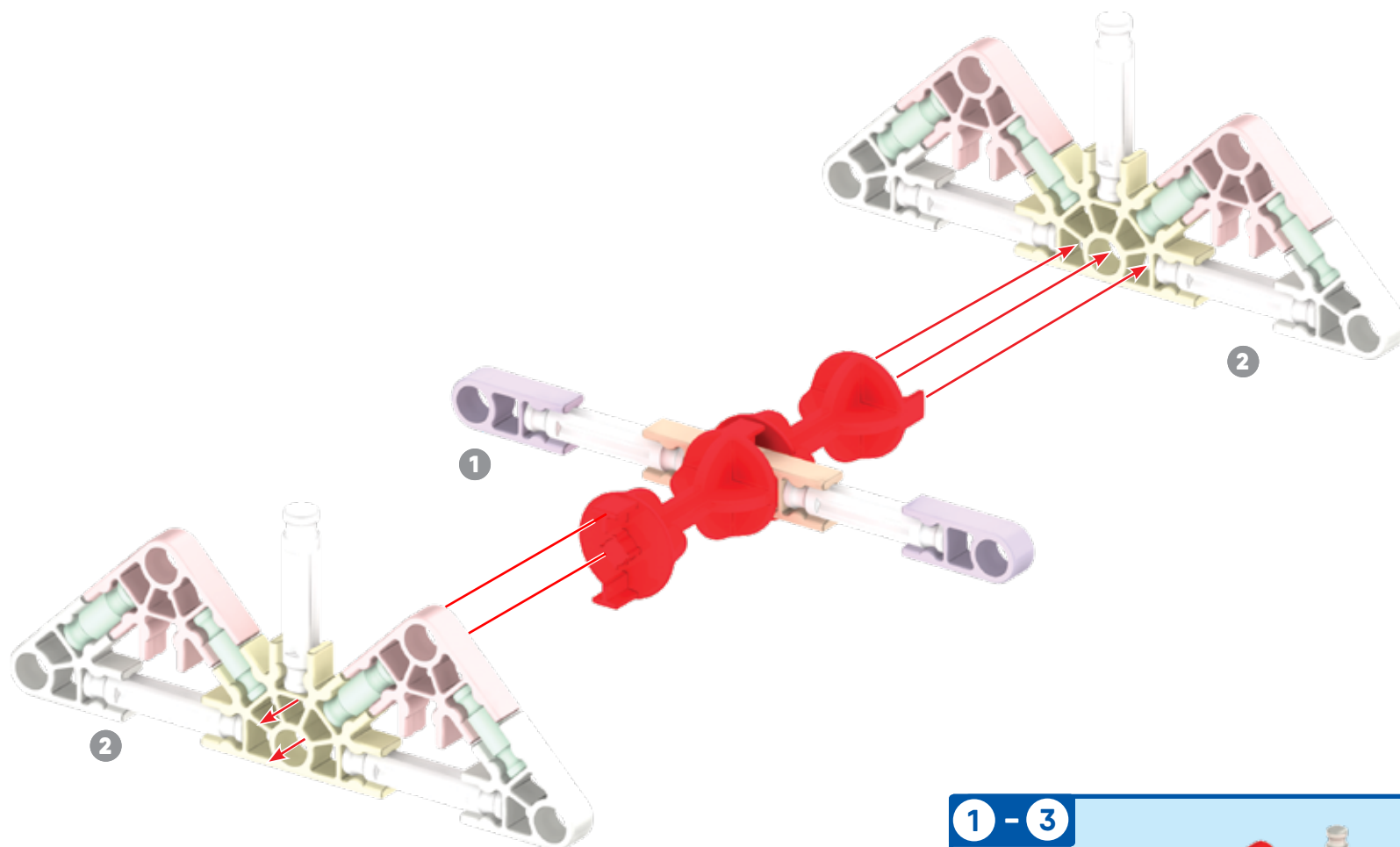

4

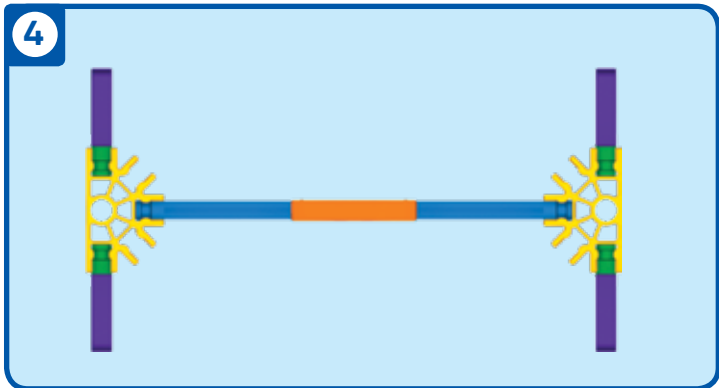

5

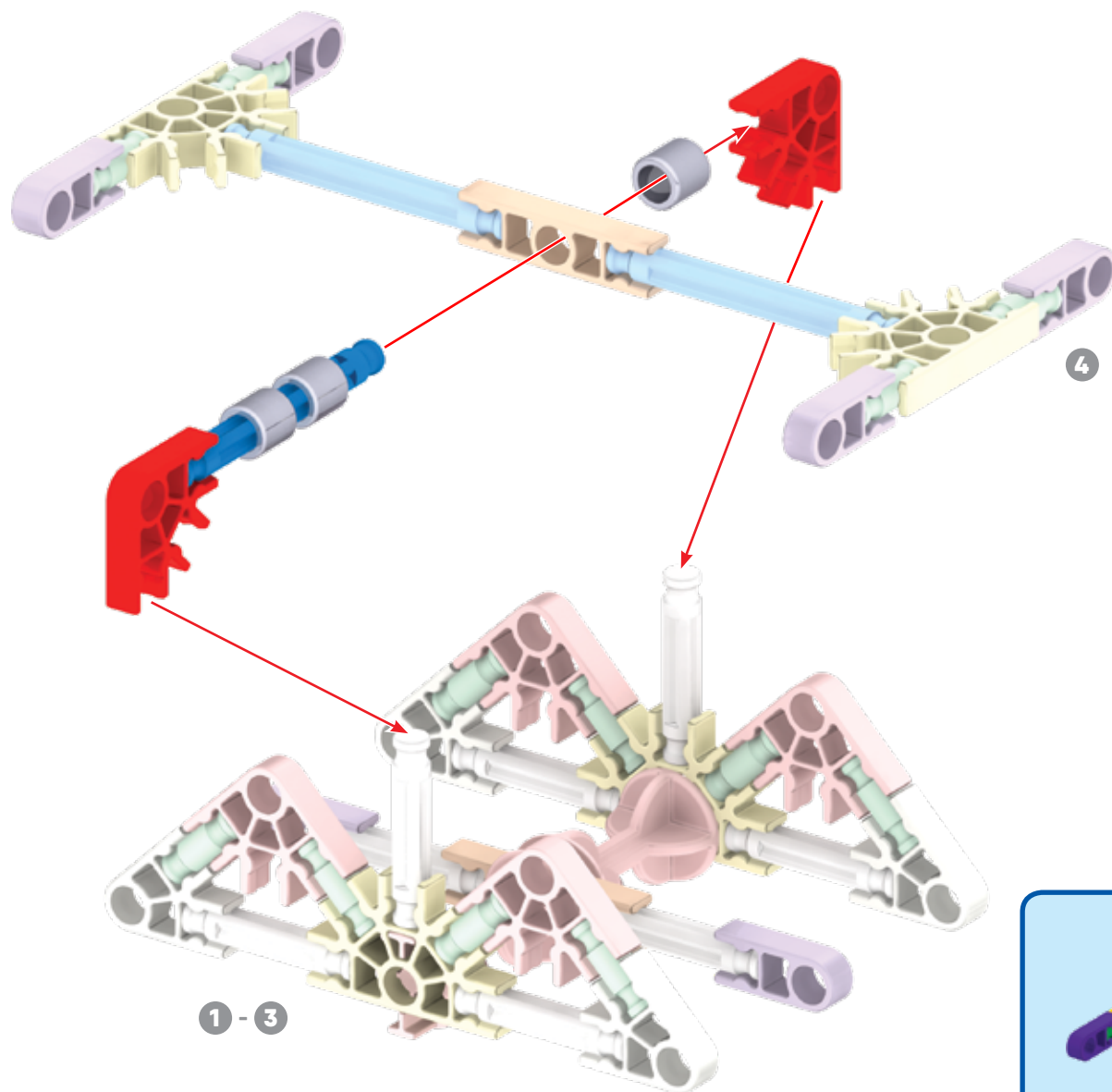

1 - 3

4



6

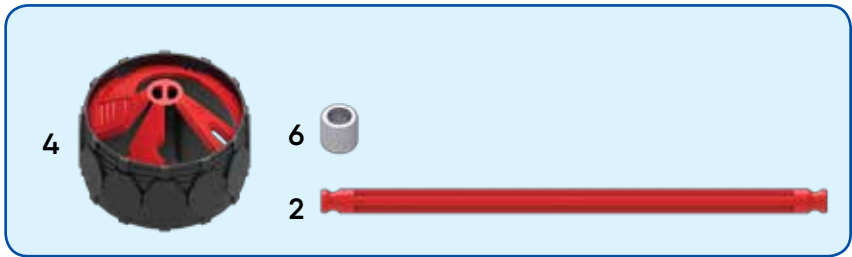
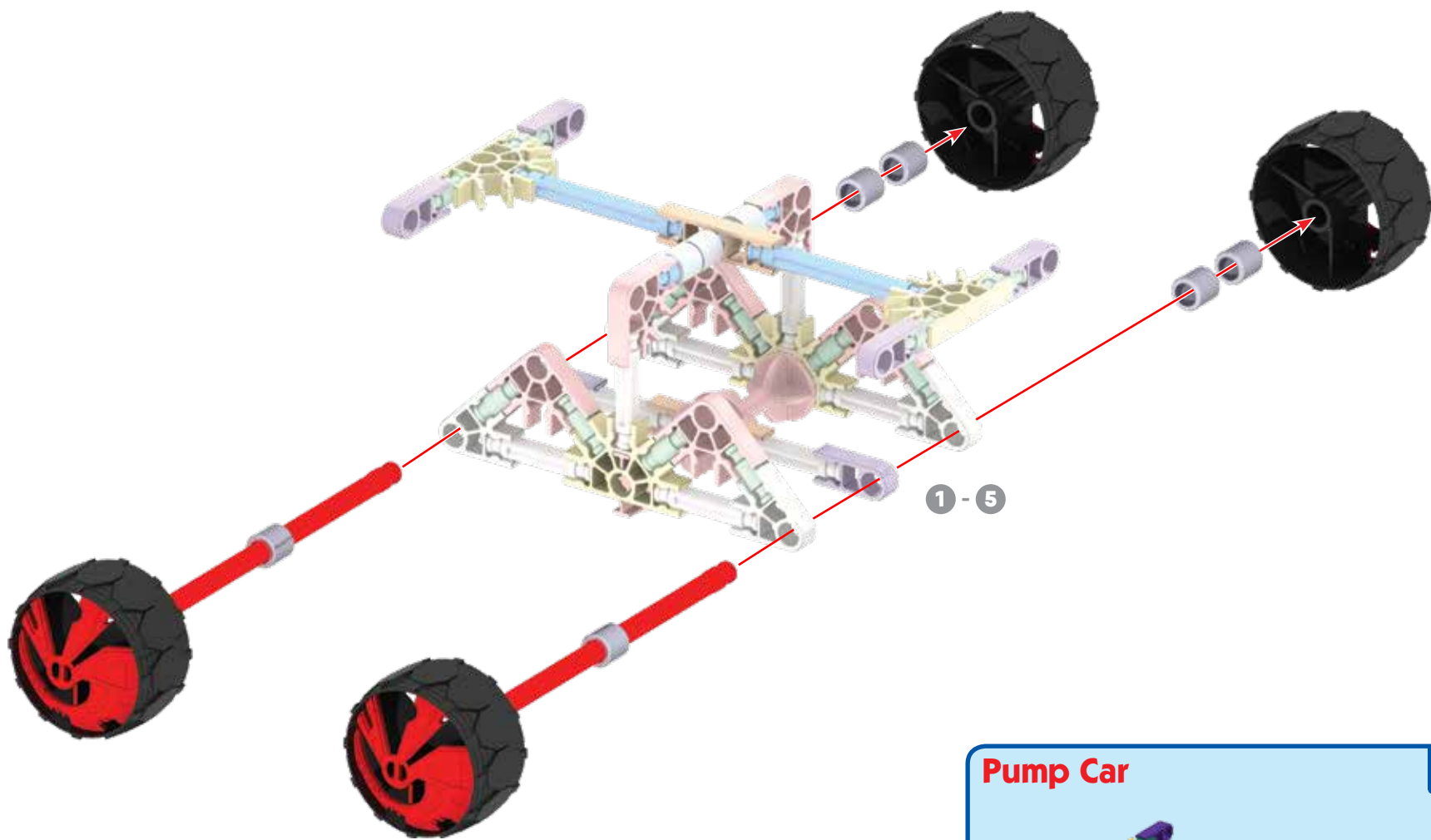

Pump Car

1 - 6



1

Rally Car



X2

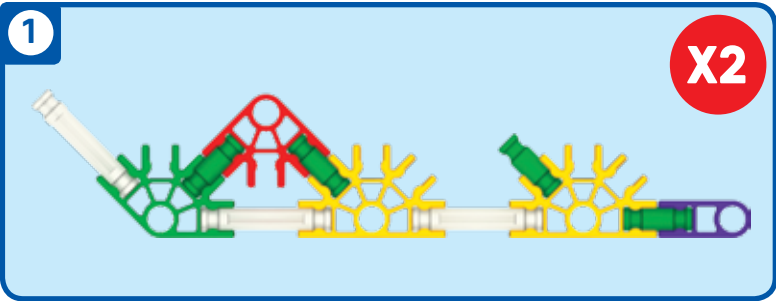
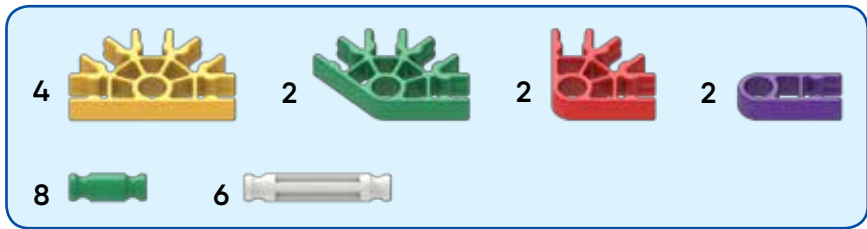
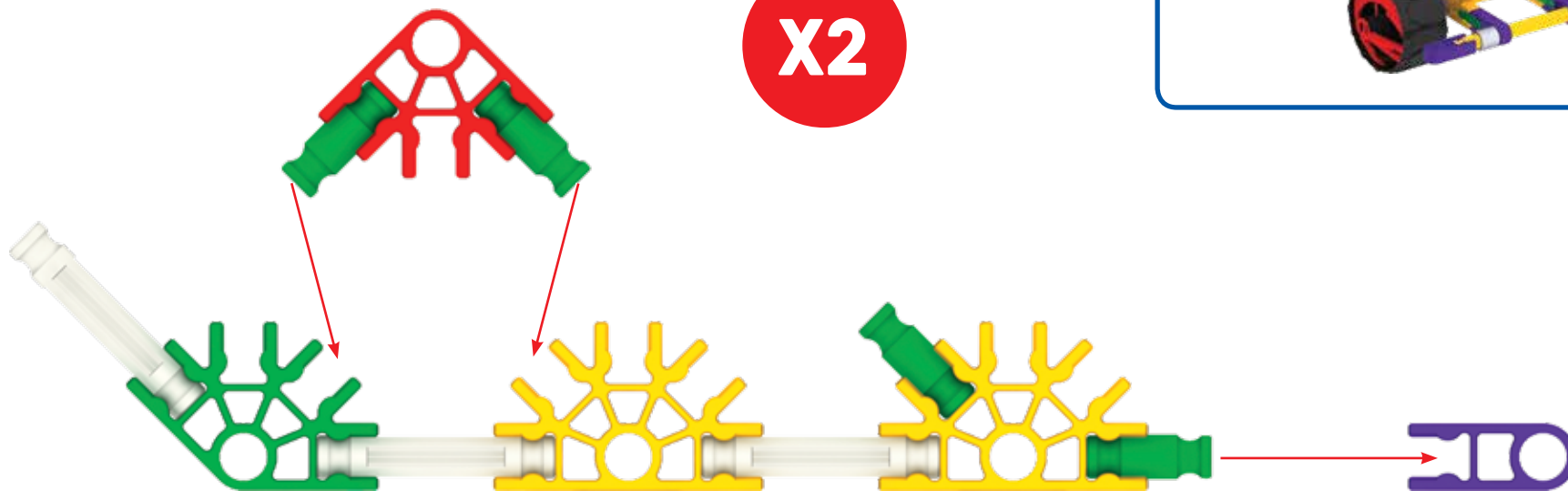

X2

2

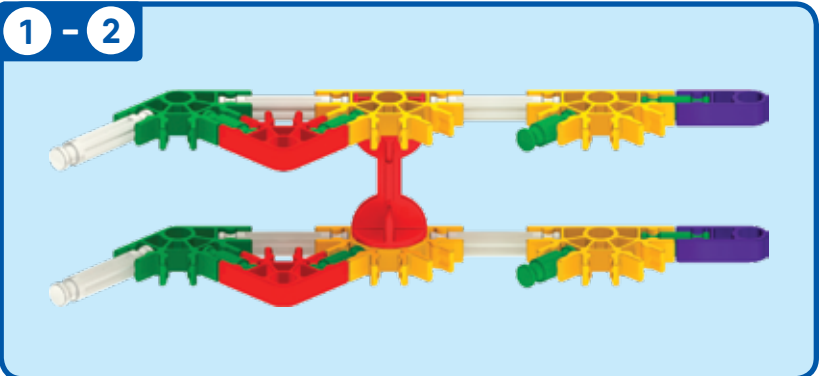
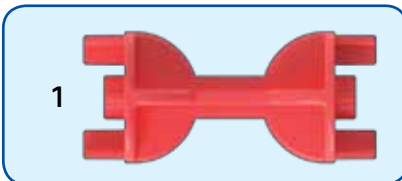
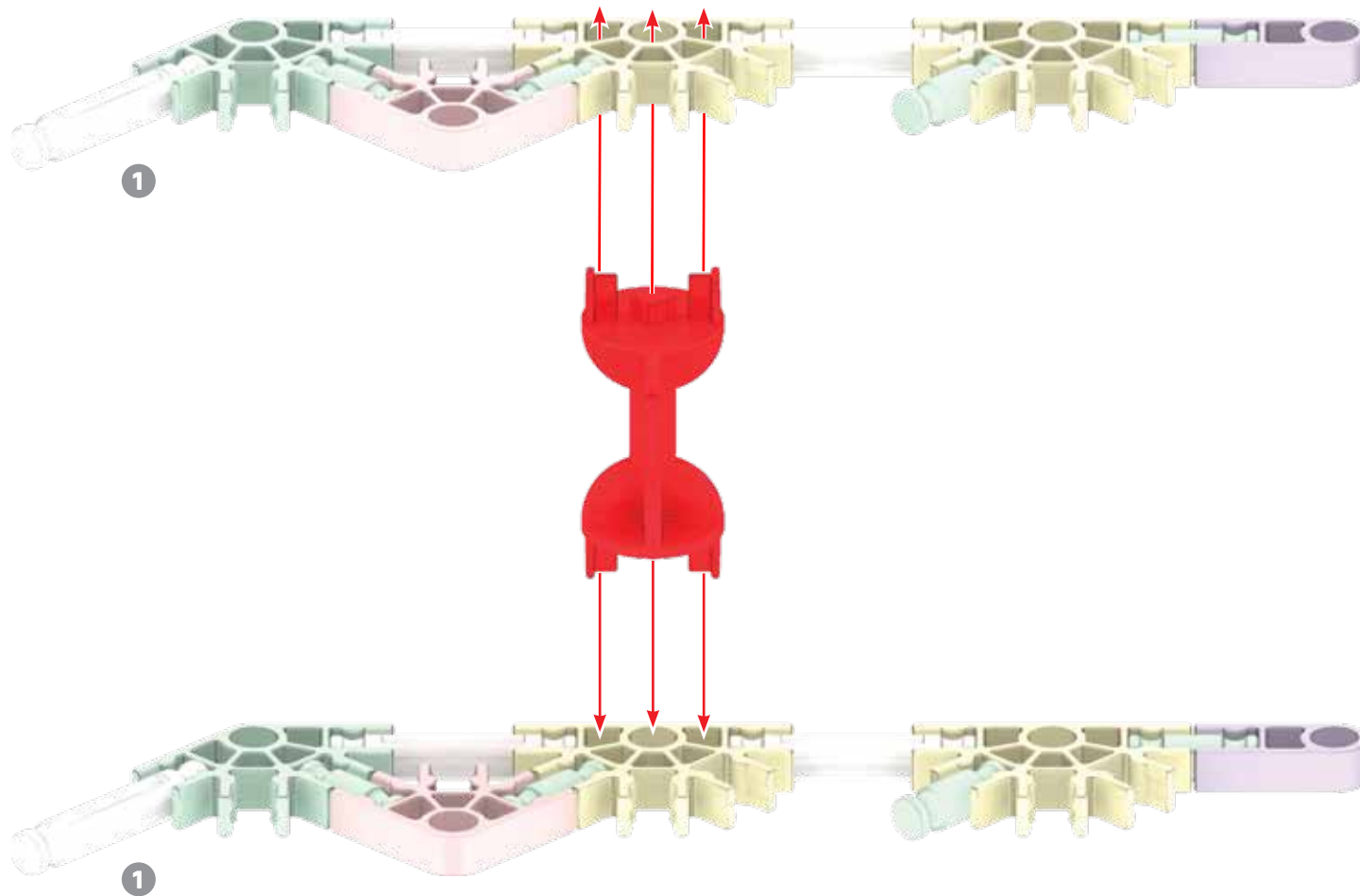

3

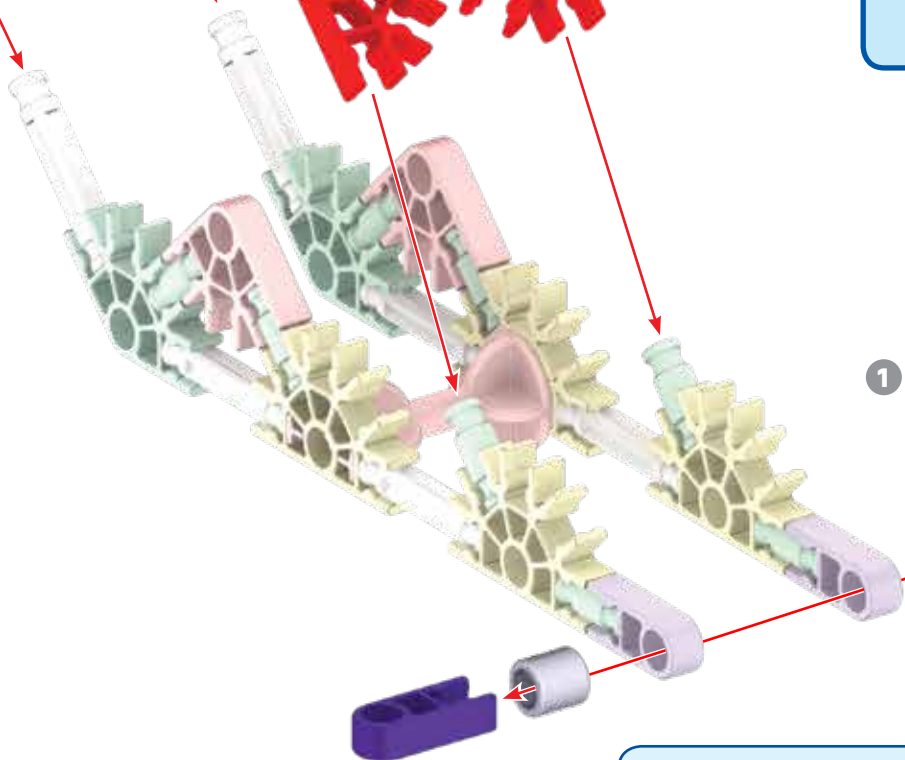
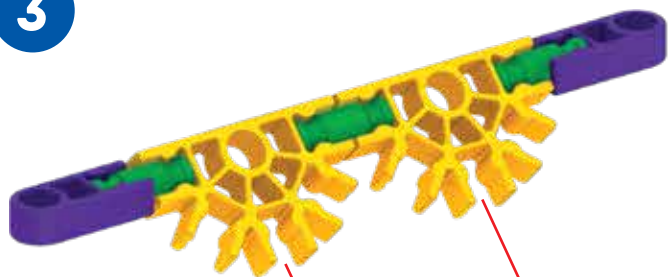

1 - 3

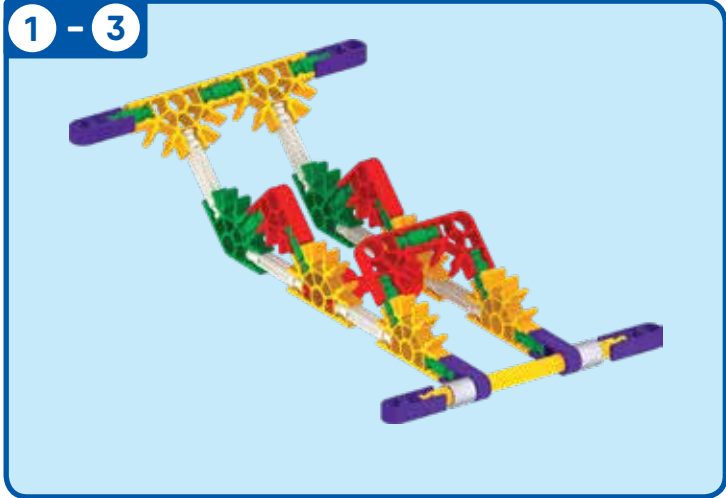

1 - 2



4

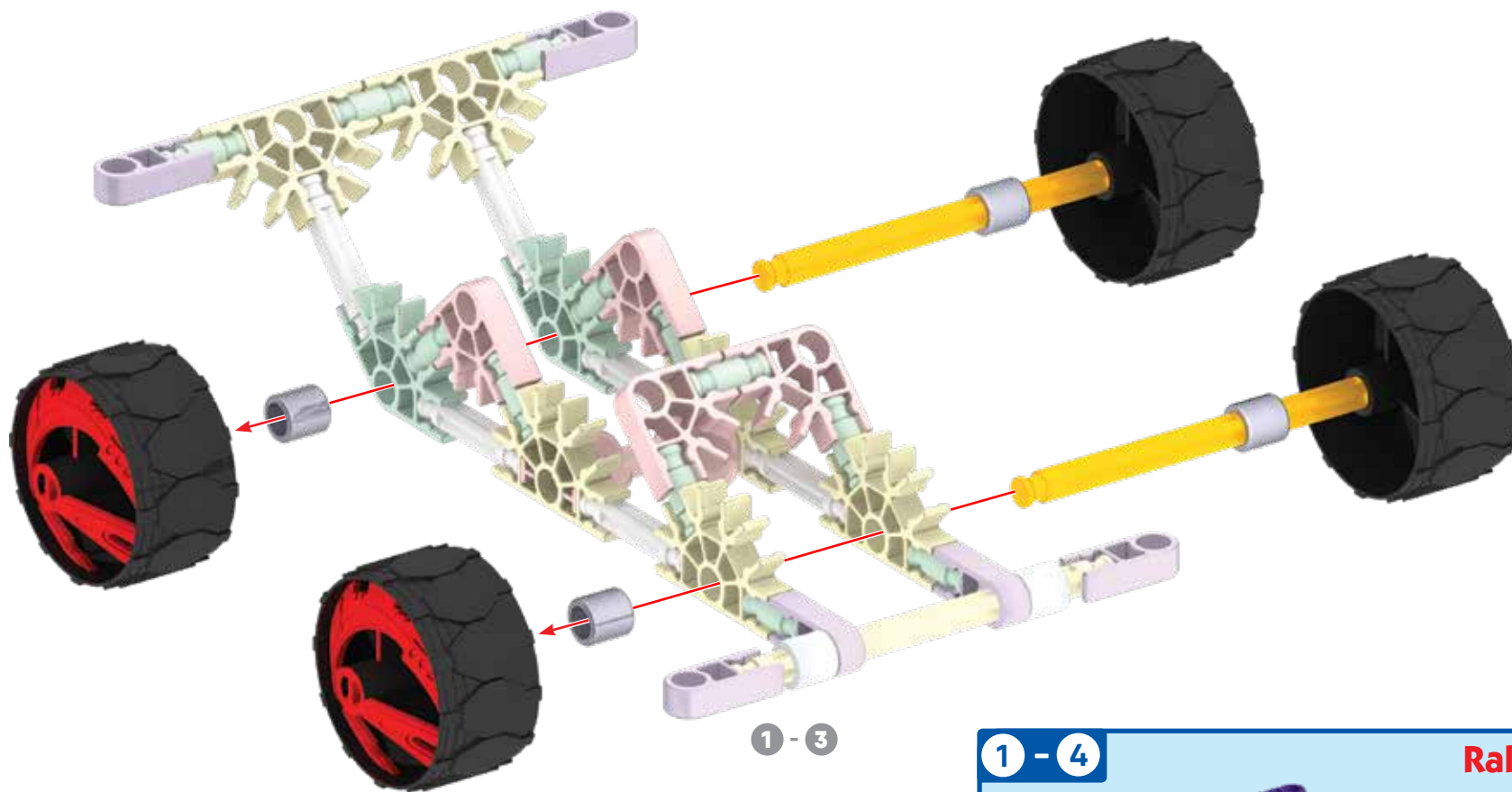

1 - 3

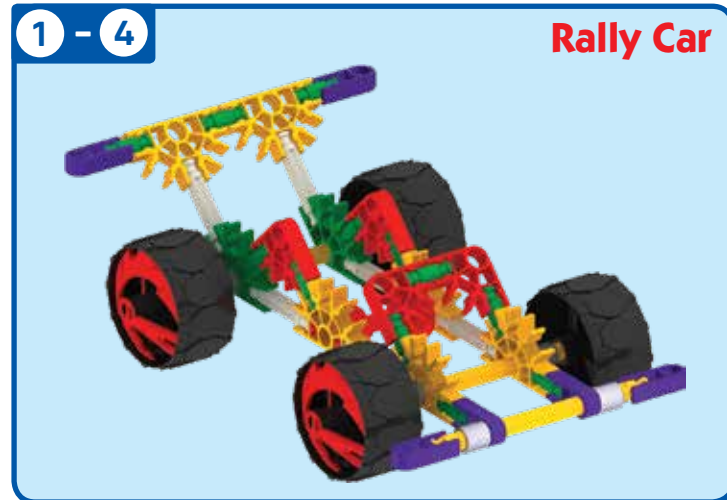

Rally Car

River Boat

1

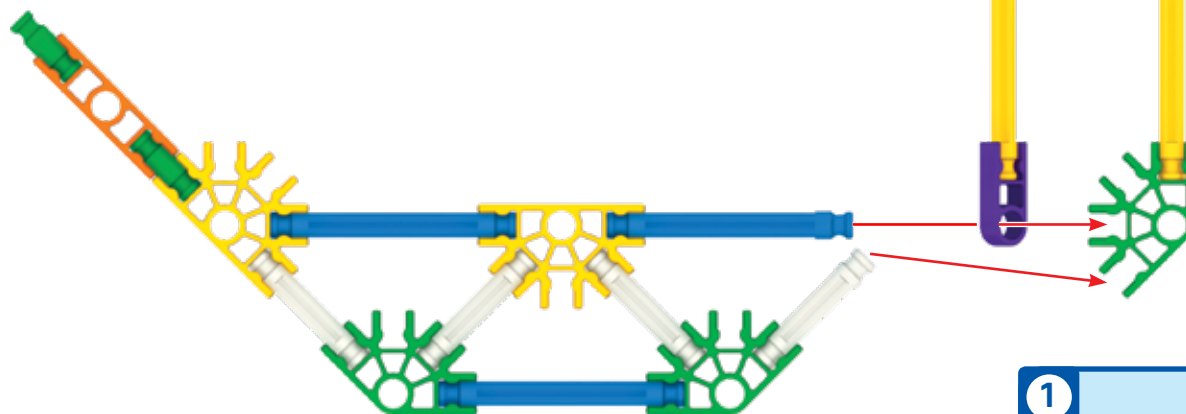
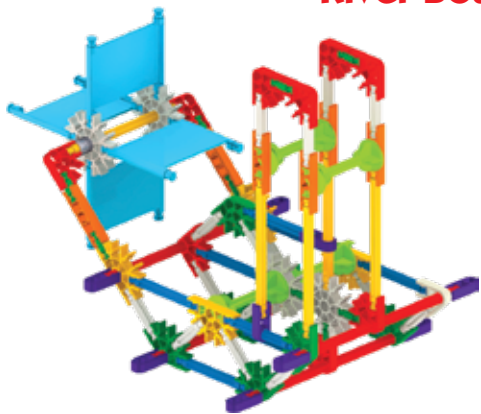

- 2 Yellow gear
- 3 Green connector
- 2 Red frame
- 3 Orange beam
- 1 Purple connector
- 3 Green connector
- 6 White axle
- 3 Blue beam
- 2 Yellow beam

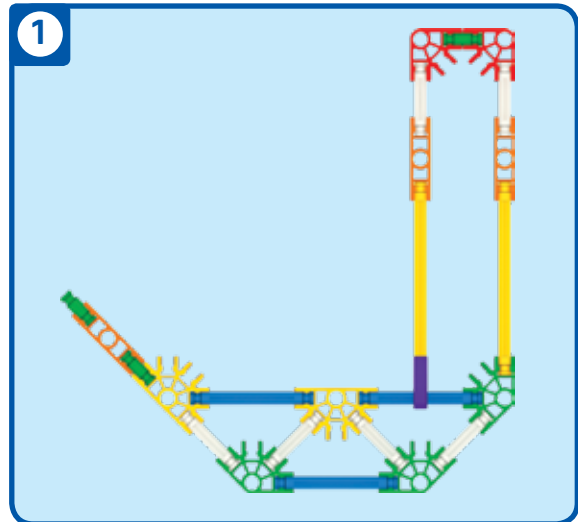

2

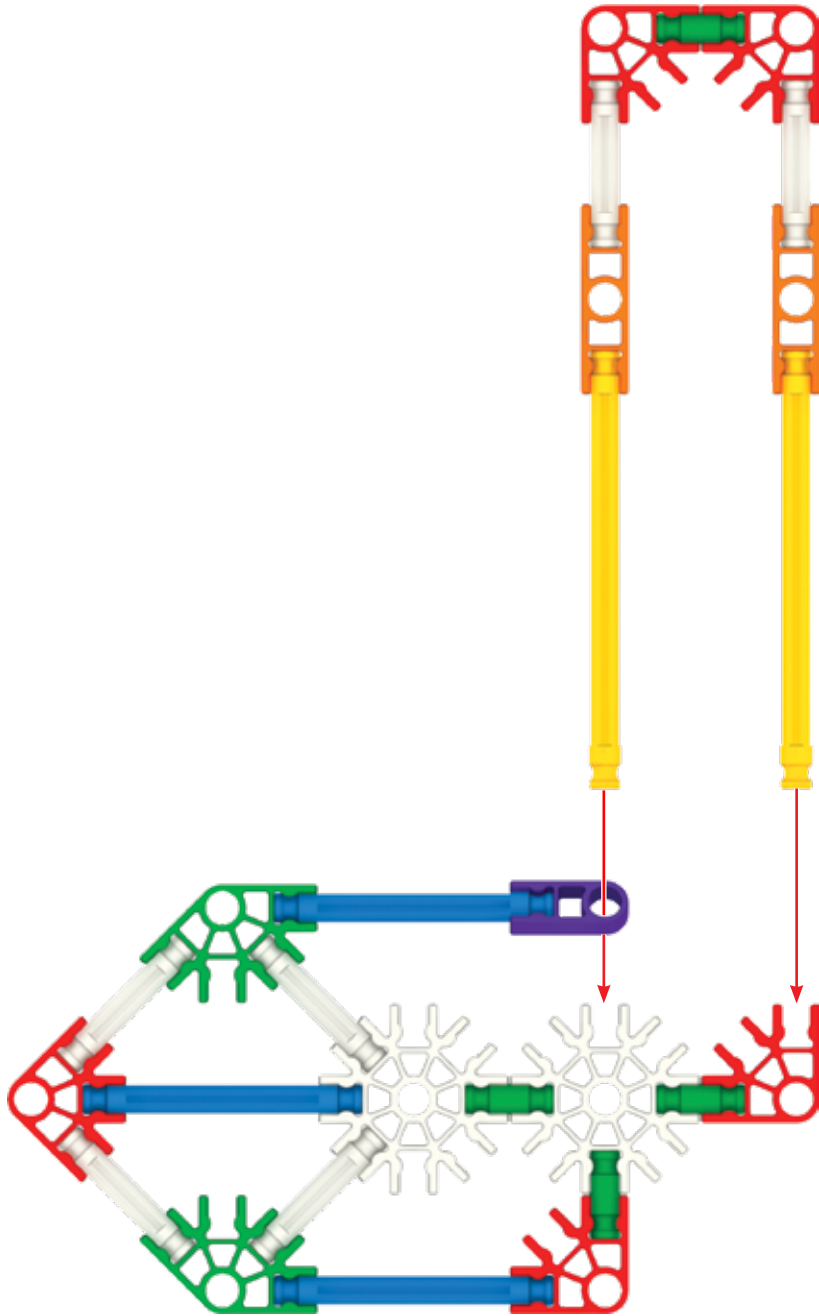

2		2		5		2	
1		4		6		3	
2							

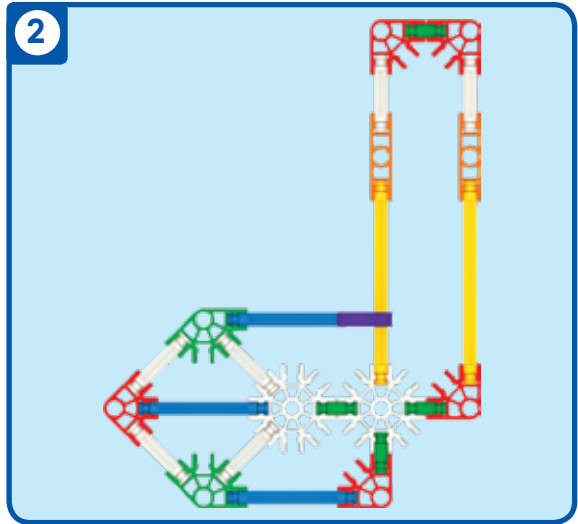

3

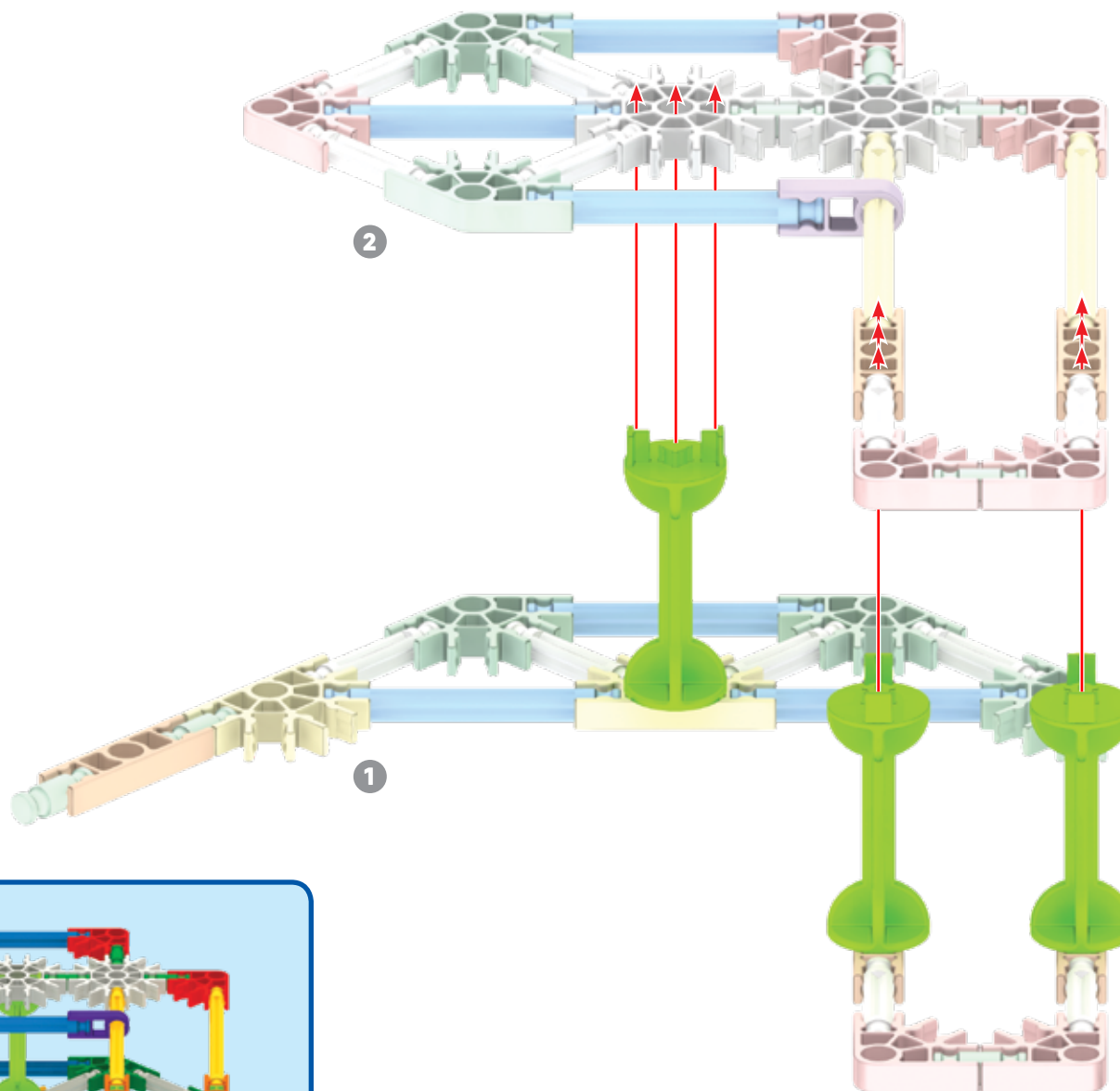

1 - 3

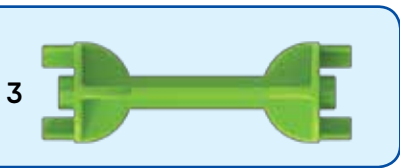

4

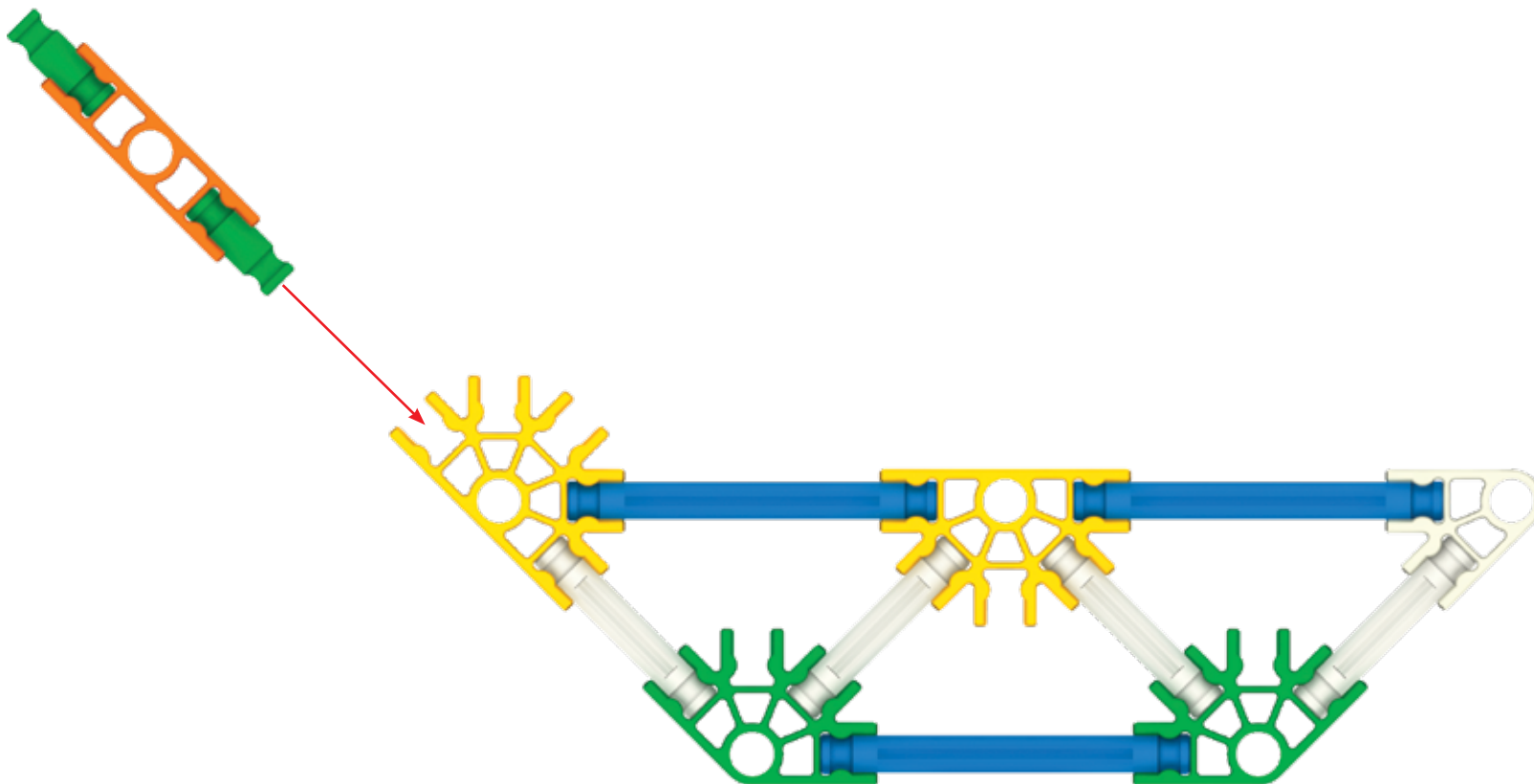

4

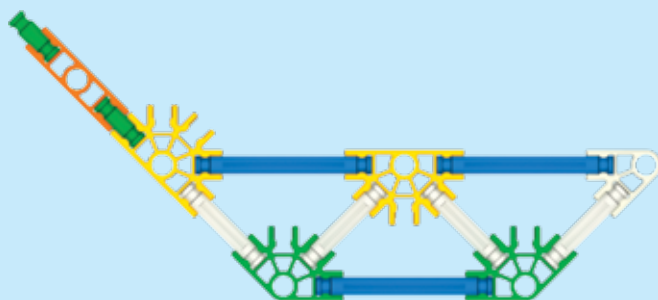

- | | | | | | | | |
|---|--|---|--|---|--|---|--|
| 2 | | 2 | | 1 | | 1 | |
| 2 | | 4 | | 3 | | | |

5

4

2

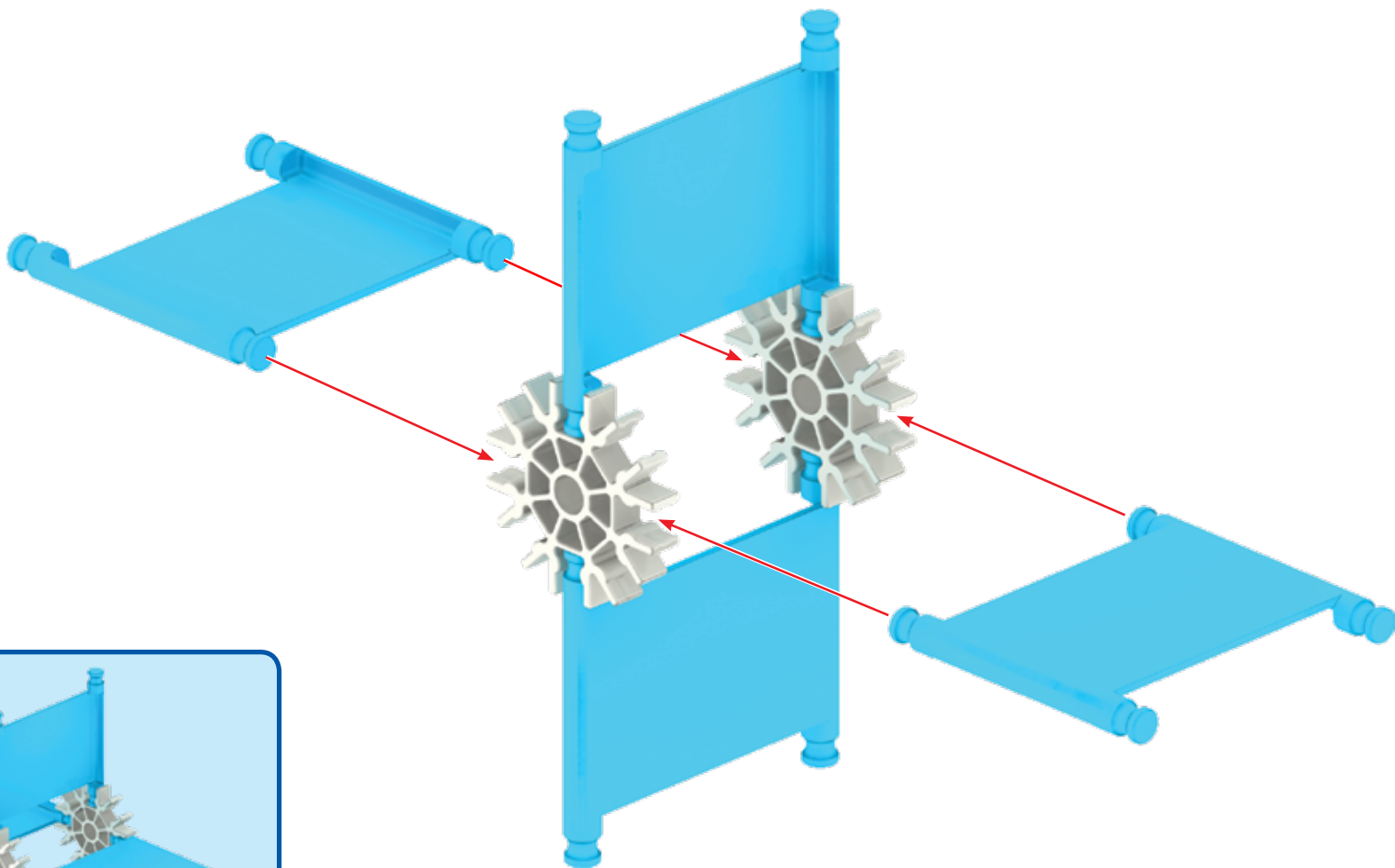

5

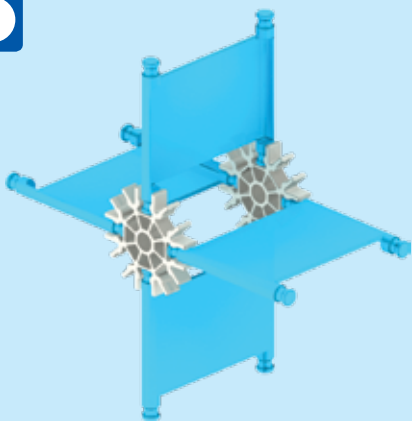

6

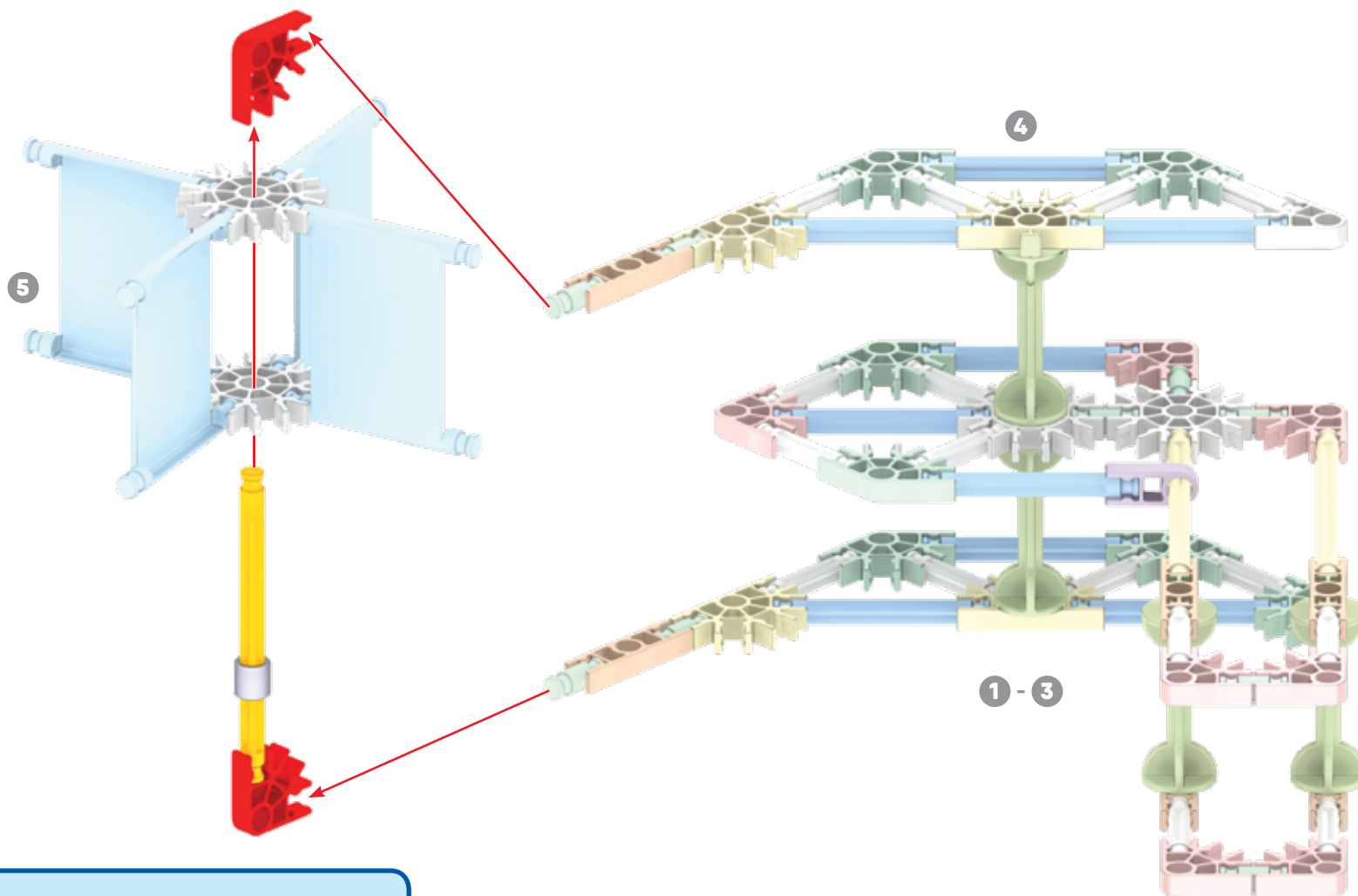

1 - 6

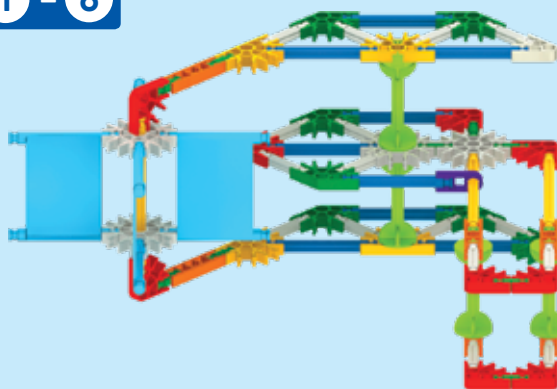

7

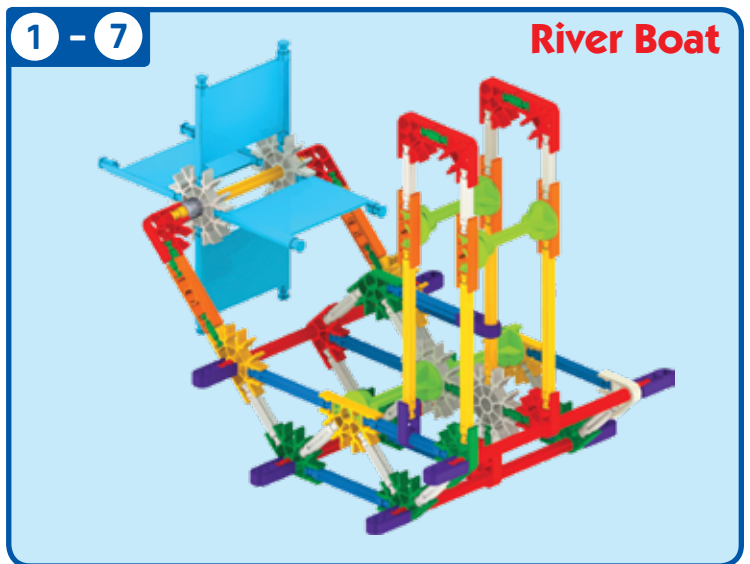
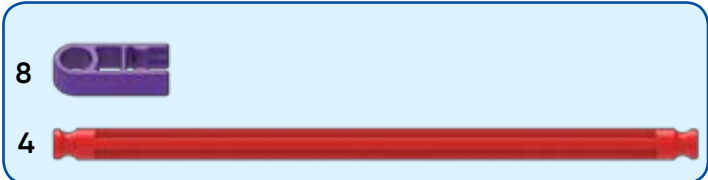
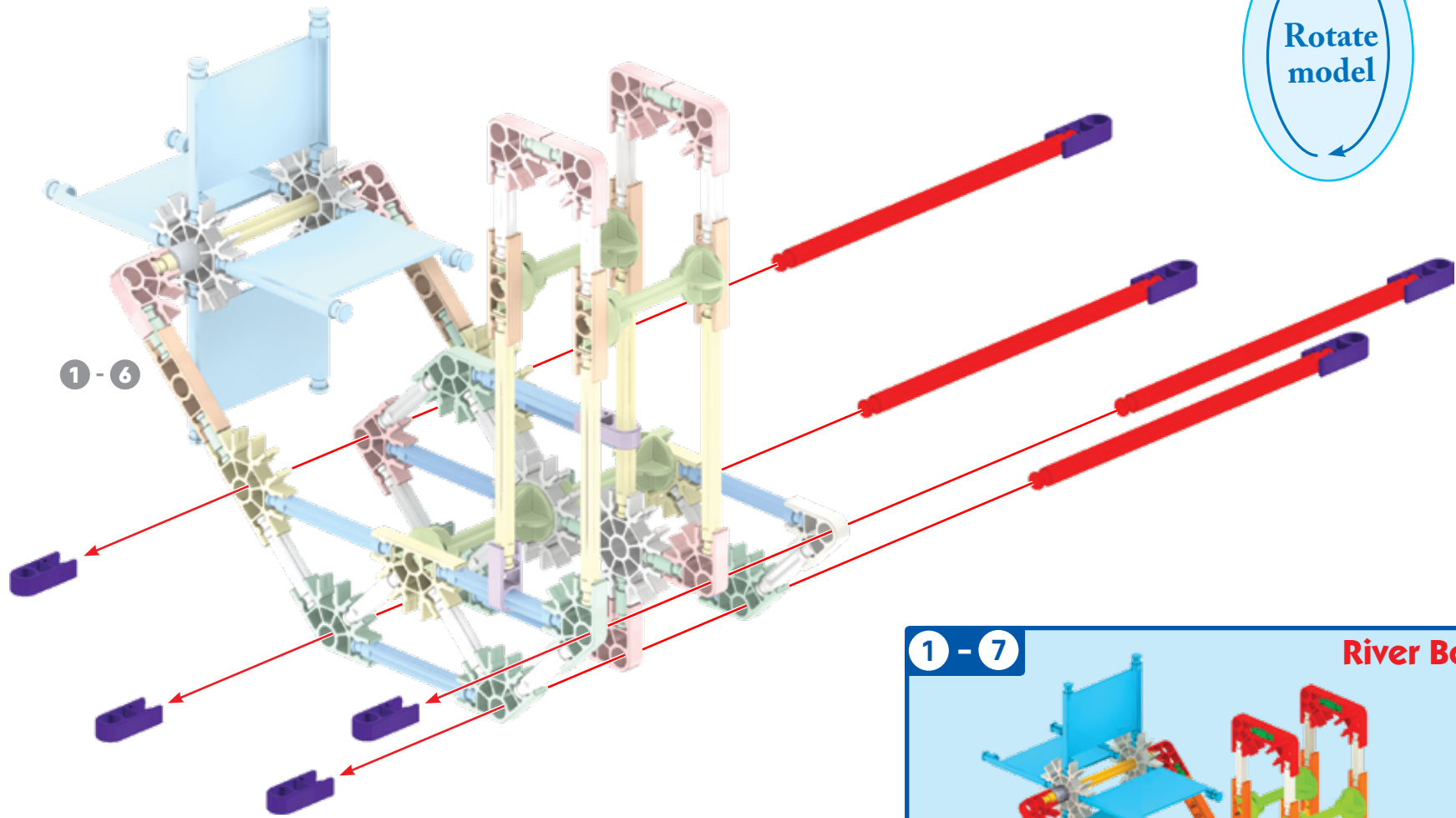
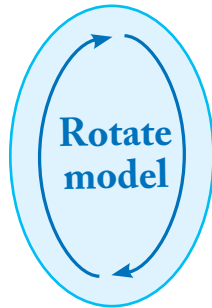

1

Row Boat

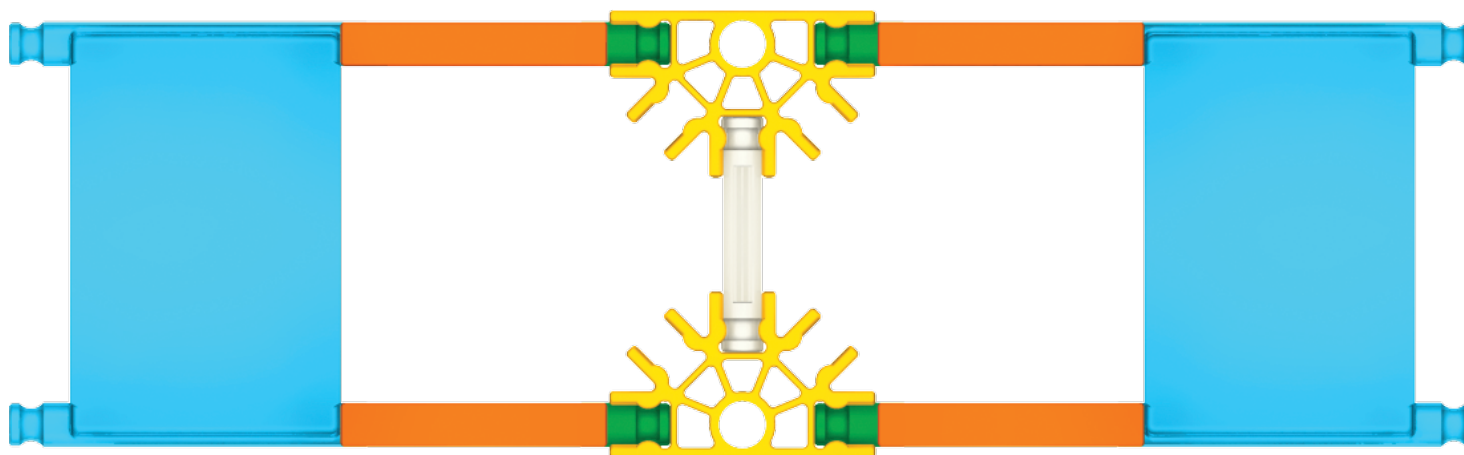

1

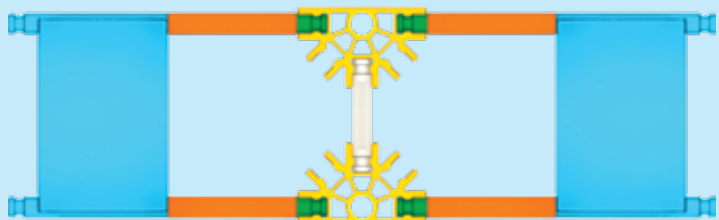

2



2



4



4



1

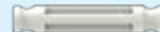

2

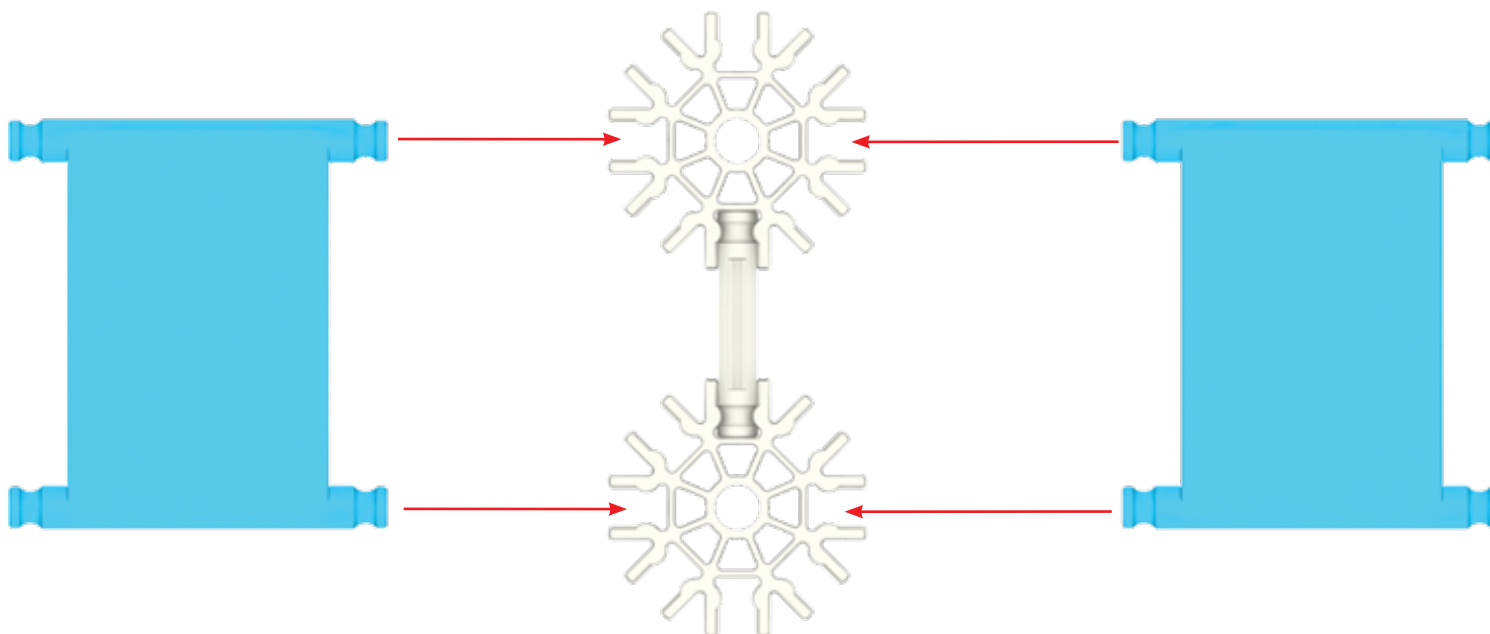

2

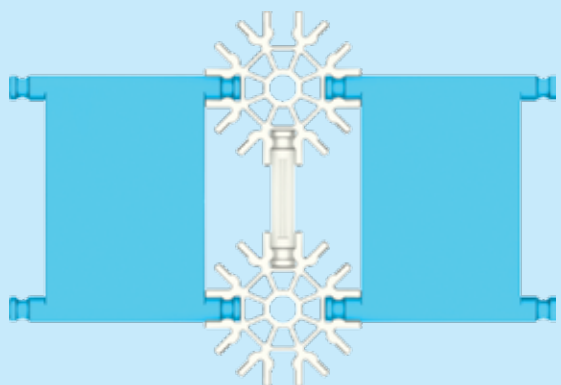

2



2

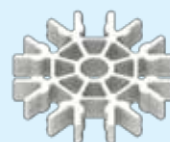

1



3

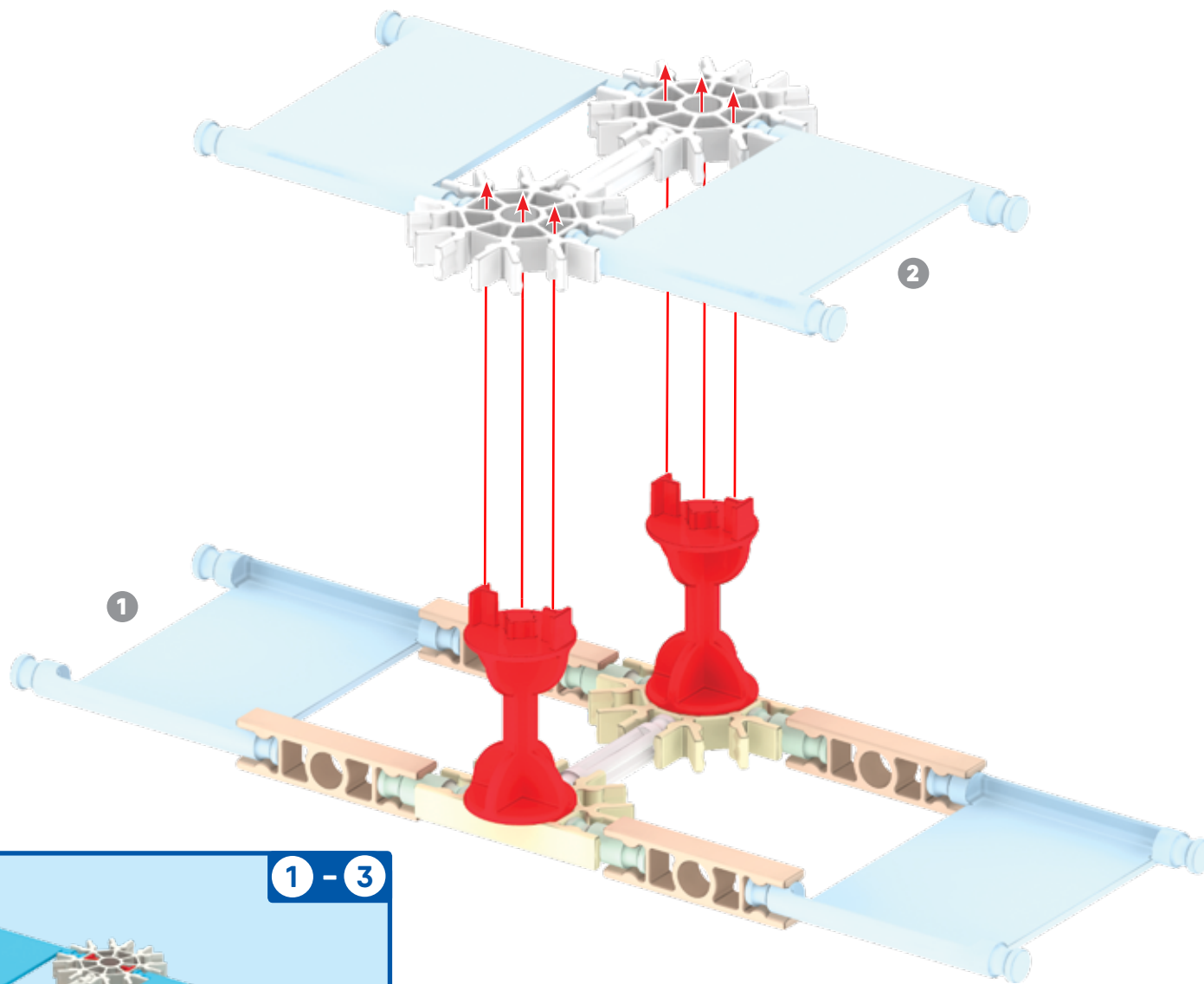

1 - 3

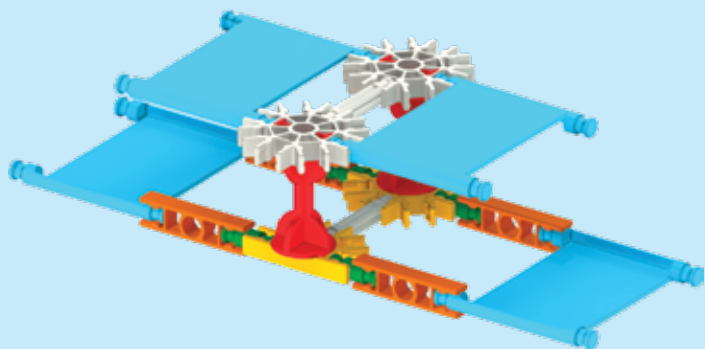

2

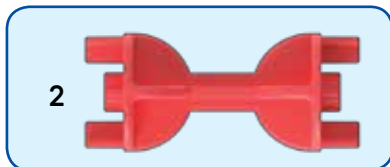

4

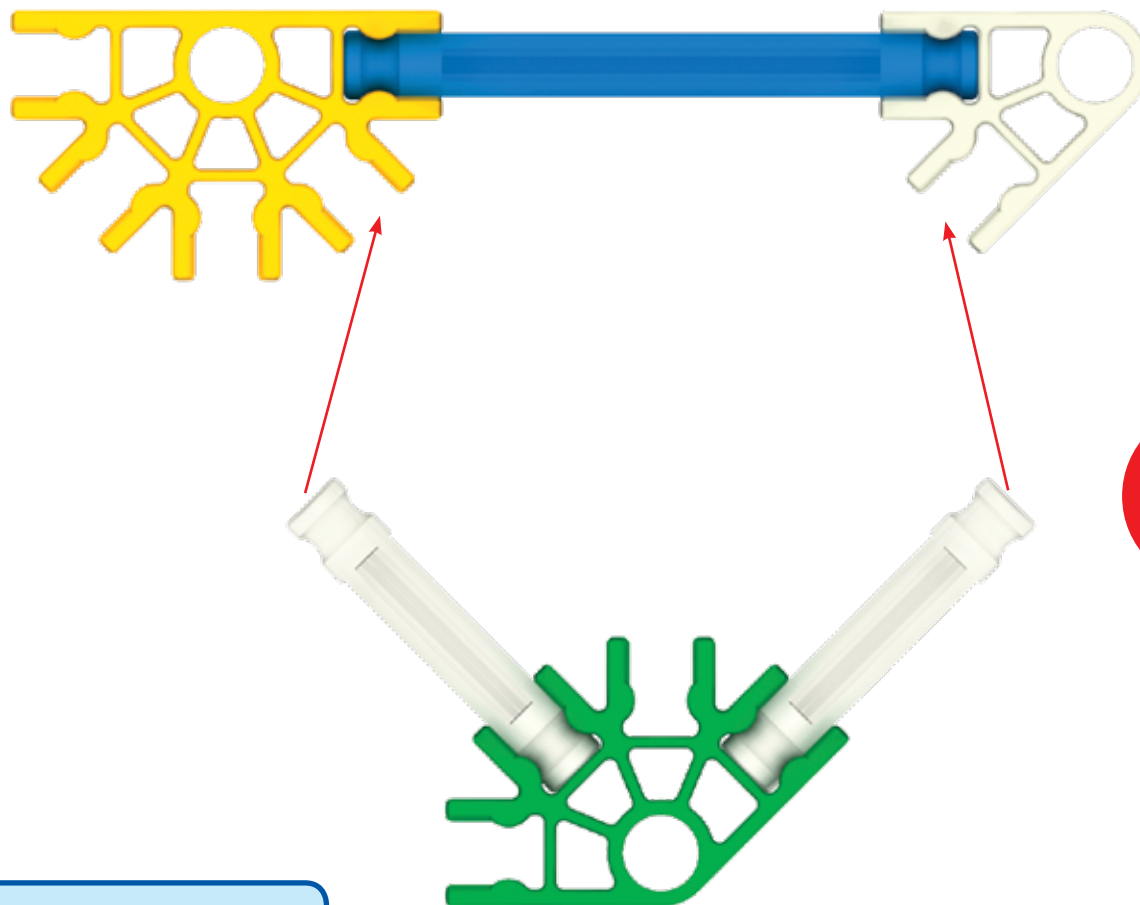

4

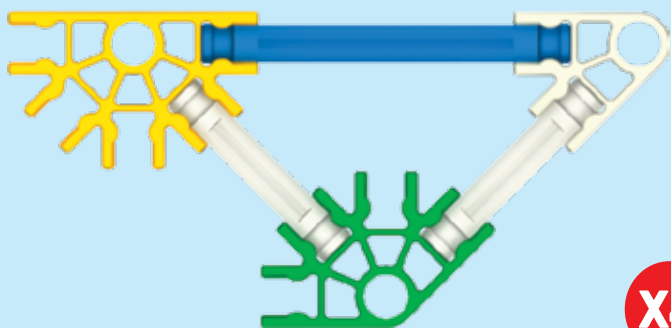

X4

4



4



4



8



4



5

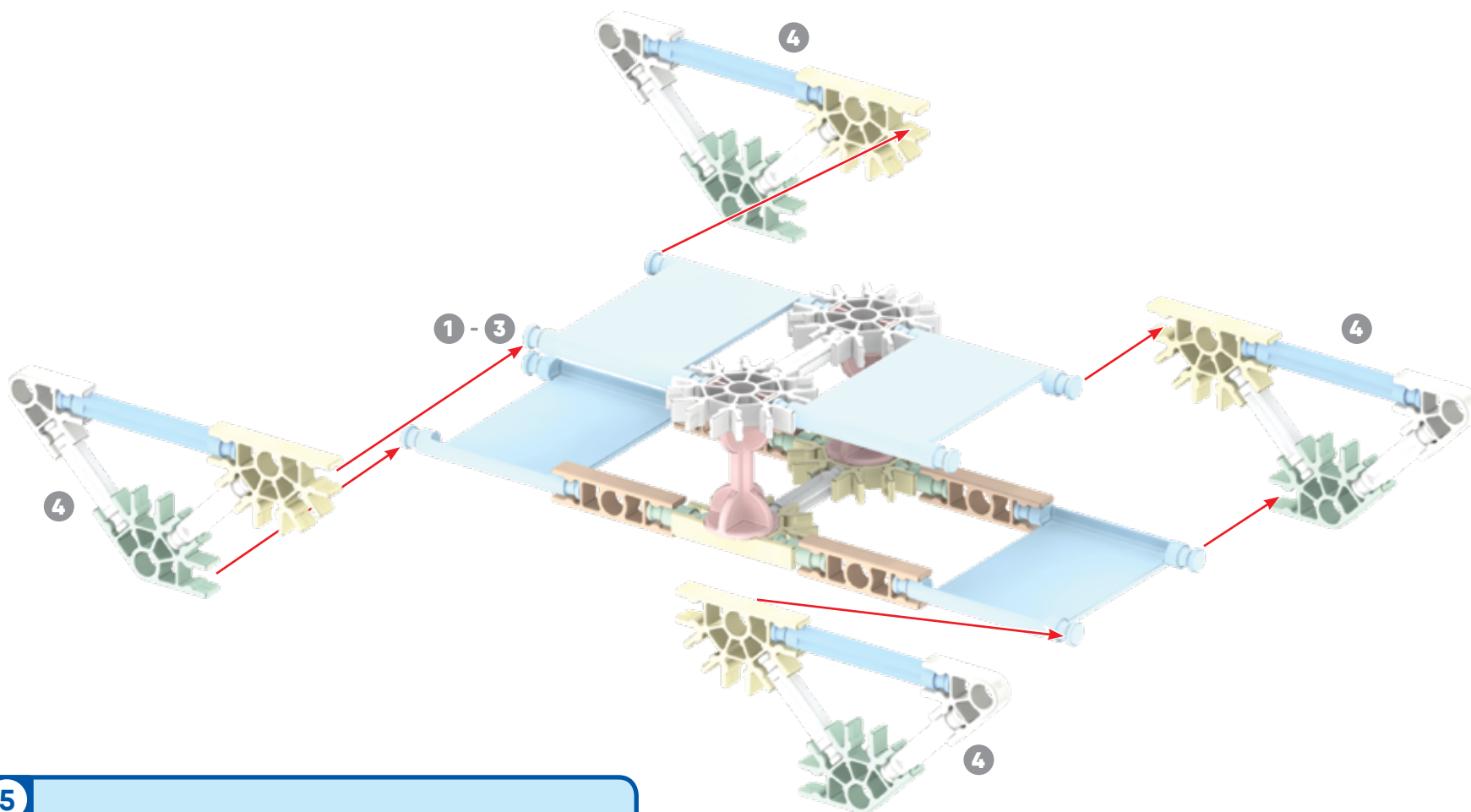

1 - 5

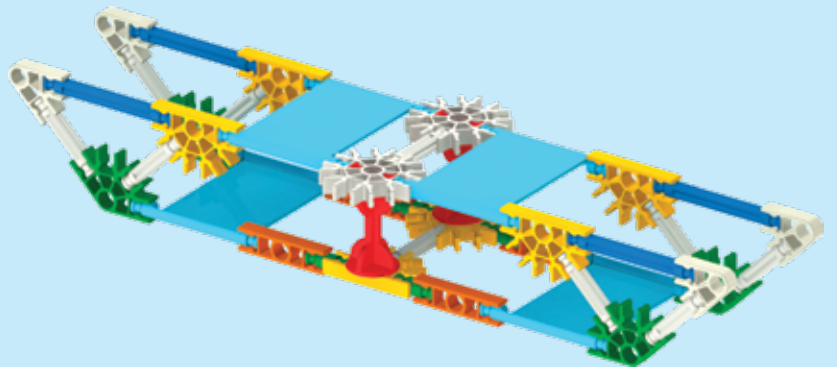

6

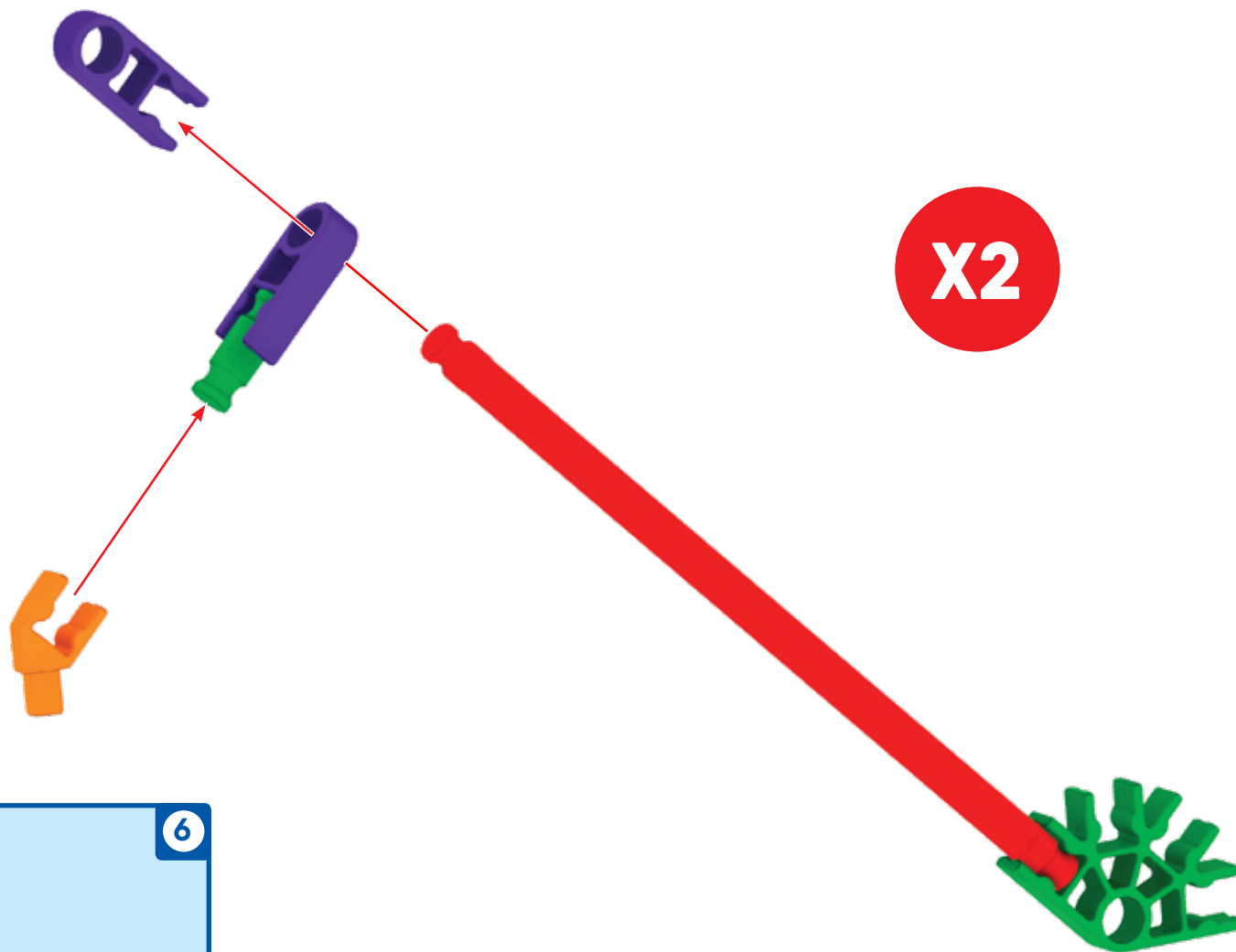

X2

6

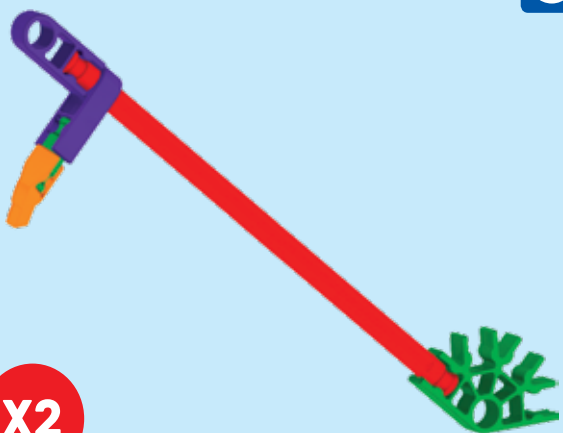

X2

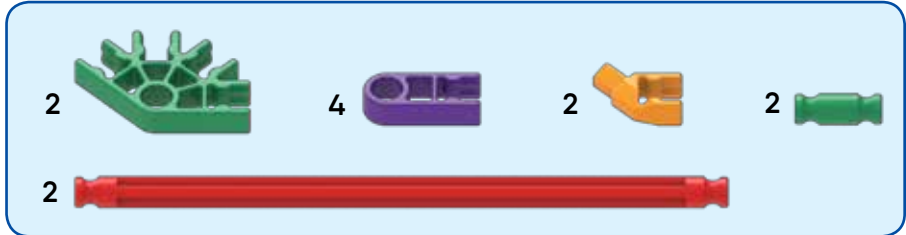

7

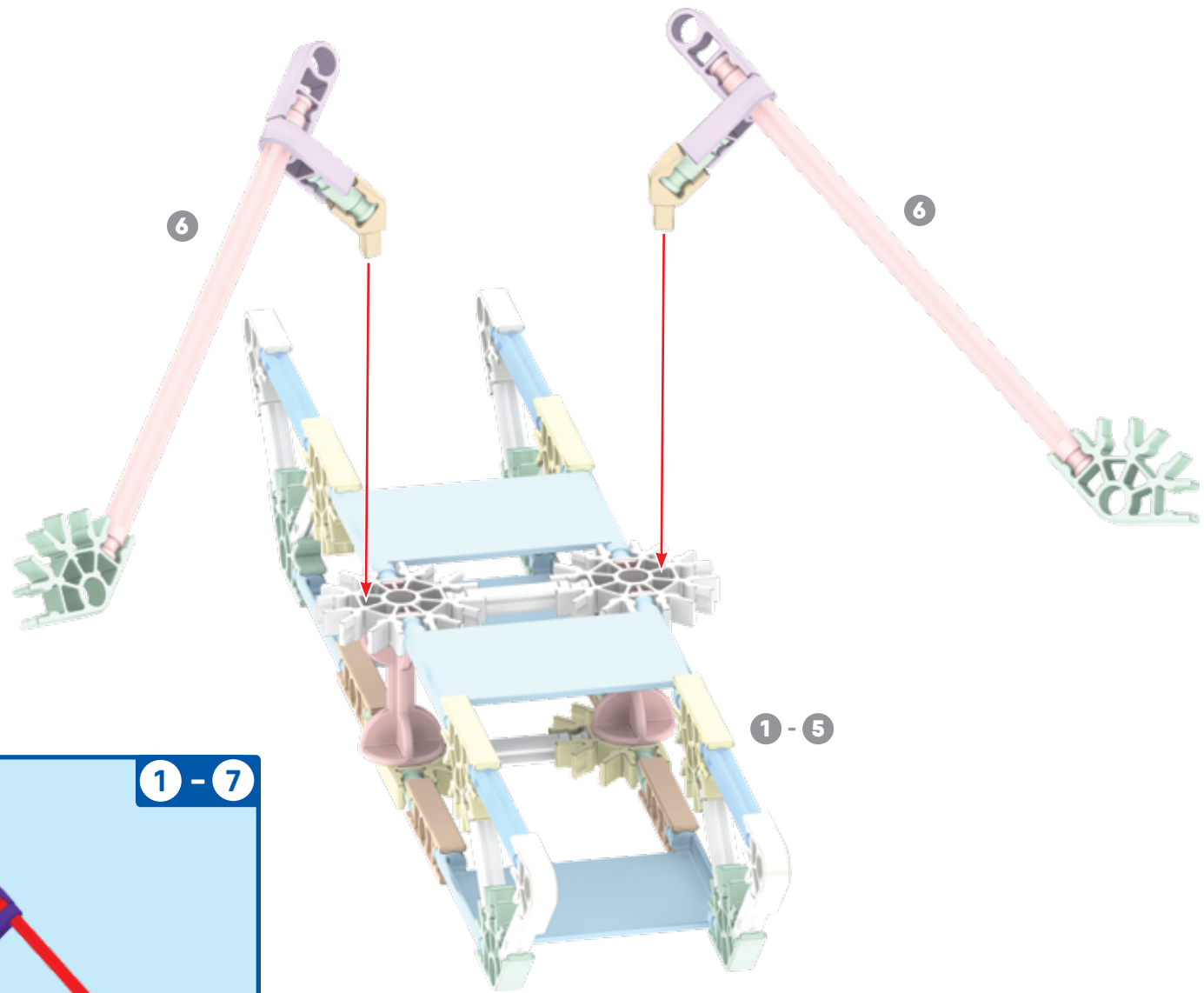

Row Boat

1 - 7

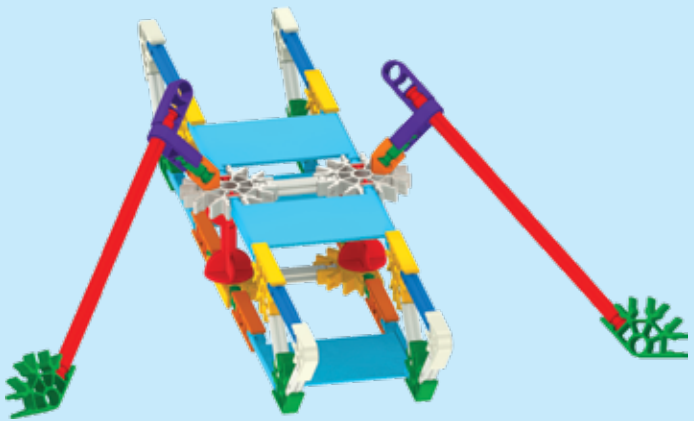

1

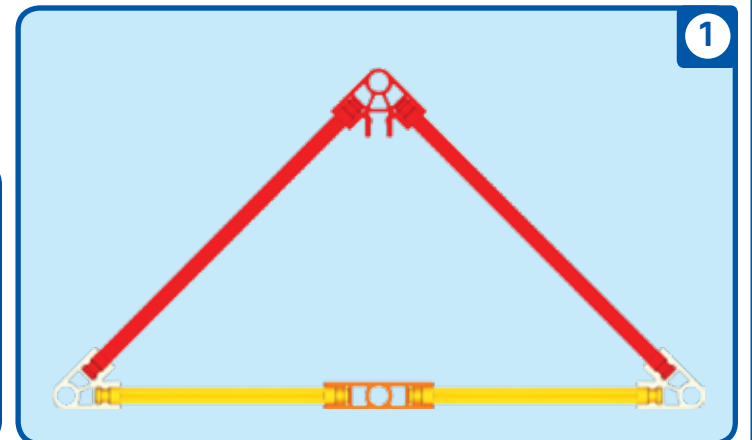
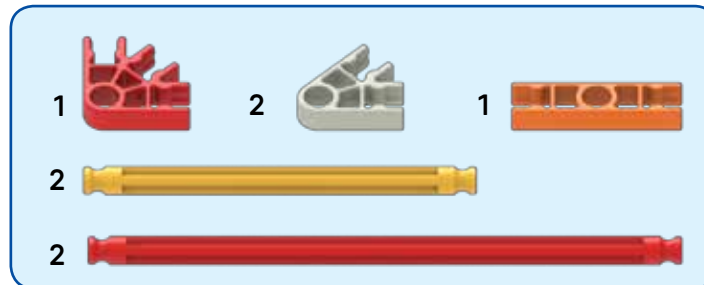
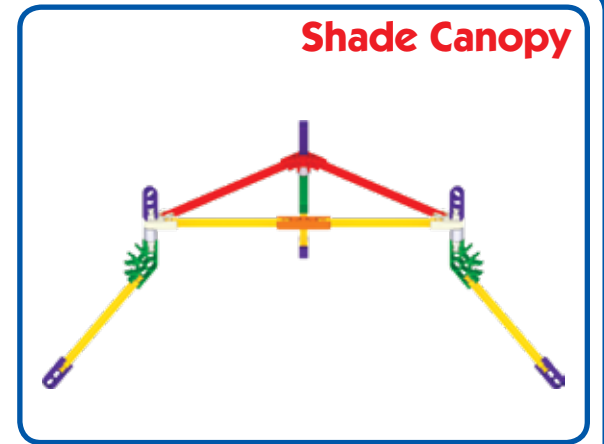
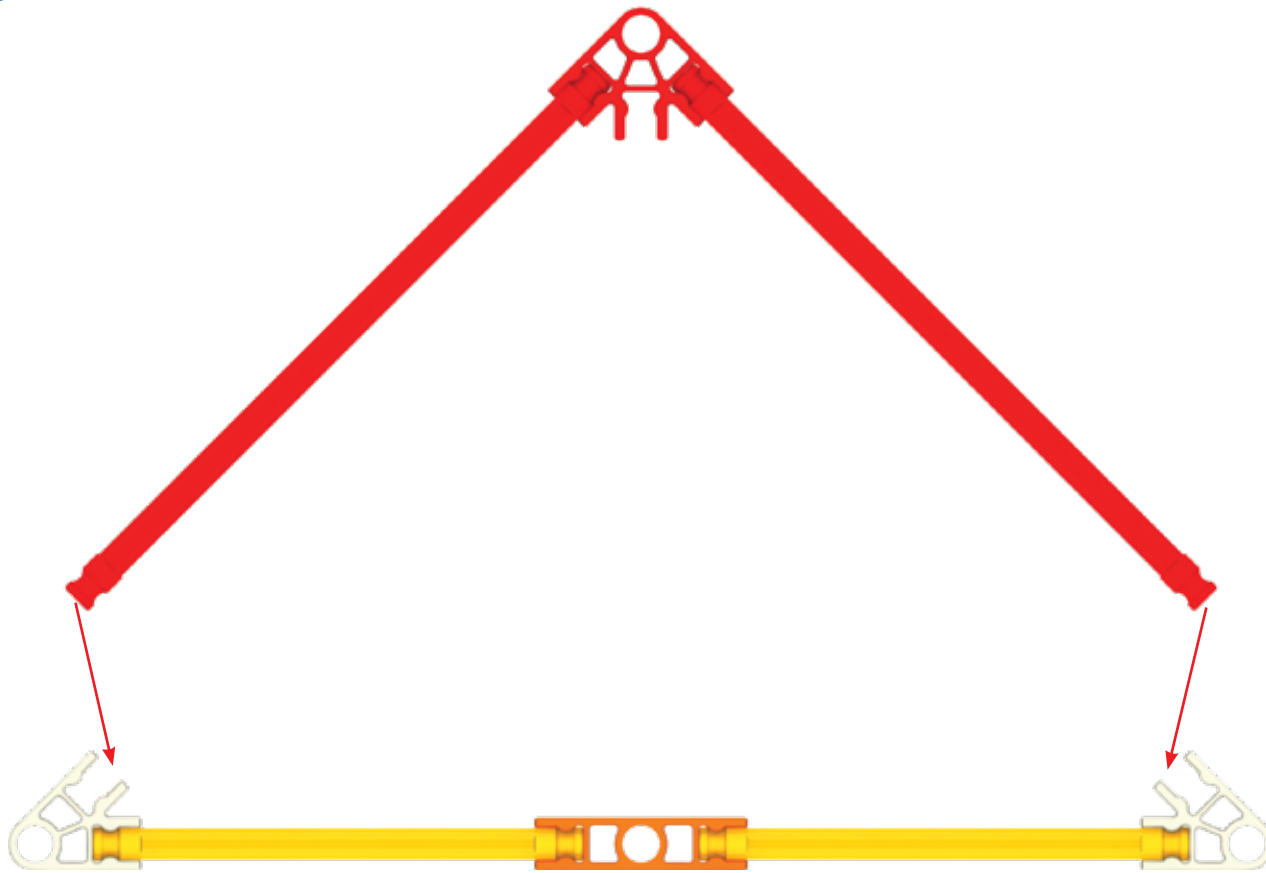

2

X3



3



3



3



3



2



X3



3

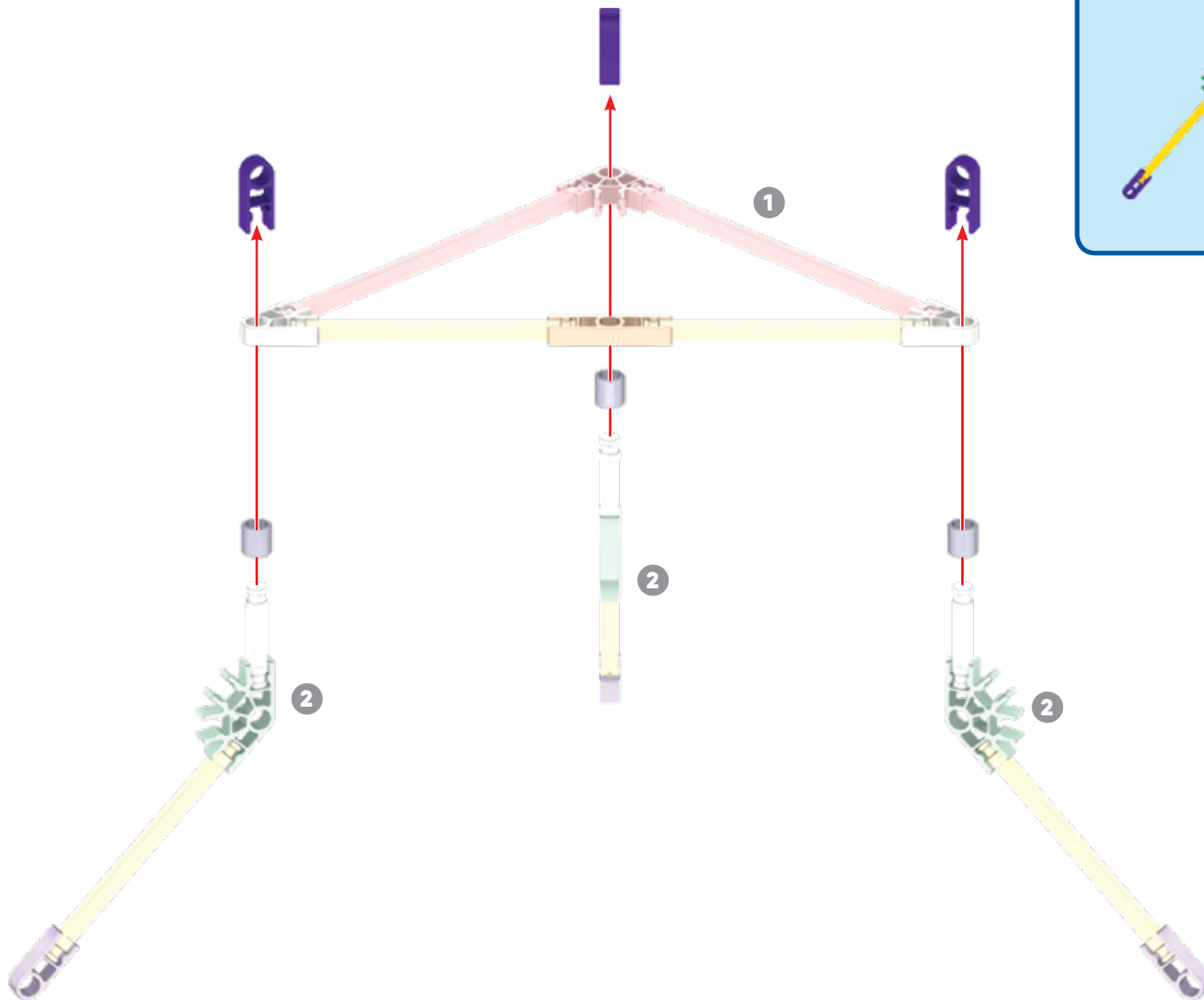

Shade Canopy

1 - 3

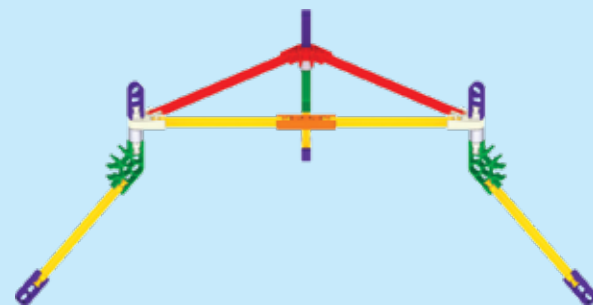

3



3



1

Stairway

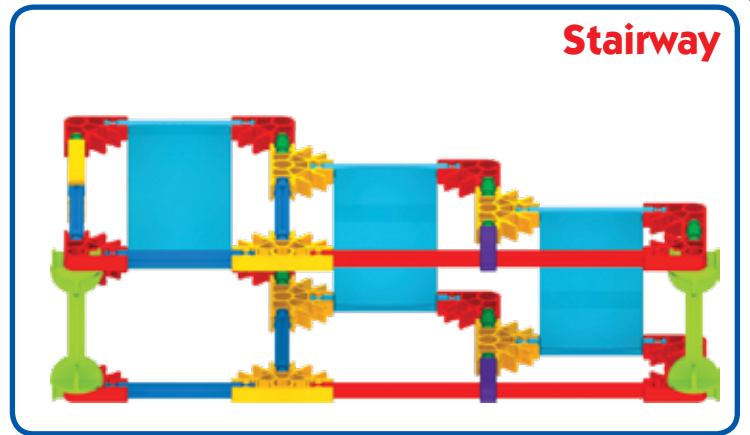



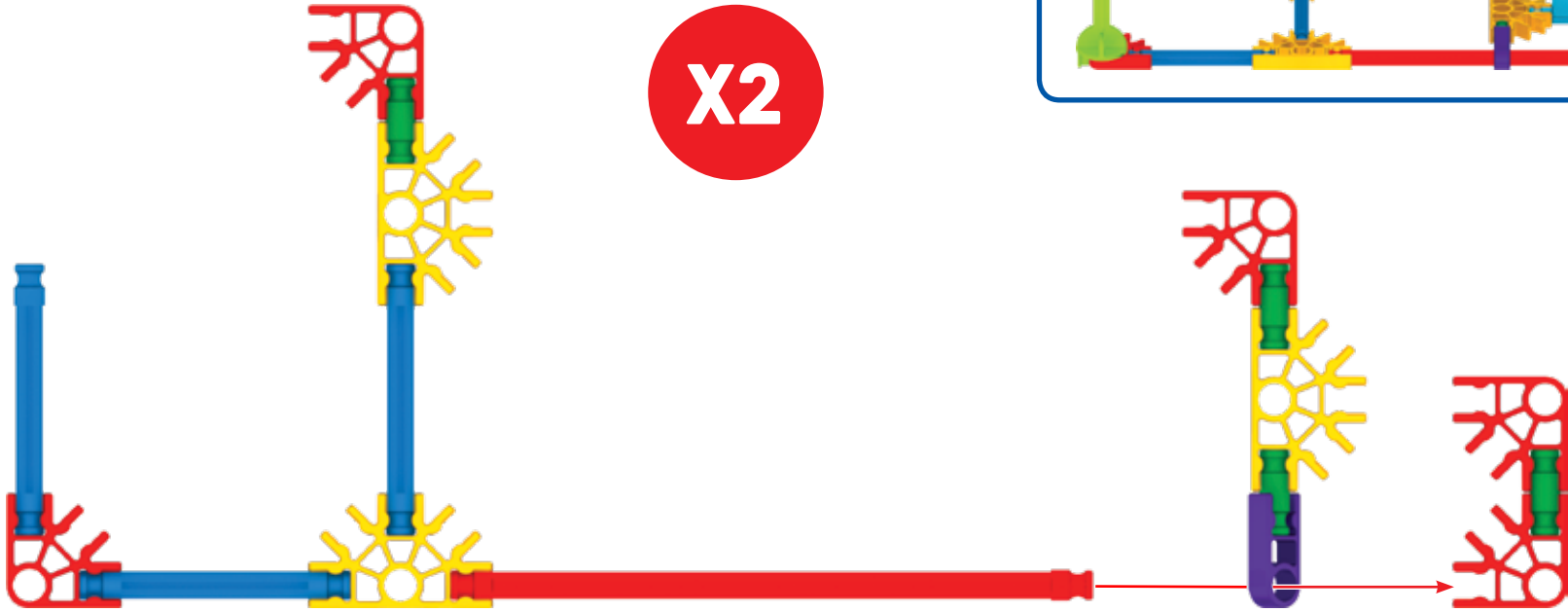



X2

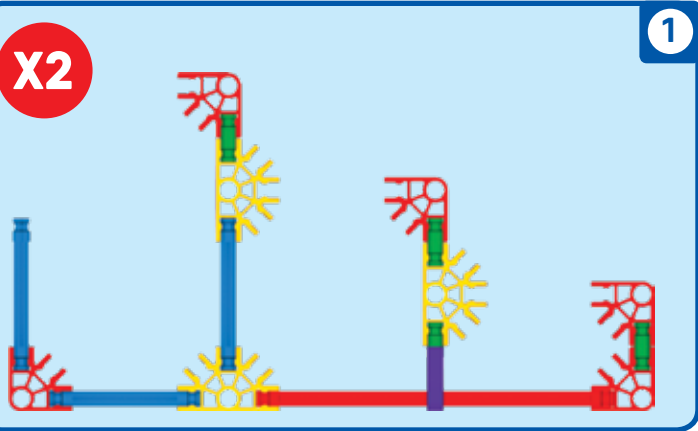

X2

1



- 6  10  2  8 
- 6  2 

2

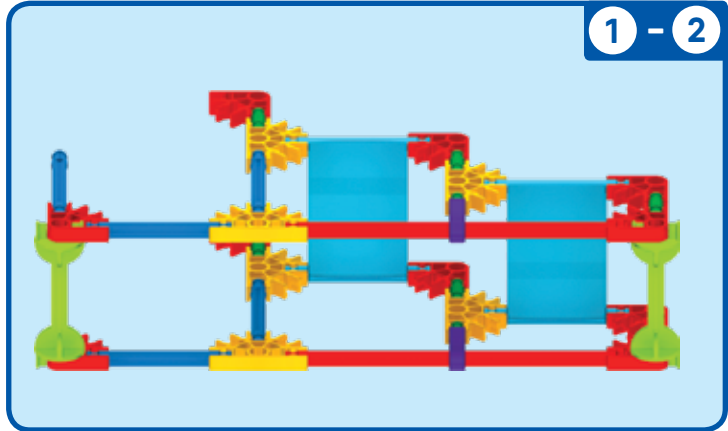
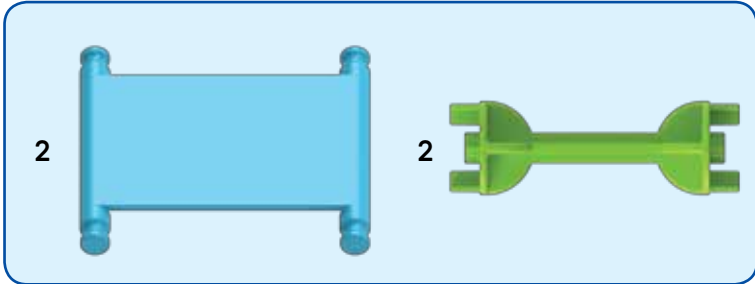
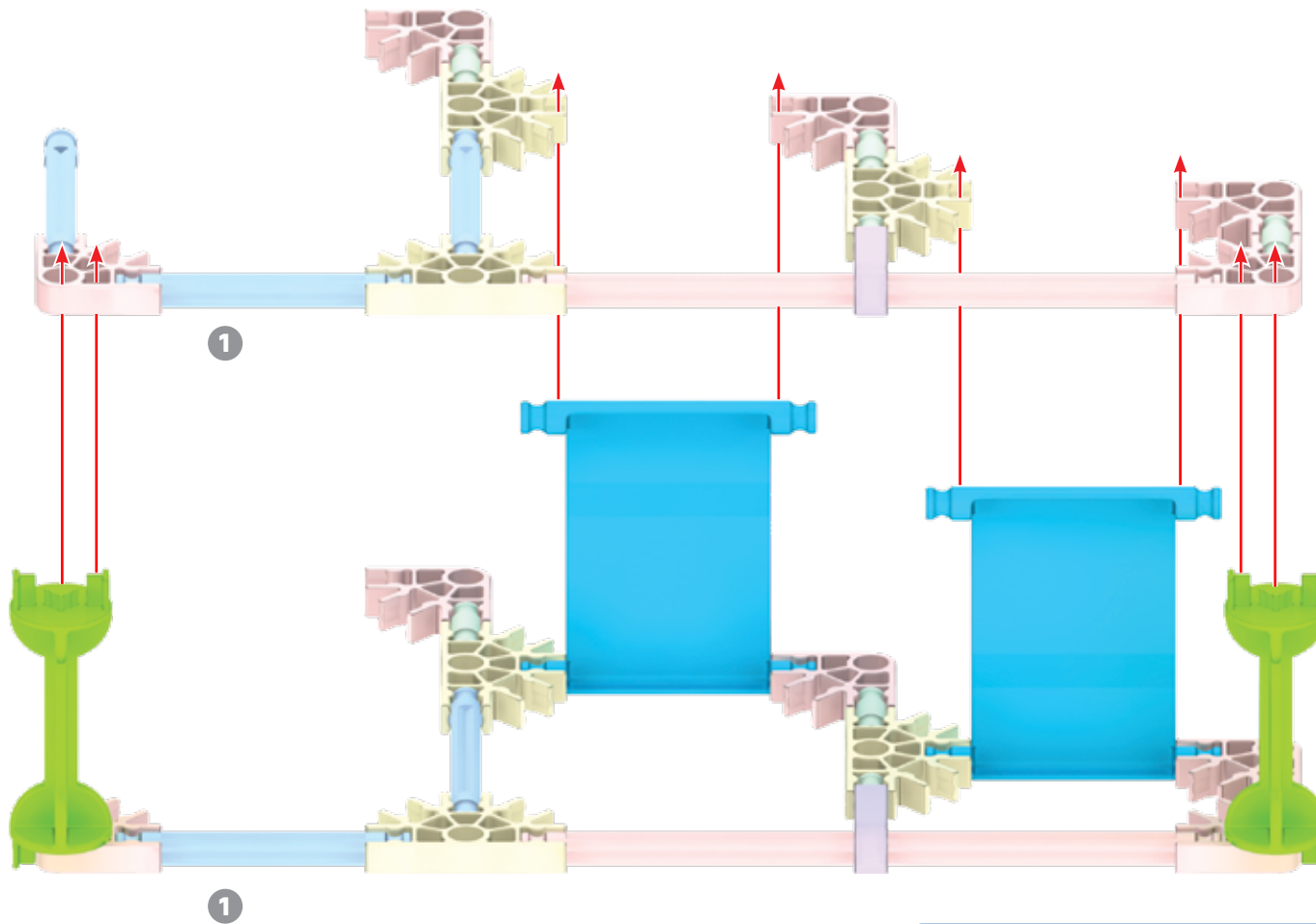

3

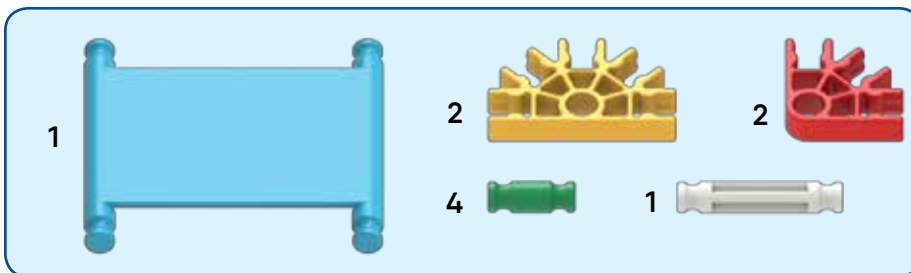
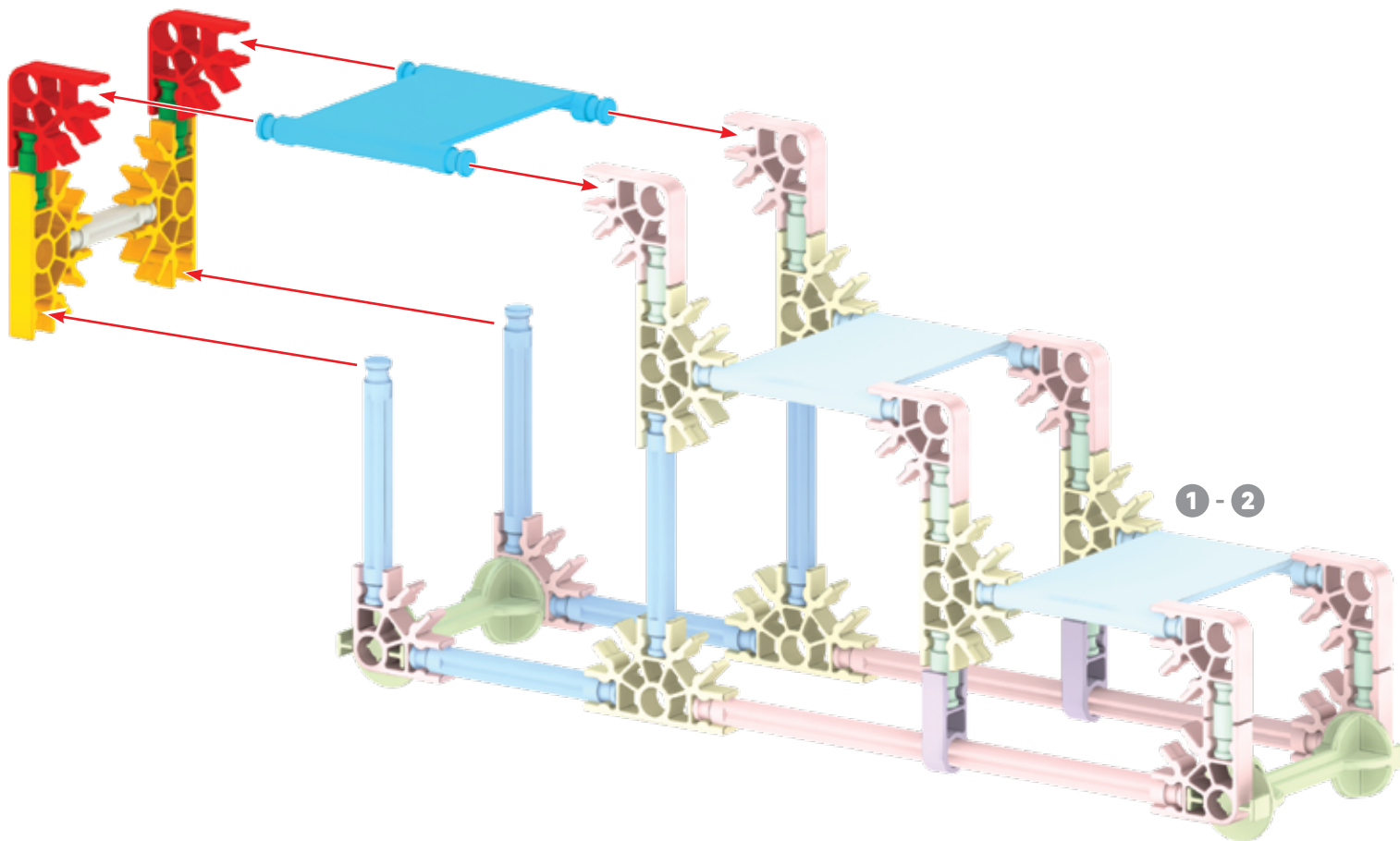

Stairway

1 - 3

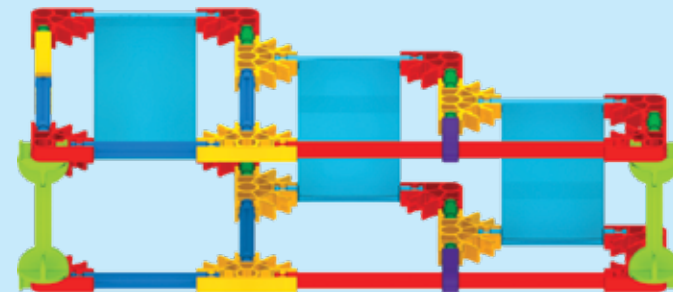

1

Stone Bridge

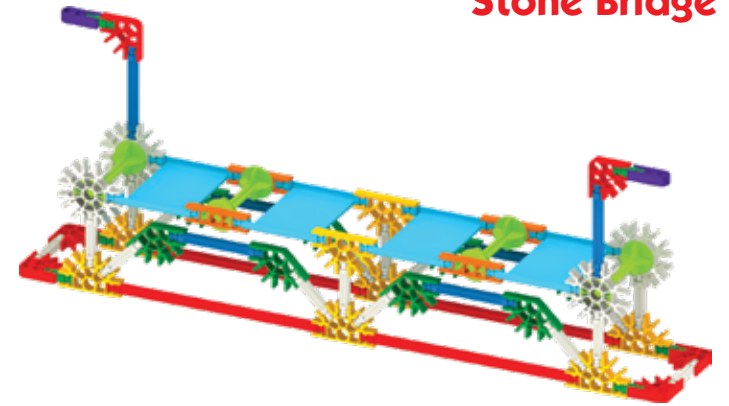

X2

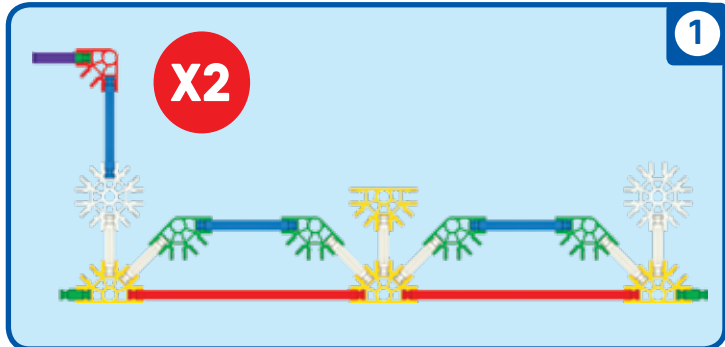
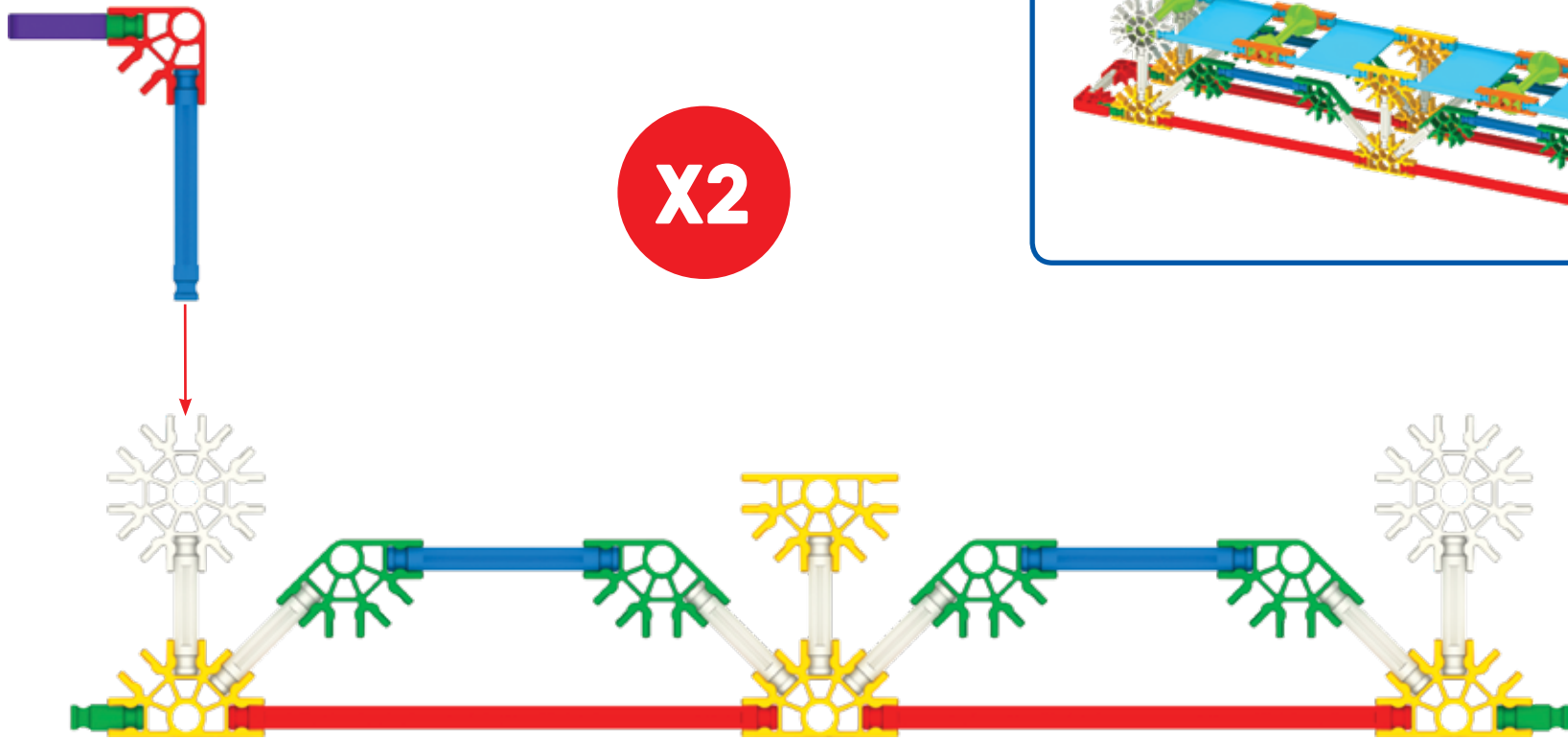

- | | | | | | | | |
|---|--|---|--|----|--|---|--|
| 4 | | 8 | | 8 | | 2 | |
| 2 | | 6 | | 14 | | 6 | |
| 4 | | | | | | | |

2

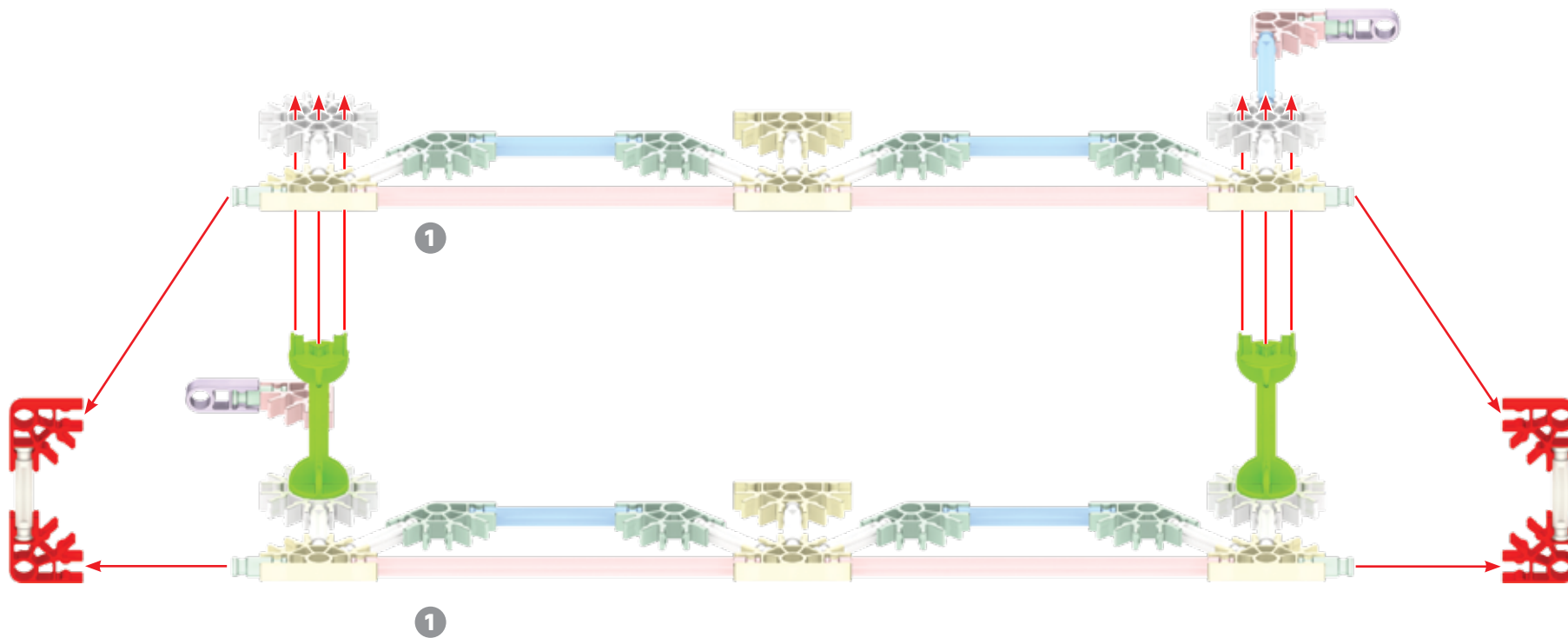

1 - 2

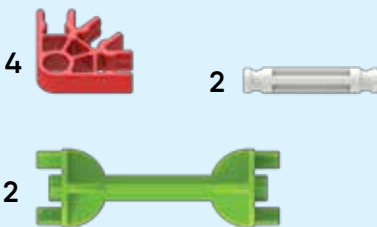
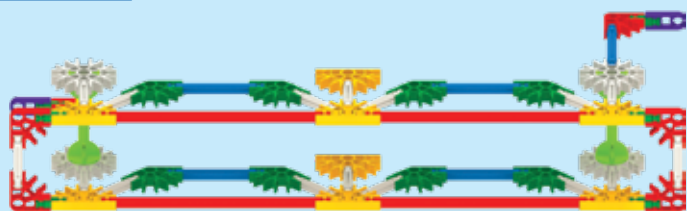

3

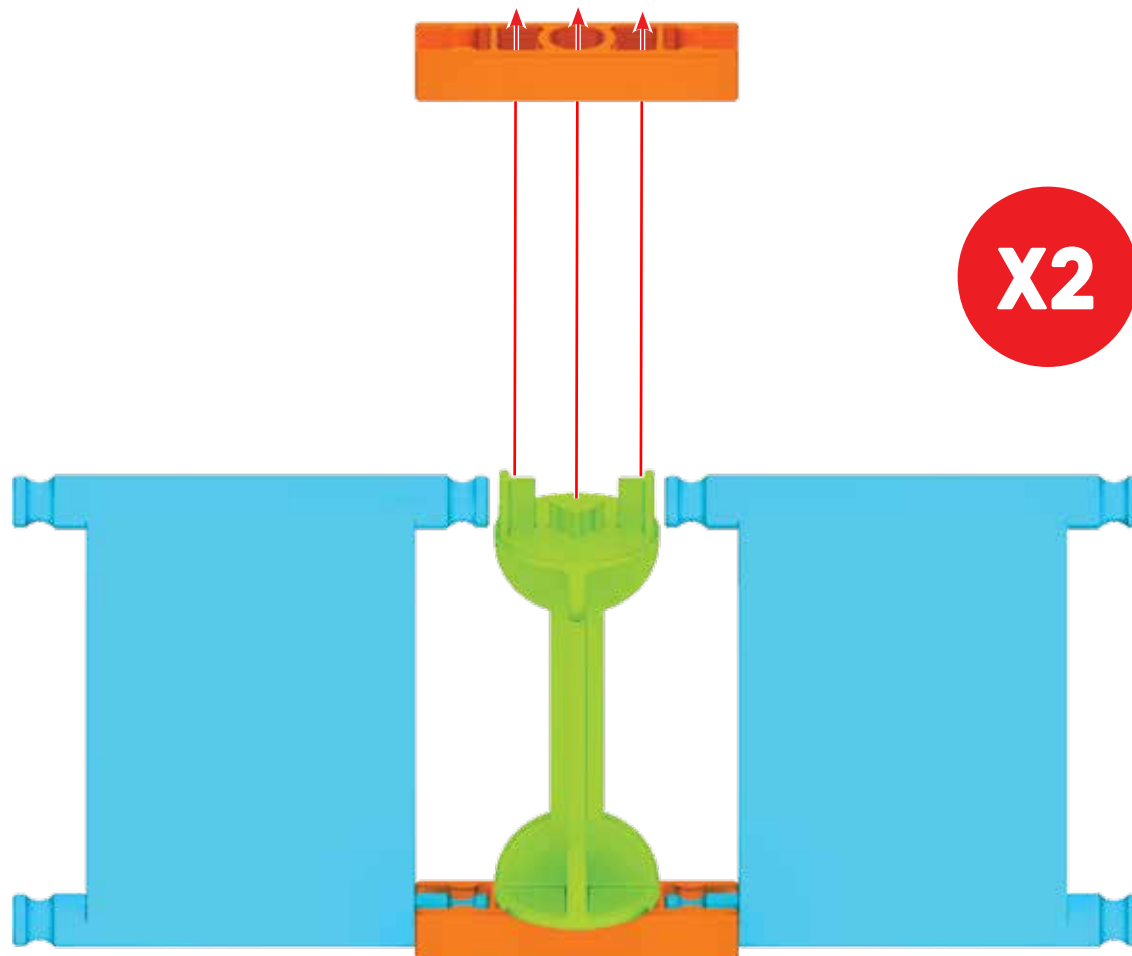

X2

3

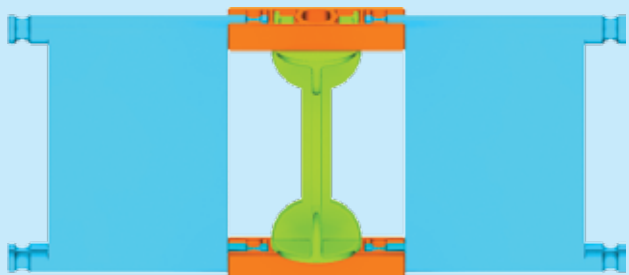

4

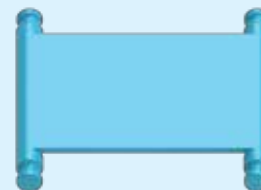

4



2



4

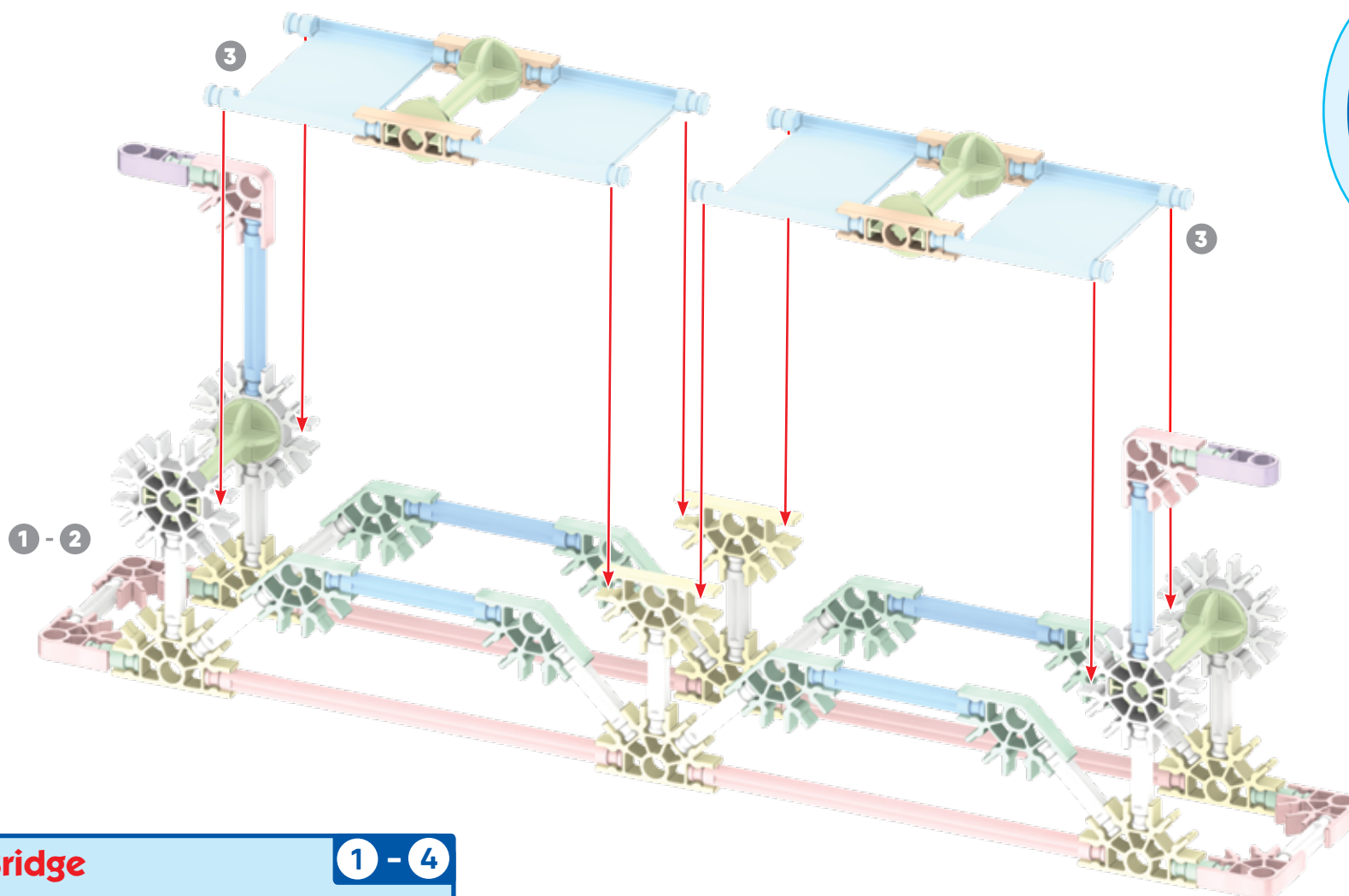

Rotate
model

Stone Bridge

1 - 4

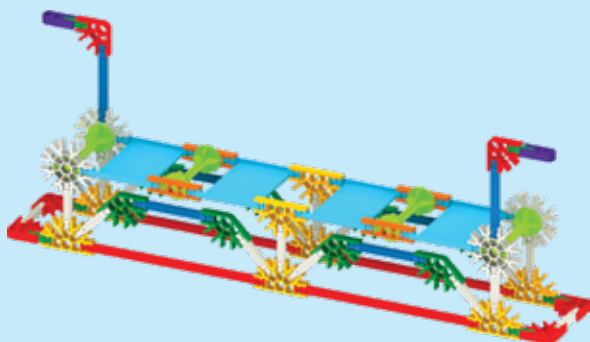

1

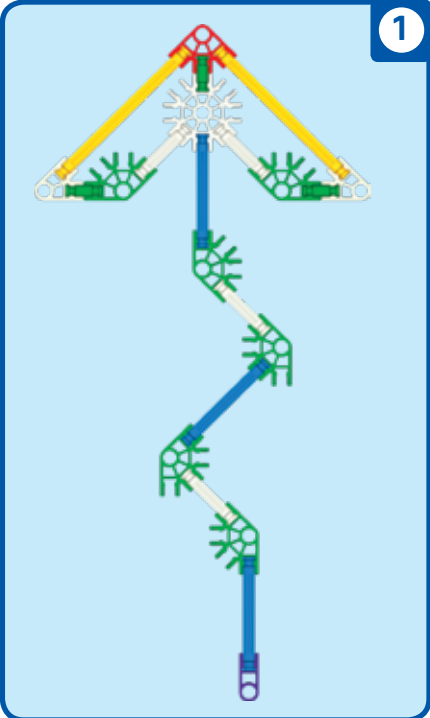
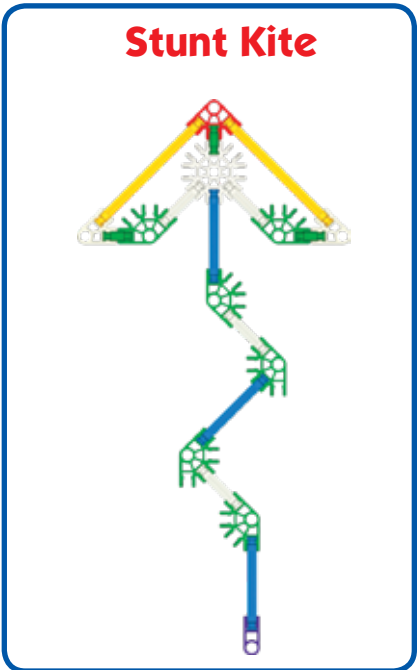
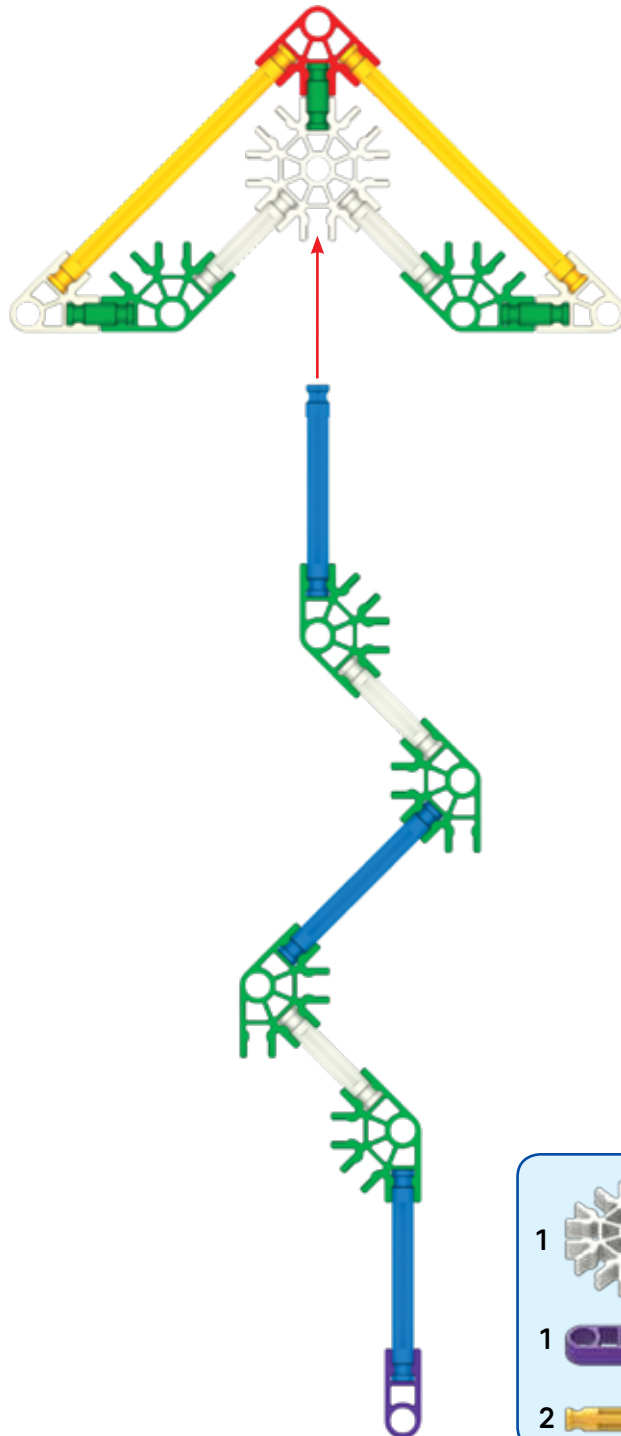

1

Train

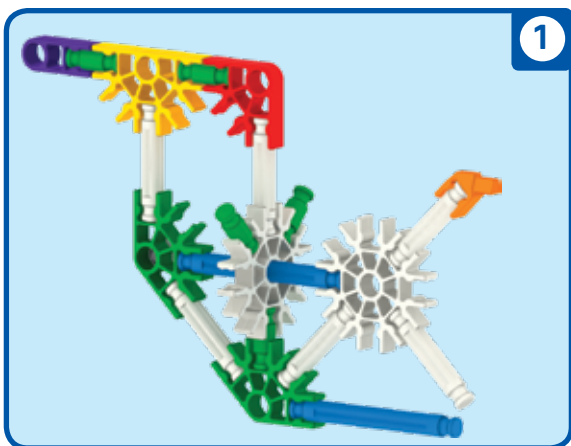
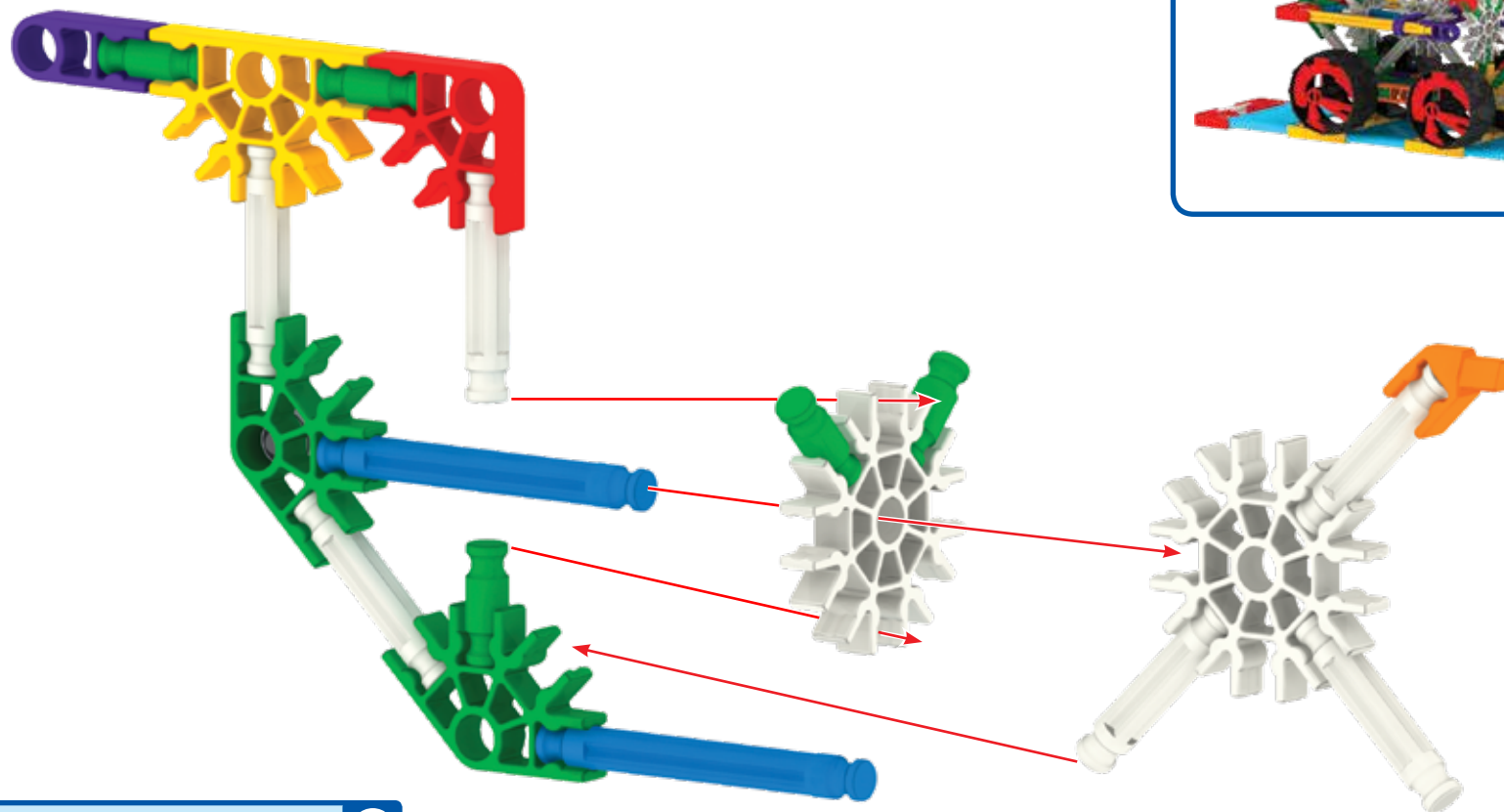

2

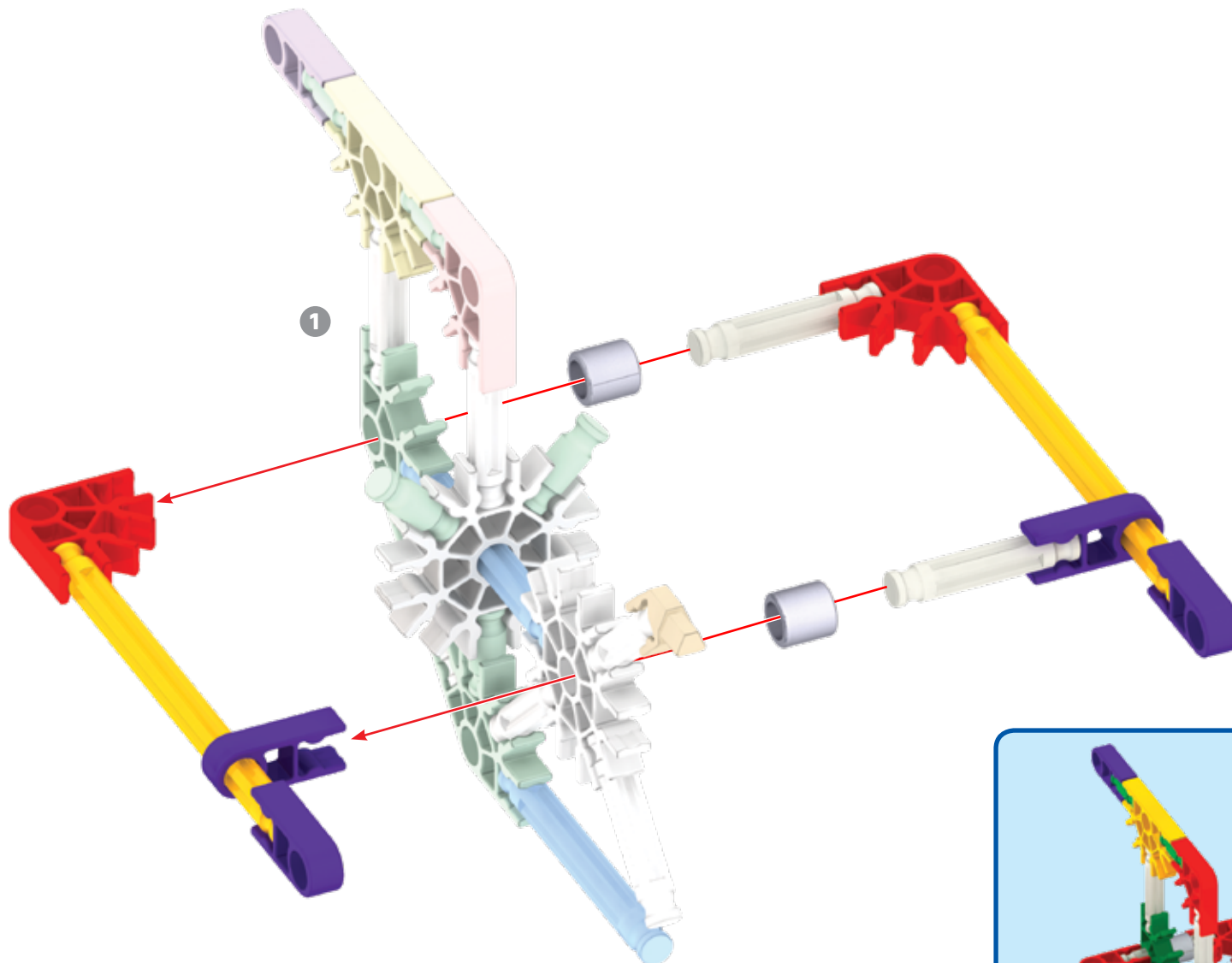

3

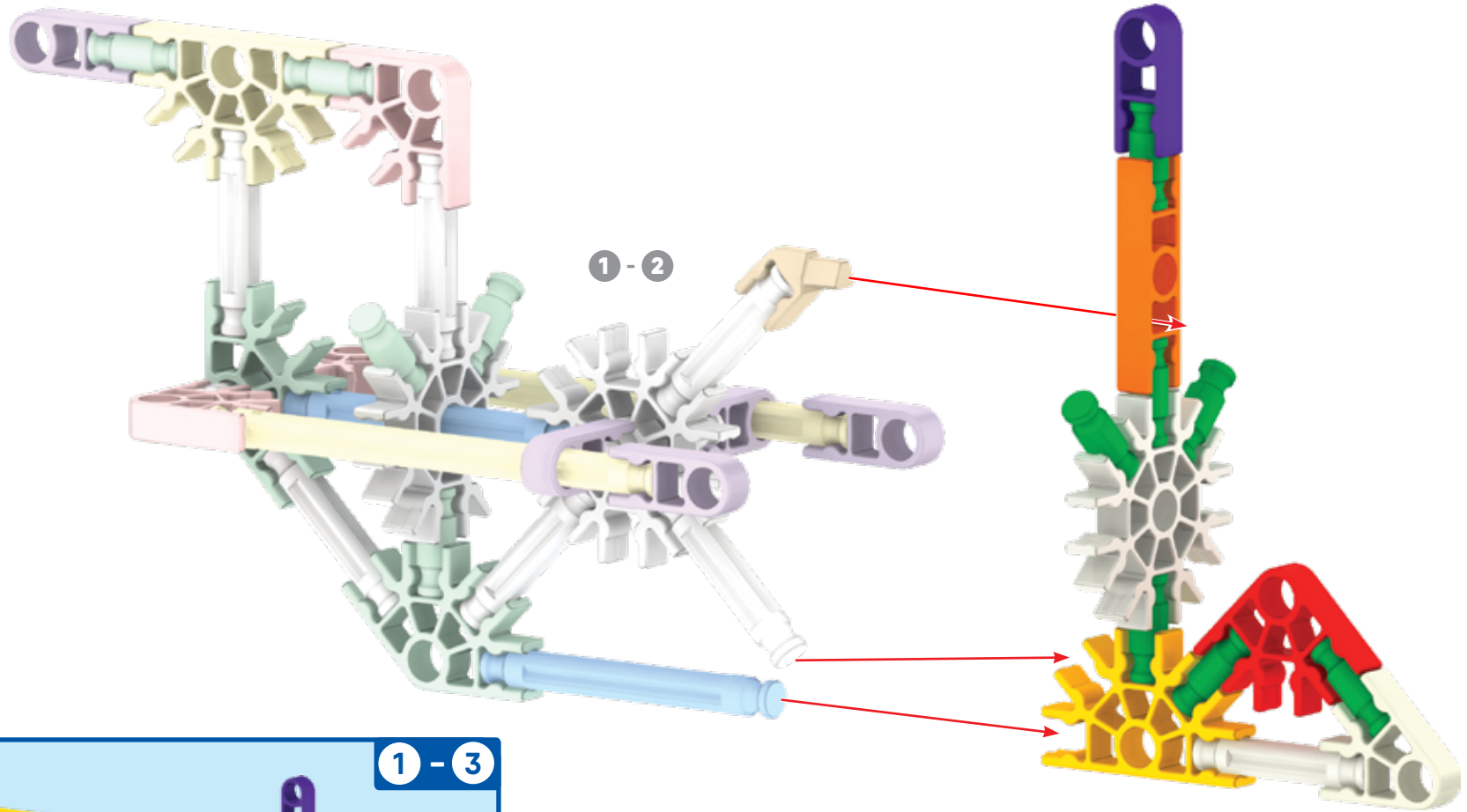

1 - 3



- | | | | | | | | |
|---|--|---|--|---|--|---|--|
| 1 | | 1 | | 1 | | 1 | |
| 1 | | 1 | | 7 | | 1 | |

4

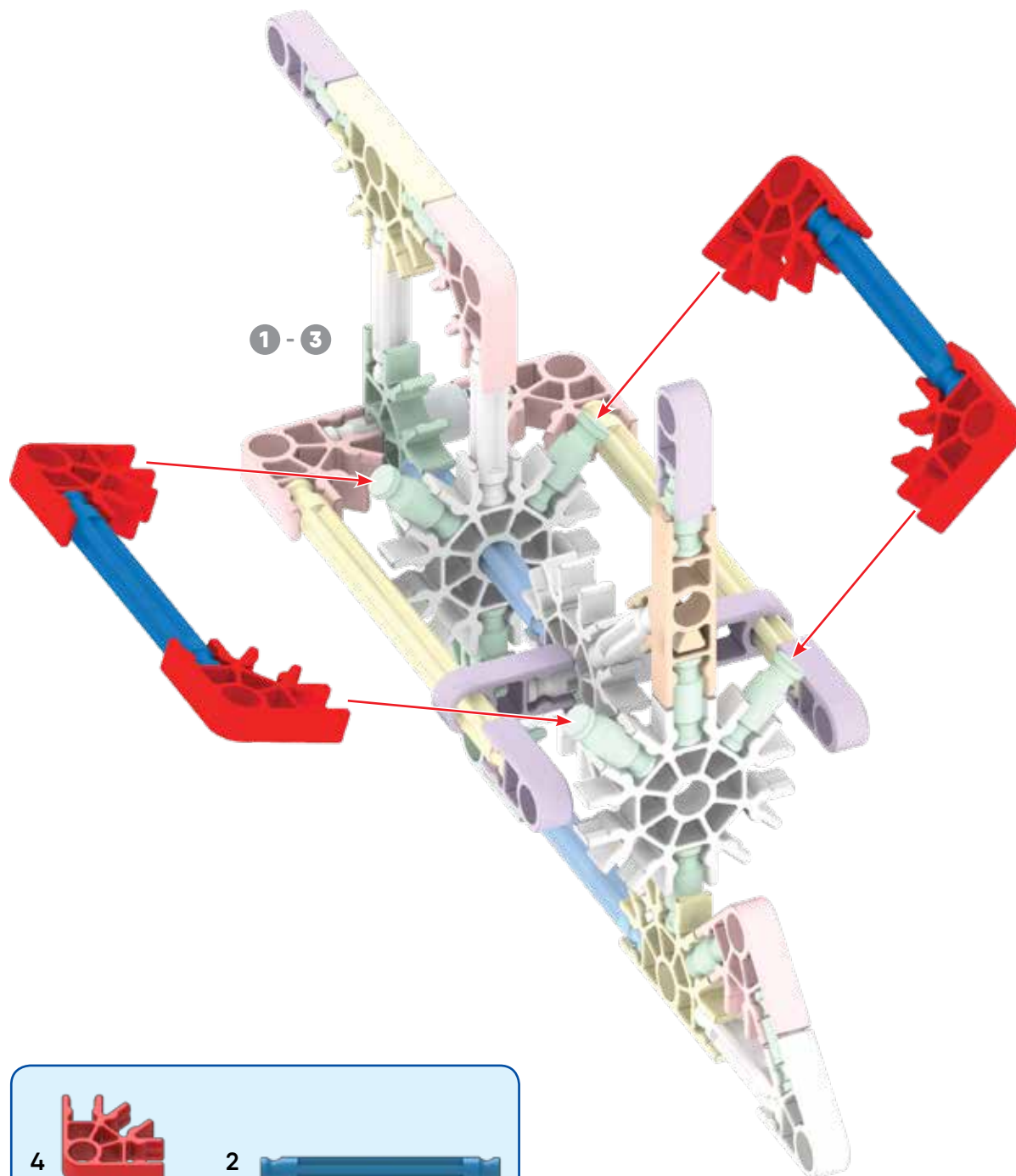

1 - 4

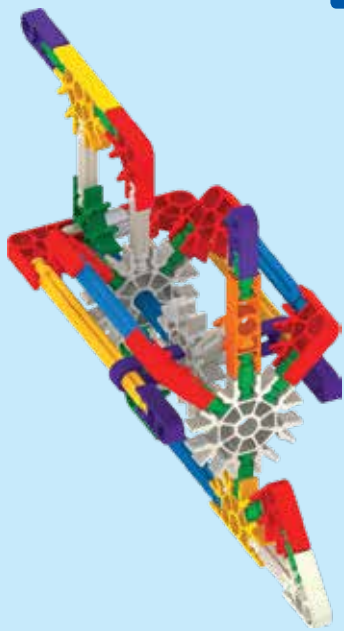

4



2



5

X2



X2

5



2



4



2



6

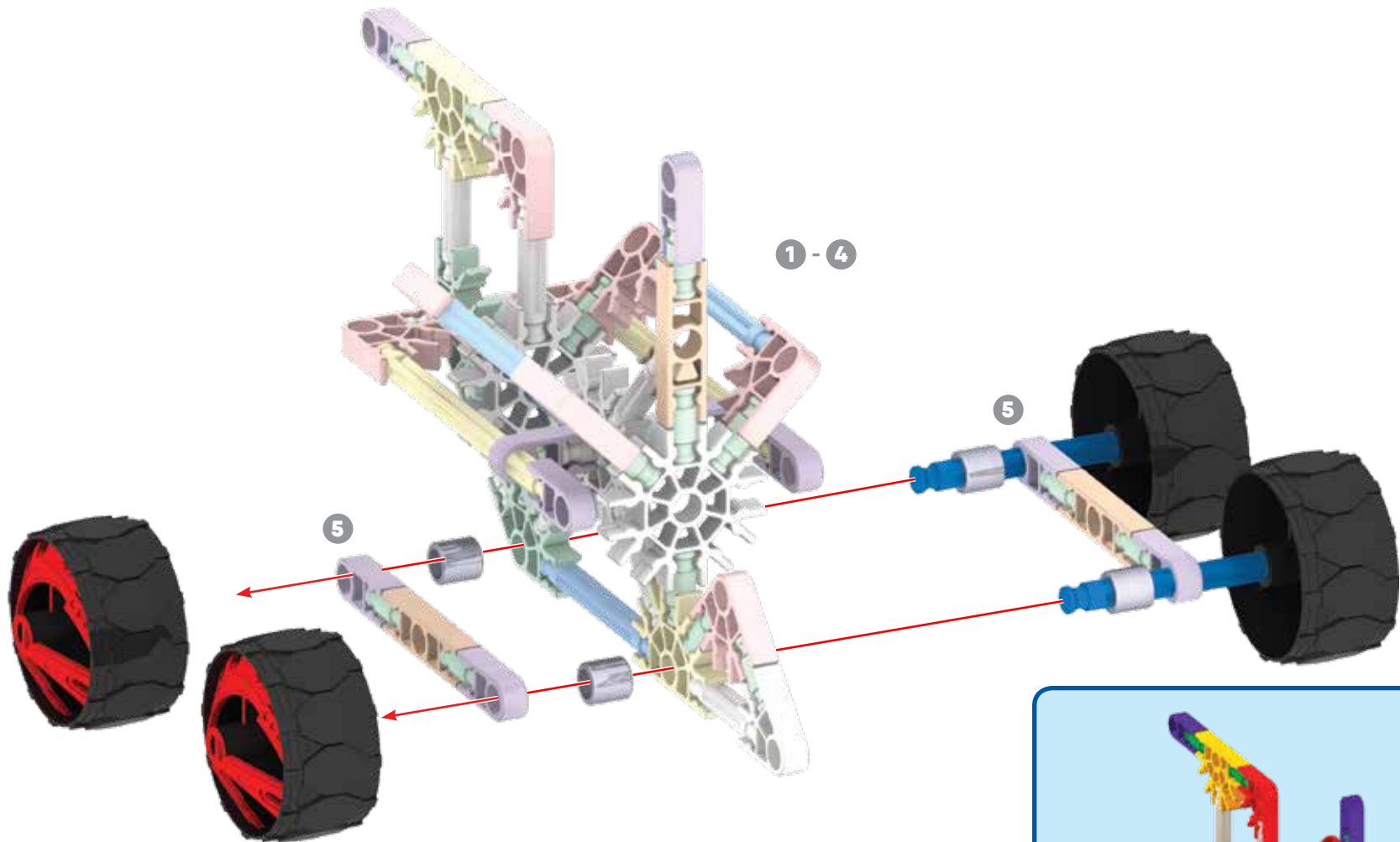

7

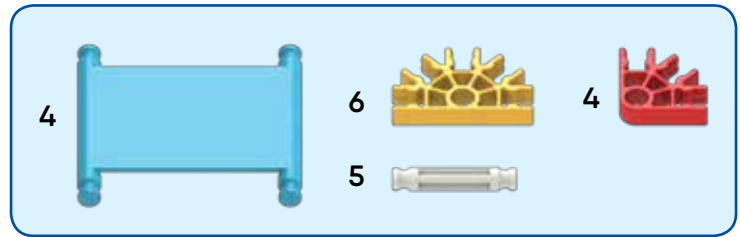
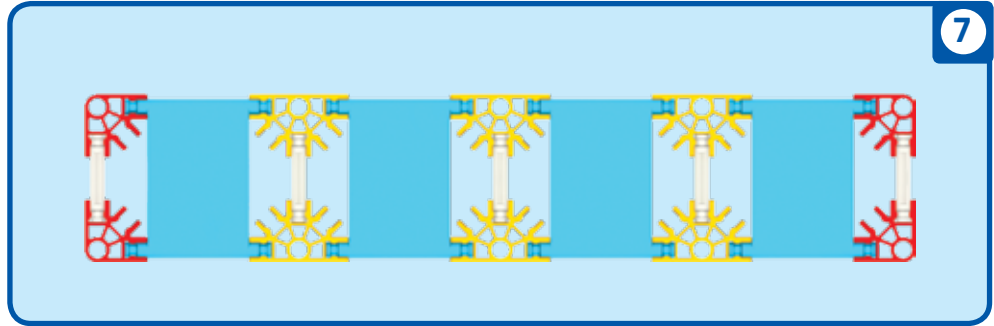
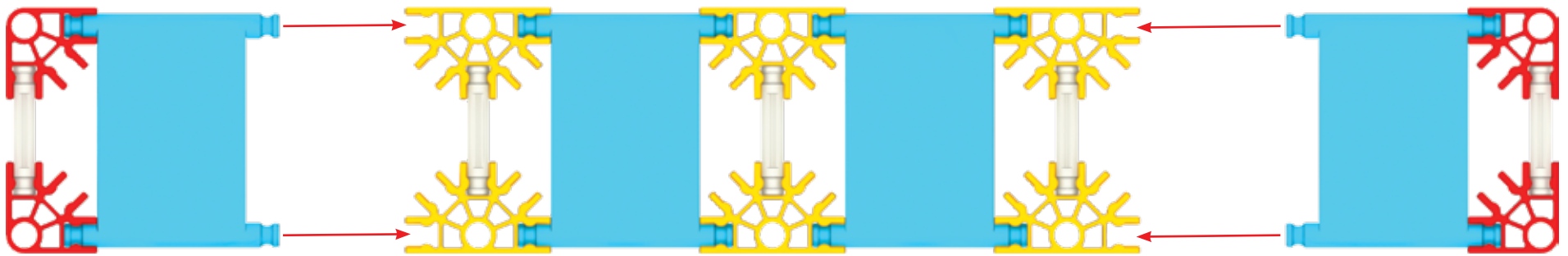

8

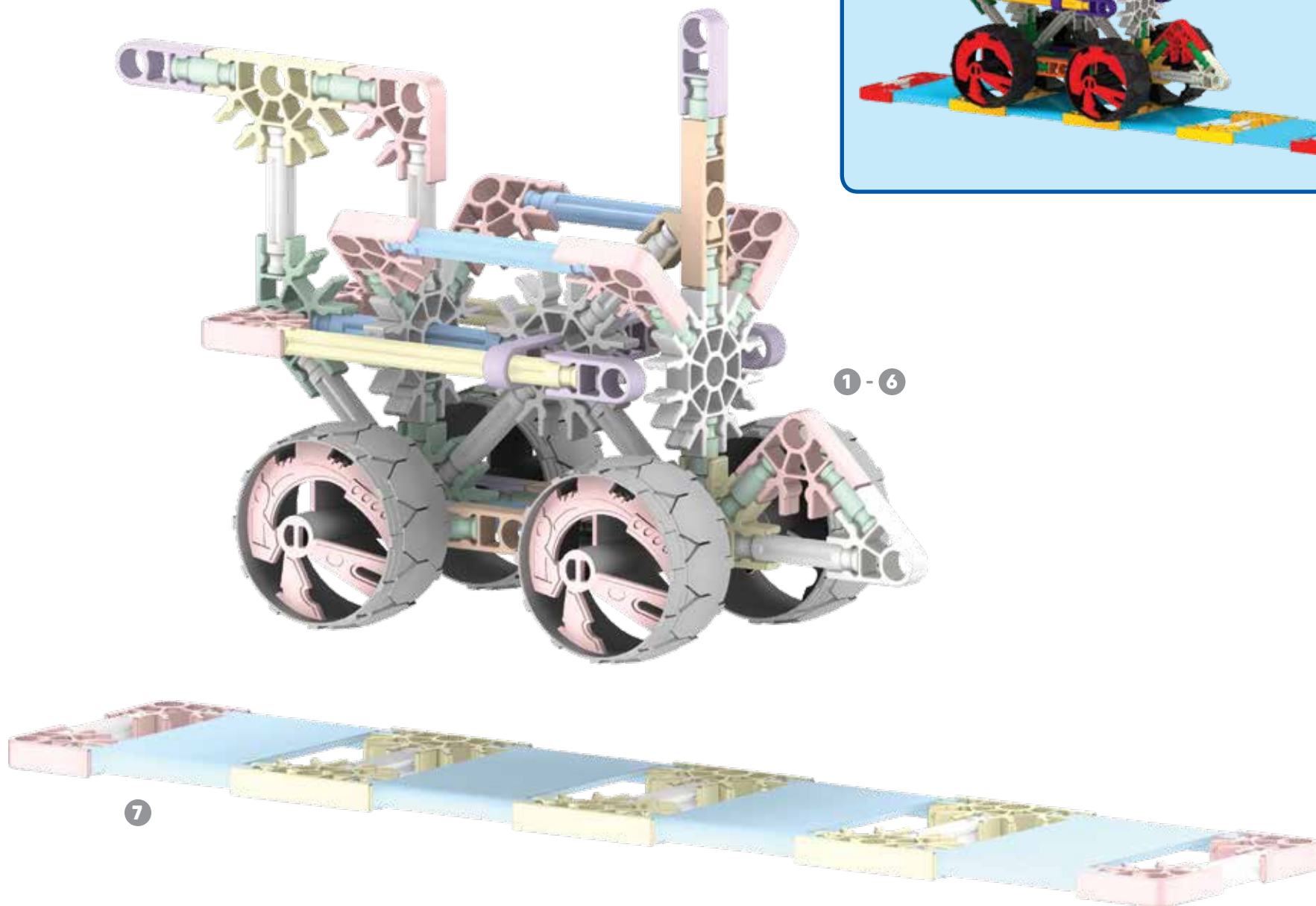

Train

1 - 8

1

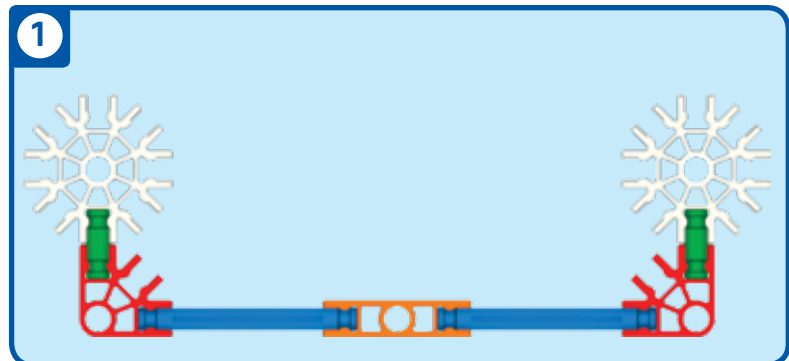

2

X2

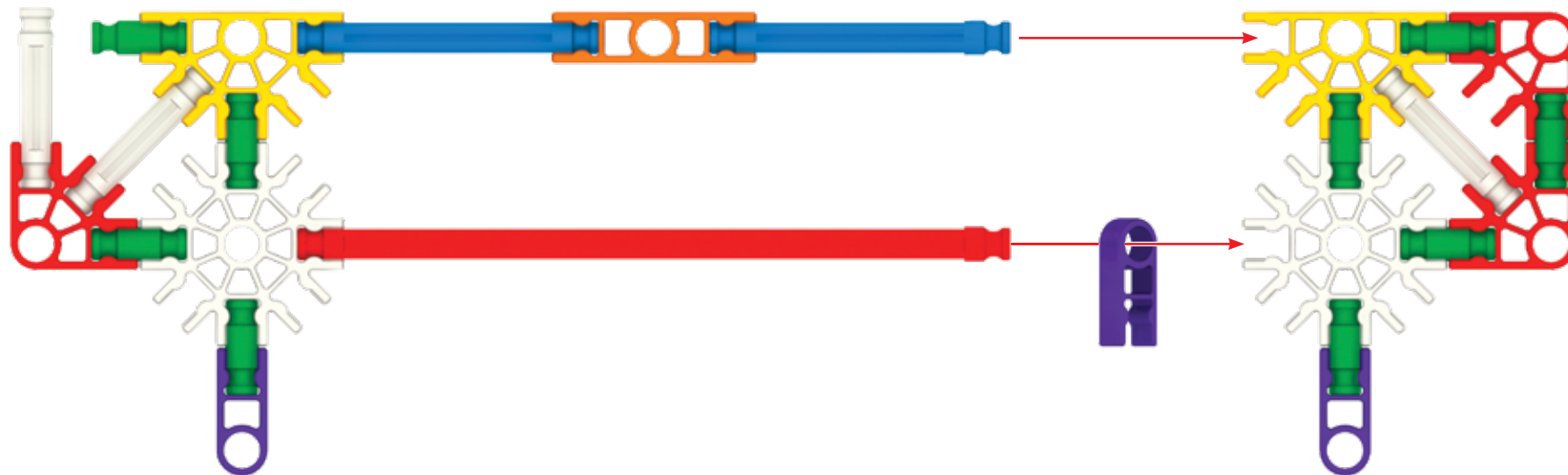

2

X2

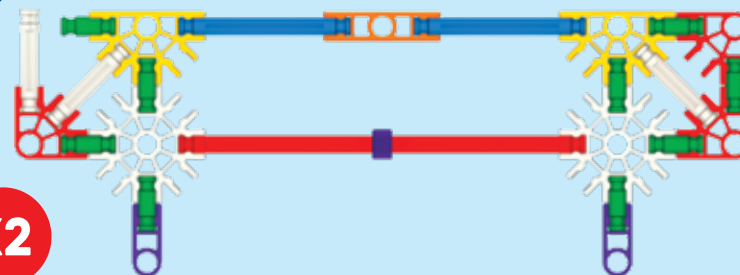

3

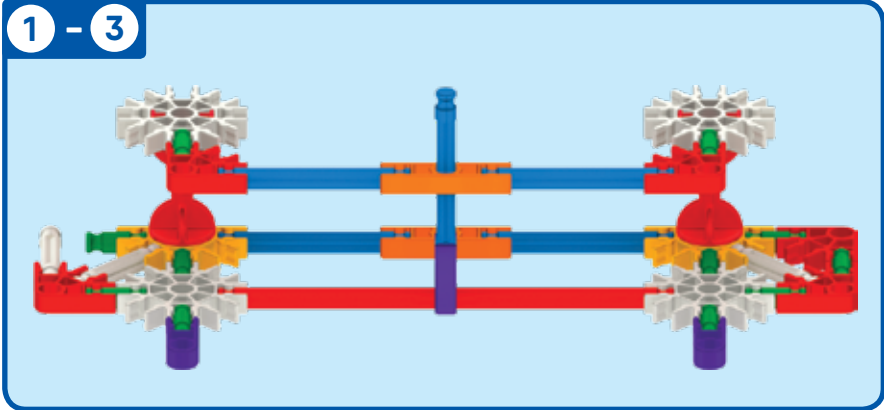
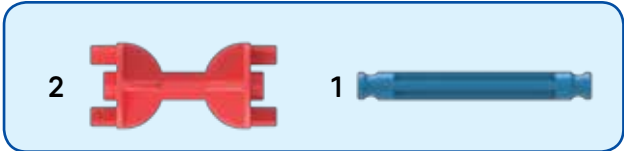
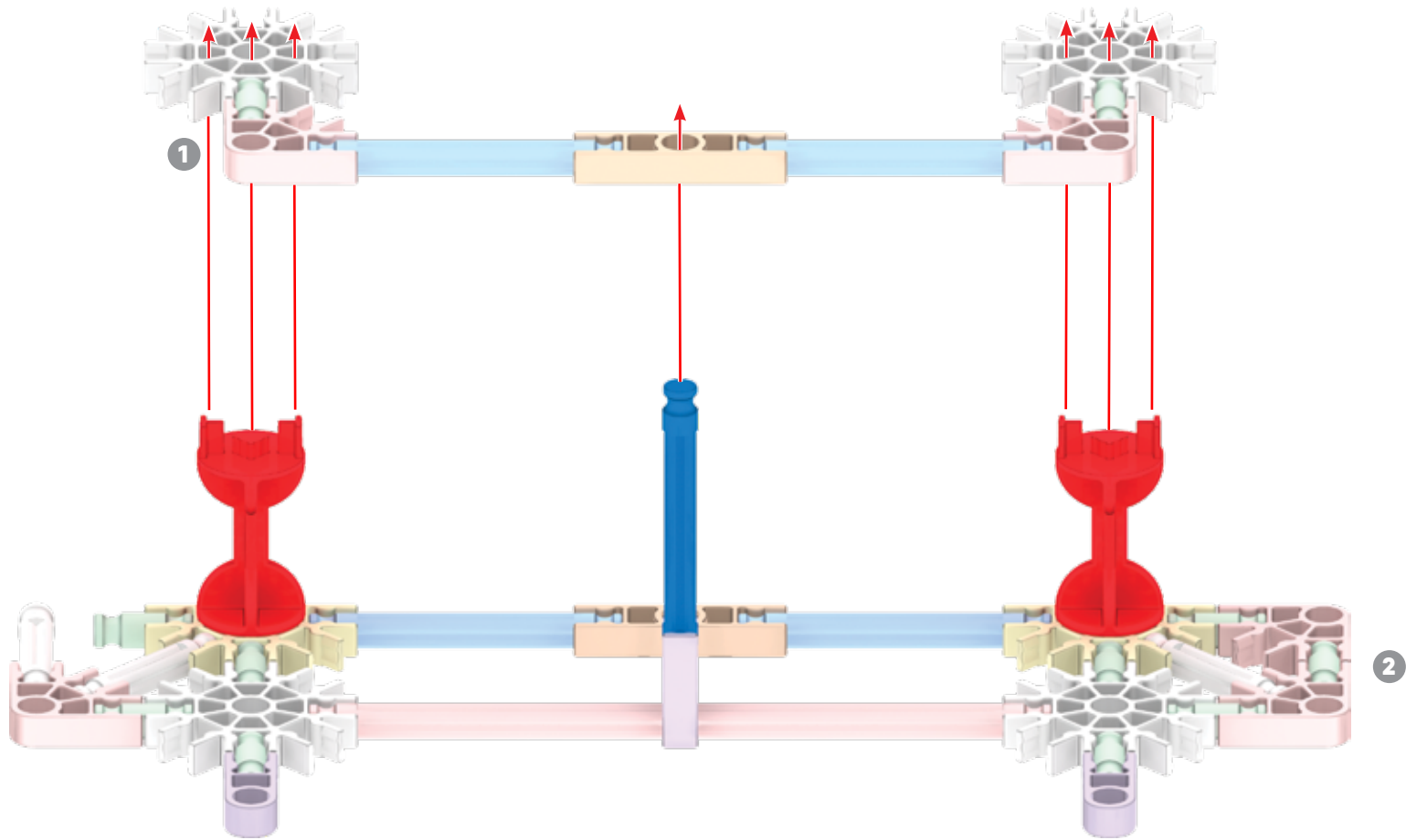

4

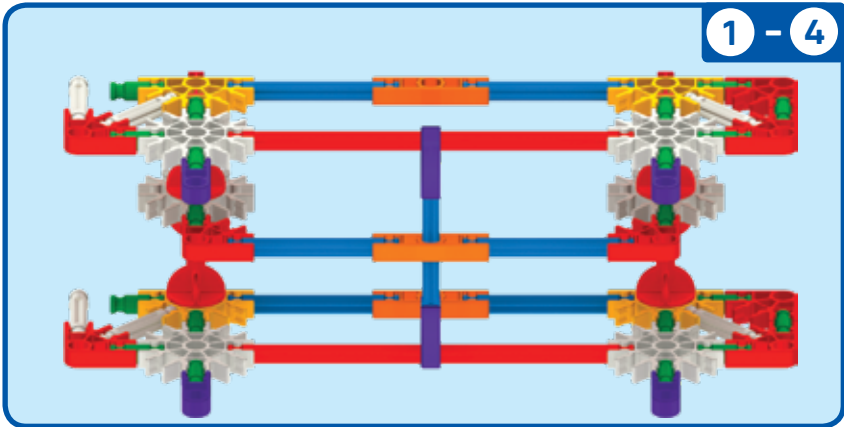
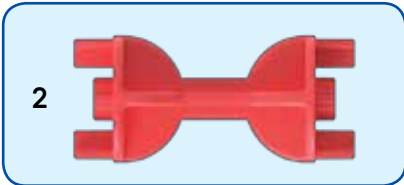
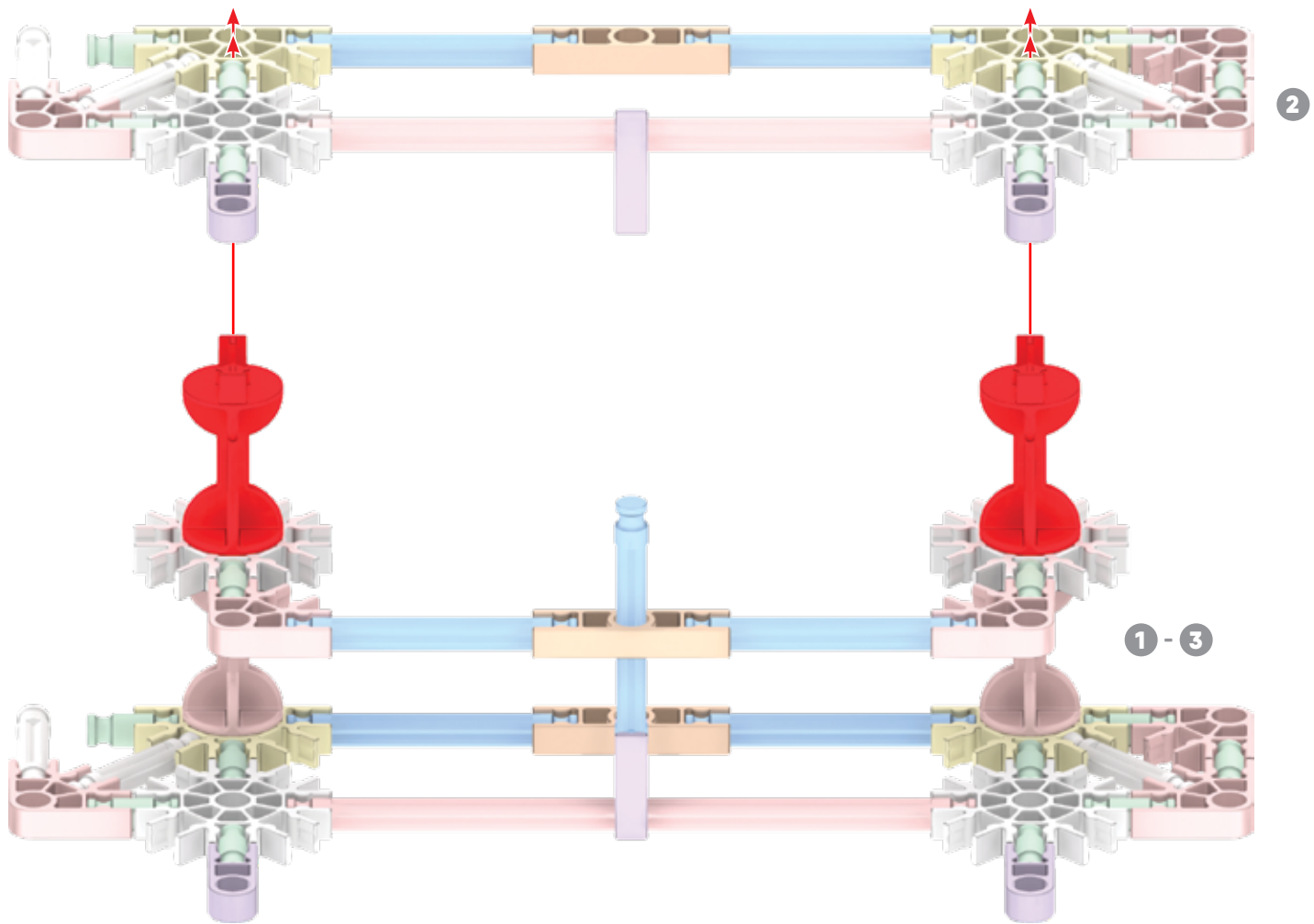

5

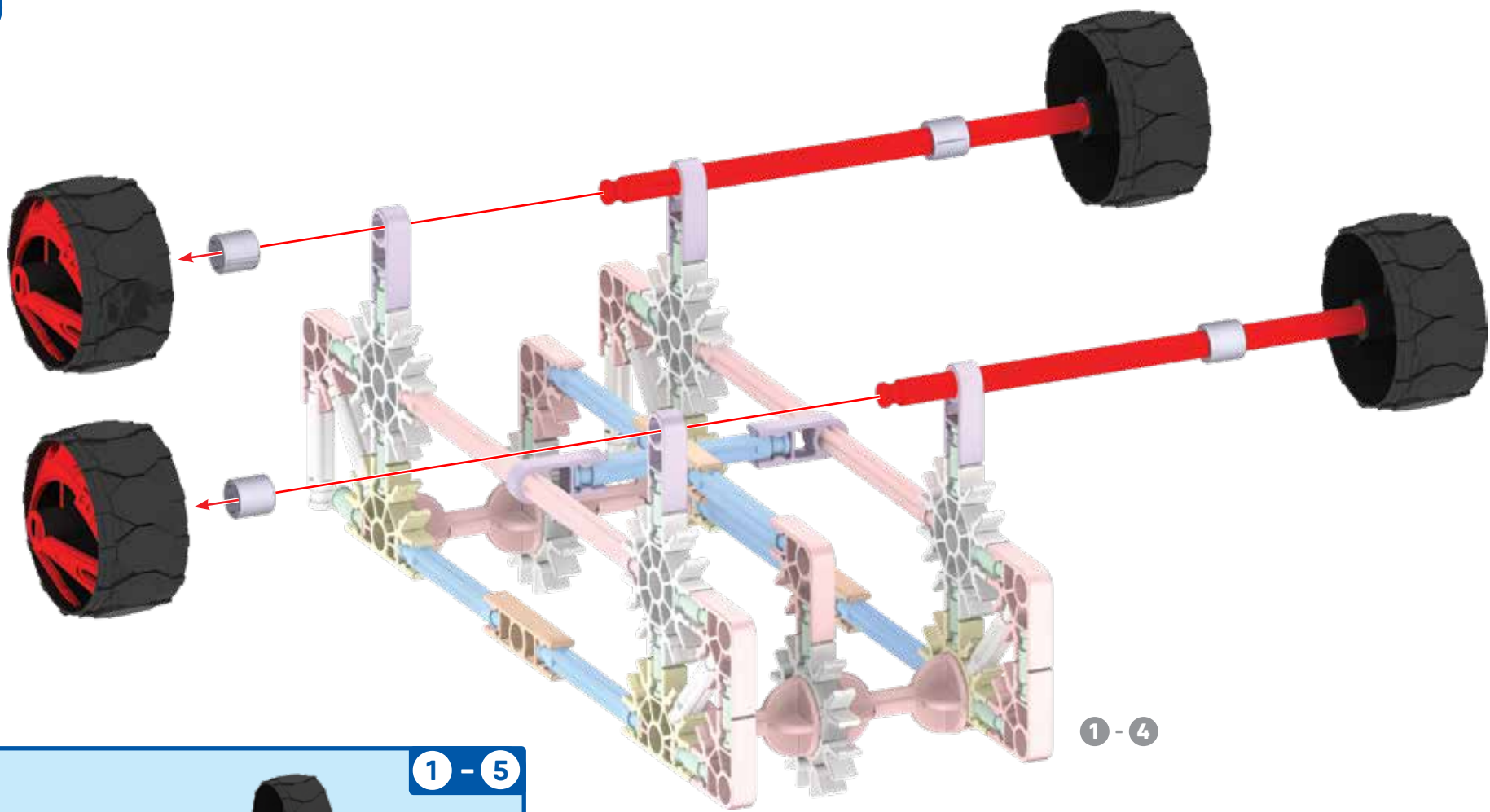

1 - 4

1 - 5

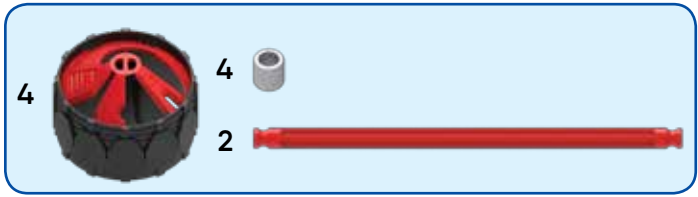
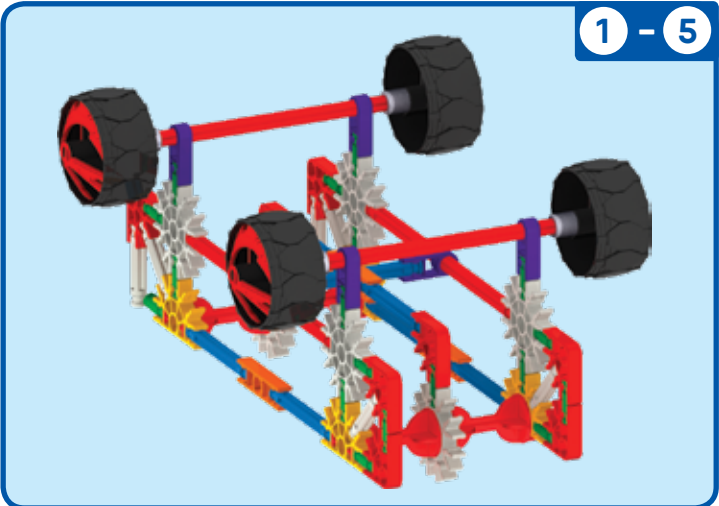

6

Rotate model



Wagon



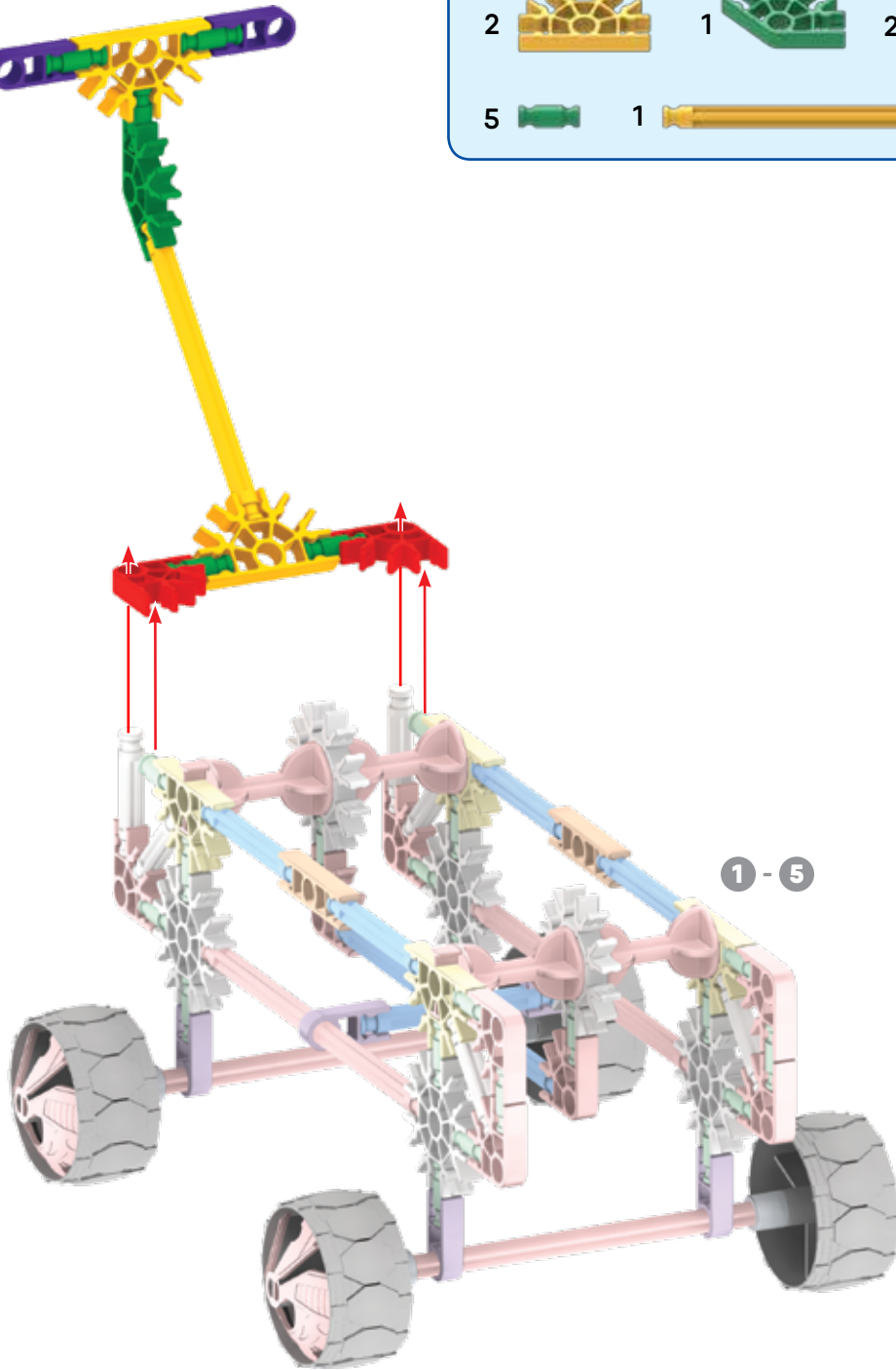
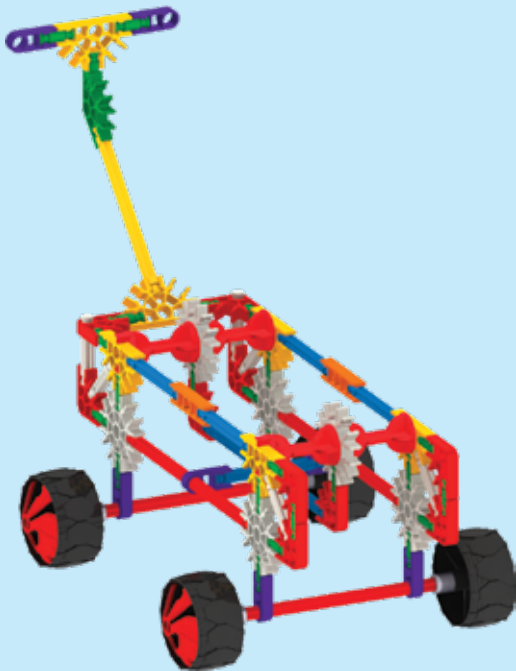



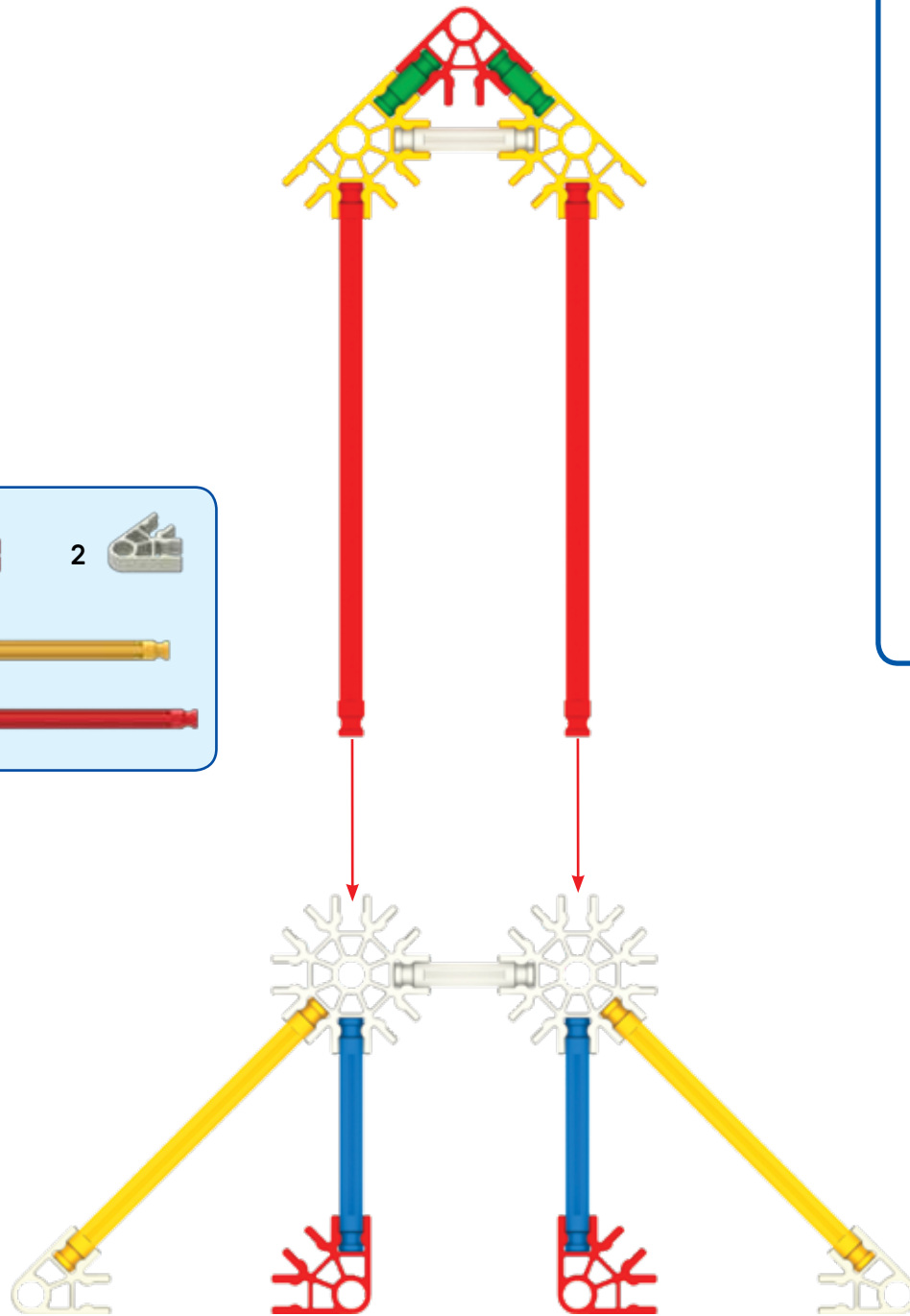
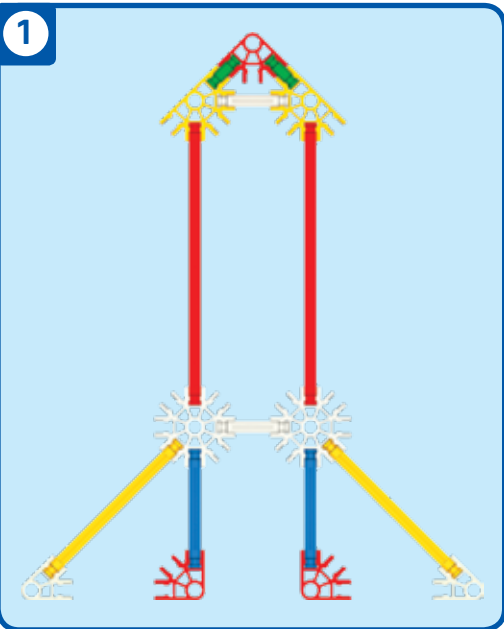
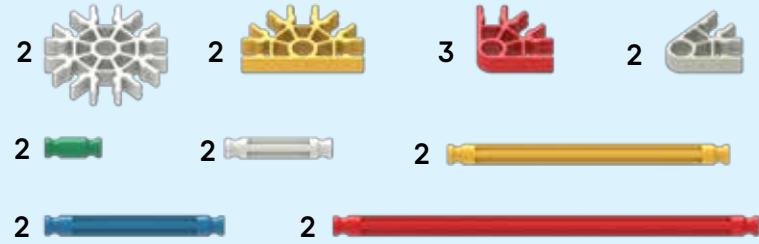

1 - 6

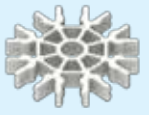

1



2

- 2 
- 4 
- 3 
- 2 
- 2 
- 2 
- 7 
- 6 

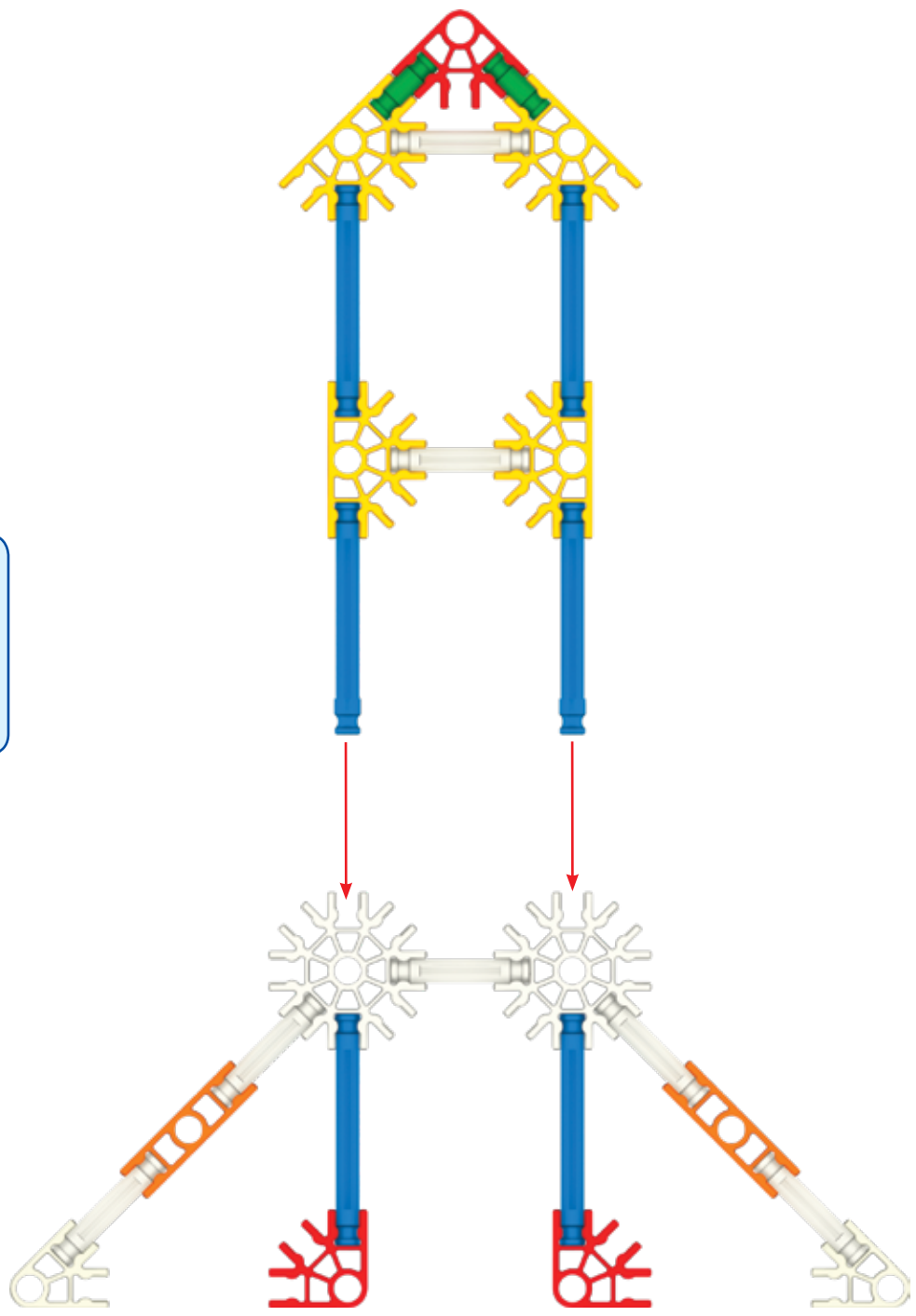
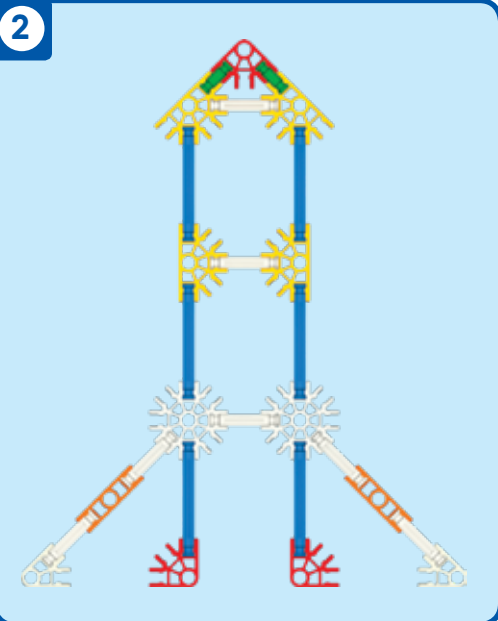

3

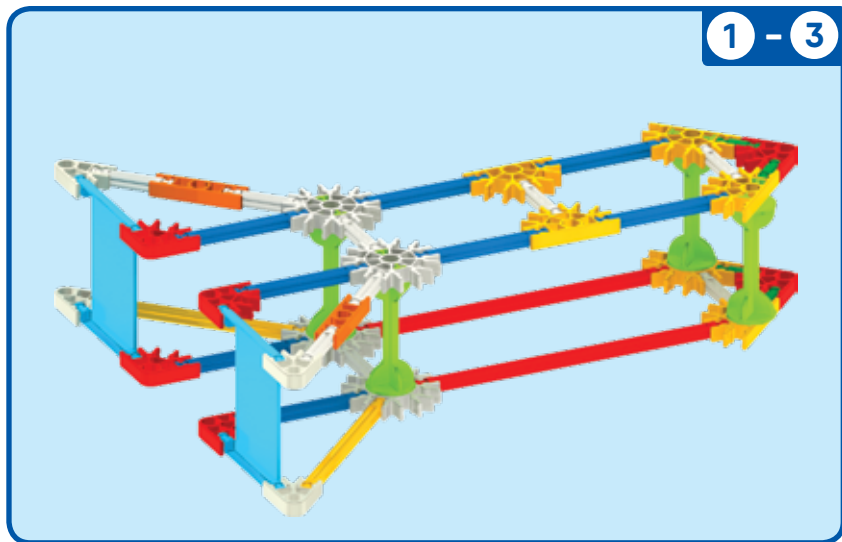
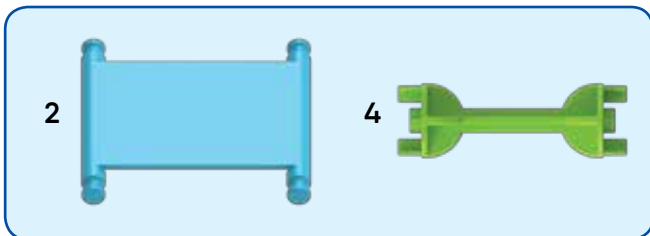
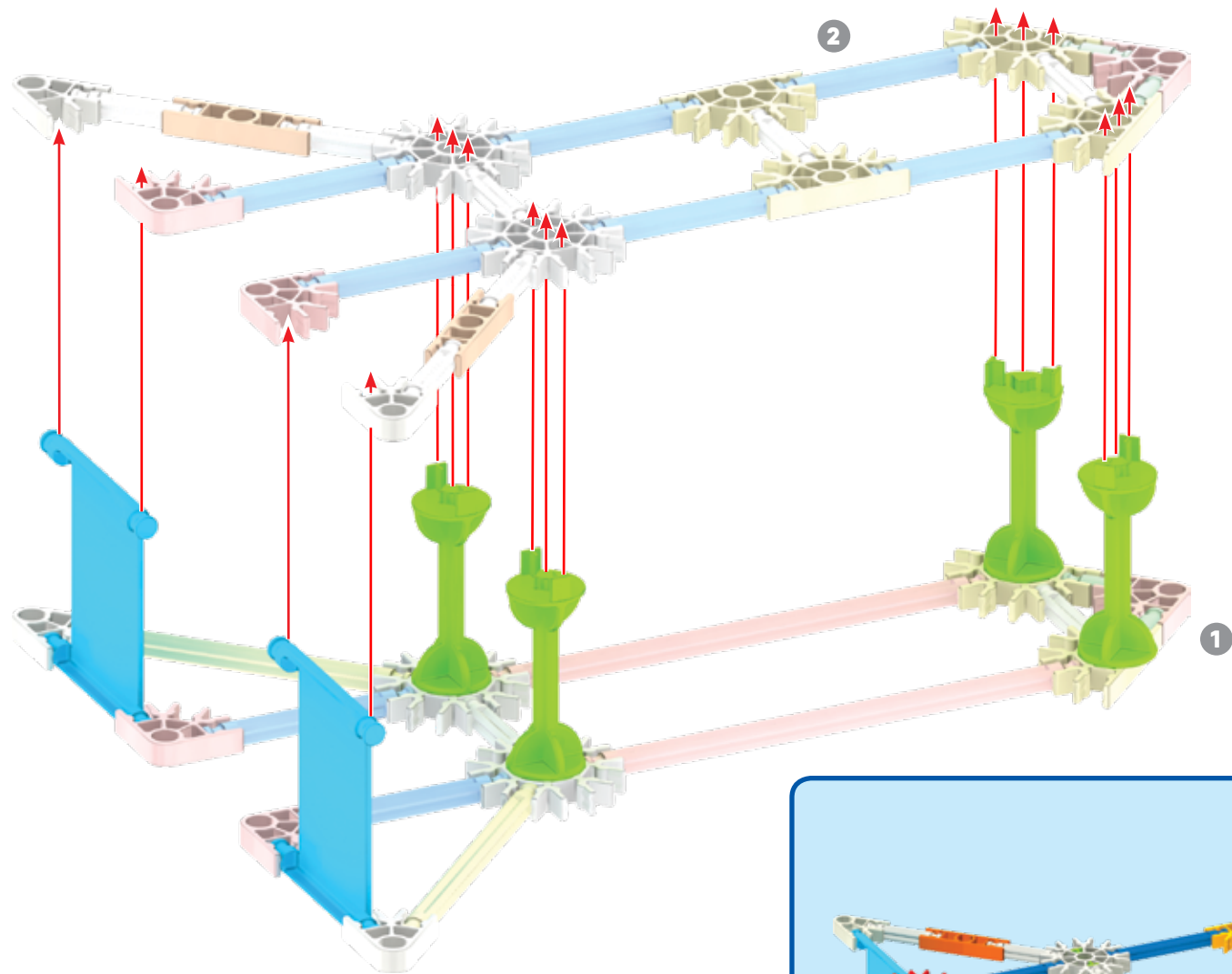

4

X2

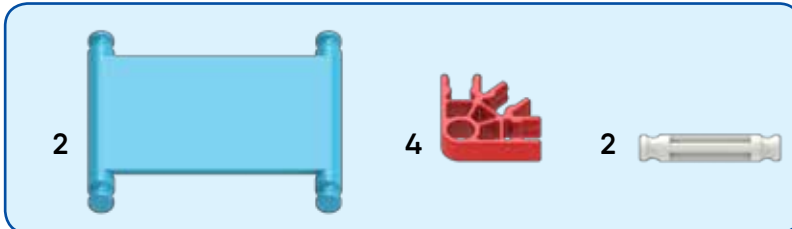
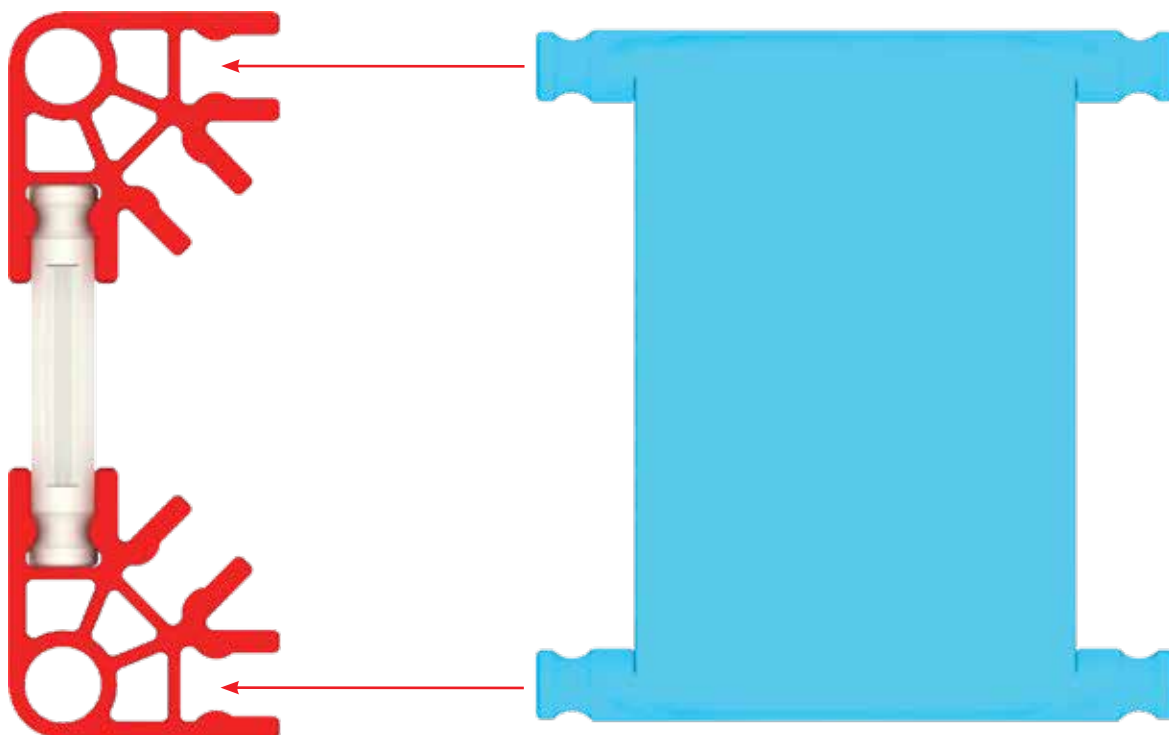

X2

4

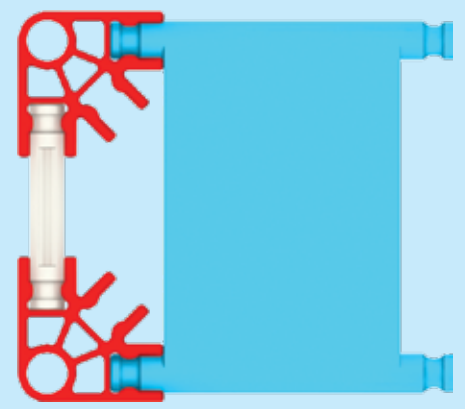

5

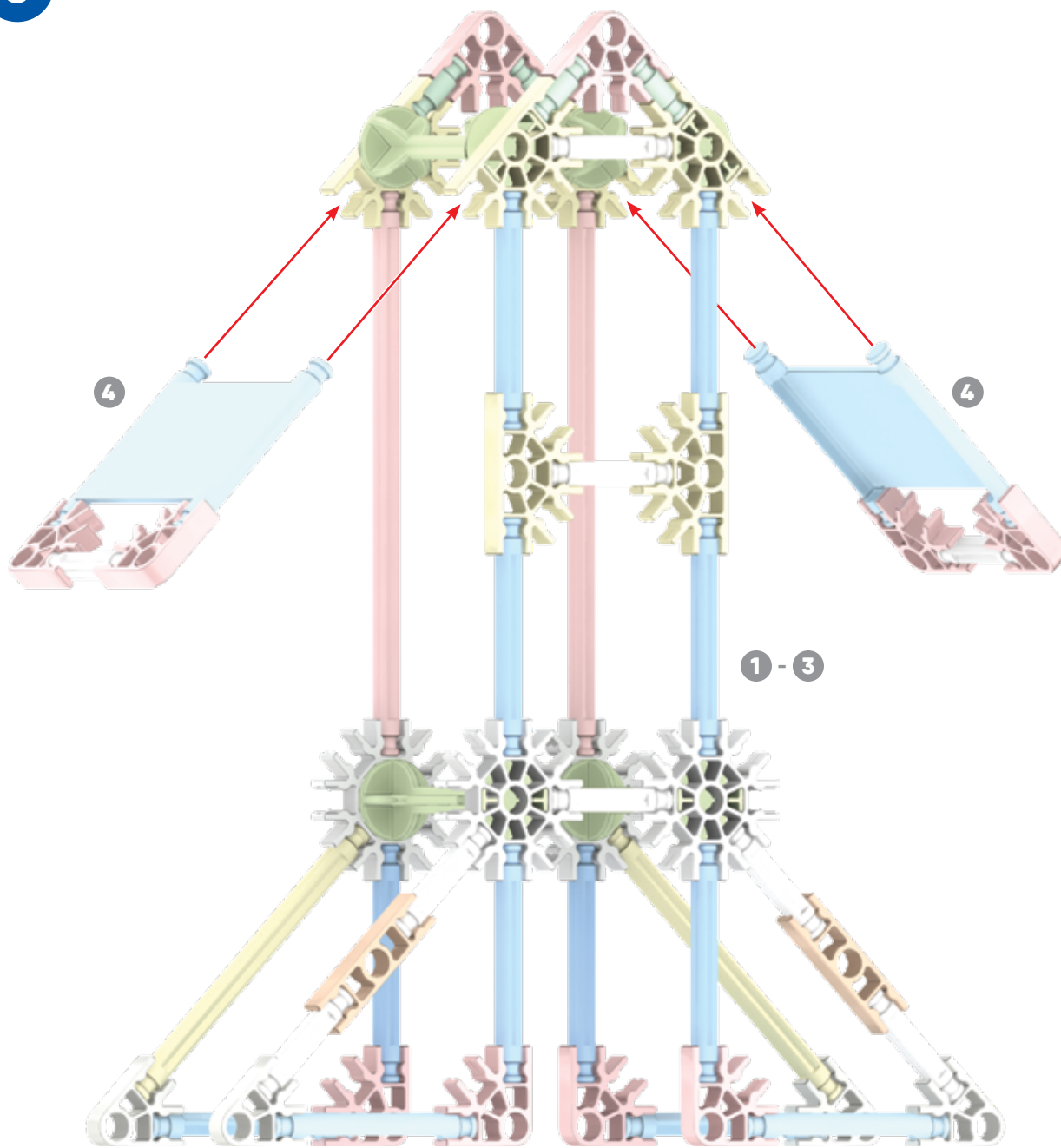

1 - 5

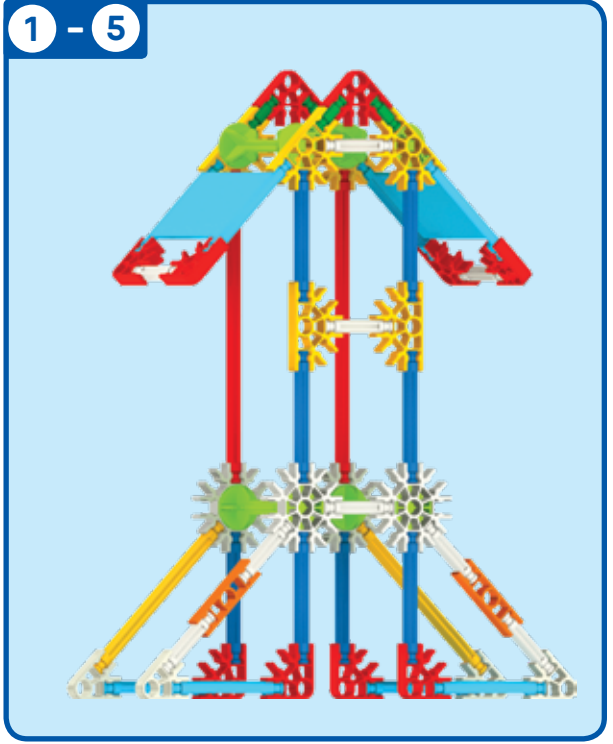

6

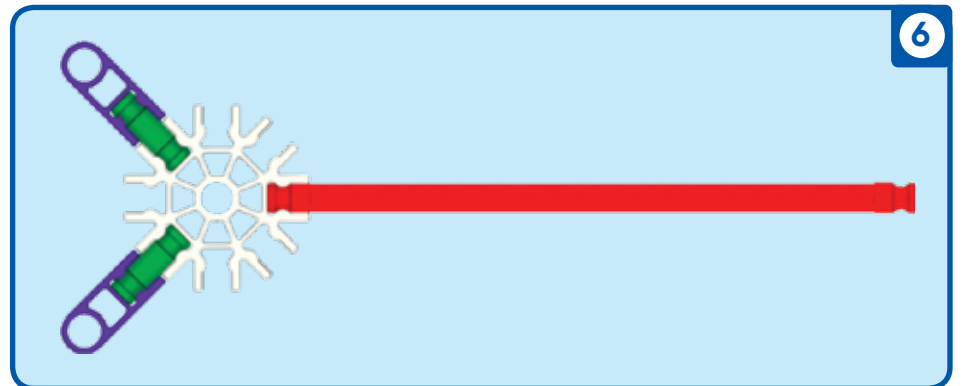
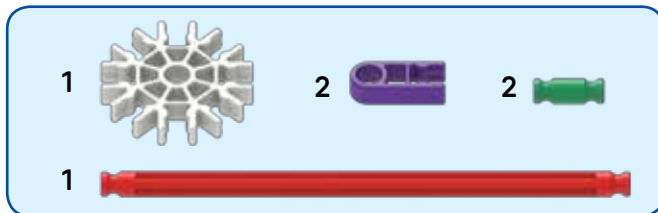
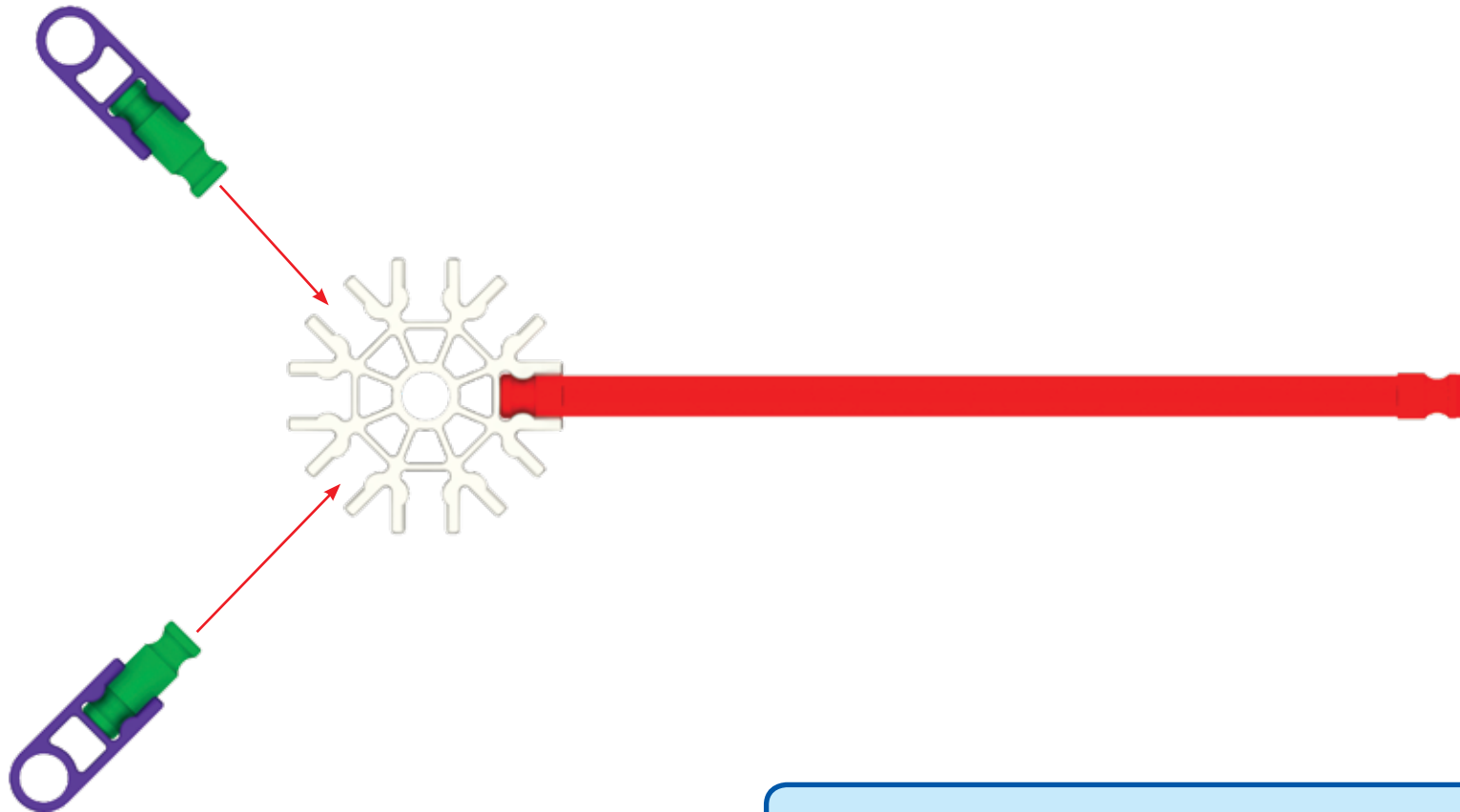

7

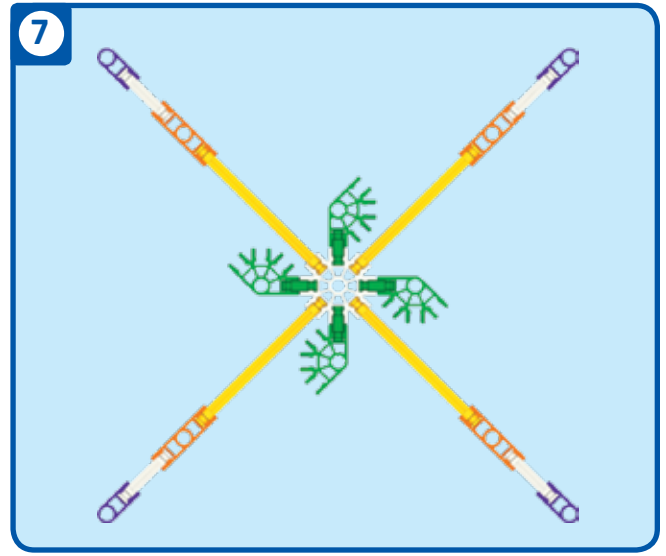
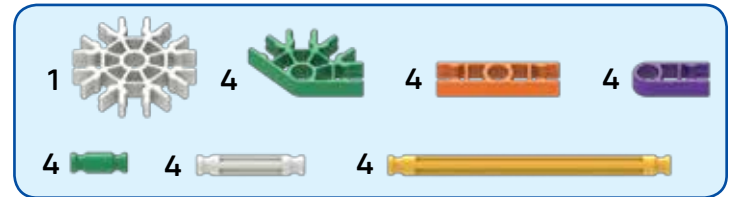
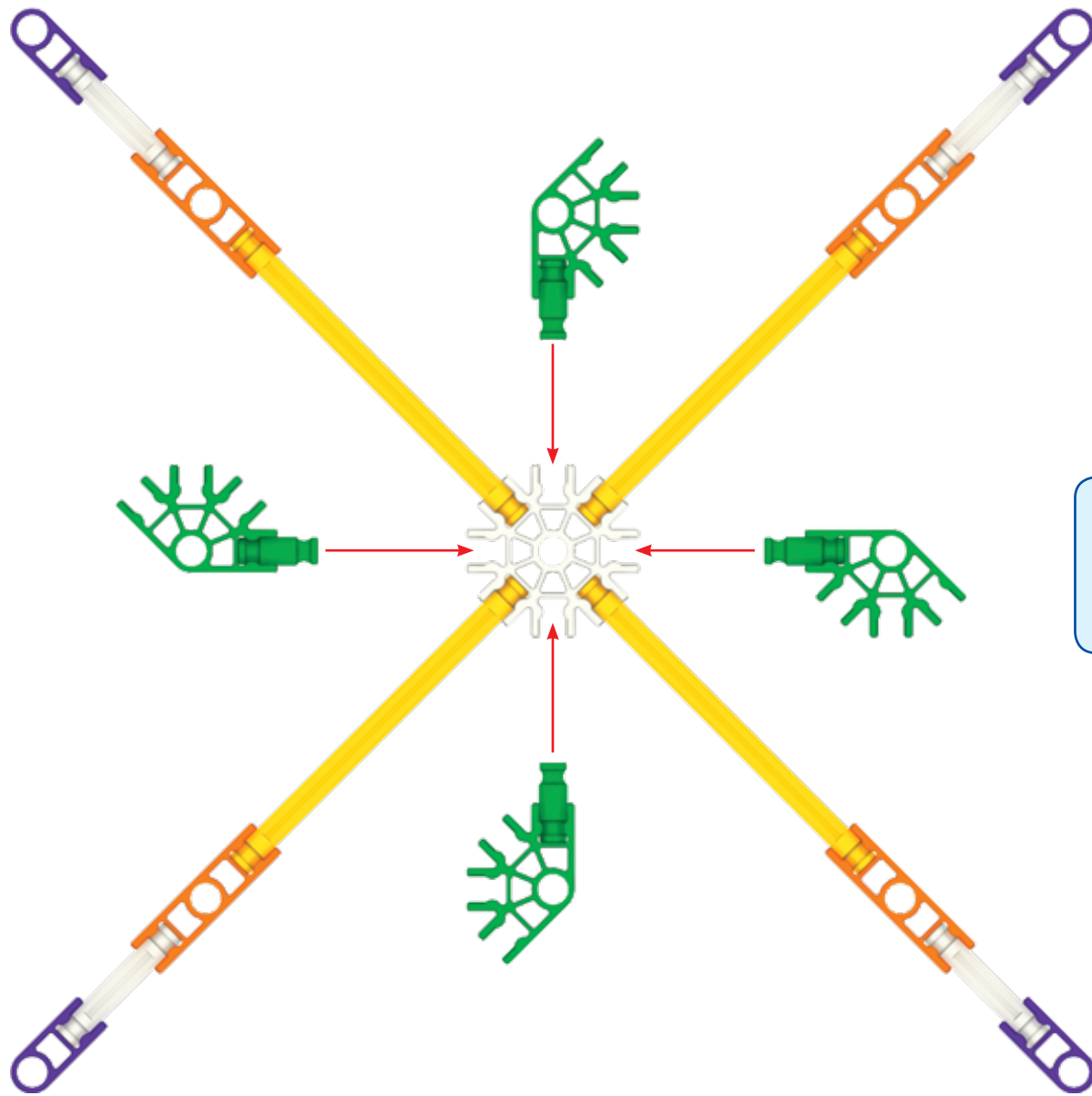

8

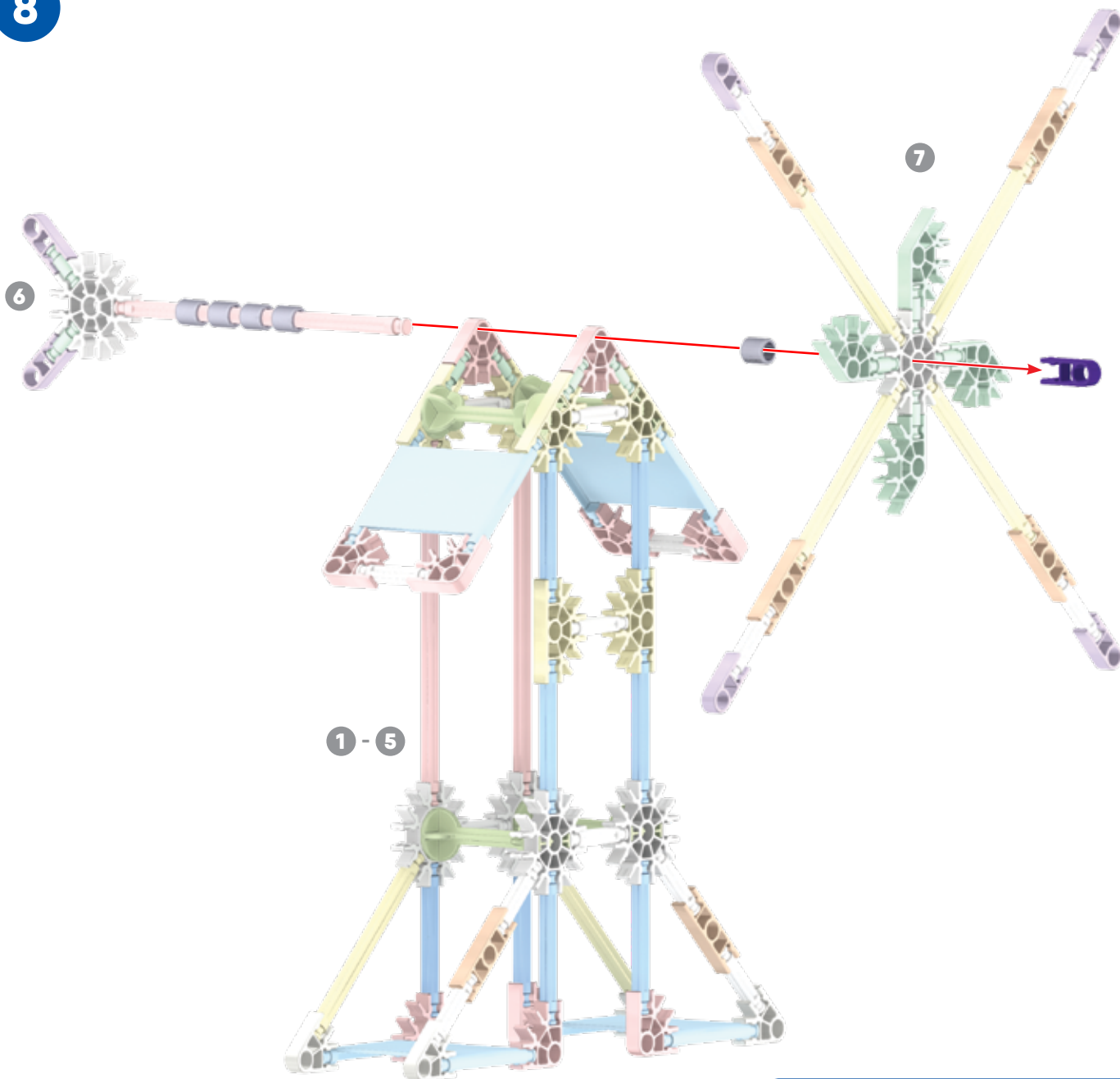

Windmill



1 - 8

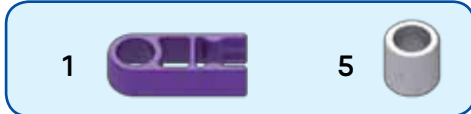

2

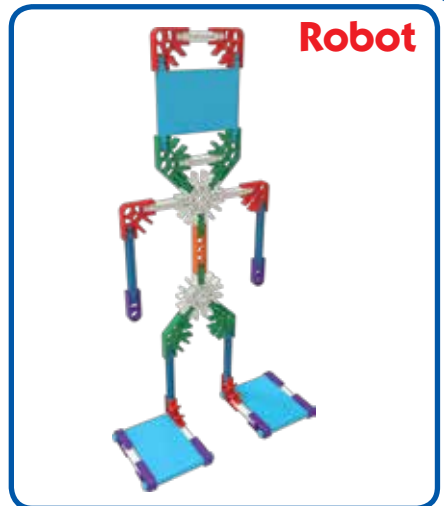
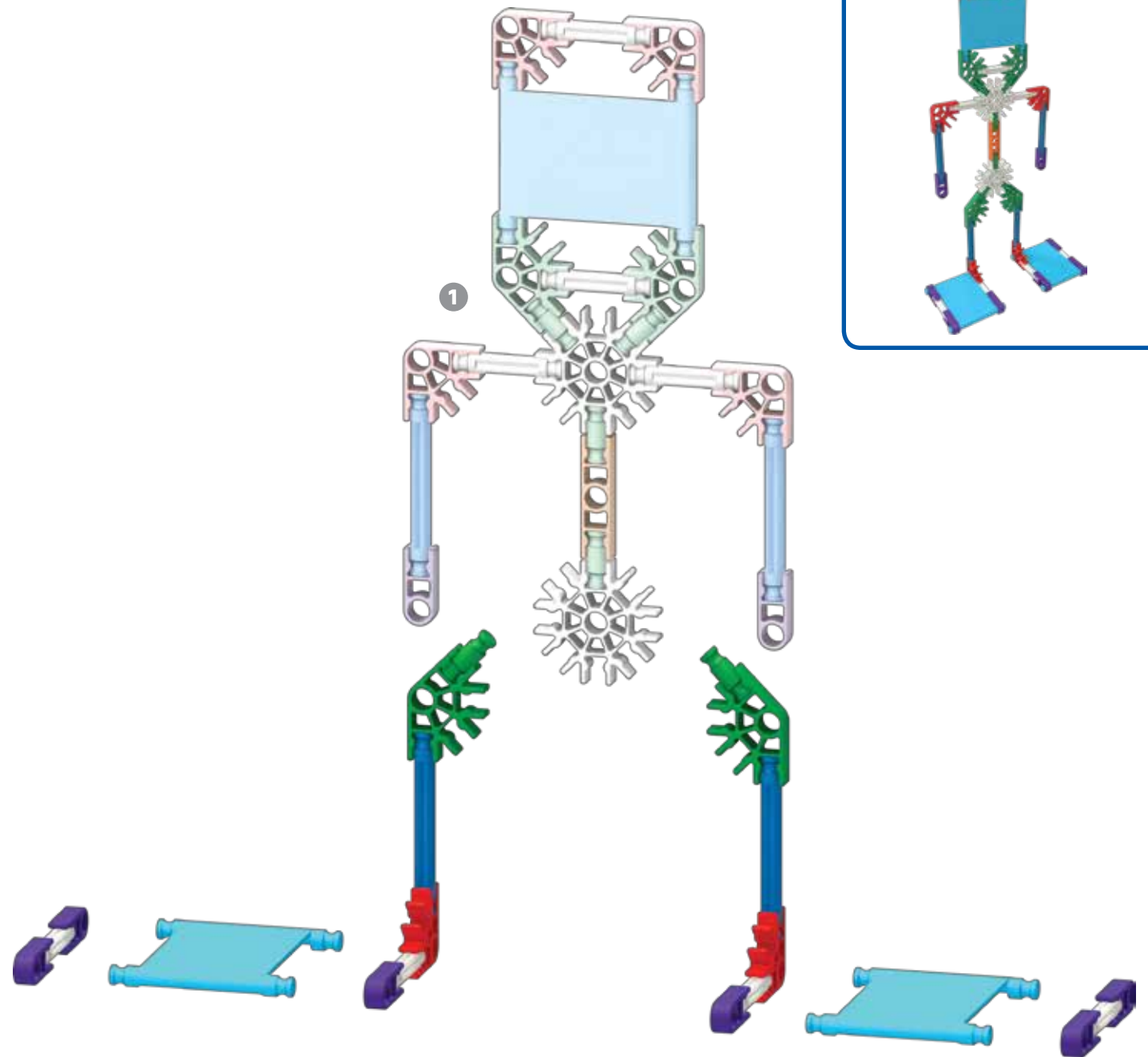
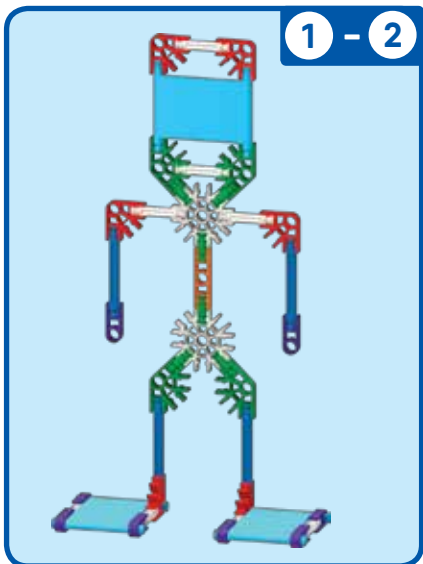
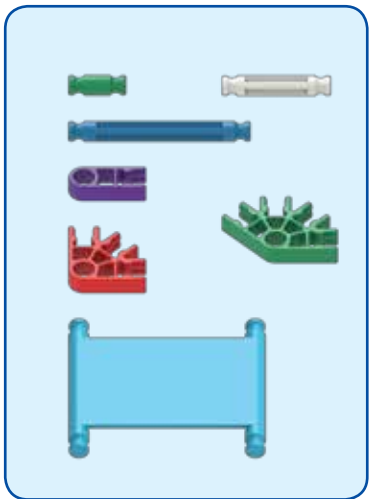

1

Helicopter

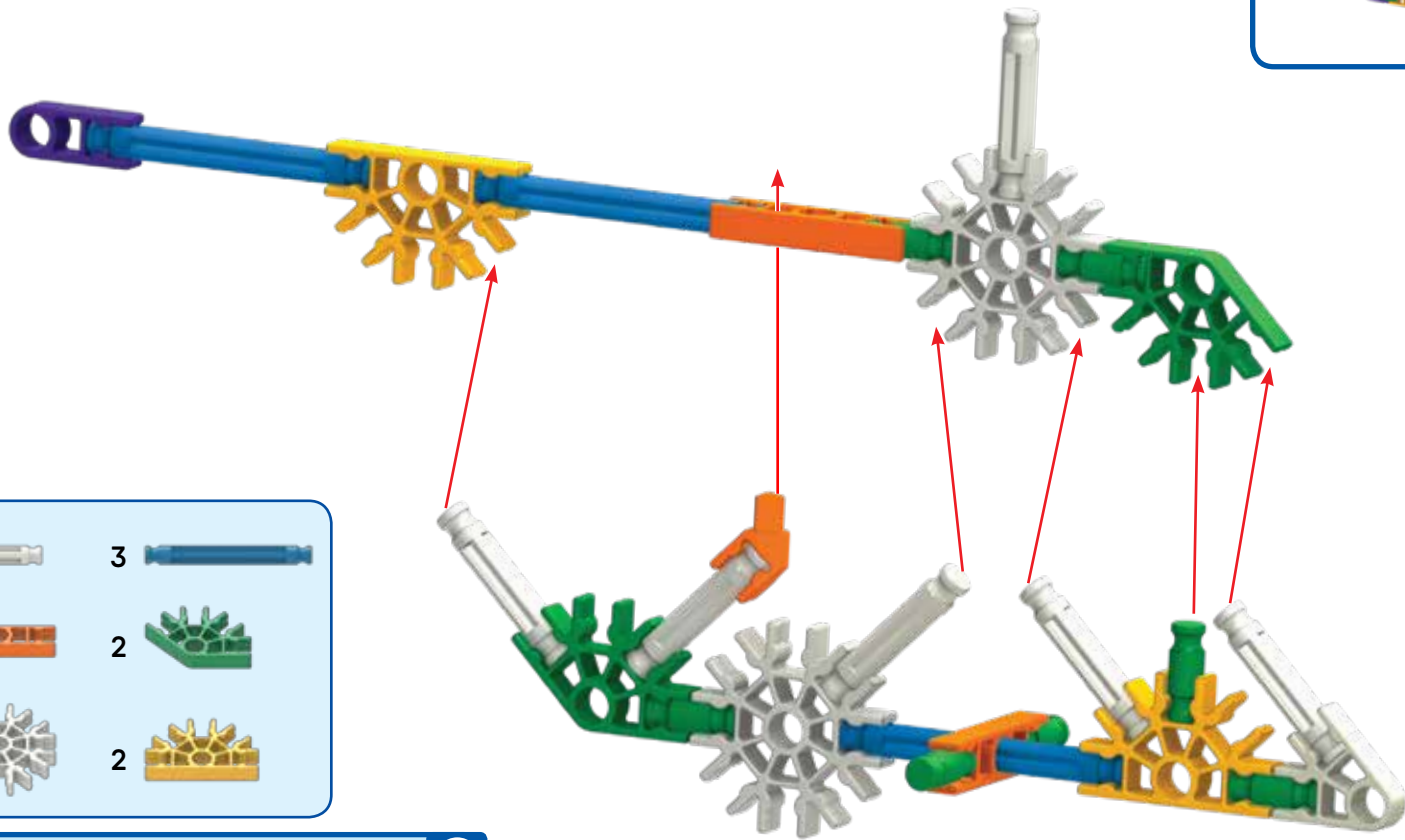

- | | | | | | |
|---|--|---|--|---|--|
| 7 | | 6 | | 3 | |
| 1 | | 2 | | 2 | |
| 1 | | | | | |
| 1 | | 2 | | 2 | |

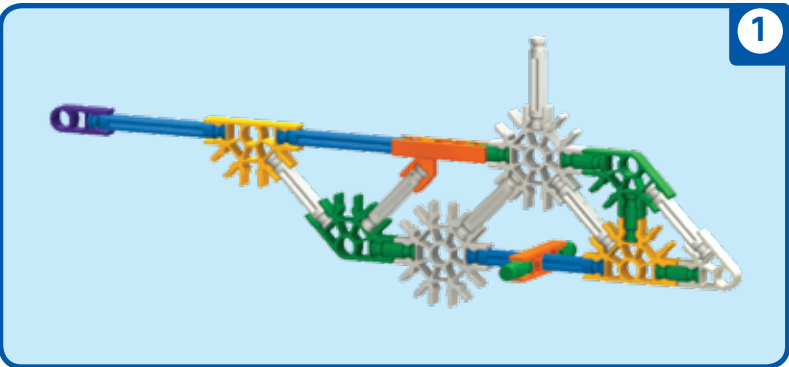

2

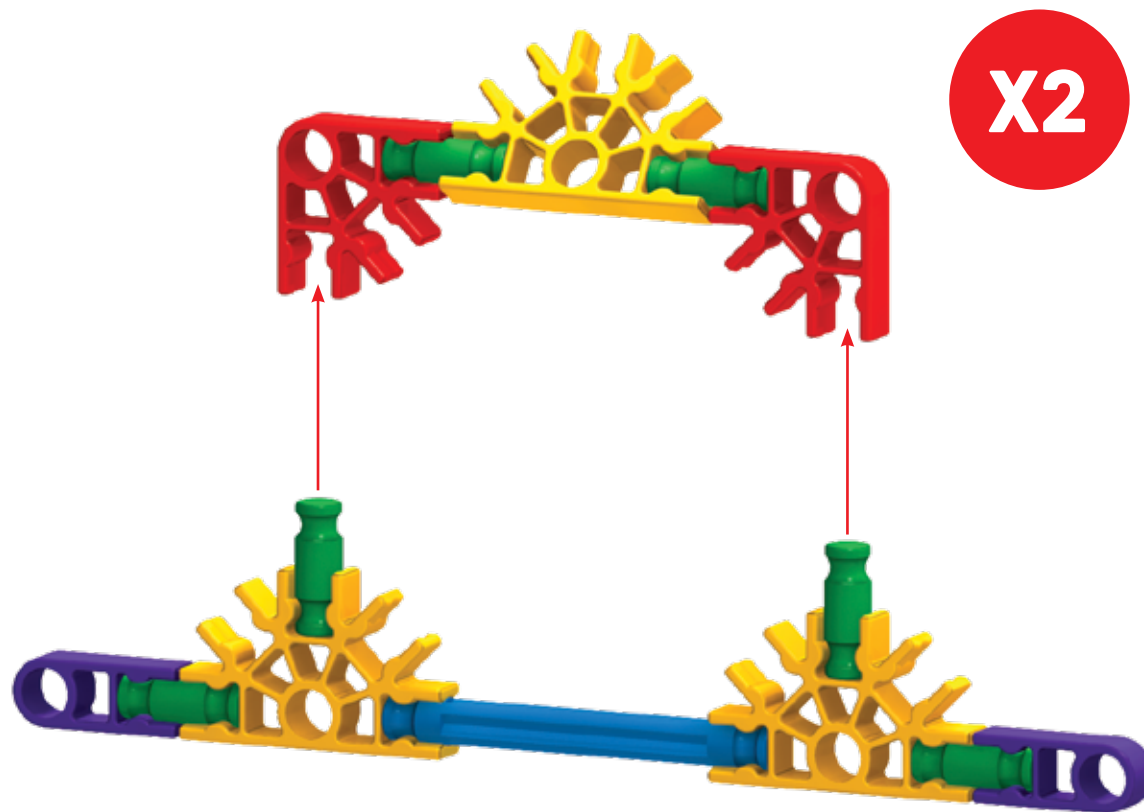

X2

X2

2

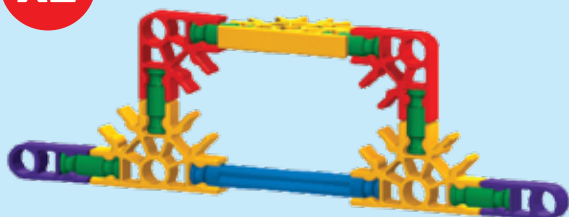

12 

2 

4 

6 

4 

3

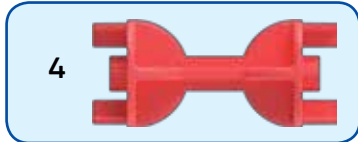
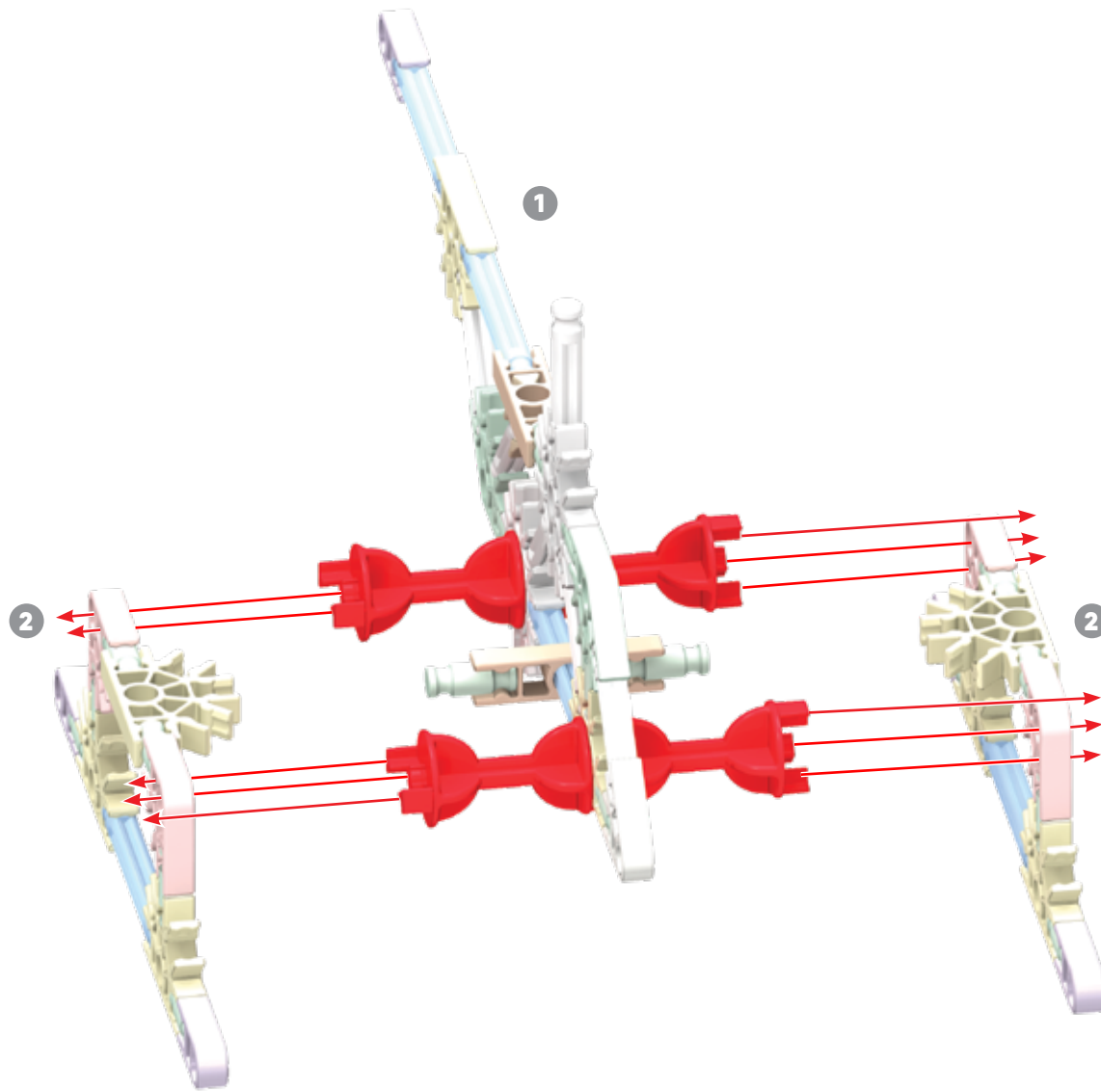

4

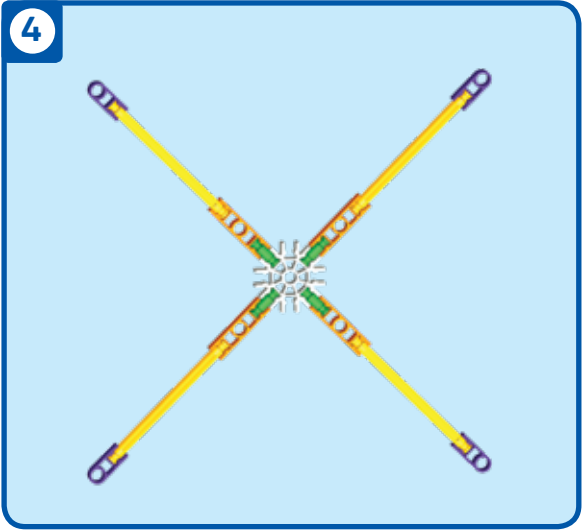
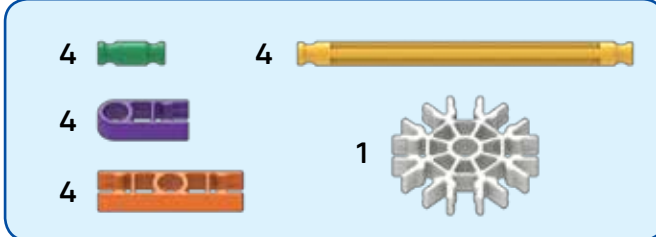
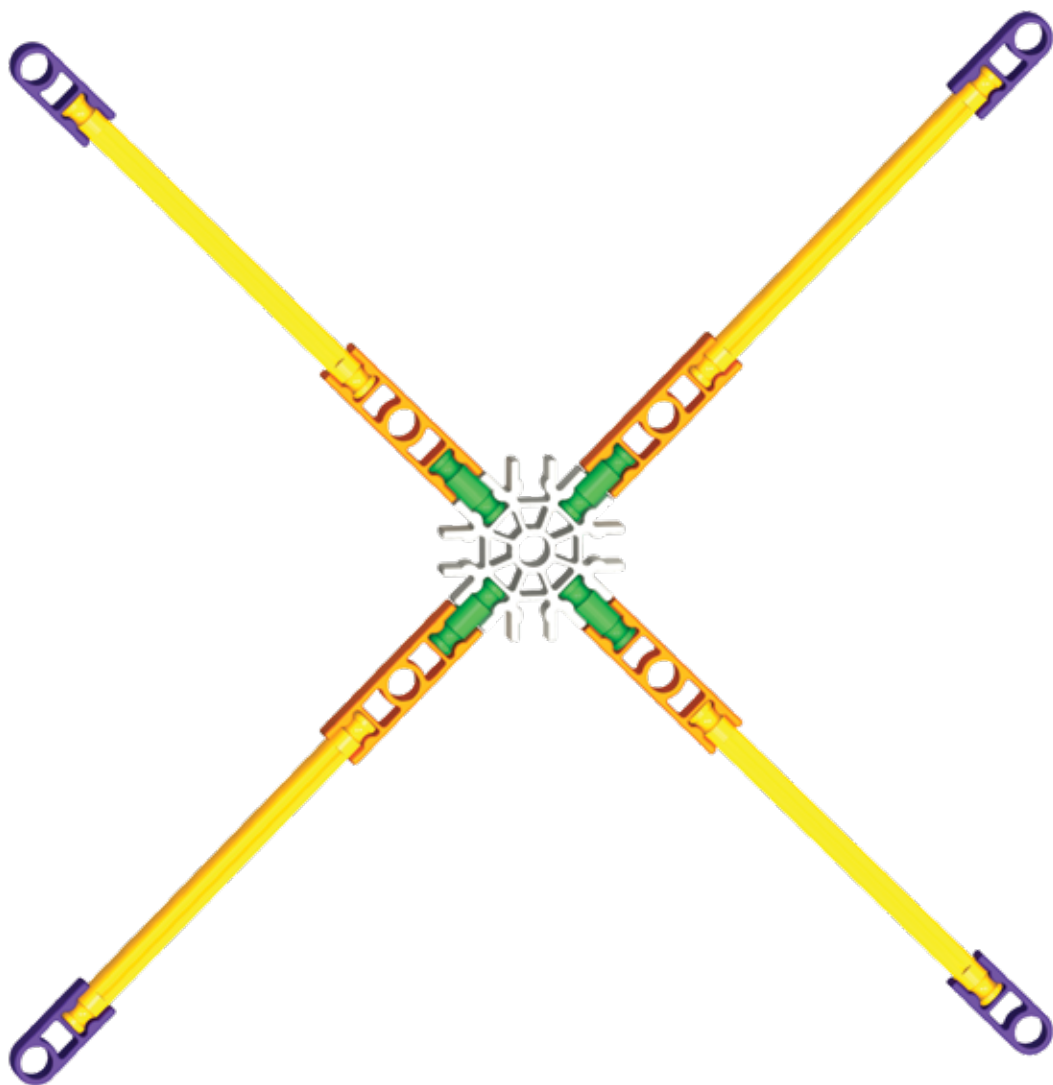

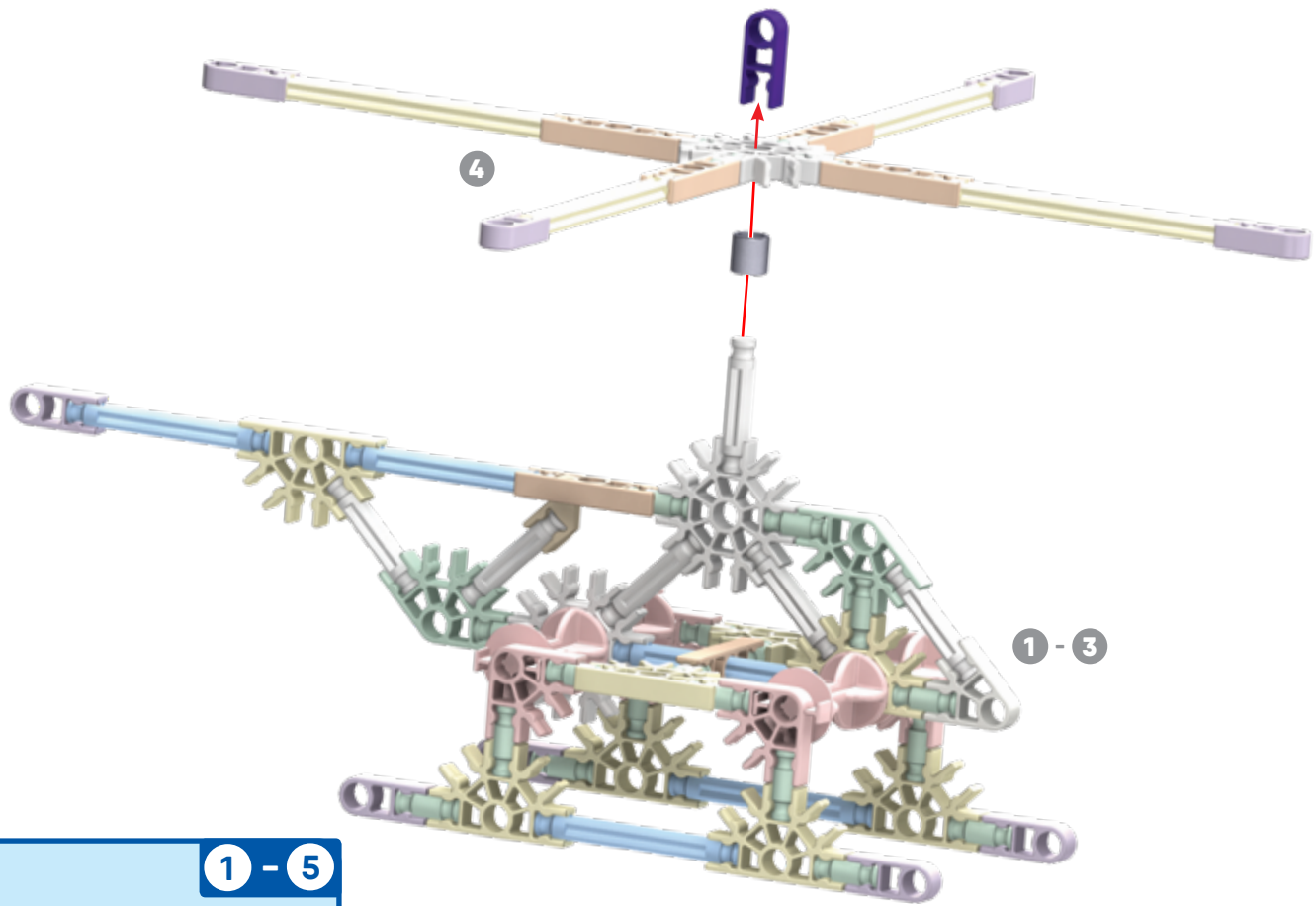

5



Helicopter

1 - 5



- 1 
- 1 

1

Balancing Act

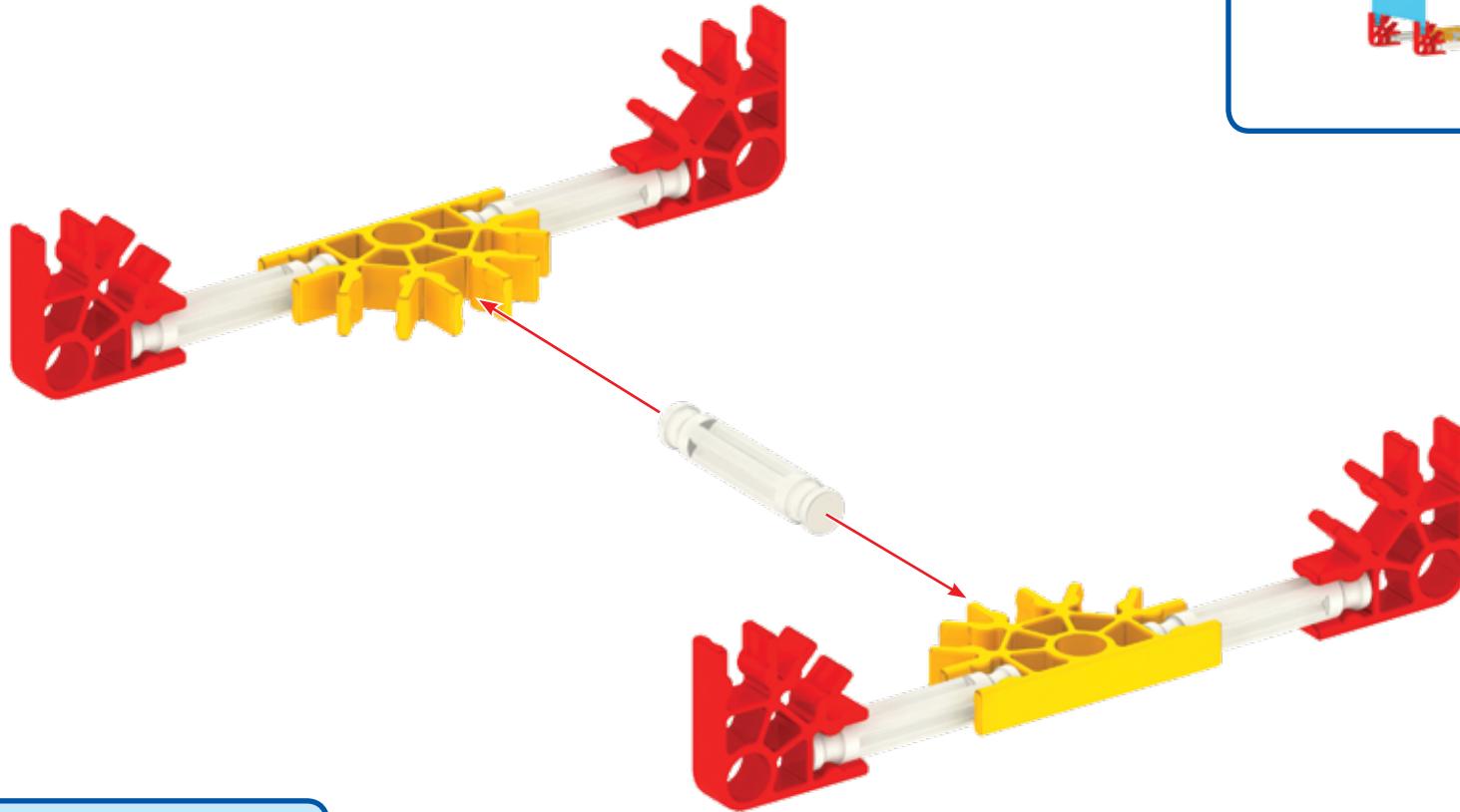
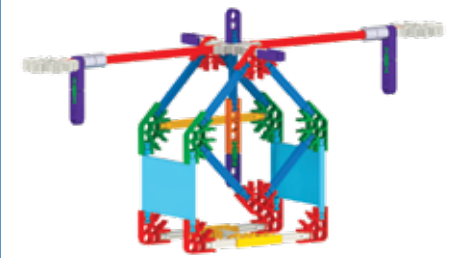

1

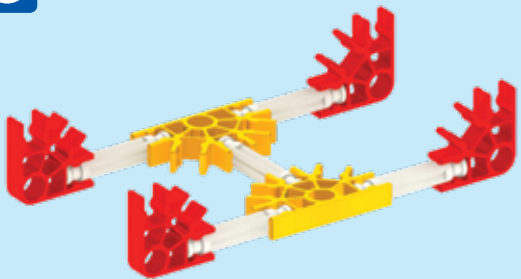

2



4

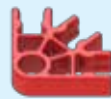

5



2

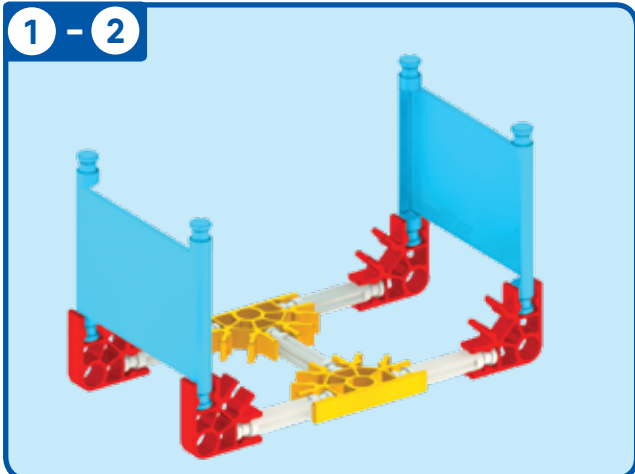
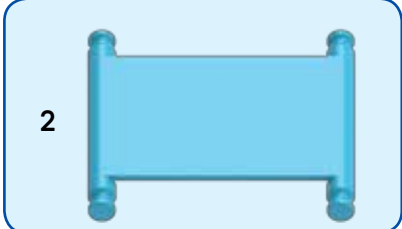
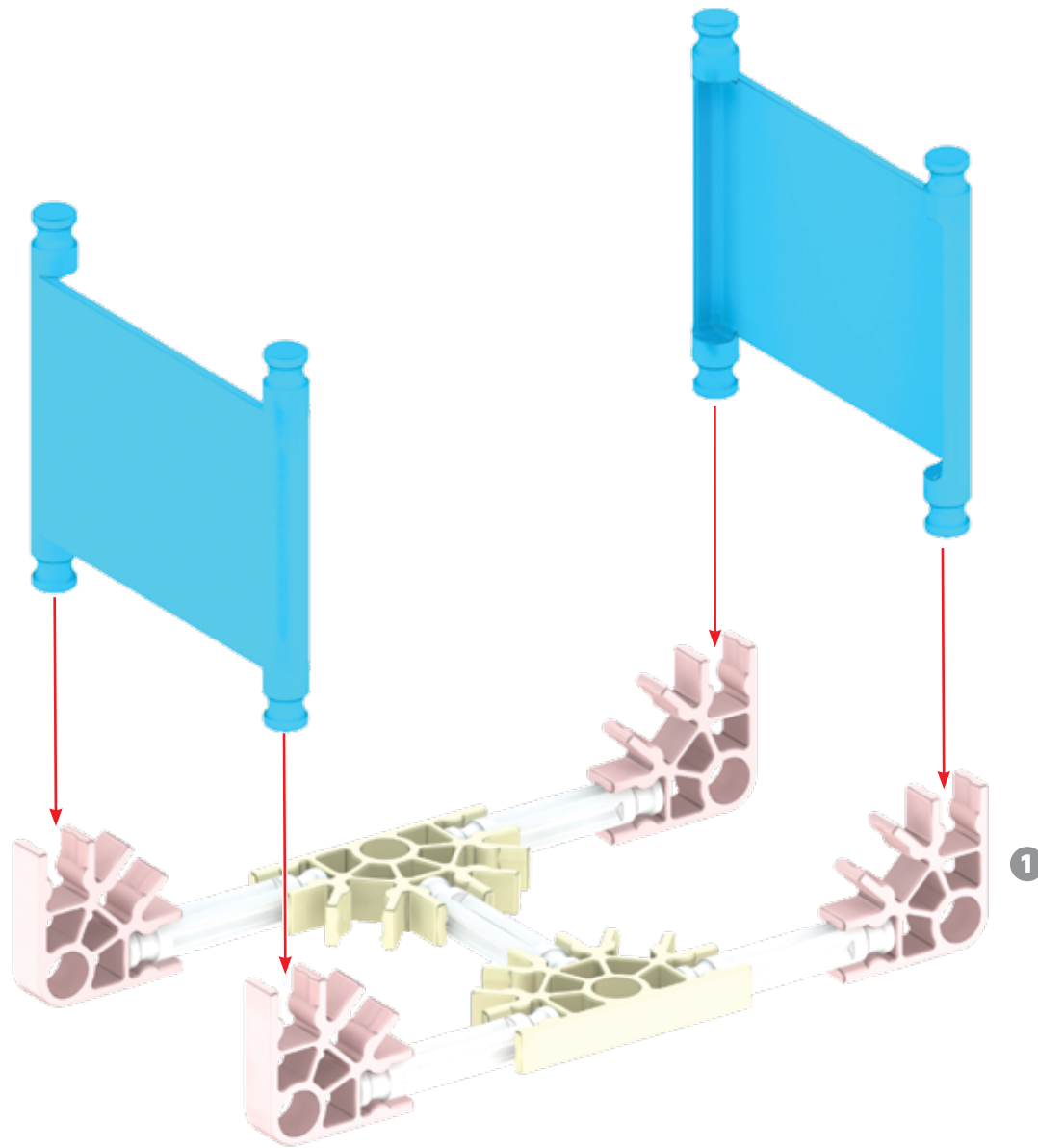

3

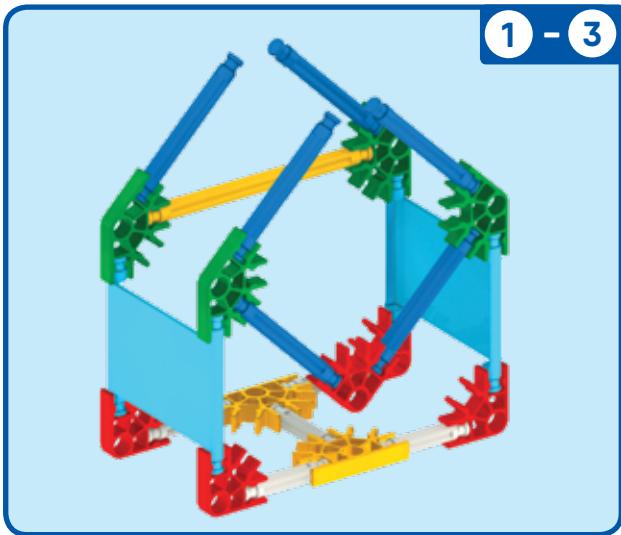
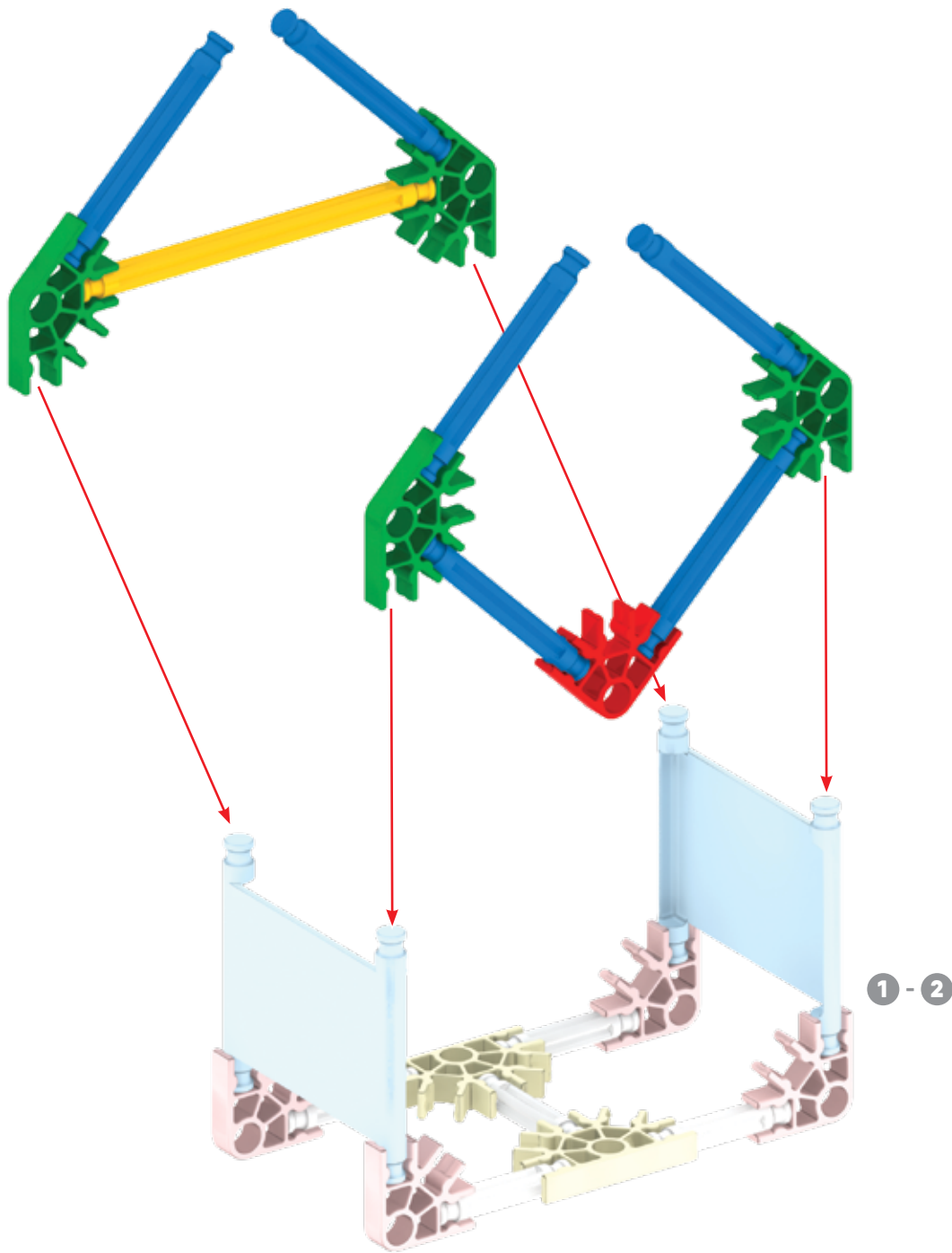



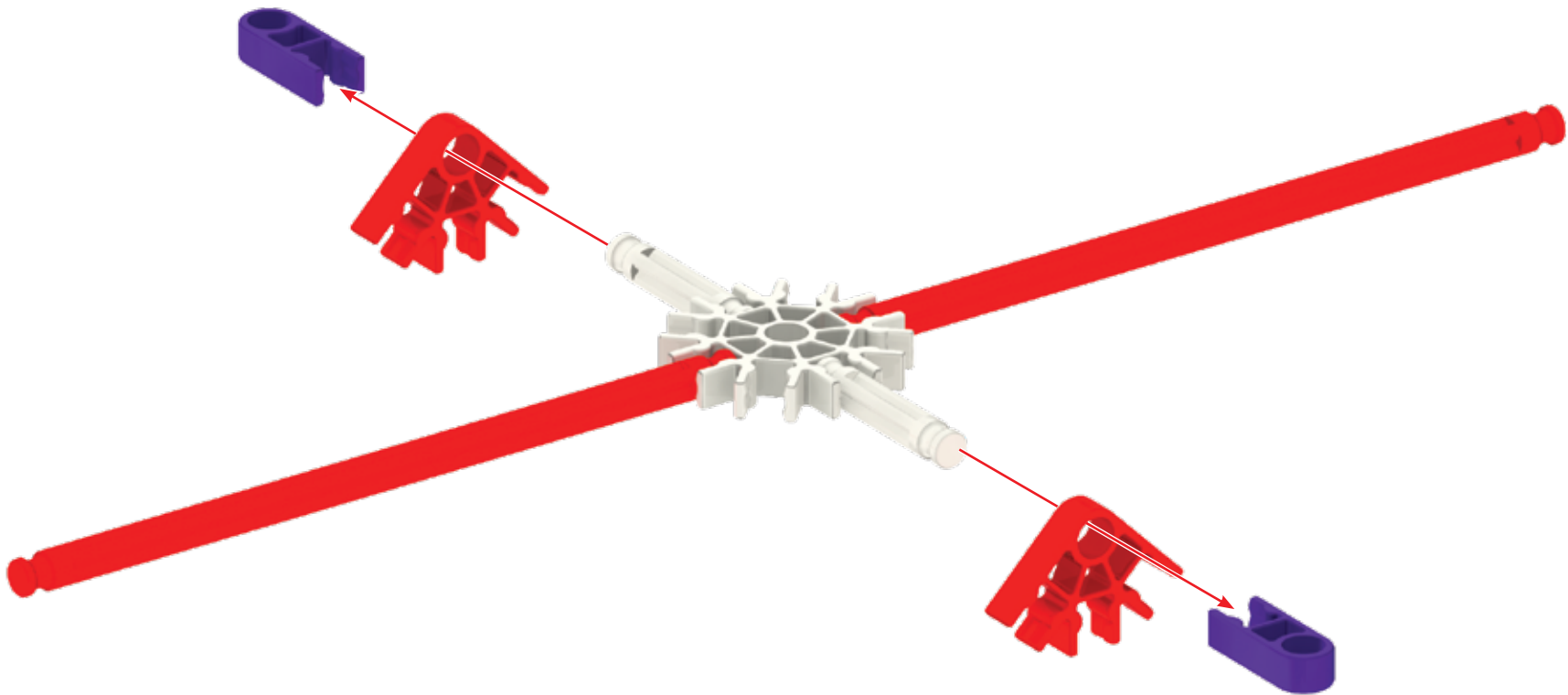

4

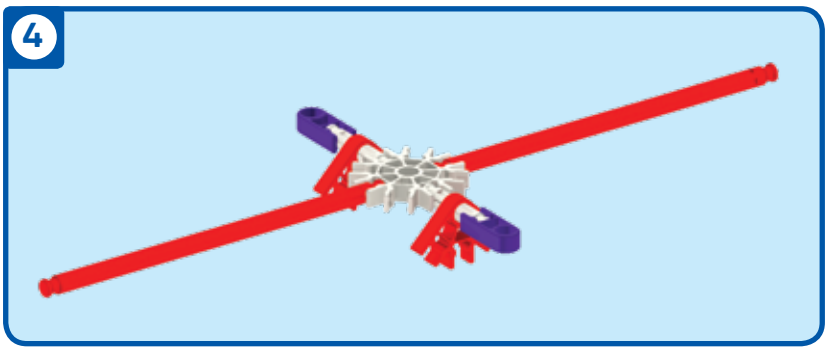

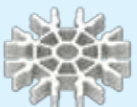
4



- 1 
- 2 
- 2 
- 2 
- 2 

5

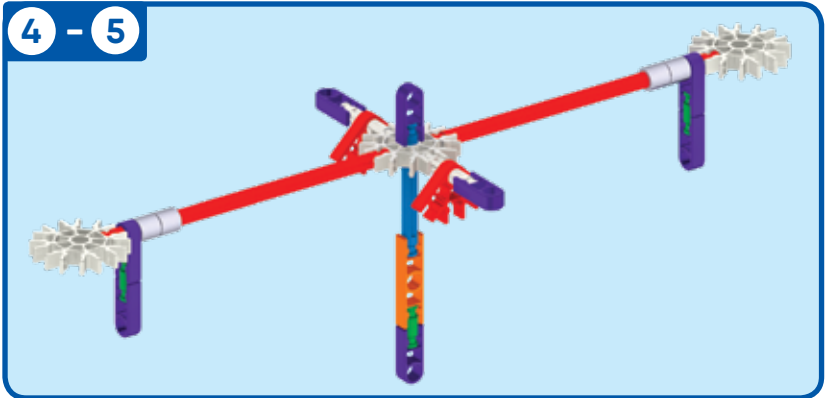
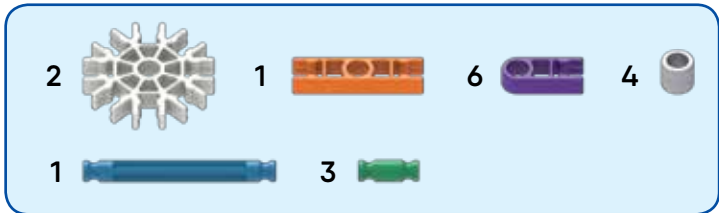
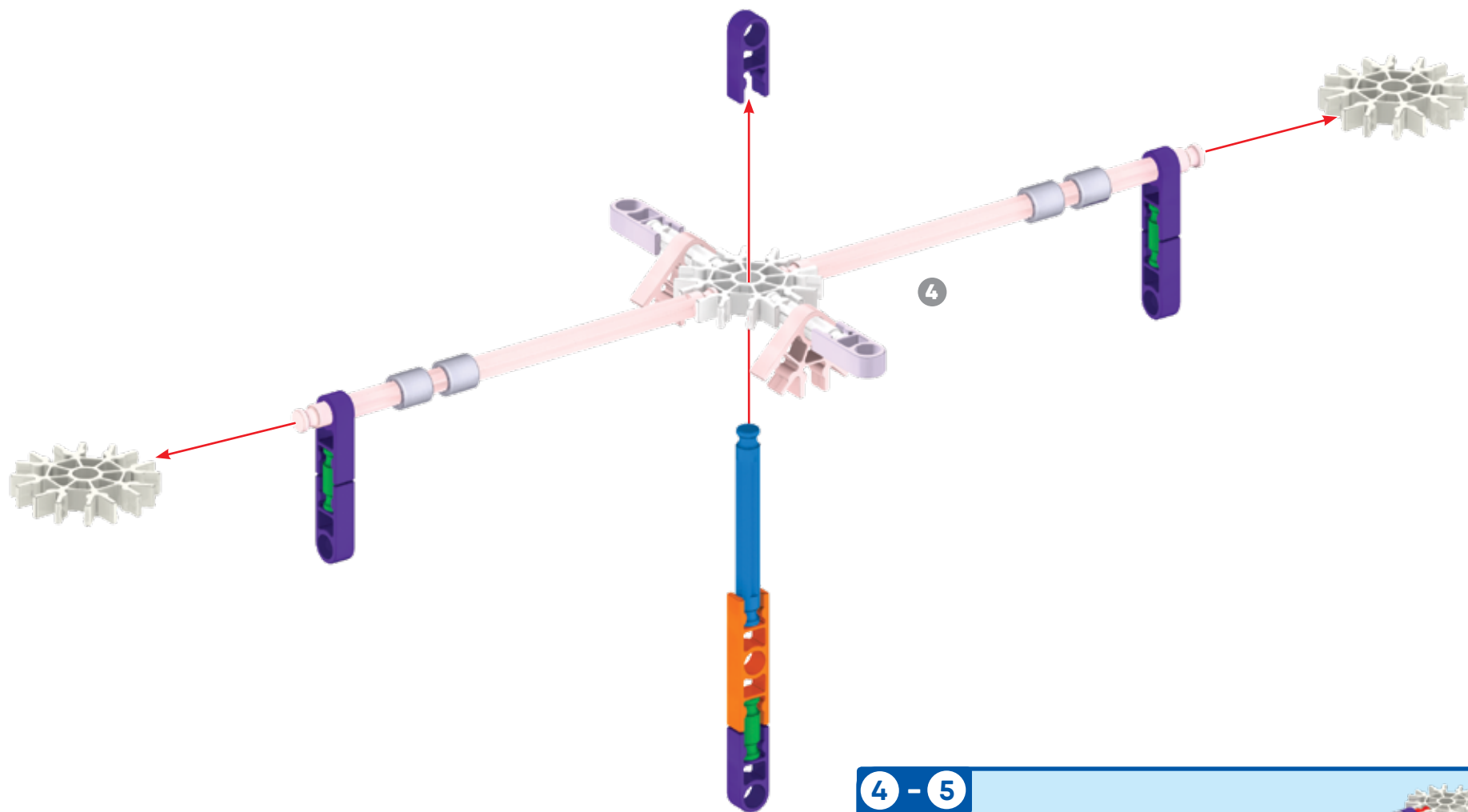

6

Balancing Act

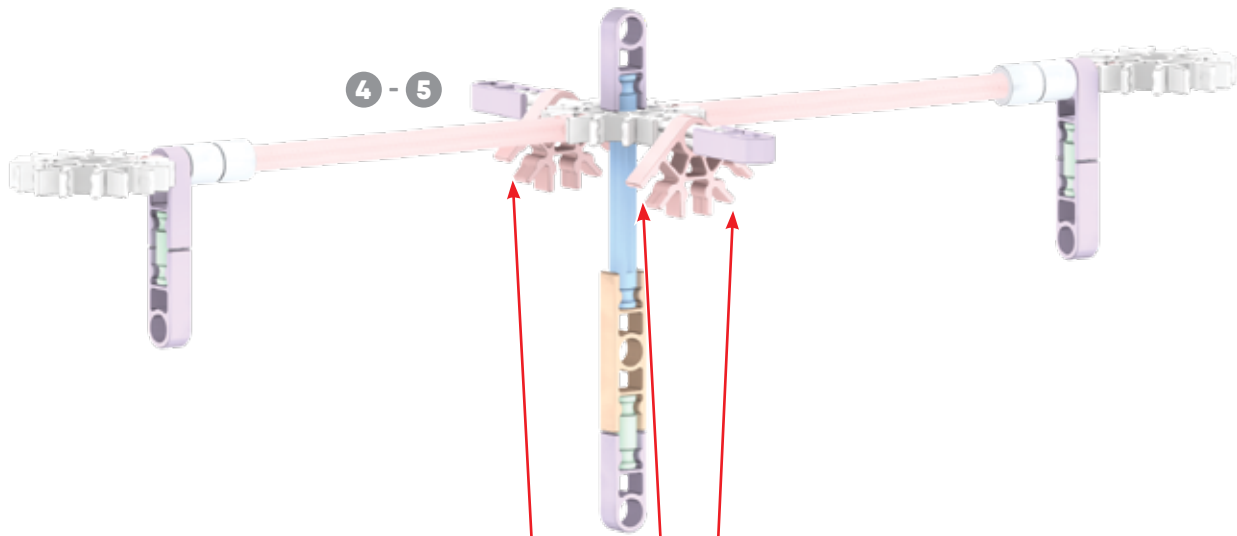

4 - 5

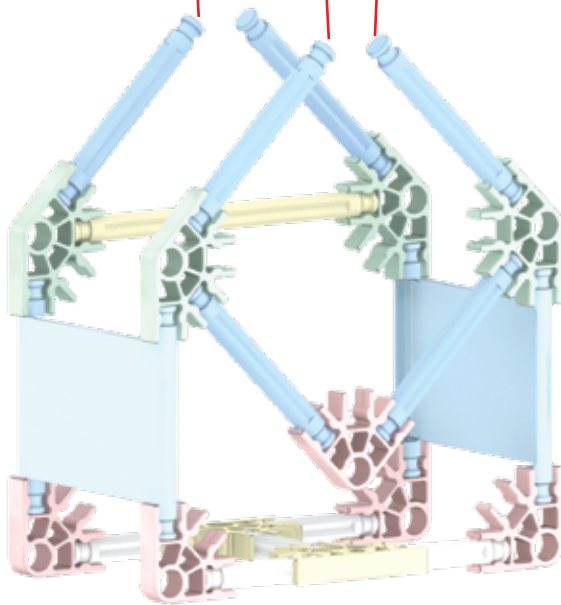

1 - 3

1 - 6

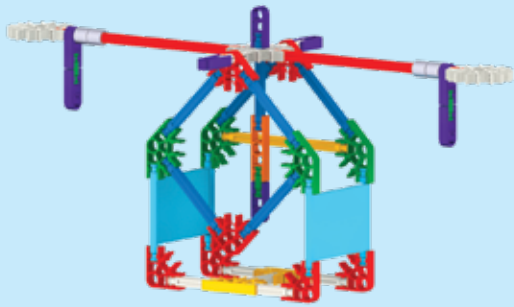

1

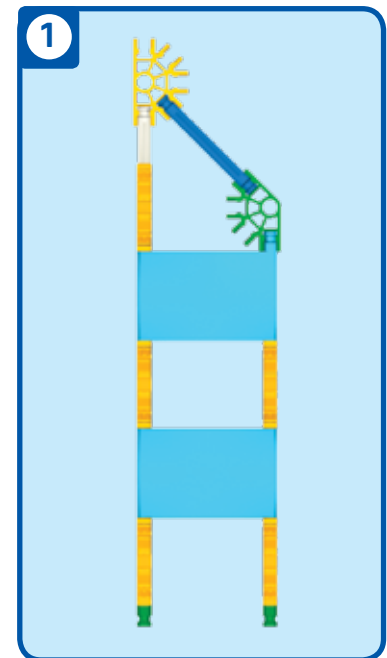
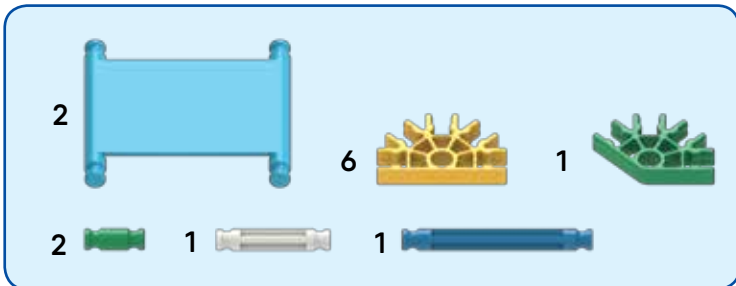
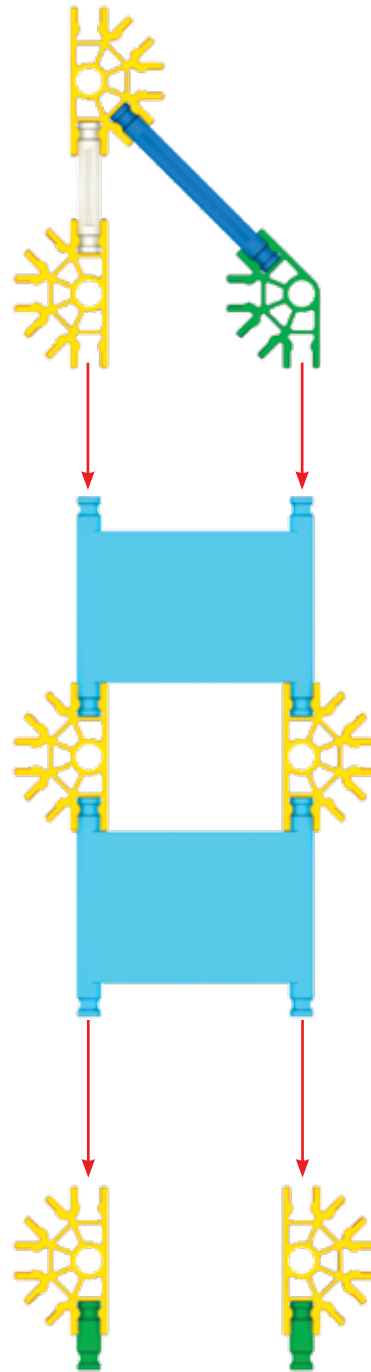

3

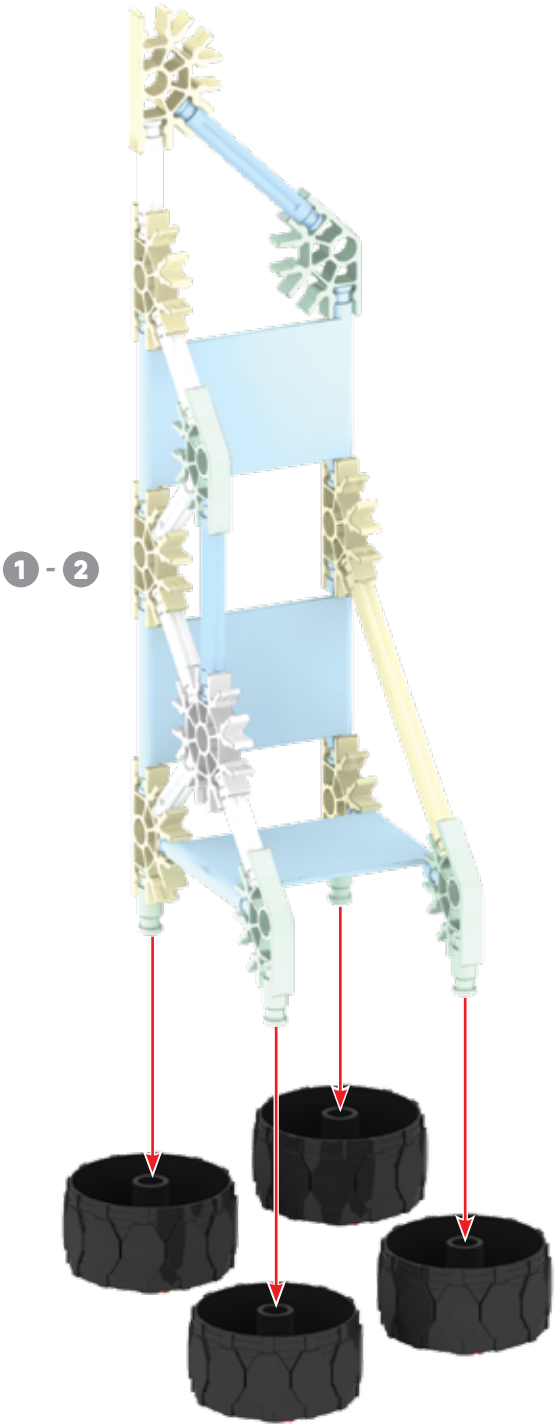

4

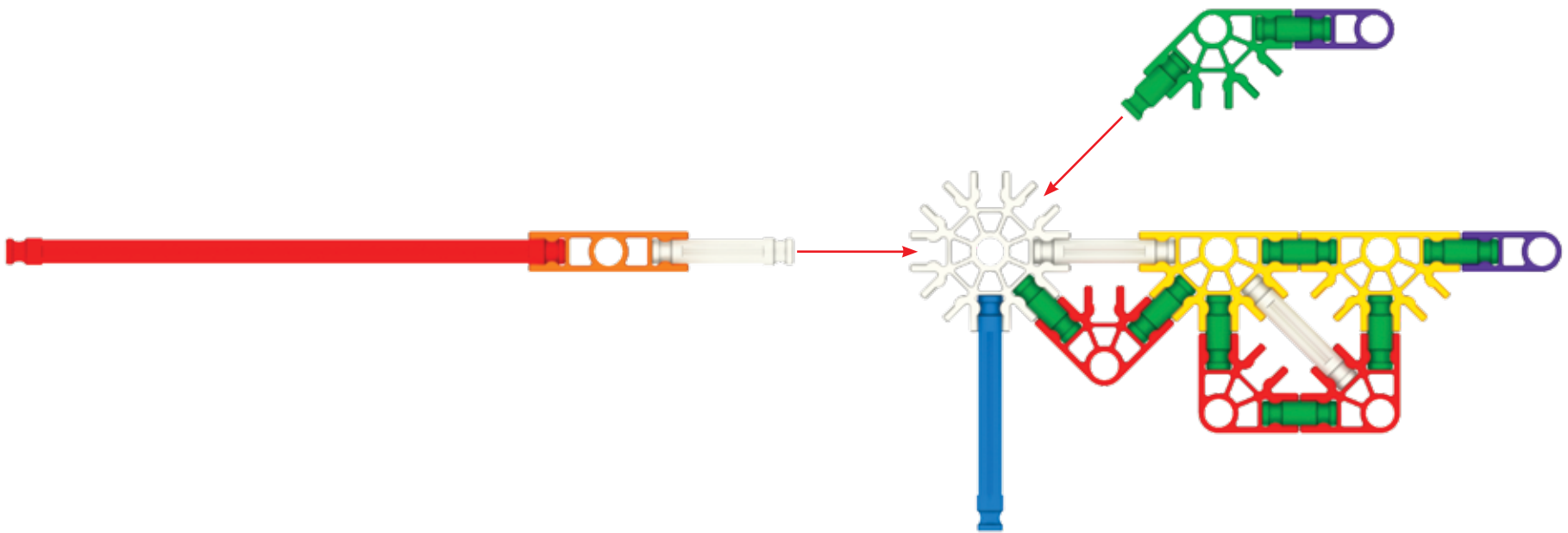

- | | | | | | | | |
|---|--|---|--|---|--|---|--|
| 1 | | 2 | | 1 | | 3 | |
| 1 | | 2 | | 9 | | 1 | |
| 1 | | 3 | | | | | |

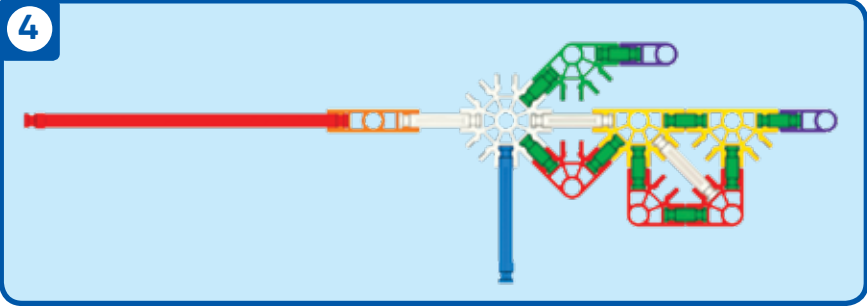

5

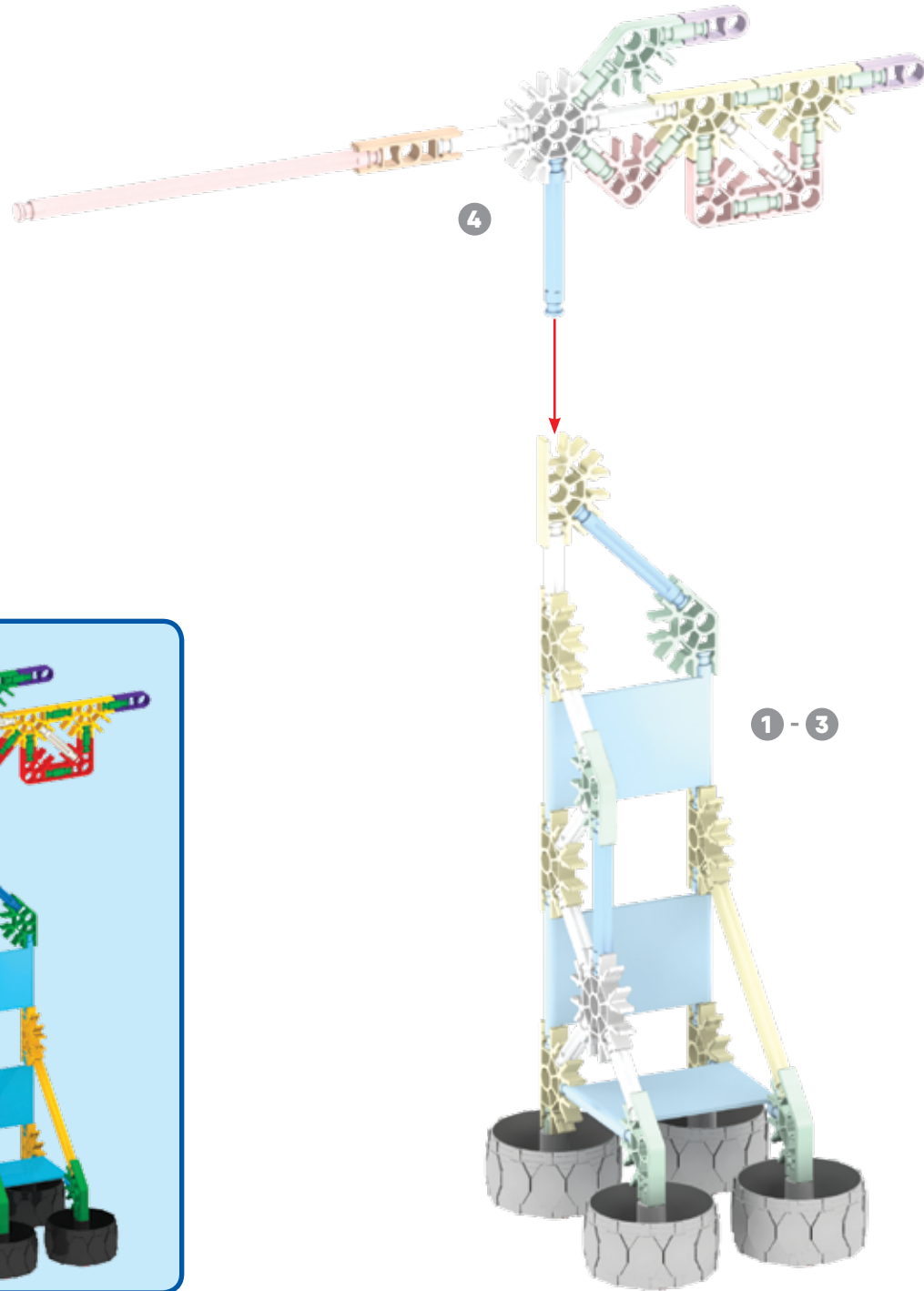

1 - 5



6

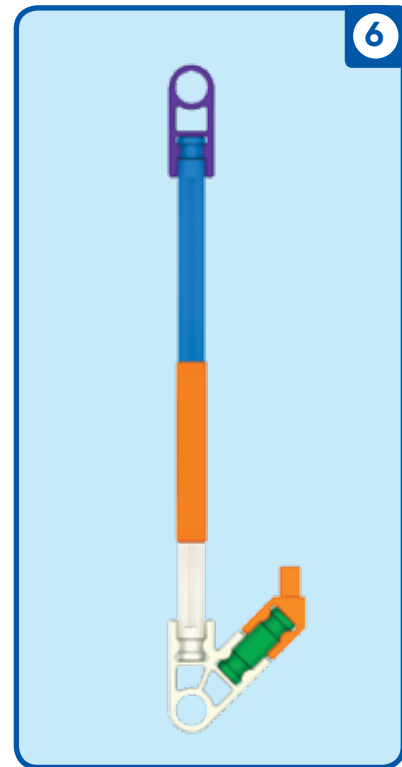
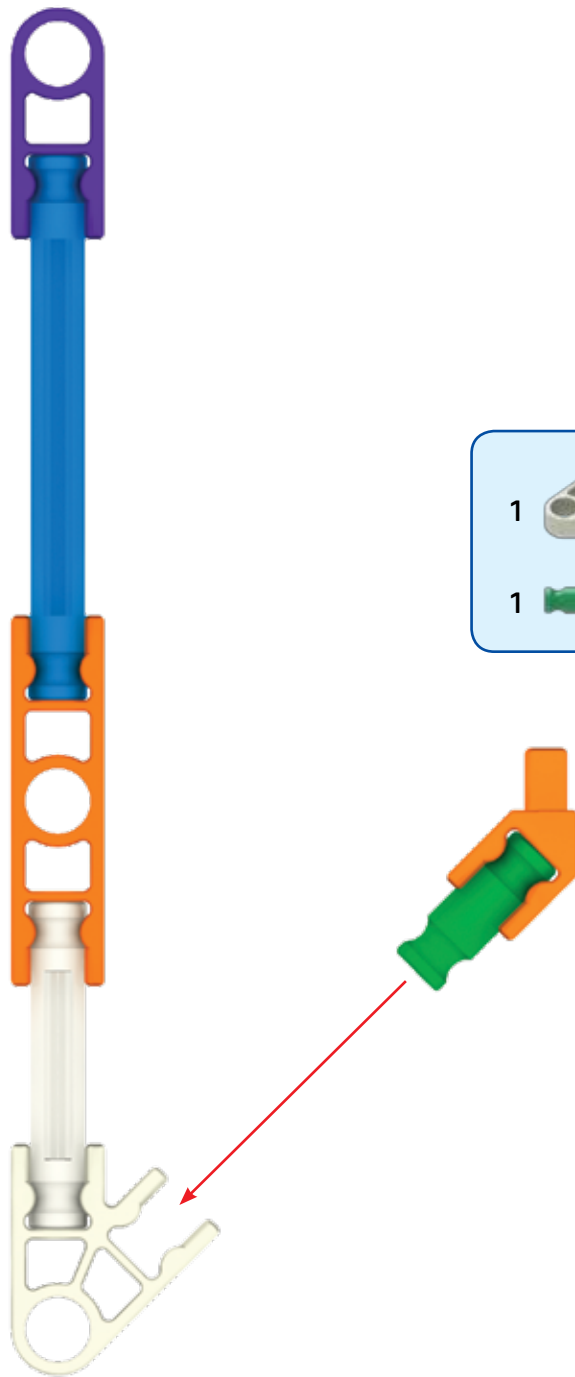

6

7

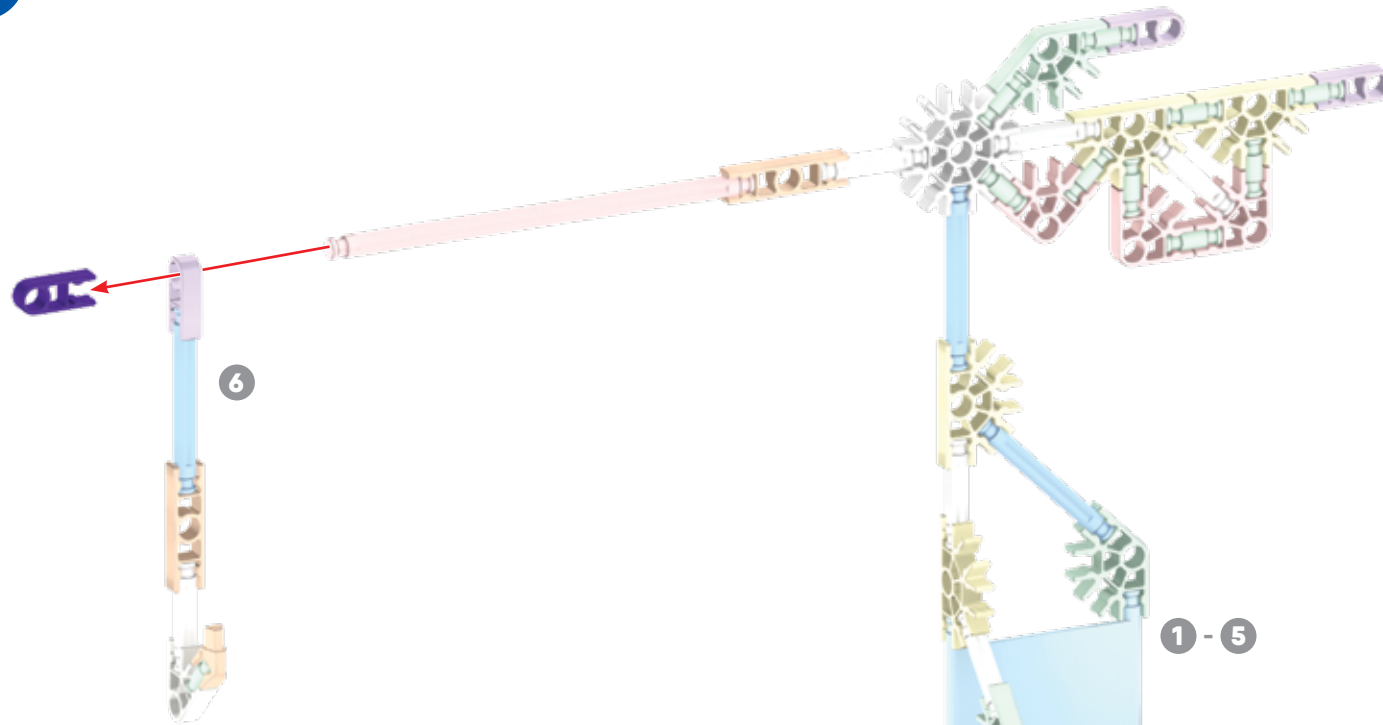

1 - 7



1

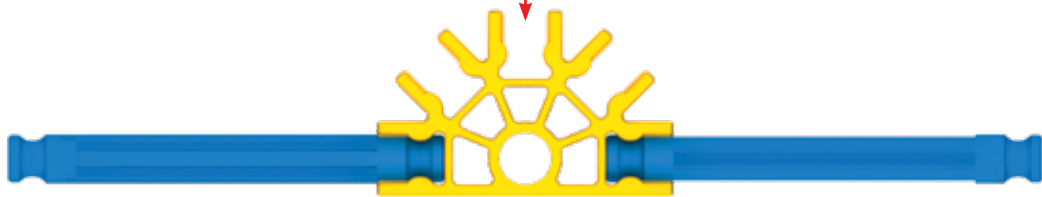
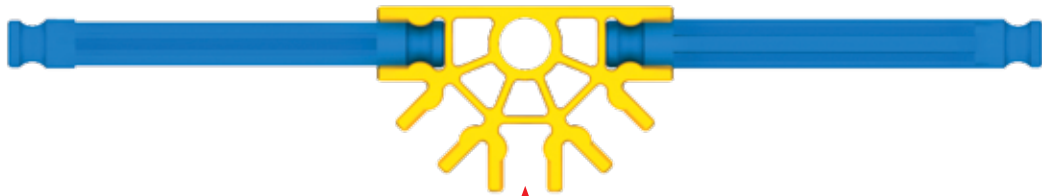

Skateboard

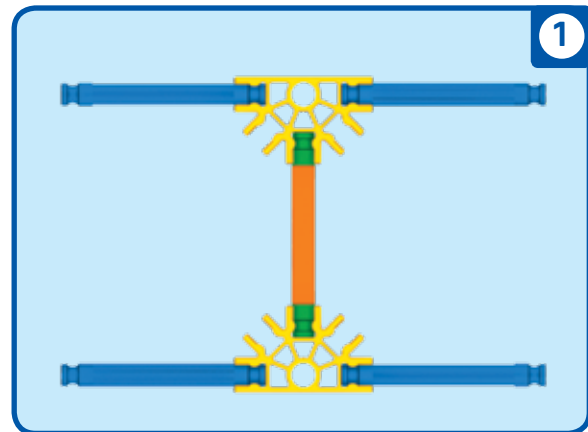
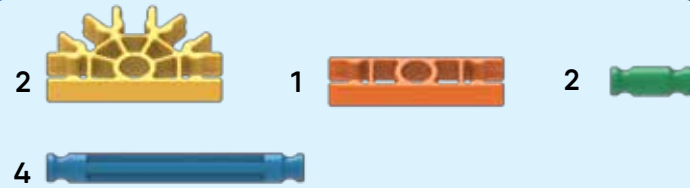

2

X2

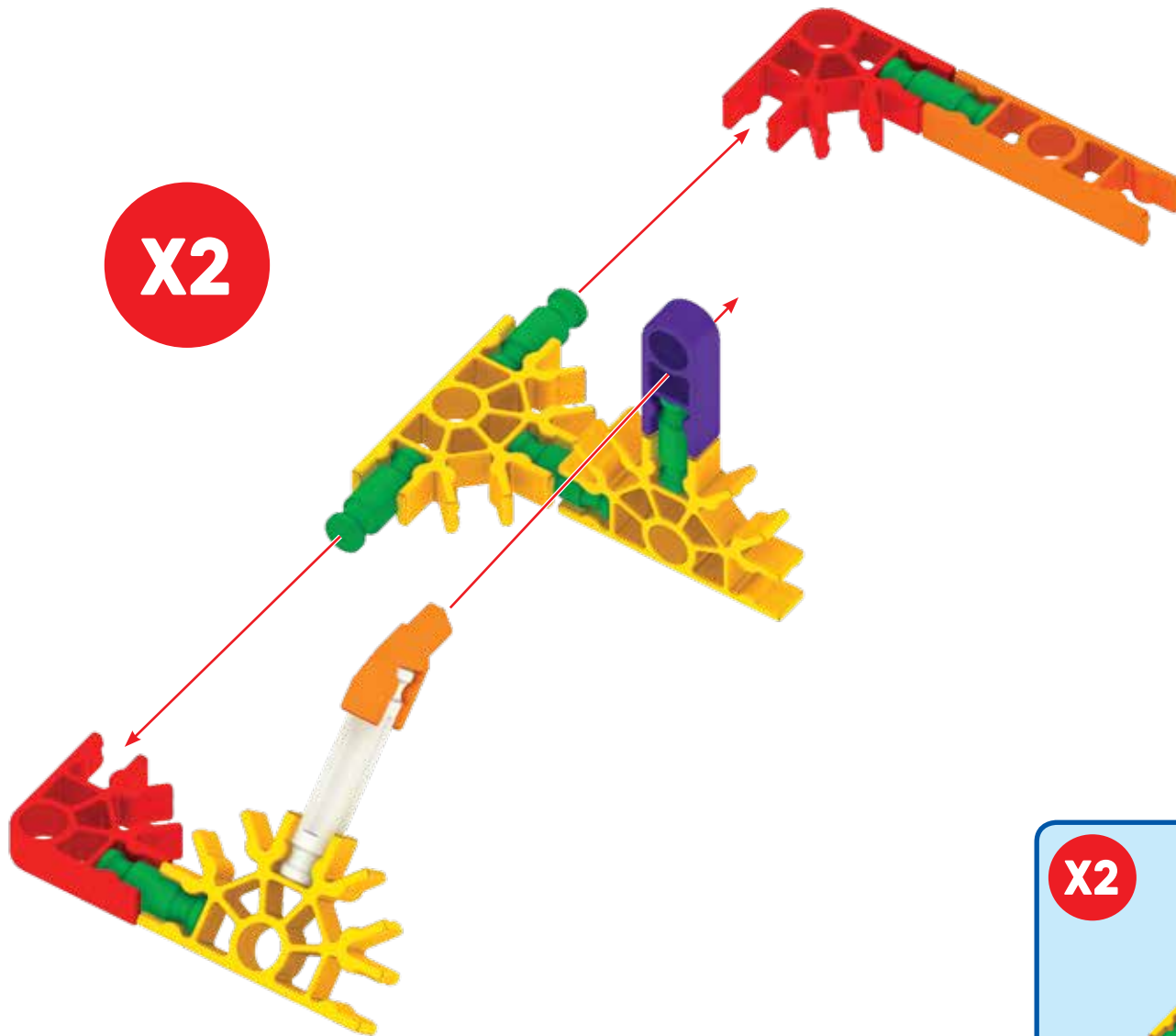

- | | | | | | | | |
|---|--|----|--|---|--|---|--|
| 6 | | 4 | | 2 | | 2 | |
| 2 | | 12 | | 2 | | | |

X2

2

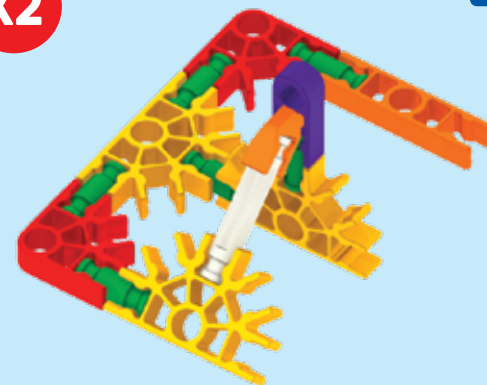

3

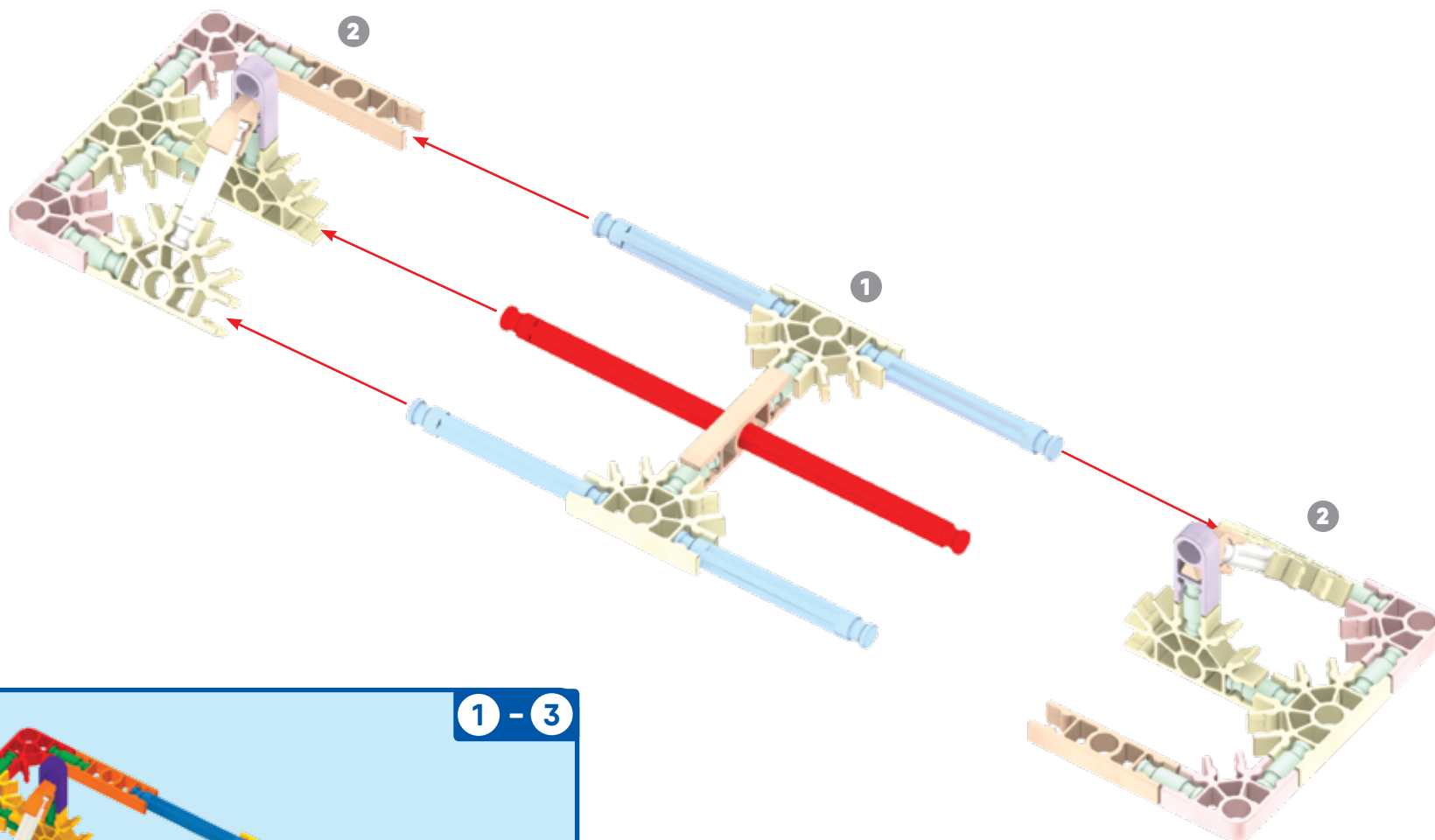

1 - 3

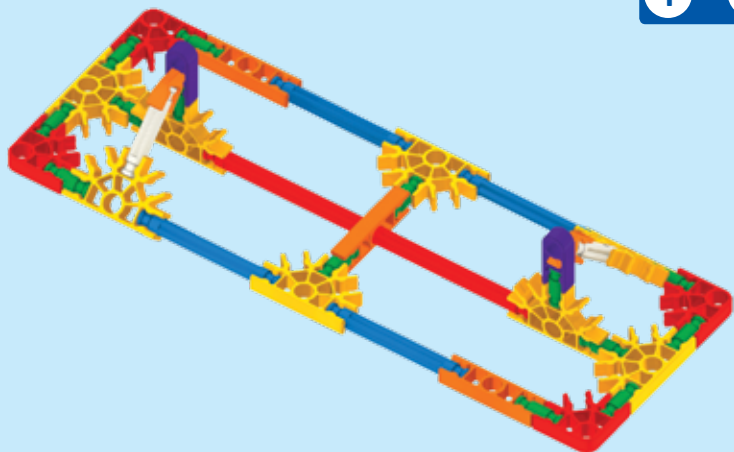

1



4

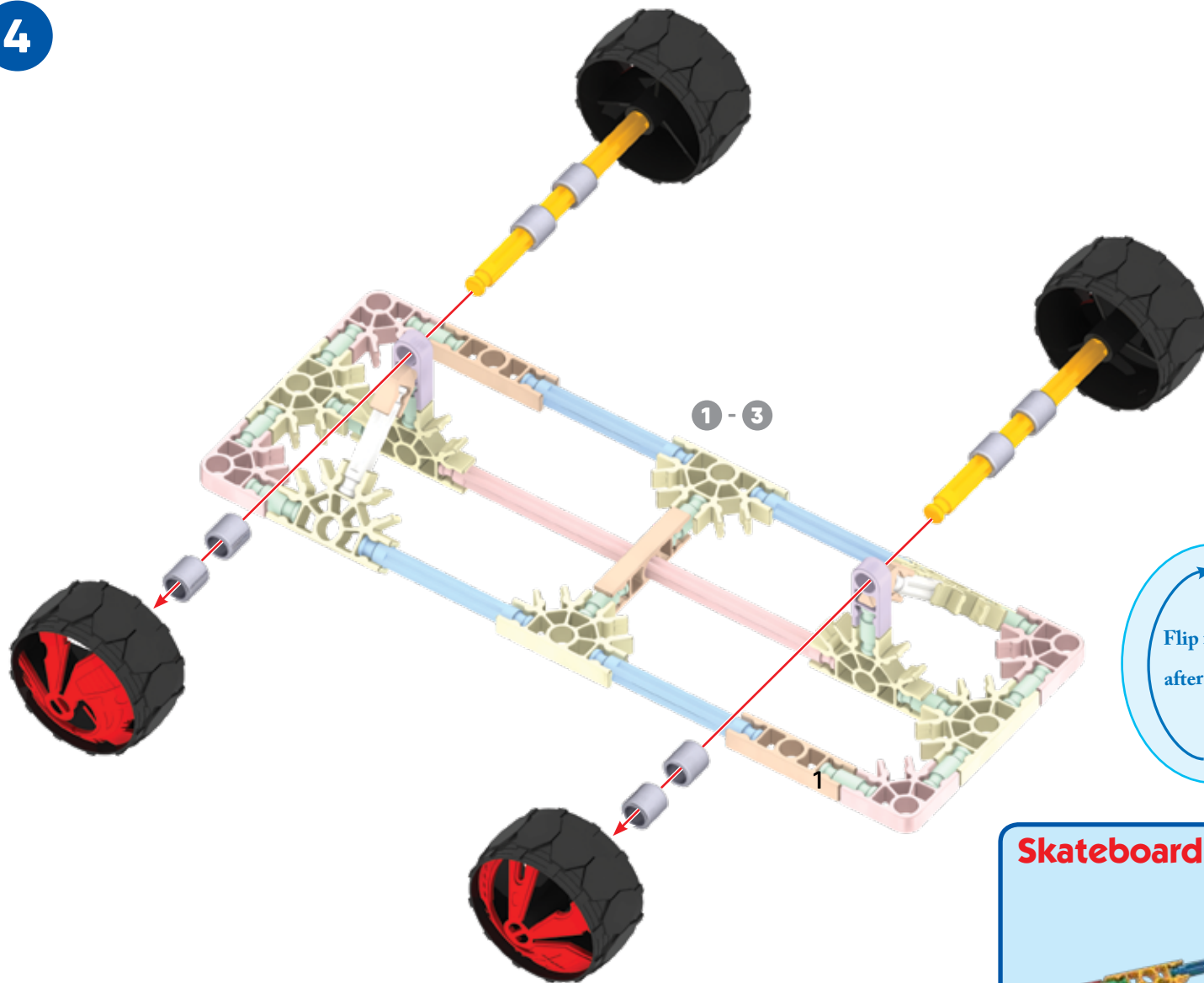

Flip model
after step 4

